

JUNGLE GYM

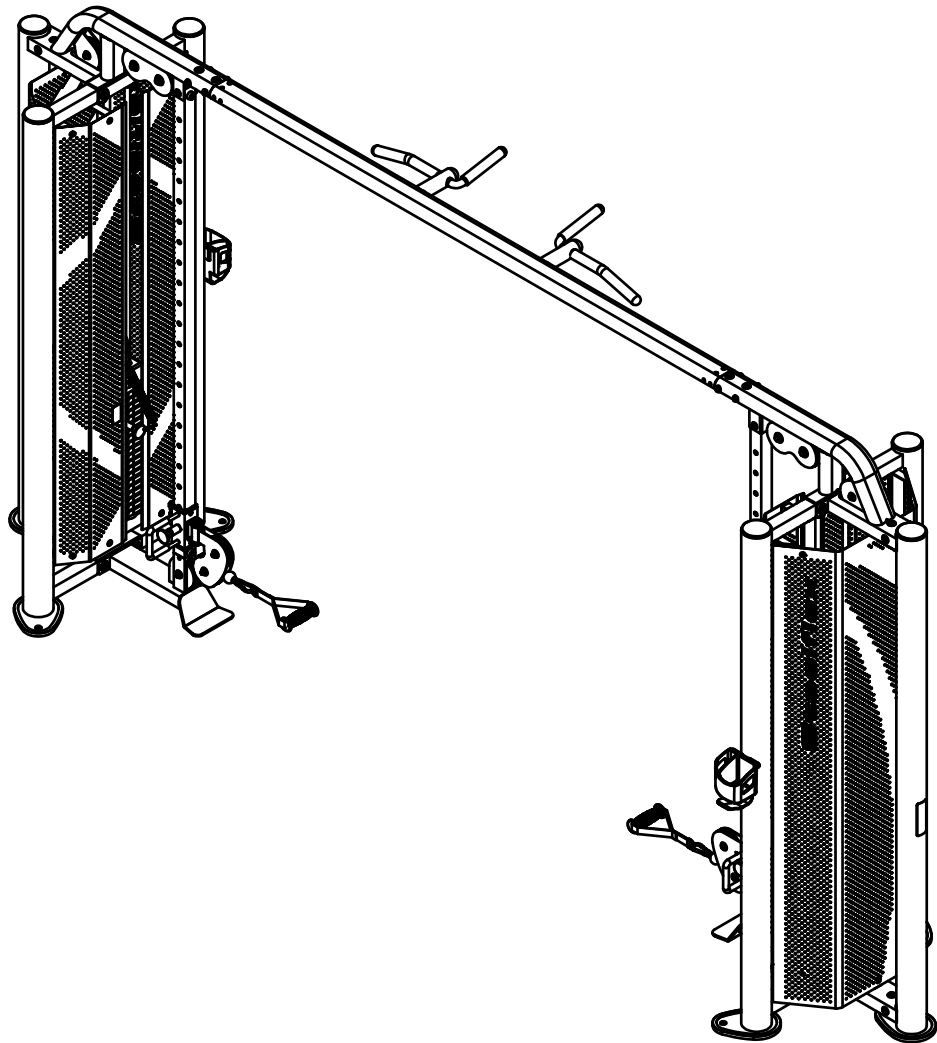

JOONG CHENN INDUSTRY CO., LTD.

Sales Office:

3F28, No.5, Shin-Yi Rd., Sec. 5, Taipei, Taiwan 110 R.O.C.

Tel: 886-2-27209980



Fax: 886-2-27229750

www.steelflexfitness.com

JG2000 OWNER'S MANUAL

JUNGLE GYM ASSEMBLY INSTRUCTIONS

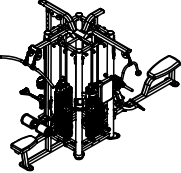
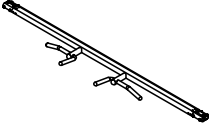
JUNGLE GYM SERIES CONFIGURATION FORM

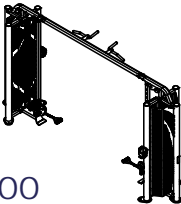
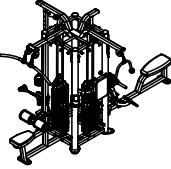
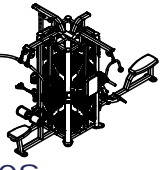
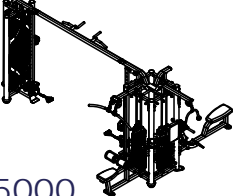
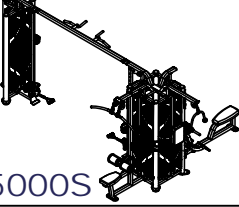
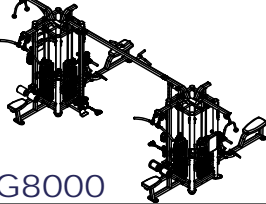
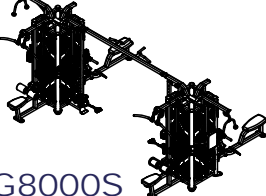
	JG1000	JG4000	JG	JGC
				
 JG2000	X2		○	
 JG4000		○		
 JG4000S		○		○
 JG5000	○	○	○	
 JG5000S	○	○	○	○
 JG8000		X2	○	
 JG8000S		X2	○	X2

JUNGLE GYM

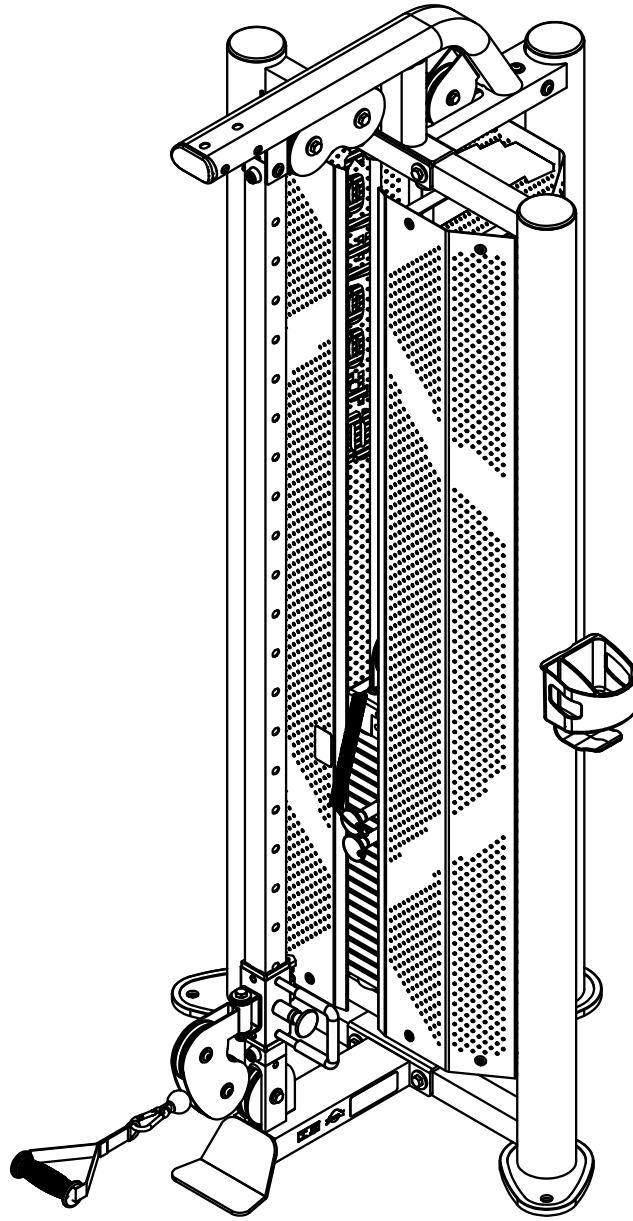

JOONG CHENN INDUSTRY CO., LTD.

Sales Office:

3F28, No.5, Shin-Yi Rd., Sec. 5, Taipei, Taiwan 110 R.O.C.

Tel: 886-2-27209980

Fax: 886-2-27229750

www.steelflexfitness.com

JG1000 OWNER'S MANUAL

JG1000 ASSEMBLY INSTRUCTIONS

HARDWARE ILLUSTRATION

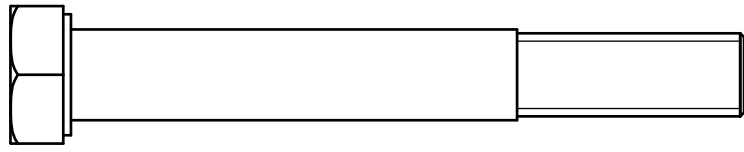
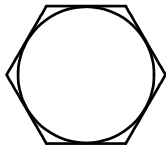

(A1)ROUND INNER HEX SCREW M12X90L PARTIAL THREAD QTY.1

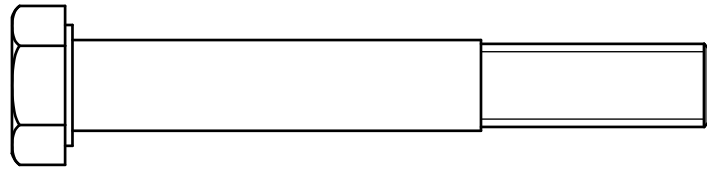
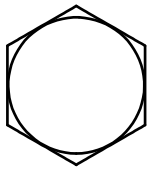

(A2)HEX BOLT M12X85L PARTIAL THREAD QTY.4

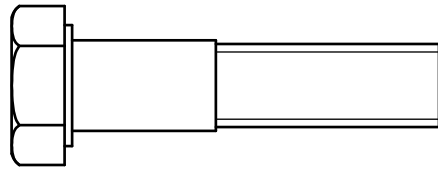
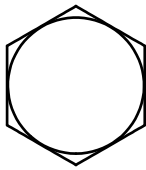

(A3)HEX BOLT M12X50L PARTIAL THREAD QTY.2

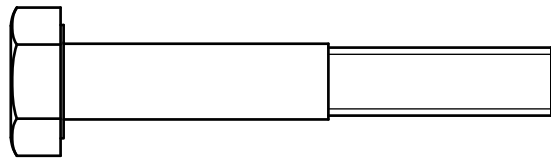
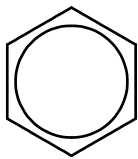

(A4)HEX BOLT M10X65L PARTIAL THREAD QTY.1

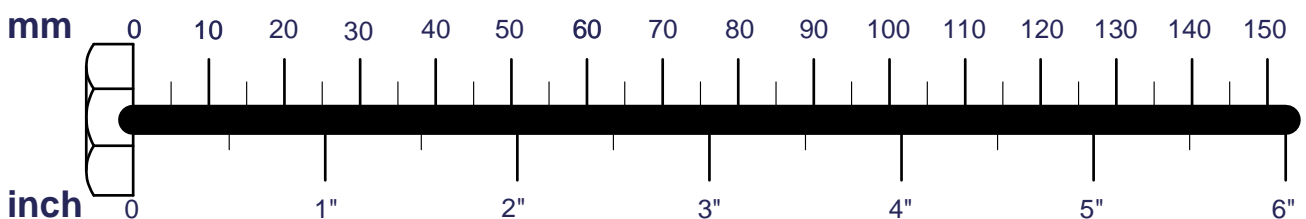

JG1000 ASSEMBLY INSTRUCTIONS

HARDWARE ILLUSTRATION

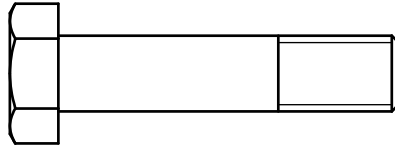
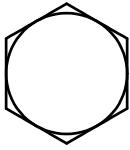

(A5)HEX BOLT M10X45L PARTIAL THREAD QTY.3

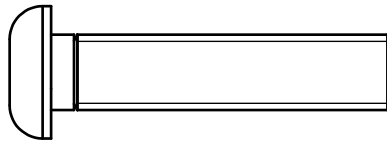
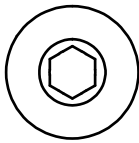

(A6)ROUND INNER HEX SCREW M10X45L PARTIAL THREAD QTY.2

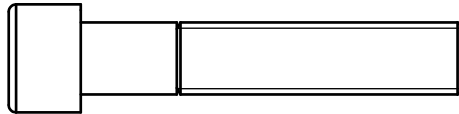
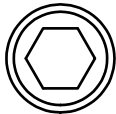

(A7) ROUND ALLEN HEAD 3/8"x2"L PARTIAL QTY.1

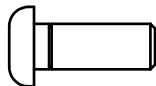

(A8)ROUND INNER HEX SCREW M6X16L PARTIAL THREAD QTY.16

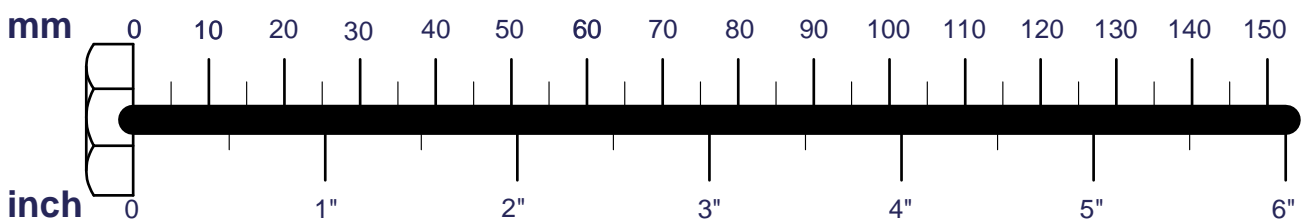

JG1000 ASSEMBLY INSTRUCTIONS

HARDWARE ILLUSTRATION

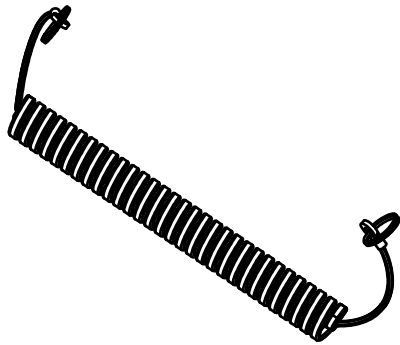

(A9)ELASTIC BELT QTY.1

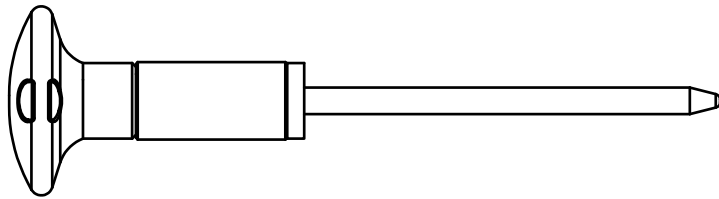

(A10)20LB PIN(8250-162) QTY.1



(A11) ROUND ALLEN HEAD M8X15L PARTIAL QTY.1

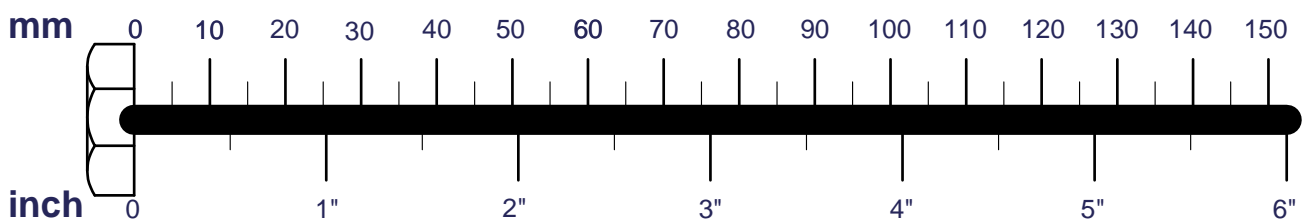

JG1000 ASSEMBLY INSTRUCTIONS

HARDWARE ILLUSTRATION

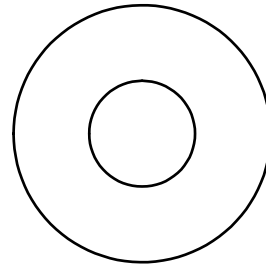
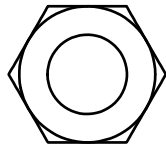

(B1) NYLON LOCK NUT M12 QTY.7

(C1) M12(I.D.) FLAT WASHER Ø34 QTY.14

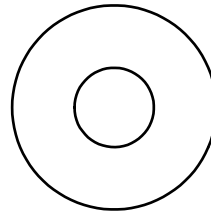
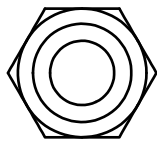

(B2) NYLON LOCK NUT M10 QTY.6

(C2) M10(I.D.) FLAT WASHER Ø27 QTY.12

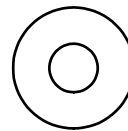
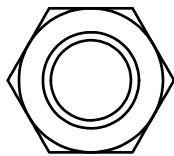

(B3) 1/2" NUT-13UNC QTY.2

(C3) M6(I.D.) FLAT WASHER Ø19 QTY.16

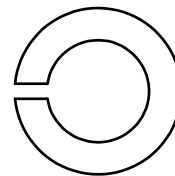

(C4) SPRING WASHER 1/2" QTY.2

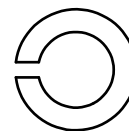

(C5) SPRING WASHER 3/8" QTY.1

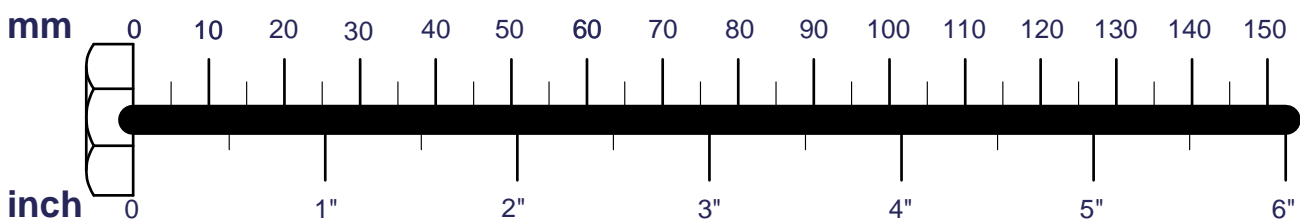

JG1000 ASSEMBLY INSTRUCTIONS

HARDWARE ILLUSTRATION

D1.HOOK(8810-001)-----	[1PCS]
D2.□60X50 NYLON BUSHING(9211-033)-----	[2PCS]
D3.3/4" SHAFT COLLAR(9211-046)-----	[2PCS]
D4.50X100X2.0tX30H END CAP(9211-114)-----	[1PCS]
D5.Ø100X30H CAP COVER(9211-186)-----	[3PCS]
D6.BOTTLE RACK(9260-320)-----	[1PCS]
D7.RUBBER DOUNT(9310-027)-----	[2PCS]
D8.226X13.5tX161 RUBBER PAD(9310-115)-----	[3PCS]
D9.NYLON CABLE HANDLE(9630-284)-----	[1PCS]
D10.Ø110 PULLEY(9213-002B)-----	[6PCS]
D11.Ø117 PULLEY(9213-010E)-----	[2PCS]
D12.7320mm STEEL CABLE(FJG1000A)-----	[1PCS]
D13.Ø27.5XØ22X11.5L RUBBER PAD(9214-030)-----	[1PCS]

D1.

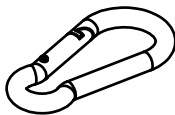

D2.

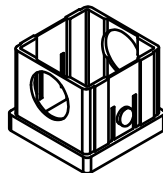

D3.



D4.

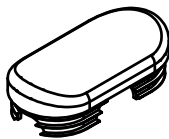

D5.



D6.

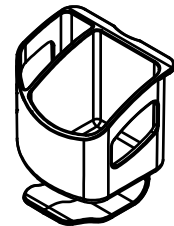

D7.

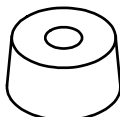

D8.

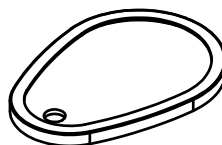

D9.

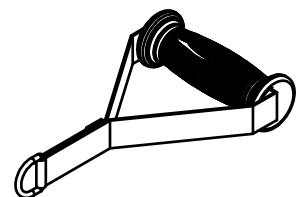

D10.



D11.

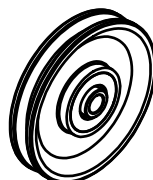

D12.

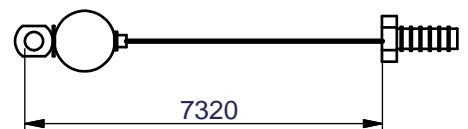

D13.



PARTS ILLUSTRATION SHEET

A [1SET]

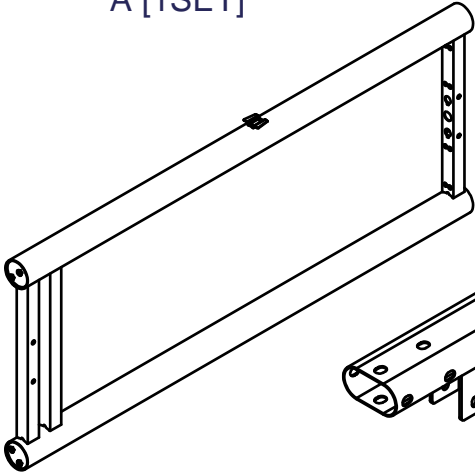

B [1SET]

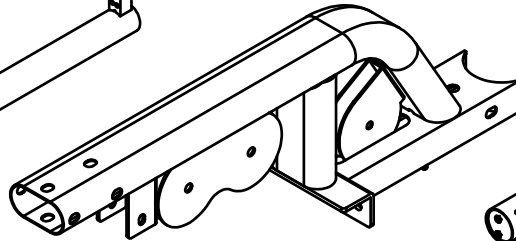

C [1SET]

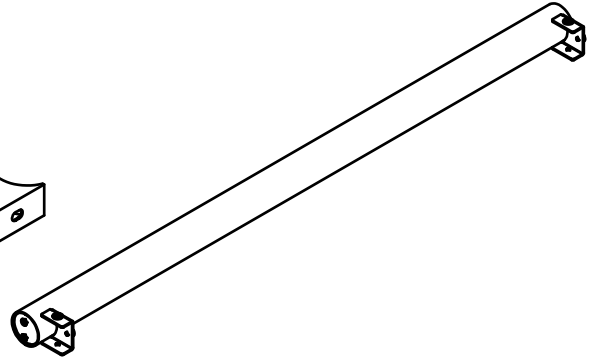

D [1SET]

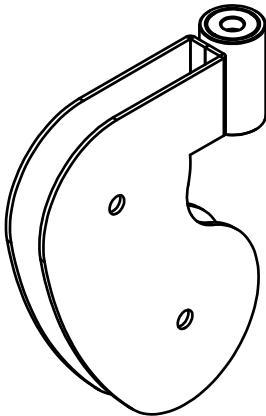

E [1SET]

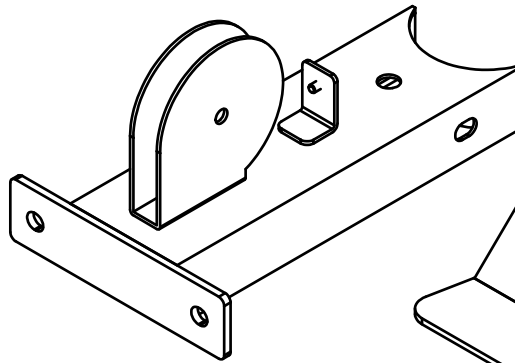

F [1SET]

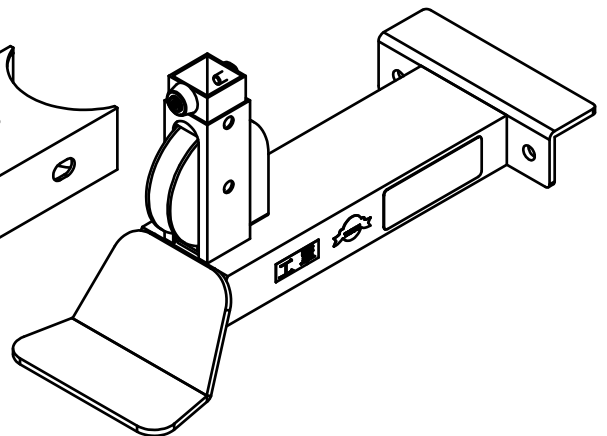

G1 [1SET]
280272

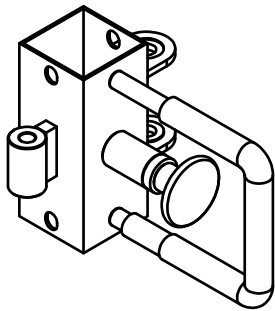

H [1SET]

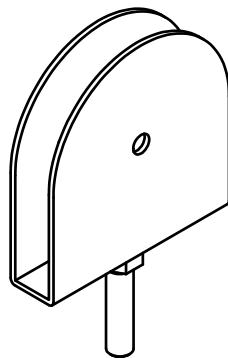

I [2PCS]
8280-014
Ø3/4"X1800L

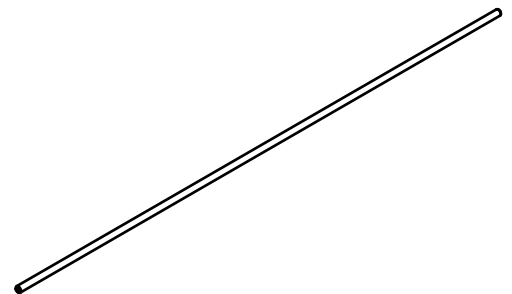

PARTS ILLUSTRATION SHEET

S1 [1PCS]
8210-216
Ø1"X596L

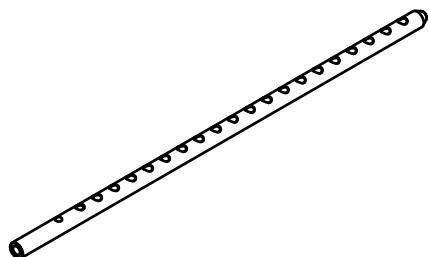

T [1SET]
8400-033

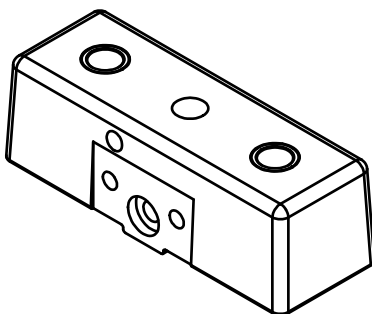

U [1PCS]
8312-077

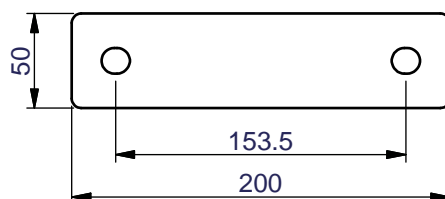

V [3PCS]
8343-324

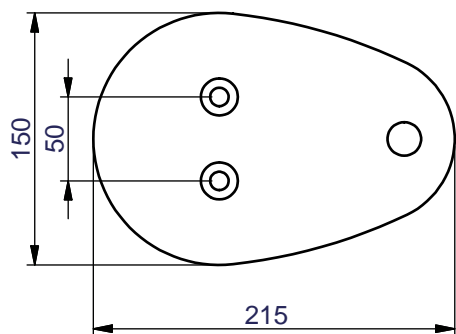

W [2SET]
8321-059

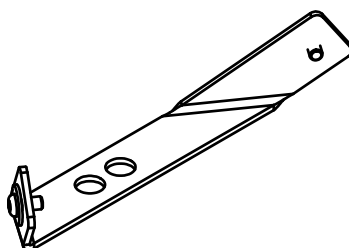

X [2SET]
8321-060

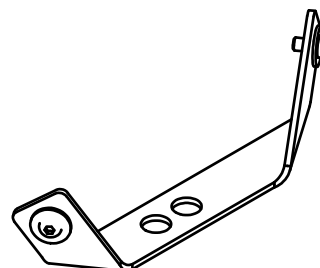

Y [4SET]
8331-070

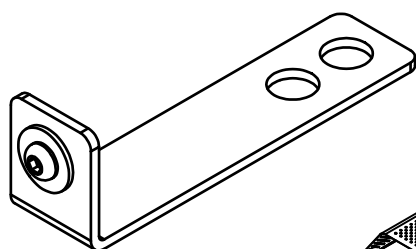

Z [1PCS]
8380-075

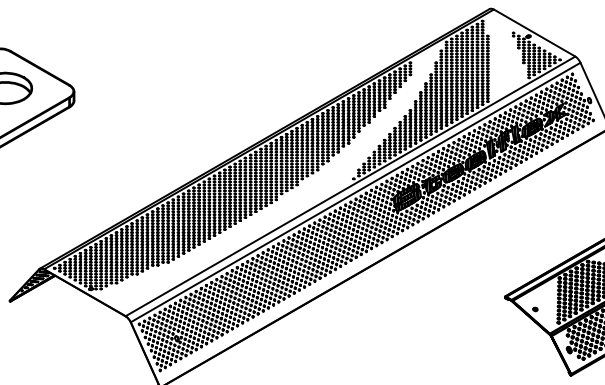

AA [1PCS]
8380-076

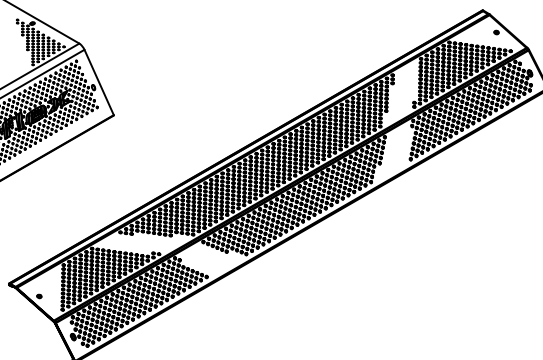

PARTS ILLUSTRATION SHEET

AB[1SET]
8380-076

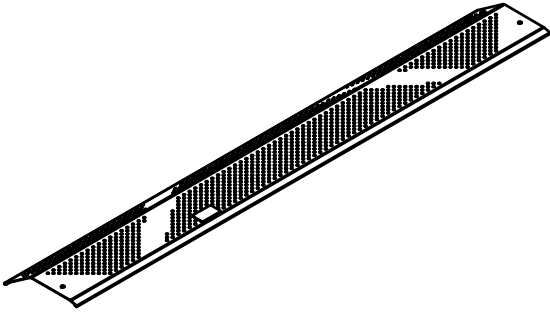

AC[1SET]
260545
□50X1.8tX1900L

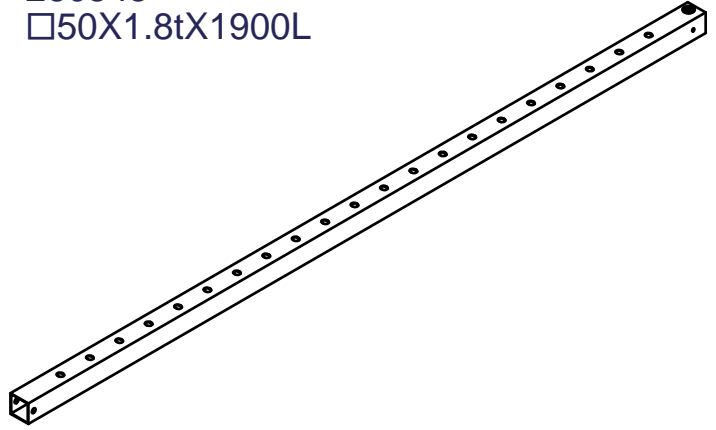

PARTS ILLUSTRATION SHEET

JG is collocated in JG2000, JG5000(S), JG8000(S)

BA[1SET]

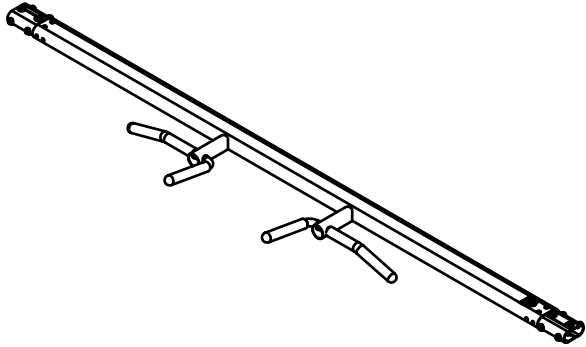

HARDWARE ILLUSTRATION

DD1.Ø49.5X43L CAP COVER(9211-074)----- [2PCS]

DD1.

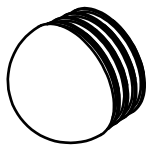

JG1000 ASSEMBLY INSTRUCTIONS

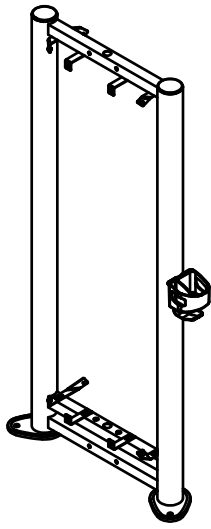

Above shows STEP 1 assembled and completed

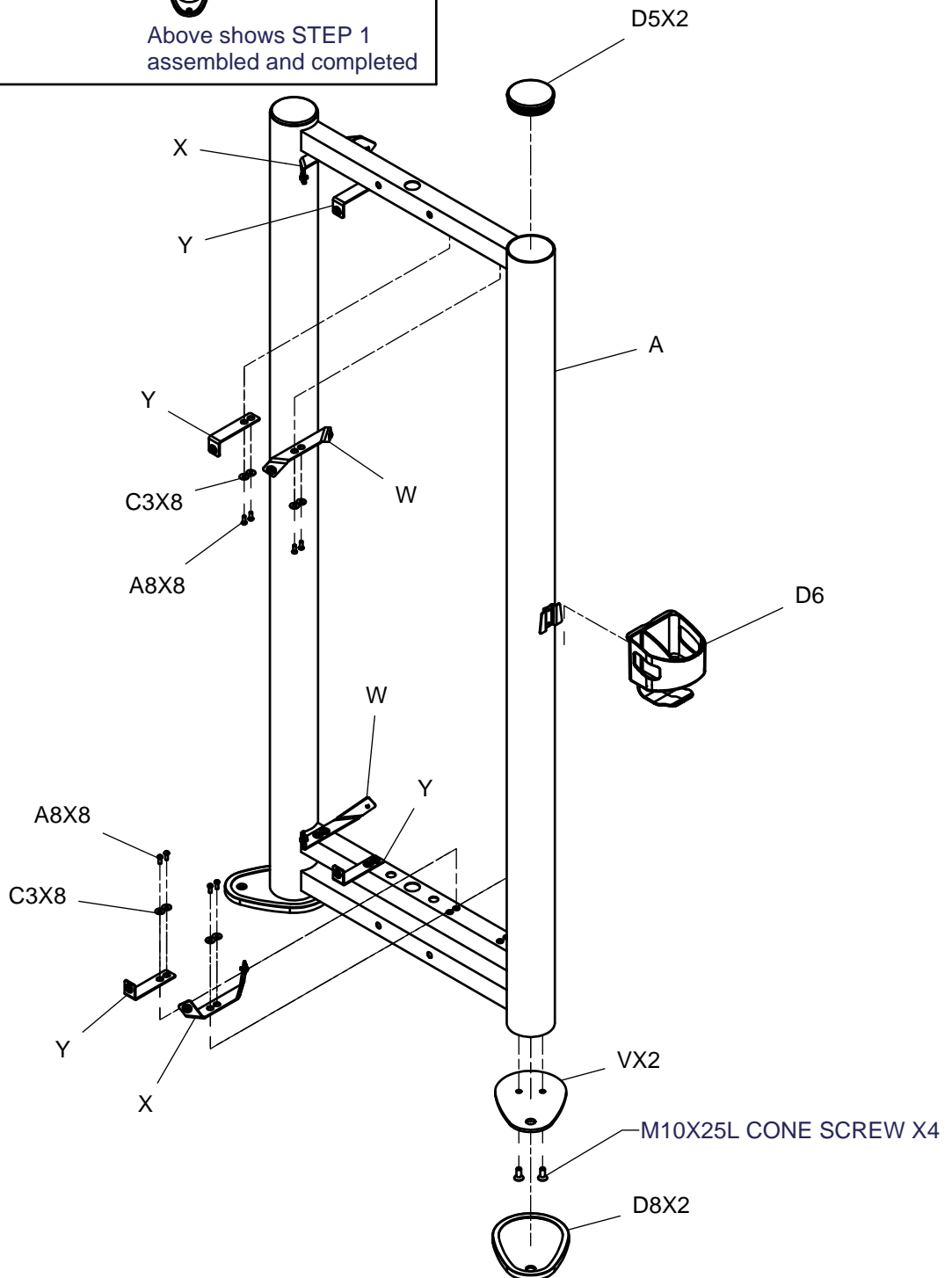

JG1000 ASSEMBLY INSTRUCTIONS

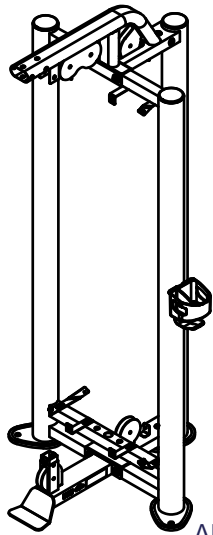

Above shows STEP 2 assembled and completed

M10X15L ROUND INNER HEX SCREW X3

M10-Ø27 WASHER X3

B

D5

B1X2

C1X2

C

U

C1X2

A2X2

M10X15L ROUND INNER HEX SCREW X3

M10-Ø27 WASHER X3

V

M10X25L CONE SCREW X2

E

C1X2

B1X2

D8

F

C1X2

A2X2

Project	Part number	Name	Specification	Quantity	Remark
1	208400-010	weight stack plate		1	
2	8280-014	GUIDE RODS		2	
3	8311-194	plate	38X2TX167	1	
4	8400-033	TOP PLATE		1	
5	9211-046	SHAFT COLLAR	Ø(40X25.7)XØ19.5X35L	2	
6	9310-027	RUBBER DONUT	Ø55XØ19.5X32L	2	
7	JG1000-P08L	WEIGHT STACK FRAME		1	

Note:

Part #3 have to be installed after part #6
and before the installation of weight plates set (Part #1)

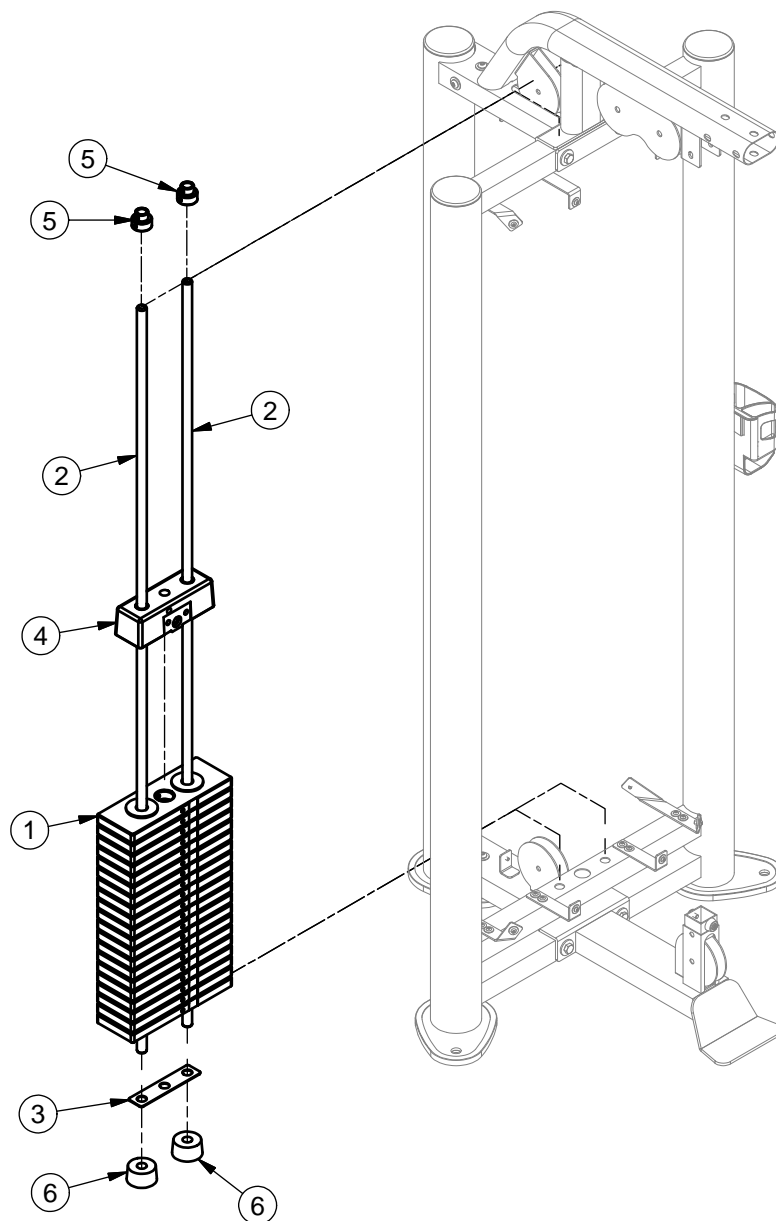

JG1000 ASSEMBLY INSTRUCTIONS

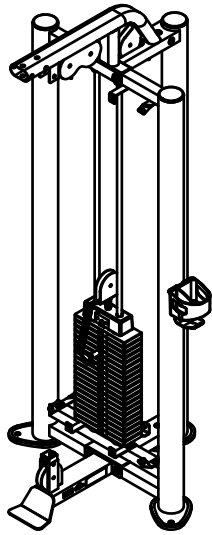

Above shows STEP 3 assembled and completed

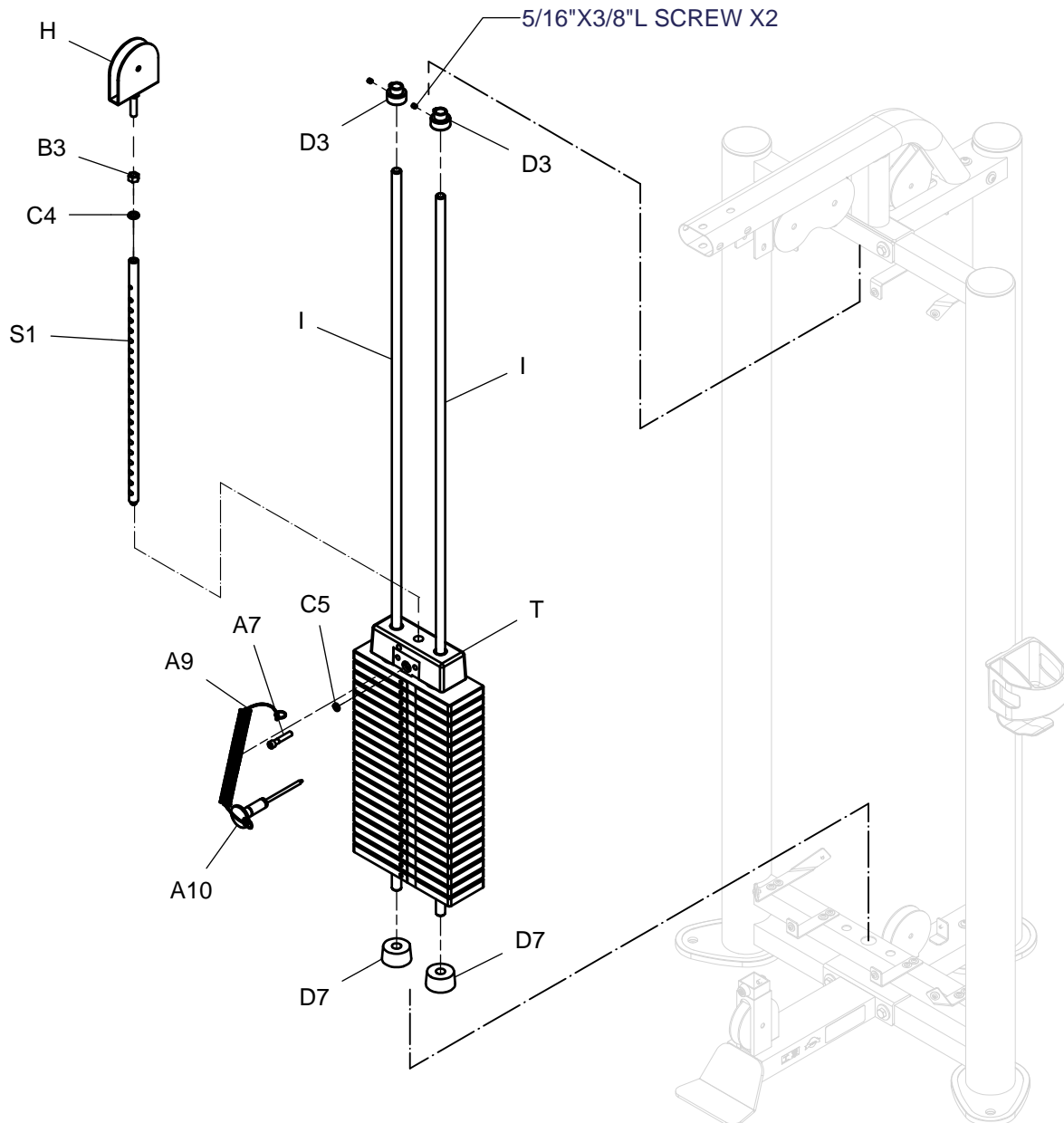

JG1000 ASSEMBLY INSTRUCTIONS

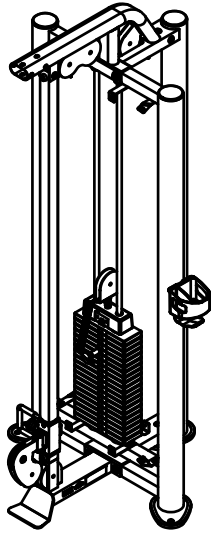

Above shows STEP 4.1 assembled and completed

When buying JG2000, JG5000,
Please replace one of the JG1000 ~ G1
see the following picture.

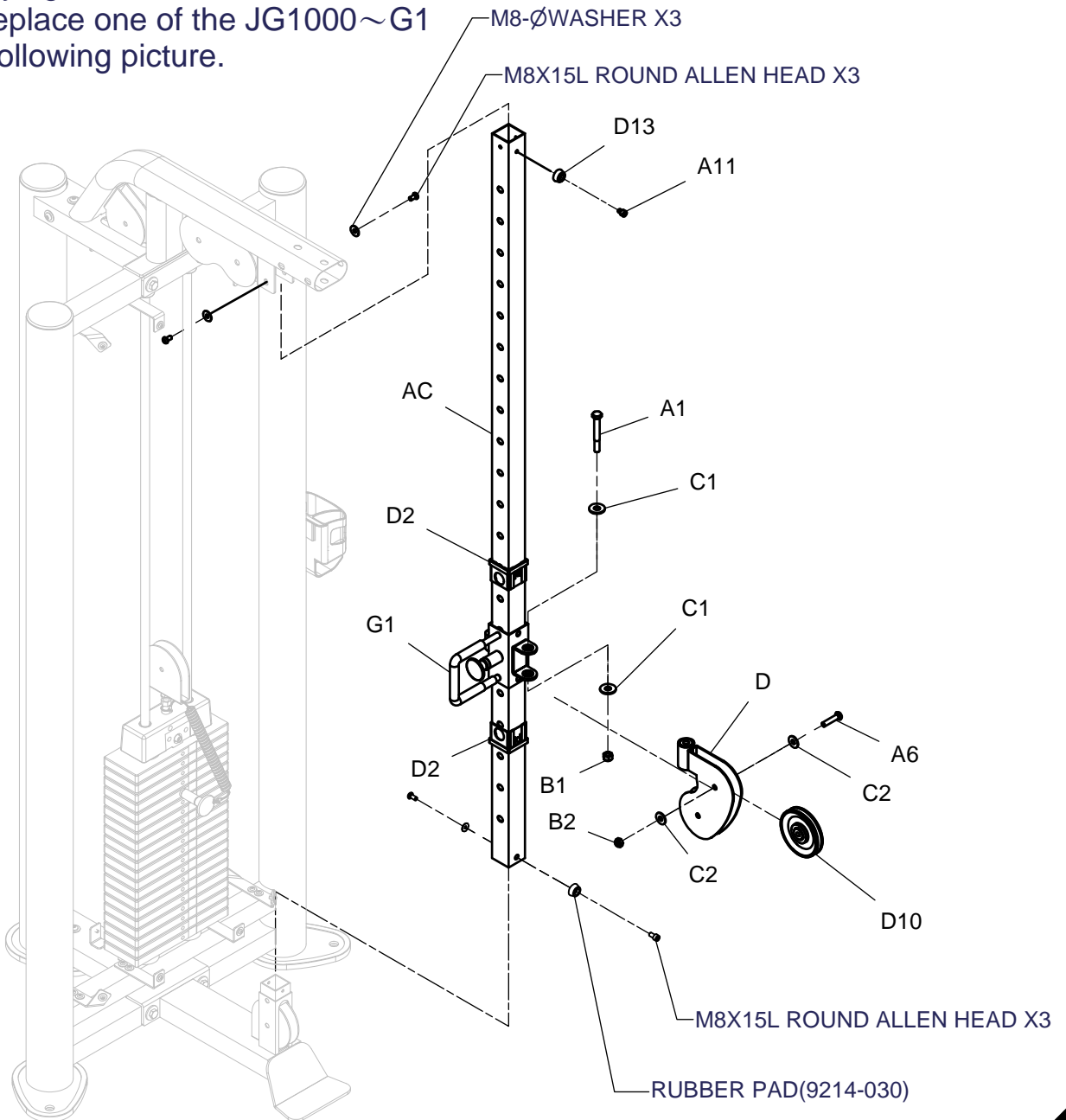

JG1000 ASSEMBLY INSTRUCTIONS

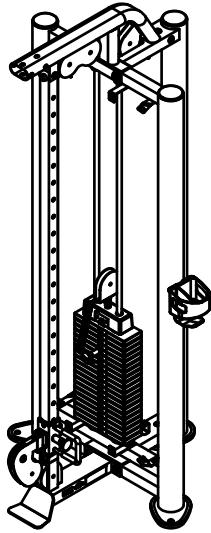

Above shows STEP 4 assembled and completed

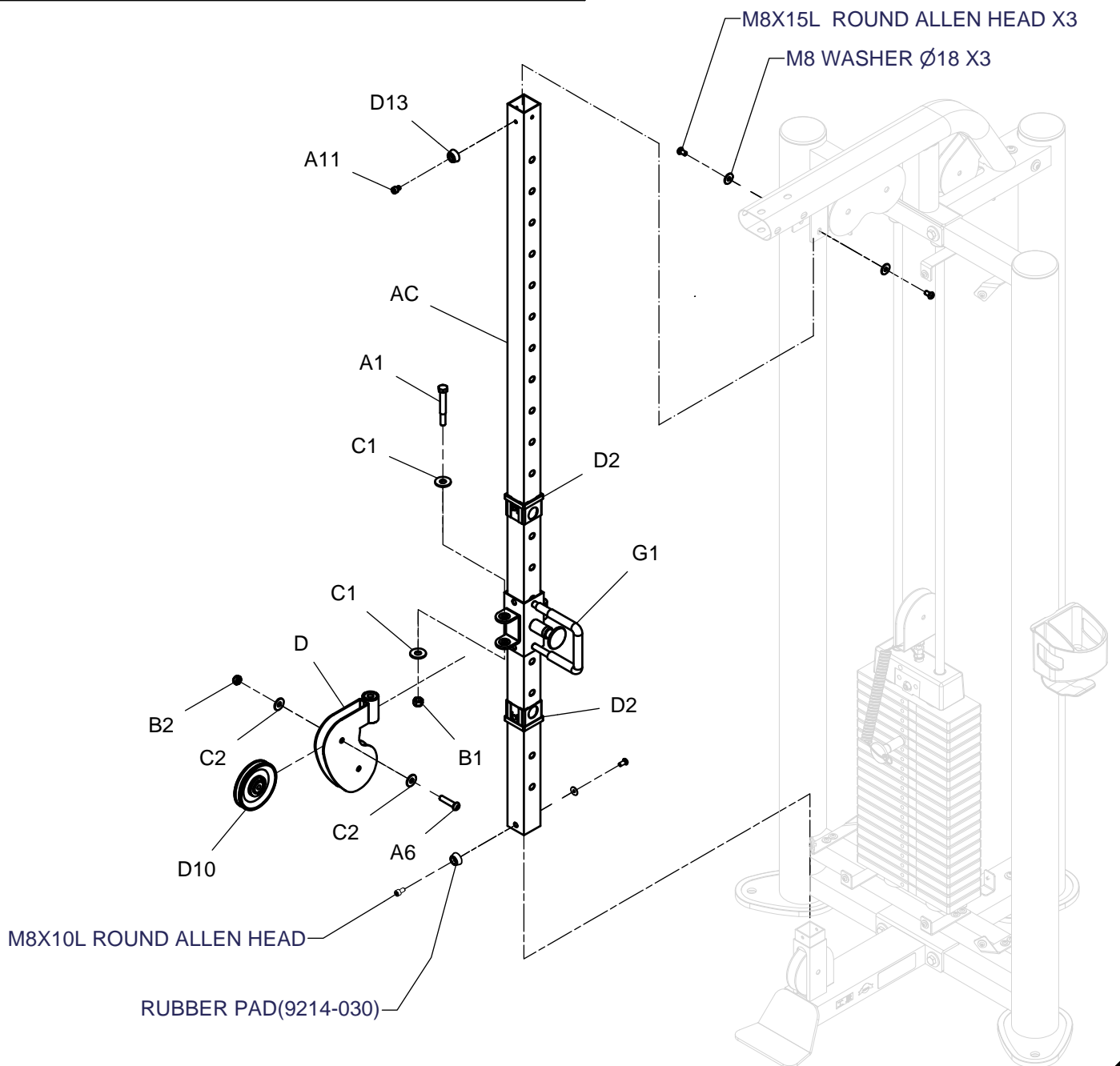

JG1000 ASSEMBLY INSTRUCTIONS

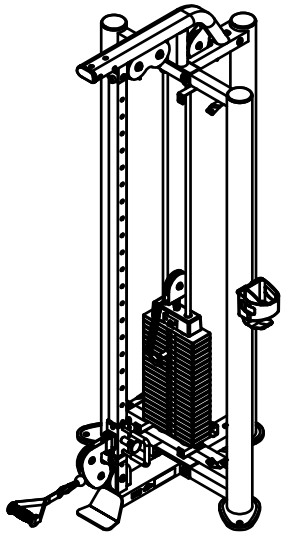

Above shows STEP 5 assembled and completed

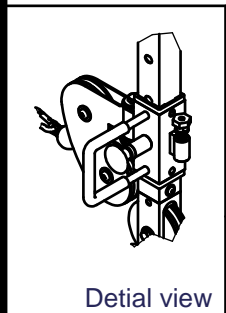
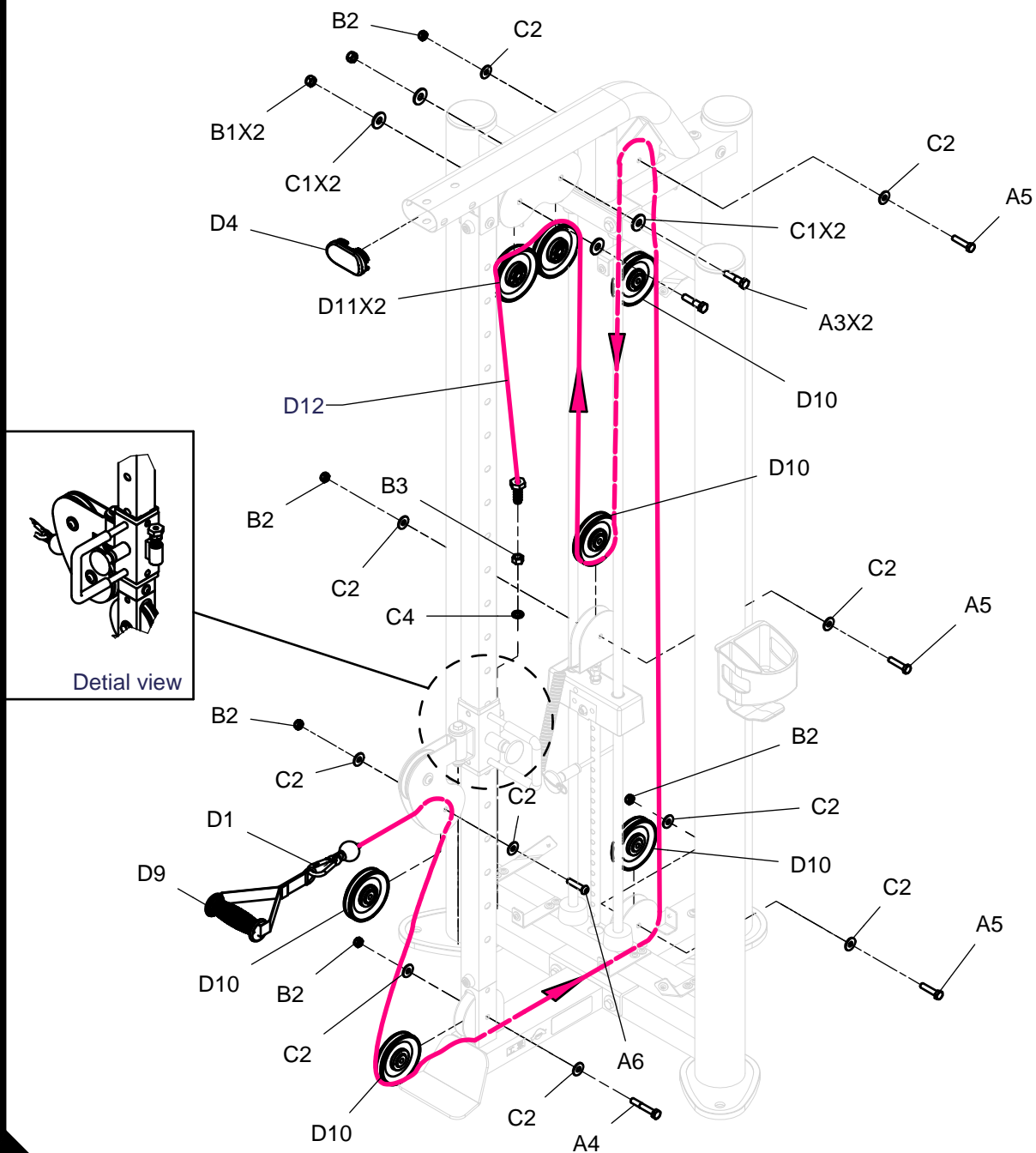

Detail view

JG1000 ASSEMBLY INSTRUCTIONS

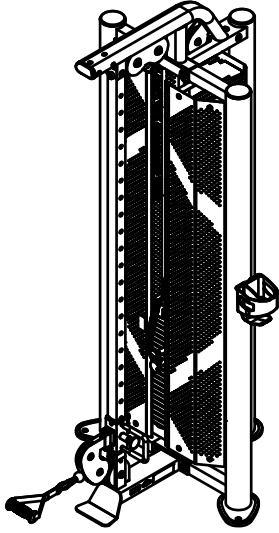

Above shows STEP 12
assembled and completed

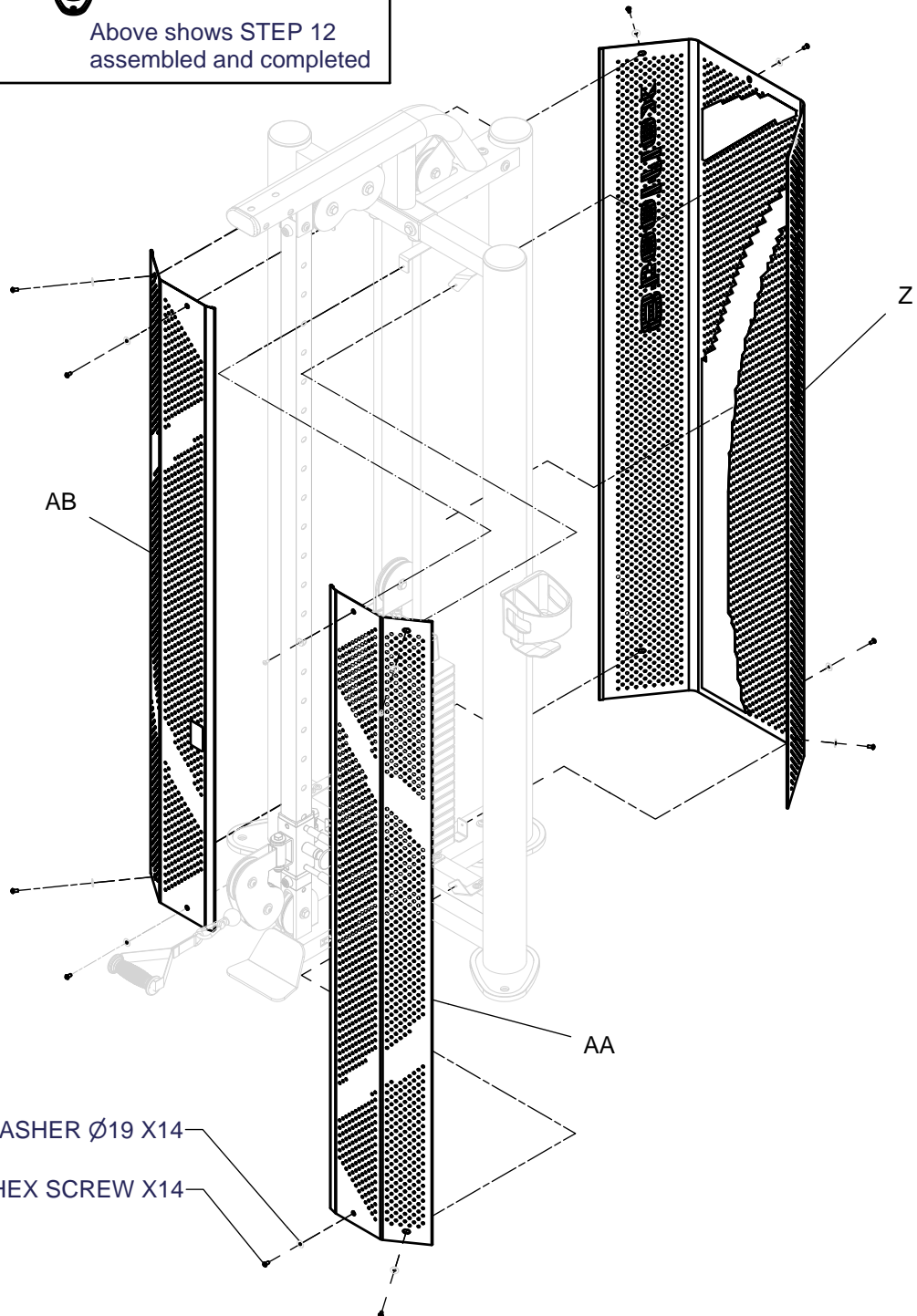

M6 WASHER Ø19 X14

M6X16 ROUND INNER HEX SCREW X14

JG1000 ASSEMBLY INSTRUCTIONS

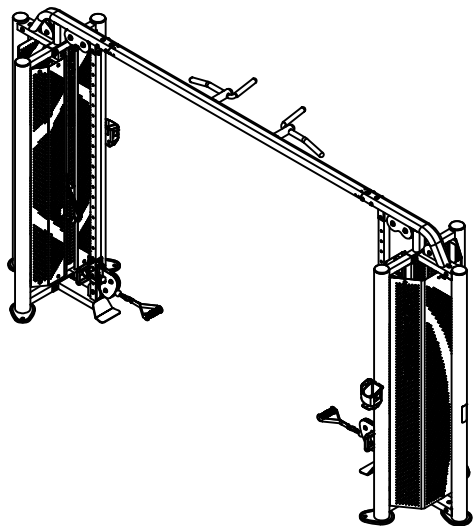

Above shows JG2000 assembled and completed

When buying JG2000, following the diagram of assembling

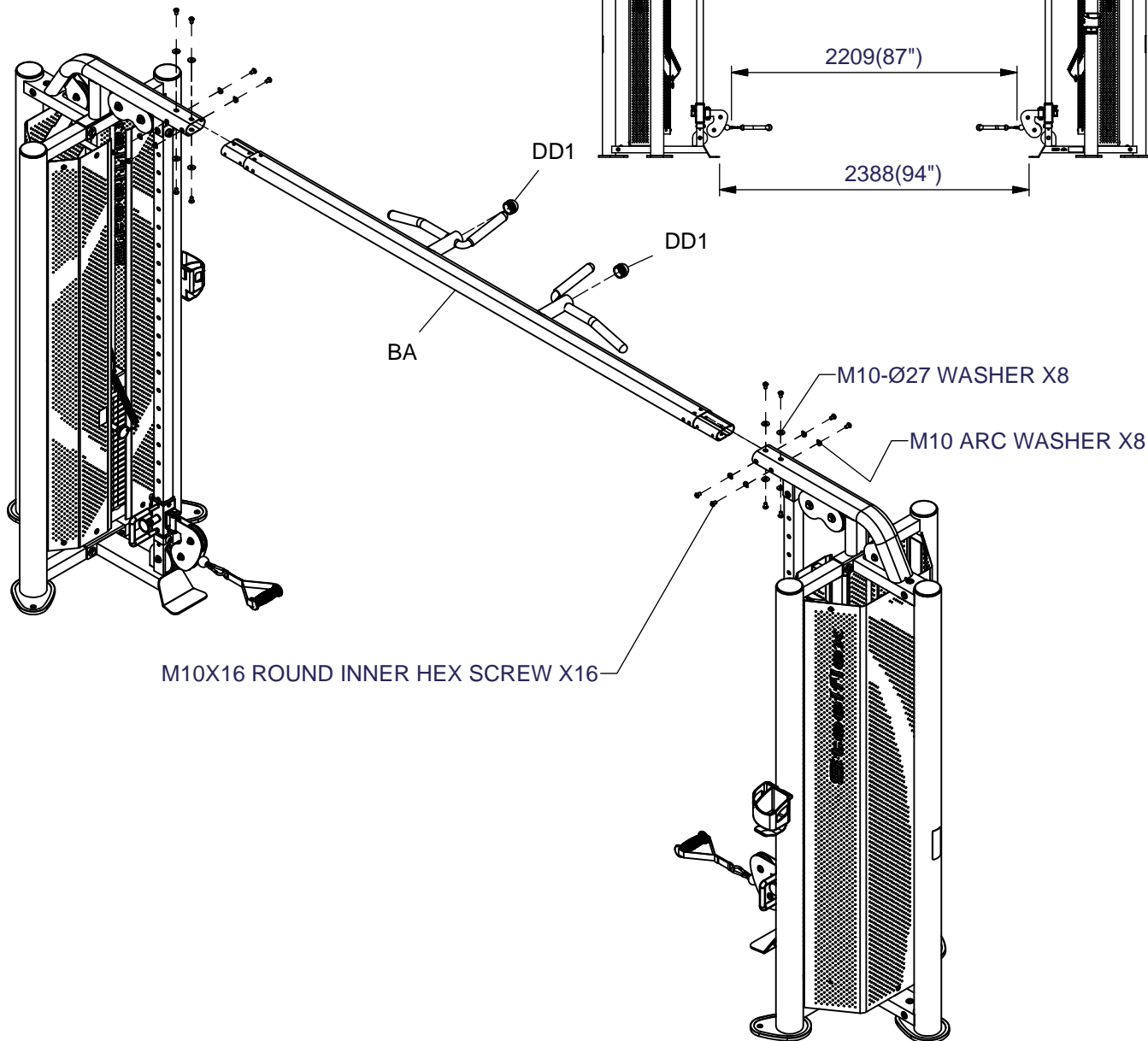
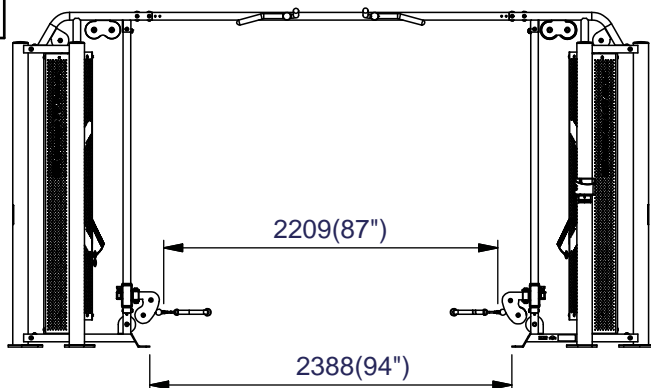

JG1000 ASSEMBLY INSTRUCTIONS

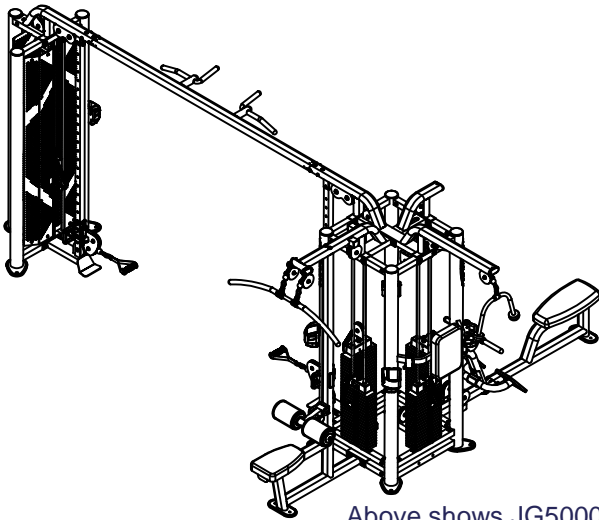

Above shows JG5000 assembled and completed

When buying JG5000, following the diagram of assembling

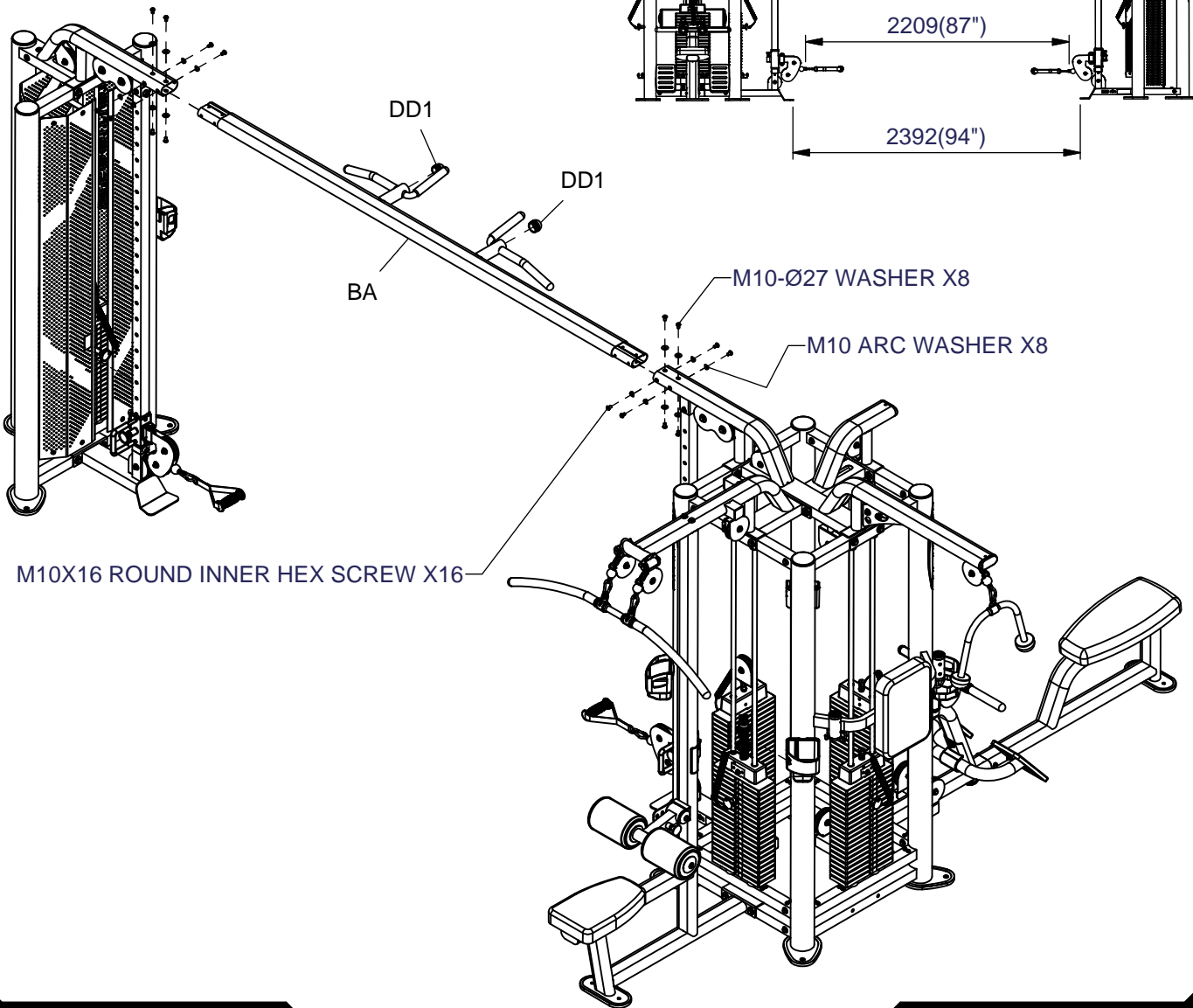
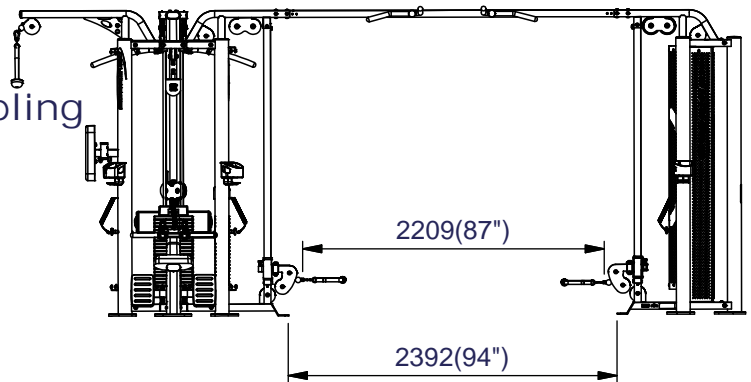

JG1000 ASSEMBLY INSTRUCTIONS

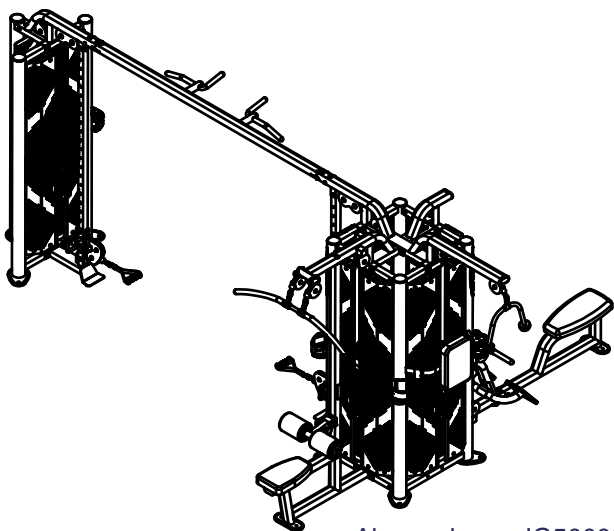

Above shows JG5000S assembled and completed

When buying JG5000S, following the diagram of assembling

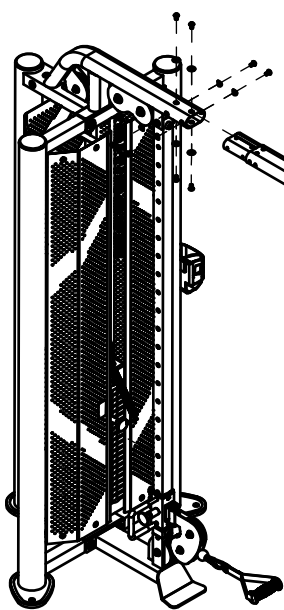
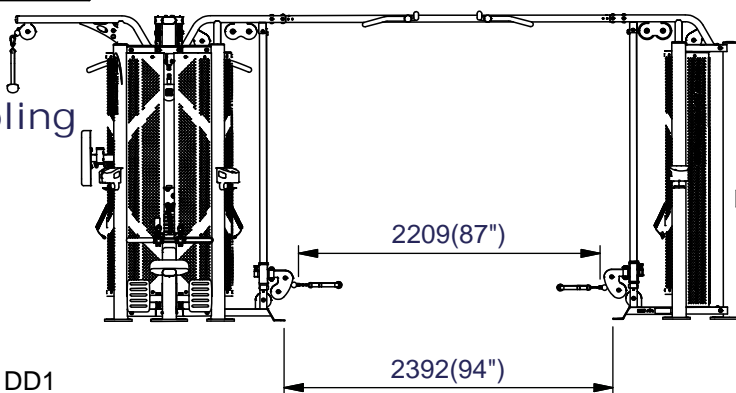

DD1
DD1
BA

M10-Ø27 WASHER X8

M10 ARC WASHER X8

M10X16 ROUND INNER HEX SCREW X16

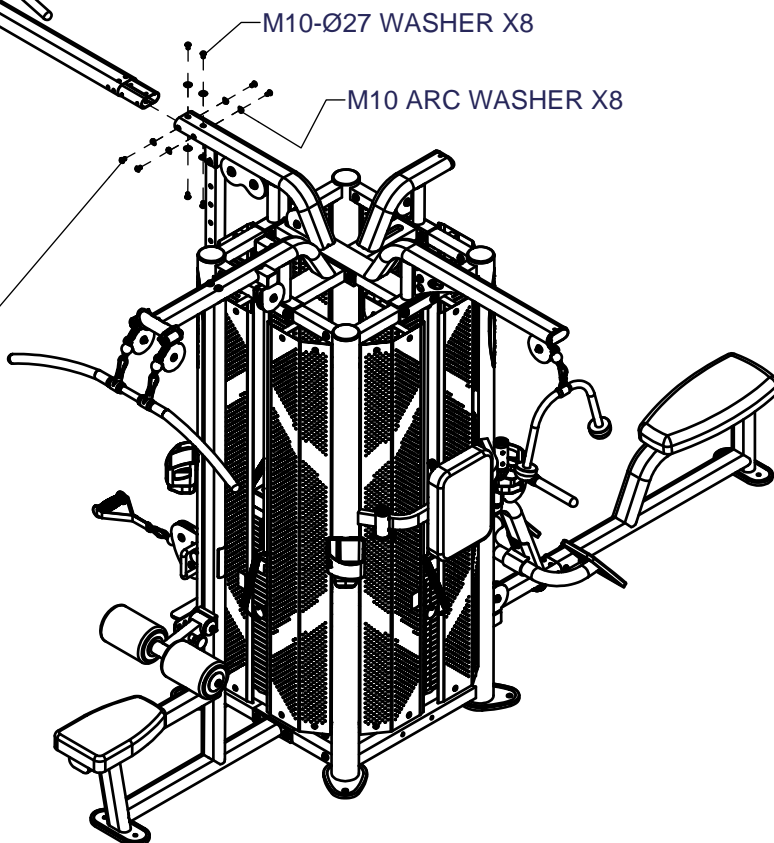

Guide on Selector Rod Adjustment

STEP 1

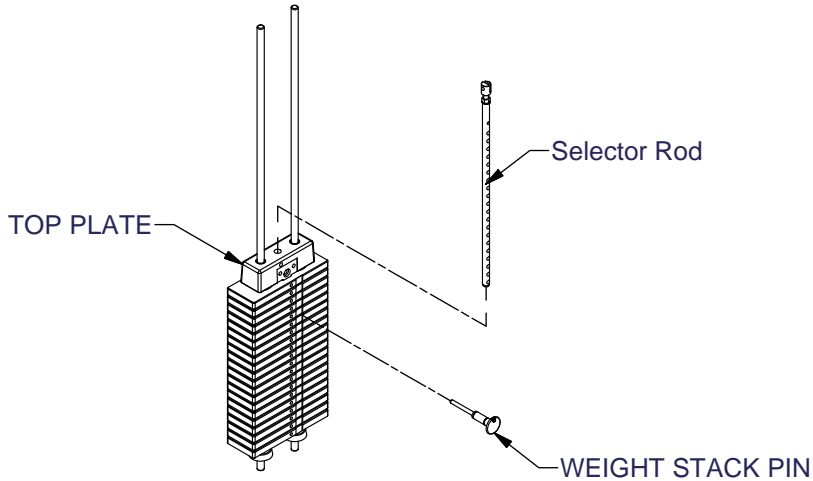

Step 1

Place Selector Rod into Top Plate.

Then put selector pin into the weight plate to fix the rod.

STEP 2

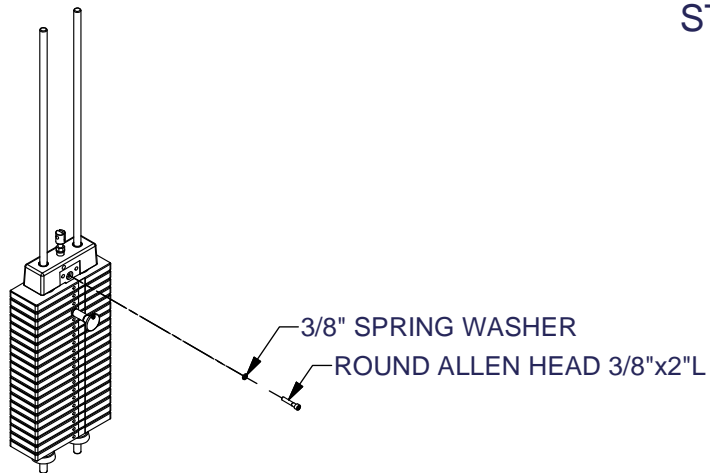

Step 2

Screw the 3/8"x2"L Round Allen Head into Top Plate but not tighten it up.

STEP 3

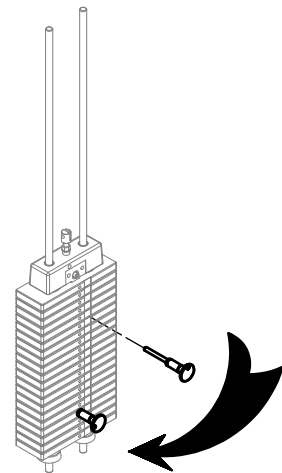

Step 3

Place the selector pin to each weight plate (5,10,15,20...) to check the smoothness.

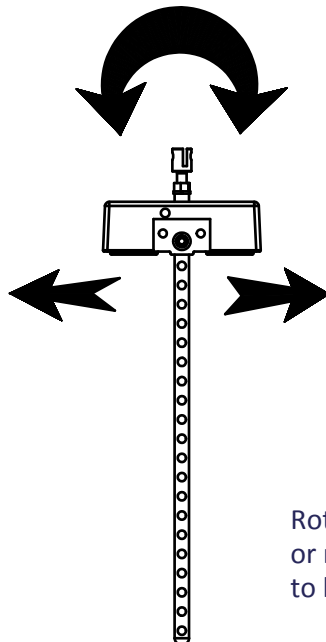

Rotate the Selector Rod slightly or move the 3/8"x2"L Round Allen Head to left and right and repeat Step 3.

MEGA POWER series JUNGLE GYM series

project	Part number	Name	Specification	Quantity	Remark
1	38-200 CAP	round allen head	3/8"X2"L round allen head-CAP	1	
2	38-SPWAS 8732003	3/8" spring washer		1	
3	8210-216C	20 hole Selector Rod		1	
4	8250-166	pin	Ø7.9X137L	1	
5	8250-162	weight stack pin	Ø7X110L	1	
6	8400-010	10LB weight stack plate	102x22tx280L 10LB	20	
7	8400-033	top plate		1	

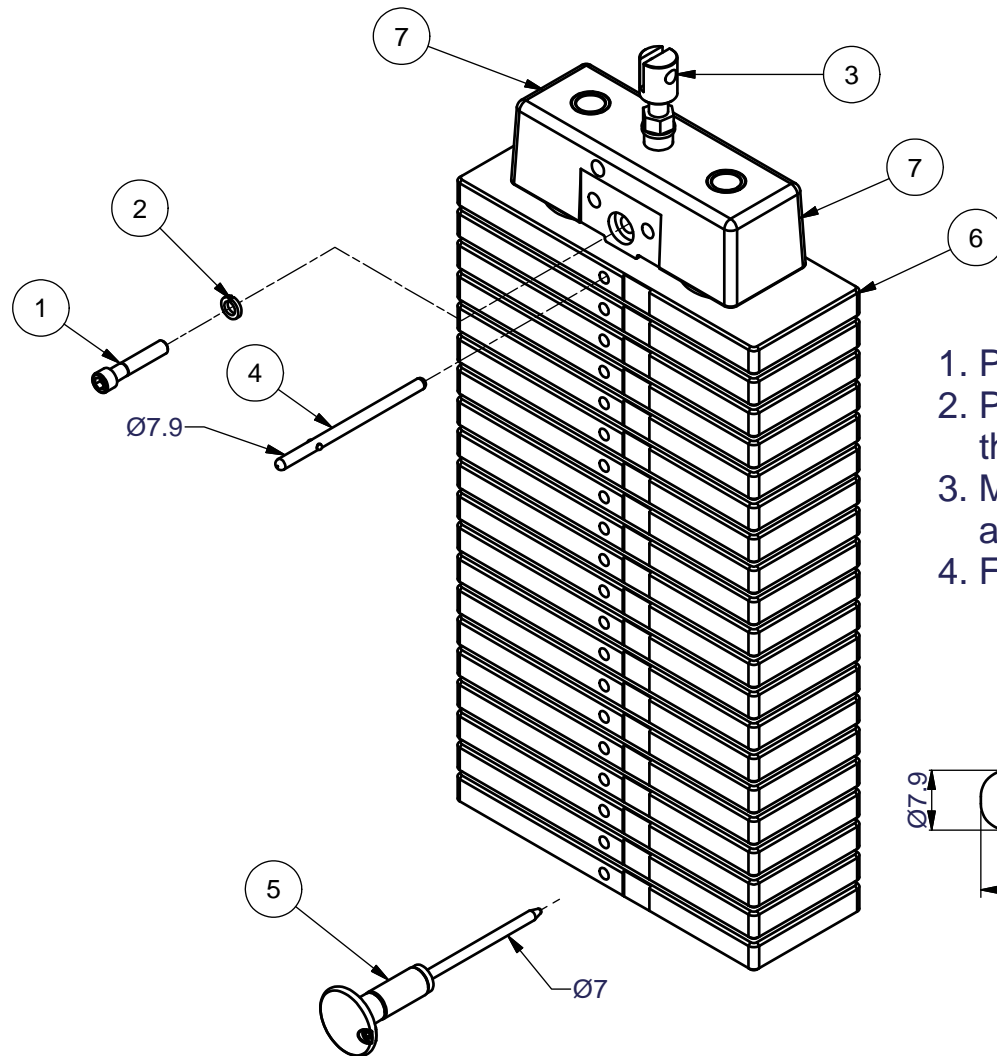

1. Place #4 - 8250-166 (pin) into the first weight plate.
2. Place #5 - 8250-162 (weight stack pin) into the the hole 20th of the weight stack.
3. Make sure #7 (top plate) cling to #6 (first weight plate) and fix in #1 - 3/8"X2"L screw and #2 - 3/8" spring washer.
4. Finally remove #5 - 8250-162 (weight stack pin) and use as usual.

