

Two-Stage, Belt Drive, Gasoline Engine Driven Air Compressor

En deux étapes, la courroie d'entraînement, Gasoline Engine Driven Compresseur d'air

De dos etapas, la correa de transmisión, el motor de gasolina conducido compresor de aire

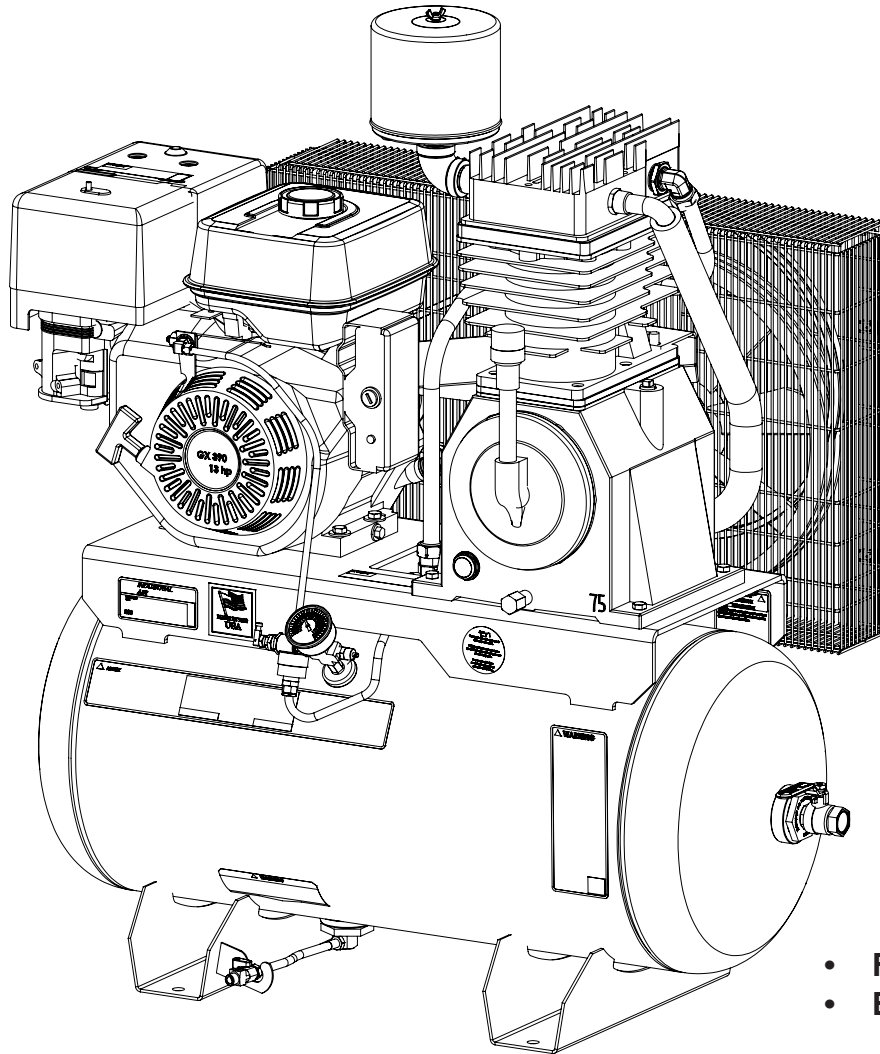

- Français, p. 13-23
- Español, p. 24-34

⚠ WARNING: Read and understand all safety precautions in this manual before operating. Failure to comply with instructions in this manual could result in personal injury, property damage, and/or voiding of your warranty. The manufacturer **WILL NOT** be liable for any damage because of failure to follow these instructions.

⚠ AVERTISSEMENT: Lire et s'assurer de bien comprendre toutes les consignes de sécurité du présent manuel avant d'utiliser l'outil. Toute dérogation aux instructions contenues dans ce manuel peut entraîner l'annulation de la garantie, causer des blessures et/ou des dommages matériels. Le fabricant **NE SAURA** être tenu responsable de dommages résultant de l'inobservation de ces instructions.

⚠ ADVERTENCIA: Lea y comprenda todas las precauciones de seguridad contenidas en este manual antes de utilizar esta herramienta. El no cumplir con las instrucciones de este manual podría dar como resultado la anulación de su garantía, lesiones personales y/o daños a la propiedad. El fabricante **NO SERA** responsable de cualquier daño debido a no acatar estas instrucciones.

TABLE OF CONTENTS

SAFETY GUIDELINES.....	2-3	SERVICE INTERVAL	9
OVERVIEW	4	TROUBLESHOOTING CHART	10
ASSEMBLY	4-5		
COMPRESSOR CONTROLS.....	5		
OPERATING INSTRUCTIONS	6		
MAINTENANCE	7-9		

SAFETY GUIDELINES

The following information relates to protecting YOUR SAFETY and PREVENTING EQUIPMENT PROBLEMS. To help you recognize this information, we use the following symbols. Please read the manual and pay attention to these sections.







⚠ DANGER: – A POTENTIAL HAZARD THAT WILL CAUSE SERIOUS INJURY OR LOSS OF LIFE.

⚠ WARNING: – A POTENTIAL HAZARD THAT COULD CAUSE SERIOUS INJURY OR LOSS OF LIFE.









⚠ CAUTION: – A POTENTIAL HAZARD THAT MAY CAUSE MODERATE INJURY OR DAMAGE TO EQUIPMENT.

IMPORTANT SAFETY INSTRUCTIONS

⚠ WARNING:

	RISK OF FIRE OR EXPLOSION.	Never spray flammable liquids in a confined area. If sparks come into contact with vapors from gasoline or other solvents, they may ignite, causing fire or explosion. Always operate the compressor in a well-ventilated area. Do not smoke while spraying. Do not spray where sparks or flame are present. Keep compressor as far from spray area as possible. Store flammable materials in a secure location away from compressor. Equip the area of operation with a fire extinguisher.
	RISK OF BURSTING.	Do not weld, drill or modify the air tank of this compressor. Welding or modifications on the air compressor tank can severely impair tank strength and cause an extremely hazardous condition. Welding or modifying the tank in any manner will void the warranty. If tank develops a leak, replace it immediately with a new tank or replace the entire compressor.
	RISK OF BURSTING.	Check the manufacturer's maximum pressure rating for air tools and accessories. Compressor outlet pressure must be regulated so as to never exceed the maximum pressure rating of the tool. Relieve all pressure through the hose before attaching or removing accessories. Never use compressor to inflate small low pressure objects such as children's toys, footballs, basketballs, etc.
	RISK OF BURNS.	High temperatures are generated by the gasoline engine, transfer tube, and the pump. To prevent burns or other injuries, DO NOT touch these items while the engine is running. Allow them to cool before handling or servicing. Keep children away from the compressor at all times. Do not reach around protective shrouds or attempt to maintenance until unit has been allowed to cool.
	RISK TO BREATHING/ INHALATION HAZARD.	Always wear MSHA/NIOSH approved, properly fitting face mask or respirator and work in a well ventilated area when using tools that generate dust. Some dust created by power sanding, grinding, drilling and other construction activities contains chemicals known (to the State of California) to cause cancer, birth defects or other reproductive harm. Some examples of these chemicals are: <ul style="list-style-type: none"> • lead from lead-based paints • crystalline silica from bricks and cement and other masonry products • arsenic and chromium from chemically treated lumber.
	RISK TO BREATHING.	Be certain to read all labels when you are spraying paints or toxic materials, and follow the safety instructions provided on the label or safety sheets for the materials you are spraying. Use a MSHA/NIOSH approved respirator mask if there is a chance of inhaling anything you are spraying. Read all instructions and be sure that your respirator mask will protect you. Work in an area with good cross ventilation.
	RISK OF EYE INJURY.	Always wear ANSI Z87.1 approved safety goggles when using an air compressor. Never point any nozzle or sprayer toward a person, animal or any part of the body. Equipment can cause serious injury if the spray penetrates the skin.

IMPORTANT SAFETY INSTRUCTIONS

 <p>RISK OF BURSTING.</p>	<ul style="list-style-type: none"> •Do not adjust the tank safety valve for any reason. Doing so voids all warranties. The safety valve has been pre-set at the factory for the maximum pressure of this unit. Personal injury and /or property damage may result if the relief valve is tampered with. •Do not use plastic or pvc pipe for compressed air. Use only galvanized steel pipe and fittings for compressed air distribution lines.
 <p>RISK TO BREATHING.</p>	<p>Risk of carbon monoxide poisoning. Engine exhaust contains carbon monoxide, an odorless and deadly poison. DO NOT operate in an enclosed area. DO NOT mount or operate in an enclosed vehicle, such as a van.</p>
 <p>RISK OF FIRE OR EXPLOSION.</p>	<p>Never operate the gasoline engine without the muffler properly installed; doing so allows hot engine exhaust or sparks to vent directly toward the gasoline tank.</p>
 <p>RISK OF FIRE OR EXPLOSION.</p>	<p>Gasoline is flammable and gasoline vapors are explosive. Sparking or heat from engine, or from other sources, can ignite gasoline.</p> <ul style="list-style-type: none"> – DO NOT start or operate with fuel cap removed. – DO NOT refuel while engine is running or still hot. – DO NOT overfill the tank—there should be no fuel in the filler neck. – DO NOT start or operate if spilled gasoline or smell of gasoline is present. – Operate and refuel only in a well-ventilated area. – DO NOT store where gasoline vapors can reach: <ul style="list-style-type: none"> – an open flame – a pilot light, such as in a stove, furnace or water heater – a spark.
 <p>RISK OF FIRE.</p>	<p>Unattended operation of this compressor could result in personal injury or property damage. To reduce the risk of fire, do not allow the compressor to operate unattended.</p>
 <p>RISK TO BREATHING.</p>	<p>Air obtained directly from the compressor should never be used to supply air for human consumption. The air stream may contain carbon monoxide, toxic vapors, or solid particles from tank. Breathing these contaminant's can cause serious injury or death. In order to use air produced by this compressor for breathing, suitable filters and in-line safety equipment must be properly installed. In-line filters and safety equipment must be properly installed. In-line filters and safety equipment used in conjunction with the compressor must be capable of treating air to all applicable local and federal codes prior to human consumption.</p>
 <p>RISK OF INJURY.</p>	<p>Always operate the compressor in a stable secure position to prevent accidental movement of the unit.</p>
 <p>RISK TO HEARING.</p>	<p>Always wear hearing protection when using an air compressor. Failure to do so may result in hearing loss.</p>
<p>⚠ WARNING:</p>	<p>CALIFORNIA PROPOSITION 65 WARNING: This product contains chemicals known to the State of California to cause cancer, birth defects and/or reproductive harm.</p>

⚠ CAUTION:

- Drain the moisture from the tank on a daily basis. A clean, dry tank will help prevent corrosion.
- Pull the tank safety valve ring daily to ensure that the valve is functioning properly, and to clear the valve of any possible obstructions.
- To provide proper ventilation for cooling, the compressor must be kept a minimum of 12 inches (31 cm) from the nearest wall, in a well-ventilated area. Restricting any of the compressor ventilation openings will cause overheating and could cause fire, never place objects against or on top of compressor.
- Fasten the compressor down securely if transporting is necessary. Pressure must be released from the tank before transporting.
- Protect the air hose and interconnect cord from damage and puncture. Inspect them weekly for weak or worn spots, and replace if necessary.
- On oil-lubed compressors, oil can leak or spill and could result in fire or breathing hazard. Oil leaks will damage paint, carpet or other surfaces in vehicles or trailers. Always place the compressor on a protective mat when transporting to protect against damage to vehicle from leaks.
- To prevent damage to tank and compressor on stationary models, the tank must be shimmed so the pump base is level within 1/8" to distribute oil properly. All feet must be supported, shimming where necessary, prior to attaching to the floor. Fasten all feet to floor. We also recommend the use of vibration pads (094-0137) under tank feet.

OVERVIEW

BASIC AIR COMPRESSOR COMPONENTS

The basic components of the air compressor are the gasoline engine, pump, tank(s) and unloader.

The **gasoline engine** (see **A**) powers the pump. The engine drives a pulley and belt, which transfers power from the engine to the pump pistons via a flywheel and a crankshaft. The flywheel fan helps cool the pump.

The **pump** (see **B**) compresses the air and discharges it into the tank. As the piston in the pump cylinder moves downward, air enters the cylinder through the filter and air intake valves at atmospheric pressure. As the piston moves upward, it compresses the air and discharges it into the tank through a check valve.

The **tank** (see **C**) store the compressed air. A check valve at the tank inlet prevents the compressed air in the tank from flowing back into the pump.

When the air pressure in the tank reaches the factory-set limit, the **unloader** (see **D**) relieves air pressure in the pump and transfer tubes and switches the engine to idle. As compressed air is used and the pressure level in the tank drops to a pre-set level, the unloader stops relieving pressure in the pump and transfer tube and switches the engine to full speed.

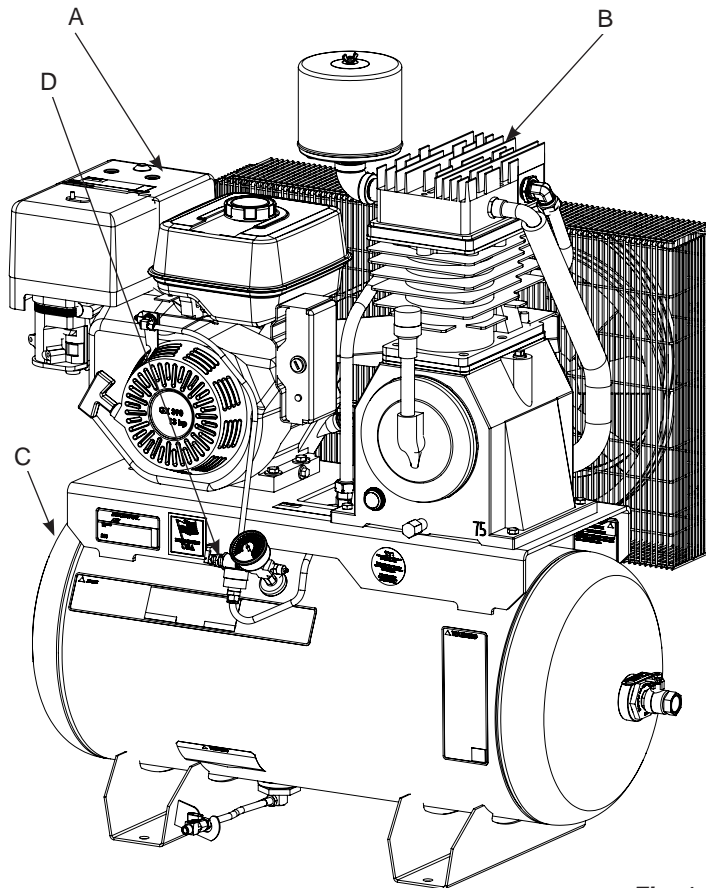

Fig. 1

ASSEMBLY

ASSEMBLING THE COMPRESSOR



This compressor was shipped with oil in the pump crankcase. Check oil before operating the air compressor, see Check Oil under Maintenance.

1. Unpack the air compressor. Inspect the unit for damage. If the unit has been damaged in transit, contact the carrier and complete a damage claim. Do this immediately because there are time limitations to damage claims.

The carton should contain:

- Air compressor
- Vibration pads (qty. 4)
- Operator/parts manual
- Engine manual

2. Check the compressor's serial label to ensure that you have received the model ordered, and that it has the required pressure rating for its intended use.
3. Locate the compressor according to the following guidelines:

! WARNING: Always operate the compressor in a well ventilated area.

- a. The flywheel side of the compressor must be at least 12 inches (31 cm) from any wall or obstruction, in a clean, well-ventilated area, to ensure sufficient air

flow and cooling.

- b. Remove the compressor from the shipping pallet and place it on the floor or a hard, level surface. The compressor must be level to ensure proper lubrication of the pump and good drainage of the moisture in the tank.

NOTE: If the compressor is mounted on a vehicle, the vehicle must be parked on a level surface while operating the compressor. This is to ensure proper lubrication of the pump and gasoline engine.



CAUTION: The shipping pallet is not designed as a base for an operating compressor. Operating the compressor while it is on the pallet will void your warranty.

- c. To prevent damage to tank and pump, the tank must be shimmed so the pump is level within 1/8" per lineal foot *maximum* to distribute oil properly. Fasten to floor and NEVER force tank feet to floor without shims when tightening. We also recommend the use of vibration pads (094-0137) under tank feet (**E**).
4. Connect an air hose or distribution line (not included) to the compressor.

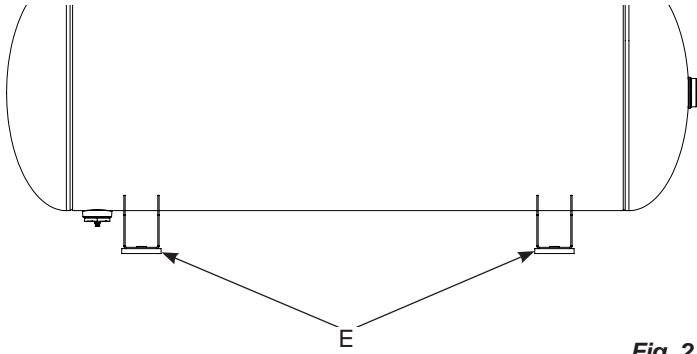

Fig. 2

CONNECTING A BATTERY

- Battery:** A 12 volt sealed battery with a minimum ampere-hour rating of 24 Ah is required (*battery not included*).
- Battery cables:** Select battery cables to avoid greater than .05 volt drop in the cable during starter motor operation.
- Battery Cable size and length: (Gauge x length)**
Positive Cable: AWG No. 4 x 1.5 m (5.0 ft) maximum.
Negative Cable: AWG No. 4 x 2.3 m (7.5 ft) maximum.
- Wiring Precautions:**
 - Connect the battery positive (+) cable (A) to the starter solenoid terminal.
 - Connect the battery negative (-) cable (B) to the engine crankcase or engine frame mounting bolt.
 - Do not route the battery cables on or near any hot, moving or rotating parts or sharp edges. Keep the battery cables and electrical wires away from the fuel line.
 - Protect positive electrical connections with a cover or insulation.

CAUTION: Failure to connect and disconnect in the proper sequence can cause equipment damage. Ensure there is a clean tight fit from the cables to the post.

WARNING: Remove the cable from the negative (-) side of the battery before servicing.

Servicing of batteries are to be performed or supervised by personnel knowledgeable of batteries and the required precau-

tions. Keep unauthorized personnel away from batteries.

BATTERY SAFETY INSTRUCTIONS

WARNING: Lead-acid batteries present a risk of fire because they generate hydrogen gas. The following procedures are to be followed:



- Do not smoke when near batteries.
- Do not cause flame or spark in battery area.
- Discharge static electricity from body before touching batteries by first touching a grounded metal surface.
- Do not dispose of batteries in a fire. The battery is capable of exploding.
- Do not open or mutilate the battery or batteries. Released electrolyte has been known to be harmful to the skin and eyes and to be toxic.

WARNING: A battery presents a risk of electrical shock and a high short circuit current. The following precautions are to be observed when working on batteries:



- Remove watches, rings or other metal objects.
- Use tools with insulated handles.
- Wear rubber gloves.
- Do not lay tools or metal parts on top of batteries.
- Disconnect charging source prior to connecting or disconnecting battery terminals.
- Determine if the battery is inadvertently grounded. When inadvertently grounded, remove source of ground. Contact with any part of a grounded battery is capable of resulting in electrical shock. The risk of such shock is reduced when such grounds are removed during installation and maintenance.
- Failure to connect and disconnect in the proper sequence can cause equipment damage. Ensure there is a clean tight fit from the cables to the post.

COMPRESSOR CONTROLS

Tank Pressure Relief Valve (see A)

If the unloader valve (see B) does not open when pressure reaches the preset level, this valve will pop open automatically to prevent overpressurization. To operate manually, pull the ring on the valve to relieve air pressure in the tank.

Tank Pressure Gauge (see C)

This gauge measures the pressure level of the air stored in the tank. It is not adjustable by the operator, and does *not* indicate line pressure.

Fig. 3

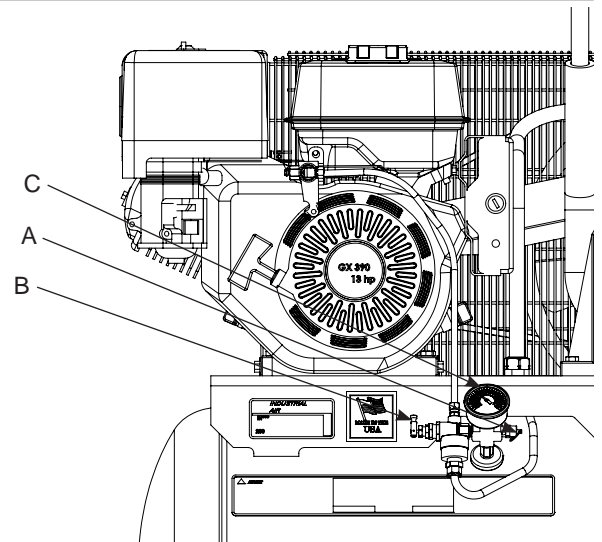

OPERATING INSTRUCTIONS

BREAK-IN OF THE PUMP

NOTE: The pump is shipped with break-in oil which should be changed after the first 8 hours of operation.

NOTE: When references are made to gasoline engine operations, refer to the engine manual for proper procedure.

1. Before starting the compressor for the first time, ensure proper oil level in the gasoline engine crankcase.



⚠ WARNING: Risk of carbon monoxide poisoning. Engine exhaust contains carbon monoxide, an odorless and deadly poison. **DO NOT operate in an enclosed area. DO NOT mount or operate in an enclosed vehicle, such as a van.**

2. Check the oil level in the pump (see "Checking the Oil" in the maintenance section).
3. Fill the tank of the gasoline engine with unleaded gasoline. **DO NOT MIX OIL WITH THE GASOLINE.**
4. Move the unloader lever to the manual start position (see **D**).
5. Open the petcock (see **F**).



⚠ CAUTION: Escaping air and moisture can propel debris that may cause eye injury. **Wear safety goggles when opening petcock.**

6. Start the gasoline engine according to the instructions in the engine manual. Move the unloader lever to the run position (see **C**). Run the compressor for about 30 minutes to break in the internal parts.

NOTE: If the unit does not operate properly, SHUT DOWN IMMEDIATELY, and contact your nearest Service Center or call the factory's Customer Service Department. **DO NOT** return the unit to the store where it was purchased.

7. Shut off the gasoline engine. Close the petcock (see **E**). Connect your air hose to the tank outlet. Check that all connections are tight. A small leak in any of the hoses, transfer tubes, or pipe connections will substantially reduce the performance of your air compressor.

DAILY START-UP

1. Check the oil level in the gasoline engine crankcase. Add oil as necessary. See instructions in the engine manual.
2. Check the oil level in the pump (see "Checking the Oil" in the maintenance section).
3. Fill the tank of the gasoline engine with unleaded gasoline.
4. Move the unloader lever to the start position (see **D**).
5. Close the tank petcock (see **E**).
6. Start the gasoline engine according to the instructions in the engine manual. Run the engine for about one minute to warm up the pump, then move the unloader lever to the run position (see **C**). The pump will begin to fill the tank with air.
7. Do not run the starter motor for more than 5 seconds at a time. Always allow resting for 10 seconds before each starting attempt.



⚠ WARNING: High temperatures are generated by the gasoline engine, transfer tube, and the pump. **To prevent burns or other injuries, DO NOT touch these items while the engine is running. Allow them to cool before handling or servicing. Keep children away from the compressor at all times.**

NOTE: If the unit does not operate properly, SHUT DOWN IMMEDIATELY, and contact your nearest Service Center or call the factory's Customer Service Department. **DO NOT** return the unit to the store where it was purchased.

REPEATED STARTUPS

Move the unloader lever to the start position (see **D**), to relieve pressure in the pump and lines. It is important to do this because if air remains trapped in the pump, it creates a blockage that makes restarting the compressor difficult or impossible.

Do not run the starter motor for more than 5 seconds at a time. Always allow resting for 10 seconds before each starting attempt.

COLD WEATHER STARTING

In cold weather check that the air filters are clean.

NOTE: Use synthetic blend, non-detergent air compressor oil.

Open the petcock (**F**) to depressurize the tank to zero PSI before starting. If the compressor will not start, relocate it in a warmer location.

SHUTDOWN

1. Shut off the gasoline engine.
2. Reduce pressure in the tank through the outlet hose. You can also pull the relief valve ring (see **G**) and keep it open to relieve pressure in the tank.



⚠ CAUTION: Escaping air and moisture can propel debris that may cause eye injury. **Wear safety goggles when opening petcock.**

3. Wear protective eyewear and open the petcock (see **F**) at the bottom of the tank to allow moisture to drain from the tank.

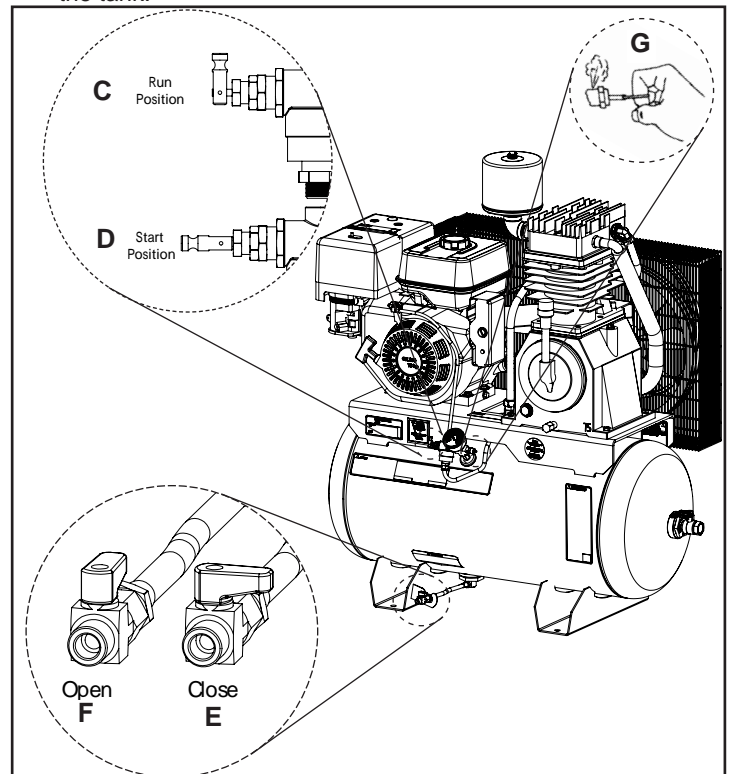

MAINTENANCE

MAINTENANCE

⚠ WARNING: To avoid personal injury, always shut off the gasoline engine and relieve all air pressure from the system before performing any service on the air compressor. Do not use the unit with the shrouds or belt guard removed. Serious injury could occur from contact with moving parts.

Regular maintenance will ensure trouble-free operation. Your gas powered air compressor represents high-quality engineering and construction; however, even high-quality machinery requires periodic maintenance. The items listed below should be inspected on a regular basis.

DRAINING THE TANK

Drain the moisture from the tank (for instructions, see "Shutdown" in the operating instructions section).

⚠ WARNING: Condensation will accumulate in the tank. To prevent corrosion of the tank from the inside, this moisture must be drained at the end of every workday. Wear protective eyewear.

CHECKING THE OIL

Check the level of oil in the pump with the sight glass. The pump oil level must be between **A** and **B**. Do not overfill or underfill.

NOTE: Use synthetic blend, nondetergent air compressor oil.

CHANGING THE OIL

Remove the oil plug (**C**) and drain the oil until it slows to a drip, then close. Unscrew the oil fill plug (**D**) and add compressor oil (refer to parts manual) until it is between full (**A**) and add (**B**). Replace the oil fill plug. Never overfill or under fill the pump.

NOTE: The compressor is pre-filled with synthetic oil. Use synthetic blend, non-detergent air compressor oil.

A = Full
B = Add
C = Oil Plug
D = Oil Fill Plug

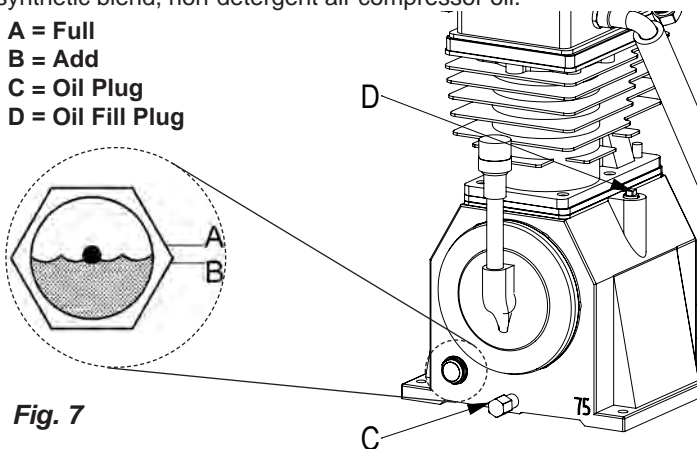

Fig. 7

DRIVE BELT TENSION ADJUSTMENT

NOTE: Drive belt tensioning and pulley alignment are done at the same time. They are discussed separately for clarity.

⚠ WARNING: To avoid personal injury, always shut off the gasoline engine and relieve all air pressure from the system before performing any service on the air compressor. Do not use the unit with the shrouds or belt guard removed. Serious injury could occur from contact with moving parts.

Proper belt tension and pulley alignment must be maintained

for maximum drive efficiency and belt life. The correct tension exists if a deflection (see **A**) of 1/2" (13 mm) occurs by placing 10 lbs. (4.6 kg) of force (see **B**) midway between the motor pulley and the pump flywheel (See **Fig. 8**). This deflection can be adjusted by the following procedure. The pulley should be carefully aligned with the flywheel, and all setscrews should be kept tight.

1. Remove the front of the beltguard by removing the screws and washers using a Torx T25 bit.
2. Loosen the engine mounting bolts.
3. Shift the engine to the point where the correct deflection exists.
4. Retighten the engine mounting bolts.
5. Check to ensure that the tension remained correct.
6. Reinstall the belt guard. All moving parts must be guarded.

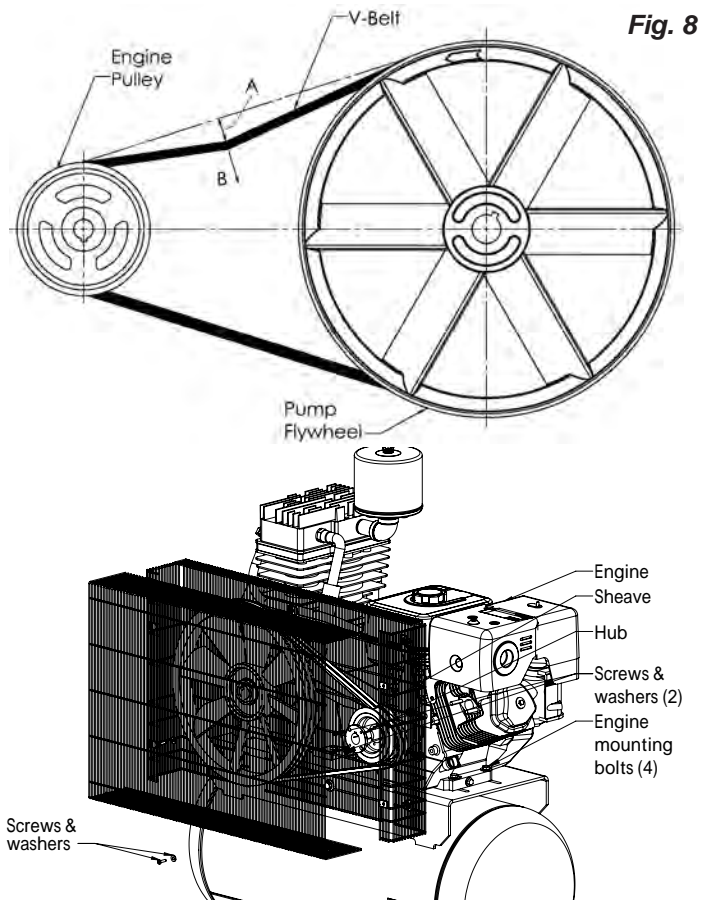

Fig. 8

PULLEY ALIGNMENT

NOTE: Drive belt tensioning and pulley alignment are done at the same time. They are discussed separately for clarity.

⚠ WARNING: To avoid personal injury, always shut off the gasoline engine and relieve all air pressure from the system before performing any service on the air compressor. Do not use the unit with the shrouds or belt guard removed. Serious injury could occur from contact with moving parts.

NOTE: Once the engine pulley has been moved from its factory set location, the grooves of the flywheel and pulley must be aligned to within 1/16" to prevent excessive belt wear.

MAINTENANCE

To check pulley alignment, remove the belt guard and place a straightedge (see **A**) against the pump flywheel (see **B**) (See **Fig. 9**). Measure and record the distance from the straightedge to the edge of the drive belt at point C. Then measure the distance from the straightedge to the edge of the drive belt again at points D and E. Both distances should be the same as at point C. If D or E are different from C, there is a misalignment which must be corrected before the compressor is run. To correct a pulley misalignment, use the following procedure.

1. Remove the front of the belt guard by removing the screws and washers using a Torx T25 bit.
2. Loosen the engine mounting bolts.
3. Remove the 2 screws and lock washers from the hub using a 7/16" wrench.
4. Insert the screws into the threaded holes on the hub and tighten to pull hub away from sheave, remove screws.
5. Align the engine pulley with the pump flywheel (C-D-E must be equal).
6. Replace hub by aligning non-threaded holes in hub to holes in sheave. Insert screws and lock washers and tighten.
7. Adjust the proper belt tension.
8. Retighten the engine mounting bolts to 130-180 in.-lbs.
9. Reinstall the belt guard. All moving parts must be guarded.

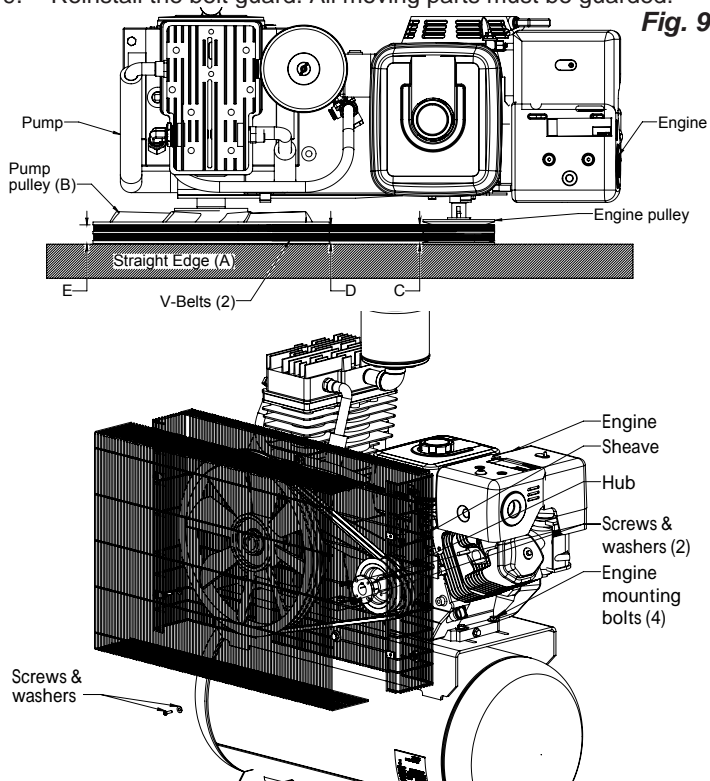

DRIVE BELT REPLACEMENT

WARNING: To avoid personal injury, always shut off the gasoline engine and relieve all air pressure from the system before performing any service on the air compressor. Do not use the unit with the shrouds or belt guard removed. Serious injury could occur from contact with moving parts.

1. Remove the front of the belt guard by removing the screws and washers using a Torx T25 bit.
2. Loosen the engine mounting bolts.

3. Shift the engine towards the pump to the point where the belts can be easily removed and installed.
4. Remove and replace belts. NOTE: The belts must be centered over the grooves on the flywheel and motor pulley.
5. Shift the engine back to the point where the correct deflection exists (see "Drive Belt Tension Adjustment").
6. Retighten the engine mounting bolts to 130-180 in.-lbs.
7. Check to ensure that the tension remained correct.
8. Reinstall the belt guard. All moving parts must be guarded.

TO REPLACE OR CLEAN CHECK VALVE

WARNING: To avoid personal injury, always shut off the gasoline engine and relieve all air pressure from the system before performing any service on the air compressor. Do not use the unit with the shrouds or belt guard removed. Serious injury could occur from contact with moving parts.

1. Shut OFF the gas engine. Relieve all the air pressure from the tank (refer to "Shutdown" in Operating Instructions). Make sure the compressor has cooled down before servicing.
2. Using the appropriately sized wrench, loosen the compression nuts (A) on the check valve (B) and pump head (C). Remove the transfer tube (D).

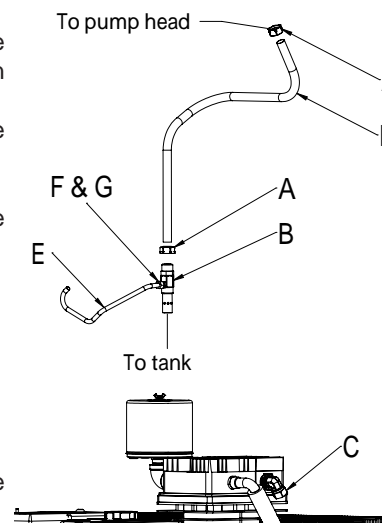

3. Using the appropriately sized wrench, loosen the compression nut (F) from the connector (G), located on the side of the check valve. Remove the bleeder tube (E).
4. Making note of the orientation for reassembly, unscrew the check valve from the tank (counterclockwise) using the appropriately sized wrench.
5. Using a pencil or screwdriver, carefully push the valve disc up and down. If the valve disc does not move freely up and down, the check valve needs to be cleaned or replaced.
6. Clean the check valve with warm soapy water and make sure to dry thoroughly before reinstalling. If the disc valve still does not move freely up and down, it will need to be replaced.
7. Apply thread sealant to the check valve threads and reinstall into the tank by turning clockwise. Make sure it is the same orientation as when it was removed.
8. Replace the bleeder tube and tighten compression nut.
9. Replace the transfer tube and tighten compression nuts.
10. Perform the "Break-in of the pump" procedure in the Operating Instructions to make sure there are no leaks and the check valve is working properly.

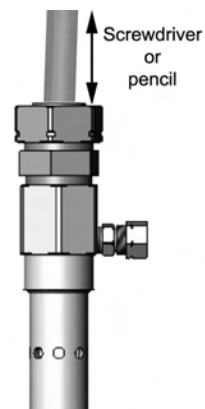

MAINTENANCE

CLEANING THE AIR FILTERS

A dirty air filter will reduce the compressor's performance and life. To avoid any internal contamination of the pump, the filters should be cleaned frequently, and replaced on a regular basis. Felt filters should be cleaned in warm, soapy water, rinsed, and allowed to air dry before reinstallation. Paper filters should be replaced when dirty. Do not allow the filters to become filled with dirt or paint. If the filter becomes filled with paint, it should be replaced. Direct exposure to dirty conditions or painting areas will void your warranty.

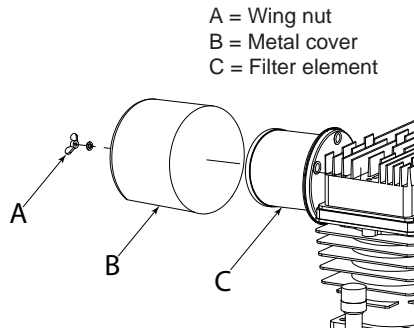

of the suspected leak with a spray bottle. If bubbles appear, repair or replace the faulty component. Do not over tighten any connections.

STORAGE

Before storing the compressor for a prolonged period, use an air blow gun to clean all dust and debris from the compressor. Pull the tank safety valve to release all pressure from the tank. Drain all moisture from the tank. Clean the filter elements and filter housings; replace the elements if necessary. Drain the oil from the pump crankcase and replace it with new oil. Cover the entire unit to protect it from moisture and dust.

CHECKING THE RELIEF VALVE

Pull the tank safety valve daily to ensure that it is operating properly and to clear the valve of any possible obstructions.

TESTING FOR LEAKS

Check that all connections are tight. A small leak in any of the hoses, transfer tubes, or pipe connections will substantially reduce the performance of your air compressor. If you suspect a leak, spray a small amount of soapy water around the area

SERVICE INTERVAL

	Daily or after each use	Every 200 operating hours	Every 250 operating hours	After first 8 hours and then every 100 operating hours
Perform the following maintenance at the intervals indicated below.				
Inspect air filters (clean or replace as necessary)	●			
Check pump oil level	●			
Check engine oil level	●			
Change pump oil (<i>Use synthetic blend, nondetergent air compressor oil.</i>)		●		
Change engine oil (<i>see ENGINE MANUAL (supplied)</i>)				
Operate the tank safety valve	●			
Check belt tension			●	
Drain tank	●			
Check and tighten all bolts (<i>do not over tighten</i>)				●
Gasoline engine maintenance (<i>see ENGINE MANUAL (supplied)</i>)				

TROUBLESHOOTING

Note: Troubleshooting problems may have similar causes and solutions.

PROBLEM	POSSIBLE CAUSE	SOLUTION
Low discharge pressure	Air leaks	Tighten or replace leaking fittings or connections. Do not overtighten.
	Leaking valves	Contact a qualified service center.
	Restricted air intake	Clean or replace air filter element(s).
	Blown gaskets	Contact a qualified service center.
	Worn piston rings or cylinder	Contact a qualified service center.
Compressor pump knocking	Loose motor pulley or pump flywheel	Retighten pulley and flywheel. Check alignment.
	Low oil level in pump crankcase	Keep oil at proper level at all times.
	Excess carbon on valves or top of piston	Contact a qualified service center.
Oil in discharge air	Worn piston rings or cylinder	Contact a qualified service center.
	Restricted air intake	Clean or replace the air filter element(s).
	Oil level too high	Reduce to proper level. Use synthetic blend, non-detergent air compressor oil.
Overheating	Poor ventilation	Relocate compressor to an area with cool, dry, well circulated air, at least 12 in. from nearest wall.
	Dirty cooling surfaces	Clean all cooling surfaces thoroughly.
	Restricted air passages	Inspect and replace transfer tubes and/or the unloader
Excessive belt wear	Pulley out of alignment	Realign pulley with compressor flywheel.
	Improper belt tension	Readjust.
	Pulley wobbles	Replace the pulley and check for a damaged crankshaft or flywheel.
Excessive Unloader Cycling	Air leaks in piping	Tighten or replace leaking fittings or connections. Do not overtighten.
Gasoline Engine Stall	Air leaks in piping	Tighten or replace leaking fittings or connections. Do not overtighten.
Compressor won't start in cold temperatures	Compressor not winterized	See cold weather preparation.
	Engine flooded	Remove spark plug and dry it. Reinstall.
	Compressor too cold	Move compressor to a warmer location.
Air leaking through bleeder valve after compressor shuts off	Dirty or defective check valve.	Replace or clean the check valve (see "To replace or clean check valve" in the maintenance section).

PARTS AND SERVICE

Replacement parts and service are available from your nearest authorized Service Center. If the need arises, contact Product Service as listed at right.

When consulting with a Service Center or Product Service, refer to the model number and serial number located on the serial label of the compressor. Proof of purchase is required for all transactions and a copy of your sales receipt may be requested.

Record the model number, serial number, and date purchased in the spaces provided below. Retain your sales

Model No.

Serial No.

Date Purchased, la date d'achat, la fecha de compra

receipt and this manual for future reference. When needing service, please contact the nearest authorized Service Center or call:

PRODUCT SERVICE



In U.S.A. or Canada

Toll-Free

Fax

1-888-895-4549

1-507-723-5013

PIÈCES ET RÉPARATIONS

Pour pièces de rechange et réparations de votre Centre d'Entretien autorisé le plus proche. Au besoin, veuillez contacter le service après-vente (Product Service) au numéro de téléphone ou à droite.

Lorsque vous appelez un Centre d'Entretien ou le service après-vente, veuillez indiquer le numéro de modèle et le numéro de série situé sur la étiquette de série du compresseur. Une preuve d'achat est nécessaire lors de toute transaction et une copie de votre reçu peut être exigée.

Inscrivez la date d'achat au-dessus de, dans les espaces

réservé à cet effet. Conservez votre reçu et ce manuel pour référence ultérieure.

Quand vous avez besoin des services de l'usine, s'il vous plaît contactez au centre d'entretien autorisé le plus proche ou composez simplement le :

SERVICE CLIENTÈ



Au Canada

Appel gratuit

Télécopieur

1-888-895-4549

1-507-723-5013

REPUESTOS Y SERVICIO

Las piezas de repuesto y el servicio están disponibles del Centro de Servicio autorizado más cercano. Consulte con el Servicio al Cliente (Product Service) listado debajo, si surge la necesidad.

Refiérase al número de modelo y el número de serie situado en la etiqueta de serie del compresor, cuando consulte con un Centro de Servicio o el Servicio al Cliente. Se requiere la prueba de compra para todas las transacciones y puede requerirse una copia de su recibo de venta.

En los espacios provisto arriba registre la fecha de

compra. Guarde su recibo de venta y este manual para referencia futura.

Cuando necesite servicio por favor de consultar el centro de servicio autorizado más cercano o notificar por correo a:

Product Service

Sanborn Mfg., Division of MAT Industries, LLC.

118 West Rock Street

Springfield, MN 56087 EE.UU.

Made in USA with domestic and foreign components
Fabriqué aux États – Unis à l'aide de composants de l'intérieur et de l'étranger
Hecho en EE.UU. con componentes domésticos y extranjeros

©2014 Sanborn Mfg.
A Division of MAT Industries, LLC.
Springfield, MN 56087

1-888-895-4549

All Rights Reserved. Tous droits réservés. Reservados todos los derechos.