

Hardware Information Sheet No. 00001

Dock Wheel Installation

Adding wheels to a new or existing dock doesn't need to be complicated. By using Dock Edge hardware, wheels can be attached simply and securely. The strongest connection needs to be between the dock and the wheel assembly—this is where the most stress occurs. To add wheels to a dock, substitute a standard **Corner Plate (92-104-F)** with a **Corner Leg Holder (86-100-F)** to hold a **Galvalume Leg Pipe (93-168-F/93-110-F)**. This Leg Pipe becomes the strut that will later hold the axle. To provide additional insurance that the Leg Pipe won't move vertically, sandwich a standard Corner Plate between the Corner Leg Holder and the wood dock frame. Rotate the Corner Plate 90° so that it covers the top of the Leg Pipe. To further increase the lateral strength of the Leg Pipe add a **Corner Leg Brace Holder (93-105-F/87-107-F)** and an arm from the **Leg Brace Set (87-101-F)** to the Leg Pipe. Bolt the other end of the arm from the Leg Brace Set to the wood dock frame. Repeat this procedure for the other side of the dock.

Wheel Strut Attachment Detail For Floating Docks

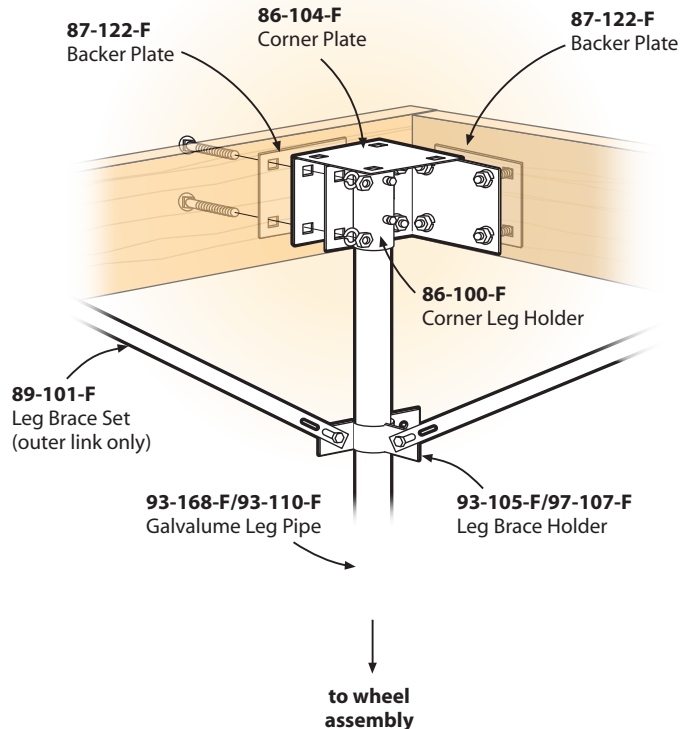

Axle Hardware Configuration For Stationary & Floating Docks

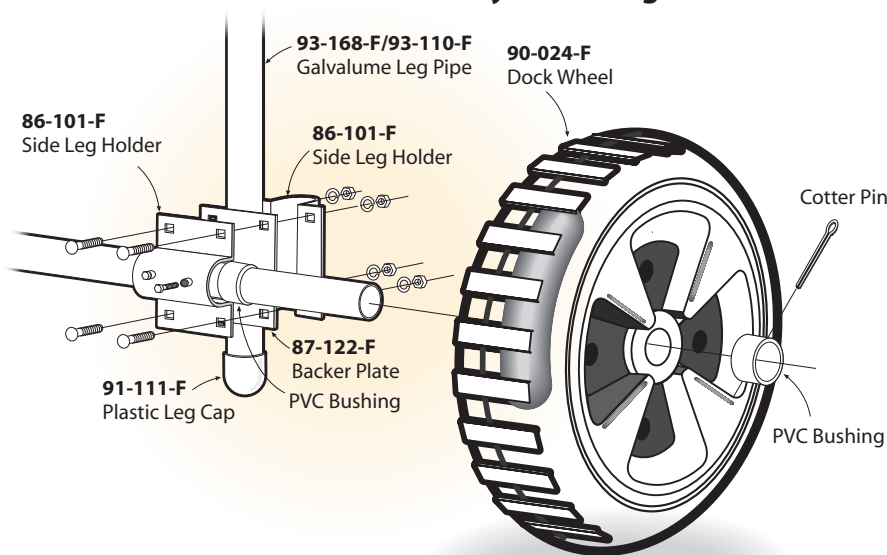

Axle and wheel assembly:

Once the Leg Pipes are securely fastened to the wood dock frame, attach the axle pipe horizontally between the two leg pipes using a combination of **Side Leg Holders (86-101-F)** and **Backer Plates (87-122-F)**. Cut a short section of PVC pipe and slide over the axle to act as a bushing between the Dock Wheel and the Side Leg Holders. Next, drill two holes on either side of the axle end to accept a cotter pin. Slide the **Dock Wheel (90-024-F)** onto the axle followed by another PVC bushing. Install a cotter pin to secure the wheel. Repeat the procedure for each dock wheel.