

10 x 10 SWIM FLOAT

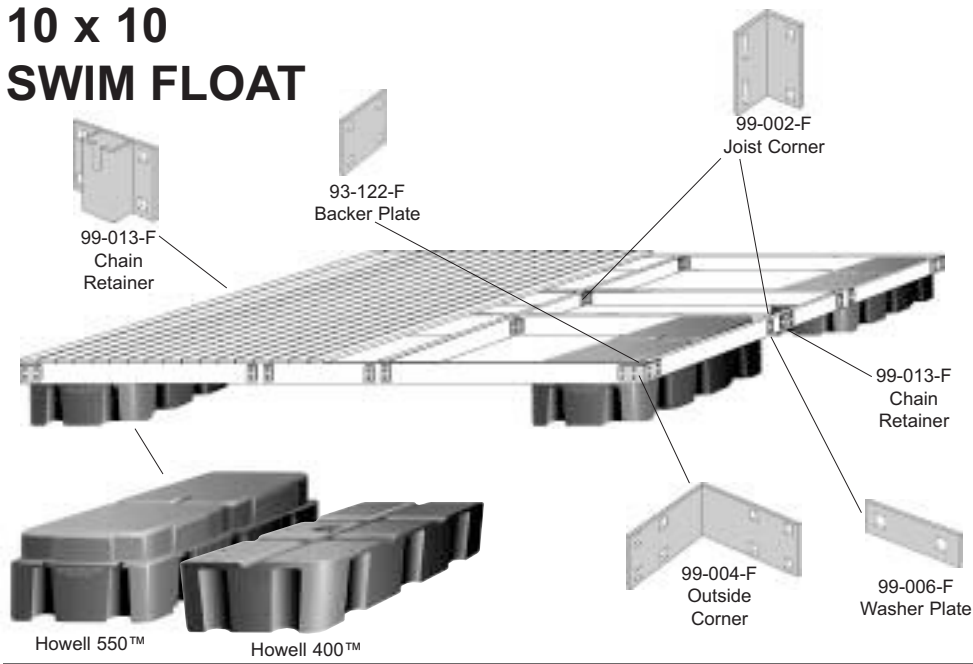

DOCK HARDWARE REQUIRED

Description	QTY
99-004-F Outside Corner	4
99-002-F Joist Corner	24
99-006-F Washer Plate	16
99-013-F Chain Retainer	2
93-122-F Backer Plate	8
99-246-F Howell 550 Float	4
OR	
99-242-F Howell 400 Float	6
1/2" x 2 1/2" Carriage Bolts and nuts	116 each
3/8" x 2" Lag Bolts	32

Note: The Howell 550 has a recessed flange whereas the Howell 400 has traditional top flange mount.

See rear cover for sample optional hardware placement for corners and hinges and formulae for the recommended number of floats to use for your dock project as well as an **IMPORTANT** note from DockEdge+.

8 x 20 MAIN DOCK

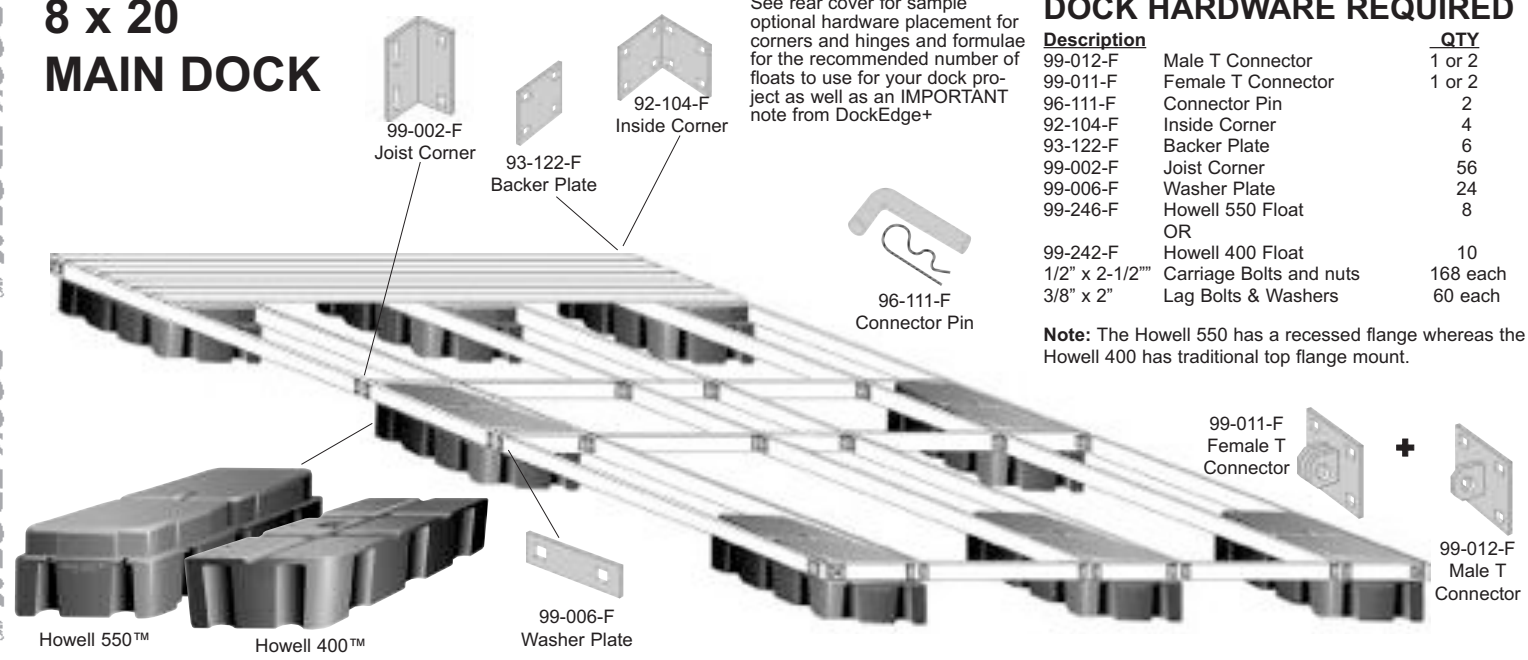

DOCK HARDWARE REQUIRED

Description	QTY
99-012-F Male T Connector	1 or 2
99-011-F Female T Connector	1 or 2
96-111-F Connector Pin	2
92-104-F Inside Corner	4
93-122-F Backer Plate	6
99-002-F Joist Corner	56
99-006-F Washer Plate	24
99-246-F Howell 550 Float	8
OR	
99-242-F Howell 400 Float	10
1/2" x 2-1/2" Carriage Bolts and nuts	168 each
3/8" x 2" Lag Bolts & Washers	60 each

Note: The Howell 550 has a recessed flange whereas the Howell 400 has traditional top flange mount.

12 x 12 SWIM FLOAT

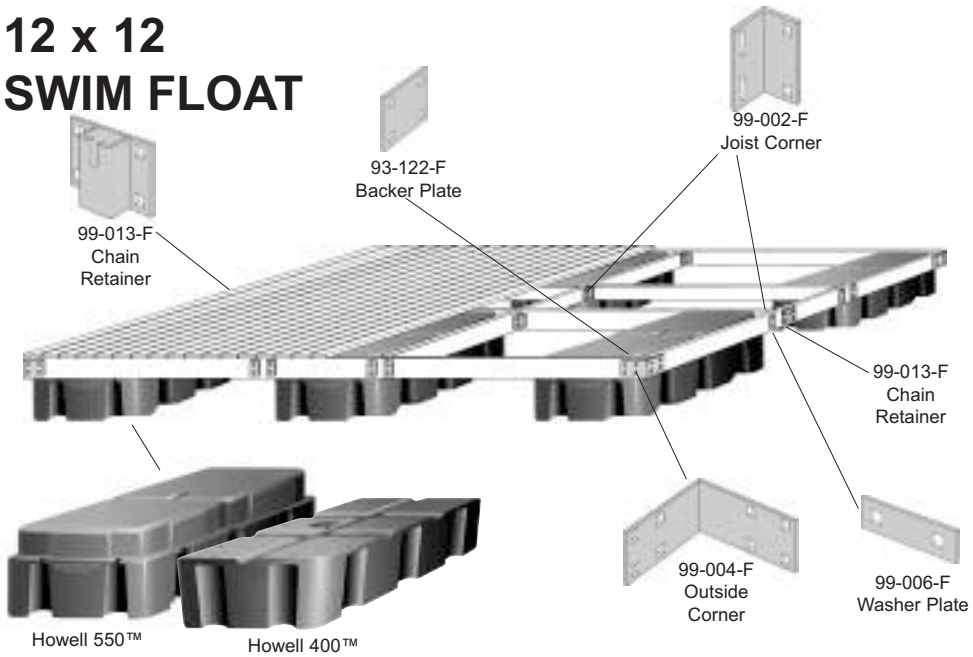

DOCK HARDWARE REQUIRED

Description	QTY
99-004-F Outside Corner	4
99-002-F Joist Corner	24
99-006-F Washer Plate	16
99-013-F Chain Retainer	2
93-122-F Backer Plate	8
99-246-F Howell 550 Float	6
OR	
99-242-F Howell 400 Float	8
1/2" x 2 1/2" Carriage Bolts and nuts	116 each
3/8" x 2" Lag Bolts	48

Note: The Howell 550 has a recessed flange whereas the Howell 400 has traditional top flange mount.

See rear cover for sample optional hardware placement for corners and hinges and formulae for the recommended number of floats to use for your dock project as well as an **IMPORTANT** note from DockEdge+.

10 x 20 MAIN DOCK

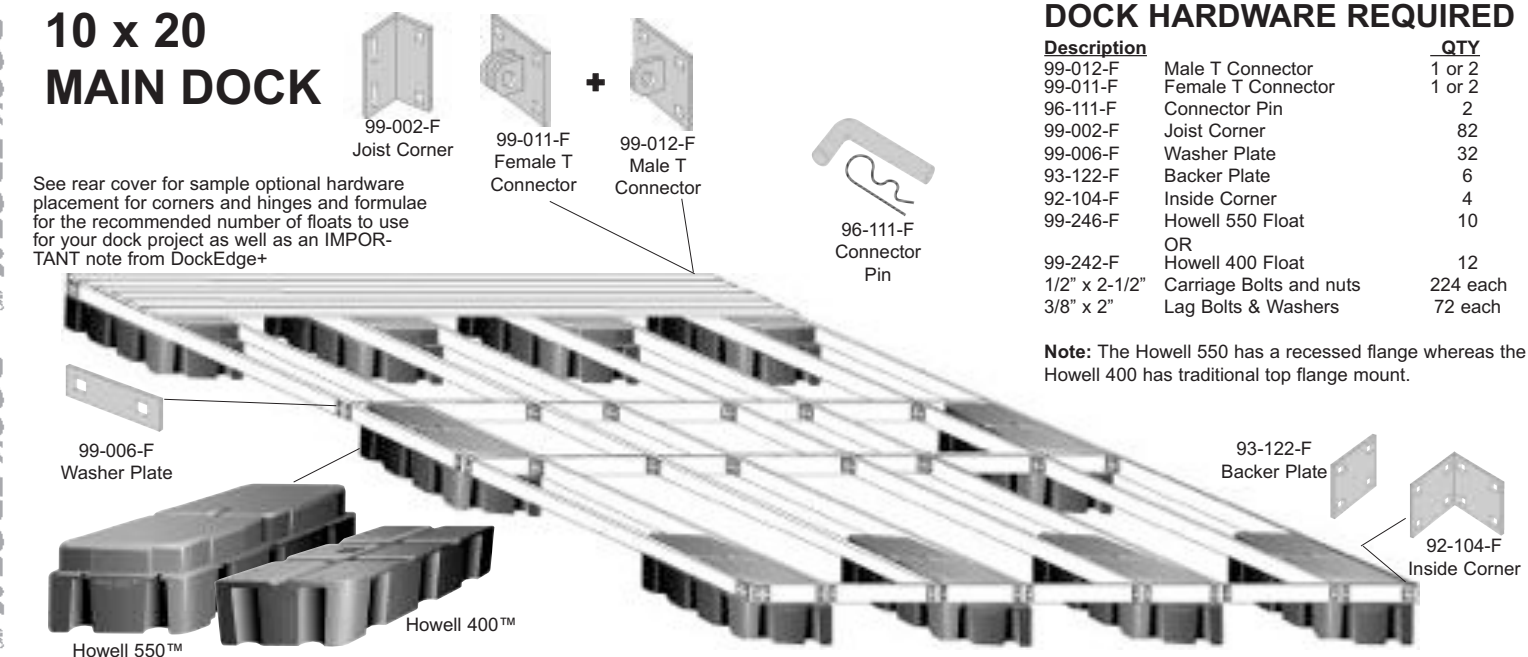

DOCK HARDWARE REQUIRED

Description	QTY
99-012-F Male T Connector	1 or 2
99-011-F Female T Connector	1 or 2
96-111-F Connector Pin	2
99-002-F Joist Corner	82
99-006-F Washer Plate	32
93-122-F Backer Plate	6
92-104-F Inside Corner	4
99-246-F Howell 550 Float	10
OR	
99-242-F Howell 400 Float	12
1/2" x 2-1/2" Carriage Bolts and nuts	224 each
3/8" x 2" Lag Bolts & Washers	72 each

Note: The Howell 550 has a recessed flange whereas the Howell 400 has traditional top flange mount.

6 x 20 MAIN DOCK

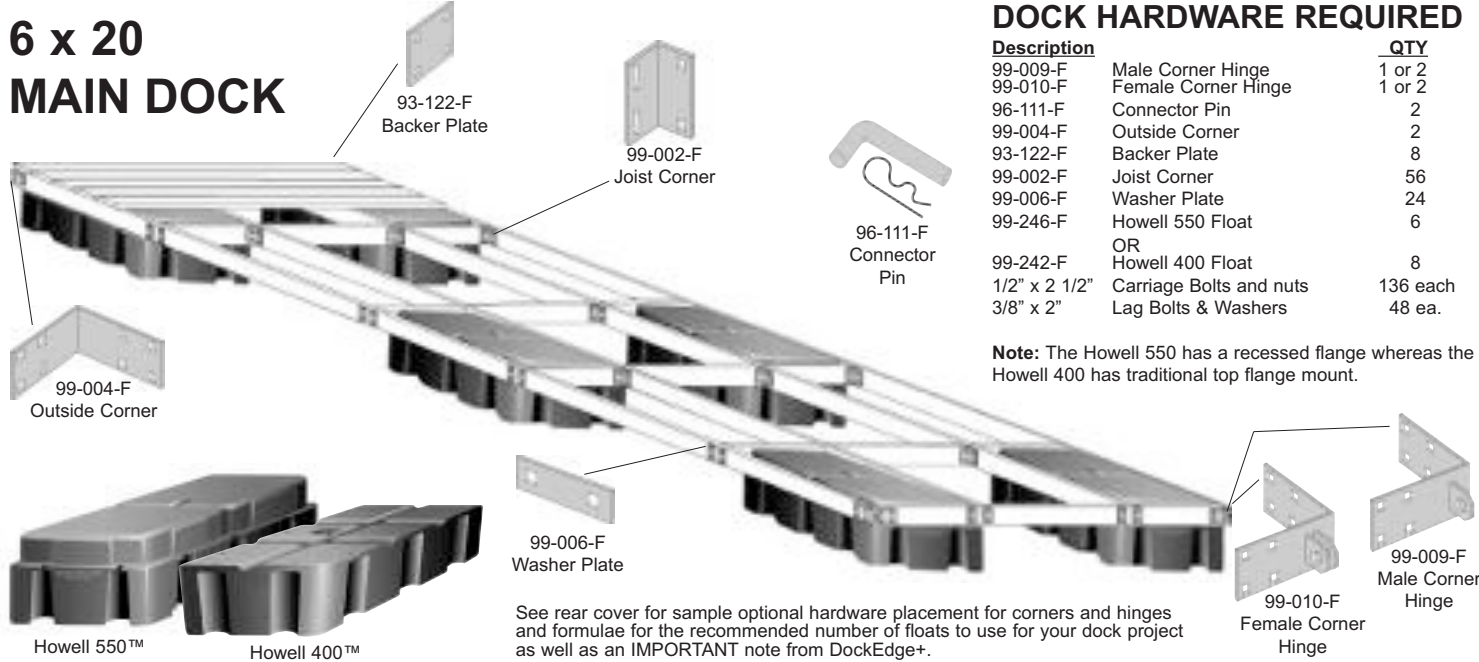

DOCK HARDWARE REQUIRED

Description	QTY
99-009-F Male Corner Hinge	1 or 2
99-010-F Female Corner Hinge	1 or 2
96-111-F Connector Pin	2
99-004-F Outside Corner	2
93-122-F Backer Plate	8
99-002-F Joist Corner	56
99-006-F Washer Plate	24
99-246-F Howell 550 Float	6
OR	
99-242-F Howell 400 Float	8
1/2" x 2 1/2" Carriage Bolts and nuts	136 each
3/8" x 2" Lag Bolts & Washers	48 ea.

Note: The Howell 550 has a recessed flange whereas the Howell 400 has traditional top flange mount.

See rear cover for sample optional hardware placement for corners and hinges and formulae for the recommended number of floats to use for your dock project as well as an **IMPORTANT** note from DockEdge+.

4 x 20 FINGER DOCK

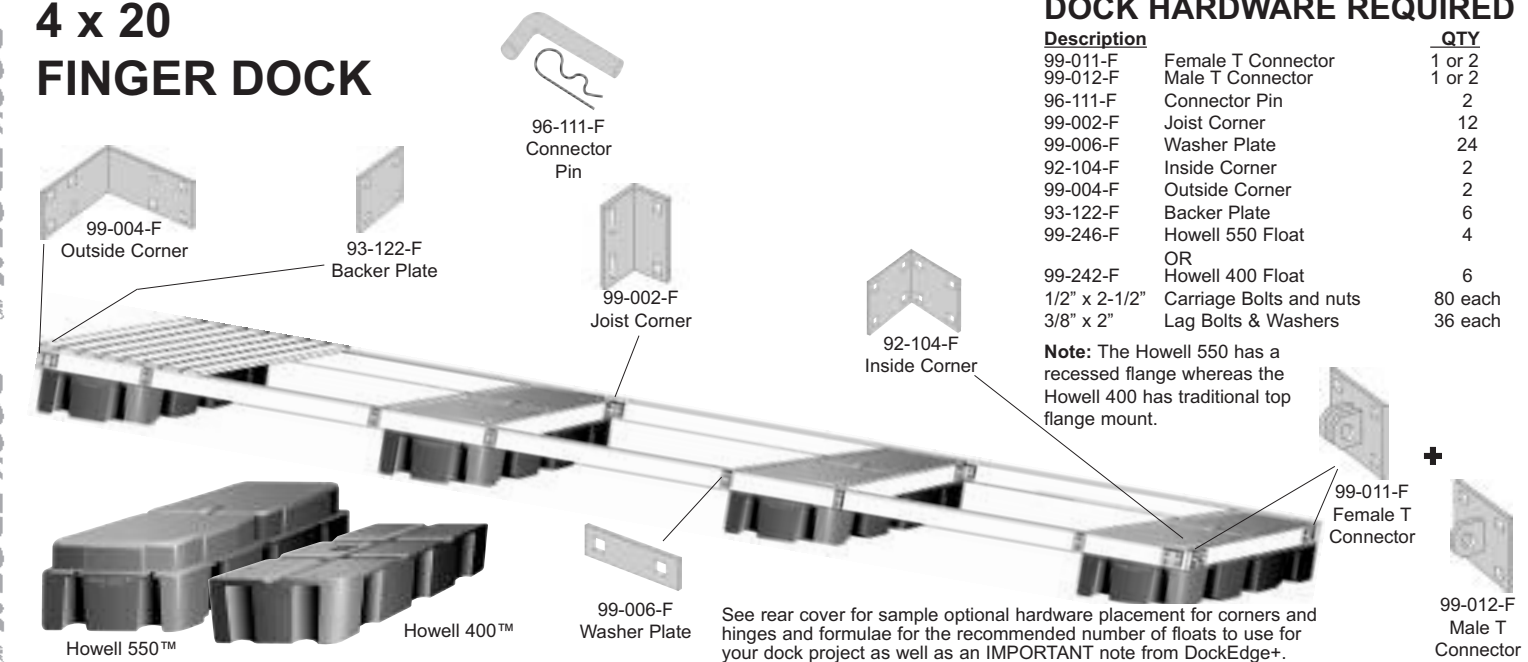

DOCK HARDWARE REQUIRED

Description	QTY
99-011-F Female T Connector	1 or 2
99-012-F Male T Connector	1 or 2
96-111-F Connector Pin	2
99-002-F Joist Corner	12
99-006-F Washer Plate	24
92-104-F Inside Corner	2
99-004-F Outside Corner	2
93-122-F Backer Plate	6
99-246-F Howell 550 Float	4
OR	
99-242-F Howell 400 Float	6
1/2" x 2-1/2" Carriage Bolts and nuts	80 each
3/8" x 2" Lag Bolts & Washers	36 each

Note: The Howell 550 has a recessed flange whereas the Howell 400 has traditional top flange mount.

See rear cover for sample optional hardware placement for corners and hinges and formulae for the recommended number of floats to use for your dock project as well as an **IMPORTANT** note from DockEdge+.

FLOATING DOCK HARDWARE PLACEMENT for CORNERS & HINGES

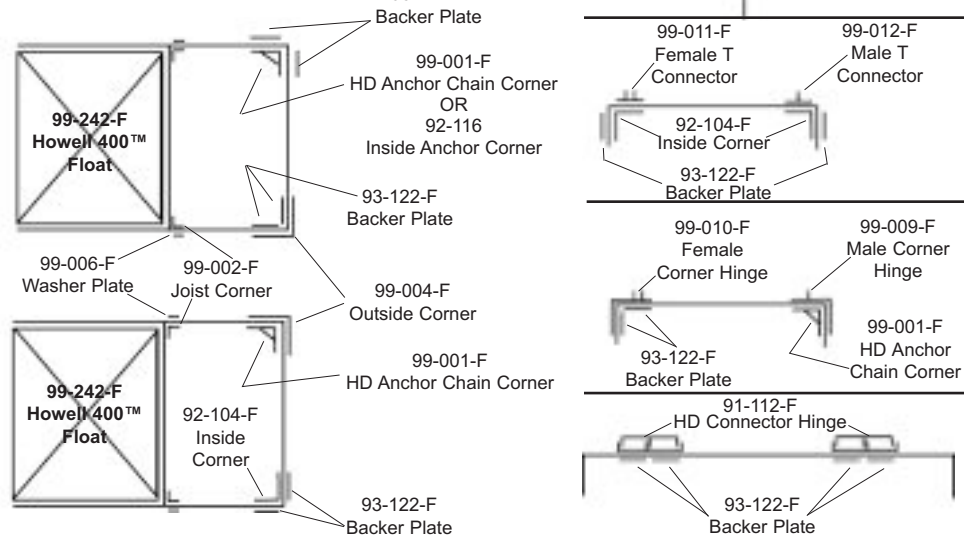

FLOTATION CAPACITY FORMULAE, REQUIRED # OF FLOATS
 Howell 550™: (Square Footage of Dock x 25) / 550= # of Floats
 Howell 400™: (Square Footage of Dock x 25) / 400= # of Floats
 Formulae based on average use of residential dock at 25lb/ ft.²

FLOATING DOCK ANCHORAGE

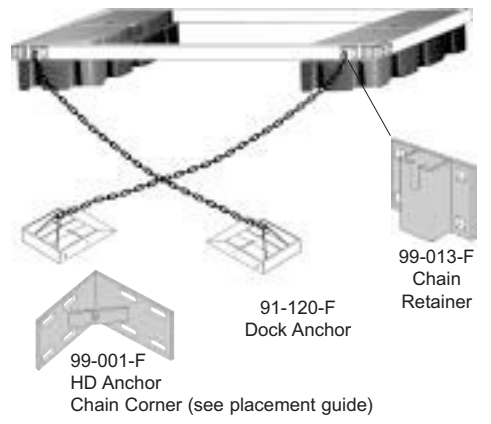

DOCK HARDWARE REQUIRED

Description	QTY
99-013-F Chain Retainer	2
93-122-F Backer Plate	4
OR	
99-001-F HD Anchor Chain Corner	2
99-004-F Outside Corner	2
3/8" x 2-1/2" Carriage Bolts and nuts	16 each
OR	
1/2" x 2 1/2" Carriage Bolts and nuts	16 each
3/8" chain QTY to suit application	
91-120-F Dock Anchor	2

STATIONARY DOCK HARDWARE

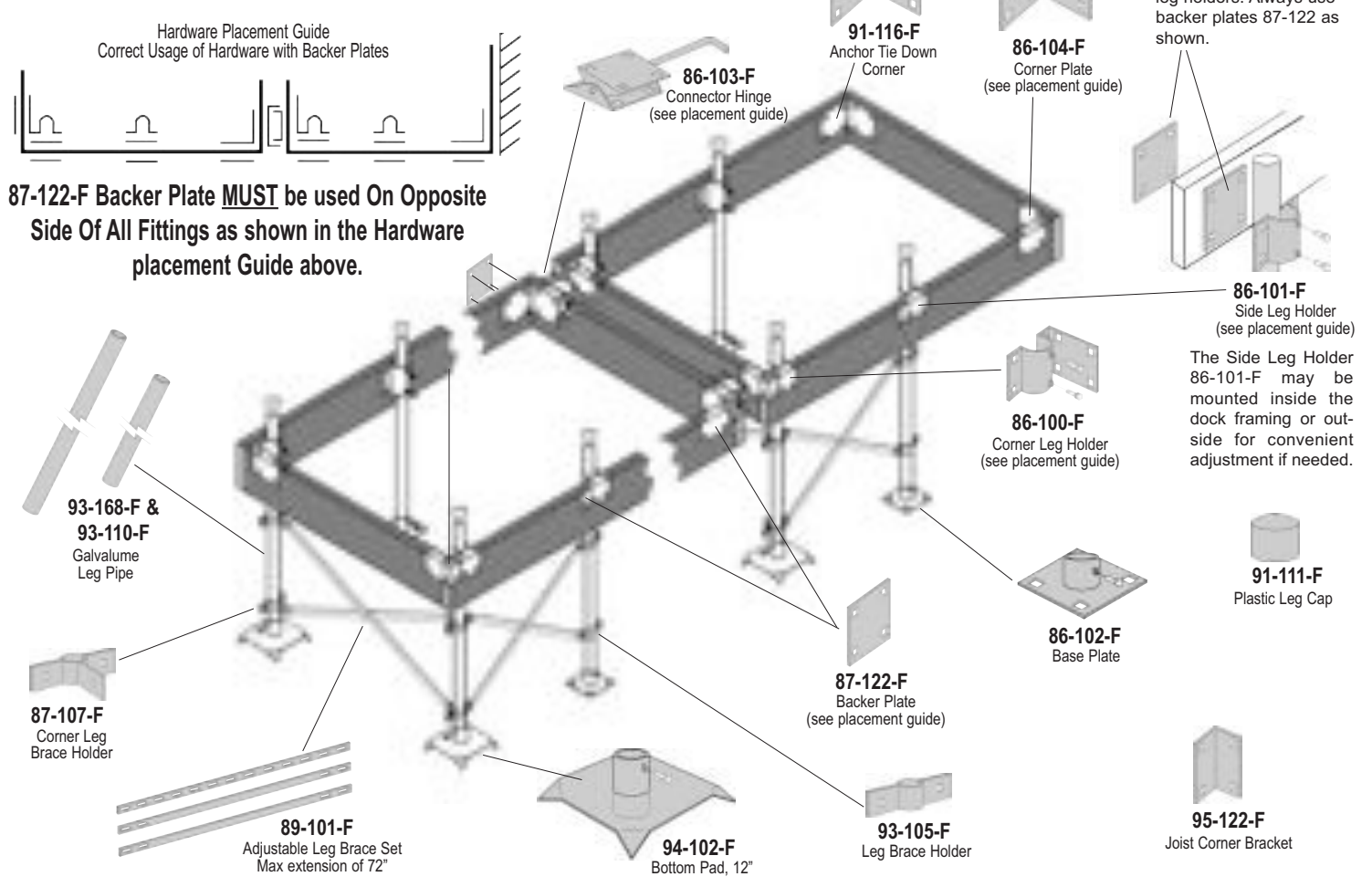

IMPORTANT: DockEdge+ Inc. assumes no responsibility or liability for the accuracy or representation of the graphic illustrations shown in this hardware guide. These graphic illustrations are not intended to be architectural drawings, and are not to be substituted for engineered drawings. Each is intended as a guideline ONLY. DockEdge+ Inc. does not warrant the quantities and/ or bill of materials to be accurate in all uses and applications. Individual dock structures may vary by necessity, preference or design. It may be necessary to vary the amount of materials listed in this guide depending on dock size, material usage, necessity and/ or the severity of the conditions to which the dock structure is subjected to. All graphic illustrations are based on the use of conventional framework of 2" x 6" lumber and decking lumber. Freeboard may be adjusted by using 2"x8" or 2"x10" lumber. Substitutions in lumber and hardware placement may effect floatation.

FLOATING AND STATIONARY DOCK HARDWARE GUIDE

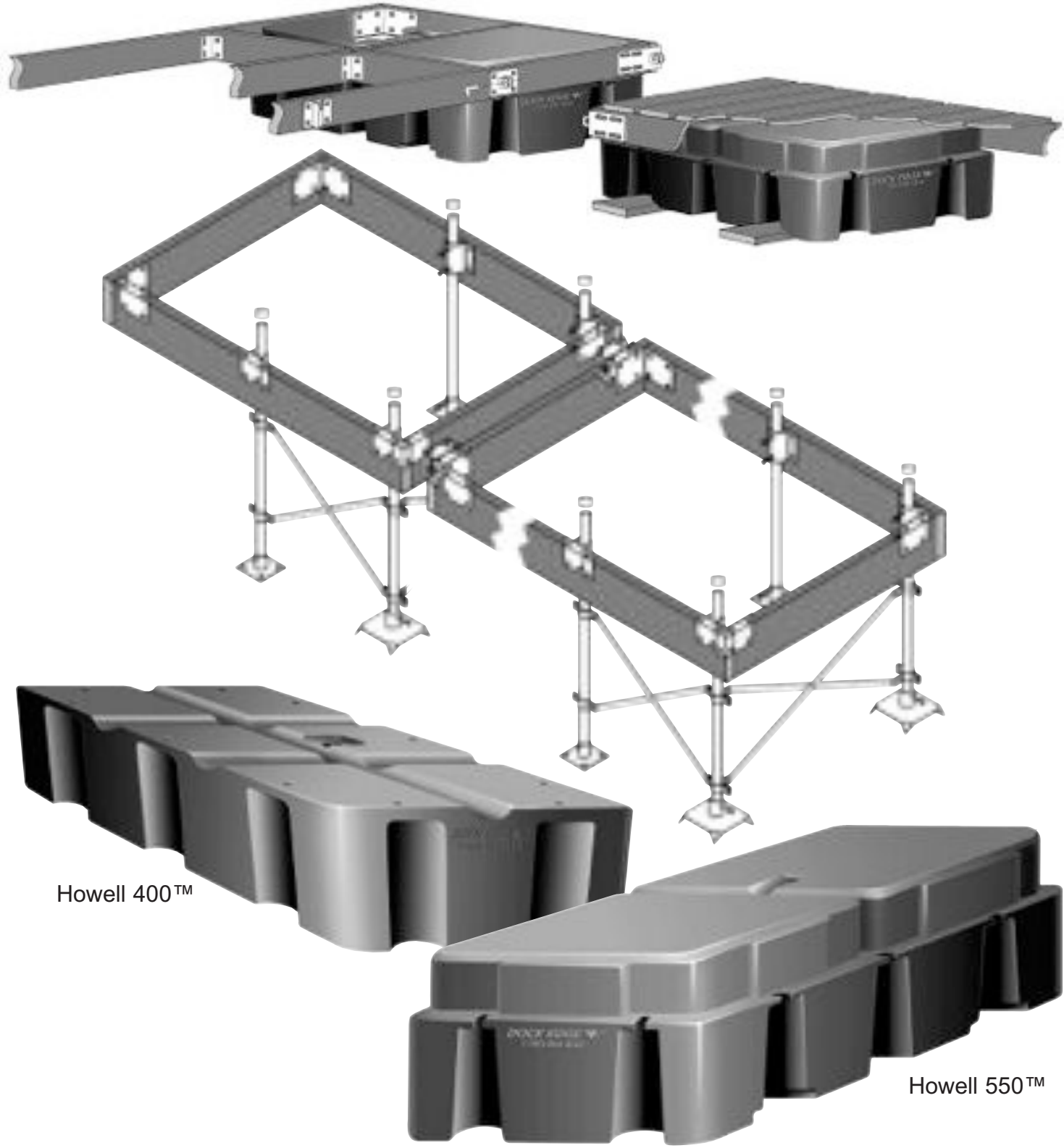

Howell 400™

Howell 550™