

FROZEN DRINK, SLUSH, GRANITA MACHINES



MADE IN ITALY



Models:

GRA122 / GRA123

Standard Features

- Indoor and outdoor use.
- The double mixing system prevents ice accumulation, for optimum product's consistency.
- Cold light illumination with LED.
- Lighted cover.
- Adjustable consistency.
- Safety stop system
- Air cooling system – R404a
- Manual control keypad
- NSF-6 certified safe for milk
- Each Tank can Independently Chill or Freeze

GRA-122



GRA-123



1-year parts and labor warranty (US Only)

ampto.com

FROZEN DRINK, SLUSH, GRANITA MACHINES

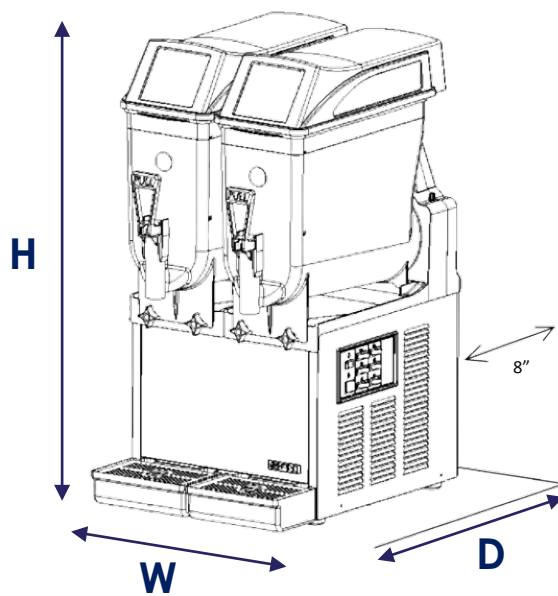

SPECIFICATIONS		
	GRA-122	GRA-123
Bowls	2	3
Bowl Capacity (each)	3.2 Gal / 12 Lts	3.2 Gal / 12 Lts
Total Capacity	6.4 Gal / 24 Lts	9.6 Gal / 36 Lts
Power Supply	110V/60HZ/1ph	110V/60HZ/1ph
Amps	11	14
Plug / Connection	Nema 5-15P	Nema 5-20P
Net Weight (lbs)	117	172
Product Dim. (WxDxH)	15.8" x 21.9" x 32.5"	15.8" x 23.6" x 32.5"
Shipping Weight (lbs)	123	198
Shipping Dim. (WxDxH)	16" x 22" x 33"	25" x 22" x 33"



Notes:

- Operate at room temperature between 75°-90° F (24° and 32°C)
- Clearance of 8" require on all sides
- Mixture must maintain a sugar content between 12 -14%; a lower concentration could seriously damage the mixing parts and gear motors.
- For proper use and optimum durability of moving parts, adequate lubrication must be maintained – RSPM040 Lubricant

GRA-122



Nema 5-15 125 VAC
2 Pole, 3 Wire
Grounding

GRA-123



Nema 5-20 125 VAC
2 Pole, 3 Wire
Grounding

AMPTO is continuously improving products. Specifications are subject to change without notice.