

CONFIDENTIAL

SWAY BRACING IS REQ'D,
REFER TO MANUAL.
HANGER DETAIL SHOWN IS OUR STANDARD
DESIGN AND MAY NOT REPRESENT THE ACTUAL
HANGER DESIGN UTILIZED ON THIS SYSTEM.

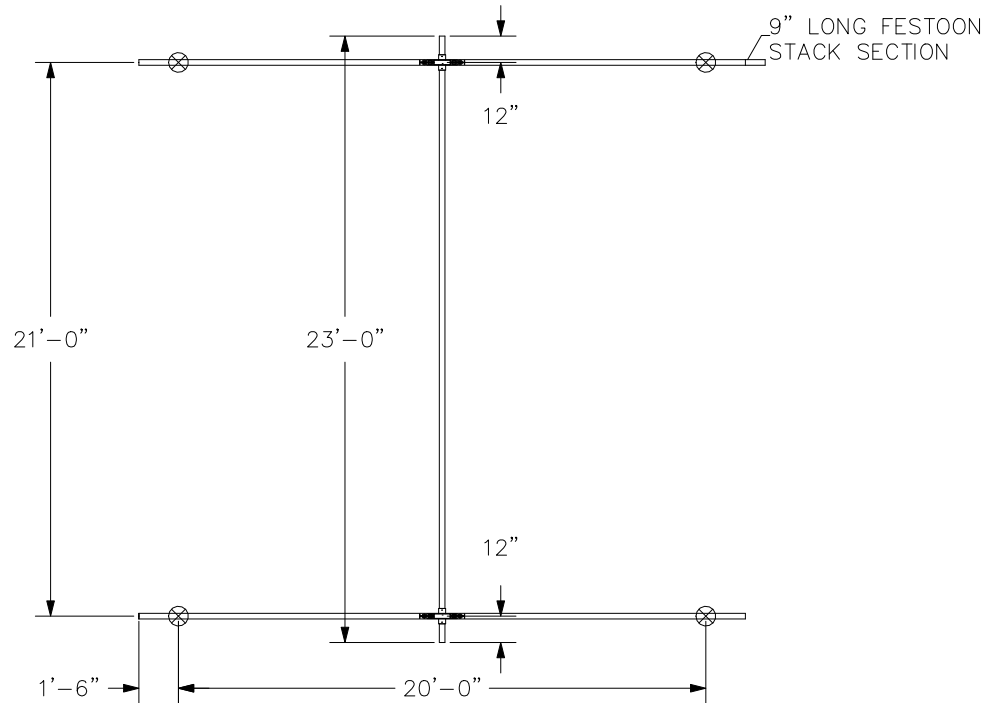

NOTE C: MINIMUM THD ROD DROP MUST MAINTAIN
3" OF CLEARANCE BETWEEN BRIDGE
AND LOWEST OBSTRUCTION.

BRIDGE TROLLEY TRAVEL IS 20'-7".
ENDTRUCK TRAVEL IS 20'-9 7/16".

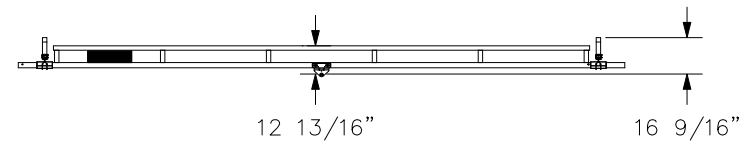
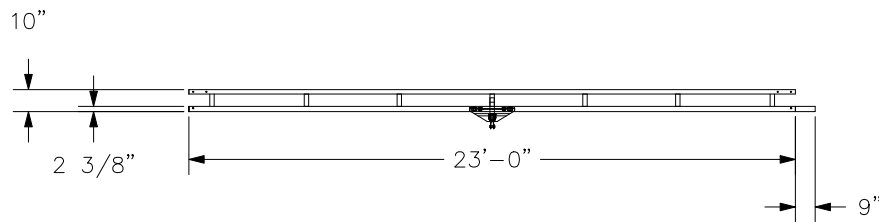

CREATED BY: WISCOLIFT INC

HANGERS ARE ON 20' CENTERS MAXIMUM
WITH A 48" CANTILEVER ON EACH END MAXIMUM.
HANGERS MUST BE WITHIN 48" OF SPLICE JOINT
⊗ = HANGER POINT
DO NOT SCALE FROM DRAWING.
DIMENSIONS ARE STEEL TO STEEL AND MAY VARY.
HANGER POSITION TOLERANCE = ±3 1/2"

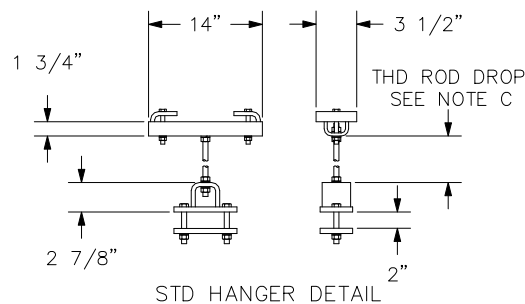

CRANE INFORMATION		GORBEL 600 FISHERS RUN P.O. BOX 593 FISHERS, NY 14453-0593	
CAPACITY: 500LBS/BR			
BRIDGE OAL: 23'-0"		GLCS500-23-23	
BRIDGE SERIES: 500		GENERAL ARRANGEMENT	
RUNWAY OAL: 23'-0"		TOLERANCE: ±1/8	BY: bilcon
RUNWAY SERIES: 500		QUANTITY: 1	DATE: AUG 13, 2015
I.D. #: DEMO500C.3A		LINE #: 3	P/N: DEMO500C.3A