

CONFIDENTIAL

SWAY BRACING IS REQ'D,
REFER TO MANUAL.
HANGER DETAIL SHOWN IS OUR STANDARD
DESIGN AND MAY NOT REPRESENT THE ACTUAL
HANGER DESIGN UTILIZED ON THIS SYSTEM.

NOTE C: MINIMUM THD ROD DROP MUST MAINTAIN
3" OF CLEARANCE BETWEEN BRIDGE
AND LOWEST OBSTRUCTION.

BRIDGE TROLLEY TRAVEL IS 12'-7".
ENDTRUCK TRAVEL IS 40'-9 7/16".

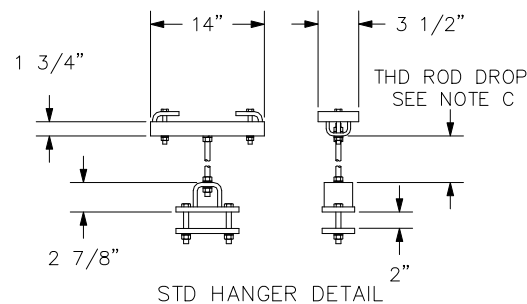
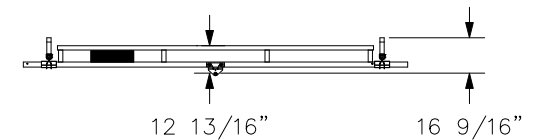
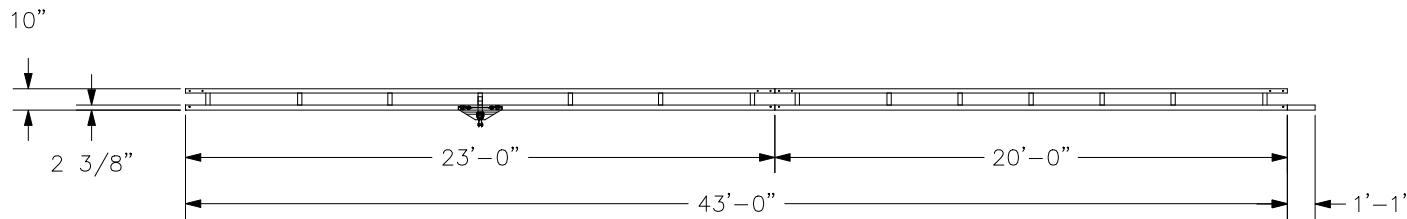
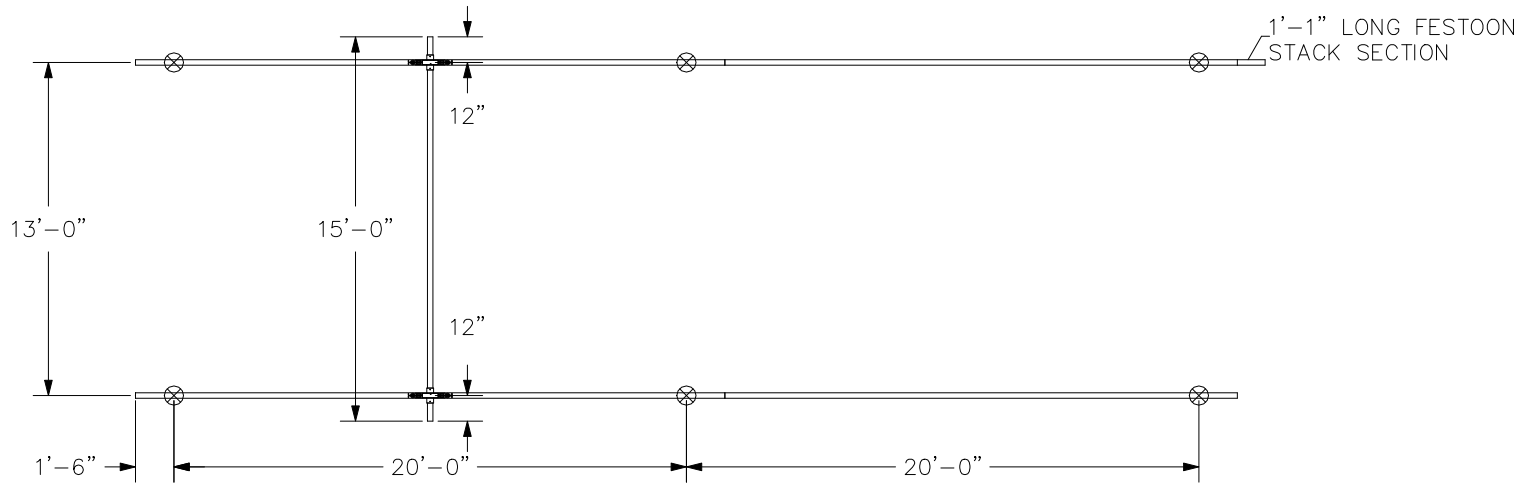

HANGERS ARE ON 20' CENTERS MAXIMUM
WITH A 48" CANTILEVER ON EACH END MAXIMUM.
HANGERS MUST BE WITHIN 48" OF SPLICE JOINT
⊗ = HANGER POINT
DO NOT SCALE FROM DRAWING.
DIMENSIONS ARE STEEL TO STEEL AND MAY VARY.
HANGER POSITION TOLERANCE = ±3 1/2"

CREATED BY: WISCOLIFT INC

CRANE INFORMATION		GORBEL 600 FISHERS RUN P.O. BOX 593 FISHERS, NY 14453-0593	
CAPACITY: 500LBS/BR BRIDGE OAL: 15'-0" BRIDGE SERIES: 500 RUNWAY OAL: 43'-0" RUNWAY SERIES: 500			
TOLERANCE: ±1/8		BY: bilcon	DATE: AUG 13, 2015
QUANTITY: 1		LINE #: 2	P/N: DEMO500C.2A
I.D. #: DEMO500C.2A			