

CONFIDENTIAL

SWAY BRACING IS REQ'D,
REFER TO MANUAL.
HANGER DETAIL SHOWN IS OUR STANDARD
DESIGN AND MAY NOT REPRESENT THE ACTUAL
HANGER DESIGN UTILIZED ON THIS SYSTEM.

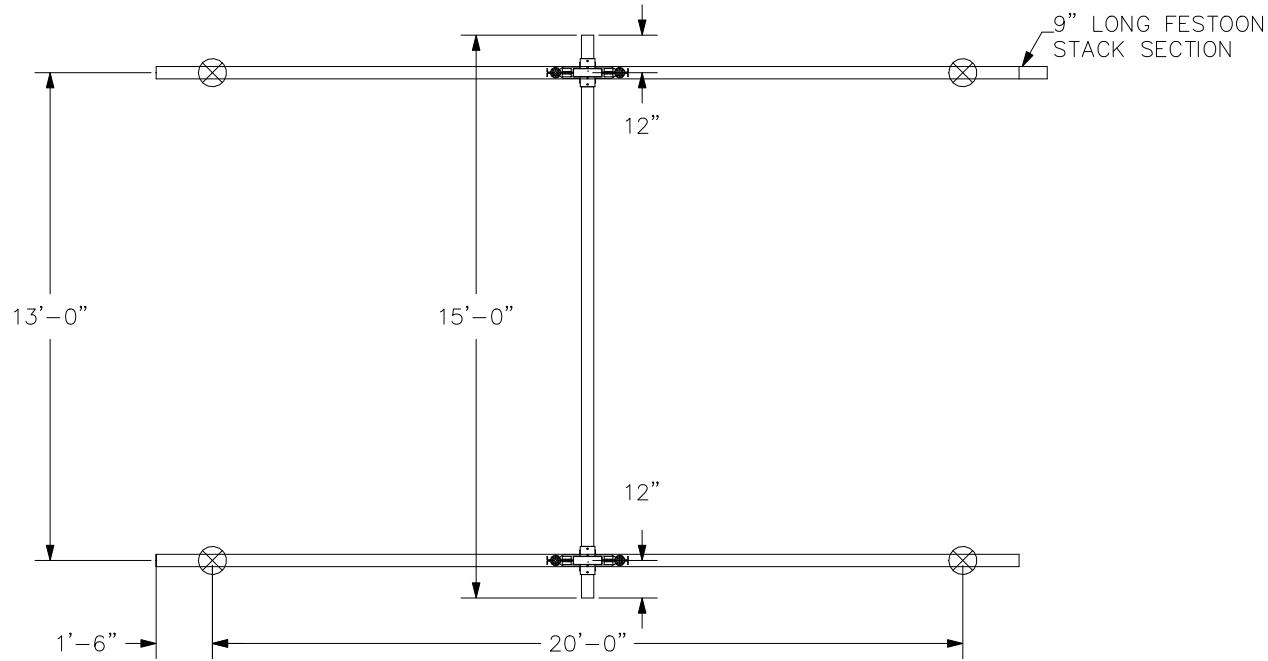

NOTE C: MINIMUM THD ROD DROP MUST MAINTAIN
3" OF CLEARANCE BETWEEN BRIDGE
AND LOWEST OBSTRUCTION.

BRIDGE TROLLEY TRAVEL IS 12'-3 9/16".
ENDTRUCK TRAVEL IS 20'-3 1/2".

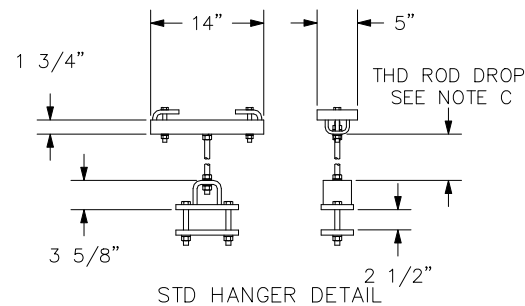
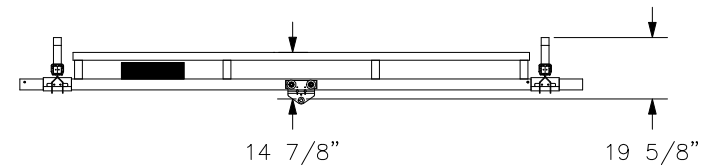
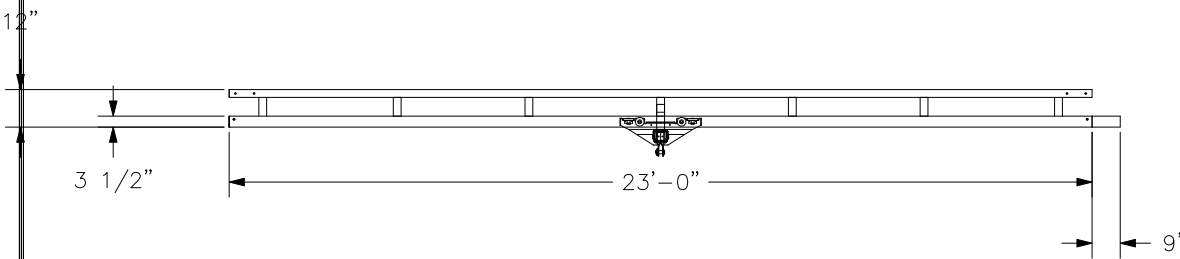

HANGERS ARE ON 20' CENTERS MAXIMUM
WITH A 48" CANTILEVER ON EACH END MAXIMUM.
HANGERS MUST BE WITHIN 48" OF SPLICE JOINT
⊗ = HANGER POINT
DO NOT SCALE FROM DRAWING.
DIMENSIONS ARE STEEL TO STEEL AND MAY VARY.
HANGER POSITION TOLERANCE = ±3 1/2"

CREATED BY: WISCOLIFT INC

CRANE INFORMATION		GORBEL 600 FISHERS RUN P.O. BOX 593 FISHERS, NY 14453-0593		
CAPACITY: 2000LBS/BR BRIDGE OAL: 15'-0" BRIDGE SERIES: 2000 RUNWAY OAL: 23'-0" RUNWAY SERIES: 2000				GLCS2000-15-23
TOLERANCE: ±1/8		BY: bilcon	DATE: AUG 12, 2015	
QUANTITY: 1		LINE #: 1	P/N: DEMO2000C.1A	
I.D. #: DEMO2000C.1A				