

CONFIDENTIAL

SWAY BRACING IS REQ'D,
REFER TO MANUAL.
HANGER DETAIL SHOWN IS OUR STANDARD
DESIGN AND MAY NOT REPRESENT THE ACTUAL
HANGER DESIGN UTILIZED ON THIS SYSTEM.

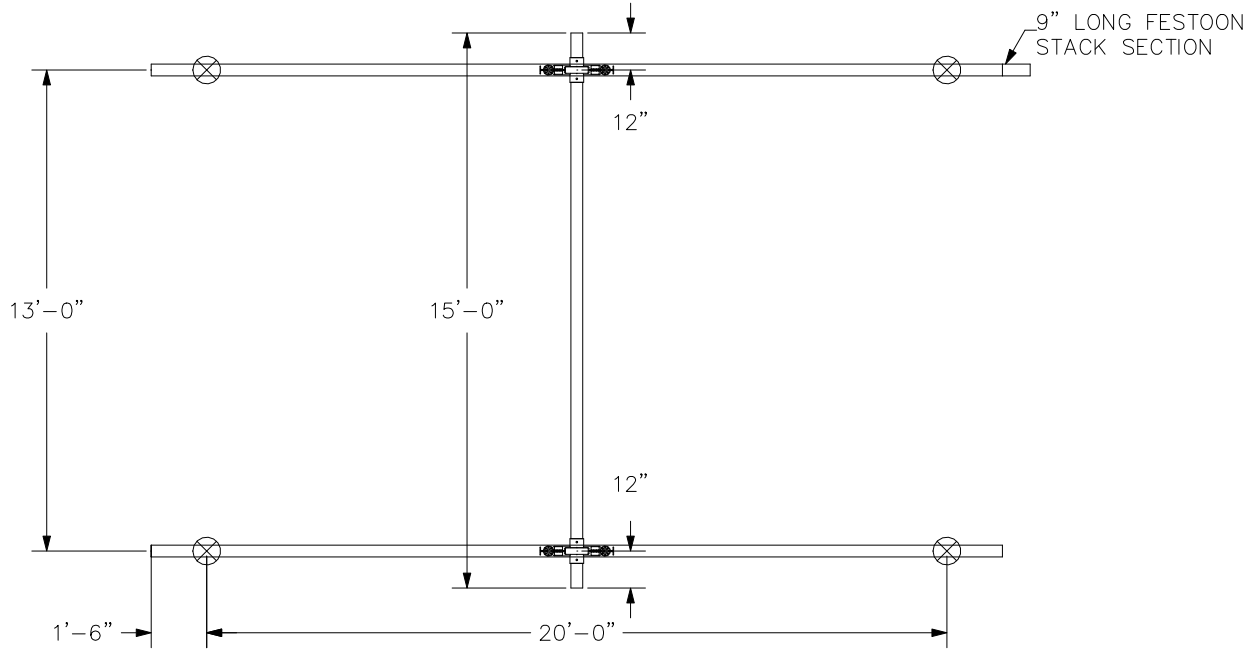

NOTE C: MINIMUM THD ROD DROP MUST MAINTAIN
3" OF CLEARANCE BETWEEN BRIDGE
AND LOWEST OBSTRUCTION.

BRIDGE TROLLEY TRAVEL IS 12'-4 7/16".
ENDTRUCK TRAVEL IS 20'-5 5/8".

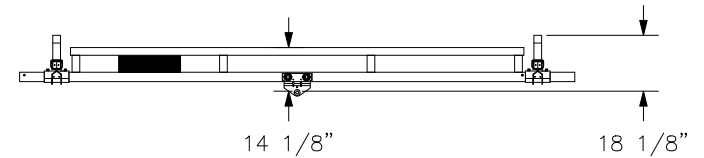
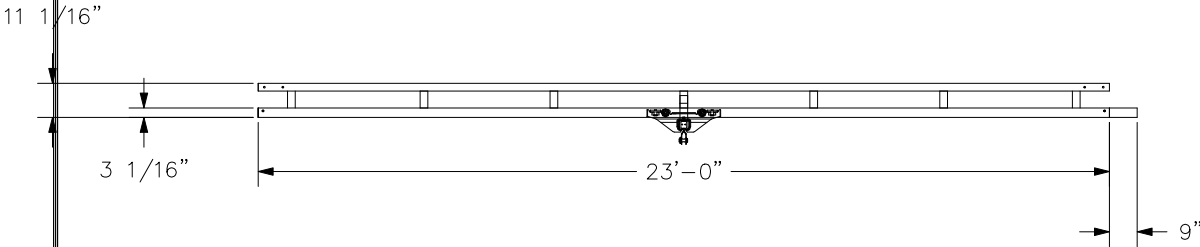

CREATED BY: WISCOLIFT INC

CRANE INFORMATION		GORBEL 600 FISHERS RUN P.O. BOX 593 FISHERS, NY 14453-0593	
CAPACITY: 1000LBS/BR			
BRIDGE OAL: 15'-0"		GLCS1000-15-23	
BRIDGE SERIES: 1000		GENERAL ARRANGEMENT	
RUNWAY OAL: 23'-0"		BY: bilcon	
RUNWAY SERIES: 1000		DATE: AUG 12, 2015	
TOLERANCE: ±1/8		LINE #: 1	
QUANTITY: 1		P/N: DEMO1000C.1A	
I.D. #: DEMO1000C.1A			

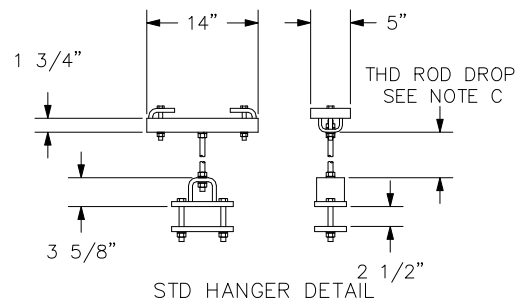

HANGERS ARE ON 20' CENTERS MAXIMUM
WITH A 48" CANTILEVER ON EACH END MAXIMUM.
HANGERS MUST BE WITHIN 48" OF SPLICE JOINT
⊗ = HANGER POINT
DO NOT SCALE FROM DRAWING.
DIMENSIONS ARE STEEL TO STEEL AND MAY VARY.
HANGER POSITION TOLERANCE = ±3 1/2"