

CONFIDENTIAL

SUPPORT ASSEMBLIES ARE DESIGNED TO AISC SPECIFICATIONS. IF NO MOVEMENT OF SUPPORT ASSEMBLIES IS REQUIRED, THEN BRACING TO BUILDING STEEL IS RECOMMENDED (NOT INCLUDED).

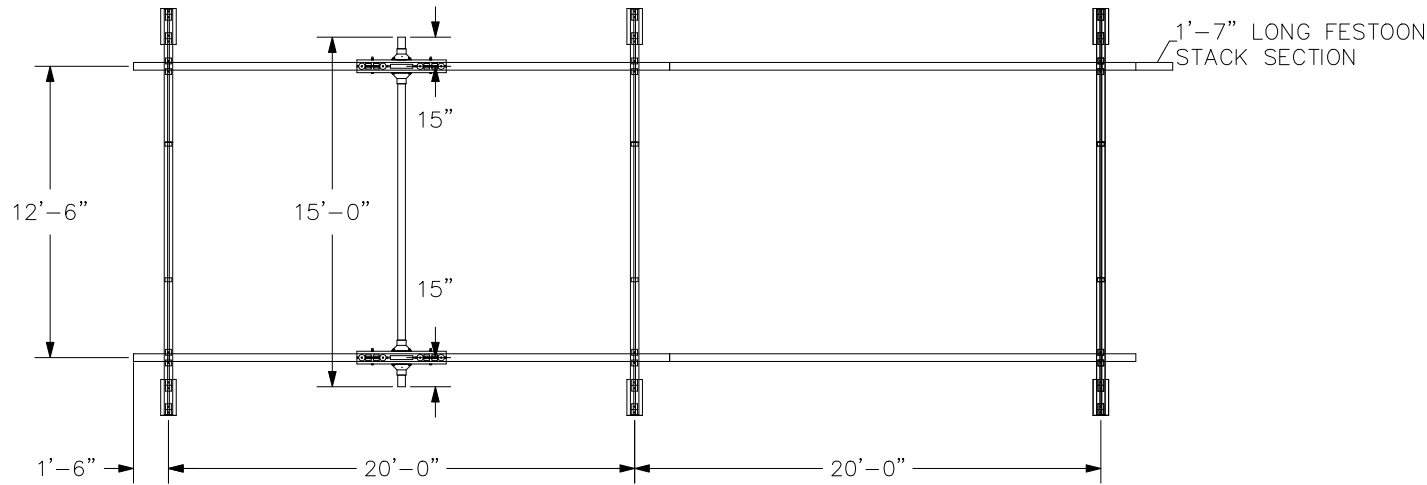

BRIDGE TROLLEY TRAVEL IS 10'-6 1/16".  
ENDTRUCK TRAVEL IS 38'-7 1/2".

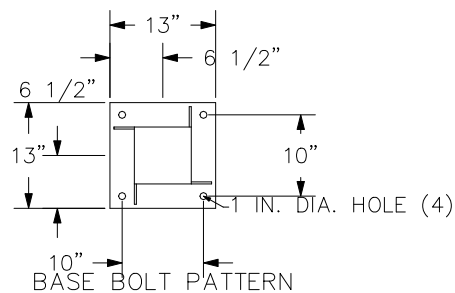
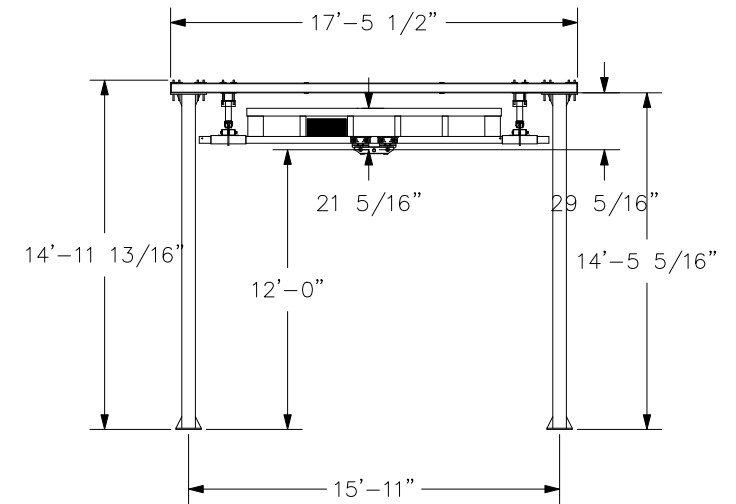
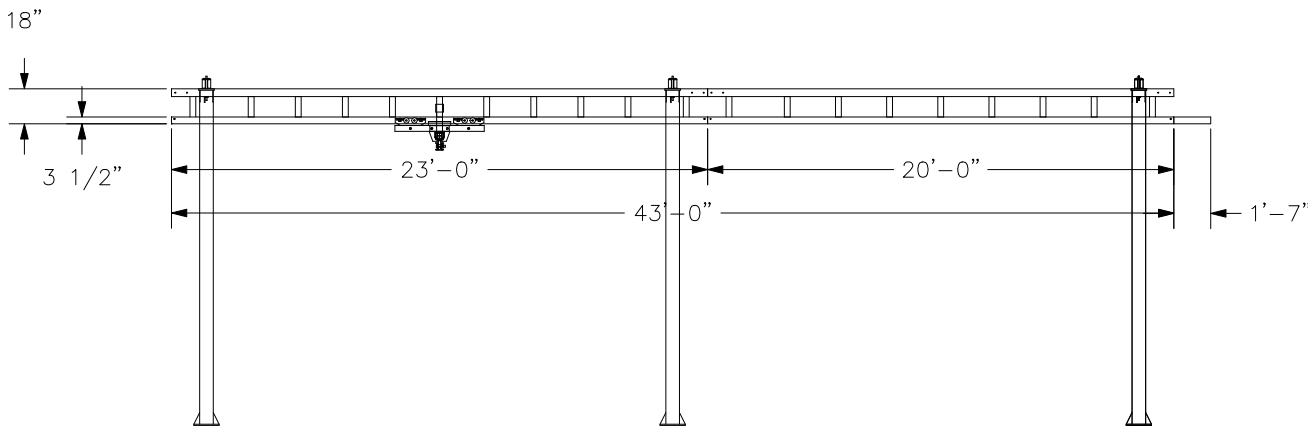

HANGERS ARE ON 20' CENTERS MAXIMUM WITH A 48" CANTILEVER ON EACH END MAXIMUM. HANGERS MUST BE WITHIN 48" OF SPLICE JOINT

DO NOT SCALE FROM DRAWING. DIMENSIONS ARE STEEL TO STEEL AND MAY VARY. HANGER POSITION TOLERANCE = ±2 1/2"

CREATED BY: WISCOLIFT INC

CRANE INFORMATION		<b>GORBEL</b> <b>600 FISHERS RUN</b> <b>P.O. BOX 593</b> <b>FISHERS, NY 14453-0593</b>	
CAPACITY: 4000LBS/BR			
BRIDGE OAL: 15'-0"		GLCS-FS-4000-15-43-12	
BRIDGE SERIES: 4000		GENERAL ARRANGEMENT	
RUNWAY OAL: 43'-0"		BY: bilcon	
RUNWAY SERIES: 4000		DATE: AUG 5, 2015	
TOLERANCE: ±1/8		LINE #: 2	
QUANTITY: 1		P/N: DEMO4000FS.2A	
I.D. #: DEMO4000FS.2A			