

PATHWAY® HD

Code Compliant Modular Access System

TECHNICAL SPECIFICATIONS



Manufactured in the USA

© Homecare Products, Inc. All rights reserved. All text and images contained in this document are proprietary and may not be shared, modified, distributed, reproduced, or reused without the express written permission of EZ-ACCESS®, a division of Homecare Products, Inc.

18555 REV 06-14-2023

OVERVIEW

SCOPE OF WORK: PROVIDE PREFABRICATED MODULAR ALUMINUM ACCESS RAMPS AND STEPS

1. SUBMITTALS

- 1.1 Product Literature must be submitted with bid.
- 1.2 Warranty must be submitted with bid.
- 1.3 Shop Drawings: Include detailed shop drawings upon receipt of purchase order.
- 1.4 Engineering: Provide sealed professional engineering drawings or empirical independent test results upon request.

2. QUALITY ASSURANCE

- 2.1 Manufacturer: EZ-ACCESS, a division of Homecare Products, Inc., 1002 15th St SW, Suite 218 Auburn, WA 98001
Toll free: (800) 451-1903 or Fax (800) 630-2350. Website: www.ezaccess.com. Any alternate manufacturer must be approved prior to bid opening.
- 2.2 All components shall be reusable and shall be easy to disassemble and reassemble so the ramp system can be relocated.
- 2.3 Design of all aluminum members shall conform to the 2018 edition of the International Building Code (IBC).
- 2.4 All exposed surfaces shall be smooth and free of sharp or jagged edges.
- 2.5 All components shall have a mill finish.
- 2.6 All fasteners shall be corrosion resistant.
- 2.7 Warranty: EZ-ACCESS, a division of Homecare Products, Inc., warrants its products to be free from defects in manufacturing material and workmanship for a period of three years beginning at date of delivery of product. This warranty excludes any defects resulting from abnormal use in installation, service, accidental or intentional damage or any occurrences beyond the manufacturer's control.

3. PRODUCTS

3.1 RAMP SECTIONS

3.1.1 Engineering

- 3.1.1.1 Ramp Sections shall be designed for a Uniform Live Load of 100 pounds per square foot (psf) minimum and a concentrated vertical load of 300 pounds.
- 3.1.1.2 Aluminum structural design shall conform to the aluminum association specifications and guidelines for aluminum structures.

3.1.2 Materials

- 3.1.2.1 Ramp Sections shall be constructed using 6000 series aluminum alloy with 6061-T6 or 6005-T5 being used for structural components.

3.1.3 Design

- 3.1.3.1 Ramp sections shall be prefabricated in 2', 3', 4', 5' and 6' lengths in addition to a distinctive 6' starter ramp section.
- 3.1.3.2 All ramp sections shall be designed for a 1:12 slope when assembled.
- 3.1.3.3 Ramp walking surface, for the standard 48", 54", and 60" ramps, shall be a clear width of 48", 54", and 60, respectively.
- 3.1.3.4 Ramp edges shall have a 4" tall (minimum) curb or a barrier which does not allow passage of a 4" diameter sphere.
- 3.1.3.5 The walking surface of the ramp shall be continuous, without gaps, and shall be approximately 1-1/4" x 6" self-mating aluminum deck with extruded slip resistant surface.

3.2 LANDINGS/PLATFORMS

3.2.1 Engineering

- 3.2.1.1 Landings/platforms shall be designed for a Uniform Live Load of 100 pounds per square foot (psf) minimum and a concentrated static vertical load of 300 pounds.

3.2.2 Materials

- 3.2.2.1 Landings/platforms shall be constructed of 6000 series aluminum alloy with 6061-T6 or 6005-T5 for structural components.

3.2.3 Design

- 3.2.3.1 Landings/platforms shall be prefabricated in typical 65-1/2" square, 77-1/2" square, 65-1/2" x 77-1/2" rectangular or 65-1/2" x 89-1/2" rectangular sections.
- 3.2.3.2 Landings/platforms shall be designed for variable heights.
- 3.2.3.3 The walking surface of the landing/platform shall be continuous, without gaps, and shall be comprised of approximately 1-1/4" x 6" high self-mating aluminum deck with extruded slip resistant surface.

- 3.3 STEPS
 - 3.3.1 Engineering
 - 3.3.1.1 Step Systems shall be designed for a Uniform Live Load of 100 pounds per square foot (psf) minimum and a concentrated vertical load of 300 pounds over an area of 4 square inches.
 - 3.3.2 Materials
 - 3.3.2.1 Step Systems shall be constructed using 6000 series aluminum alloy with 6061-T6 or 6005-T5 being used for structural components.
 - 3.3.3 Design
 - 3.3.3.1 Step risers shall be between 7" maximum and 4" minimum (6" typical) high and shall be closed.
 - 3.3.3.2 Step treads shall be 11" minimum deep x 50-3/16" minimum wide between handrails, 56" between side rails.
 - 3.3.3.3 The walking surface of the step shall be without gaps and shall be composed of self-mating aluminum treads and riser closures with an extruded slip resistant surface.
- 3.4 LEGS
 - 3.4.1 Engineering
 - 3.4.1.1 The legs shall be designed to support the ramp and landing/platform sections (see sections 3.1.1.1 and 3.2.1.1).
 - 3.4.2 Materials
 - 3.4.2.1 Legs shall be all aluminum construction alloy 6061-T6 or 6005-T5.
 - 3.4.3 Design
 - 3.4.3.1 The legs shall allow for height and slope adjustments. Legs shall be designed so that they will be perpendicular to the ground and vertical loads are transmitted axially through them, regardless of slope.
 - 3.4.3.2 All legs shall have through bolted polymer 7-3/8" x 7-3/8" feet.
- 3.5 GUARDS AND HANDRAILS
 - 3.5.1 Engineering
 - 3.5.1.1 Guards and handrails shall be designed to resist a single concentrated load of 200 pounds applied at any point and in any direction at the top of the guard or handrail and to transfer this load through the supports to the structure.
 - 3.5.1.2 Guards and Handrails shall be designed and constructed to resist a load of 50 pounds per linear foot applied horizontally at the required guard height and a simultaneous load of 100 pounds per linear foot applied vertically downward at the top of the guard. Note: The loading of 3.5.1.1, 3.5.1.2, and 3.5.1.3 shall not be applied simultaneously.
 - 3.5.1.3 Guard infill (pickets, balusters, etc.) shall be designed and constructed to resist a 50-pound horizontal load applied over a one square foot area at any point in the system.
 - 3.5.2 Materials
 - 3.5.2.1 All guards, handrails, and handrail brackets shall be aluminum construction alloy 6061-T6 or 6005-T5.
 - 3.5.3 Design
 - 3.5.3.1 Handrail gripping surface shall be smooth and continuous throughout ramp sections, steps, and landings/platforms, returning to a guard or wall that is not more than 1/4" from the end of the handrail termination.
 - 3.5.3.2 The handrail shall be 1-1/2" diameter tubing. The top of the handrail shall be 36" above the walking surface. The height of the handrail above the finish surface "shall be uniform, not less than 34" (864 mm) and not more than 38" (965 mm)".
 - 3.5.3.3 Optional child handrail shall be 1-1/2" diameter tubing. The top of the child handrail shall be 25" above the walking surface.
 - 3.5.3.4 Clearance between 1-1/2" diameter handrail and nearest obstruction shall be 1-1/2" minimum except as allowed by IBC. 2-1/4" clearance is optional.
 - 3.5.3.5 Guards shall form a protective barrier of 42" high, minimum. Guards shall be designed such that a 4" sphere cannot pass through any opening. 3-15/16" maximum, 3-3/4" typical, picket spacing.

DIMENSIONAL SPECIFICATIONS

- ✓ Unless otherwise specified, weights are expressed in pounds; lengths and widths in feet and/or inches.
- ✓ Weights and dimensions are approximate, contact manufacturer for more information.

RAMPS

- ✓ Made with aircraft grade aluminum.
- ✓ Slip resistant Gecko Grip® walking surface.
- ✓ 4" side rail curb height.
- ✓ 1.5" handrail diameter.
- ✓ Handrail minimum clearance 1.5" (except as allowed by IBC)
- ✓ 36" (nominal) handrail height.
- ✓ 25" (nominal) child handrail height.
- ✓ 42" (nominal) frame (top rail) height.
- ✓ 21.5" (nominal) frame midrail height.
- ✓ Designed for a uniform live load of 100 lbs. per square foot (psf) min. and a concentrated vertical load of 300 lbs.

48" WIDE RAMPS						
	2' Ramp	3' Ramp	4' Ramp	5' Ramp	6' Ramp	Starter Ramp
Ramp Weight (lbs.)	28.5	41.3	54.1	66.9	79.8	75.1
Useable Dimensions	2' x 48"	3' x 48"	4' x 48"	5' x 48"	6' x 48"	6' x 48"
Handrail Pair Weight (lbs.)	2.5	3.3	4.2	5.1	6	5.97
Handrail w/ Child Rail Pair Weight (lbs.)	5	6.6	8.4	10.2	12	N/A
Two-Line Rail Pair Weight (lbs.)	20.2	22.5	24.7	26.9	29.1	29
Guard Pair Weight (lbs.)	23.3	28.2	33.1	37	41.9	41.7
Outside Dimensions	54.81" Foot to Foot					60.46" Foot to Foot (Welded)

TABLE 1

54" WIDE RAMPS						
	2' Ramp	3' Ramp	4' Ramp	5' Ramp	6' Ramp	Starter Ramp
Ramp Weight (lbs.)	31.2	45.3	59.3	73.4	87.5	82.3
Useable Dimensions	2' x 54"	3' x 54"	4' x 54"	5' x 54"	6' x 54"	6' x 54"
Handrail Pair Weight (lbs.)	2.5	3.3	4.2	5.1	6	5.97
Handrail w/ Child Rail Pair Weight (lbs.)	5	6.6	8.4	10.2	12	N/A
Two-Line Rail Pair Weight (lbs.)	20.2	22.5	24.7	26.9	29.1	29
Guard Pair Weight (lbs.)	23.3	28.2	33.1	37	41.9	41.7
Outside Dimensions	60.81" Foot to Foot					66.46" Foot to Foot (Welded)

TABLE 2

60" WIDE RAMPS						
	2' Ramp	3' Ramp	4' Ramp	5' Ramp	6' Ramp	Starter Ramp
Ramp Weight (lbs.)	33.1	50.8	66.7	82.4	98.3	89.5
Useable Dimensions	2' x 60"	3' x 60"	4' x 60"	5' x 60"	6' x 60"	6' x 60"
Handrail Pair Weight (lbs.)	2.5	3.3	4.2	5.1	6	5.97
Handrail w/ Child Rail Pair Weight (lbs.)	5	6.6	8.4	10.2	12	N/A
Two-Line Rail Pair Weight (lbs.)	20.2	22.5	24.7	26.9	29.1	29
Guard Pair Weight (lbs.)	23.3	28.2	33.1	37	41.9	41.7
Outside Dimensions	66.81" Foot to Foot					72.46" Foot to Foot (Welded)

TABLE 3

PLATFORMS/LANDINGS

- ✓ Made with aircraft grade aluminum.
- ✓ Slip resistant Gecko Grip® walking surface.
- ✓ 5.5" minimum landing/platform height without support legs.
- ✓ 42" (nominal) frame (top rail) height.
- ✓ 3-15/16" maximum, 3-3/4" typical guard picket spacing.
- ✓ 22" (nominal) frame midrail height (Two-Line Rails).
- ✓ Designed for a uniform live load of 100 lbs. per square foot (psf) min. and a concentrated vertical load of 300 lbs.

Platform size	5' x 5' (5 rails)	5' x 6' (5 rails)	5' x 6' (5 & 6' rails)	5' x 6" (6 rails)	6' x 6' (6 rails)	5' x 7' (5 rails)	5' x 7' (5 & 7' rails)	5' x 7' (7 rails)	1' x 4.5' Extender (1 rails)	1' x 5' Extender (1 rails)
Platform Outside Dimensions	65.5" x 65.5"	65.5" x 77.5"	65.5" x 77.5"	65.5" x 77.5"	77.5" x 77.5"	65.5" x 89.5"	65.5" x 89.5"	65.5" x 89.5"	59.5" x 17.5"	65.5" x 17.5"
Platform Only w/o Rails Weight (lbs.)	81.6	94.3	94.3	94.3	107.8	107.0	107.0	107.0	28.6	30.8
Two-Line Rail Pair Weight (lbs.)	41.8	41.8	43.6	45.4	45.4	41.8	45.8	49.8	27.6	27.6
Guard Pair Weight (lbs.)	47.0	47.0	49.6	52.2	52.2	47.0	52.6	58.2	28.2	28.2
Width to Outside of Support Feet	65.68" x 65.68"	65.68" x 77.68"	65.68" x 77.68"	65.68" x 77.68"	77.68" x 77.68"	65.68" x 89.68"	65.68" x 89.68"	65.68" x 89.68"	59.59" x 17.59"	65.59" x 17.59"

TABLE 4

LEGS

- ✓ Made with aircraft grade aluminum.
- ✓ 6061-T6 or 6005-T5 aluminum alloy construction.
- ✓ Each leg terminates into a 7.375" square polymer foot.
- ✓ 1.5" square; lengths vary.
- ✓ Weights vary by length (0.67 Lb. /inch).
- ✓ Legs install perpendicular to the ground plane; vertical loads transmit axially through legs.

STEPS

- ✓ Made with aircraft grade aluminum.
- ✓ Slip resistant, knurled Gecko Grip® walking surface.
- ✓ Standard 6" closed risers from 18" - 60".
- ✓ 1" safety tape standard; 2" safety tape available.
- ✓ Standard useable width 56".
- ✓ Standard overall width 60".
- ✓ Typical tread depth 12.5".
- ✓ Aluminum feet included for leveling on uneven surfaces.
- ✓ Designed for a uniform live load of 100 lbs. per square foot (psf) min. and a concentrated vertical load of 300 lbs. over an area of 4 square inches.

Step Height	18"	24"	30"	36"	42"	48"	54"	60"
Outside Riser Dimensions (L x W x H)	27.53" x 60" x 19.52"	40.18" x 60" x 25.44"	52.82" x 60" x 31.78"	65.47" x 60" x 37.55"	78.10" x 60" x 43.63"	90.69" x 60" x 49.93"	103.39" x 60" x 55.97"	116.03" x 60" x 62.05"
Riser Weight (lbs.)	43.84	60.81	77.91	94.97	112.07	129.16	146.22	163.33
Guard Pair Weight (lbs.)	36.74	43.85	49.98	58.35	67.68	73.76	82.11	94.34 (1)
Handrail Pair Weight (lbs.) (2)	2.74	2.74	2.74	5.78	6.30 (3)	6.30 (3)	8.35 (3)	8.35 (3)
Foot Pair Weight (lbs.)	3.04							
Step w/ Guard & Handrail (Pairs) Weight (lbs.) (4)	83.32	107.40	130.63	159.10	186.05	209.22	236.68	266.02

Note (1) – Includes 1.5" square step guard reinforcement posts.
 Note (2) – Before being trimmed to fit.
 Note (3) – Includes mid-handrail brackets and attachment hardware.
 Note (4) – Not including lower handrail return loops or upper handrail transitions.

TABLE 5

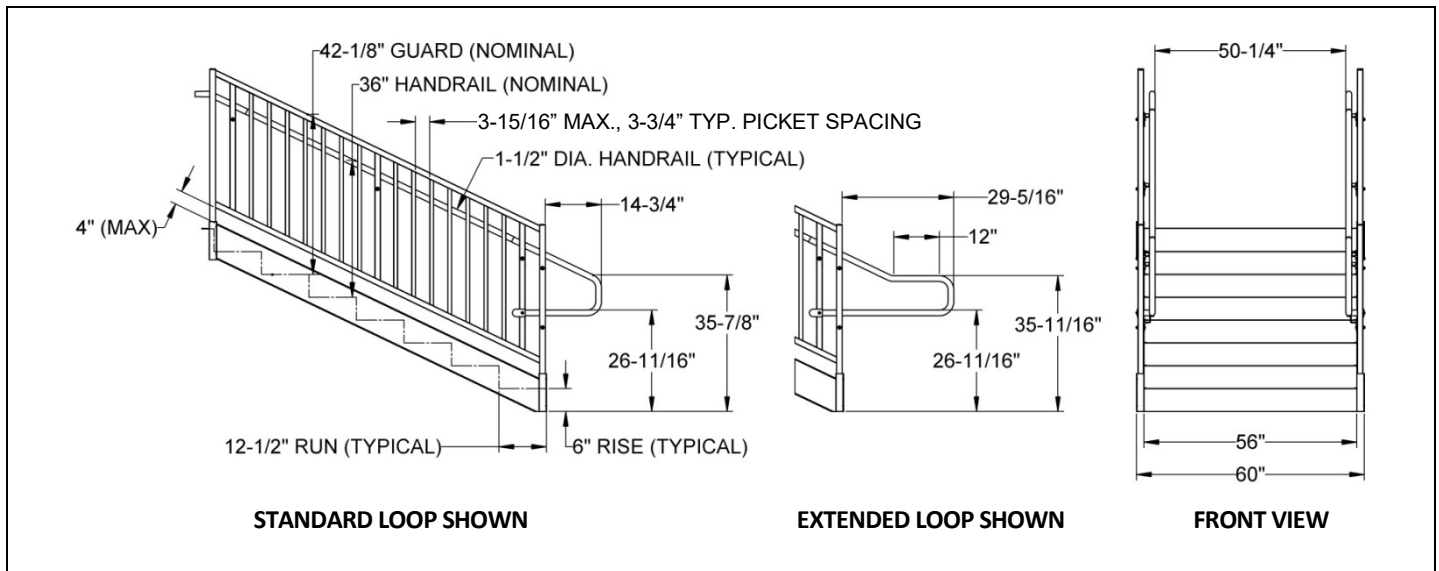

FIGURE 1

TRANSITION PLATES (OPTIONAL)

- ✓ Made with aircraft grade aluminum.
- ✓ Slip resistant walking surface.

	48" (nominal)	54" (nominal)	60" (nominal)
Length	6.73"	6.73"	6.73"
Width	47.38"	53.37"	59.37"
Weight (lbs.)	6.4	7.2	8
Anchor hole diameter	0.25"		
Anchor (hole to hole)	45.37	51.37	57.38

TABLE 6

RAMP & PLATFORM/LANDING VIEWS

Plan View

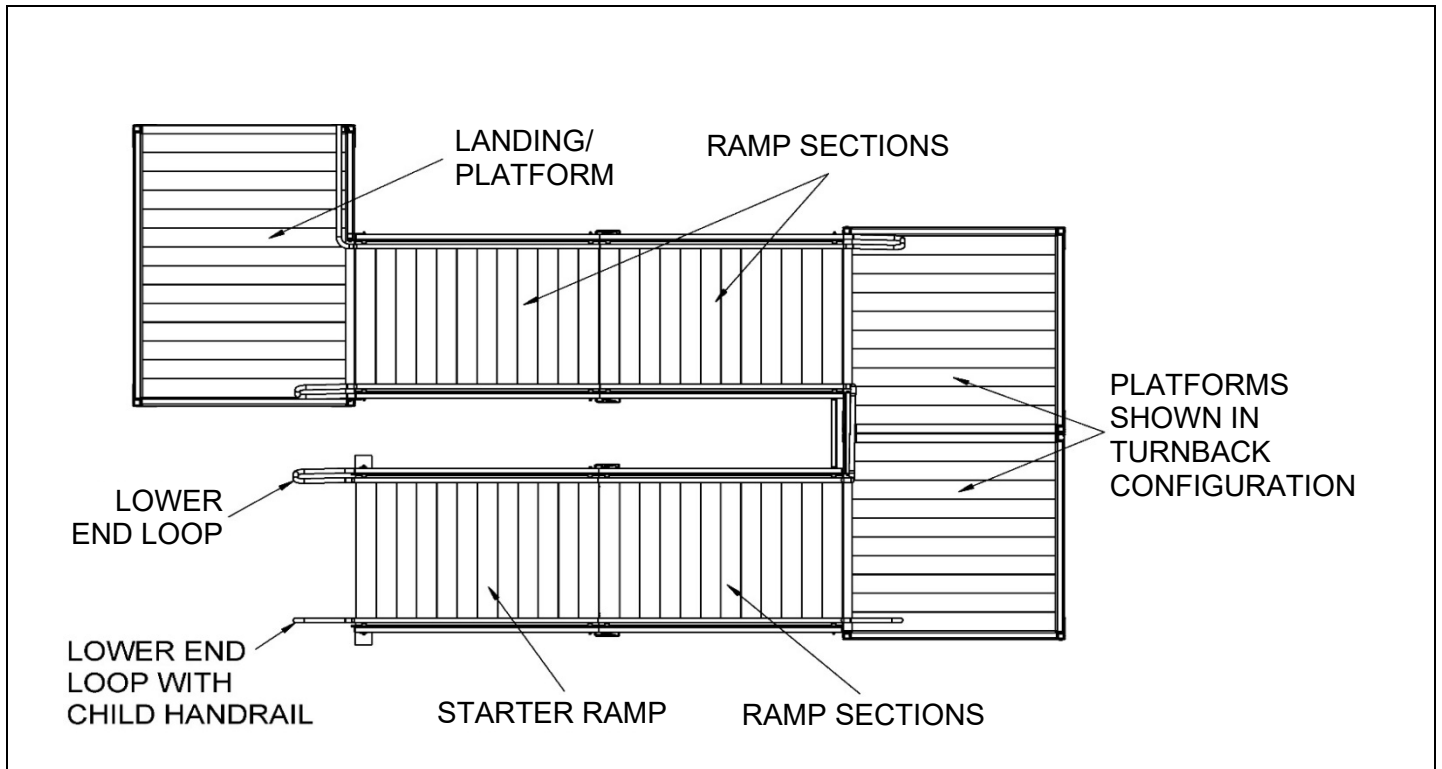

FIGURE 2

RAMP & PLATFORM/LANDING VIEWS (CONTINUED)

Isometric View

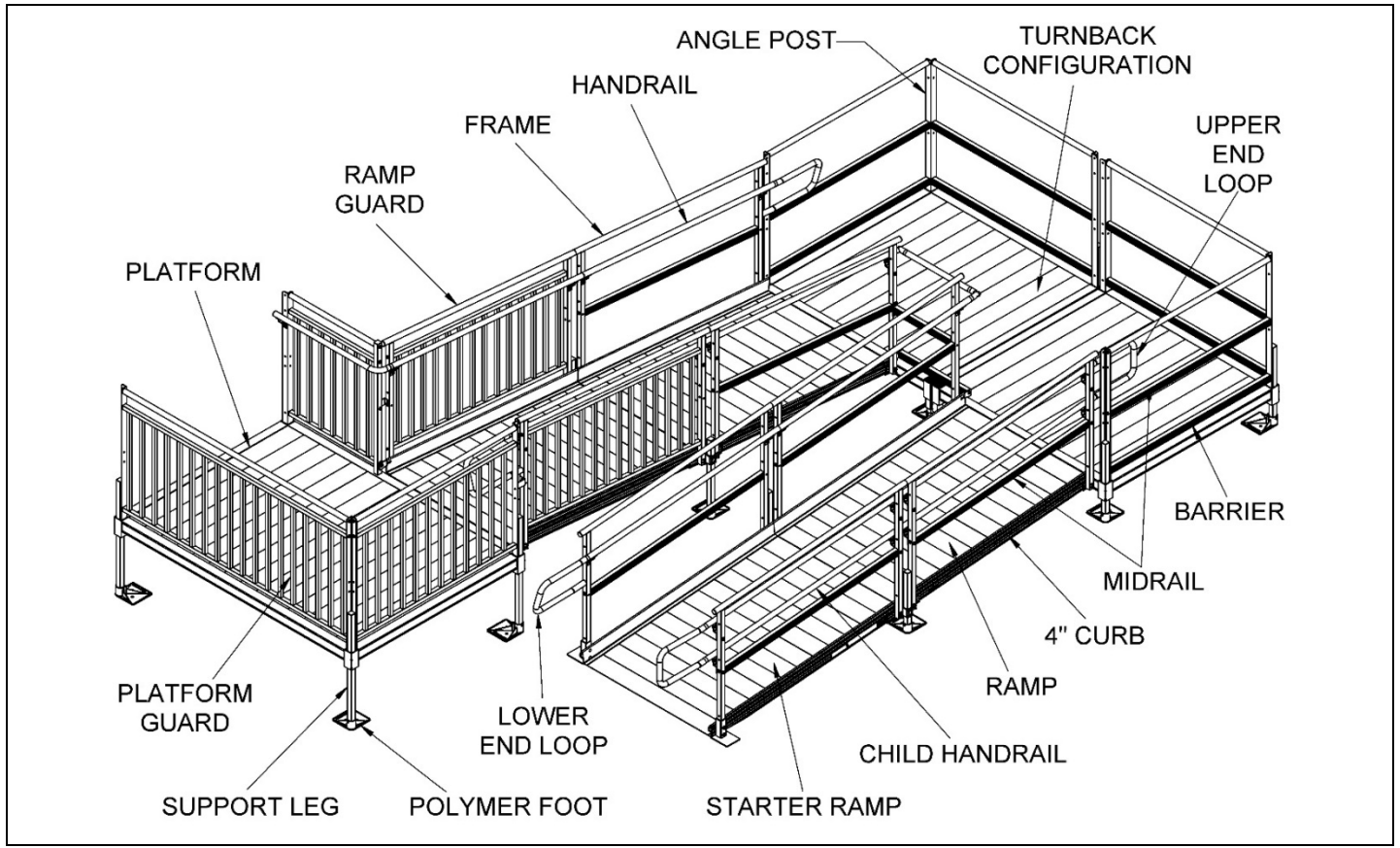

FIGURE 3

Elevation View

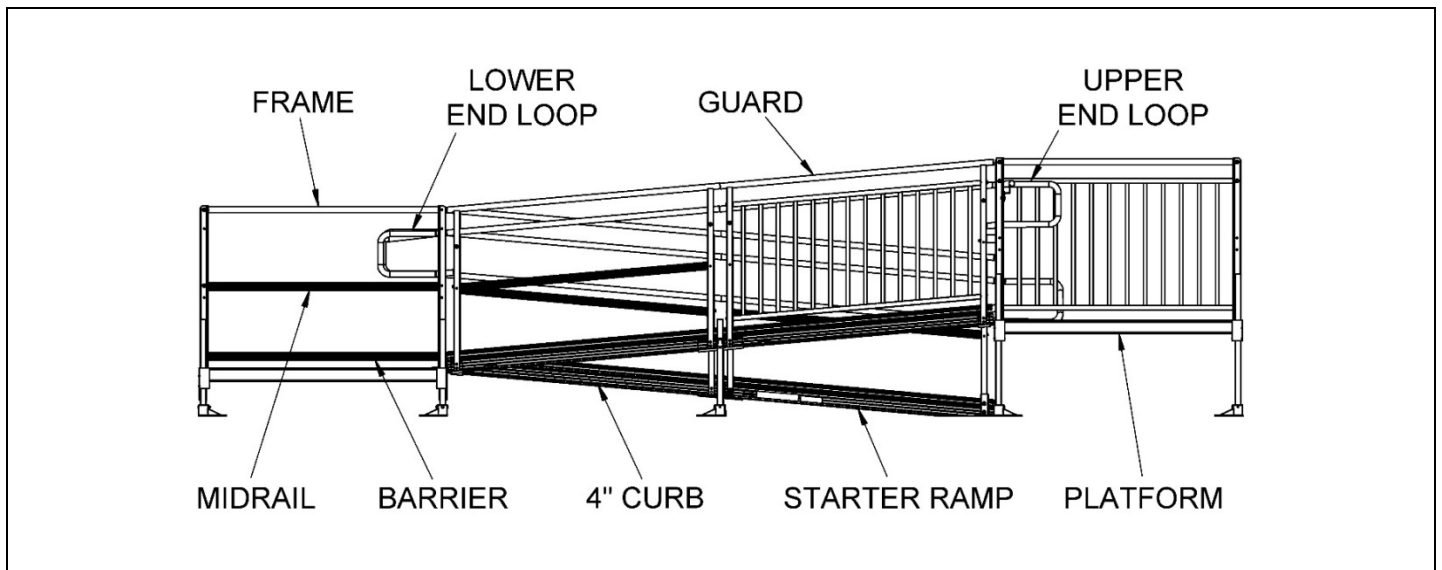

FIGURE 4

POLYMER FOOT

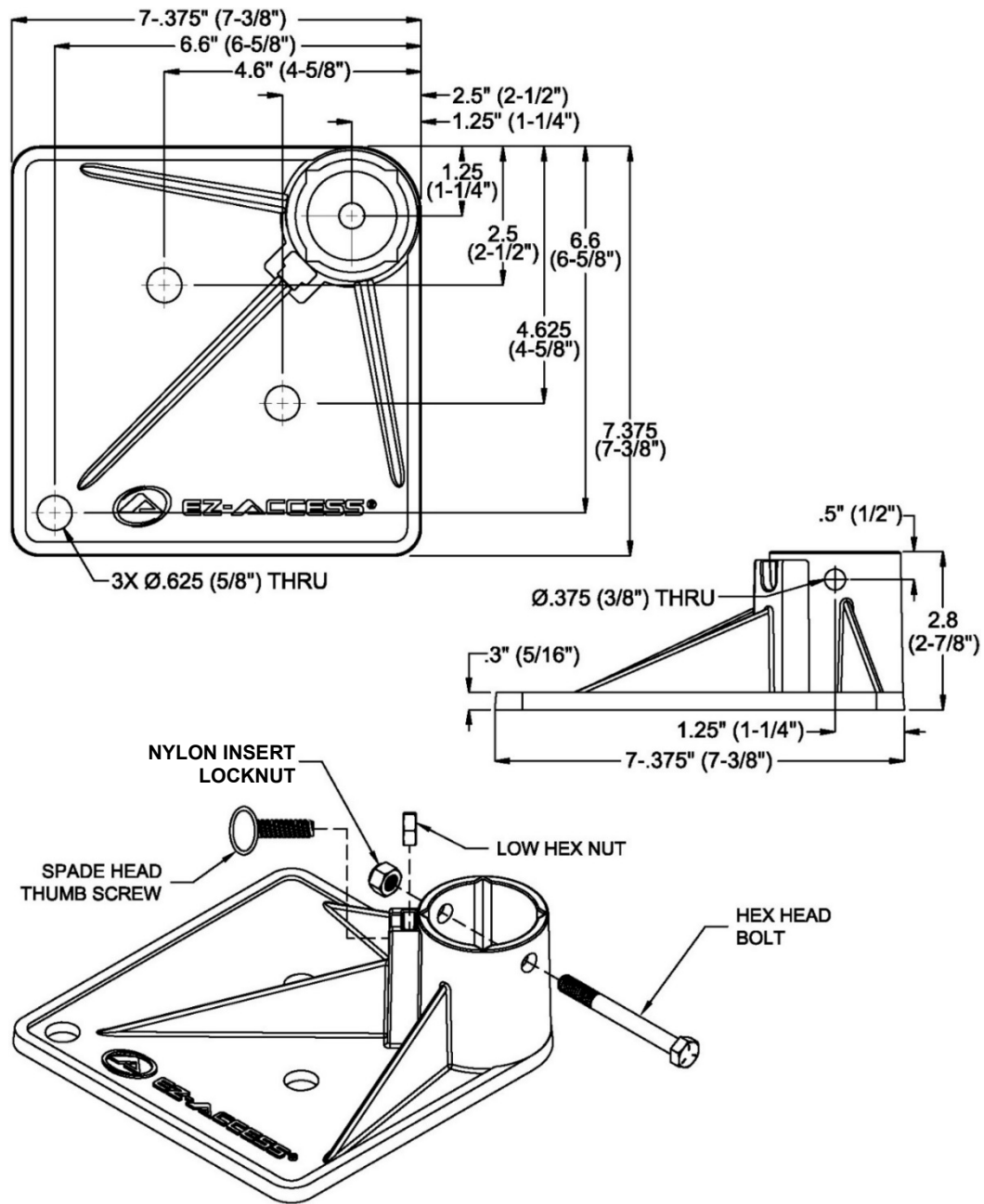

FIGURE 5