

PLAN VIEW
PATHWAY HD MODULAR ACCESS SYSTEM

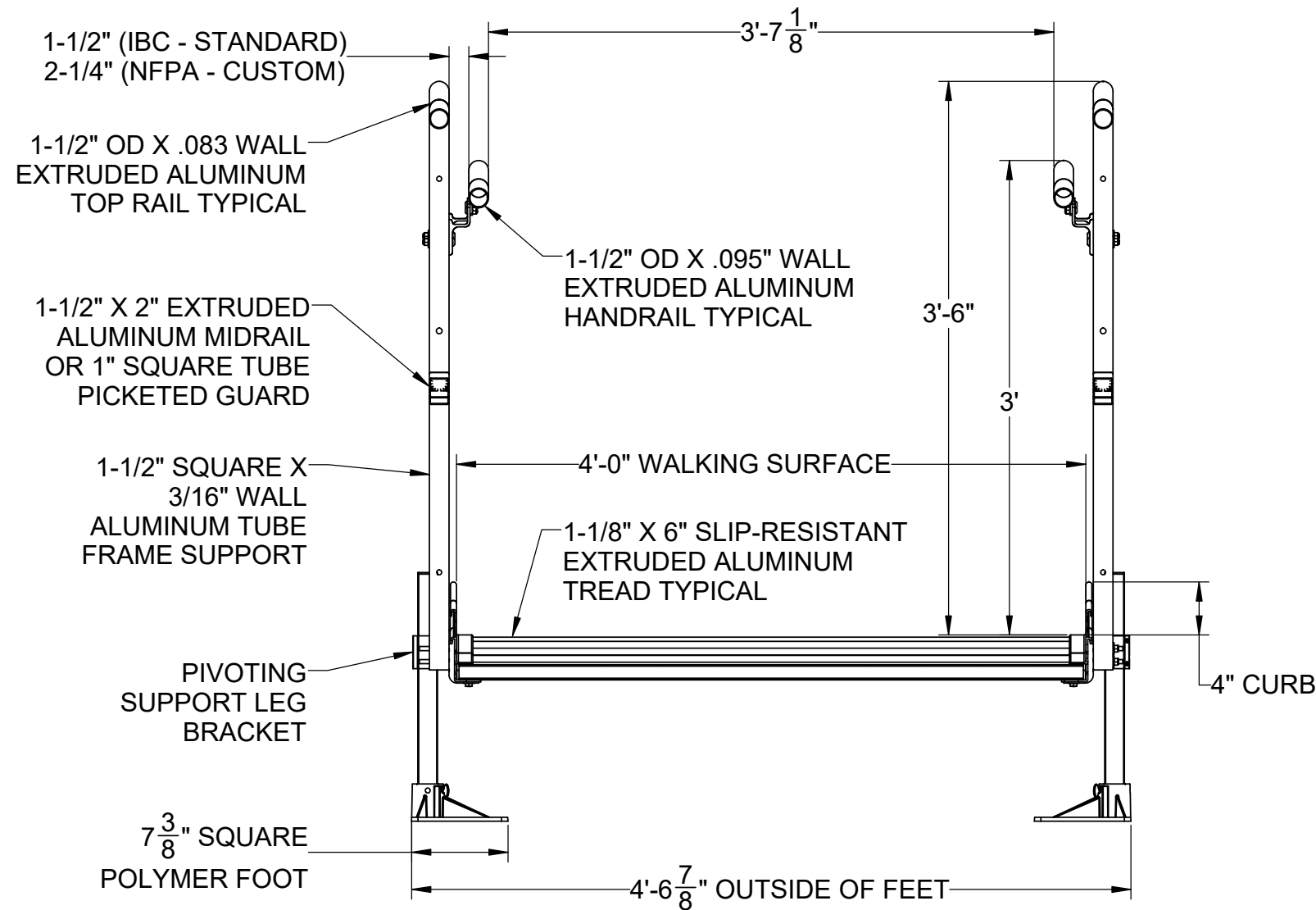

A RAMP CROSS SECTION
SCALE 1 : 6

GENERAL NOTES:

1. DESCRIPTIONS ARE FOR ILLUSTRATIVE PURPOSES AND MAY NOT REPRESENT ACTUAL DIMENSIONS, FIELD CONFIRMATION REQUIRED.
2. SYSTEM COMPONENTS SHALL BE DESIGNED TO MEET APPLICABLE IBC LOAD REQUIREMENTS.
3. ALUMINUM STRUCTURAL DESIGNS SHALL CONFORM TO THE ALUMINUM ASSOCIATION SPECIFICATIONS AND GUIDELINES FOR ALUMINUM STRUCTURES.
4. RAMPS, LANDINGS, STEPS, GUARDS, HANDRAILS, AND LEGS, SHALL BE CONSTRUCTED USING 6000 SERIES ALUMINUM ALLOY WITH 6061-T6 OR 6005-T5 USED FOR STRUCTURAL COMPONENTS.
5. RAMPS, PLATFORMS, AND LANDINGS, SHALL BE DESIGNED FOR VARIABLE HEIGHTS AND HAVE A CONTINUOUS WALKING SURFACE, WITHOUT GAPS, AND SHALL BE COMPRISED OF APPROXIMATELY 1-1/4" X 6" HIGH SELF-MATING ALUMINUM DECK WITH EXTRUDED SLIP RESISTANT SURFACE.
6. RAMP SECTIONS ARE PREFABRICATED 2', 3', 4', 5', AND 6' LENGTHS AND ARE 48" OR 54" CLEAR WIDTH & HAVE A MINIMUM 4" CURB OR BARRIER.
7. ALL FASTENERS SHALL BE CORROSION RESISTANT.
8. RAMPS SHALL BE DESIGNED FOR A 1:12 SLOPE WHEN ASSEMBLED.
9. HANDRAIL SHALL BE 1-1/2" DIAMETER TUBING, THE TOP OF WHICH SHALL BE 36" ABOVE THE WALKING SURFACE.
10. OPTIONAL CHILD HANDRAIL SHALL BE 1-1/2" DIAMETER TUBING. THE TOP OF WHICH SHALL BE 25" ABOVE THE WALKING SURFACE.
11. HANDRAIL GRIPPING SURFACE SHALL BE SMOOTH AND CONTINUOUS THROUGHOUT RAMP SECTIONS, STEPS, AND LANDINGS.
12. LANDINGS SHALL BE PREFABRICATED IN TYPICAL 65-1/2" SQUARE, 77-1/2" SQUARE, 65-1/2" X 77-1/2" RECTANGULAR OR 65-1/2" X 89-1/2" RECTANGULAR SECTIONS.
13. INTERMEDIATE (RESTING) LANDINGS SHALL BE PROVIDED AT INTERVALS OF 30 INCHES OF VERTICAL RISE AND AT EACH DIRECTION CHANGE.
14. GUARDS SHALL FORM A PROTECTIVE BARRIER A MINIMUM OF 42" HIGH AT ELEVATIONS OF 30" AND ABOVE.
15. LEGS SHALL ALLOW HEIGHT ADJUSTMENT WHILE KEEPING LEGS PERPENDICULAR TO THE GROUND.
16. LEGS SHALL HAVE THROUGH BOLTED 7-3/8" X 7-3/8" POLYMER FOOT.
17. STEP RISERS SHALL BE CLOSED AND BETWEEN 7" MAX. AND 4" MIN. HIGH AND TREADS SHALL BE 11" MIN. DEEP X 48" MIN. WIDE BETWEEN HANDRAILS.

PROPRIETARY AND CONFIDENTIAL

© EZ-ACCESS®, A DIVISION OF HOME CARE PRODUCTS, INC. ALL RIGHTS RESERVED. ALL TEXT AND IMAGES CONTAINED IN THIS DOCUMENT ARE PROPRIETARY AND MAY NOT BE SHARED, MODIFIED, DISTRIBUTED, REPRODUCED, OR REUSED WITHOUT THE EXPRESS WRITTEN PERMISSION OF EZ-ACCESS.



SIZE D	PATHWAY HD 30' STRAIGHT SYSTEM	REV B
------------------	-----------------------------------	-----------------

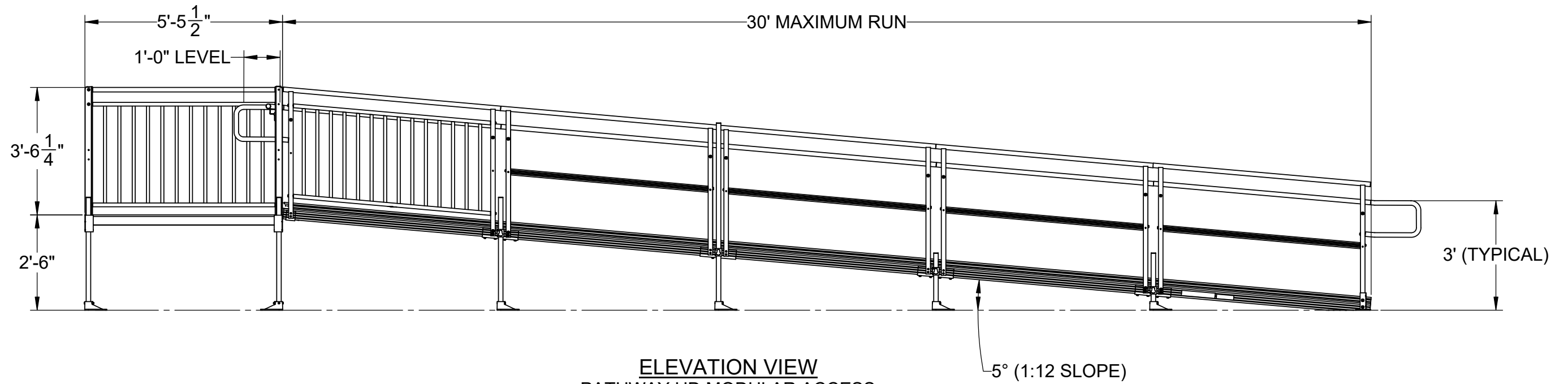

ELEVATION VIEW
 PATHWAY HD MODULAR ACCESS
 SYSTEM TWO-LINE RAIL OPTION
 (GUARDS REQUIRED AT 30" HEIGHT)

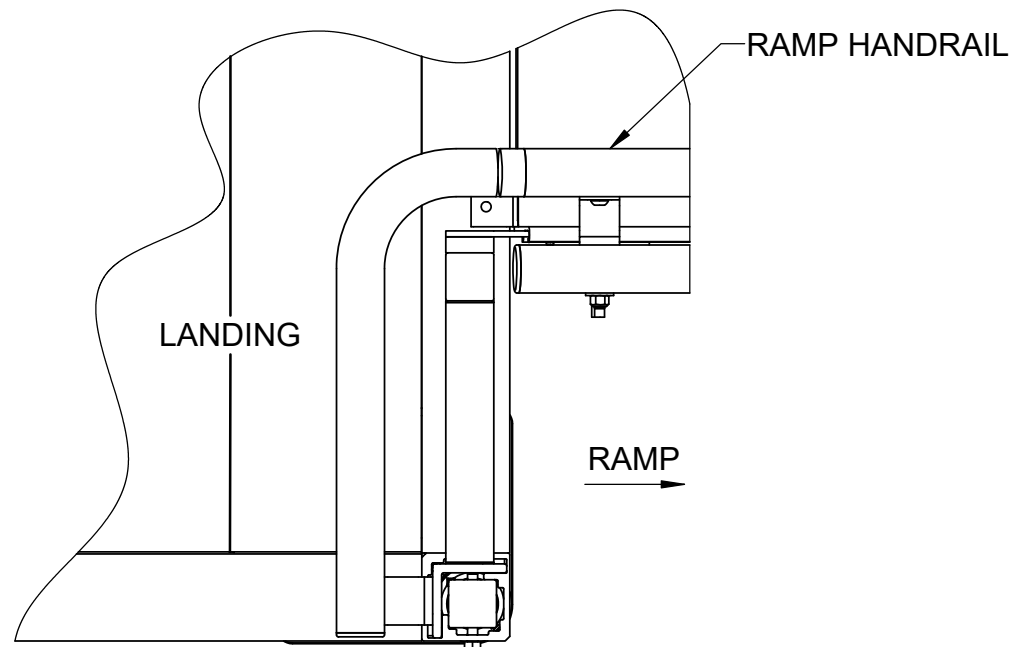

1
2 PLATFORM HANDRAIL TERMINATION DETAIL
 SCALE 1:3

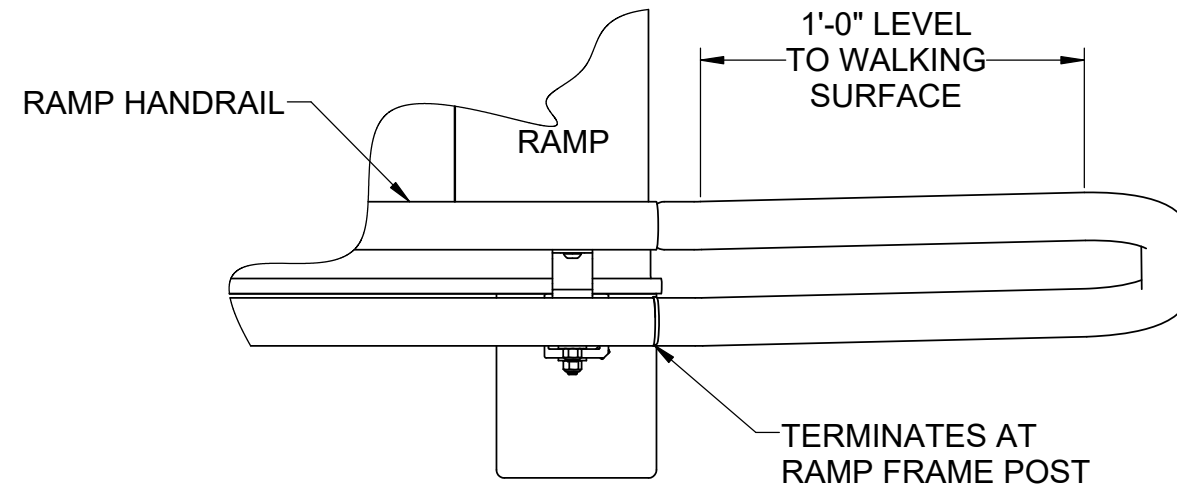

2
2 UPPER/LOWER HANDRAIL LOOP DETAIL
 SCALE 1:3

PROPRIETARY AND CONFIDENTIAL
 © EZ-ACCESS®, A DIVISION OF
 HOMECARE PRODUCTS, INC. ALL
 RIGHTS RESERVED. ALL TEXT AND
 IMAGES CONTAINED IN THIS
 DOCUMENT ARE PROPRIETARY AND
 MAY NOT BE SHARED, MODIFIED,
 DISTRIBUTED, REPRODUCED, OR REUSED
 WITHOUT THE EXPRESS WRITTEN
 PERMISSION OF EZ-ACCESS.



SIZE D	PATHWAY HD 30' STRAIGHT SYSTEM	REV B
SCALE: 1:18	WEIGHT:	SHEET 2 OF 2