



User Guide

Quality, Design and Innovation



home.liebherr.com/fridge-manuals







LIEBHERR



Contents

1	Appliance at a glance.....	3
1.1	Scope of supply.....	3
1.2	Overview of appliance and equipment.....	3
1.3	Special features.....	3
1.4	Range of use of appliance.....	3
1.5	Appliance noise emissions.....	4
1.6	Compliance.....	4
2	General safety instructions.....	4
3	Putting into operation.....	6
3.1	Installation conditions.....	6
3.2	Appliance dimensions.....	7
3.3	Transporting appliance.....	7
3.4	Unpacking appliance.....	7
3.5	Removing transport lock.....	7
3.6	Installing door handle.....	7
3.7	Mounting anti-tipping device.....	7
3.8	Installing appliance.....	8
3.9	Setting up the appliance so it is level.....	9
3.10	Installing multiple appliances.....	9
3.11	After installation.....	9
3.12	Disposing of packaging.....	9
3.13	Reversing the door.....	9
3.14	Aligning the door.....	16
3.15	Connecting appliance.....	17
3.16	Switching on appliance (first use).....	17
4	Storage.....	18
4.1	Information regarding storage.....	18
4.2	Storage times.....	18
5	Controls.....	18
5.1	Control and display elements.....	18
5.1.1	Status display.....	18
5.1.2	Display symbols.....	18
5.1.3	Acoustic signals.....	19
5.2	Navigation.....	19
5.2.1	Navigation with the touch display.....	19
5.2.2	Settings menu.....	20
5.2.3	Customer menu.....	20
5.2.4	General rules.....	20
5.3	Functions.....	20
5.3.1	Overview of functions.....	20
5.3.2	Switching appliance on and off.....	21
5.3.3	Temperature.....	22
5.3.4	Temperature recording.....	22
5.3.5	Lighting.....	23
5.3.6	Settings menu access protection.....	23
5.3.7	Access codes.....	24
5.3.8	Maintenance interval reminder.....	25
5.3.9	Language.....	25
5.3.10	Date and time.....	25
5.3.11	Temperature unit.....	25
5.3.12	Display brightness.....	26
5.3.13	Alarm Sound.....	26
5.3.14	Key Sound.....	26
5.3.15	WiFi connection.....	26
5.3.16	LAN connection.....	28
5.3.17	Info.....	29
5.3.18	Operating hours.....	29
5.3.19	Software.....	29
5.3.20	Defrosting.....	29
5.3.21	Data download / Datalogging.....	30
5.3.22	Sensor calibration.....	30
5.3.23	Temperature alarm.....	31
5.3.24	Door alarm.....	32
5.3.25	Light alarm.....	32
5.3.26	Alarm simulation.....	33
5.3.27	Alarm log.....	33
5.3.28	Alarm relay.....	34
5.3.29	DemoMode.....	34
5.3.30	Factory reset.....	34

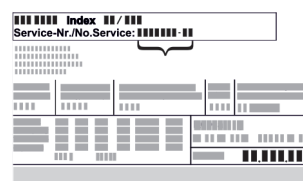
5.4	Message.....	35
5.4.1	Warnings.....	35
5.4.2	Reminders.....	37
6	Features.....	37
6.1	Safety lock.....	37
6.2	Sensors.....	38
6.3	Sensor info.....	38
6.4	Interfaces.....	38
7	Maintenance.....	39
7.1	Maintenance schedule.....	39
7.2	Defrosting appliance.....	40
7.3	Cleaning the appliance.....	40
7.4	Replacing appliance battery.....	41
8	Customer help.....	42
8.1	Technical specifications.....	42
8.2	Technical fault.....	42
8.3	Customer Service.....	43
8.4	Type plate.....	43
9	Shutting down.....	43
10	Disposal.....	44
10.1	Preparing appliance for disposal.....	44
10.2	Disposing of the appliance in an environmentally friendly manner.....	44
11	Additional information.....	44
12	Quick Start Guide for everyday use.....	45

The manufacturer is continually working on the further development of all types and models. Please be aware that we reserve the right to make changes to the shape, equipment and technology.

Symbol	Explanation
	<p>Read instructions</p> <p>Please read the information in these instructions carefully to understand all of the benefits of your new appliance.</p>
	<p>Full instructions on the internet</p> <p>You can find detailed instructions on the internet using the QR code on the front of these instruction or by entering the service number at home.liebherr.com/fridge-manuals.</p> <p>The service number can be found on the serial tag:</p>  <p style="text-align: right;"><i>Fig. Example illustration</i></p>
	<p>Check appliance</p> <p>Check all parts for transport damage. If you have any complaints, please contact your agent or customer service.</p>
	<p>Differences</p> <p>These instructions apply to a range of models, so differences are possible. Sections that apply to certain models only are marked with an asterisk (*).</p>

Symbol	Explanation
	Instructions and results Instructions are marked with a ▶. Results are marked with a ▷.
	Videos Videos about the appliances are available on the YouTube channels of Liebherr-Hausgeräte.

These operating instructions apply to:

- SRFvh 4001
- SRFvh 4011
- SRFvh 5501
- SRFvh 5511

1 Appliance at a glance

1.1 Scope of supply

Check all parts for transport damage. If you have any complaints, please contact your dealer or Customer Service. (see 8.3 Customer Service)

The delivery comprises the following parts:

- Free-standing appliance
- Equipment *
- Installation materials *
- Operating instructions
- Service brochure
- Quality certificate *
- Mains cable
- Handle incl. screws and Torx wrench
- Wall fastening kit

1.2 Overview of appliance and equipment

SRFvh 4001
SRFvh 5501

SRFvh 4011
SRFvh 5511

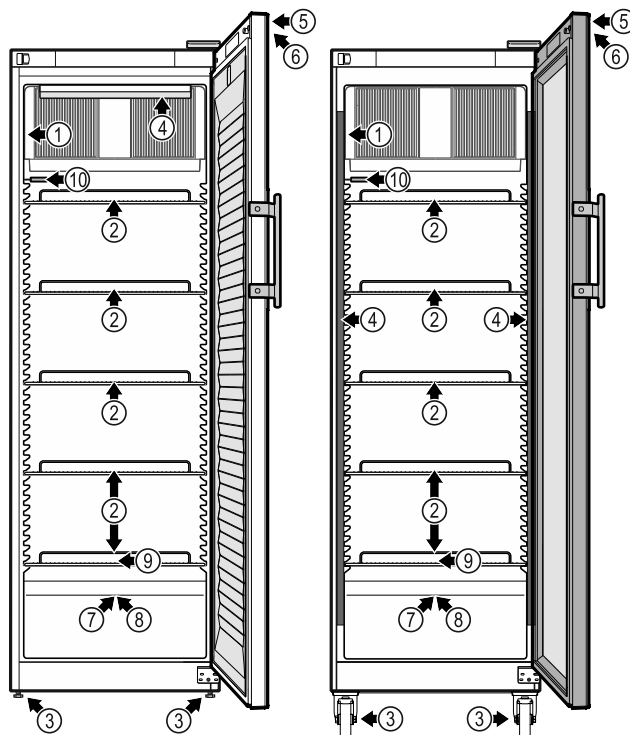

Fig. 1 Example illustration

- | Equipment | |
|------------------------------|----------------------------------------------|
| (1) Type plate | (6) Control elements and temperature display |
| (2) Grid shelves | (7) Sensor feedthrough |
| (3) Adjusting feet/castors * | (8) Safety thermostat sensor |
| (4) Interior lighting * | (9) Defrost drain water |
| (5) Lock | (10) P sensor |

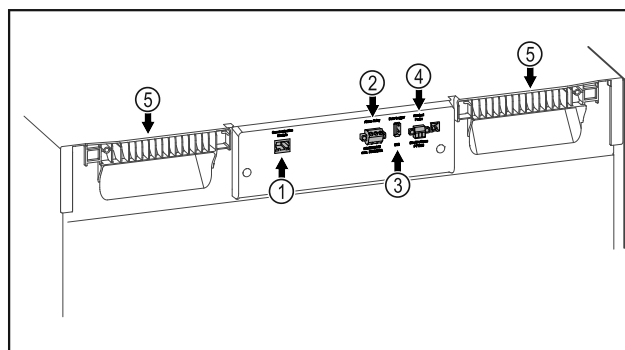

Fig. 2 Example illustration of the rear

- | Equipment | |
|---------------------------------|-----------------------------|
| (1) LAN/WiFi interface* | (4) Connection for P sensor |
| (2) Potential-free alarm output | (5) Carrying aid |
| (3) USB interface | |

1.3 Special features

Note

Accessories are available via Customer Service (see 8.3 Customer Service) and in the Liebherr-Hausgeräte-Shop at <https://home.liebherr.com>.

1.4 Range of use of appliance

Intended use

General safety instructions

This laboratory refrigerator is suitable for professional storage of products at temperatures between 3 °C and 16 °C.

Typical products to be stored include research samples, reagents, laboratory inventory etc.

The appliance meets the requirements of DIN 13277 Refrigerators and freezers for laboratory and medical applications.

It is necessary to use an independent alarm system with permanent monitoring if storing valuable or temperature-sensitive substances or products. This alarm system must be designed in such a way that every alarm state is immediately registered by a competent person who then takes appropriate measures.

Foreseeable incorrect use

Do not use the appliance for the following applications:

- Storage and refrigeration of:
 - Chemically unstable, flammable or corrosive substances
 - Blood, plasma or other body fluids for the purpose of infusion, application or introduction in the human body.
- Use in potentially explosive atmospheres.
- Use outdoors or in areas exposed to dampness and splashing water.

Improper use of the appliances will result in goods stored being damaged or spoiled.

Climate classes

The applicable climate class for your appliance is printed on the type plate.

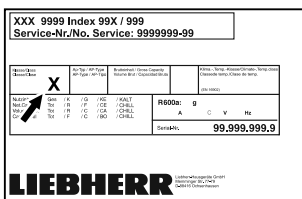

Fig. 3 Type plate

(X) The climate class states the ambient conditions in which the appliance can be operated safely.

Climate class (X)	max. room temperature in °C	max. rel. humidity in %
7	35	75

Note

The minimum permitted room temperature at the place of installation is 10 °C.

Slight condensation may form at the limit conditions on the glass door and on the side walls.

1.5 Appliance noise emissions

The A-weighted emission sound pressure level during operation of the appliance is under 70 dB(A) (sound power rel. 1 pW).

1.6 Compliance

The refrigerant circuit has been tested for leaks.

This appliance complies with the applicable safety regulations and with EU directives 2014/35/EU, 2014/30/EU and 2011/65/EU.

The installed wireless module complies with directive 2014/53/EU. Information on the wireless model (see 8.1 Technical specifications).

The full text of the EU Declaration of Conformity is available on the following website: www.liebherr.com

2 General safety instructions

Please keep these operating instructions in a safe place so you can refer back to them at any time.

If you pass the appliance on, please hand these operating instructions to the next user.

Read these operating instructions carefully before use to ensure safe and correct use of the appliance. Follow the instructions, safety instructions and warning messages included at all times. They are important for ensuring you can operate and install the appliance safely and without any problems.

Danger for the user:

- This appliance may only be used by specialist and laboratory personnel who have been trained for this purpose and are familiar with all safety measures pertaining to laboratory work. Children and persons with reduced physical, sensory or mental capabilities or lack of experience and knowledge must not commission or operate this appliance.
- The socket must be easily accessible so that the appliance can be disconnected quickly from the electricity supply in an emergency. It must not be located in the area behind the appliance.
- When disconnecting the appliance from the supply, always take hold of the plug. Do not pull the cable.

- In the event of a fault pull out the mains plug or deactivate the fuse.
- **WARNING:** Do not damage the mains power cable. Do not operate the appliance with a defective mains power cable.
- **WARNING:** Multiple sockets/distributors and other electronic equipment (such as halogen transformers) must not be placed or operated at the rear of the appliance.
- **WARNING:** Keep ventilation openings, in the appliance enclosure or in the built-in structure, clear of obstruction.
- Only customer service or other specially trained staff may repair or perform other operations on the appliance.
- Only assemble, connect and dispose of the appliance according to the instructions.

Fire hazard

- The coolant used (information on the model plate) is ecofriendly but also flammable. Any leaking coolant may ignite.
 - **WARNING:** Do not damage refrigeration circuit.
 - Do not handle ignition sources inside the appliance.
 - **WARNING:** Do not use electrical appliances in the fridge compartment which do not comply with the design recommended by the manufacturer.
 - If the refrigerant leaks: remove any naked flames or ignition sources from the vicinity of the leakage point. Properly air the room. Inform customer services.
- Do not operate the appliance close to explosive gases.
- Do not store or use petrol or other flammable gases and liquids close to the appliance.
- Do not store any explosive substances, such as aerosol containers with flammable propellant gas, in the appliance. To identify these spray cans, look for the list of contents printed on the can, or a flame symbol. Gases possibly escaping may ignite due to electrical components.
- Keep burning candles, lamps and other items with naked flames away from the appliance so that they do not set the appliance on fire.
- Alcoholic liquids or other containers with alcohol inside must only be stored tightly sealed. Any alcohol that leaks out may be ignited by electrical components.

Danger of tipping and falling:

- **WARNING:** In order to prevent danger due to an unstable appliance, it must be fixed in accordance with the instructions.
- Do not misuse the plinth, drawers, doors etc. as a step or for support.

Danger of frostbite, numbness and pain:

- Avoid prolonged skin contact with cold surfaces or refrigerated/frozen goods or take protective measures, e.g. wear gloves.

Danger of injury and damage:

- **WARNING:** Do not use mechanical equipment or other methods to speed up the defrosting process other than those recommended by the manufacturer.
- **WARNING:** Risk of injury due to electric shock! There are live electrical parts under the cover.

Only have the LED interior lighting replaced or repaired by customer service or other suitably trained professionals.

- **NOTICE:** Appliance must only be used using original manufacturer accessories or using accessories from other providers approved by the manufacturer. The user bears the risk of using accessories which are not approved.

Risk of crushing

- Do not hold the hinge when opening and closing the door. Fingers may get caught.

Specialist personnel qualifications:

The appliance may only be installed, tested, maintained, and commissioned by specialist personnel who are familiar with the installation, commissioning, and operation of the appliance.

Specialist personnel are persons who, on account of their specialist training, knowledge and experience as well as their knowledge of the relevant standards, are able to assess and perform the work assigned to them and identify potential hazards. They must have training, instruction, and authorisation to work on the appliance.

Symbols on the appliance:



This symbol may be located on the compressor. It relates to the oil in the compressor and makes reference to the risk that: **Swallowing or inhaling can be fatal.** This advice is only relevant to recycling. There is no danger in normal operation.

Putting into operation



WARNING: Danger of fire / flammable materials. This symbol is located on the compressor and indicates the danger of flammable materials. Do not remove the sticker.

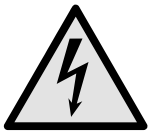

The symbol is located on the back of the appliance near the alarm relay and indicates the following danger: **Electric shock!** Even if an appliance is disconnected from the mains there may still be extraneous voltage. Do not remove sticker.



This or a similar sticker may be located on the rear of the appliance. It refers to the foamed-in panels in the door and/or the housing. This advice is only relevant to recycling. Do not remove sticker.



This or a similar sticker may be located on the rear of the appliance. It refers to the Li-ion self-charging battery installed. This advice is only relevant to recycling. Do not remove sticker.

Li-ion

Please note the warning messages and other specific advice in the other chapters:

	DANGER	Indicates an immediately hazardous situation which will lead to death or serious injuries if it is not avoided.
	WARNING	Indicates a hazardous situation which will lead to death or serious injuries if it is not avoided.
	CAUTION	Indicates a hazardous situation which will lead to minor or moderate injuries if it is not avoided.
	NOTICE	Indicates a hazardous situation which may lead to damage to property if it is not avoided.
	Note	Indicates useful instructions and tips.

3 Putting into operation

3.1 Installation conditions



WARNING

Fire hazard due to dampness!
If live parts or the mains lead become damp this may cause short circuits.

- ▶ The appliance is designed for use in enclosed areas. Do not operate the appliance outdoors or in areas where it is exposed to splash water or damp conditions.

3.1.1 Installation location



WARNING

Leaking coolant and oil!
Fire. The coolant contained in the appliance is eco-friendly, but also flammable. The oil contained in the appliance is flammable. Escaping coolant and oil can ignite if the concentration is high enough and in contact with an external heat source.

- ▶ Do not damage the pipelines of the coolant circuit and the compressor.
- Do not install appliance in direct sunlight, next to an oven, radiator or similar.
- The best place for installation is a dry and well ventilated room.
- If the appliance is installed in a very humid environment, condensation can form on the outside of the appliance. Always ensure good airflow and ventilation in the installation location.
- The more coolant there is in the appliance, the larger the room must be in which the appliance is located. If rooms are too small, any leak may create a flammable mixture of gas and air. For every 8 g of coolant, the size of the installation space must be at least 1 m³. Information regarding the coolant contained is on the type plate inside the appliance.
- The floor of the location must be horizontal and even.
- The installation location must be able to withstand the weight of the appliance plus weight when stocked to maximum level. (see 8.1 Technical specifications)

3.1.2 Electrical connection



WARNING

Danger of fire due to incorrect positioning!
If the mains cable or plug touches the back of the appliance, the vibration can damage the mains cable or the plug resulting in a short circuit.

- ▶ Make sure the mains cable is not trapped under the appliance when you position the appliance.
- ▶ Stand the appliance so that it is not touched by connectors or main cables.
- ▶ Do not connect any appliances to sockets in the area of the back of the appliance.
- ▶ Do **not** place and operate multi-sockets/power distributors and other electronic devices (such as halogen transformers) at the back of the appliances.

3.2 Appliance dimensions

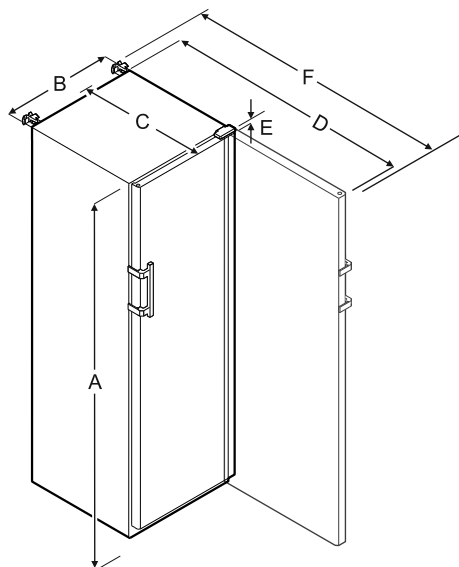

SRFvh 4001/4011					
A	B	C	D	E	F
1884 mm	597 mm	664 mm	1203 mm	23 mm	1241 mm

SRFvh 5501/5511					
A	B	C	D	E	F
1793 mm	747 mm	779 mm	1468 mm	23 mm	1506 mm

- A = appliance height including feet/casters
- B = appliance width without handle (handle depth = 45 mm)
- C = appliance depth without handle (handle depth = 45 mm)
- D = appliance depth with door open
- E = hinge height
- F = appliance depth with protruding handle and anti-tipping device

3.3 Transporting appliance



WARNING

Risk of injury due to broken glass!*
When transporting at an altitude of more than 1500 m, the glass panes of the door may break. This can result in sharp-edged fragments, which can cause serious injuries.

- ▶ Take appropriate protective action.
- ▶ On initial setup: Transport the appliance in its packaging.
- ▶ When transporting after initial setup (e.g. relocation): Transport the appliance unloaded.
- ▶ Transport the appliance upright.
- ▶ Use two people to transport the appliance.

3.4 Unpacking appliance

- ▶ Check the appliance and the packaging for damage during transport. Contact the supplier immediately if you suspect any damage. Do not connect appliance to the power supply.
- ▶ Remove all materials from the back or the side walls of the appliance that may prevent proper installation or prevent air flow and ventilation.

3.5 Removing transport lock

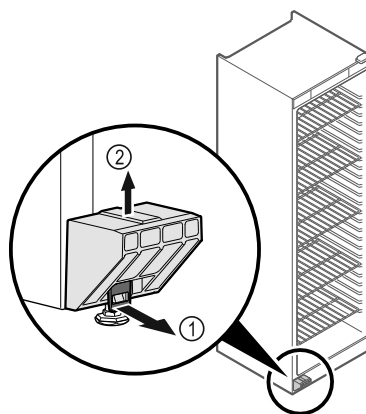

Fig. 4

- ▶ Pull tab Fig. 4 (1) forwards.
- ▶ Take off transport lock Fig. 4 (2) in upwards direction.
- ▷ Base holder remains on the appliance.

3.6 Installing door handle

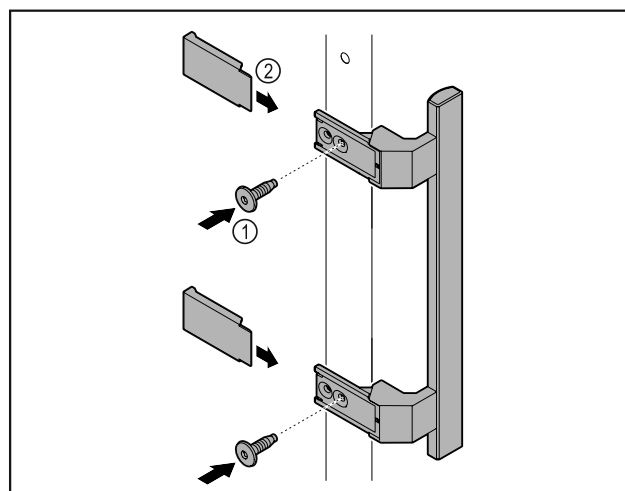

Fig. 5

- ▶ Attach handle from accessory kit to the door using the screws Fig. 5 (1) supplied.
- ▶ Put on covers Fig. 5 (2).

3.7 Mounting anti-tipping device

Tools



Fig. 6

Prevent appliance from tipping over.

Putting into operation

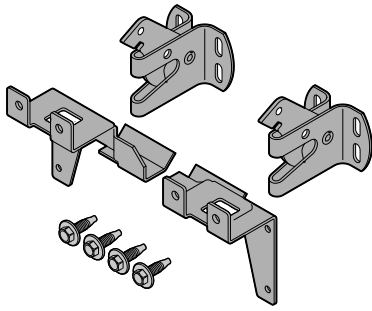

Fig. 7

The anti-tipping device, consisting of two retaining parts, two retaining hooks and four screws (4 x 14), is included with the appliance.

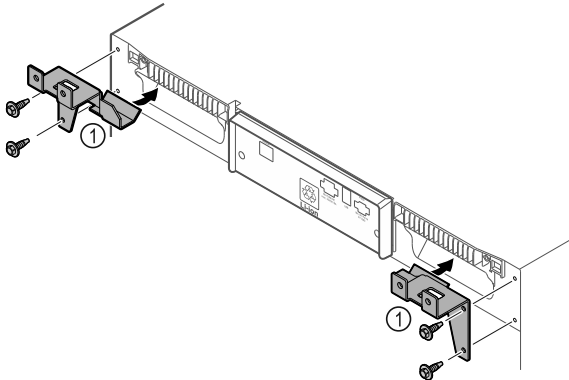

Fig. 8

- ▶ Mount retaining parts Fig. 8 (1) on the appliance using the screws supplied.
- ▶ Push appliance with retaining parts mounted against the wall.

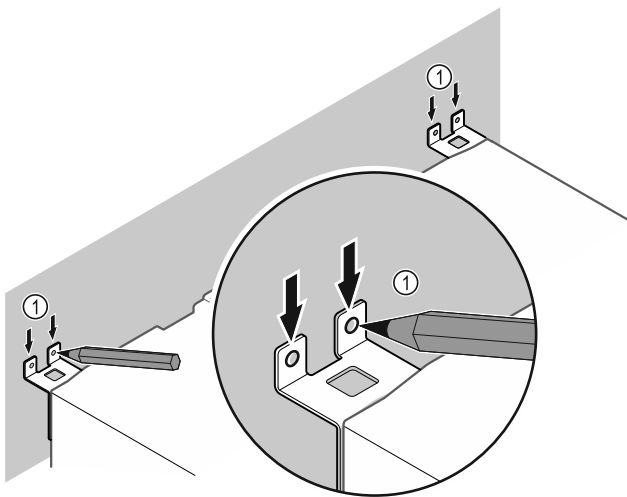

Fig. 9

- ▶ Make markings on the wall Fig. 9 (1).
- ▶ Remove appliance.

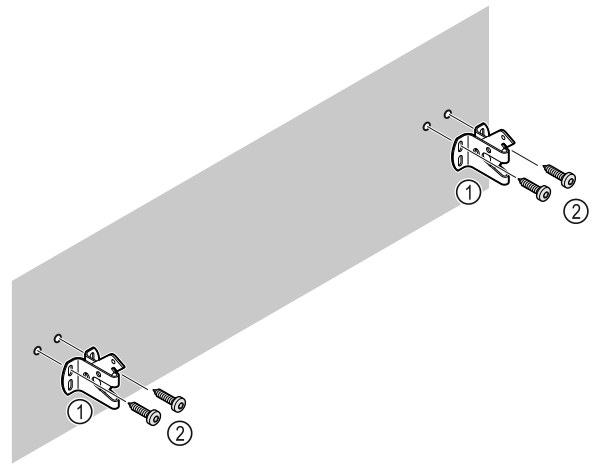

Fig. 10

Use fixing material (e.g. dowels) which is appropriate for the nature of the wall (wood, concrete) and sufficient attachment points Fig. 10 (2).

- ▶ Attach retaining hooks. Fig. 10 (1)

3.8 Installing appliance



CAUTION

Risk of injury and damage.

- ▶ Use 2 people to install appliance.



CAUTION

Risk of injury and damage.

The door can knock against the wall and become damaged as a result. In the case of glass doors, the damaged glass can cause injuries.

- ▶ Protect the door from knocking against the wall. Attach door stopper, e.g. felt stopper, to the wall.

- ▶ Connect all necessary components (e.g. mains cable) to the back of the appliance and route to the side.

Note

Cables can be damaged.

- ▶ Do not jam the cable when pushing the appliance back.

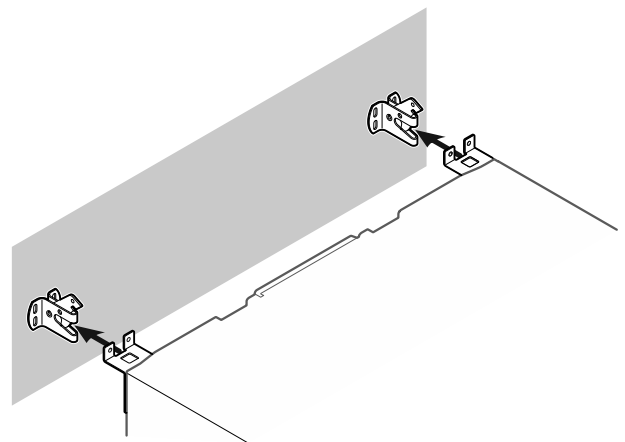

Fig. 11

- ▶ Slide appliance up against the wall so that the retaining parts latch into the securing hooks.
- ▷ The appliance is now secured against tipping.
- ▷ It can be released by folding back the securing hooks.

3.9 Setting up the appliance so it is level

NOTICE

Appliance body is deformed and door does not close.

- ▶ Align appliance horizontally and vertically.
- ▶ Compensate for uneven floors using adjustable feet.



WARNING

Incorrect height adjustment of the adjustable foot!
Can cause severe or even fatal injury. Incorrect height adjustment can cause the bottom part of the adjustable foot to come loose and the appliance to tip over.

- ▶ Do not unscrew the adjustable foot too far.

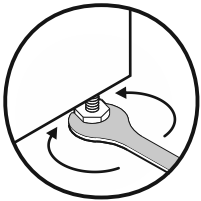

Fig. 12 *

Raising appliance:

- ▶ Turn adjustable foot clockwise.

Lowering appliance:

- ▶ Turn adjustable foot anticlockwise.

3.10 Installing multiple appliances

NOTICE

Risk of damage due to condensation between the side walls.

- ▶ Do not install the appliance directly next to another fridge.
- ▶ Install appliances with a space 3 cm between appliances.
- ▶ Only install multiple appliances up to temperatures of 35 °C and 65% humidity next to one another.
- ▶ At higher levels of humidity, increase space between appliances.

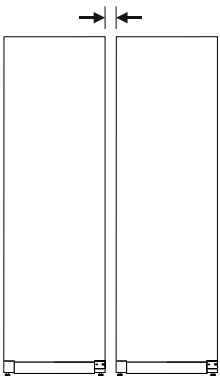

Fig. 13 Side-by-side installation

Note

A side-by-side kit is available as an accessory via Liebherr Customer Service. (see 8.3 Customer Service)

3.11 After installation

- ▶ Take off the protective film from the exterior of the appliance.
- ▶ Clean appliance. (see 7.3 Cleaning the appliance)
- ▶ If necessary: Disinfect the appliance.

- ▶ Keep the invoice so you have the appliance and dealer information available if needed.

3.12 Disposing of packaging



WARNING

Danger of suffocation due to packing material and plastic film!

- ▶ Do not allow children to play with packing material.

The packaging is made of recyclable materials:

- corrugated board/cardboard
- expanded polystyrene parts
- polythene bags and sheets
- polypropylene straps
- nailed wooden frame with polyethylene panel*

- ▶ Take the packaging material to an official collecting point.



3.13 Reversing the door

Tools

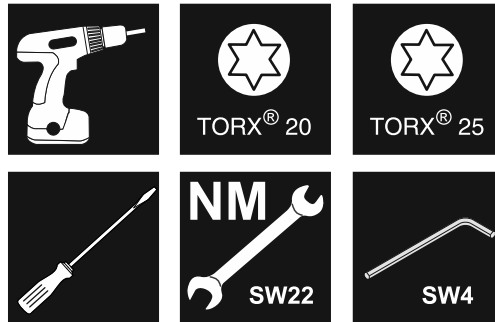

Fig. 14



WARNING

Risk of injury if the door is not reversed correctly!

- ▶ The door may only be reversed by qualified personnel.



WARNING

Risk of injury and material damage due to heavy door!

- ▶ Only perform the conversion if you can carry a weight of 25 kg.
- ▶ Always have someone help you carry out the conversion.

NOTICE

Live parts!

Damage to electrical components.

- ▶ Disconnect the power plug before reversing the door.

- ▶ Open the door.

Putting into operation

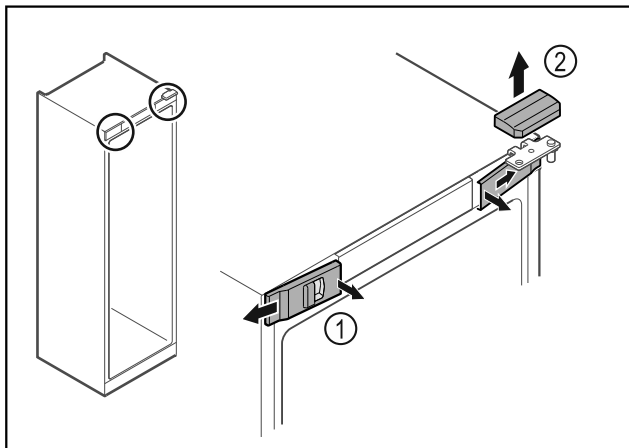

Fig. 15

- ▶ Unlatch the front covers Fig. 15 (1) on the inside and remove them sideways.
- ▶ Lift off the upper cover Fig. 15 (2).

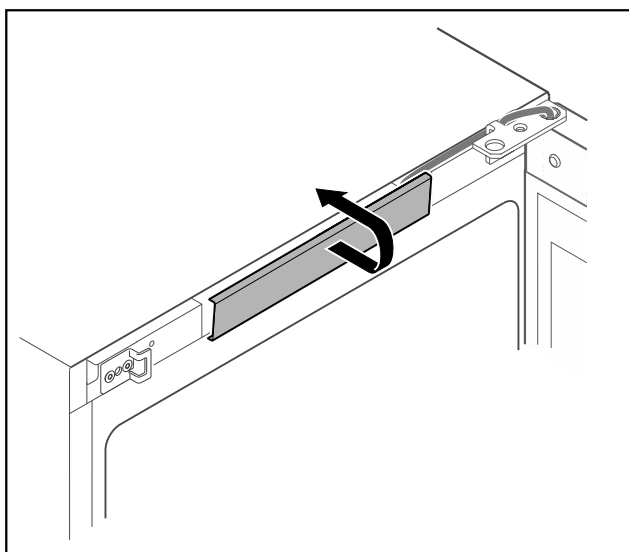

Fig. 16

- ▶ Unlatch the middle cover and remove it.

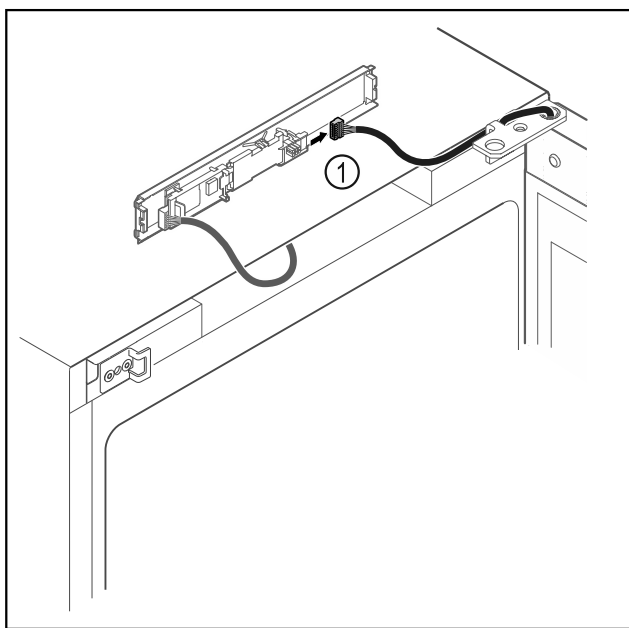

Fig. 17

- ▶ Disconnect the plug Fig. 17 (1) from the circuit board.

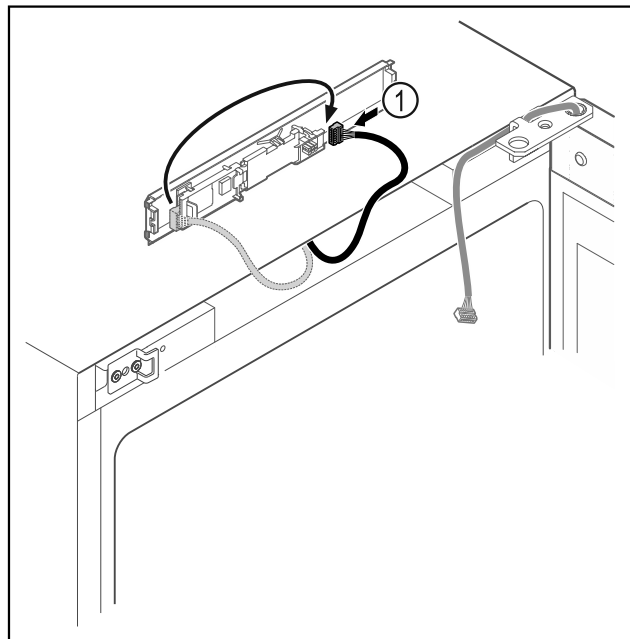

Fig. 18

- ▶ Connect the plug Fig. 18 (1) to the circuit board.

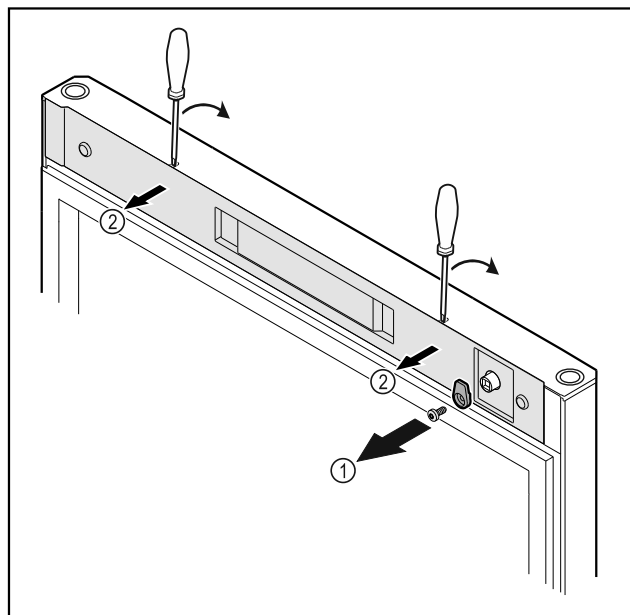

Fig. 19

- ▶ Unscrew the door latch Fig. 19 (1).
- ▶ Unlatch the cover Fig. 19 (2) with a small screwdriver and remove it.

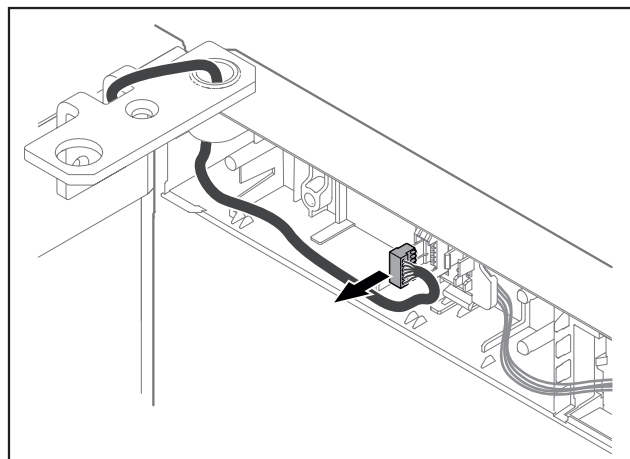

Fig. 20

- ▶ Remove the plug from the plug holder.

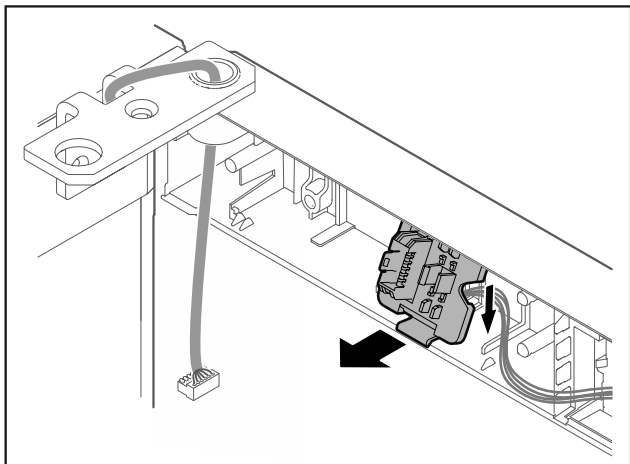

Fig. 21 The installation position of the plug holder can be rotated by 180°.

- ▶ Disengage the plug holder.

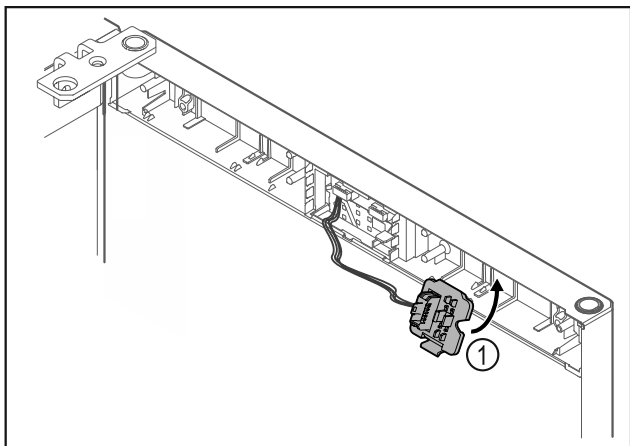

Fig. 22

- ▶ Snap in the plug holder Fig. 22 (1) on the opposite side.

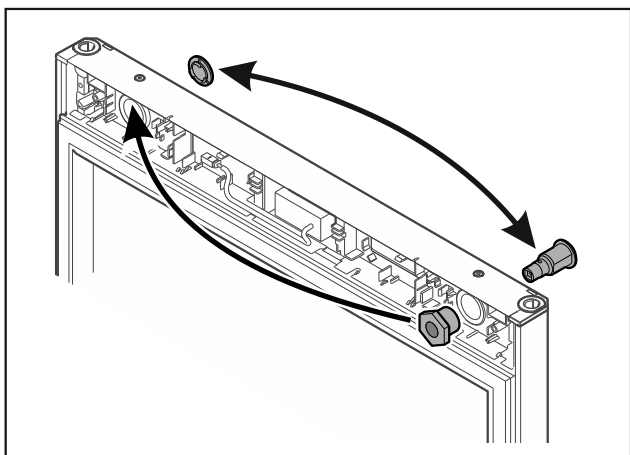

Fig. 23

- ▶ Put the lock and cover on the opposite side.

NOTICE
 Risk of injury if the door tips out!
 ▶ Hold the door.

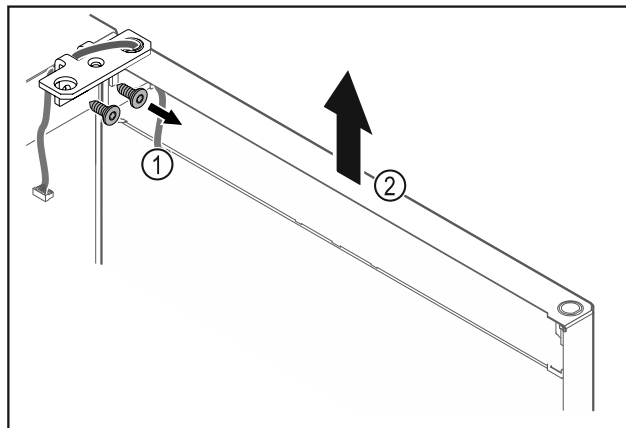

Fig. 24

- ▶ Unscrew the hinge Fig. 24 (1).
- ▶ Lift the door with the hinge straight up by Fig. 24 (2) roughly 200 mm and take it off.
- ▶ Carefully place the door on a soft surface.

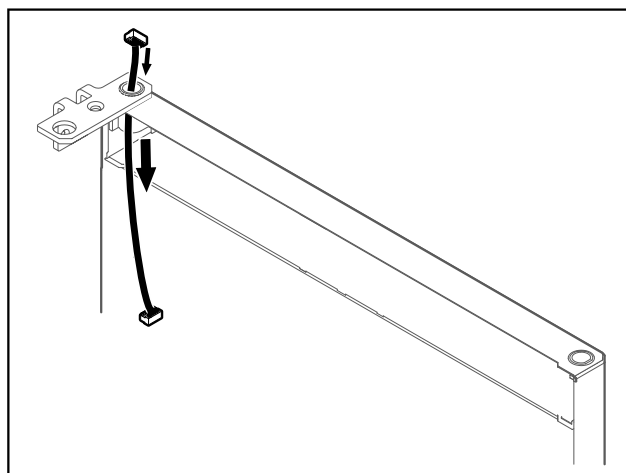

Fig. 25

- ▶ Carefully pull out the cable.

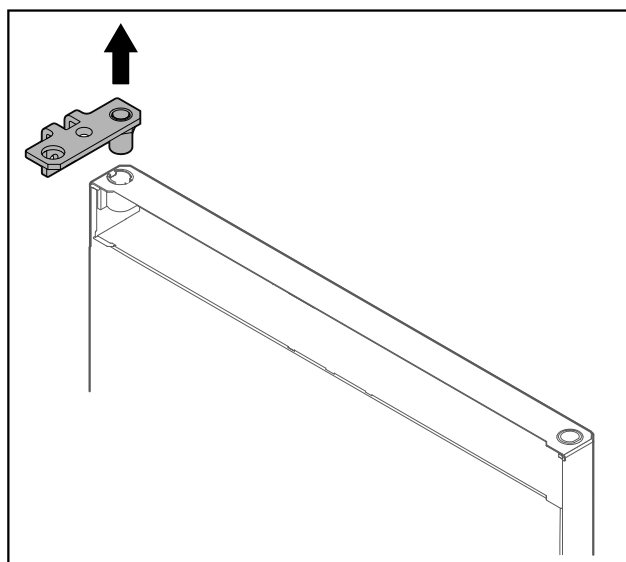

Fig. 26

- ▶ Pull out the hinge.

Putting into operation

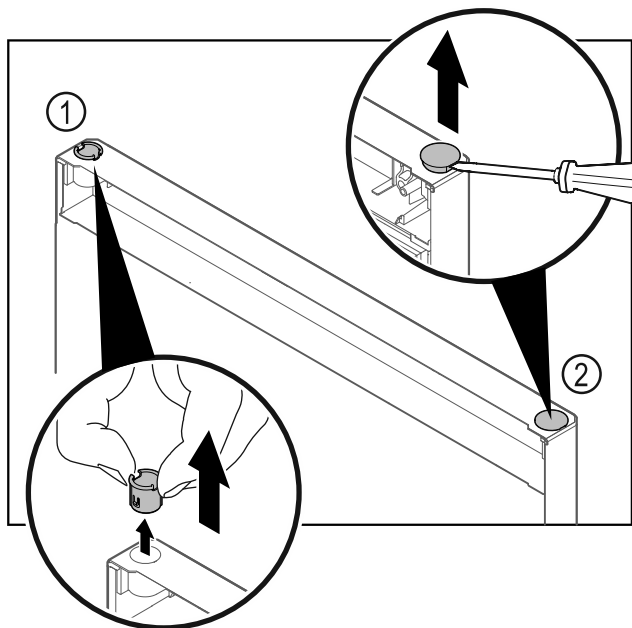

Fig. 27

- ▶ Pull out the hinge bushing Fig. 27 (1) with your fingers.
- ▶ Carefully lift the cover plug Fig. 27 (2) with a slotted screwdriver and pull it out.

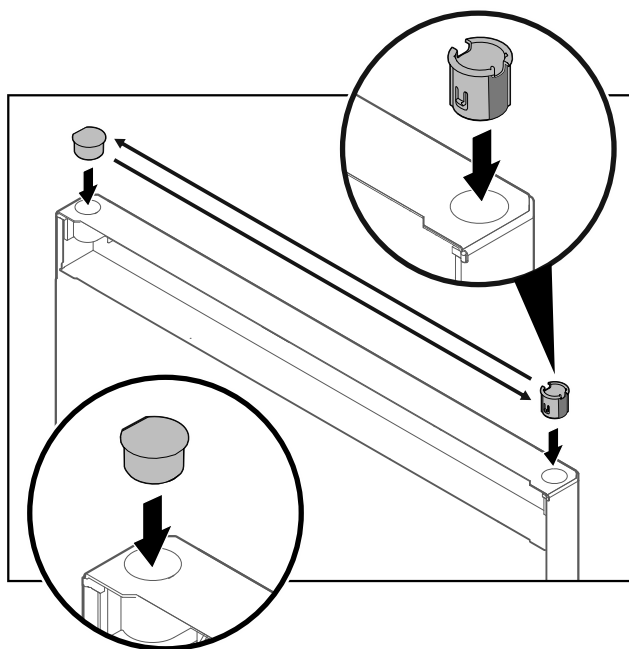

Fig. 28

- ▶ Insert hinge bushing and cover plug on the opposite side (the flattened sides face outwards).

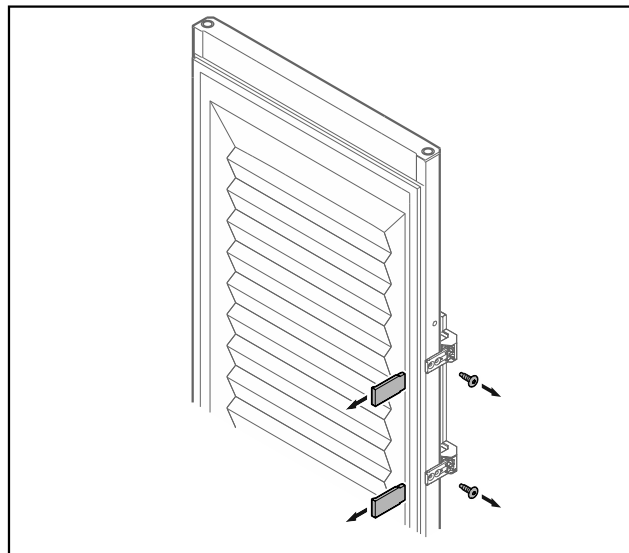

Fig. 29 Insulated door*

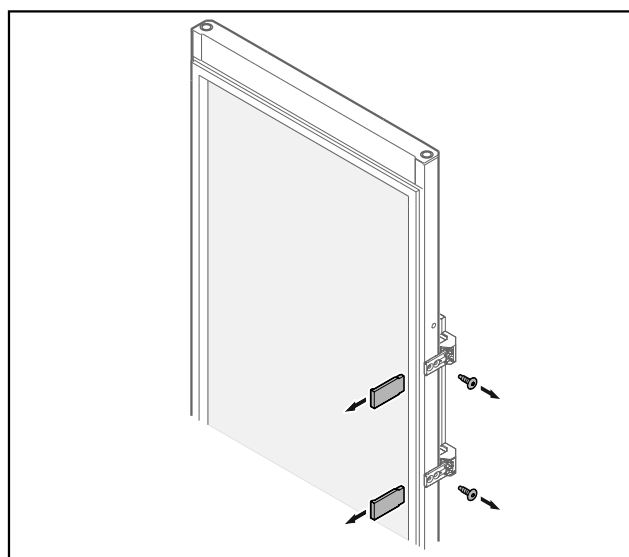

Fig. 30 Glass door*

- ▶ Remove the panels.
- ▶ Unscrew the handle.

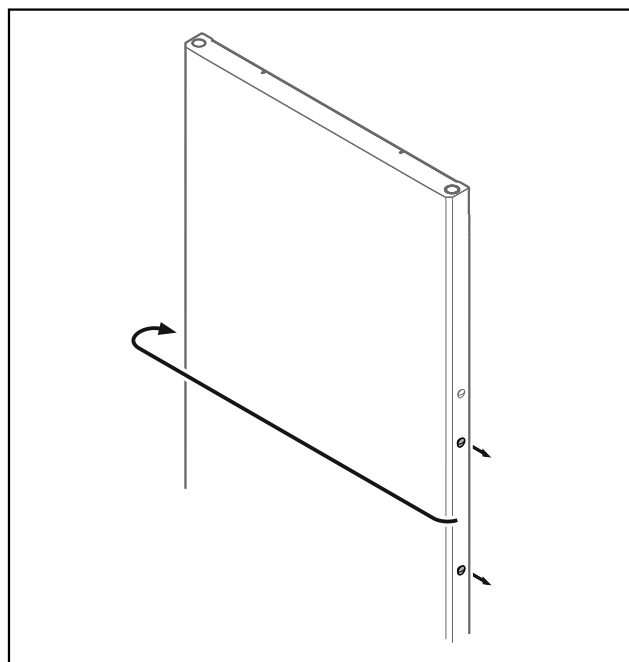

Fig. 31

- ▶ Put the stopper on the opposite side.

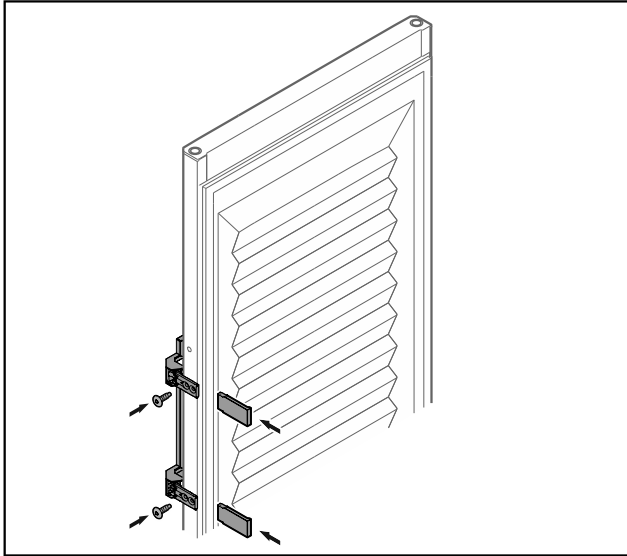

Fig. 32 Insulated door*

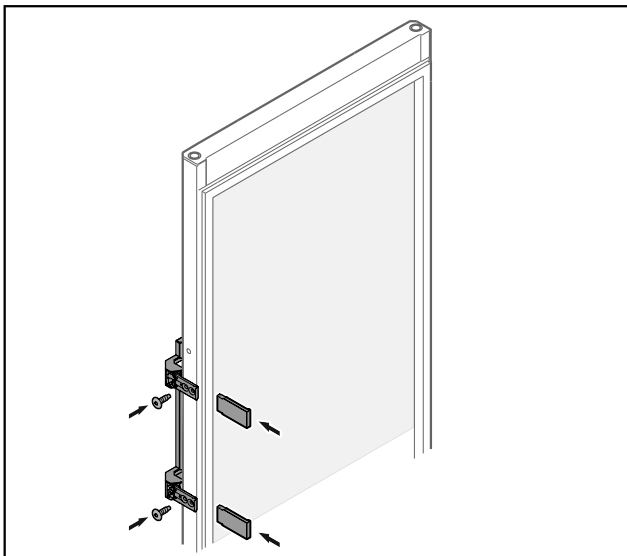

Fig. 33 Glass door*

- ▶ Screw the handle onto the opposite side.
- ▶ Attach the panels.

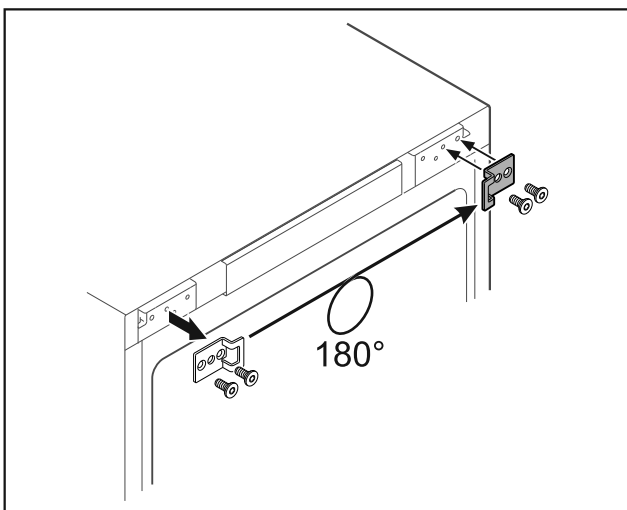

Fig. 34

- ▶ Put the closing bracket on the opposite side.

Note

The holes are pre-marked and must be pierced with the self-tapping screws.

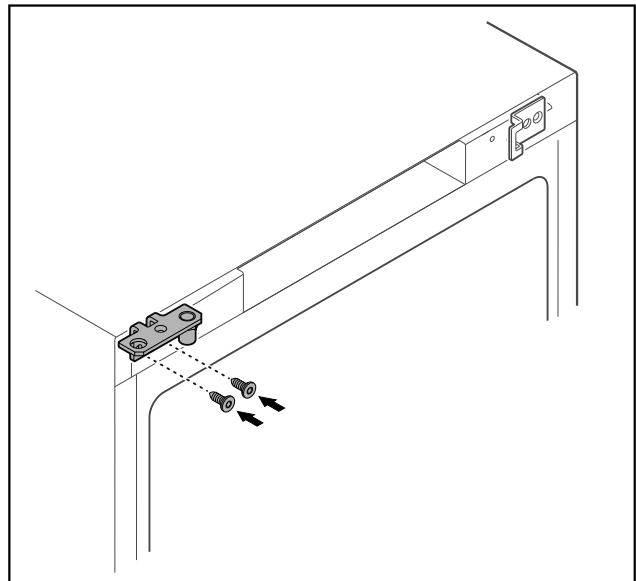

Fig. 35

- ▶ Move the hinge to the opposite side.



WARNING

Risk of injury and material damage if the door tips out!

- ▶ Tighten the bearing pins to the specified torque.

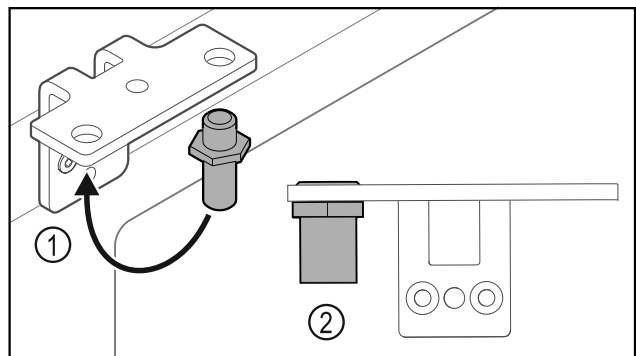

Fig. 36

- ▶ Put the pin back into the hinge Fig. 36 (1).
- ▶ Tighten the pin Fig. 36 (2) to a **torque of 12 Nm**.
- ▶ Unscrew the hinge again.

NOTICE

Risk of injury due to tensioned spring!

- ▶ Do not disassemble the door closing system Fig. 37 (1).

Putting into operation

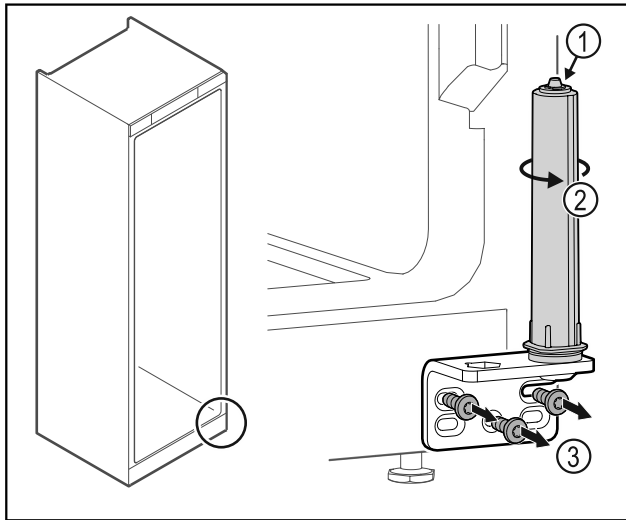

Fig. 37

- ▶ Turn the closing system Fig. 37 (2) until it clicks.
- ▷ The tension of the closing system is released.
- ▶ Unscrew the hinge Fig. 37 (3).

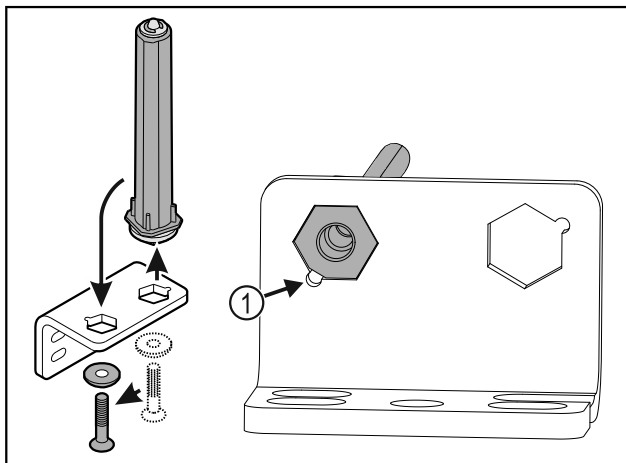

Fig. 38

- ▶ Put the door closing system in the hinge.
- ▶ Make sure the pin chamfer Fig. 38 (1) faces the round hole when you put it in.

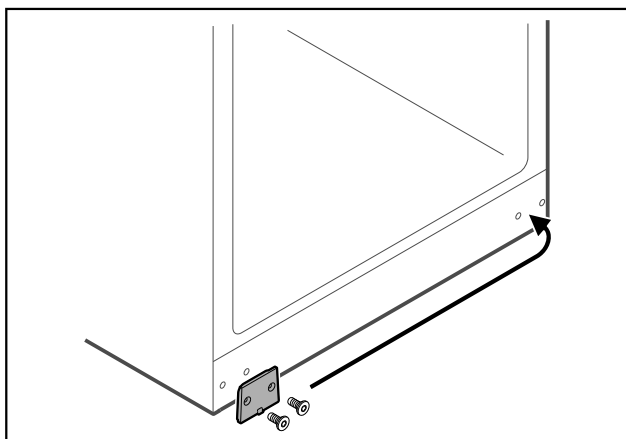

Fig. 39

- ▶ Put the cover plate on the opposite side.

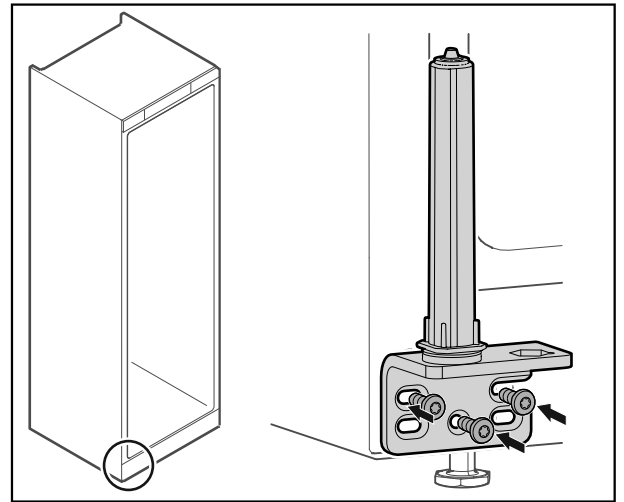

Fig. 40

- ▶ Screw the hinge onto the opposite side.

Note

Correct alignment and tension are important for the closing system to work properly.

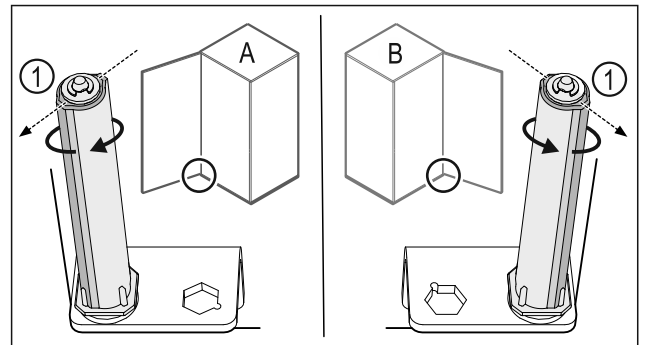

Fig. 41 Left-hinged (A) / Right-hinged (B)

- ▶ Turn the closing system against the resistance until the bar of the closing system Fig. 41 (1) points outwards.
- ▷ The closing system automatically stays in this position.
- ▷ The closing system is now aligned and tensioned.

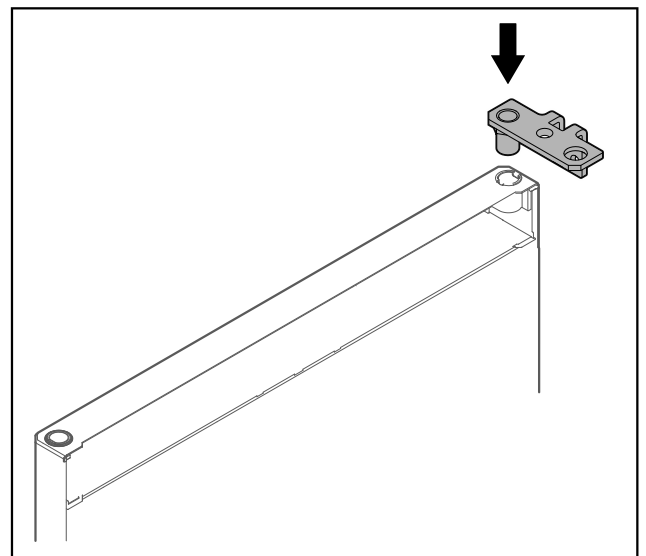

Fig. 42

- ▶ Put the hinge into the door.

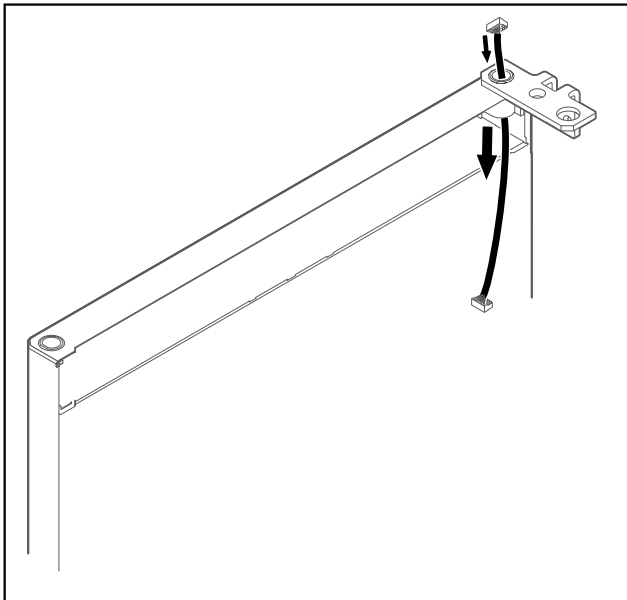

Fig. 43

- ▶ Carefully push the cable through.

NOTICE

Risk of injury if the door tips out!

- ▶ Hold the door.

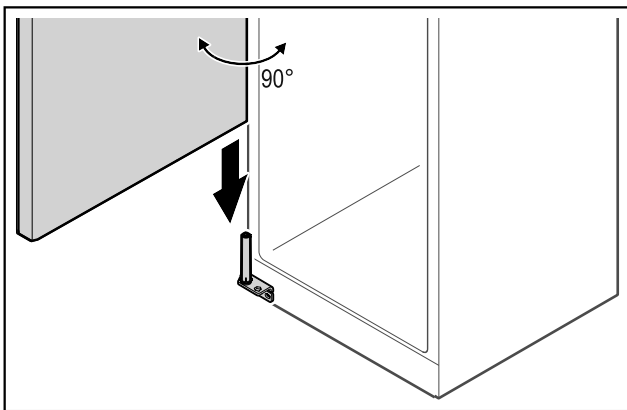

Fig. 44

- ▶ Together with a second person, lift the door from the ground.
- ▶ Carefully put the door on the closing system with the door opened at a 90° angle.

NOTICE

Material damage due to incorrect mounting!

- ▶ Do not pinch the cable when mounting the hinge.

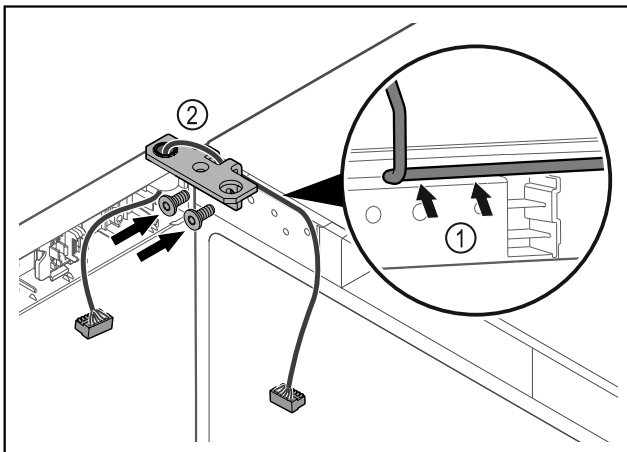

Fig. 45

- ▶ Feed the cable through the recess in the hinge and lay it carefully Fig. 45 (1).
- ▶ Screw on the hinge Fig. 45 (2).

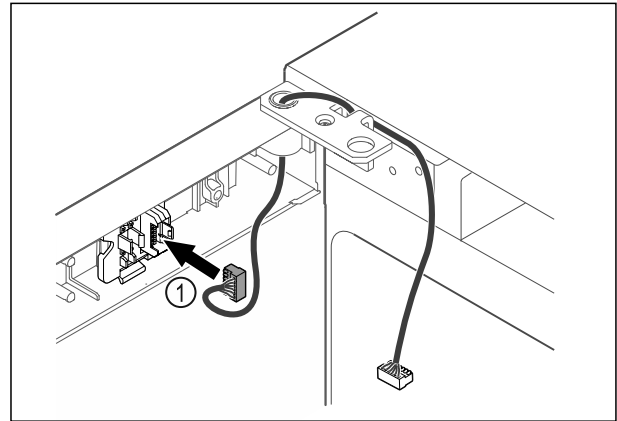

Fig. 46

- ▶ Put the plug Fig. 46 (1) in the plug holder.

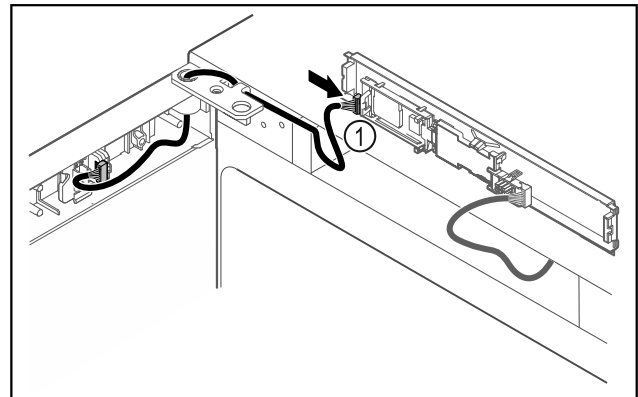

Fig. 47

- ▶ Connect the plug Fig. 47 (1) to the circuit board.

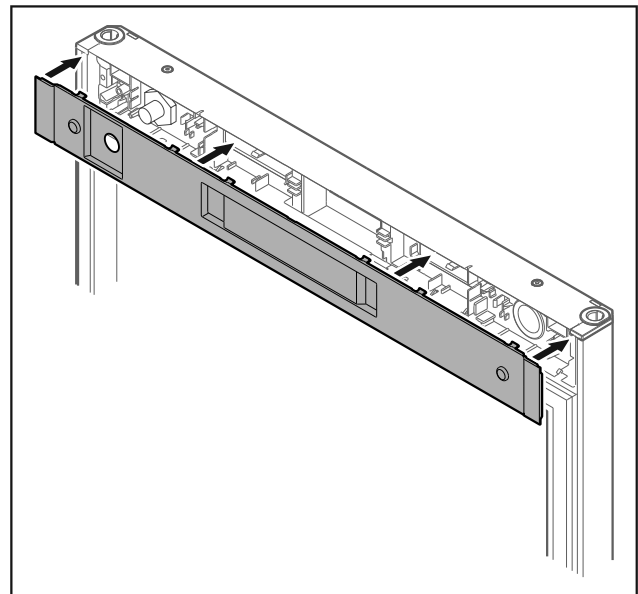

Fig. 48

- ▶ Set the cover back in place.

Putting into operation

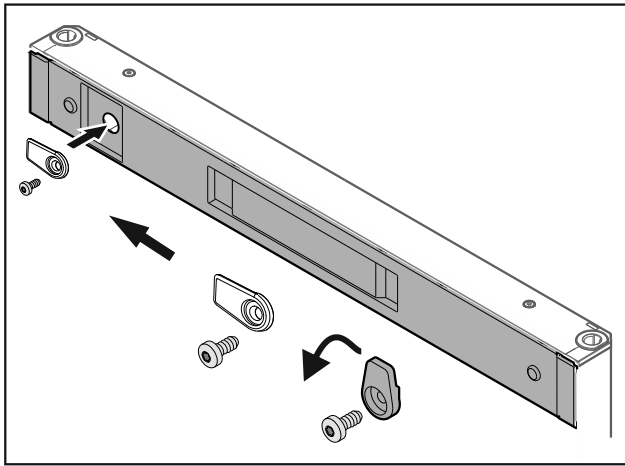

Fig. 49

- ▶ Screw on the door latch.

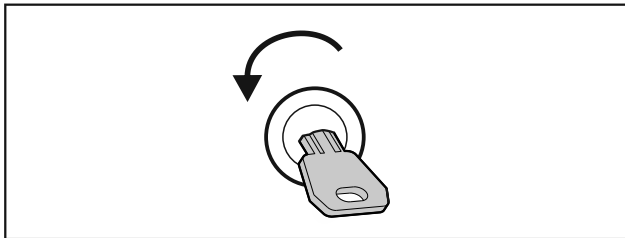

Fig. 50

- ▶ Open the door.

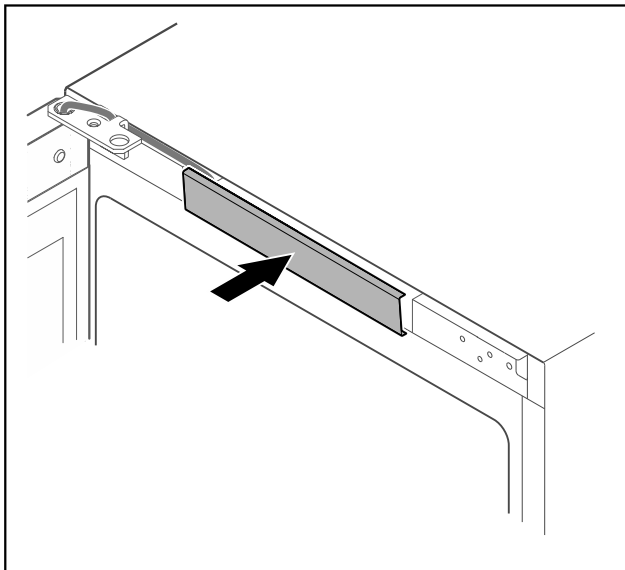

Fig. 51

- ▶ Snap in the middle cover.

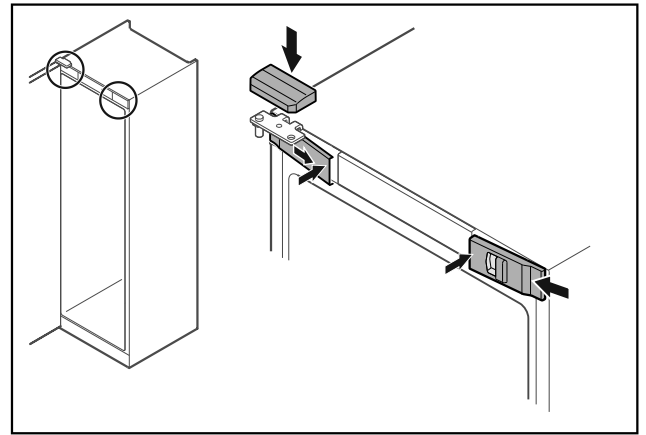

Fig. 52

- ▶ Hook in the front covers Fig. 52 (1) on the side and snap them into place on the inside.
- ▶ Snap on the top cover Fig. 52 (2) from above.
- ▶ Close the door.
- ▷ The door has now been reversed.

3.14 Aligning the door

If the door is not straight, you can adjust it on the lower hinge.

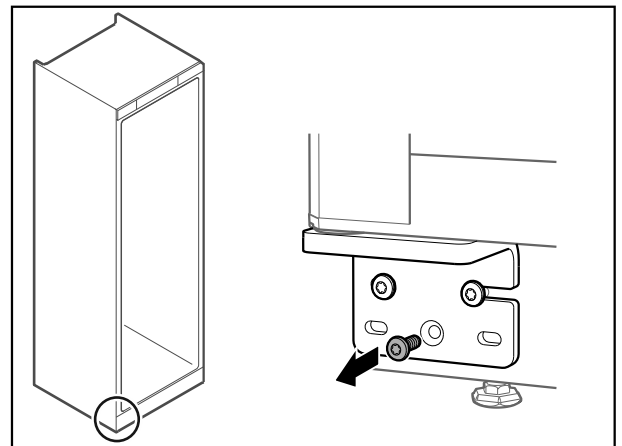

Fig. 53

- ▶ Remove the middle screw on the lower hinge.

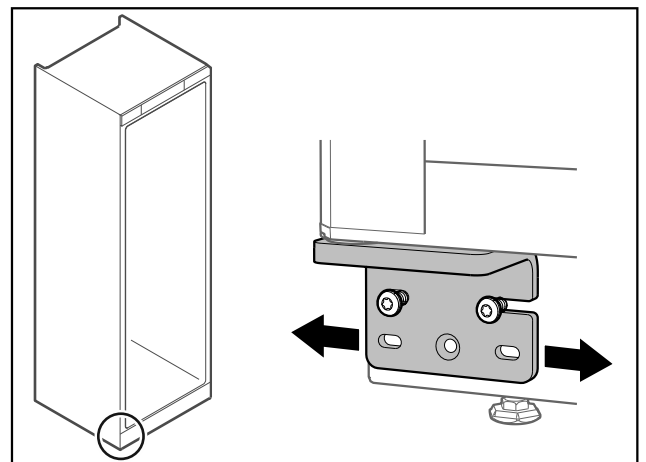

Fig. 54

- ▶ Slightly undo both screws and move the door with the hinge to the left or right.
- ▶ Fully tighten the screws (the middle screw is no longer needed).
- ▷ The door is now straight.

3.15 Connecting appliance



WARNING

Failure to connect properly
Fire hazard.

- ▶ Do not use an extension cable.
- ▶ Do not use distributor blocks.

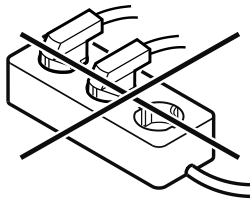

NOTICE

Failure to connect properly
Damage to the electronics.

- ▶ Do not connect the appliance to a stand-alone inverter, e.g. solar power systems and petrol generators.

Note

Only use the supplied mains cable.

Make sure the following prerequisites are met:

- The appliance is operated using **alternating current** only.
- The permitted voltage and frequency is printed on the type plate. The type plate position can be seen in the appliance overview chapter. (see 1.2 Overview of appliance and equipment)
- The socket is earthed according to the regulations and fused.
- The fuse tripping current is between 10 A and 16 A.
- The socket is easily accessible.
- ▶ Check the electrical connection.
- ▶ Insert the appliance plug into the back of the appliance. Ensure that they latch into place.
- ▶ Connect the mains plug to the power supply.
- ▷ The display switches to the standby symbol.

3.16 Switching on appliance (first use)

Make sure that the following requirements are fulfilled:

- Appliance is installed and connected.
- All adhesive strips, adhesive and protective films and transport locks are removed from inside and outside the appliance.

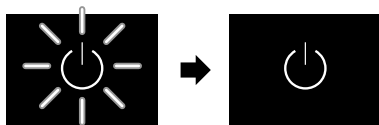

Fig. 55 Startup process

The standby symbol flashes until the startup process is complete.

The standby symbol is shown in the display.

If the appliance has been supplied with factory settings, the screen language and the date/time first need to be set when using the appliance for the first time.

The following languages are available:

- English
- Spanish
- French
- German
- Dutch
- Danish
- Italian

- Polish
- Czech
- Russian
- Chinese
- Japanese

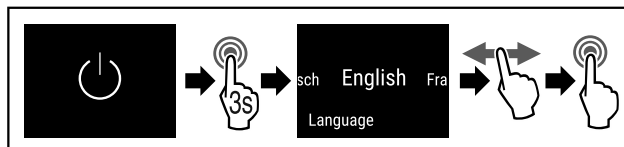

Fig. 56

- ▶ Complete steps (see Fig. 5462).
- ▷ Language is set.

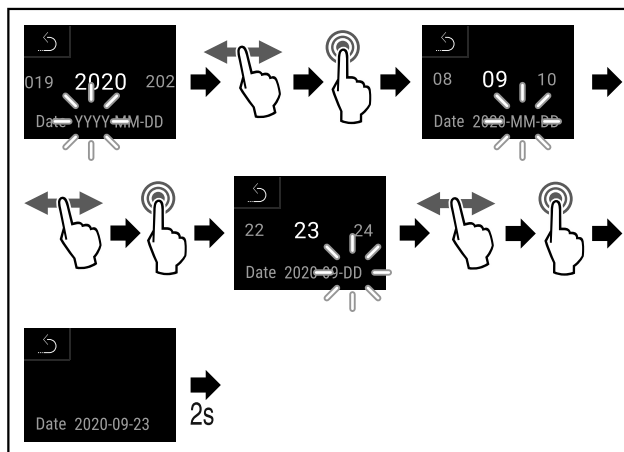

Fig. 57

- ▶ Complete steps (see Fig. 5463).
- ▷ Date is set.

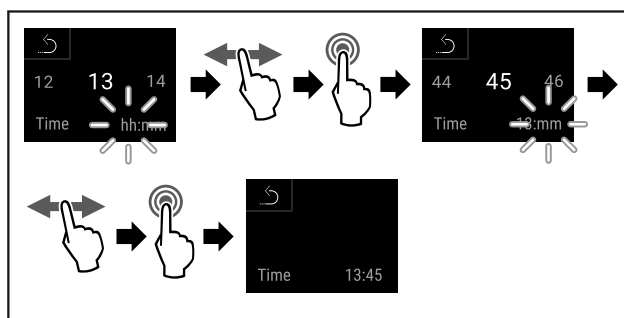

Fig. 58

- ▶ Complete steps (see Fig. 5464).
- ▷ Time is set.



Fig. 59 Status display

- ▷ The appliance is ready for operation once the temperature appears in the display.

Storage

4 Storage

4.1 Information regarding storage

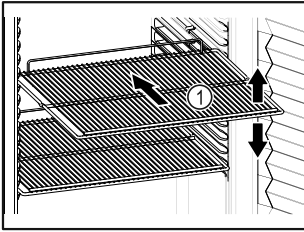

Fig. 60

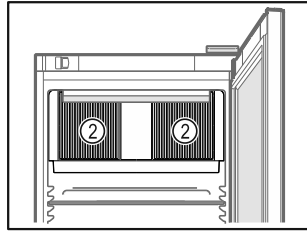



Fig. 61

When stocking observe the following:

- If there are adjustable shelves Fig. 60 (1), position them as required.
 - Observe maximum load. (see 8.1 Technical specifications)
 - Do not load appliance until storage temperature has been reached (maintain cold chain).
 - Ventilation slots Fig. 61 (2) for recirculation fan in the interior must be kept clear.
 - Items for refrigeration must not come into contact with the evaporator on the rear wall.
 - Keep liquids in closed containers.
 - Leave space when storing items for refrigeration to ensure good air circulation.
 - Do not stack refrigerated products above the indicated height. 
- This is important for free air circulation and even temperature distribution in the interior.

4.2 Storage times

The best-before date specified on the packaging should be used as the reference point for the storage time.

5 Controls

5.1 Control and display elements

The display provides a quick overview of the current appliance status, the temperature setting, the status of functions and settings as well as alarm and error messages.

It is operated by swiping or pressing the colour touch display directly.

Functions can be activated or deactivated and setting values can be changed.

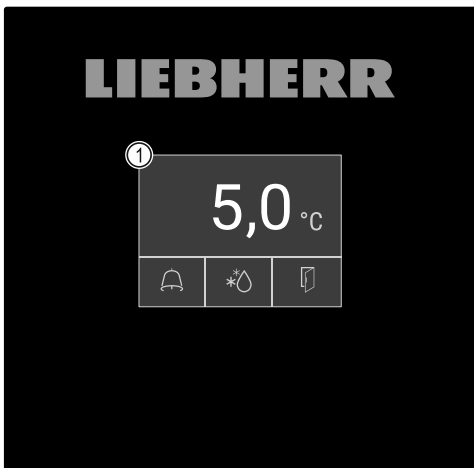

Fig. 62 Colour touch display

(1) Status display

5.1.1 Status display



Fig. 63 Status display

(1) Actual temperature
(2) Alarm status

(3) Defrosting status
(4) Door opening status









The status display is the home display.



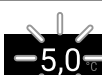

It displays the actual temperature in the centre and three symbols in the lower area. The status display may show a further range of display symbols.

You navigate from the status display to the functions and settings. (see 5.2 Navigation)

5.1.2 Display symbols









Display symbols provide information about the status of the appliance.

Symbol	Appliance status
	Standby symbol Appliance is switched off.
	Standby symbol (flashing) Appliance is starting up.
	Temperature (flashing) Target temperature not yet reached. Appliance cooling to temperature set.
	Temperature display Displays the current interior temperature
	D in the display Appliance is in Demo-Mode.
	Maintenance display (yellow) The time interval set has expired.
	Full data memory (yellow) The data memory (999 hours) is full. From now, the oldest data will be overwritten.
	Full alarm memory (yellow) The alarm memory is full. Delete individual alarms or entire memory.

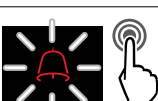
Symbol	Appliance status
	Error symbol (red) Appliance is in error state.
	Back arrow Leads to higher-level menu.
	Background (blue) Active setting or active function
	Bar (increasing) Press for 3 seconds to activate setting.
	Bar (decreasing) Press for 3 seconds to deactivate setting.

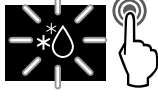
Status display symbols

The additional symbols at the bottom edge of the status display enable quick access to alarm information and details of the appliance state.

Symbol	Appliance status
	Alarm symbol (grey) Alarm archive is empty. Pressing briefly opens the alarm archive.
	Alarm symbol (white) There are confirmed alarms in the alarm archive. Pressing briefly opens the alarm archive.
	Alarm symbol (red) There are still unconfirmed alarms in the alarm archive. Pressing briefly opens the alarm archive.
	Alarm symbol (red, flashing) There is an active alarm in the archive. Pressing briefly opens the alarm archive.
	Defrosting symbol (grey) No active defrosting process.
	Defrosting symbol (white, flashing) Manual defrosting process active. Pressing briefly opens the manual defrosting. (see 5.3.20 Defrosting)
	Defrosting symbol (white) Automatic defrosting process active. Function cannot be aborted.
	Door symbol (grey) The door is closed.
	Door symbol (white) The door is open.

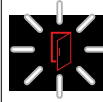
Symbol	Appliance status
	Door symbol (red, flashing) The door has been open for a prolonged period of time; the relevant warning message has been acknowledged. The symbol flashes until the door is closed.

Additional status display symbols

5.1.3 Acoustic signals

A signal sounds in the following cases:







- If a function or a value is confirmed.
- If a function or a value can either not be activated or not deactivated.
- As soon as an error occurs.
- If there is an alarm message.

The alarms can be switched on and off in the customer menu.

5.2 Navigation

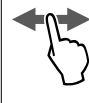
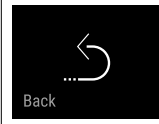
Navigate in the menu to access the individual functions. Operate directly via the colour touch display by swiping and pressing with your fingers.

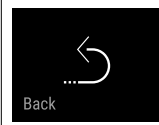
5.2.1 Navigation with the touch display

Navigation	Description
 Press briefly	Touch screen briefly with your finger. Activate/deactivate function Confirm selection. Open submenu.
 Long press	Touch screen with your finger for 3 seconds. Activate/deactivate function (increasing/decreasing bar is displayed at the top of the screen) Confirm selection. Reset appliance/values. Switch appliance on/off.
 Swipe	Swipe left or right Navigate in the menu. Search for values.
 	Touch Back symbol briefly with your finger. Jump back one level in the menu.
 	Touch Back symbol with your finger for 3 seconds. Jump back to the status display.

Controls

5.2.2 Settings menu

The following functions can be accessed through the settings menu:

- Temperature (see 5.3.3 Temperature)
- Temperature alarm (see 5.3.23 Temperature alarm)
- Door alarm (see 5.3.24 Door alarm)
- Light alarm (see 5.3.25 Light alarm)
- Alarm simulation (see 5.3.26 Alarm simulation)
- External alarm monitoring (see 5.3.28 Alarm relay)
- Calibration (see 5.3.22 Sensor calibration)
- Lighting (see 5.3.5 Lighting)
- Maintenance interval reminder (see 5.3.8 Maintenance interval reminder)
- Language (see 5.3.9 Language)
- Date and time (see 5.3.10 Date and time)
- Temperature unit (see 5.3.11 Temperature unit)
- Display brightness (see 5.3.12 Display brightness)
- Data backup (see 5.3.21 Data download / Datalogging)
- LAN connection (see 5.3.16 LAN connection) *
- WiFi connection (see 5.3.15 WiFi connection) *
- Switch off appliance (see 5.3.2 Switching appliance on and off)

Opening settings menu

- ▶ Swipe left or right until corresponding function is displayed.



Fig. 64

- ▶ Complete steps (see Fig. 5470) .
- or-
- ▶ Enter access protection PIN code for settings menu. (see 5.3.6 Settings menu access protection)
- ▷ The settings menu is opened. From here you can access all of the functions named above.

Settings menu access protection

(see 5.3.6 Settings menu access protection)

5.2.3 Customer menu

The customer menu makes it possible to call up the following hidden information and settings by entering the numerical code **151**:

- Operating hours (see 5.3.18 Operating hours)
- Software version (see 5.3.19 Software)
- Settings menu access protection (see 5.3.6 Settings menu access protection)
- Change code for settings menu access protection. (see 5.3.7 Access codes)
- Alarm sounds (see 5.3.13 Alarm Sound)
- Confirmation sounds (see 5.3.14 Key Sound)
- Door open lighting (see 5.3.5 Lighting)
- Defrosting info (see 5.3.20 Defrosting)
- Sensor Info (see 6.2 Sensors)
- DemoMode (see 5.3.29 DemoMode)
- Factory reset (see 5.3.30 Factory reset)

Opening customer menu

- ▶ Call up settings menu. (see 5.2 Navigation)
- ▶ Swipe left or right until corresponding function is displayed.

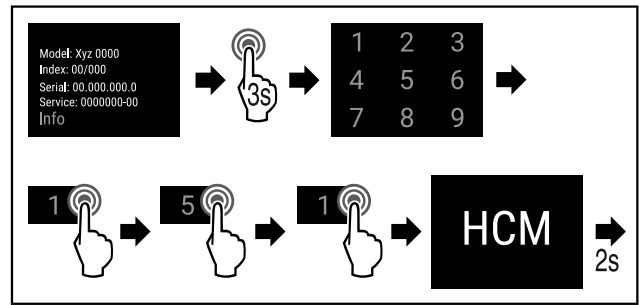

Fig. 65

- ▶ Complete steps (see Fig. 5471) .
- ▷ The hidden customer menu is opened. From here you can access all the specific menus.







5.2.4 General rules















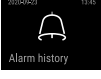

The following general rules apply in addition to the gestures available:







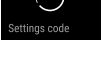

- Once a value has been selected, the selection is displayed for 2 seconds. The display then jumps back one level.
- There is a return to the status display after 10 seconds with no interaction
- If a selection is confirmed in a submenu, the display switches back to the menu.
- Activated functions and selected values are highlighted **blue**.
- Error/alarm/warning messages are highlighted **red**.
- Instructions/reminders are highlighted **yellow**.
- Long press to activate functions: increasing bar is displayed on the screen.
- Long press to deactivate functions: decreasing bar is displayed on the screen.

5.3 Functions

5.3.1 Overview of functions

-  Switch appliance on and off
-  Reset recording
-  Manually starts automatic defrosting
-  Settings
Access to this function can be blocked using a PIN code. (see 5.3.6 Settings menu access protection)
-  Info
-  Temperature setting
-  Temperature alarm

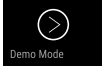
-  Door alarm
-  Light alarm
-  Alarm simulation
-  Alarm relay
-  Alarm log
-  Sensor calibration
-  Maintenance interval
-  Lighting
-  Language
-  Date/time
-  Temperature unit
-  Screen brightness
-  Data download
-  LAN *
-  WiFi *
-  System status
-  Software
-  Settings lock PIN code change

-  Activate/deactivate settings lock
-  Alarms
-  Button sounds
-  Door light
-  Defrost information
-  Sensor Info
-  DemoMode
-  Factory reset

5.3.2 Switching appliance on and off

This function makes it possible to switch the entire appliance on and off.

Switching on appliance

Without activated DemoMode:

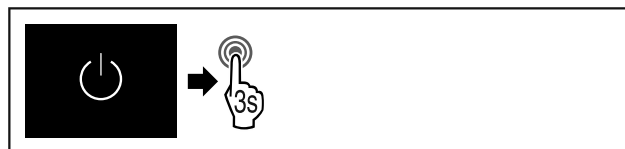

Fig. 66

► Complete steps (see Fig. 5472) .

With activated DemoMode:

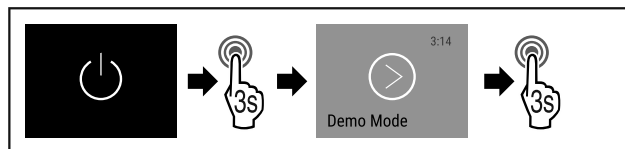

Fig. 67

► Complete steps (see Fig. 5473) .

Note

Deactivate DemoMode before countdown finishes.

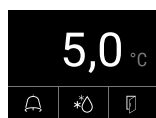

Fig. 68 Status display

► The temperature appears in the display.

Controls

Switching off appliance

- ▶ Swipe left or right on the display until the corresponding function is displayed.

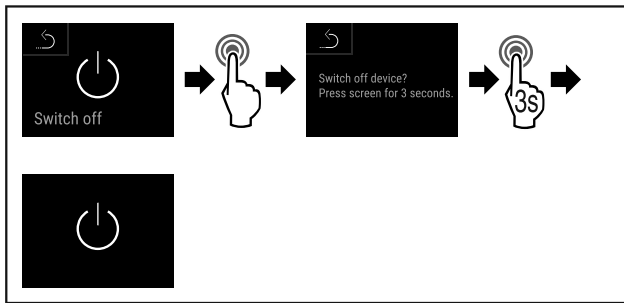

Fig. 69

- ▶ Complete steps (see Fig. 5475) .
- ▷ The standby symbol appears in the display.



5.3.3 Temperature

The temperature depends on the following factors:

- How often the door is opened
- How long the door is open for
- The room temperature of the installation site
- The type, temperature and amount of refrigerated food

Note

The temperature may differ from the temperature displayed in some areas of the interior.

At the correct temperature, cooled produce will keep for longer. This avoids disposing of food unnecessarily.

Setting temperature

The following steps describe how to increase the temperature, e.g. from 12.1 °C to 15.5 °C.

- ▶ Call up settings menu. (see 5.2 Navigation)
- ▶ Swipe left or right until corresponding function is displayed.

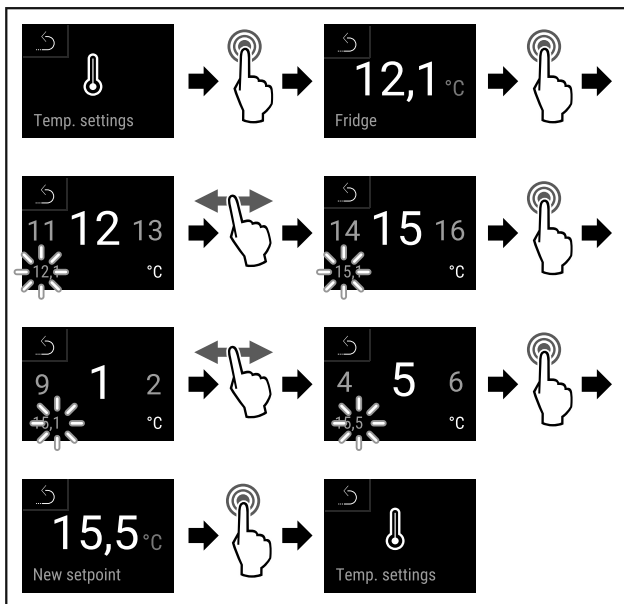

Fig. 70

- ▶ Complete steps (see Fig. 5476) .
- ▷ Temperature is set.



5.3.4 Temperature recording

The appliance displays the minimum and maximum temperatures of the interior via this function. The recording of these temperatures starts automatically after the appliance is switched on; they are recorded at one minute intervals. A note indicating that the data memory is full is displayed after 999 hours (approx. 40 days). The temperature recording should then be reset.

Note

The entire temperature history as well as alarm and service messages are also recorded independently of this function. This data can be exported and backed up on a USB storage medium. (see 5.3.21 Data download / Datalogging)

If there is an additional product sensor installed on the appliance, there is the option of selecting this sensor to display the minimum and maximum temperatures. (see 5.3.22 Sensor calibration)

Note

The temperature recording should be reset once **after reaching the set temperature** when the appliance is commissioned. (see 5.3.4.2 Resetting temperature recording) This ensures that the value for the maximum temperature is a meaningful value.

Displaying temperature recording

The temperature recording displays the length of the recording and the minimum and maximum temperatures measured during this period of time.

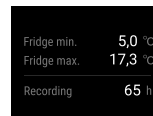

Fig. 71

- ▶ Swipe left or right until corresponding function is displayed.
- ▷ Status screen with the temperature recordings is displayed.

Resetting temperature recording

The displayed minimum and maximum temperatures can be reset at any time. This deletes the displayed values and the recording interval starts again.

- ▶ Swipe left or right until corresponding function is displayed.

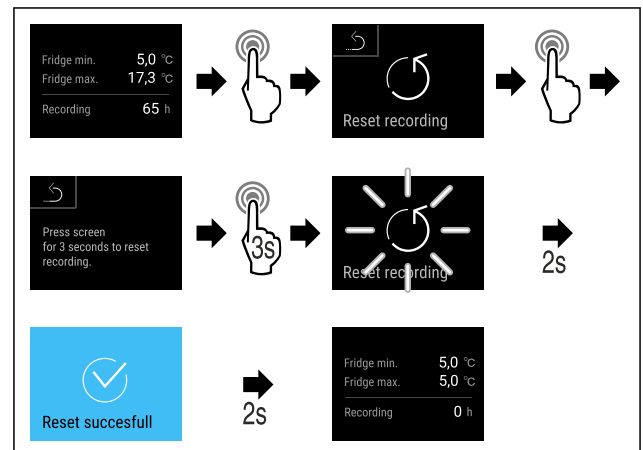

Fig. 72

- ▶ Complete steps (see Fig. 5478) .
- ▷ Temperature recording is reset.

5.3.5 Lighting



The appliance is fitted with interior lighting.

You can keep the interior lighting on continuously. (see 5.3.5.1 Switching on lighting*) *

When you open the appliance door, the interior lighting switches on. You can also deactivate this function. (see 5.3.5.3 Switching off the lighting when opening the door)

Switching on lighting*

- ▶ Call up settings menu. (see 5.2 Navigation)
- ▶ Swipe left or right until corresponding function is displayed.

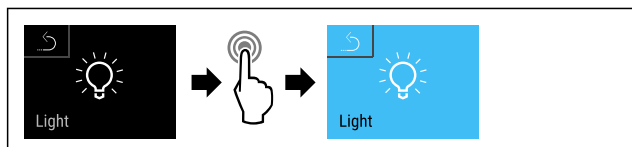

Fig. 73

- ▶ Complete steps (see Fig. 5479) .
- ▷ Lighting is switched on.

Switching off lighting*

- ▶ Call up settings menu. (see 5.2 Navigation)
- ▶ Swipe left or right until corresponding function is displayed.

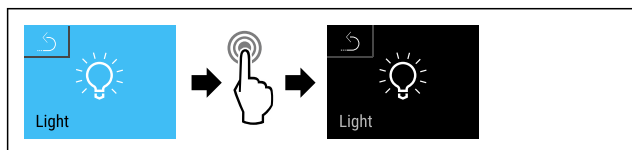

Fig. 74

- ▶ Complete steps (see Fig. 5480) .
- ▷ Lighting is switched off.

Switching off the lighting when opening the door

- ▶ Call up customer menu. (see 5.2 Navigation)
- ▶ Swipe left or right until corresponding function is displayed.

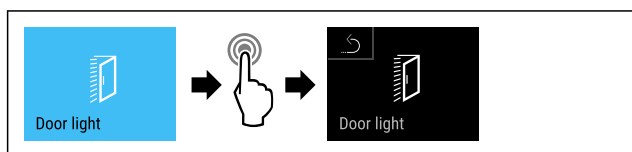

Fig. 75

- ▶ Complete the steps (see Fig. 5481) .
- ▷ The lighting is switched off when the door is opened.

Switching on the lighting when opening the door

- ▶ Call up customer menu. (see 5.2 Navigation)
- ▶ Swipe left or right until corresponding function is displayed.

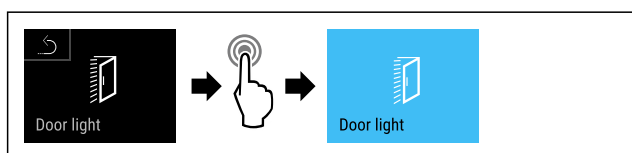

Fig. 76

- ▶ Complete the steps (see Fig. 5482) .
- ▷ The lighting is switched on when the door is opened.

5.3.6 Settings menu access protection



This function enables the settings menu access protection via a four-digit PIN code.

Application:

- Prevent settings and functions being changed unintentionally.
- Prevent appliance being switched off unintentionally.
- Prevent temperature being set unintentionally.

Activating the settings menu access protection

Note

- ▶ In the following example, the factory-set PIN code: **1 1 1 1** is used.

- ▶ Call up customer menu. (see 5.2 Navigation)
- ▶ Swipe left or right until corresponding function is displayed.

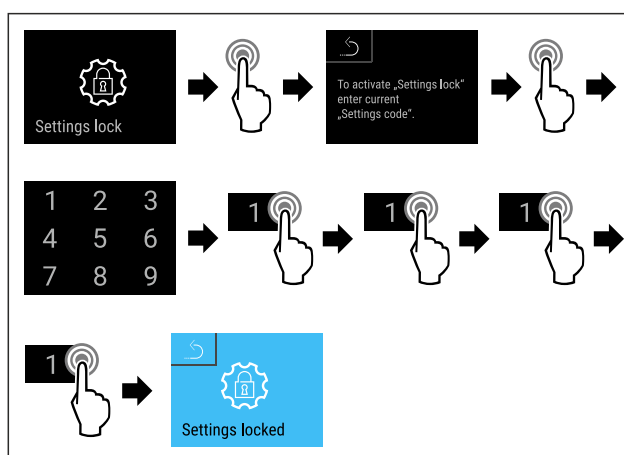

Fig. 77

- ▶ Complete steps (see Fig. 5483) .
- ▷ Settings menu access protection is activated.

Changing the access protection PIN code for the settings menu

(see 5.3.7 Access codes)

Deactivating the settings menu access protection

Note

- ▶ In the following example, the factory-set PIN code: **1 1 1 1** is used.

- ▶ Call up customer menu. (see 5.2 Navigation)
- ▶ Swipe left or right until corresponding function is displayed.

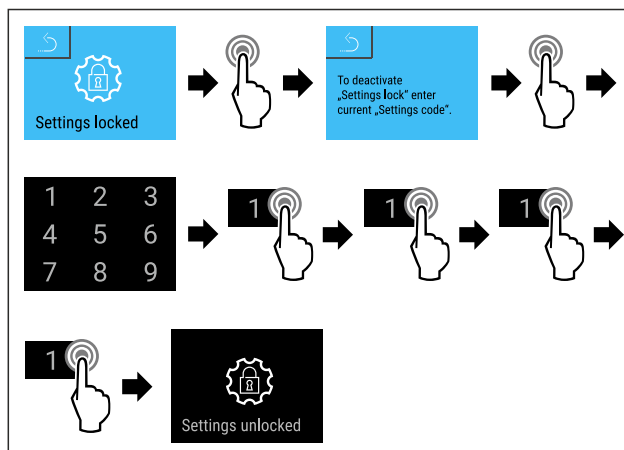

Controls

Fig. 78

- ▶ Complete steps (see Fig. 5484).
- ▷ Settings menu access protection is deactivated.

Opening protected settings menu

If the settings menu access protection is active, it is necessary to enter the PIN code to open the settings menu. The settings menu remains unlocked for 20 minutes after entering the correct PIN code.

Note

- ▶ In the following example, the PIN code is: **2 3 4 5**.

Access protection for the settings menu must be active.

- ▶ Swipe left or right until corresponding function is displayed.

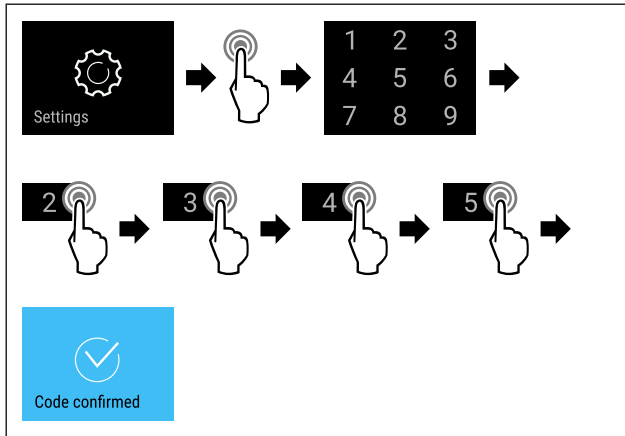

Fig. 79

- ▶ Complete steps (see Fig. 5485). Enter PIN code.
- ▷ The PIN code is correct.
- ▷ The settings menu opens.

5.3.7 Access codes

Various settings are possible.

Application:

- Changing the setting code.
- Resetting the setting code.



Settings menu access protection

Changing the settings code

This setting allows the setting code for settings menu access protection to be changed.

The setting is made in three stages:

- Entering the old settings code
- Entering the new settings code
- Confirming the new settings code

Note

- ▶ In the following example, the default factory-set settings code **1 1 1 1** is changed.
- ▶ The new settings code is: **2 3 4 5**

- ▶ Call up customer menu. (see 5.2 Navigation)
- ▶ **The settings menu access protection must be active.** (see 5.3.6 Settings menu access protection)
- ▶ Swipe left or right until corresponding function is displayed.

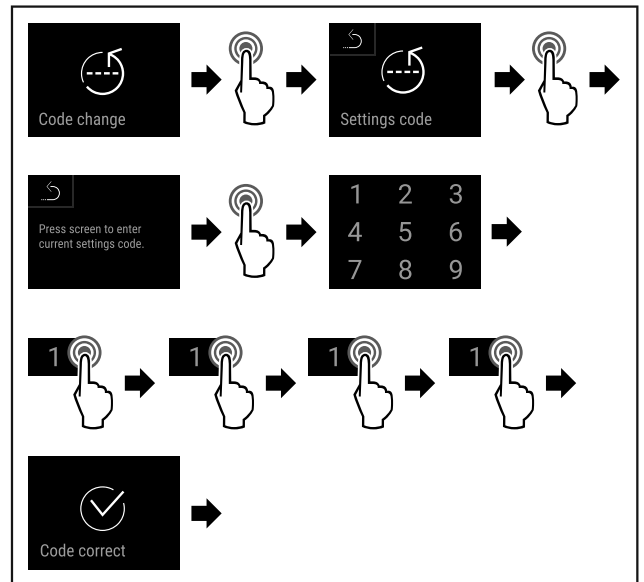

Fig. 80

- ▶ Complete steps (see Fig. 5486).
- ▷ Entry of the old settings code successful.

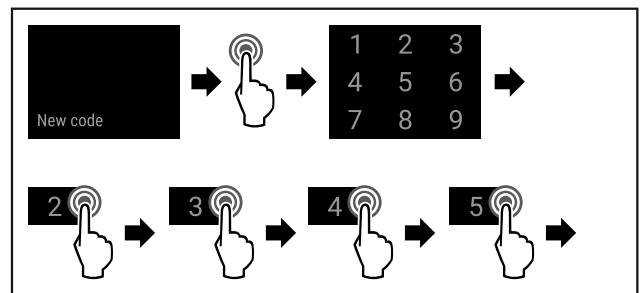

Fig. 81

- ▶ Complete steps (see Fig. 5487).
- ▷ Entry of the new settings code successful.

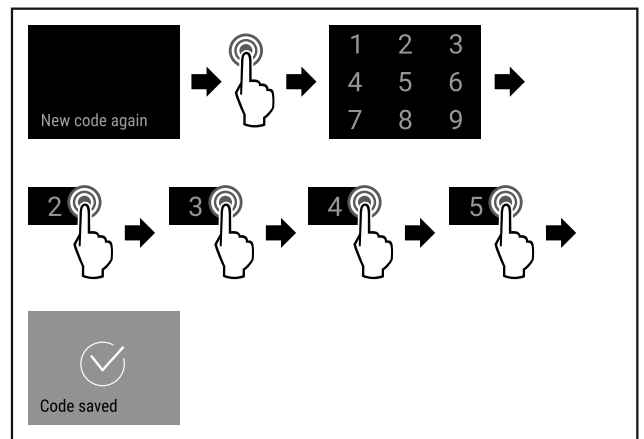

Fig. 82

- ▶ Complete steps (see Fig. 5488).
- ▷ Confirmation of the new settings code successful.
- ▷ The settings code has been changed.

Resetting the setting code

The setting code for the settings menu access protection has been forgotten or is not known.

- ▶ Reset appliance to factory settings (see 5.3.30 Factory reset).
- ▷ The appliance is reset to the original settings.
- ▷ The factory-set setting code is: **1 1 1 1**

5.3.8 Maintenance interval reminder



Setting for the time interval after which a maintenance reminder is issued.

The following values can be set:

- 7 days
- 14 days
- 30 days
- 60 days
- 90 days
- 180 days
- 360 days
- 720 days
- 1080 days
- Off

Setting maintenance interval reminder

The following steps describe how the maintenance interval is set.

- ▶ Call up settings menu. (see 5.2 Navigation)
- ▶ Swipe left or right until corresponding function is displayed.

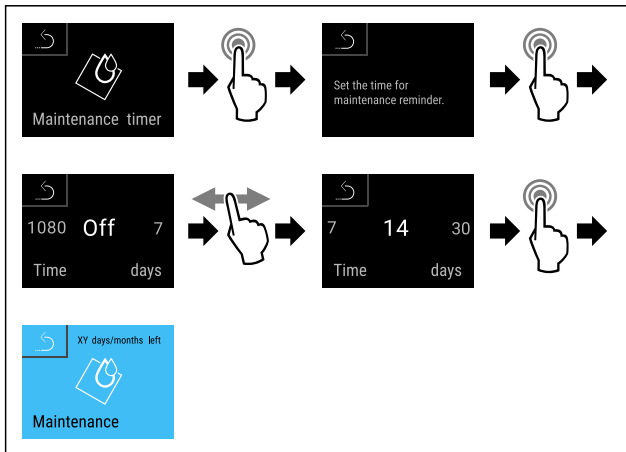

Fig. 83

- ▶ Complete steps (see Fig. 5489) .
- ▷ The time interval, after which the maintenance reminder is issued, is set.
- ▷ The remaining time is displayed.



5.3.9 Language

This setting allows the display language to be set.

Setting language

- ▶ Call up settings menu. (see 5.2 Navigation)
- ▶ Swipe left or right until corresponding function is displayed.

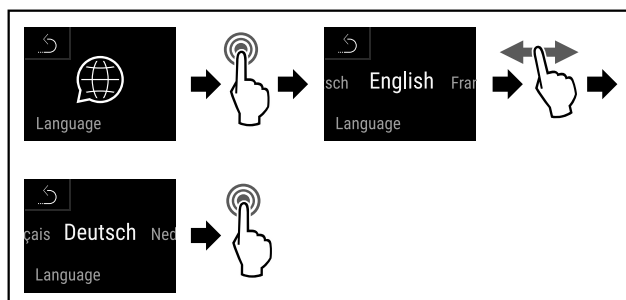

Fig. 84

- ▶ Complete steps (see Fig. 5490) .
- ▷ The selected language is set.



5.3.10 Date and time

This setting makes it possible to set the date and time.

Setting date and time

- ▶ Call up settings menu. (see 5.2 Navigation)
- ▶ Swipe left or right until corresponding function is displayed.

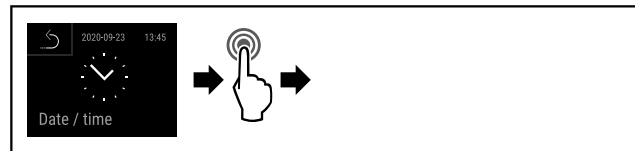

Fig. 85

- ▶ Complete steps (see Fig. 5491) .

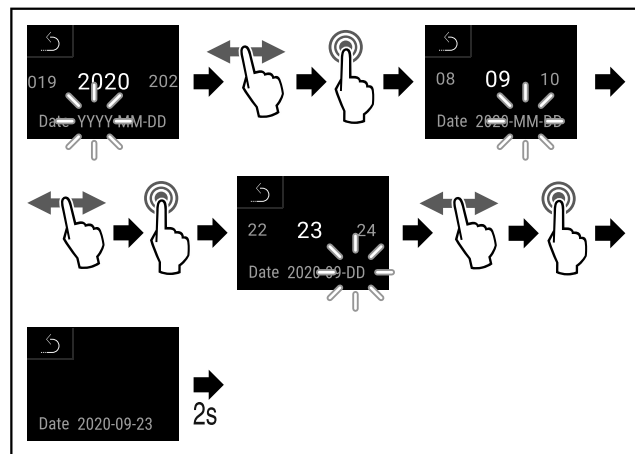

Fig. 86

- ▶ Complete steps (see Fig. 5492) .
- ▷ Date has been set.

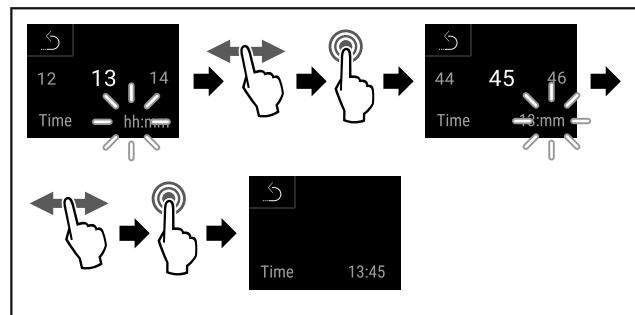

Fig. 87

- ▶ Complete steps (see Fig. 5493) .
- ▷ Time has been set.



5.3.11 Temperature unit

This setting allows the temperature unit to be changed between degrees Celsius and Fahrenheit.

Setting temperature unit

The example shows how you change the temperature unit from degrees Celsius to Fahrenheit.

- ▶ Call up settings menu. (see 5.2 Navigation)

Controls

- ▶ Swipe left or right until corresponding function is displayed.

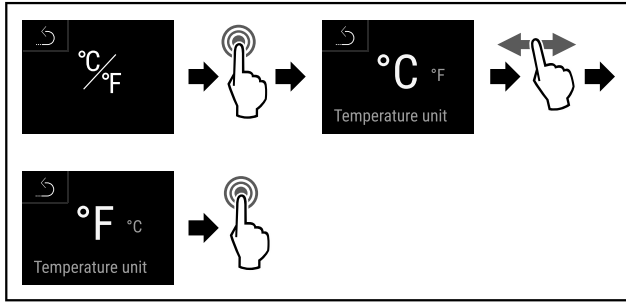

Fig. 88

- ▶ Complete steps (see Fig. 5494).
- ▷ The temperature unit is set as Fahrenheit.

5.3.12 Display brightness



This setting allows the display brightness to be adjusted incrementally.

The following brightness values can be set:

- 40%
- 60%
- 80%
- 100% (default)

Setting display brightness

The following steps describe how to reduce the display brightness, e.g. from 100 % to 40 %.

- ▶ Call up settings menu. (see 5.2 Navigation)
- ▶ Tap navigation arrow repeatedly until corresponding function is displayed.

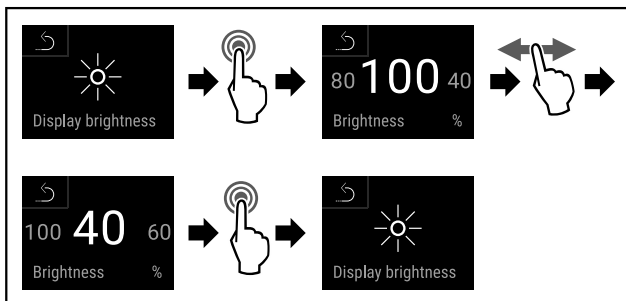

Fig. 89

- ▶ Complete steps (see Fig. 5495).
- ▷ Display brightness changes accordingly.

5.3.13 Alarm Sound



This function enables all alarm sounds, such as door alarms, to be switched on and off.

Activating Alarm Sound

- ▶ Call up customer menu. (see 5.2 Navigation)
- ▶ Swipe left or right until corresponding function is displayed.

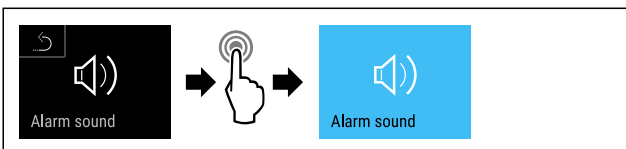

Fig. 90

- ▶ Complete steps (see Fig. 5496).
- ▷ Alarm Sound is activated.

Deactivating Alarm Sound

- ▶ Call up customer menu. (see 5.2 Navigation)
- ▶ Swipe left or right until corresponding function is displayed.

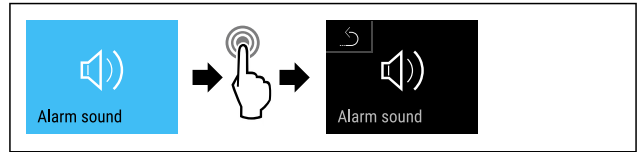

Fig. 91

- ▶ Complete steps (see Fig. 5497).
- ▷ Alarm Sound is deactivated.

5.3.14 Key Sound



This function makes it possible to switch all button sounds, confirmation sounds, and the startup sound on and off.

Activating Key Sound

- ▶ Call up customer menu. (see 5.2 Navigation)
- ▶ Swipe left or right on the display until the corresponding function is displayed.

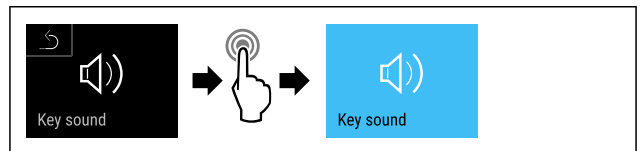

Fig. 92

- ▶ Complete steps (see Fig. 5498).
- ▷ Key Sound is activated.

Deactivating Key Sound

- ▶ Call up customer menu. (see 5.2 Navigation)

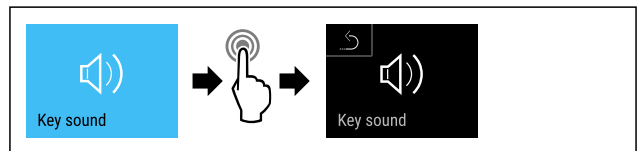

Fig. 93

- ▶ Complete steps (see Fig. 5499).
- ▷ Key Sound is deactivated.

5.3.15 WiFi connection



Note

Use of the Liebherr SmartMonitoring Dashboard at <https://smartmonitoring.liebherr.com> requires installation of a SmartModule and a commercial MyLiebherr account. When commissioning online you can register using the login data you have, or register again and create a company account.

This setting establishes a wireless connection between the appliance and the internet. The connection is controlled via the SmartModule. The appliance can be integrated via the browser-based [Liebherr SmartMonitoring Dashboard](#) and advanced options as well as customised methods relating to control, administration and monitoring can be used.

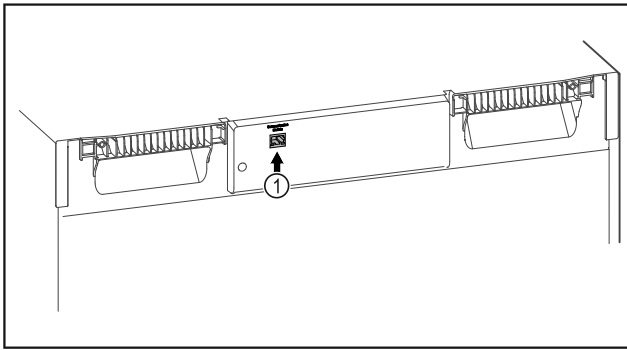

Fig. 94

Make sure that the following requirements are fulfilled:

- ☐ SmartModule Fig. 94 (1) is in use.

Establishing connection

You commission and set up your SmartModule online via the [Liebherr SmartMonitoring Dashboard](#) on your web-enabled device.



Fig. 95

- ▶ Open [Liebherr SmartMonitoring Dashboard](#). (see Fig. 5501)

On the refrigerator or freezer:

- ▶ Swipe left or right until corresponding function is displayed.



Fig. 96

- ▶ Complete the steps (see Fig. 5502).

Note

The settings menu access protection is activated. (see 5.3.6 Settings menu access protection)

- ▶ Enter the chosen PIN code. The settings menu opens.

- ▶ Swipe left or right until corresponding function is displayed.

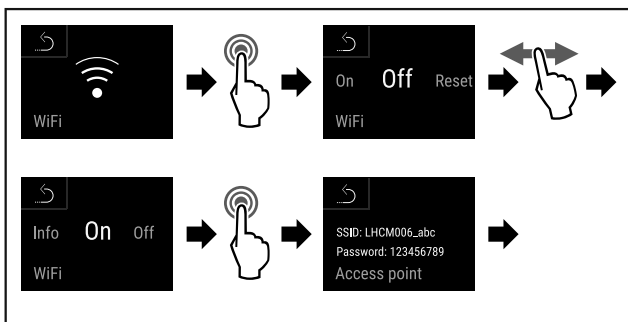

Fig. 97

- ▶ Complete the steps (see Fig. 5503).
- ▶ Continue the set-up procedure on your web-enabled device: [Liebherr SmartMonitoring Dashboard](#)

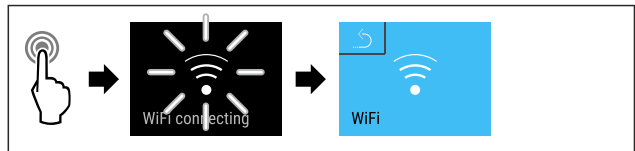

Fig. 98

- ▶ Complete the steps (see Fig. 5504).
- ▷ Connection is established: WiFi connecting appears. The symbol flashes.
- ▶ Follow the [Liebherr SmartMonitoring Dashboard](#) instructions.
- ▷ Connection is established.

Disconnecting

- ▶ Swipe left or right until corresponding function is displayed.



Fig. 99

- ▶ Complete the steps (see Fig. 5505).

Note

The settings menu access protection is activated. (see 5.3.6 Settings menu access protection)

- ▶ Enter the chosen PIN code. The settings menu opens.

- ▶ Swipe left or right until corresponding function is displayed.

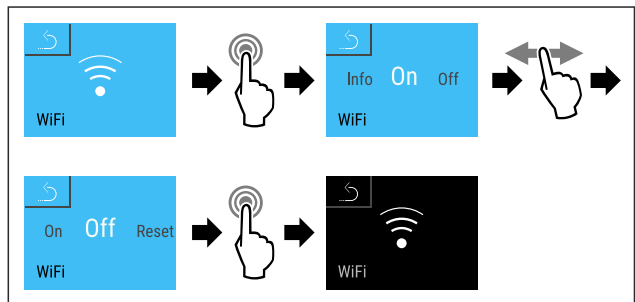

Fig. 100

- ▶ Complete the steps (see Fig. 5506).

- ▷ There is no connection.

Resetting connection

- ▶ Swipe left or right until corresponding function is displayed.



Fig. 101

- ▶ Complete the steps (see Fig. 5502).

Note

The settings menu access protection is activated. (see 5.3.6 Settings menu access protection)

- ▶ Enter the chosen PIN code. The settings menu opens.

- ▶ Swipe left or right until corresponding function is displayed.

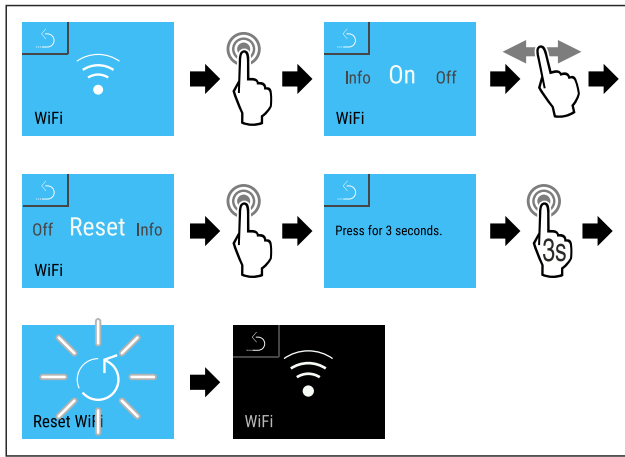

Fig. 102

- ▶ Complete the steps (see Fig. 5508) .
- ▷ The WiFi settings are restored to the factory settings.



5.3.16 LAN connection

Note

Use of the Liebherr SmartMonitoring Dashboard at <https://smartmonitoring.liebherr.com> requires installation of a SmartModule and a commercial MyLiebherr account. When commissioning online you can register using the login data you have, or register again and create a company account.

This setting establishes a wired connection between the appliance and the internet. The connection is controlled via the SmartModule. The appliance can be integrated via the browser-based [Liebherr SmartMonitoring Dashboard](#) and advanced options as well as customised methods relating to control, administration and monitoring can be used.

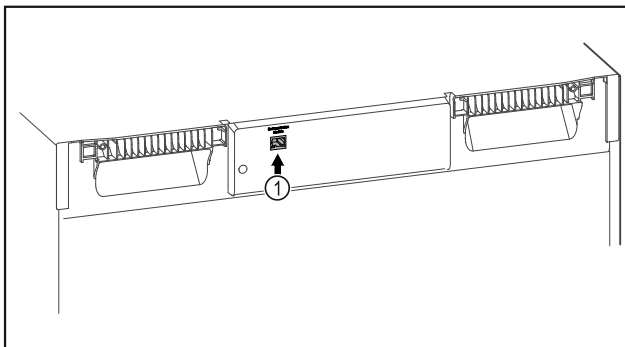

Fig. 103

Make sure that the following requirements are fulfilled:

- SmartModule Fig. 103 (1) is in use.
- A network cable is connected.

Establishing connection

You commission and set up your SmartModule online via the [Liebherr SmartMonitoring Dashboard](#) on your web-enabled device.



Fig. 104

- ▶ Open [Liebherr SmartMonitoring Dashboard](#). (see Fig. 5510)

On the refrigerator or freezer:

- ▶ Swipe left or right until corresponding function is displayed.

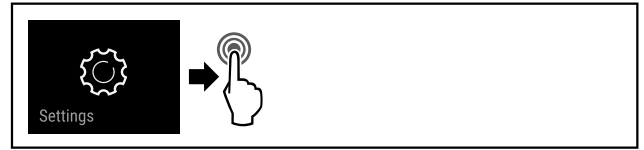

Fig. 105

- ▶ Complete the steps (see Fig. 5511) .

Note

The settings menu access protection is activated. (see 5.3.6 Settings menu access protection)

- ▶ Enter the chosen PIN code. The settings menu opens.

- ▶ Swipe left or right until corresponding function is displayed.

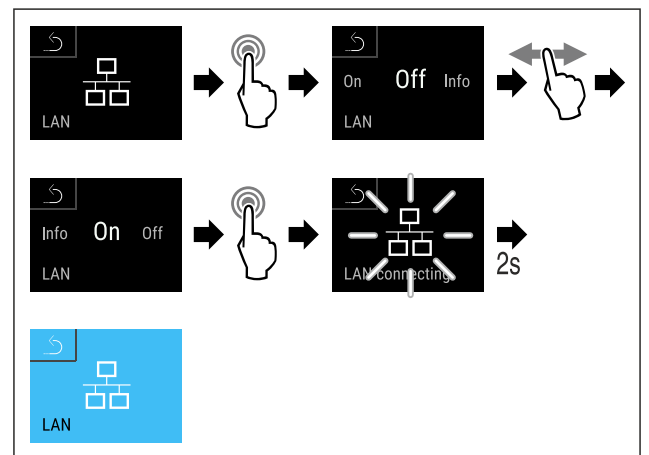

Fig. 106

- ▶ Complete the steps (see Fig. 5512) .
- ▷ Connection is established: LAN connecting appears. The symbol flashes.
- ▶ Follow the [Liebherr SmartMonitoring Dashboard](#) instructions.
- ▷ Connection is established.

Disconnecting

- ▶ Swipe left or right until corresponding function is displayed.



Fig. 107

- ▶ Complete the steps (see Fig. 5513) .

Note

The settings menu access protection is activated. (see 5.3.6 Settings menu access protection)

- ▶ Enter the chosen PIN code. The settings menu opens.

- ▶ Swipe left or right until corresponding function is displayed.

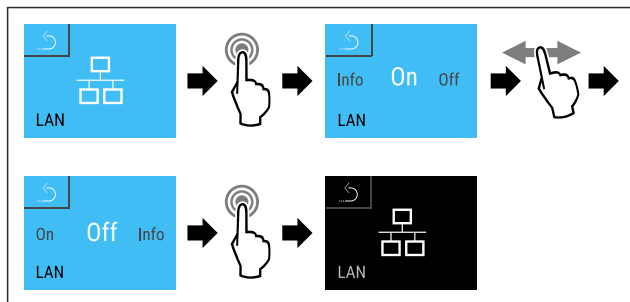

Fig. 108

- ▶ Complete the steps (see Fig. 5514) .
- ▷ There is no connection.

5.3.17 Info



This display shows the model, serial number and service number of the appliance.

Displaying Info

- ▶ Swipe left or right until the corresponding function is displayed.

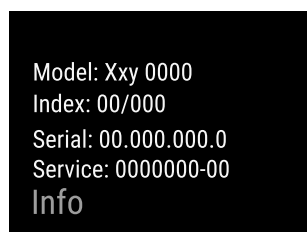
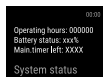

Fig. 109

- ▷ The appliance information appears.

5.3.18 Operating hours



The display shows the appliance operating hours.

Displaying operating hours

- ▶ Open customer menu .

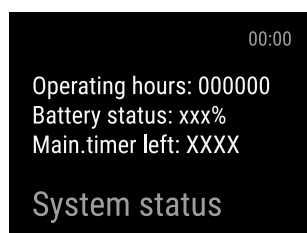

Fig. 110

- ▷ The operating hours appear.

5.3.19 Software



The display shows the software version of the appliance.

Displaying software version

- ▶ Open customer menu .
- ▶ Swipe left or right until the corresponding function is displayed.

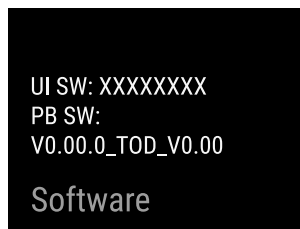

Fig. 111

- ▷ The software version is shown.

5.3.20 Defrosting



The appliance defrosts automatically in normal mode.

Application:

- If there is excessive ice in the interior, the defrosting function can be started manually.

Manually starting automatic defrosting

- ▶ Swipe left or right until corresponding function is displayed.

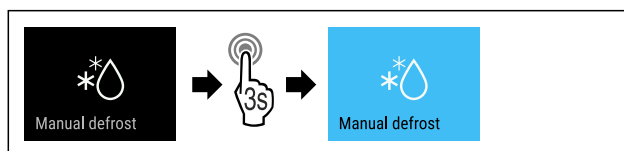

Fig. 112

- ▶ Complete steps (see Fig. 5518) .
- ▷ Automatic defrosting has been started. The appliance automatically switches back to normal mode once defrosting has finished.

Cancelling manually started defrosting

- ▶ Swipe left or right until corresponding function is displayed.

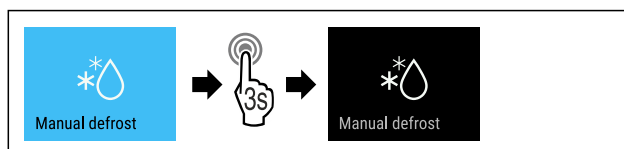

Fig. 113

- ▶ Complete steps (see Fig. 5519) .
- ▷ Manually started defrosting is cancelled. The appliance automatically switches back to normal mode.

Defrosting info



This setting adjusts the display during an automatic defrosting process.

The following display variants are available:

- **Def 1:** “Automatic defrosting process” symbol is displayed in the status screen. The temperature display is not updated and shows the last temperature before the automatic defrosting process was started.
- **Def 2:** “Automatic defrosting process” symbol is displayed in the status screen. The temperature display is updated continuously and shows the actual temperature.
- **Def 3:** The temperature display is not updated and shows the last temperature before the automatic defrosting process was started.
- **Def 4:** The temperature display is updated continuously and shows the actual temperature.



Fig. 114 “Automatic defrosting process” symbol

- ▶ Call up customer menu. (see 5.2 Navigation)
- ▶ Swipe left or right until corresponding function is displayed.

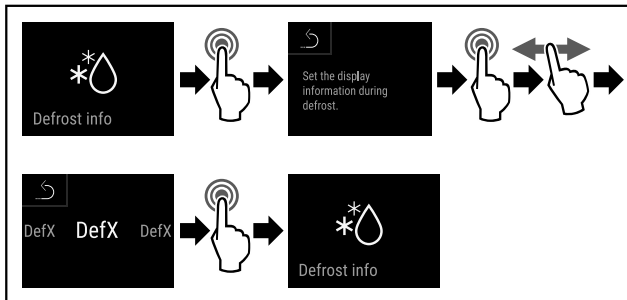

Fig. 115

- ▶ Complete steps (see Fig. 5521) .
- ▷ The desired display variant has been selected.



5.3.21 Data download / Datalogging

The appliance automatically records the entire temperature history of various sensors as well as alarm and service messages. The recording starts automatically after the appliance is switched on and records at one minute intervals. The data for the past 5 years is stored and can be downloaded onto a USB stick at any time.

The following data sets can be selected for download:

- Temperatures
- Alarms
- Service messages
- All

The selected data sets are stored in unencrypted format as text files over the entire recording period; these files have the extension „.log“.

Data download on USB stick

Note

Only USB memory sticks may be connected to the USB interface. USB hard drives are not detected.

Note

Do not remove the USB storage stick during the download procedure.

Make sure that the following requirements are fulfilled:

- USB 2.0 storage stick, FAT32 formatted.
- USB stick is connected.
- ▶ Call up settings menu. (see 5.2 Navigation)
- ▶ Swipe left or right until corresponding function is displayed.

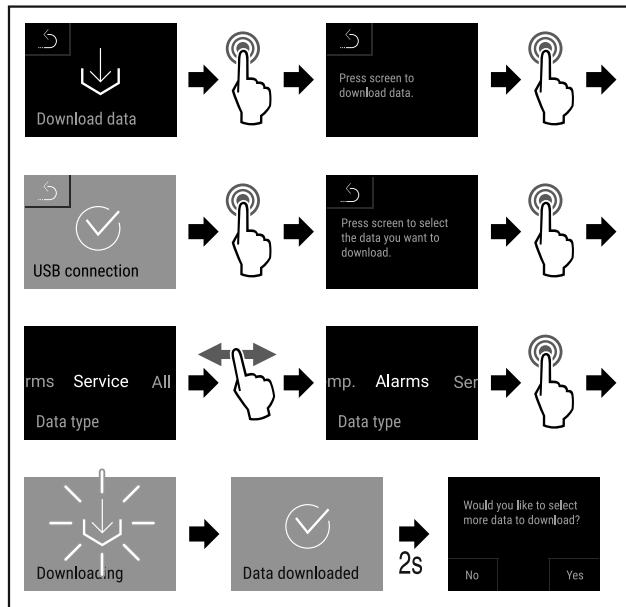

Fig. 116

- ▶ Complete steps (see Fig. 5522) .
- ▷ Successful data download on USB stick.
- ▷ It is possible to select and download further data sets.



5.3.22 Sensor calibration

The sensor calibration is used to realign differences between the displayed temperature and the actual temperature in the appliance.

Setting range for C sensor (control sensor): +/- 3 Kelvin in 0.1 Kelvin increments.

Setting range for P sensor (product sensor): +/- 9.9 Kelvin in 0.1 Kelvin increments

Calibrating sensor

- ▶ Call up settings menu. (see 5.2 Navigation)
- ▶ Swipe left or right until corresponding function is displayed.

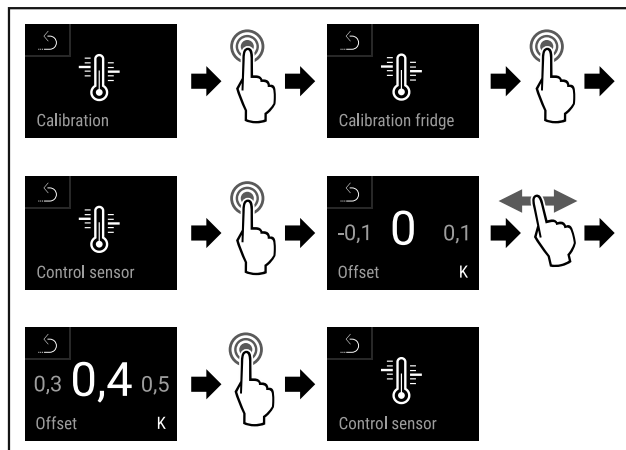

Fig. 117

- ▶ Complete steps (see Fig. 5523) .
- ▷ C sensor has been calibrated.

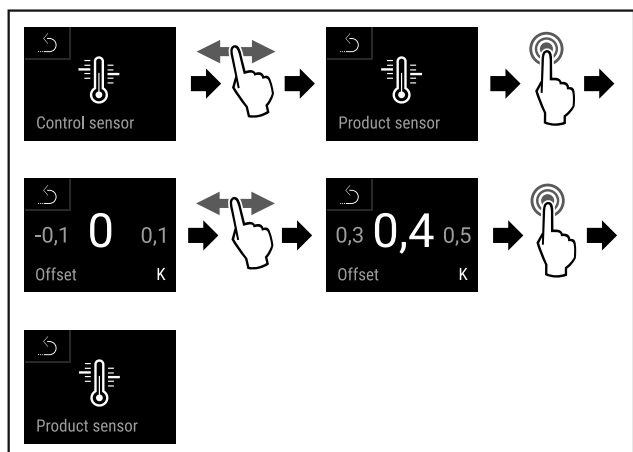

Fig. 118

- ▶ Complete steps (see Fig. 5524).
- ▷ P sensor has been calibrated.
- ▷ Sensor calibration has been completed.

5.3.23 Temperature alarm



The temperature alarm is triggered as soon as the interior temperature departs from the settable temperature range.

The following values can be set:

- Lower temperature limit in 0.1 °C increments
- Upper temperature limit in 0.1 °C increments
- Alarm delay time of between 0 and 60 minutes
- Alarm repetition frequency of between 0 and 30 minutes

Setting temperature alarm

- ▶ Call up settings menu. (see 5.2 Navigation)
- ▶ Swipe left or right until corresponding function is displayed.

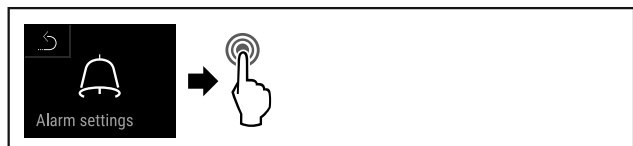

Fig. 119

- ▶ Complete steps (see Fig. 5525).
- ▶ Swipe left or right until corresponding function is displayed.

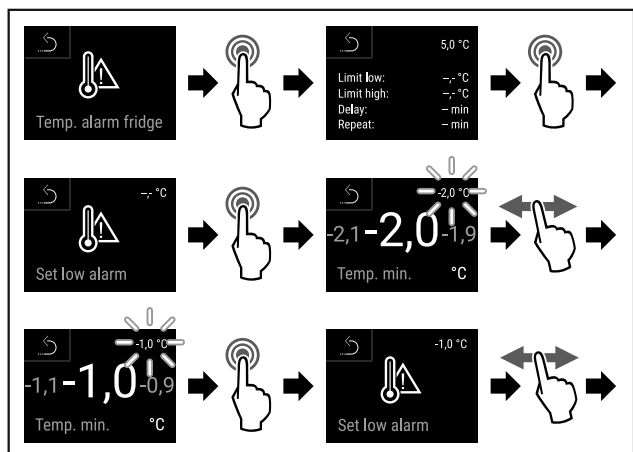

Fig. 120

- ▶ Complete steps (see Fig. 5526).
- ▷ Lower temperature limit has been set.

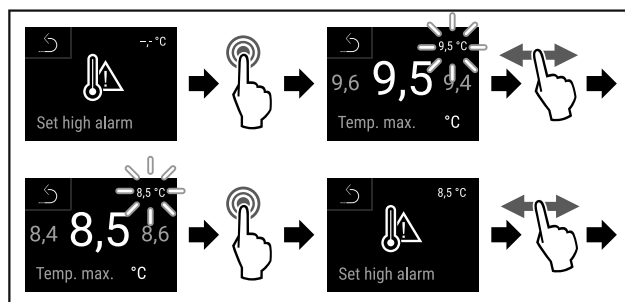

Fig. 121

- ▶ Complete steps (see Fig. 5527).
- ▷ Upper temperature limit has been set.

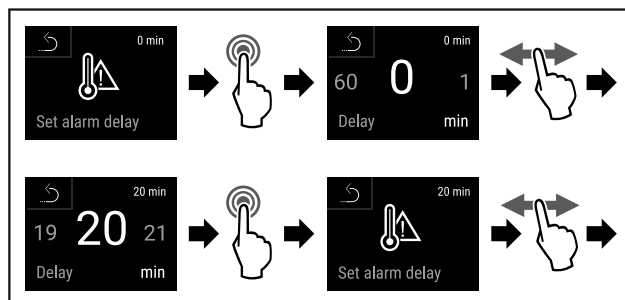

Fig. 122

- ▶ Complete steps (see Fig. 5528).
- ▷ Alarm delay time has been set.

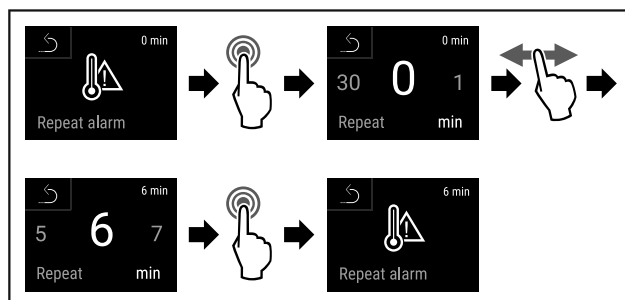

Fig. 123

- ▶ Complete steps (see Fig. 5529).
- ▷ Alarm repetition interval has been set.
- ▷ Temperature alarm has been set.

Displaying set temperature alarm values

- ▶ Call up settings menu. (see 5.2 Navigation)
- ▶ Swipe left or right until corresponding function is displayed.

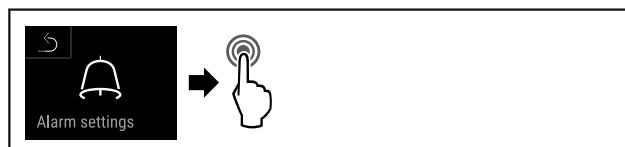

Fig. 124

- ▶ Complete steps (see Fig. 5530).
- ▶ Swipe left or right until corresponding function is displayed.

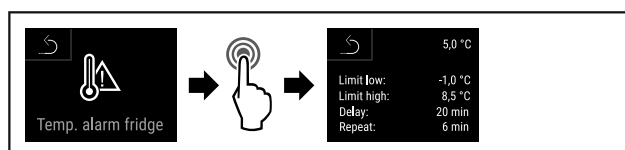

Fig. 125

- ▶ Complete steps (see Fig. 5531).
- ▷ Set temperature alarm values are displayed.

5.3.24 Door alarm



Setting the time interval after which the door alarm sounds when the door is opened.

The following values can be set:

- 15 seconds
- 30 seconds
- 60 seconds
- 90 seconds
- 120 seconds
- 150 seconds
- 180 seconds
- Off

Setting door alarm

The following steps describe how you set the time interval before the door alarm sounds.

- ▶ Call up settings menu. (see 5.2 Navigation)
- ▶ Swipe left or right until corresponding function is displayed.

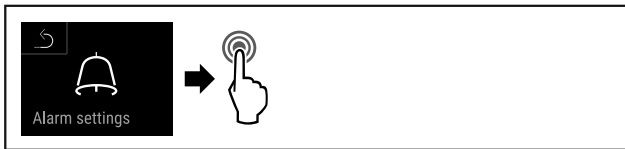

Fig. 126

- ▶ Complete steps (see Fig. 5532).
- ▶ Swipe left or right until corresponding function is displayed.

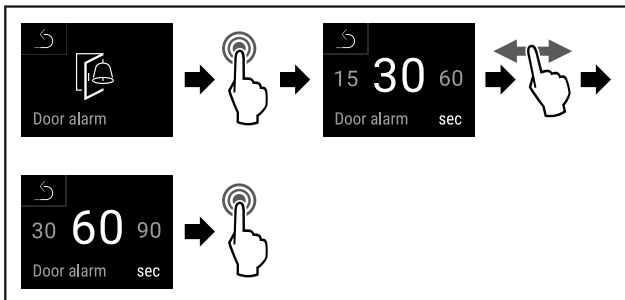

Fig. 127

- ▶ Complete steps (see Fig. 5533).
- ▷ The door alarm is set.

Deactivating door alarm

The following steps describe how you deactivate the door alarm.

- ▶ Call up settings menu. (see 5.2 Navigation)
- ▶ Swipe left or right until corresponding function is displayed.

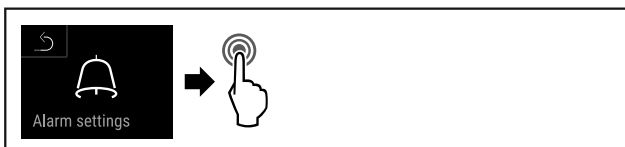

Fig. 128

- ▶ Complete steps (see Fig. 5534).
- ▶ Swipe left or right until corresponding function is displayed.

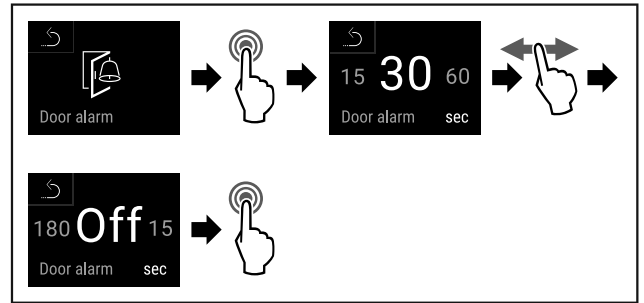
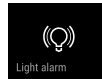

Fig. 129

- ▶ Complete steps (see Fig. 5535).
- ▷ The door alarm is deactivated.

5.3.25 Light alarm



This setting allows the visual alarm messages in the display to also be emphasised by flashing appliance lighting.

Activating light alarm

- ▶ Call up settings menu. (see 5.2 Navigation)
- ▶ Swipe left or right until corresponding function is displayed.

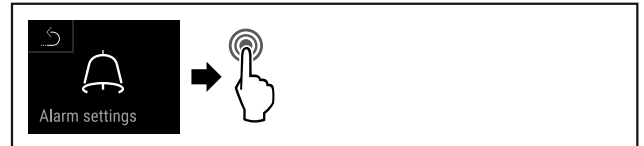

Fig. 130

- ▶ Complete steps (see Fig. 5536).
- ▶ Swipe left or right until corresponding function is displayed.

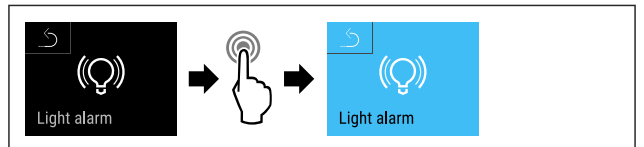

Fig. 131

- ▶ Complete steps (see Fig. 5537).
- ▷ The light alarm is activated.

Deactivating light alarm

- ▶ Call up settings menu. (see 5.2 Navigation)
- ▶ Swipe left or right until corresponding function is displayed.

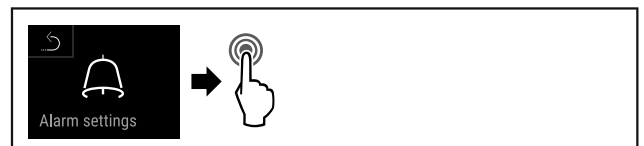

Fig. 132

- ▶ Complete steps (see Fig. 5538).
- ▶ Swipe left or right until corresponding function is displayed.

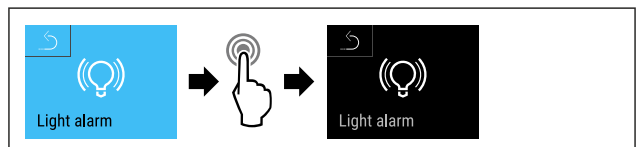

Fig. 133

- ▶ Complete steps (see Fig. 5539).
- ▷ The light alarm is activated.

5.3.26 Alarm simulation



This setting makes it possible to simulate a change in the appliance temperature to check the function of any safety devices that may be connected.

Starting alarm simulation

- ▶ Call up settings menu. (see 5.2 Navigation)
- ▶ Swipe left or right until corresponding function is displayed.

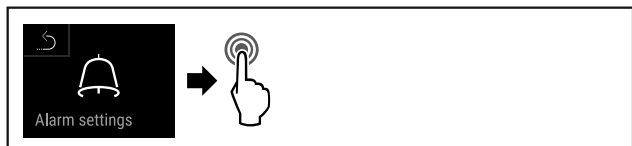

Fig. 134

- ▶ Complete steps (see Fig. 5540).
- ▶ Swipe left or right until corresponding function is displayed.

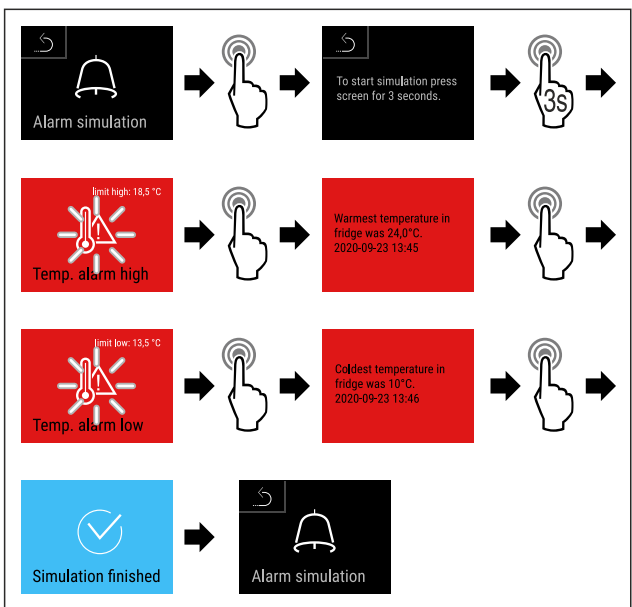
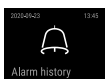

Fig. 135

- ▶ Complete steps (see Fig. 5541).
- ▷ The simulation has been performed.
- ▷ Connected safety devices should have triggered.

5.3.27 Alarm log



This setting makes it possible to query and delete the last 10 alarms that have occurred on the device.

The following is displayed:

- Current date and time
- Active alarms (red).
- Past alarms, which have not yet been queried, are shown as **unconfirmed (red)**. Confirmation is given by swiping to the next error.
- Alarms, which have been queried, are shown as **confirmed**.
- Deletion of all alarms (including active and unconfirmed alarms).

Displaying alarm log and deleting an alarm

- ▶ Swipe left or right until corresponding function is displayed.

-or-

- ▶ Via the display symbol at the bottom edge of the status display.

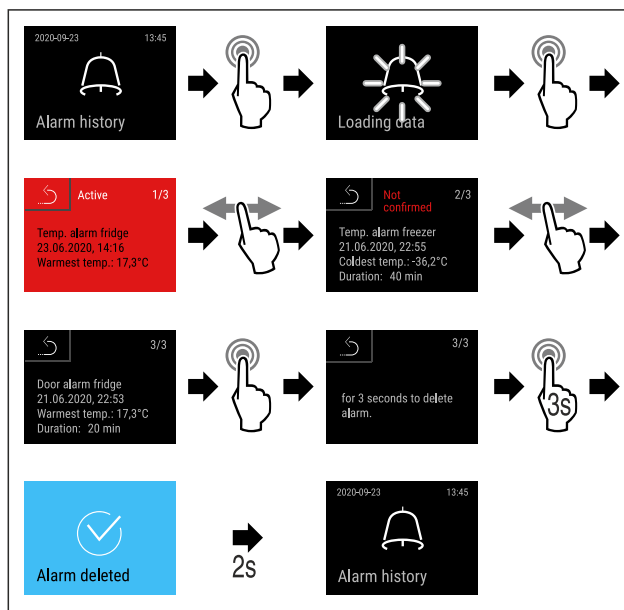

Fig. 136

- ▶ Complete steps (see Fig. 5542).
- ▷ The querying and deletion of an alarm has been performed.

Displaying alarm log and deleting all alarms

- ▶ Swipe left or right until corresponding function is displayed.

-or-

- ▶ Via the display symbol at the bottom edge of the status display.

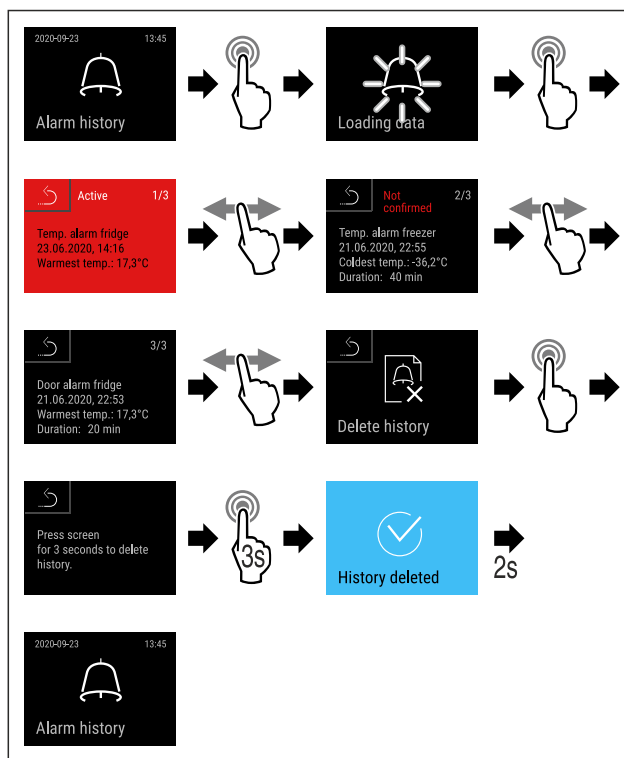

Fig. 137

- ▶ Complete steps (see Fig. 5543).
- ▷ The querying and deletion of all alarms has been performed.



5.3.28 Alarm relay

This setting makes it possible to relay one or more alarms to an external alarm source connected to the appliance.

The following settings can be selected:

- Alarm type:
 - Door alarm
 - Temperature alarm
 - Door alarm and temperature alarm
 - All
- Confirm:
 - **Yes:** Alarm is stopped on the appliance and on the externally connected appliance.
 - **No:** Alarm is acknowledged on the appliance and remains active on the external appliance until the error is remedied.
- Update (only visible if “Yes” is selected in response to Confirm):
 - **Yes:** Alarm is recurring according to the set time. (see 5.3.24 Door alarm)
 - **No:** Alarm is continuously acknowledged.

Activating alarm relay

- ▶ Call up settings menu. (see 5.2 Navigation)
- ▶ Swipe left or right until corresponding function is displayed.

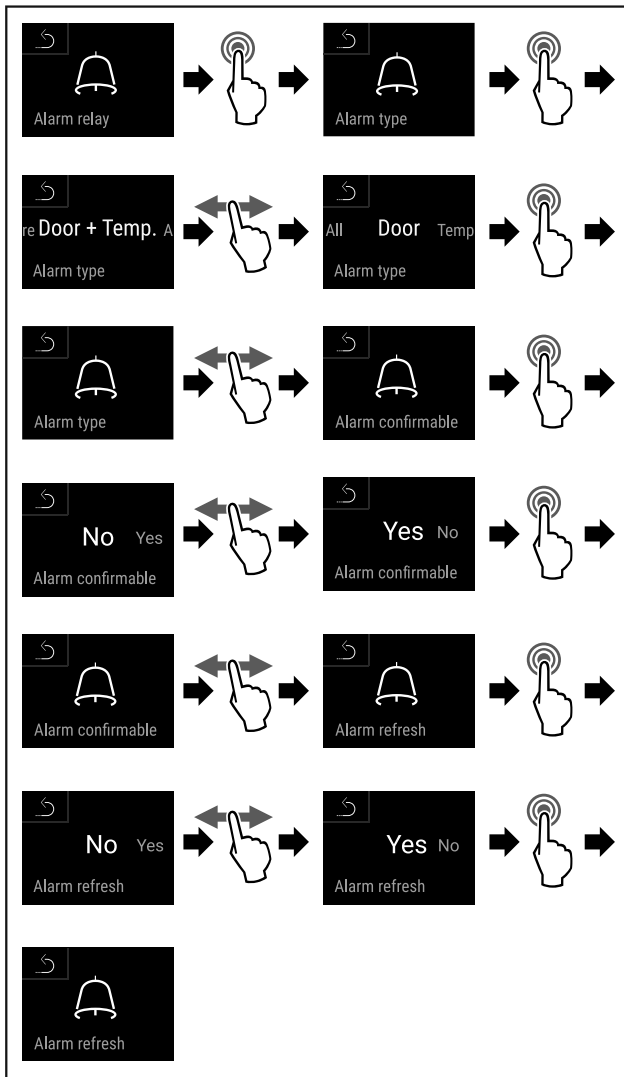

Fig. 138

- ▶ Complete steps (see Fig. 5544) .
- ▷ The alarm relay has been set.



5.3.29 DemoMode

If the appliance is in DemoMode all refrigeration functions are deactivated. This is useful for example for demonstrations.

Activating DemoMode

- ▶ Call up customer menu.
- ▶ Swipe left or right until corresponding function is displayed.

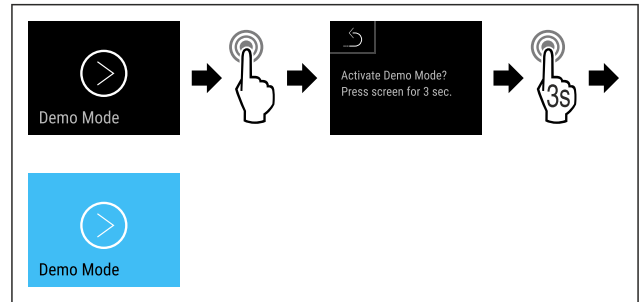

Fig. 139

- ▶ Complete steps (see Fig. 5545) .

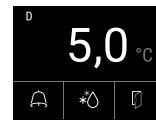

Fig. 140 Status display

- ▷ DemoMode is activated.
- ▷ The status display is shown with a “D” in the top left.

Deactivating DemoMode

- ▶ Call up customer menu.
- ▶ Swipe left or right until corresponding function is displayed.

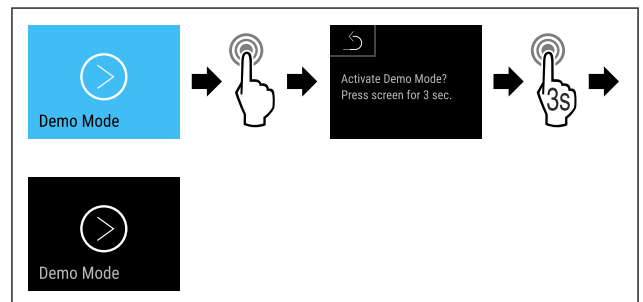

Fig. 141

- ▶ Complete steps (see Fig. 5547) .



Fig. 142 Status display

- ▷ DemoMode is deactivated.
- ▷ The status display appears.



5.3.30 Factory reset

This function resets the appliance to the factory settings. All settings made to this point are reset to their original values.

Performing factory reset

- ▶ Call up customer menu.
- ▶ Swipe left or right until corresponding function is displayed.

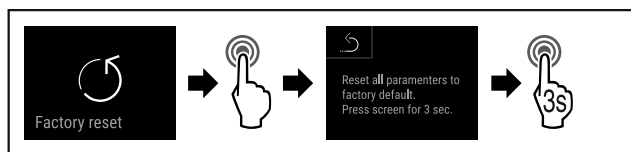



Fig. 143

- ▶ Complete steps (see Fig. 5549) .
- ▷ Factory reset is completed.
- ▷ Appliance restarts.





5.4 Message

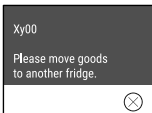
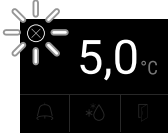
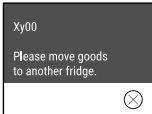

5.4.1 Warnings

Warnings are issued by means of an acoustic signal and visually via a symbol on the display. The signal gets louder until the warning is acknowledged.

Message (red)	Cause	Remedy
 <p>Close the door</p> <p>Door open</p>	<p>This message appears if the door is open for too long.</p>	<p>Close the door.</p> <p>Press briefly</p> <p>Alarm is stopped.</p> <p>Note</p> <p>You can set how long it takes for this message to appear (see 5.3.24 Door alarm) .</p>
 <p>Temperature alarm</p> <p>Temperature alarm</p>	<p>This message appears if the temperature does not match the set temperature. Reasons for differences in temperature can be:</p> <p>Warm produce for cooling has been placed inside.</p> <p>Too much warm room air flowed in when rearranging and removing food.</p> <p>The power was cut off for a prolonged period.</p>	<p>Press briefly</p> <p>Information about errors and appliance status are displayed.</p> <p>Press briefly</p> <p>Warmest/coldest temperature, date and time are displayed.</p> <p>Press briefly</p> <p>The status screen is displayed.</p> <p>The current temperature and the alarm symbol flash red until the set temperature is reached.</p> <p>Check the quality of the refrigerated goods.</p>

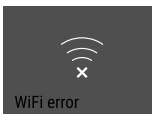
Controls

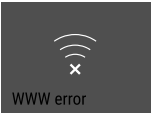
Message (red)	Cause	Remedy
 <p>Device failure</p> <p>Error</p>	<p>The appliance is faulty, there is an appliance error or a component of the appliance has a fault.</p>	<p>Store the cooled produce elsewhere.</p> <p>Press briefly</p> <p>The error code (e.g. BT021) is displayed.</p> <p>Press briefly</p> <p>A further error code is displayed if there is one</p> <p>or</p> <p>Status screen is displayed with flashing error symbol.</p> <p>Swiping or tapping the display will show the error code(s) again.</p> <p>Make a note of the error code(s) and contact customer service. (see 8.3 Customer Service)</p>  
	<p>The message indicates that freeze protection mode is active (e.g. due to frequent door openings or loading with goods).</p>	<p>Press briefly</p> <p>FRZ.PROT is displayed.</p> <p>Press briefly</p> <p>Status screen is displayed with flashing error symbol.</p> <p>Swiping or tapping the display will show the message again.</p> <p>After a few hours, the appliance automatically switches to the normal operating mode and the message disappears. Alternatively, prolonged pressing will exit the mode and close the message. Contact customer service if the message is displayed again. (see 8.3 Customer Service)</p>  
 <p>Power failure</p> <p>Power cut</p>	<p>The message appears following an interruption to the electricity supply.</p>	<p>Press briefly</p> <p>Battery's state of charge, information about errors and appliance status are displayed</p> <p>Press briefly</p> <p>Highest temperature, time period and number of electricity supply interruptions are displayed.</p> <p>Press briefly</p> <p>The status screen is displayed.</p> <p>The current temperature and the alarm symbol flash red until the set temperature is reached.</p> <p>Check the quality of the refrigerated goods.</p>
 <p>Defrost error</p> <p>Defrost error</p>	<p>The automatic defrosting is not working properly. The previous five defrost cycles were not successful.</p>	<p>Press briefly.</p> <p>Alarm is stopped.</p> <p>Contact customer service (see 8.3 Customer Service).</p>
 <p>WiFi error</p> <p>WiFi error</p>	<p>Wi-Fi connection is interrupted.</p>	<p>Check connection.</p> <p>Press briefly.</p> <p>Alarm is stopped.</p>

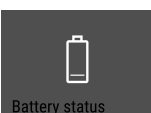
Message (red)	Cause	Remedy
 <p>WWW error, WiFi</p>	This message appears if there is no internet connection via WiFi.	Check connection. Press briefly. Alarm is stopped.
 <p>LAN error</p>	LAN connection is interrupted.	Check connection and network cable. Press briefly. Alarm is stopped.
 <p>WWW error, LAN</p>	This message appears if there is no internet connection via LAN.	Check connection. Press briefly. Alarm is stopped.
 <p>Battery error</p>	Battery voltage too low.	Replace battery (see 7.4 Replacing appliance battery) . Press briefly. Alarm is stopped.

5.4.2 Reminders

Reminders appear when you are being asked to do something. They are issued by means of an acoustic signal and visually via a symbol on the display. Acknowledge the message by pressing the confirmation button.

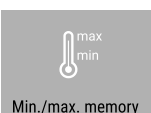
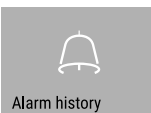
Message (yellow)	Cause	Remedy
 <p>Maintenance reminder</p>	The message appears when the timer for the set maintenance interval has expired.	Press briefly. Reminder is closed. Note The maintenance interval can be set (see 5.3.8 Maintenance interval reminder) .
 <p>Recording reminder</p>	This message appears when the temperature recording memory (999 hours) is full.	Press briefly. Reminder is closed. The oldest data is overwritten. Note The temperature recording can be reset (see 5.3.4 Temperature recording) .
 <p>Alarm log</p>	The message appears if there are more than 10 unconfirmed alarm messages.	Press briefly. Check messages. Reminder is closed.

6 Features

6.1 Safety lock

The lock in the appliance door is equipped with a safety mechanism.

6.1.1 Locking appliance

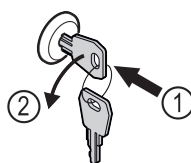

Fig. 144

- ▶ Insert key.
- ▶ Turn key anticlockwise by 90°.
- ▷ The appliance is locked.

Features

6.1.2 Unlocking appliance

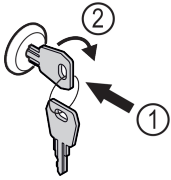

Fig. 145

- ▶ Insert key Fig. 145 (1).
- ▶ Turn key clockwise by 90° Fig. 145 (2).
- ▷ The appliance is unlocked.

6.2 Sensors

The appliance can be equipped with the following sensors for temperature monitoring:

- Safety thermostat sensor
- C sensor
- P sensor

6.2.1 Safety thermostat sensor

The safety thermostat sensor monitors the temperature drop and thus protects against excessively low temperatures (Freeze Protect). If the temperature drops below the threshold value, the appliance regulates the temperature automatically. The error message FRZ. PROT (Freeze Protect) (see 5.4 Message) appears.

6.2.2 C sensor (control sensor)

The C sensor is permanently installed and regulates the interior temperature of the appliance. You can calibrate the C sensor if necessary. (see 5.3.22 Sensor calibration)

6.2.3 P sensor (reference sensor)

The P sensor is permanently installed in the interior, in order to record and monitor the temperature in this location specifically. If the set temperature is exceeded in this location, the sensor triggers an alarm. You can calibrate the P sensor if necessary. (see 5.3.22 Sensor calibration)

6.3 Sensor info



This function makes it possible to choose between C sensor or P sensor.

Make sure that the following requirement is met:

- P sensor is connected to the appliance. (see 6.4 Interfaces)

6.3.1 Selecting C sensor

- ▶ Call up customer menu.
- ▶ Swipe left or right until corresponding function is displayed.

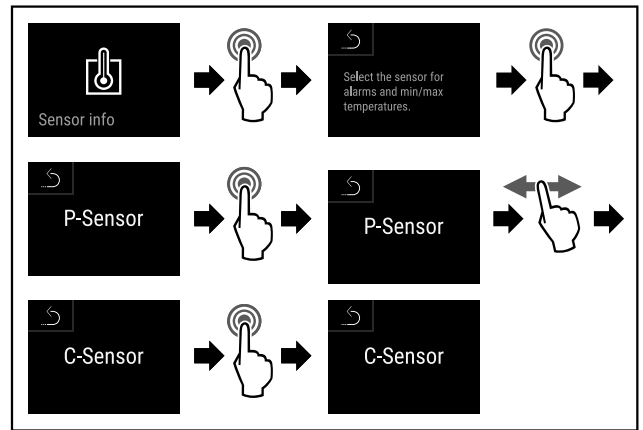

Fig. 146

- ▶ Complete steps (see Fig. 5552) .
- ▷ C sensor has been selected.

6.3.2 Selecting P sensor

- ▶ Call up customer menu.
- ▶ Swipe left or right until corresponding function is displayed.

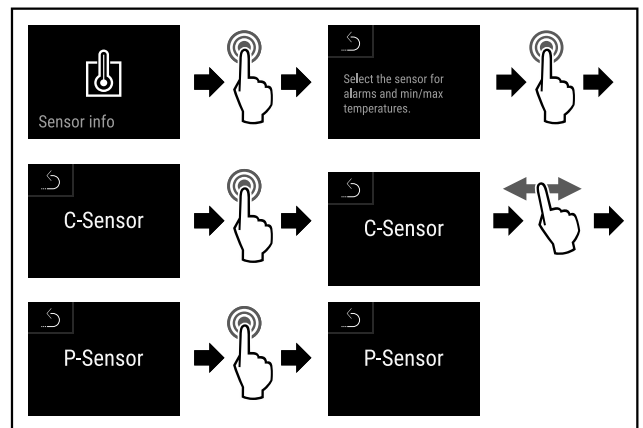

Fig. 147

- ▶ Complete steps (see Fig. 5553) .
- ▷ P sensor has been selected.

6.4 Interfaces

There are various connection options on the back of the appliance.

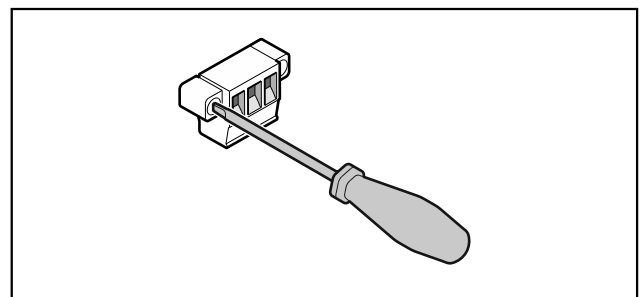

Fig. 148

Note

Screws secure the plugs. To enable disconnection of the plugs, loosen the screws on the left and right.

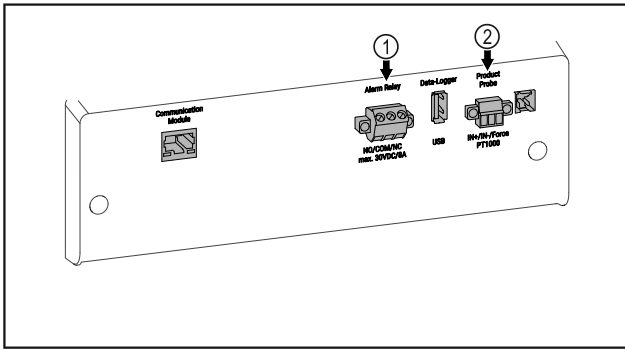

Fig. 149

- (1) Potential-free alarm output (2) Connection for P sensor output

6.4.1 Potential-free alarm output



WARNING

Risk of injury due to electric shock!

- The appliance may only be connected to an external alarm device by trained specialist personnel.

These three contacts can be used to connect a visual or an acoustic alarm device. The connection is designed for a maximum of **30 V (DC) - 8 A** from a safety low voltage source SELV (**minimum current 150 mA**).

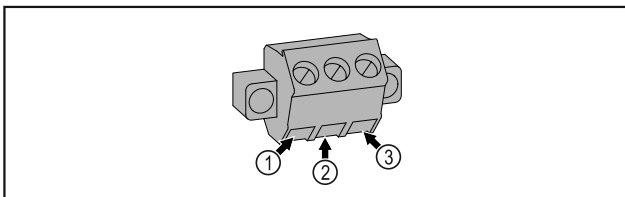

Fig. 150

- (1) NO (normally open) Connection of an alarm indicator lamp or an acoustic alarm signaling device.
- (2) COM (common) External voltage source
- (3) NC (normally closed) Connection of an indicator lamp that displays the appliance's normal mode.

6.4.2 Connection for P sensor

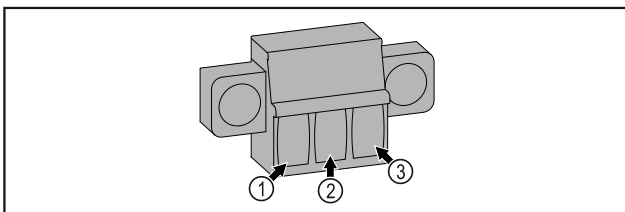

Fig. 151

- (1) IN+ (measuring line +) (3) FORCE (supply +)
(2) IN- (common return line -)

7 Maintenance

7.1 Maintenance schedule

Maintenance work is to be performed at regular intervals to ensure proper appliance function.



CAUTION

Danger of injury and damage due to unprofessional maintenance work!

Personal injury and material damage.

- Maintenance work may only be performed by trained specialist personnel.



WARNING

Short-circuit hazard due to live parts!

Electric shock or damage to the electronics.

- **Switch off the appliance.**
- Pull out mains plug or switch off fuse.

Note

A maintenance reminder function can be activated. (see 5.3.8 Maintenance interval reminder)

Note

We recommend creating a maintenance log in which all work (repairs, checks) performed is documented.

Note

Liebherr recommends yearly maintenance. For an individual offer, please contact Customer Service (see 8.3 Customer Service) .

Component	Activity	Maintenance interval
Sheet metal parts	Check for damage and corrosion. Replacement of damaged parts: (see 8.3 Customer Service)	Yearly
Door, hinges	Check alignment (see 3.14 Aligning the door) , ease of movement, and tight fit.	Yearly
Lock, door handle	Check for ease of movement and tight fit.	Yearly
Door seal	Check for damage, wear, and tight fit. A replacement door seal is available from customer service (see 7.4 Replacing appliance battery) .	Yearly

Maintenance

Component	Activity	Maintenance interval
Sensor	Calibrate sensor. (see 5.3.22 Sensor calibration)	Yearly
Sensor feedthrough	Check that the sealing compound is intact.	Yearly
Battery	Replace appliance battery. A replacement battery is available from customer service. (see 7.4 Replacing appliance battery)	5 to 10 years
Surfaces	Cleaning (see 7.3 Cleaning the appliance)	Recommendation: monthly or as required/specified at installation location
Surfaces	Disinfection	Recommendation: monthly or as required/specified at installation location
Installation location, appliance	Decontamination The appliance is suitable for room decontamination with hydrogen peroxide H ₂ O ₂ . In this context, the values of the following application specifications must not be exceeded: Concentration: maximum 250 ppm. Humidity: maximum 85%. Maximum permissible room temperature as per climate class. (see 1.4 Range of use of appliance)	Recommendation: as required/specified at installation location, maximum 2x per year
Fan air slots	Cleaning (see 7.3.3 Cleaning fan cover)	Yearly
Alarm relay Sensor	Check plug connections for tight fit.	Yearly
Mains cable	Check for damage.	Yearly or if there is a change of location
Tilt angle	Check for proper function and tight fit.	Yearly or if there is a change of location
Adjusting feet/castors	Check for proper function, damage, and tight fit. Replace damaged parts. (see 8.3 Customer Service)	Yearly

7.2 Defrosting appliance



WARNING

Improper defrosting of the appliance!
Injuries and damage.

- ▶ Do not use mechanical equipment or other methods to speed up the defrosting process other than those recommended by the manufacturer.
- ▶ Do not use electrical heating or steam-cleaning appliances, naked flames or defroster sprays to defrost.
- ▶ Do not use sharp objects to remove ice.

Defrosting is performed automatically. The defrost water drains through the opening and evaporates.

If the temperature is set very cold and/or the humidity is very high, the rear wall in the interior may ice up.

Manual defrosting:

- ▶ Switch off appliance. (see 5.3.2 Switching appliance on and off)
- ▶ Pull out mains plug.
- ▶ Store refrigerated items elsewhere.
- ▶ Leave appliance door open during defrosting process.
- ▶ Soak up remaining defrost water with a cloth, clean drain opening and the appliance.

7.3 Cleaning the appliance

7.3.1 Preparing



WARNING

Short-circuit hazard due to live parts!
Electric shock or damage to the electronics.

- ▶ **Switch off the appliance.**
- ▶ Pull out mains plug or switch off fuse.



WARNING

Risk of fire

- ▶ Do not damage the refrigeration circuit.

- ▶ Empty the appliance.
- ▶ Pull out the mains plug.

7.3.2 Cleaning housing

NOTICE

Improper cleaning!

Damage to the appliance.

- ▶ Only use soft cleaning cloths and ph-neutral all-purpose cleaners.
- ▶ Do not use abrasive sponges or steel wool which may cause scratches.
- ▶ Do not use any sharp or abrasive cleaning agents, nor any that contain sand, chloride or acid.



WARNING

Risk of injury and damage as a result of hot steam!

Hot steam can lead to burns and can damage the surfaces.

- ▶ Do not use any steam cleaners!

NOTICE

Risk of damage due to short circuit.

- ▶ When cleaning the appliance, make sure no water gets into the electrical components.
- ▶ Wipe the housing down with soft, clean cloth. If very dirty, use lukewarm water with a neutral cleaner. Glass surfaces can also be cleaned with glass cleaner.
- ▶ Clean condenser coil each year. If the condenser coil is not cleaned, this significantly reduces the efficiency of the appliance.

7.3.3 Cleaning fan cover

NOTICE

Risk of damage due to short circuit.

- ▶ When cleaning the appliance, make sure no water gets into the electrical components.

NOTICE

Improper cleaning!

Damage to the appliance.

- ▶ Only use soft cleaning cloths and ph-neutral all-purpose cleaners.
- ▶ Do not use abrasive sponges or steel wool which may cause scratches.
- ▶ Do not use any sharp or abrasive cleaning agents, nor any that contain sand, chloride or acid.

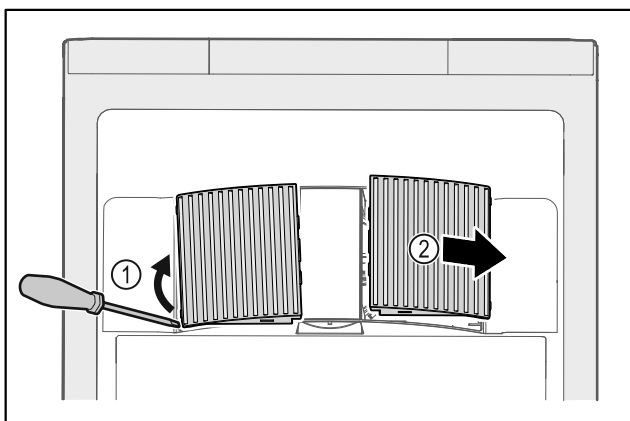

Fig. 152

- ▶ Carefully lever out fan covers from the side Fig. 152 (1) and remove towards the front Fig. 152 (2).
- ▶ Rinse the air slots of the fan covers under running water. If very dirty, use lukewarm water with a neutral cleaner.
- ▶ Leave fan covers to air-dry completely.
- ▶ Reattach fan covers to the appliance.

7.3.4 Cleaning interior



WARNING

Short-circuit hazard due to live parts!

Electric shock or damage to the electronics.

- ▶ **Switch off the appliance.**
- ▶ Pull out mains plug or switch off fuse.



WARNING

Risk of injury and damage as a result of hot steam!

Hot steam can lead to burns and can damage the surfaces.

- ▶ Do not use any steam cleaners!

NOTICE

Improper cleaning!

Damage to the appliance.

- ▶ Only use soft cleaning cloths and ph-neutral all-purpose cleaners.
- ▶ Do not use abrasive sponges or steel wool which may cause scratches.
- ▶ Do not use any sharp or abrasive cleaning agents, nor any that contain sand, chloride or acid.

Note

- ▶ Defrost water drain (see 1.2 Overview of appliance and equipment) : Remove deposits using a thin material (for example a cotton bud).

Note

Do not damage or remove the type plate on the inside of the appliance. The type plate is important for Customer Service.

- ▶ Open the door.
- ▶ Empty the appliance.
- ▶ Clean interior and equipment parts with lukewarm water and a little detergent. Do not use any gritty or acidic cleaning agent or any chemical solvent.

7.3.5 After cleaning

- ▶ Wipe appliance and equipment parts dry.
- ▶ Connect and switch on appliance. Once the temperature is sufficiently cold:
- ▶ put in items for refrigeration goods.
- ▶ Repeat cleaning regularly.
- ▶ Clean and dust refrigerators with a heat exchanger (metal grille on the rear of the appliance) once per year.

7.4 Replacing appliance battery

In the event of a power failure, the appliance battery is used to record temperature history, alarm and service messages and to show the alarm messages on the display for approximately 12 hours. During initial commissioning, the battery may take up to 24 hours to charge and be in proper working order.

A replacement battery is available from customer service (see 8.3 Customer Service).

7.4.1 Replacing battery



WARNING

Short-circuit hazard due to live parts!

Electric shock or damage to the electronics.

- ▶ **Switch off the appliance.**
- ▶ Pull out mains plug or switch off fuse.

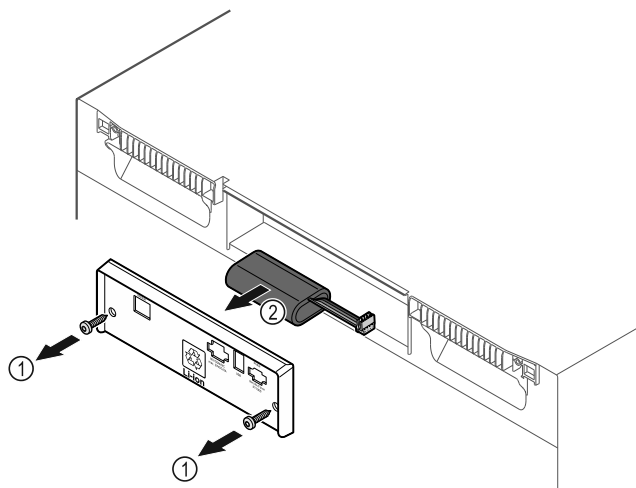

Fig. 153

- ▶ Unscrew screws and remove cover from the back of the appliance Fig. 153 (1).
- ▶ Disconnect and remove battery Fig. 153 (2).
- ▶ Install replacement battery.
- ▶ Close cover and screw in screws.
- ▶ Reconnect mains power cable.

Note

- ▶ The battery must be sent for separate waste treatment for batteries and must be disposed of in an expert and proper manner in accordance with the regulations and laws which apply locally. **Do not damage or short circuit the battery!**

8 Customer help

8.1 Technical specifications

Temperature range	
Refrigeration	+3 to +16 °C

Maximum load per shelf ^{A)}			
Appliance width (see 3.2 Appliance dimensions)	Grid shelf	Glass shelf	Wooden shelf
600 mm	45 kg	40 kg	45 kg
750 mm	60 kg	40 kg	60 kg

A) Heavier loads may result in a slight bending of the shelves.

Maximum total load and net weight		
Model (see 3.2 Appliance dimensions)	Maximum total load	Net weight
SRF.. 3501*	180 kg*	60 kg*
SRF.. 3511*	180 kg*	75 kg*
SRF.. 4001*	225 kg*	65 kg*
SRF.. 4011*	225 kg*	82 kg*
SRF.. 5501*	300 kg*	80 kg*
SRFvh 5511*	300 kg*	98 kg*

Maximum net capacity
See net capacity on the type plate (see 1.2 Overview of appliance and equipment) .

Lighting	
Energy efficiency class ^{A)}	Light source
This product contains one or more energy efficiency class F light sources	LED

A) The appliance may contain light sources with different energy efficiency classes. The lowest energy efficiency class is indicated.

WiFi frequency information	
Frequency band	2.4 GHz
Maximum radiated power	<100 mW
Purpose of the wireless equipment	Integration in the local WiFi network for data communication

Set-up conditions	
Degrees of pollution (surrounding the appliance)	PD2
Ambient temperature	+10 °C to +35 °C
Maximum relative ambient moisture	75%, not condensing
Maximum operating elevation (metres above sea level)	2000 m / 1500 m (glass door)

Electrical values	
Nominal voltage	220 - 240 V ~
Maximum mains fluctuation	+/-10%
Overvoltage categories	II

Data according to DIN 13277				
Model	Energy consumption (kWh/24h)	Temperature increase - power failure (min.)	Temperature homogeneity (°K)	Temperature consistency (°K)
4001	0.460	95	1.7	1.0
4011	0.741	65	2.7	1.7
5501	0.498	115	1.1	0.9
5511	0.794	65	1.6	1.0

8.2 Technical fault

Your appliance is designed and built to ensure it works reliably and has a long service life. In the unlikely event that a fault occurs during operation, please check whether the fault is due to an operating error. If this is the case, you will be charged for the cost incurred even if this falls within the warranty period.

You can fix the following faults yourself.

8.2.1 Appliance function

Defect	Cause	Remedy
The appliance is not working.	→ The appliance is not switched on.	▶ Switch on the appliance.
	→ The mains plug is not properly plugged into the socket.	▶ Check the mains plug.
	→ There is something wrong with the fuse in the socket.	▶ Check fuse.
	→ Power cut	▶ Keep the appliance closed. ▶ If necessary move the refrigerated/frozen items to another fridge or freezer if the power is off for a prolonged period.
	→ The appliance plug is not properly inserted in the appliance.	▶ Check appliance plug.
Temperature is not cold enough.	→ The appliance door is not closed properly.	▶ Close appliance door.
	→ Ventilation is not sufficient.	▶ Clear ventilation grille and clean it.
	→ The ambient temperature is too high.	▶ Ensure the correct ambient conditions:
	→ The appliance was opened too many times or for too long.	▶ Wait to see if the required temperature corrects itself. If not, contact Customer Service (see 8.3 Customer Service).
	→ The temperature is set incorrectly.	▶ Set a colder temperature and check after 24 hours.
	→ The appliance is too close to a heat source (oven, radiator, etc).	▶ Change where the appliance or the heat source are located.

8.3 Customer Service

First check whether you can rectify the fault yourself. If you cannot rectify the problem, contact Customer Service.

Please refer to the enclosed "Liebherr-Service" brochure for the address.



WARNING

Unprofessional repair!
Injuries.

- ▶ Have any repairs and action - not expressly specified - on the appliance and mains cable carried out by service personnel only. (see 7 Maintenance)
- ▶ A damaged mains cable may only be replaced by the manufacturer, the manufacturer's Customer Service or a similarly qualified person.
- ▶ In the case of appliances with an IEC connector, the change may be made by the customer.

8.3.1 Contacting Customer Service

Make sure you have the following appliance data at the ready:

- Appliance name (model and index)
- Service no. (Service)
- Serial no. (S no.)

▶ Access the appliance information via the display (see 5.3.17 Info).

-or-

- ▶ Refer to the type plate for appliance information. (see 8.4 Type plate)
- ▶ Note down appliance information.
- ▶ Notify Customer Service: Report errors and the appliance information.

- ▶ This will help us to provide a fast and focussed service.
- ▶ Follow any further instructions provided by Customer Services.

8.4 Type plate

The type plate is inside the appliance. See appliance overview.

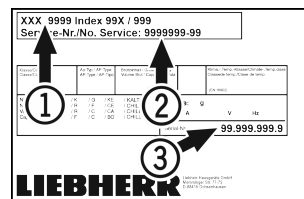

Fig. 154

- (1) Appliance designation
- (2) Service No.
- (3) Serial No.

9 Shutting down

- ▶ Empty the appliance.
- ▶ Switch off the appliance.
- ▶ Pull out the mains plug.
- ▶ Remove appliance connector if required: remove and at the same time move from left to right.
- ▶ Clean appliance (see 7.3 Cleaning the appliance).
- ▶ Leave the door open so that no bad odours form.

Note

Damage to the appliance and malfunctions!

- ▶ After shutting down, only store the appliance at the permitted room temperature of between -10 °C and +50 °C.

Disposal

10 Disposal

10.1 Preparing appliance for disposal



Liebherr uses batteries in some of its appliances. In the EU, for environmental reasons, legislation obliges the end user to remove these batteries before disposing of old appliances. If your appliance contains batteries, a corresponding notice is attached.

Lamps If you can remove the lamps yourself without destroying them, also remove these before disposal.

- ▶ Take the appliance out of operation.
- ▶ Appliances with batteries: remove the batteries. For description, see **Maintenance** chapter.
- ▶ If possible: remove lamps without destroying them.

10.2 Disposing of the appliance in an environmentally friendly manner



The appliance still contains valuable materials and must be disposed of separately from unsorted municipal waste.



Dispose of batteries separately from the old appliance. To do this, you can return the batteries free of charge to retailers as well as recycling centres and collection centres for recyclable materials.

Lamps Dispose of removed lamps via the respective collection systems.

For Germany: You can dispose of the appliance free of charge via the class 1 collection containers at the local recycling and recyclable material collection centres. When purchasing a new fridge/freezer, if the sales area > 400 m², retailers will also take back the old appliance free of charge.



WARNING

Leaking coolant and oil!

Fire. The coolant contained in the appliance is eco-friendly, but also flammable. The oil contained in the appliance is flammable. Escaping coolant and oil can ignite if the concentration is high enough and in contact with an external heat source.

- ▶ Do not damage the pipelines of the coolant circuit and the compressor.
- ▶ Transport the appliance without damaging it.
- ▶ Dispose of batteries, lamps and the appliance according to the above specifications.

11 Additional information

Further information on warranty conditions can be found in the enclosed service brochure or on the Internet at <https://home.liebherr.com>.

If there is a fault with the appliance, inform: _____

Model ID / _____

Inventory number: _____

Quick Start Guide for everyday use

Information about using this Quick Start Guide:

- This Quick Start Guide is not a substitute for the full operating instructions nor is it a substitute for appliance training.
- This Quick Start Guide provides support for everyday use and handling the appliance.
- Read the full operating instructions and the safety notes contained therein.
- This Quick Start Guide is for: SRFvh 40../55..
- Scanning the QR code will open the full operating instructions:



Intended use

This laboratory refrigerator is suitable for professional storage of products at temperatures between 3 °C and 16 °C.

Foreseeable incorrect use

Do not use the appliance for the following applications:

- Storage and refrigeration of:
 - Chemically unstable, flammable or corrosive substances
 - Blood, plasma or other body fluids for the purpose of infusion, application or introduction in the human body
- Use in potentially explosive atmospheres
- Use outdoors or in areas exposed to dampness and splashing water

When stocking, observe the following points:

- Position grid shelves according to the height required.
- Observe maximum load.
- When the storage temperature has been reached, load the appliance (compliance with cold chain).
- Keep the ventilation slots of the recirculation fan free in the interior.
- Produce for cooling must not come into contact with the evaporator on the rear wall.
- Keep liquids in closed containers.
- Leave space when storing refrigerated goods to ensure good air circulation.

Status display

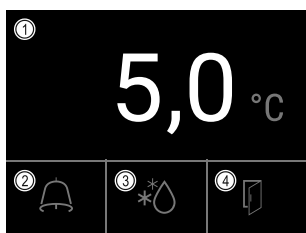

Fig. 155

(1) Actual temperature
(2) Alarm status

(3) Defrosting status
(4) Door opening status

Navigation with the touch display

Navigation	Description
	Swipe right or left Navigates within the menu.
	Press briefly Activates/deactivates function. Confirms selection. Opens submenu.
	Long press (3 seconds) Activates/deactivates function.
	Brief press of Back symbol Jumps back one level.

Displaying temperature recording

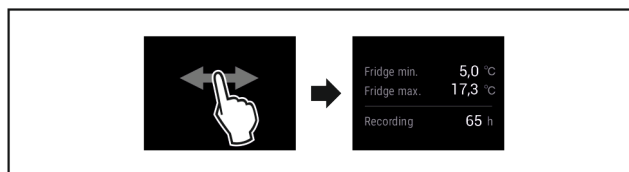

Fig. 156

► Complete steps (see Fig. 5562).

Resetting temperature recording

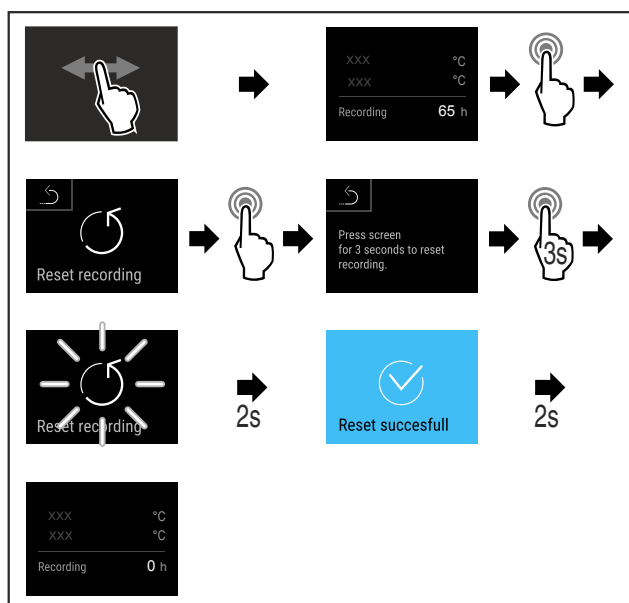

Fig. 157

► Complete steps (see Fig. 5563).

Quick Start Guide for everyday use

Unlocking appliance

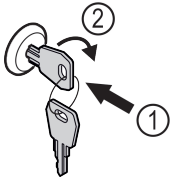

Fig. 158

- ▶ Insert the key. Fig. 158 (1)
- ▶ Turn the key clockwise by 90°. Fig. 158 (2)
- ▷ The appliance is unlocked.

Displaying alarm log

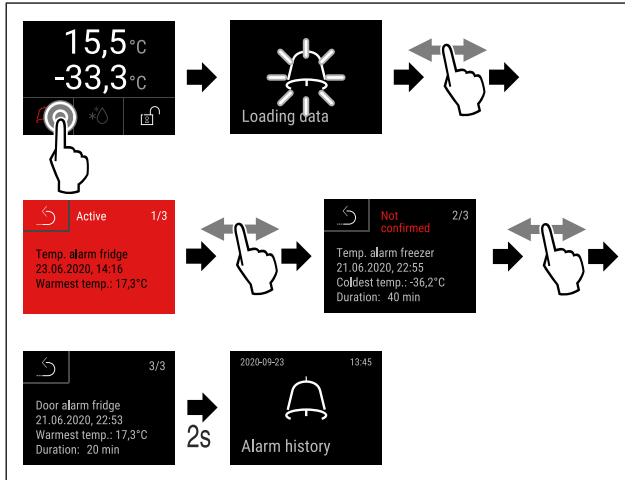

Fig. 159 Example shows an active alarm, an unconfirmed alarm, and a confirmed alarm.

- ▶ Complete steps (see Fig. 5565).
- ▷ Alarm log shows active, confirmed or unconfirmed alarms (maximum 10 alarms).
- ▷ To delete the alarm log: See operating instructions.

Cleaning appliance

- ▶ Empty the appliance.
- ▶ Pull out the mains plug.
- ▶ Observe the information in the operating instructions.
- ▶ Dry the appliance and equipment thoroughly after cleaning.
- ▶ Connect the appliance.
- ▶ Switch on the appliance.
- ▶ Load the appliance once the storage temperature is reached.



What should I do if there is a fault?

A message appears in the display if there is a fault. Messages have different meanings:

Symbol colour in the display	Meaning	Remedy
YELLOW	Reminder Reminder of general procedures. You can carry out these procedures to eliminate the message.	Consult the operating instructions and perform the troubleshooting steps.

Symbol colour in the display	Meaning	Remedy
RED	Warning Appears when there are malfunctions. You can eliminate simple malfunctions yourself.	Consult the operating instructions and perform the troubleshooting steps.
If you cannot remedy the fault yourself, contact a competent member of staff or your nearest customer service outlet.		

Cut out the page





home.liebherr.com/fridge-manuals

EN Refrigerator
ORIGINAL OPERATOR'S MANUAL

Issue date: 20230201

Part number index: 7080660-00

Liebherr Hausgeräte Lienz GmbH
Dr.-Hans-Liebherr-Strasse 1
A-9900 Lienz
Österreich

