



# CENTURIONPRO

HEMP & CANNABIS HARVESTING SOLUTIONS



**TIMKEN**  
Where You Turn



**BALDOR**  
MOTORS AND DRIVES

## XL 5.0 SE - 60HZ MODEL

## INFORMATION PACKAGE

## XL 5.0 SE TRIMMER 60HZ - TECHNICAL DATA SHEET

The XL 5.0 system is an automated cannabis and hemp trimming system capable of high throughputs of wet or dry material. The system consists of multiple components and is composed of the following: XL 5.0 Trimmer, XL 5.0 HEPA Filter Leaf Collector Bags, XL 5.0 Blowers, XL 5.0 Infeed Conveyor, and XL 5.0 QC Conveyor.

SYSTEM FEATURES	XL 5.0 SE
<b>Throughput</b>	Up to 2,250 lbs/hour Wet (450 lbs/hour Dry)
<b>Power Requirements</b>	3HP 220V 3-Phase 150Amp
<b>Tumbler/Reel Motor</b>	1HP 220V 3-Phase 3Amp
<b>Vac Motor</b>	5 x 8HP 220V 3-Phase 21Amp
<b>Infeed Conveyor Motor</b>	0.5HP 220V 3-Phase 1.6Amp
<b>Quality Control Conveyor Motor</b>	0.75HP 220V 3-Phase 3Amp
<b>Cutting System</b>	Dual-Belt Drive System 15 x 11 Blade Cutting Reels (26")
<b>Effective Cut Length</b>	390 Inch
<b>Vacuum Airflow</b>	5 x 5000 CFM
<b>Trim Separation</b>	Triple Bag Trim Collection System
<b>Lifting Mechanism</b>	Manually Actuated to 10°
<b>Food Grade</b>	Yes
<b>Washdown rating</b>	IP65
<b>RoHS compliant</b>	Yes
<b>Automation</b>	Schneider Automation
<b>Primary Material</b>	Stainless Steel and Anodized Aluminum
<b>Electrical Safety</b>	CSA

1. Both values are the input rates for bucked material. Wet material denotes fully hydrated, dry material denotes 9-13% moisture content.

Based on tested values conducted by CPro Solutions Inc.

2. Machine also available as 50Hz model

3. 220V system has CSA certification only (pending)

## **XL 5.0 SE TRIMMER 60HZ - TECHNICAL DATA SHEET**

<b>MATERIAL SPECS</b>	<b>XL 5.0 SE</b>
<b>Frame</b>	304 Stainless Steel and Anodized Aluminum
<b>Tumbler Screen</b>	304 Stainless Steel
<b>Blade Pivot Screws</b>	304 Stainless Steel
<b>Fasteners</b>	304 Stainless Steel
<b>Blades</b>	Nitrided Carbon Steel
<b>Bearings</b>	Steel
<b>Bearing Grease</b>	Food Grade Grease
<b>Fastener Grease</b>	FDA-Approved Anti-Seize
<b>Brush</b>	Food Grade Nylon
<b>Sheet metal body</b>	Powder-Coated Steel
<b>Flexible Ducting</b>	FDA-Compliant Food Grade
<b>Trim Collection</b>	Triple Bag Trim Collection System
<b>Hopper</b>	Food Grade Plastic

## XL 5.0 SE TRIMMER 60HZ - TECHNICAL DATA SHEET

<b>CUTTING REELS 1 &amp; 2 / TUMBLER MOTOR</b>		<b>SPECS</b>
<b>Make</b>	Baldor Industrial	
<b>Model</b>	VEM35XX	
<b>Material</b>	Stainless Steel Construction	
<b>HP</b>	1HP (5-Motors Total, 5HP Total)	
<b>RPM (Full Load)</b>	1,800 (1,760) RPM	
<b>Voltage</b>	220V	
<b>Phase</b>	3-Phase	
<b>Amps</b>	3A	
<b>Frequency</b>	60 Hz	
<b>Frame Size</b>	56C	
<b>Mounting</b>	Footed	
<b>Enclosure</b>	TEFC	
<b>Full Load Running Current</b>	12.4A	
<b>Locked Rotor Current</b>	1.07A	
<b>Motor Efficiency (@ 100%)</b>	85.8	
<b>Motor Efficiency (@ 75%)</b>	85.4	
<b>Motor Efficiency (@ 50%)</b>	82.9	
<b>Power Factor (@100%)</b>	69	
<b>Power Factor (@75%)</b>	60	
<b>Power Factor (@50%)</b>	46	
<b>Full Load Torque</b>	2.99 Lb.-Ft	
<b>Locked Rotor Torque (% of Full Load)</b>	8.52 Lb.-Ft	
<b>Breakdown Torque (% of Full Load)</b>	13.5 Lb.-Ft	
<b>Construction Materials</b>	Stainless Steel	
<b>Washdown</b>	Yes (IP65)	
<b>CUTTING REEL 3 MOTOR</b>		<b>SPECS</b>
<b>Make</b>	Baldor Industrial	
<b>Material</b>	Stainless Steel Construction	
<b>HP</b>	0.25HP (5-Motors Total, 1.25HP Total)	
<b>Voltage</b>	220V	
<b>Phase</b>	3-Phase	
<b>Amps</b>	1.4A	
<b>Frequency</b>	60 Hz	

**SCHEMATIC DRAWING - XL 5.0 SE TRIMMER 60 Hz with HOPPER**

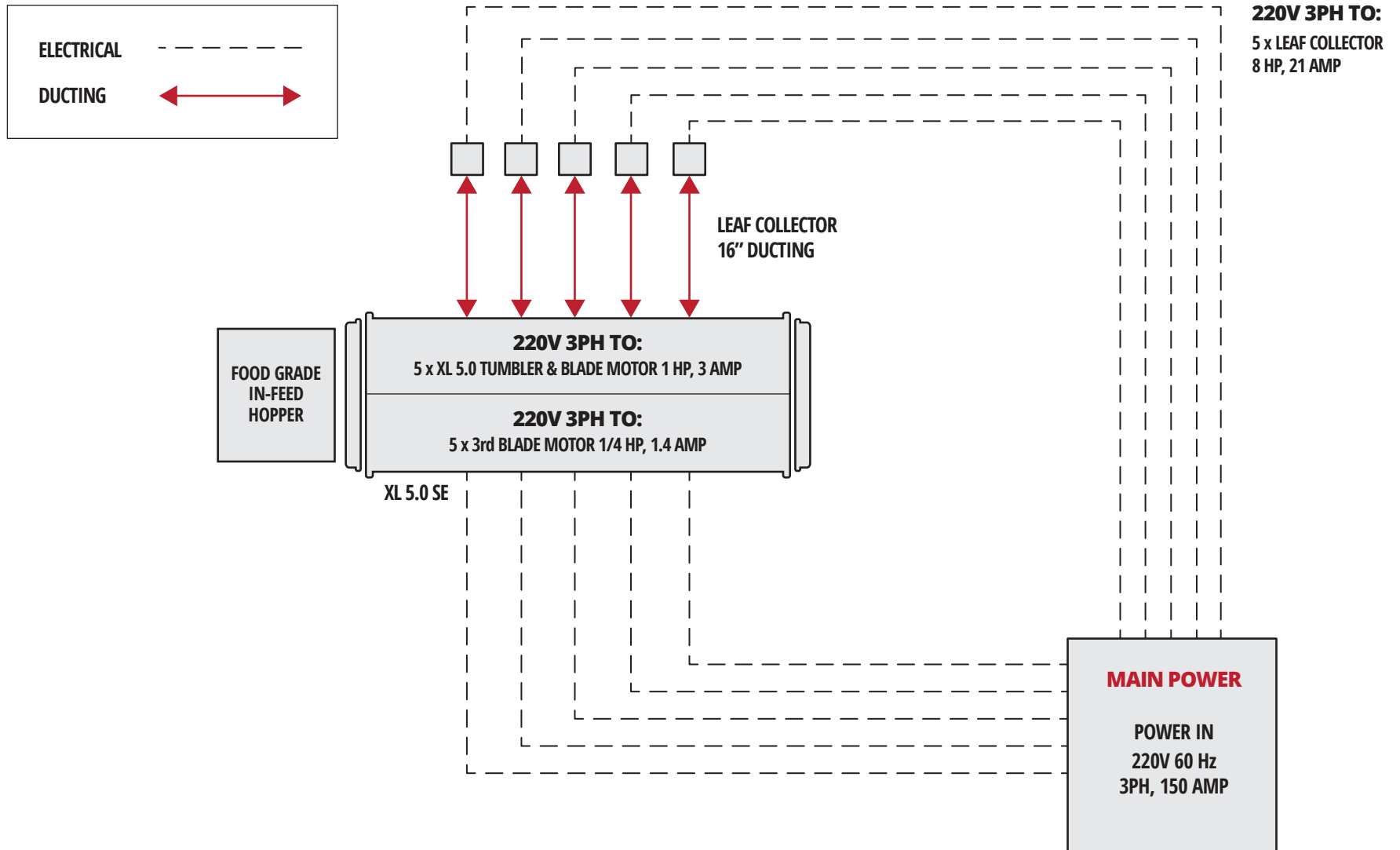

**SCHEMATIC DRAWING - XL 5.0 SE TRIMMER 60 Hz with CONVEYORS**

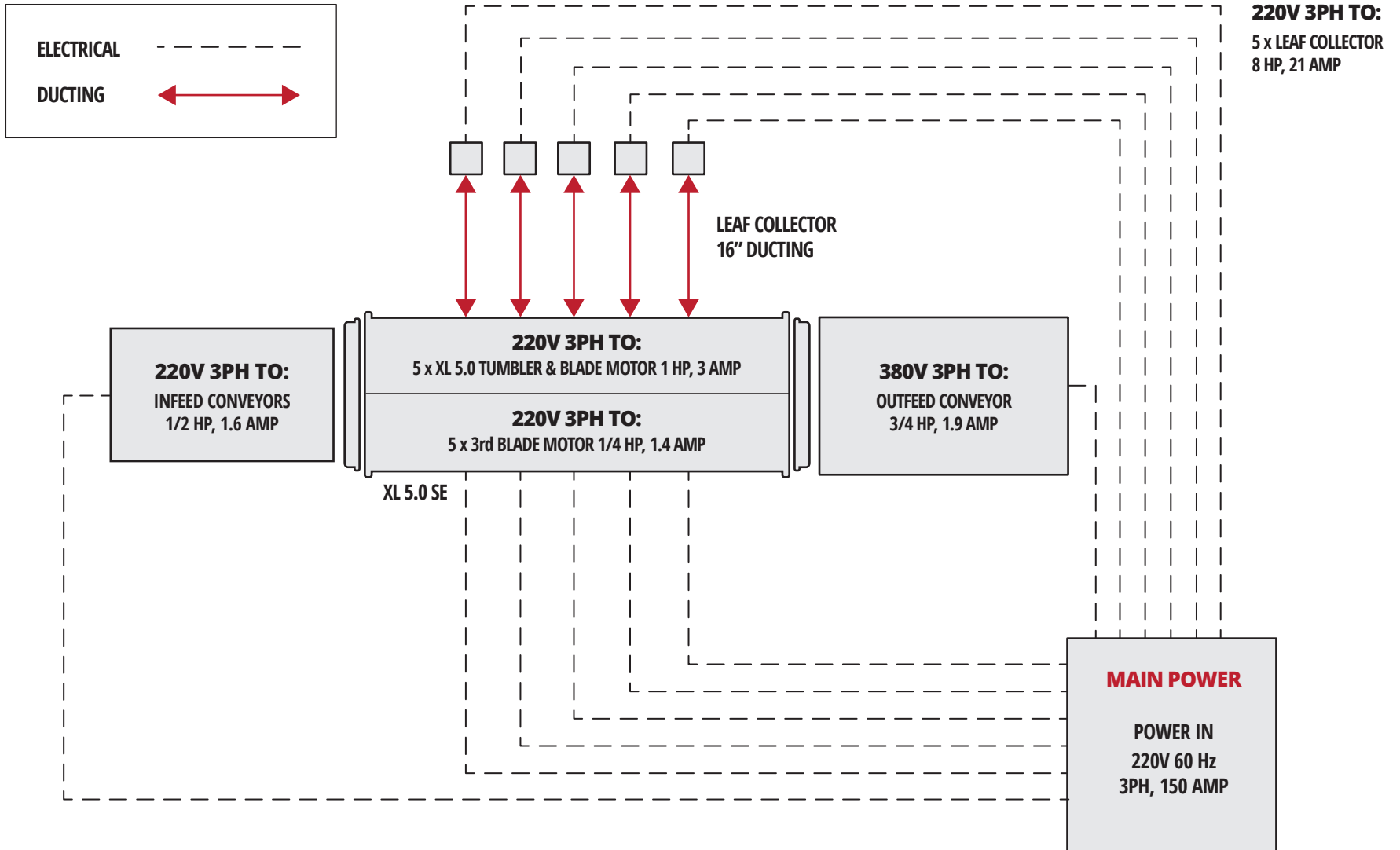

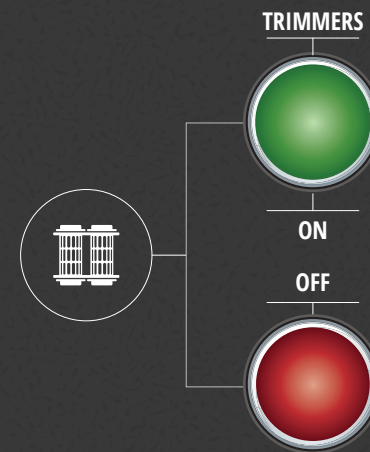
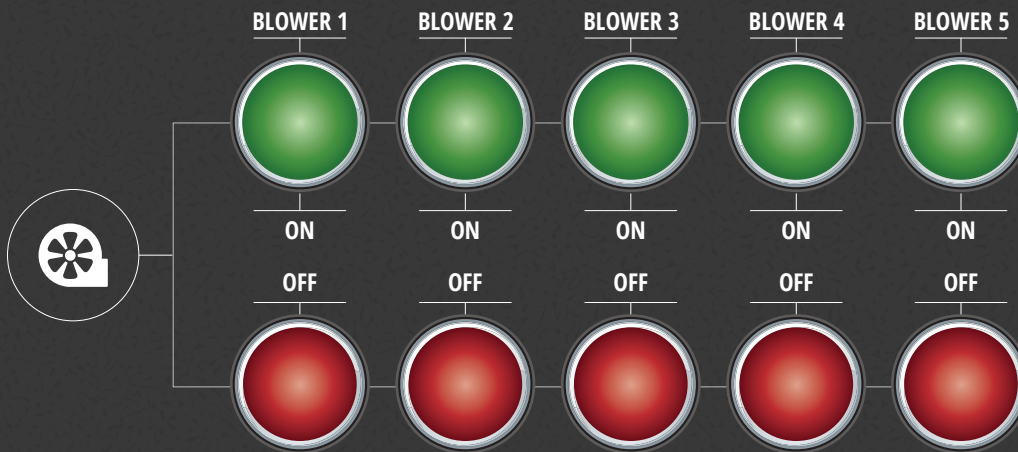
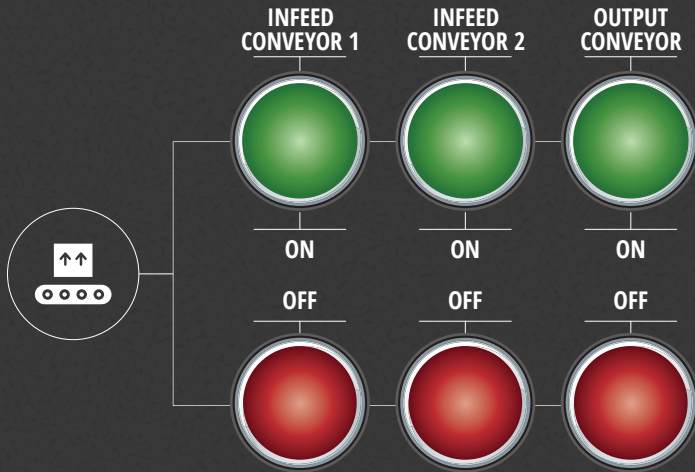

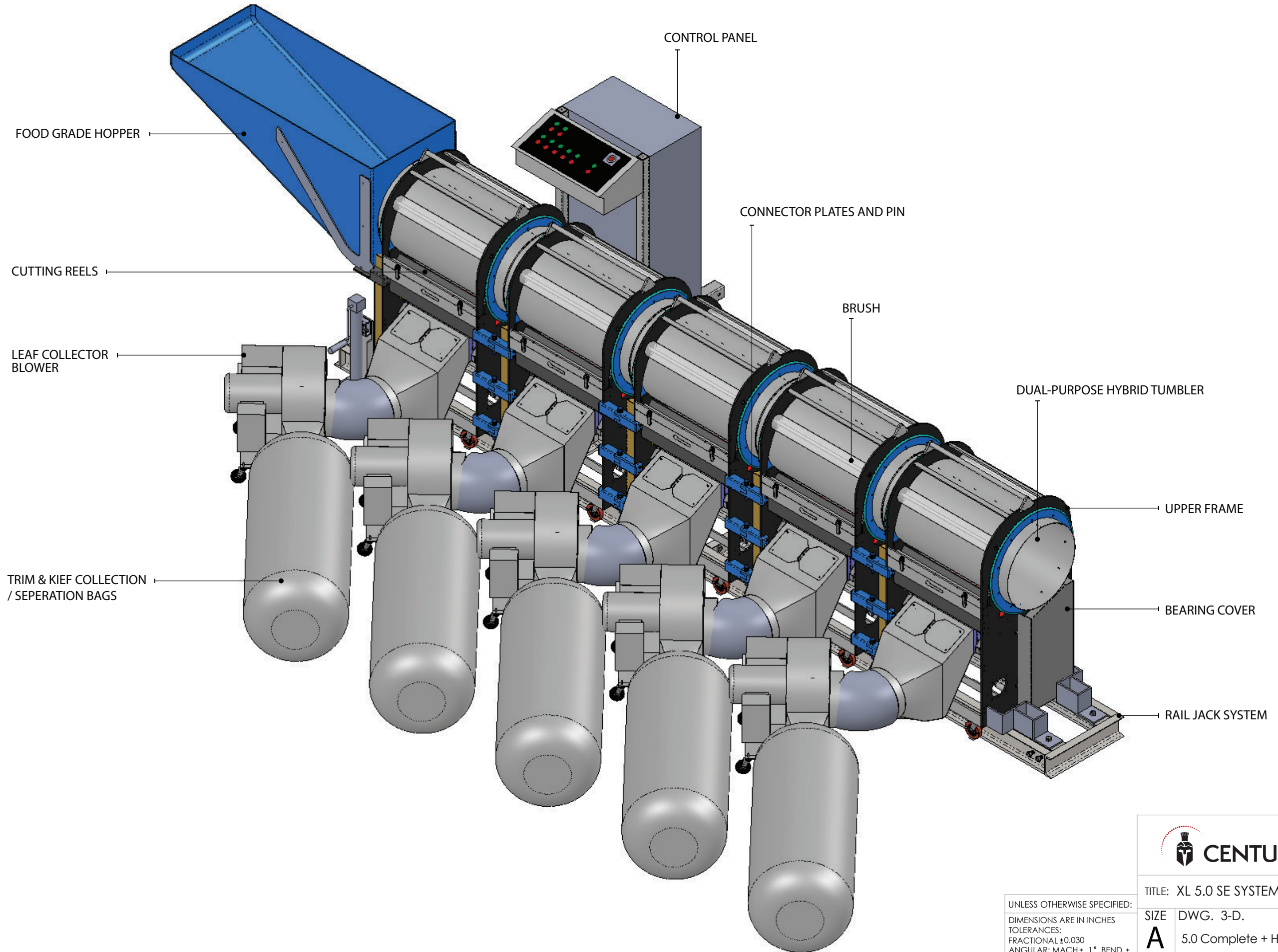

UNLESS OTHERWISE SPECIFIED:  
 DIMENSIONS ARE IN INCHES  
 TOLERANCES:  
 FRACTIONAL  $\pm 0.030$   
 ANGULAR: MACH  $\pm 1^\circ$  BEND  $\pm$   
 TWO PLACE DECIMAL  $\pm .010$   
 THREE PLACE DECIMAL  $\pm .005$



TITLE: XL 5.0 SE SYSTEM

SIZE	DWG. 3-D.	REV
<b>A</b>	5.0 Complete + Hopper	-



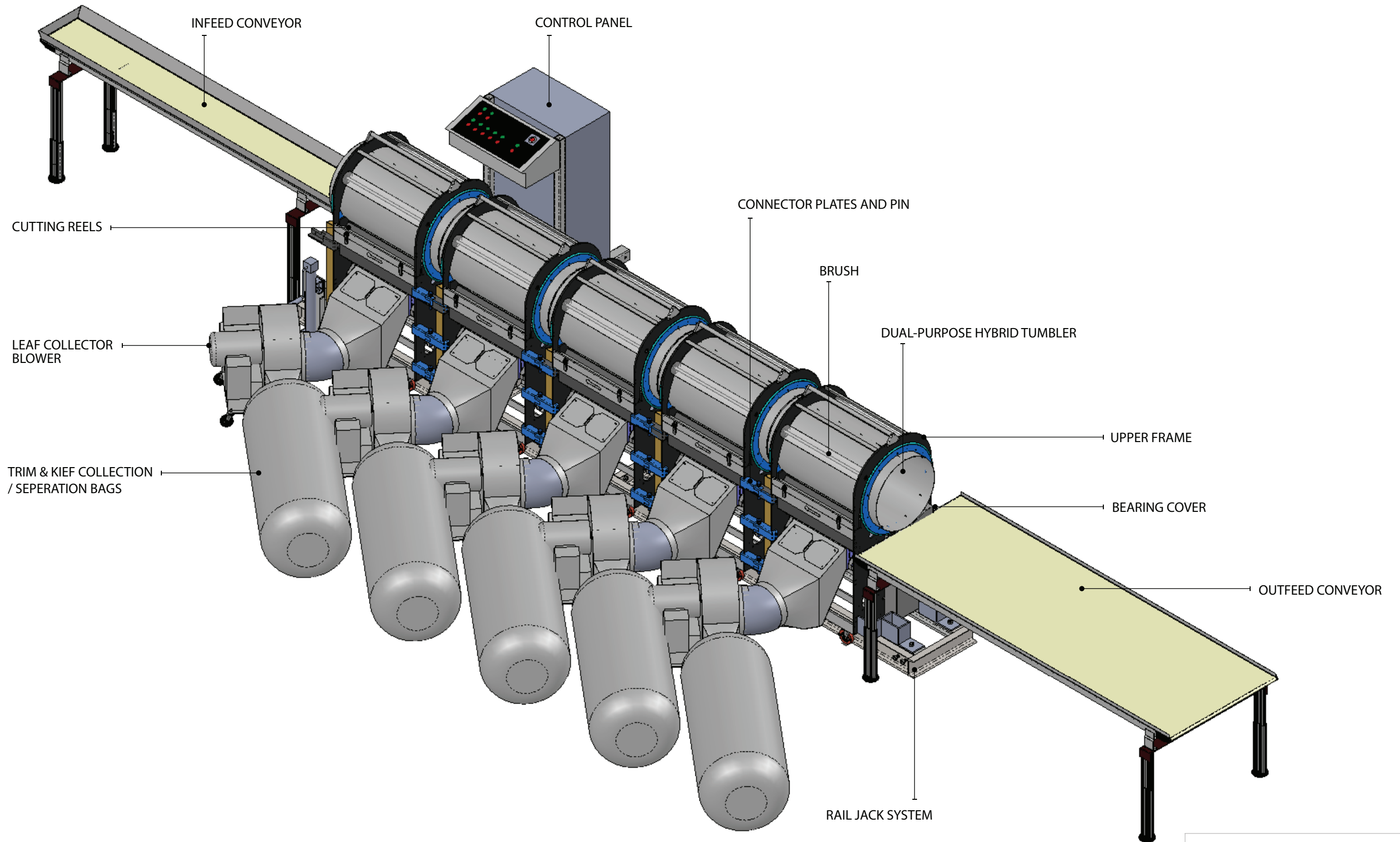

TITLE: XL 5.0 SE SYSTEM

UNLESS OTHERWISE SPECIFIED:  
 DIMENSIONS ARE IN INCHES  
 TOLERANCES:  
 FRACTIONAL  $\pm 0.030$   
 ANGULAR: MACH  $\pm 1^\circ$  BEND  $\pm$   
 TWO PLACE DECIMAL  $\pm .010$   
 THREE PLACE DECIMAL  $\pm .005$

SIZE	DWG. 3-D.	REV
A	5.0 Complete + Conveyors	-

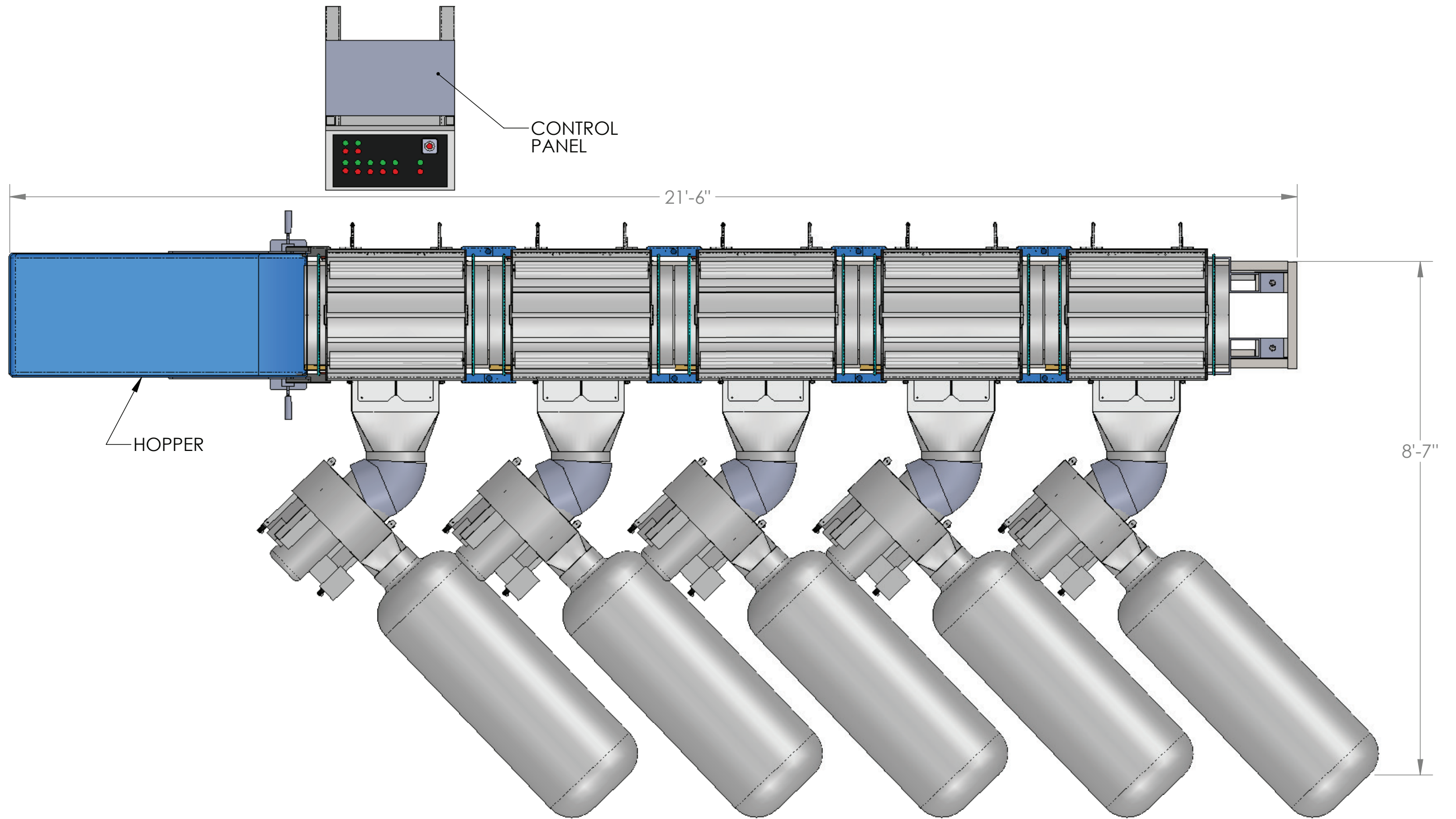

TITLE: XL 5.0 SE SYSTEM

UNLESS OTHERWISE SPECIFIED:  
 DIMENSIONS ARE IN INCHES  
 TOLERANCES:  
 FRACTIONAL ±0.030  
 ANGULAR: MACH ± 1° BEND ±  
 TWO PLACE DECIMAL ±.010  
 THREE PLACE DECIMAL ±.005

SIZE	DWG. TOP.	REV
A	5.0 Complete + Hopper	-

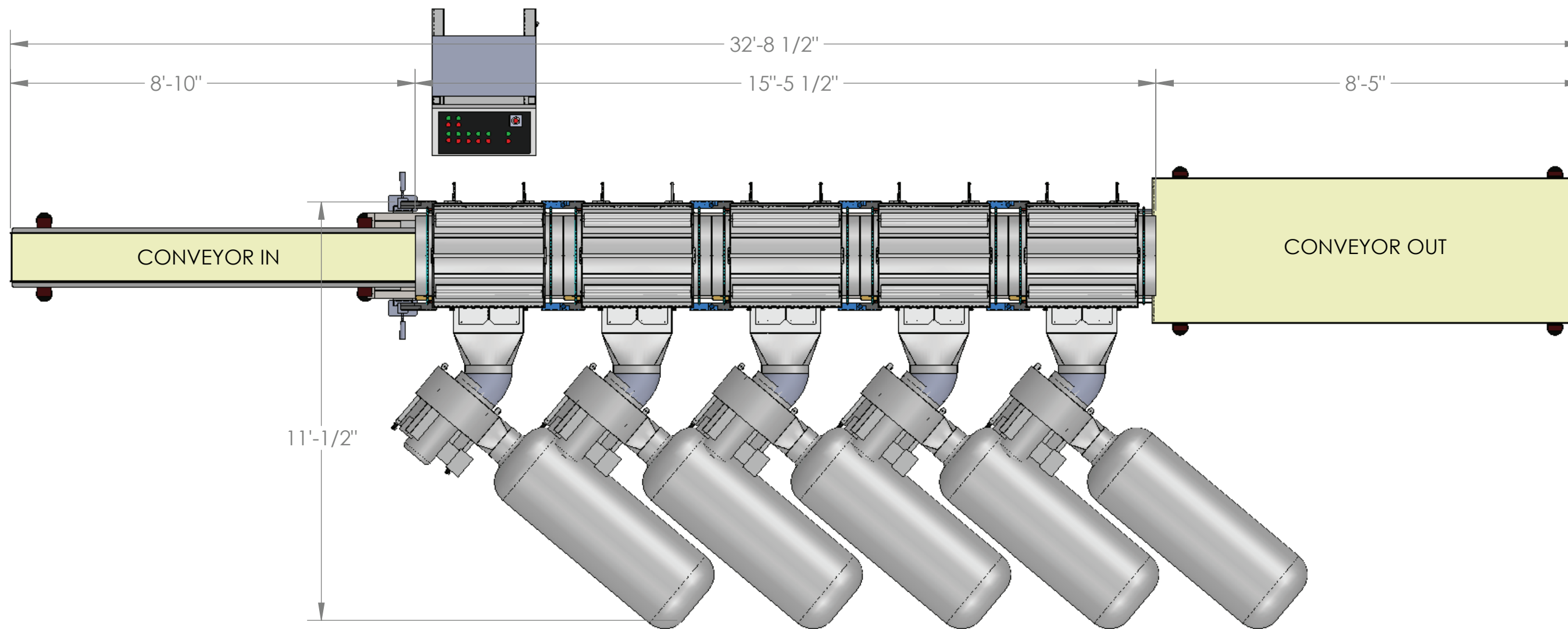

TITLE: XL 5.0 SE SYSTEM

UNLESS OTHERWISE SPECIFIED:  
 DIMENSIONS ARE IN INCHES  
 TOLERANCES:  
 FRACTIONAL ±0.030  
 ANGULAR: MACH ± 1° BEND ±  
 TWO PLACE DECIMAL ±.010  
 THREE PLACE DECIMAL ±.005

SIZE	DWG. TOP.	REV
A	5.0 Complete + Conveyors	-

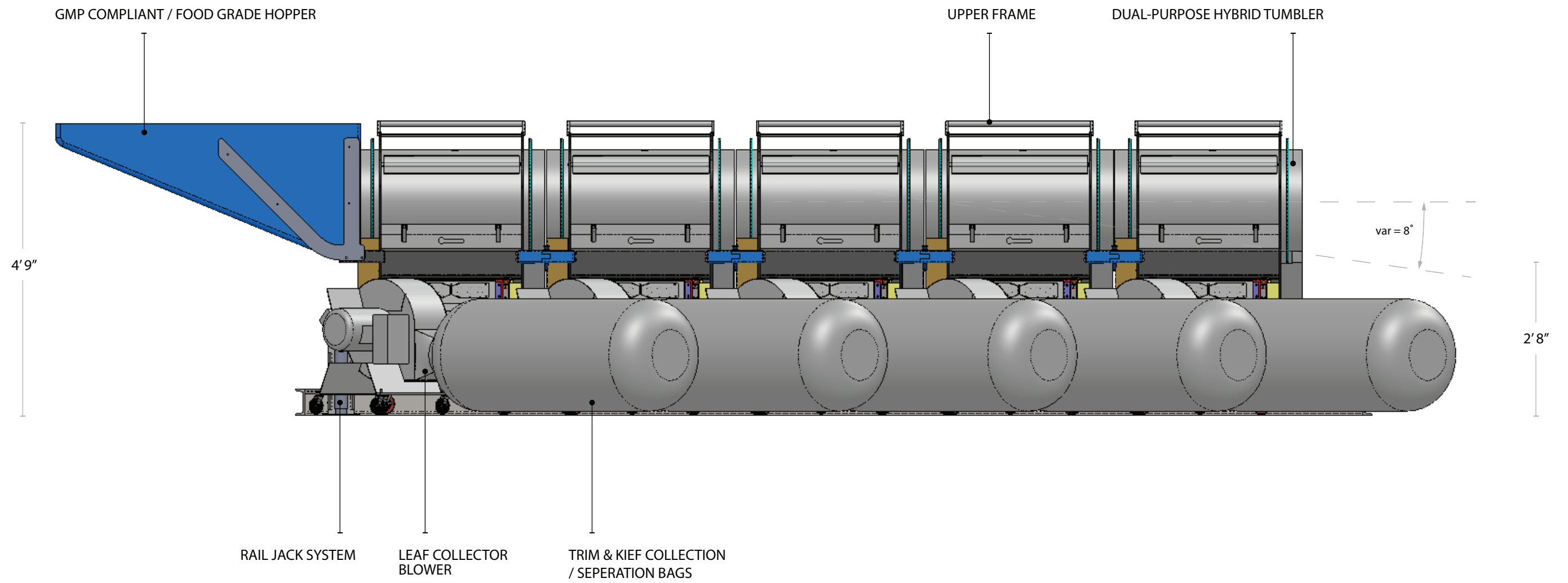

TITLE: XL 5.0 SE SYSTEM

UNLESS OTHERWISE SPECIFIED:  
 DIMENSIONS ARE IN INCHES  
 TOLERANCES:  
 FRACTIONAL ±0.030  
 ANGULAR: MACH ± 1° BEND ±  
 TWO PLACE DECIMAL ±.010  
 THREE PLACE DECIMAL ±.005

SIZE	DWG. SIDE.	REV
A	5.0 Complete + Hopper	-

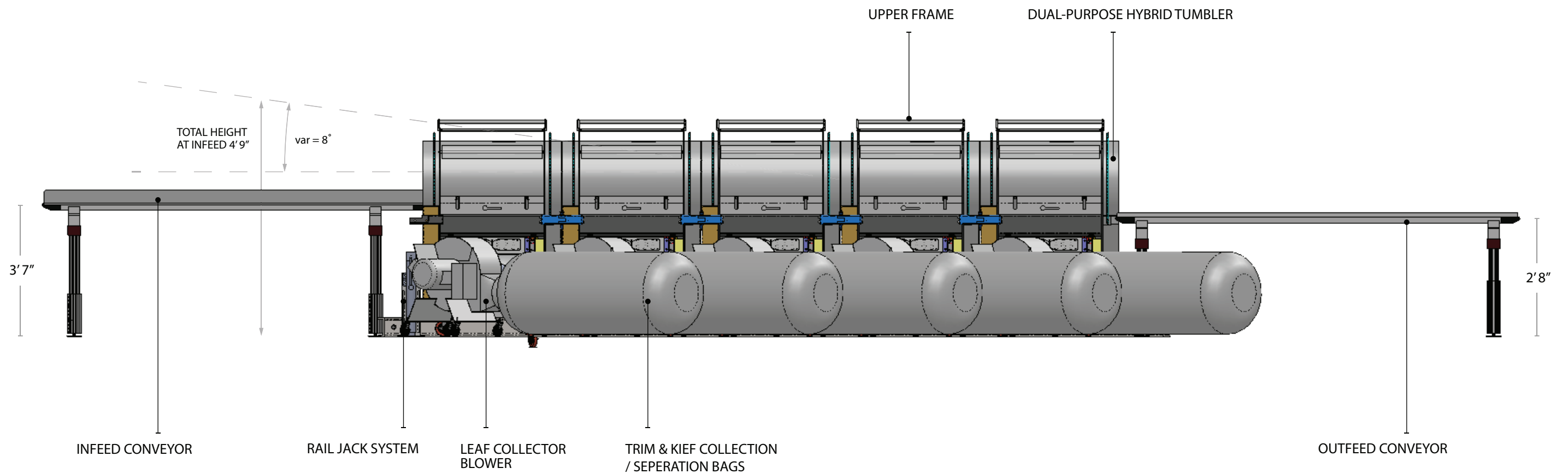

TITLE: XL 5.0 SE SYSTEM

UNLESS OTHERWISE SPECIFIED:  
 DIMENSIONS ARE IN INCHES  
 TOLERANCES:  
 FRACTIONAL ±0.030  
 ANGULAR: MACH ± 1° BEND ±  
 TWO PLACE DECIMAL ±.010  
 THREE PLACE DECIMAL ±.005

SIZE	DWG. SIDE.	REV
A	5.0 Complete + Conveyors	-