



CENTURIONPRO

HEMP & CANNABIS HARVESTING SOLUTIONS



XL 5.0 SE - 50HZ MODEL

INFORMATION PACKAGE



XL 5.0 SE TRIMMER 50HZ - TECHNICAL DATA SHEET

The XL 5.0 system is an automated cannabis and hemp trimming system capable of high throughputs of wet or dry material. The system consists of multiple components and is composed of the following: XL 5.0 Trimmer, XL 5.0 HEPA Filter Leaf Collector Bags, XL 5.0 Blowers, XL 5.0 Infeed Conveyor, and XL 5.0 QC Conveyor.

SYSTEM FEATURES	XL 5.0 SE
Throughput	Up to 2,250 lbs/hour Wet (450 lbs/hour Dry)
Power Requirements	3HP 380V 3-Phase 100Amp
Tumbler/Reel Motor	1HP 380V 3-Phase 1.6Amp
Vac Motor	5 x 8HP 380V 3-Phase 11Amp
Infeed Conveyor Motor	0.5HP 380V 3-Phase 1Amp
Quality Control Conveyor Motor	0.75HP 380V 3-Phase 1.9Amp
Cutting System	Dual-Belt Drive System 15 x 11 Blade Cutting Reels (26")
Tumbler Diameter	20 Inch
Vacuum Airflow	5 x 5000 CFM
Trim Separation	Triple Bag Trim Collection System
Lifting Mechanism	Manually Actuated to 10°
Food Grade	Yes
Washdown rating	IP65
RoHS compliant	Yes
Automation	Schneider Automation
Primary Material	Stainless Steel and Anodized Aluminum
Electrical Safety	CSA

1. Both values are the input rates for bucked material. Wet material denotes fully hydrated, dry material denotes 9-13% moisture content.

Based on tested values conducted by CPro Solutions Inc.

2. Machine also available as 60Hz model

3. 380V system has CSA certification only (pending)

XL 5.0 SE TRIMMER 50HZ - TECHNICAL DATA SHEET

MATERIAL SPECS	XL 5.0 SE
Frame	304 Stainless Steel and Anodized Aluminum
Tumbler Screen	304 Stainless Steel
Blade Pivot Screws	304 Stainless Steel
Fasteners	304 Stainless Steel
Blades	Nitrided Carbon Steel
Bearings	Steel
Bearing Grease	Food Grade Grease
Fastener Grease	FDA-Approved Anti-Seize
Brush	Food Grade Nylon
Sheet metal body	Powder-Coated Steel
Flexible Ducting	FDA-Compliant Food Grade
Trim Collection	Triple Bag Trim Collection System
Hopper	Food Grade Plastic

XL 5.0 SE TRIMMER 50HZ - TECHNICAL

CUTTING REELS 1 & 2 / TUMBLER MOTOR		SPECS
Make	Baldor Industrial	
Model	VEM35XX	
Material	Stainless Steel Construction	
HP	1HP (5-Motors Total, 5HP Total)	
RPM (Full Load)	1,800 (1,760) RPM	
Voltage	380V	
Phase	3-Phase	
Amps	1.6A	
Frequency	50 Hz	
Frame Size	56C	
Mounting	Footed	
Enclosure	TEFC	
Full Load Running Current	12.4A	
Locked Rotor Current	1.07A	
Motor Efficiency (@ 100%)	85.8	
Motor Efficiency (@ 75%)	85.4	
Motor Efficiency (@ 50%)	82.9	
Power Factor (@100%)	69	
Power Factor (@75%)	60	
Power Factor (@50%)	46	
Full Load Torque	2.99 Lb.-Ft	
Locked Rotor Torque (% of Full Load)	8.52 Lb.-Ft	
Breakdown Torque (% of Full Load)	13.5 Lb.-Ft	
Construction Materials	Stainless Steel	
Washdown	Yes (IP65)	
CUTTING REEL 3 MOTOR		SPECS
Make	Baldor Industrial	
Material	Stainless Steel Construction	
HP	0.25HP (5-Motors Total, 1.25HP Total)	
Voltage	380V	
Phase	3-Phase	
Amps	1A	
Frequency	50 Hz	

SCHEMATIC DRAWING - XL 5.0 SE TRIMMER 50 Hz with HOPPER

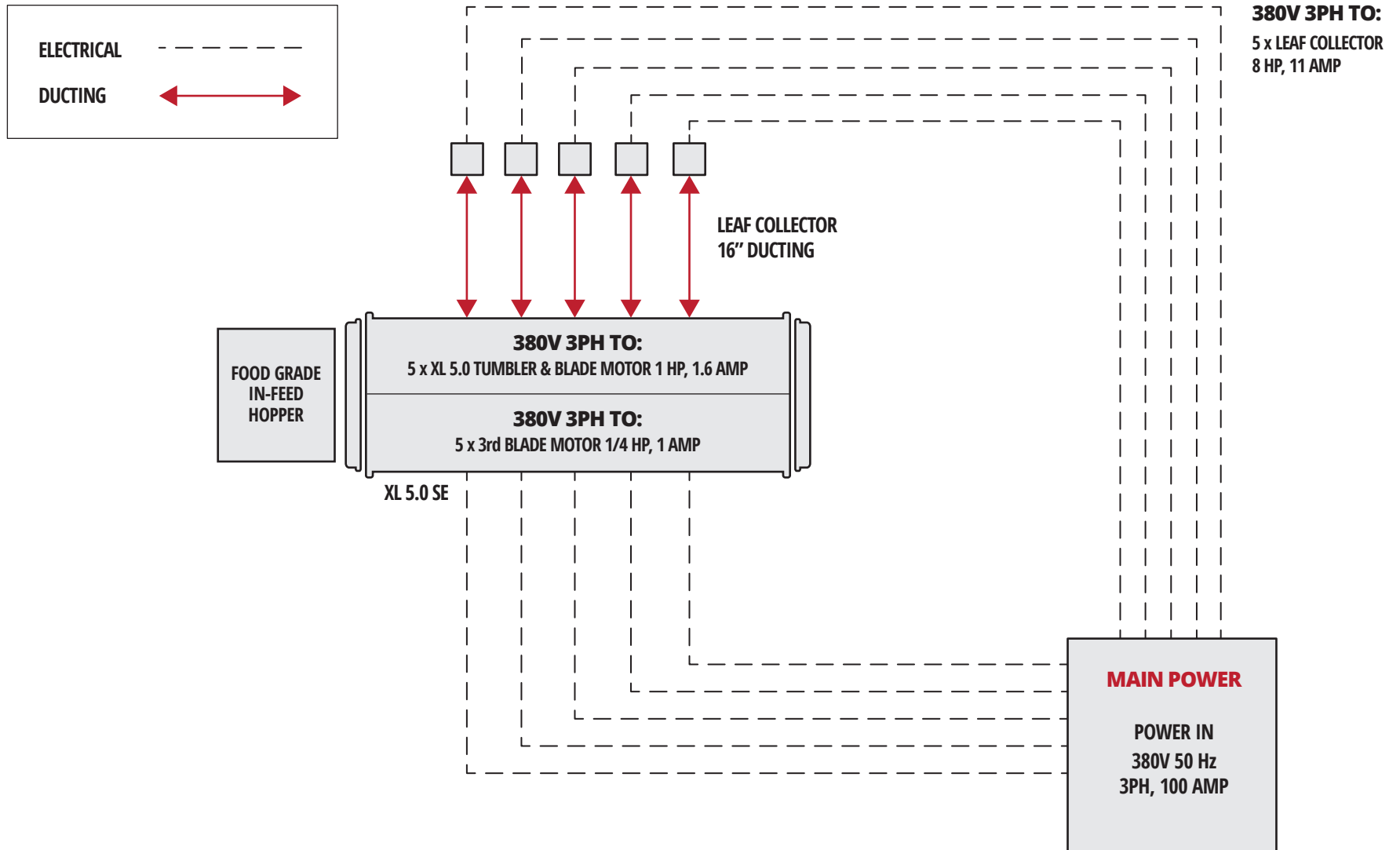

SCHEMATIC DRAWING - XL SE 5.0 TRIMMER 50 Hz with CONVEYORS

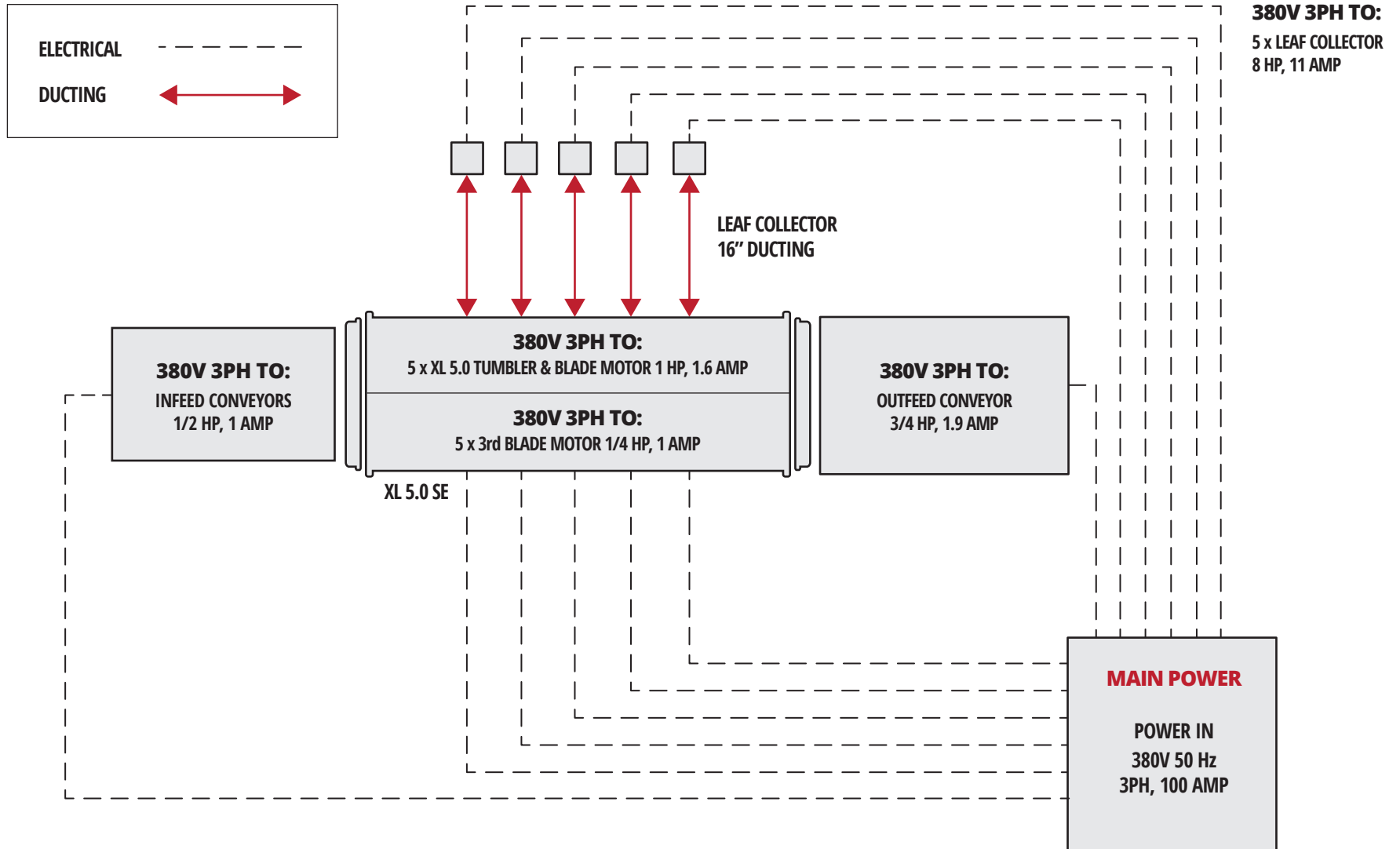

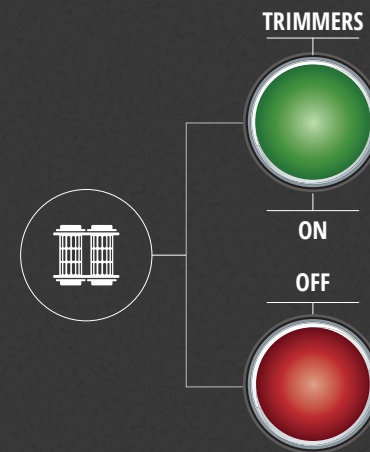
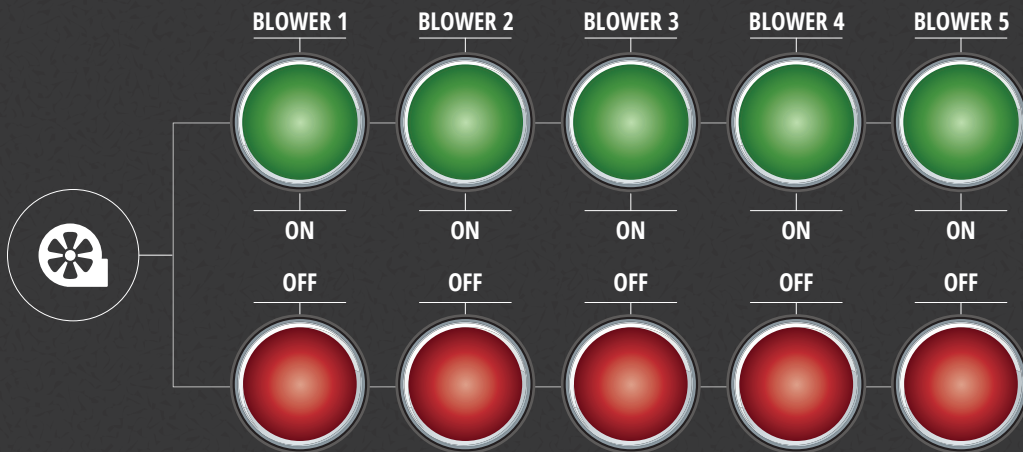
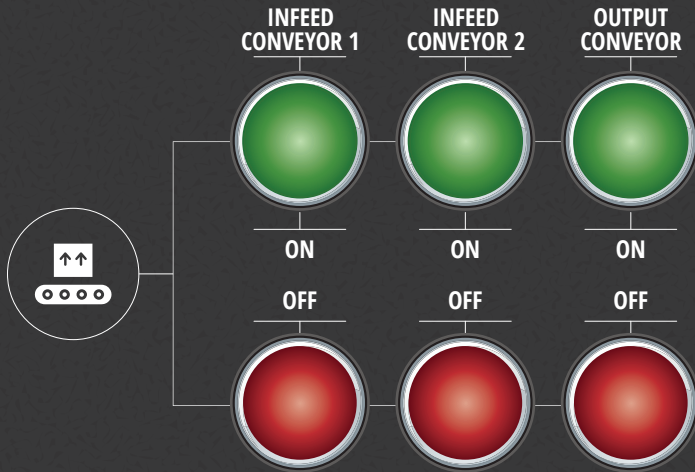

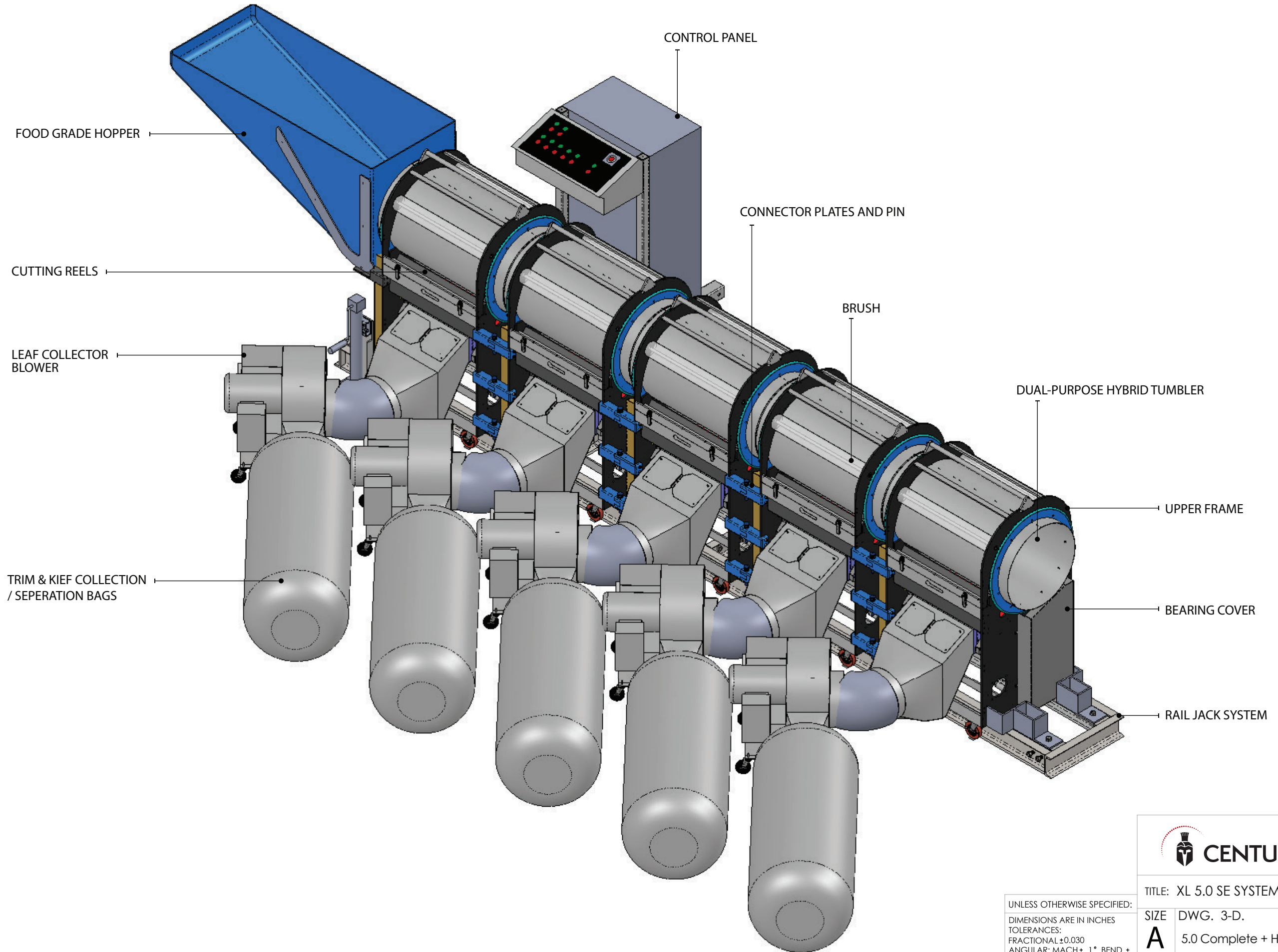

UNLESS OTHERWISE SPECIFIED:
 DIMENSIONS ARE IN INCHES
 TOLERANCES:
 FRACTIONAL ± 0.030
 ANGULAR: MACH $\pm 1^\circ$ BEND \pm
 TWO PLACE DECIMAL $\pm .010$
 THREE PLACE DECIMAL $\pm .005$



TITLE: XL 5.0 SE SYSTEM

SIZE	DWG. 3-D.	REV
A	5.0 Complete + Hopper	-

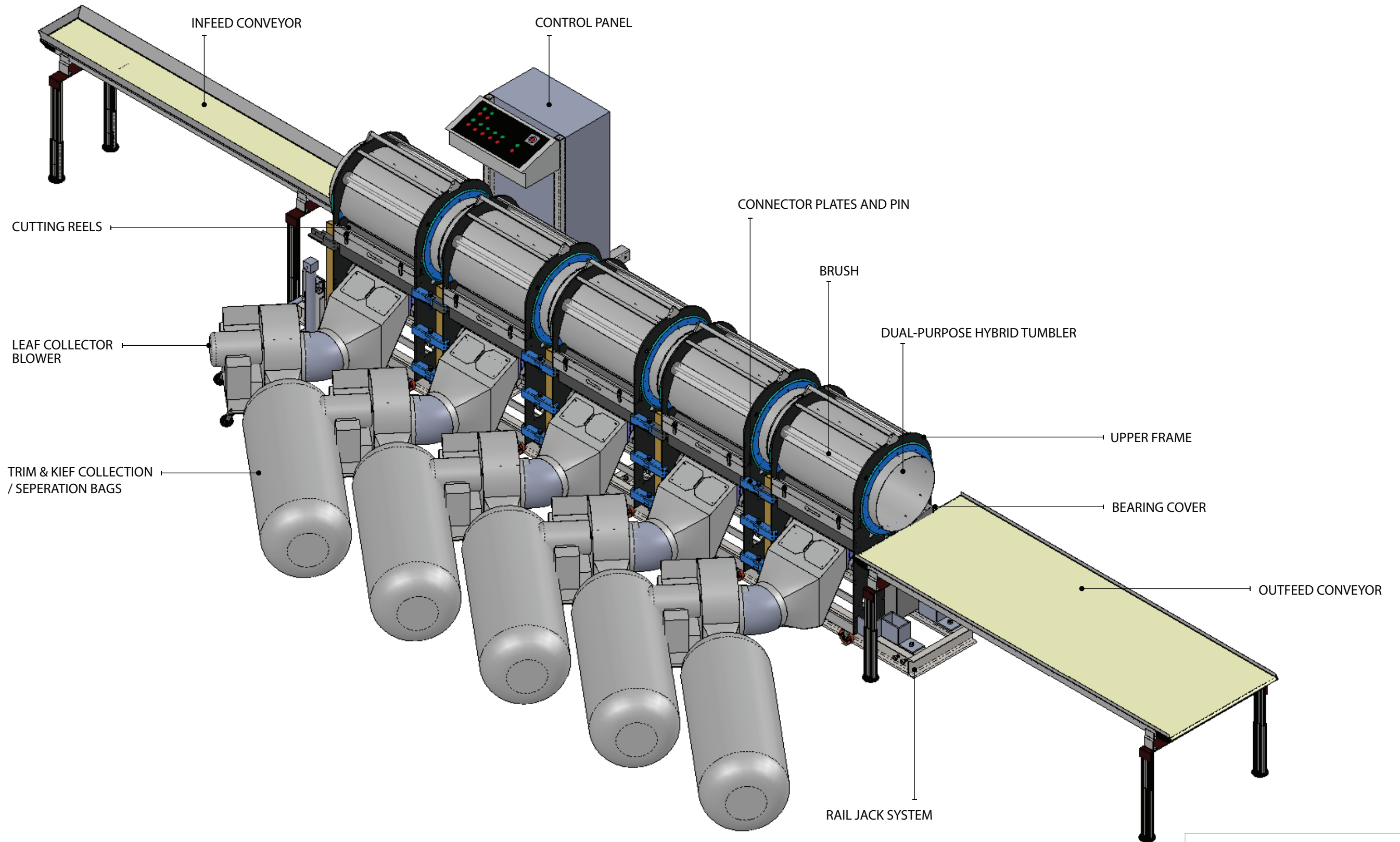

TITLE: XL 5.0 SE SYSTEM

UNLESS OTHERWISE SPECIFIED:
 DIMENSIONS ARE IN INCHES
 TOLERANCES:
 FRACTIONAL ±0.030
 ANGULAR: MACH ± 1° BEND ±
 TWO PLACE DECIMAL ±.010
 THREE PLACE DECIMAL ±.005

SIZE	DWG. 3-D.	REV
A	5.0 Complete + Conveyors	-

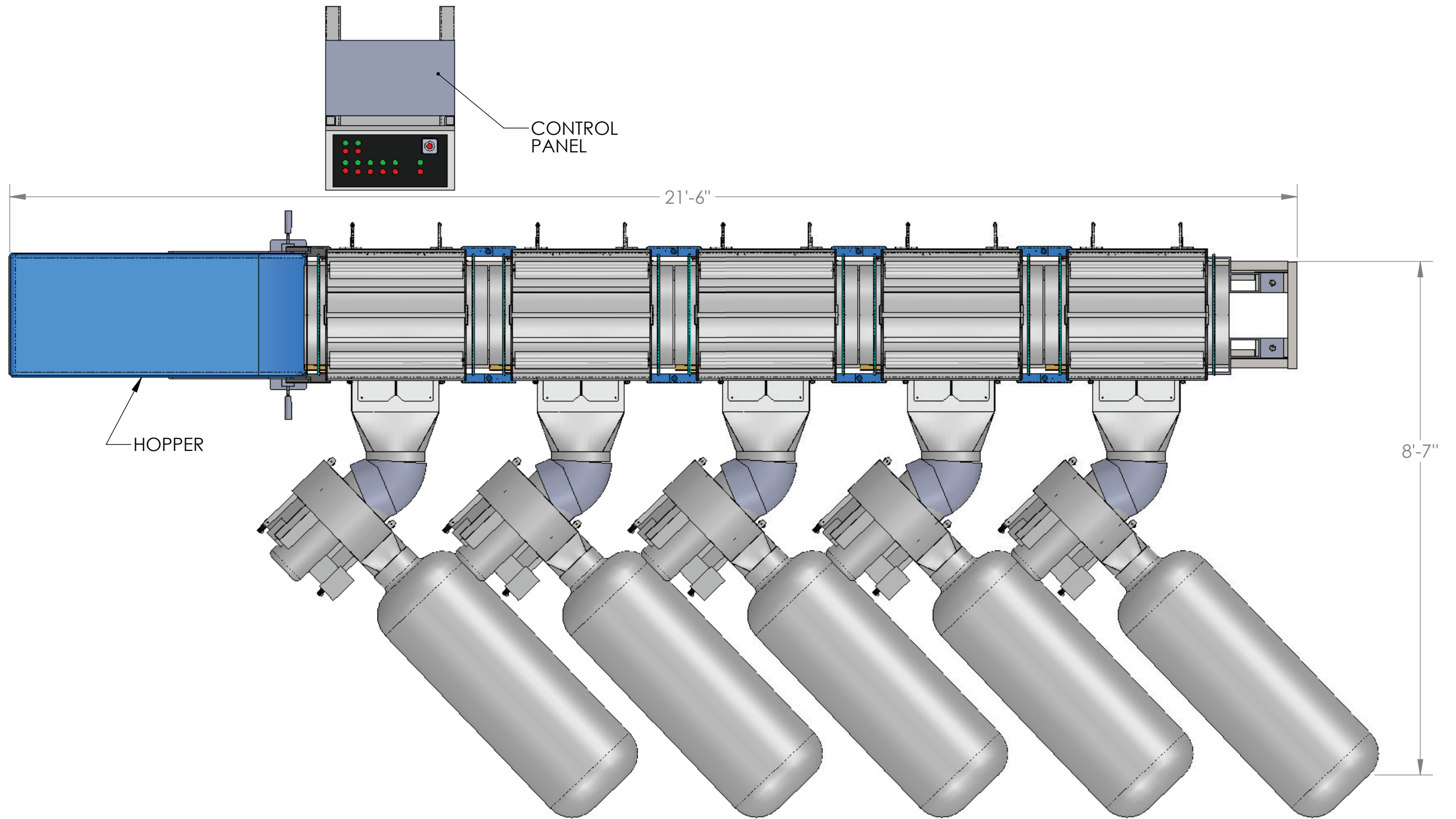

TITLE: XL 5.0 SE SYSTEM

UNLESS OTHERWISE SPECIFIED:
 DIMENSIONS ARE IN INCHES
 TOLERANCES:
 FRACTIONAL ±0.030
 ANGULAR: MACH ± 1° BEND ±
 TWO PLACE DECIMAL ±.010
 THREE PLACE DECIMAL ±.005

SIZE	DWG. TOP.	REV
A	5.0 Complete + Hopper	-

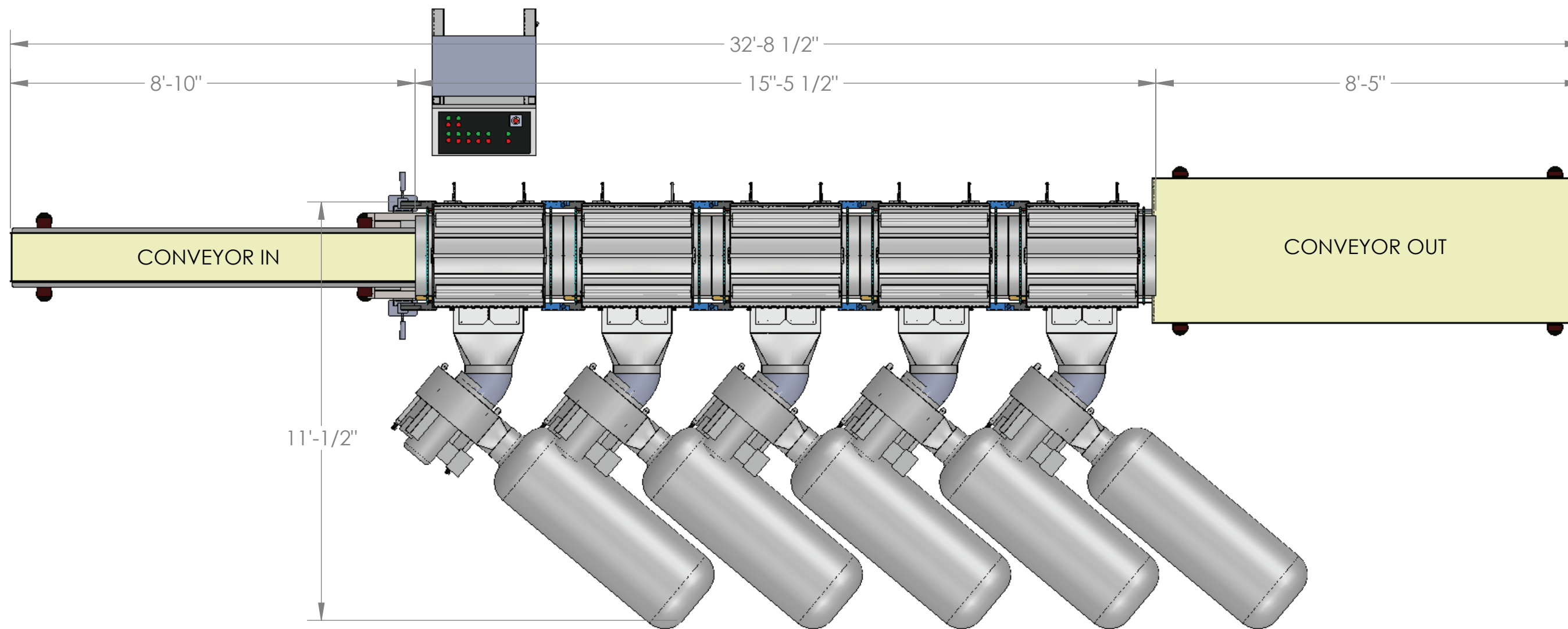

UNLESS OTHERWISE SPECIFIED:
 DIMENSIONS ARE IN INCHES
 TOLERANCES:
 FRACTIONAL ±0.030
 ANGULAR: MACH ± 1° BEND ±
 TWO PLACE DECIMAL ±.010
 THREE PLACE DECIMAL ±.005



TITLE: XL 5.0 SE SYSTEM

SIZE	DWG. TOP.	REV
A	5.0 Complete + Conveyors	-

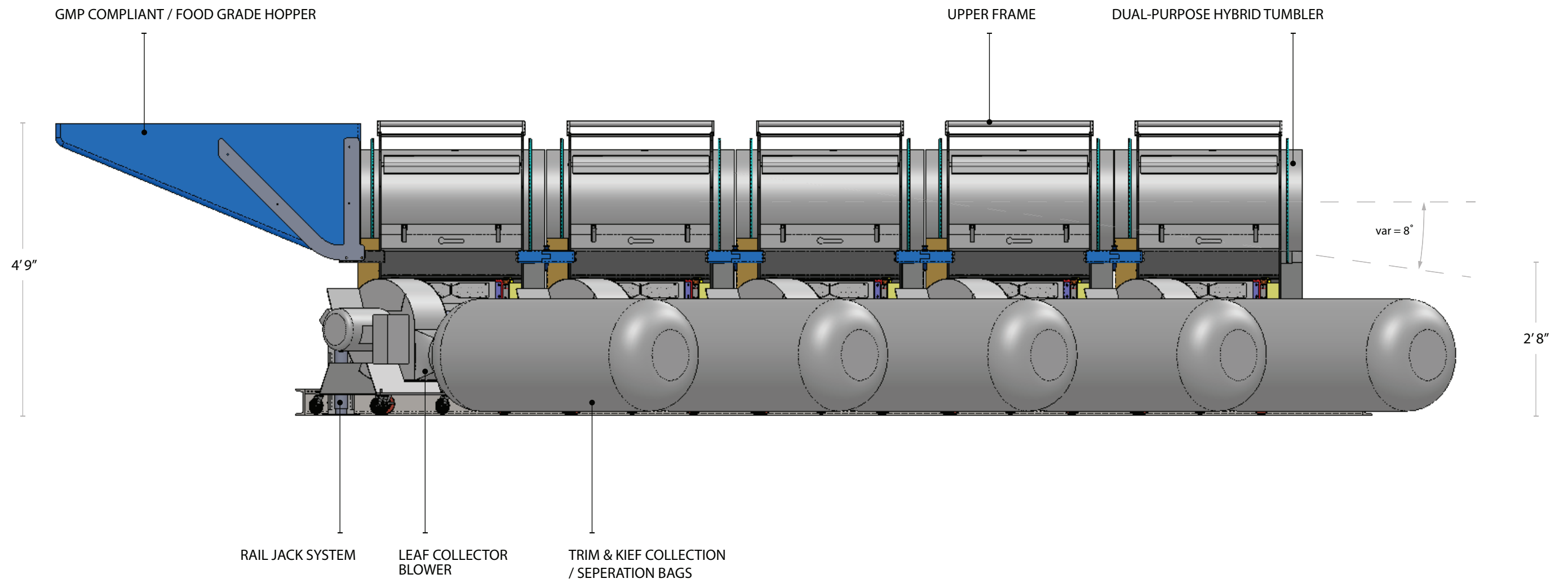

TITLE: XL 5.0 SE SYSTEM

UNLESS OTHERWISE SPECIFIED:
 DIMENSIONS ARE IN INCHES
 TOLERANCES:
 FRACTIONAL ±0.030
 ANGULAR: MACH ± 1° BEND ±
 TWO PLACE DECIMAL ±.010
 THREE PLACE DECIMAL ±.005

SIZE	DWG. SIDE.	REV
A	5.0 Complete + Hopper	-

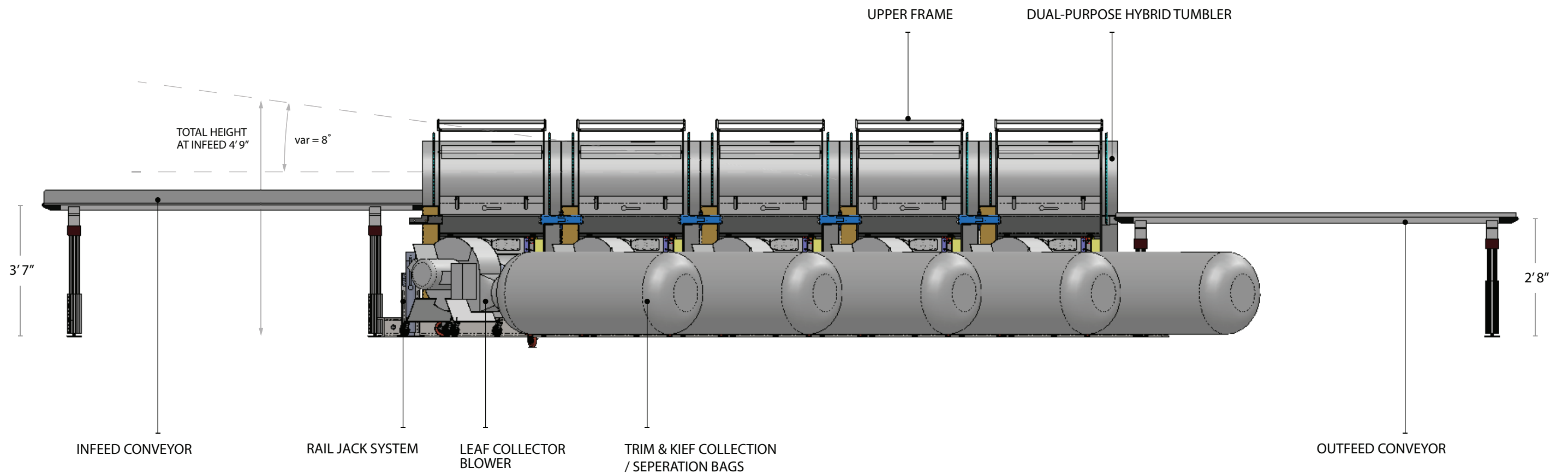

TITLE: XL 5.0 SE SYSTEM

UNLESS OTHERWISE SPECIFIED:
 DIMENSIONS ARE IN INCHES
 TOLERANCES:
 FRACTIONAL ±0.030
 ANGULAR: MACH ± 1° BEND ±
 TWO PLACE DECIMAL ±.010
 THREE PLACE DECIMAL ±.005

SIZE	DWG. SIDE.	REV
A	5.0 Complete + Conveyors	-