



CENTURIONPRO

HEMP & CANNABIS HARVESTING SOLUTIONS



TIMKEN
Where You Turn



BALDOR
MOTORS AND DRIVES

XL 10.0 - 60HZ MODEL

INFORMATION PACKAGE

XL 10.0 TRIMMER 60HZ - TECHNICAL DATA SHEET

The XL 10.0 system is an automated cannabis and hemp trimming system capable of high throughputs of wet or dry material. The system consists of multiple components and is composed of the following: XL 10.0 Trimmer, XL 10.0 HEPA Filter Leaf Collector Bags, XL 10.0 Blowers, XL 10.0 Infeed Conveyor, and XL 10.0 QC Conveyor.

SYSTEM FEATURES	XL 10.0
Throughput	Up to 3,000 lbs/hour Wet (600 lbs/hour Dry)
Power Requirements	3HP 220V 3-Phase 150Amp
Tumbler/Reel Motor	1HP 220V 3-Phase 3Amp
Vac Motor	5 x 8HP 220V 3-Phase 21Amp
Infeed Conveyor Motor	2 x 0.5HP 220V 3-Phase 1.6Amp
Quality Control Conveyor Motor	0.75HP 220V 3-Phase 3Amp
Cutting System	Belt Drive System 20 x 11 Blade Cutting Reels (26")
Tumbler Diameter	20 Inch
Effective Cut Length	520 Inch
Trim Separation	Triple Bag Kief & Trim Collection System
Lifting Mechanism	Manually Actuated to 10°
Food Grade	Yes
Washdown rating	IP65
RoHS compliant	Yes
Automation	Schneider Automation
Primary Material	Stainless Steel and Anodized Aluminum
Electrical Safety	CSA

1. Both values are the input rates for bucked material. Wet material denotes fully hydrated, dry material denotes 9-13% moisture content.

Based on tested values conducted by CPro Solutions Inc.

2. Machine also available as 50Hz model

3. 220V system has CSA certification only (pending)

XL 10.0 TRIMMER 60HZ - TECHNICAL DATA SHEET

MATERIAL SPECS	XL 10.0
Frame	304 Stainless Steel and Anodized Aluminum
Tumbler Screen	304 Stainless Steel
Blade Pivot Screws	304 Stainless Steel
Fasteners	304 Stainless Steel
Blades	Nitrided Carbon Steel
Bearings	Steel
Bearing Grease	Food Grade Grease
Fastener Grease	FDA-Approved Anti-Seize
Brush	Food Grade Nylon
Sheet metal body	Powder-Coated Steel
Flexible Ducting	FDA-Compliant Food Grade
Trim Collection	Triple Bag Kief & Trim Collection System
Conveyor Frame	304 Stainless Steel
Conveyor Belt	FDA-Compliant Food Grade
Hopper	Food Grade Plastic

XL 10.0 TRIMMER 60HZ - TECHNICAL DATA SHEET

BLADE / TUMBLER MOTOR SPECS	XL 10.0
Make	Baldor Industrial
Model	VEM35XX
Material	Stainless Steel Construction
HP	1HP (5-Motors Total, 5HP Total)
RPM (Full Load)	1,800 (1,760) RPM
Voltage	220V
Phase	3-Phase
Amps	3A
Frequency	60 Hz
Frame Size	56C
Mounting	Footed
Enclosure	TEFC
Full Load Running Current	12.4A
Locked Rotor Current	1.07A
Motor Efficiency (@ 100%)	85.8
Motor Efficiency (@ 75%)	85.4
Motor Efficiency (@ 50%)	82.9
Power Factor (@100%)	69
Power Factor (@75%)	60
Power Factor (@50%)	46
Full Load Torque	2.99 Lb.-Ft
Locked Rotor Torque (% of Full Load)	8.52 Lb.-Ft
Breakdown Torque (% of Full Load)	13.5 Lb.-Ft
Construction Materials	Stainless Steel

SCHEMATIC DRAWING - XL 10.0 TRIMMER 60 Hz with HOPPER

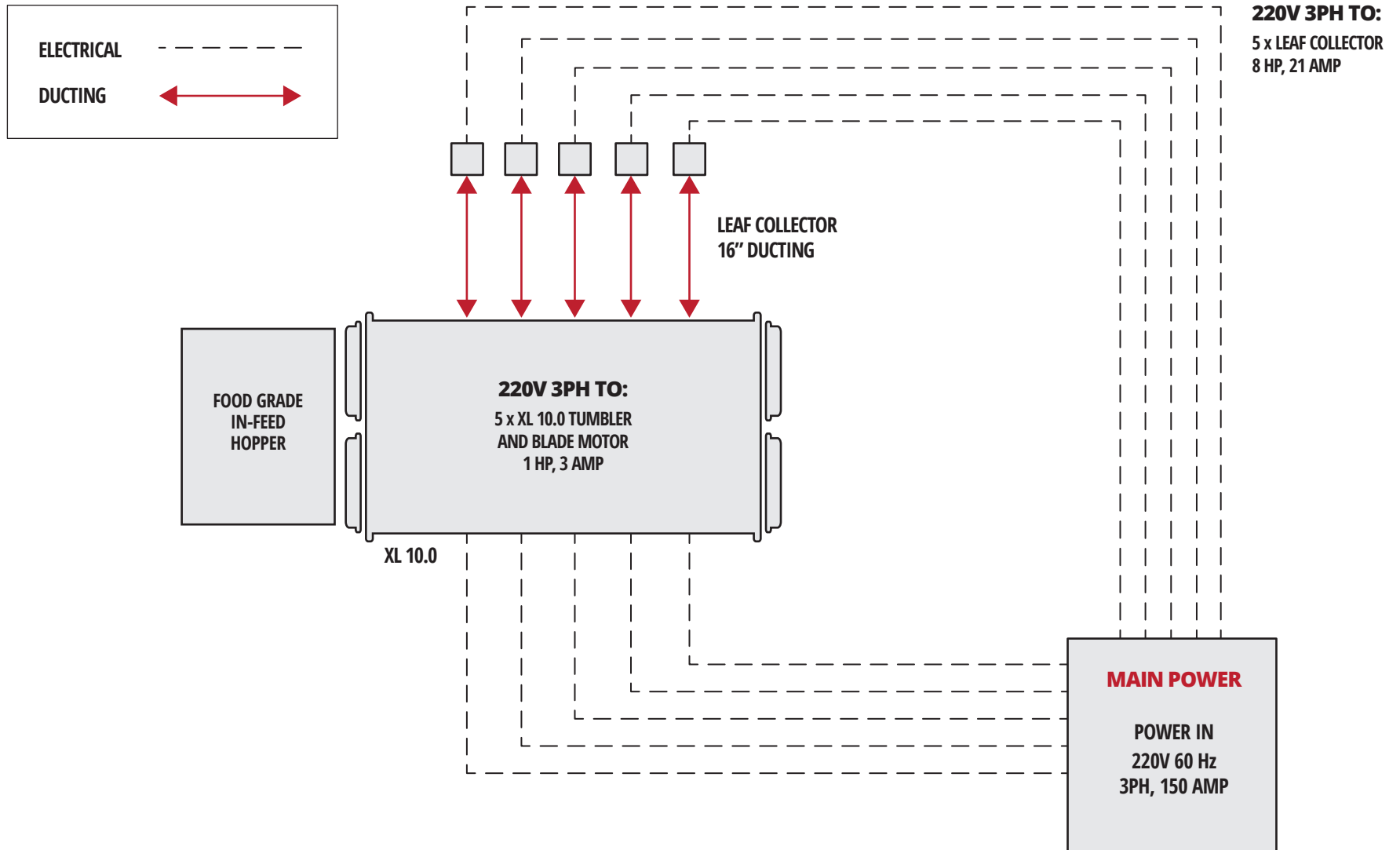

SCHEMATIC DRAWING - XL 10.0 TRIMMER 60 Hz with CONVEYORS

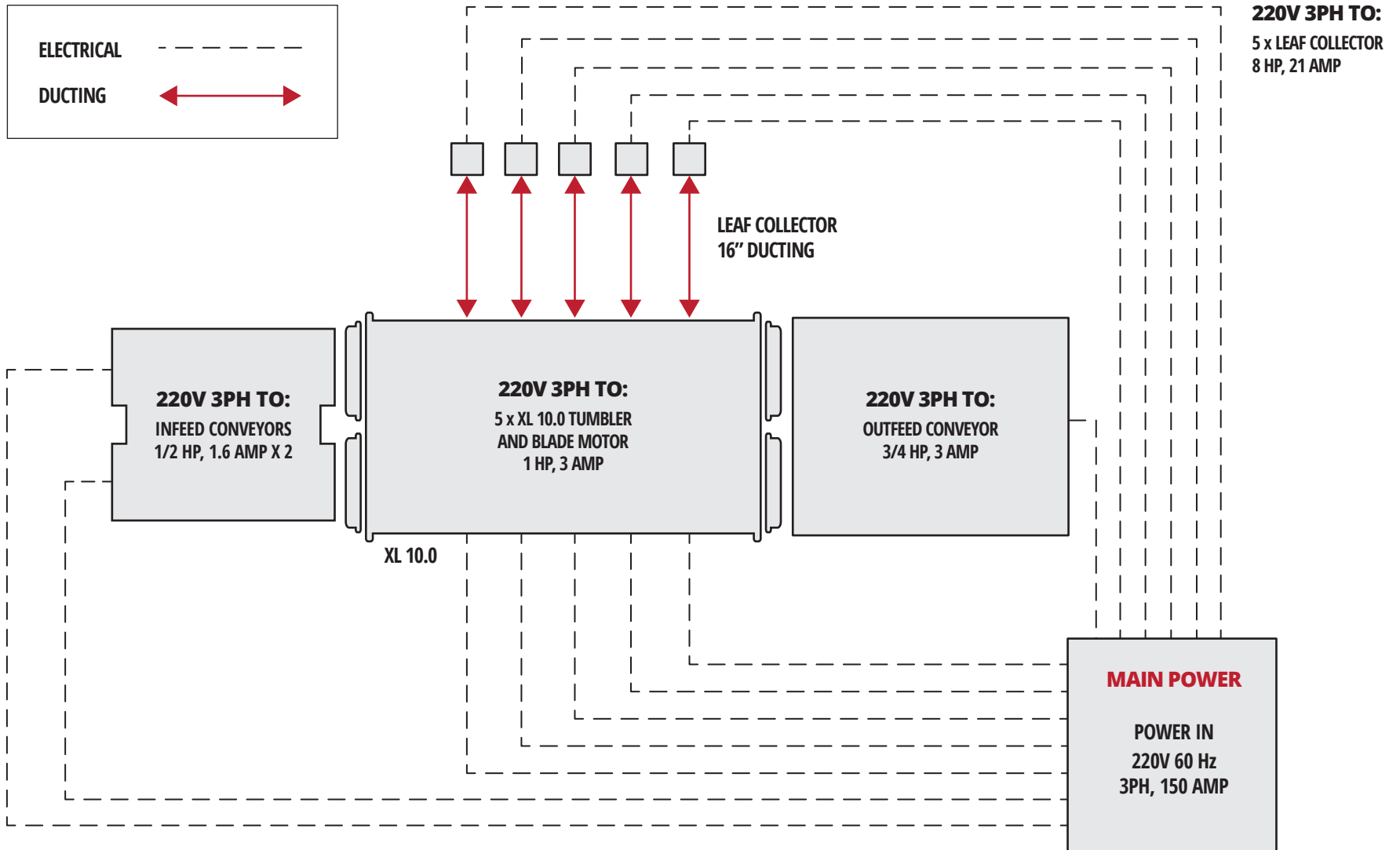



CENTURIONPRO

XL CONTROL PANEL

INFEED
CONVEYOR 1



ON

OFF

INFEED
CONVEYOR 2



ON

OFF

OUTPUT
CONVEYOR



ON

OFF



EMERGENCY STOP

BLOWER 1



ON

OFF

BLOWER 2



ON

OFF

BLOWER 3



ON

OFF

BLOWER 4



ON

OFF

BLOWER 5



ON

OFF



TRIMMERS



ON

OFF



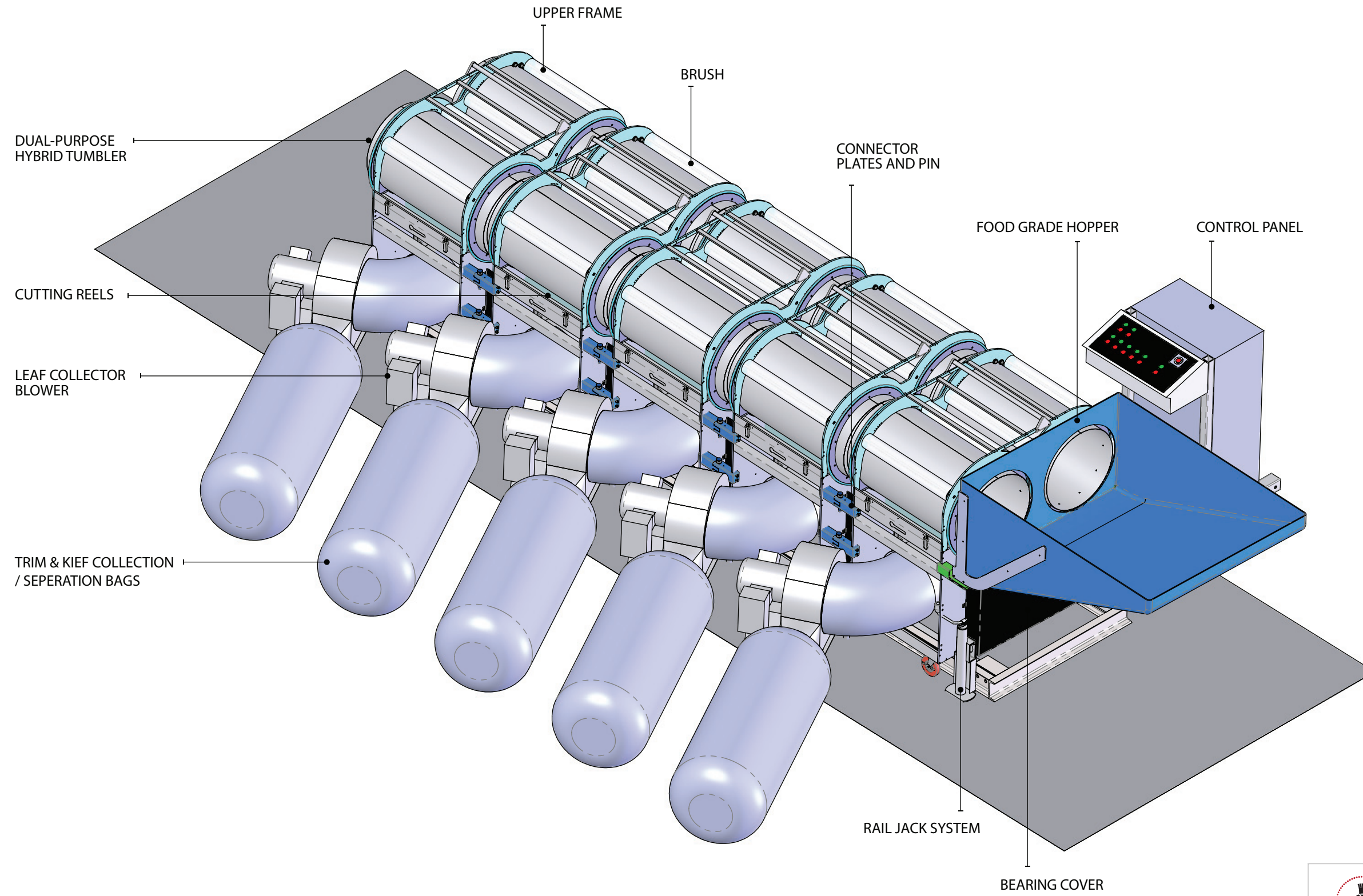

TITLE: XL 10.0 SYSTEM

UNLESS OTHERWISE SPECIFIED:
 DIMENSIONS ARE IN INCHES
 TOLERANCES:
 FRACTIONAL ±0.030
 ANGULAR: MACH ± 1° BEND ±
 TWO PLACE DECIMAL ±.010
 THREE PLACE DECIMAL ±.005

SIZE	DWG. 3-D.	REV
A	10.0 Complete + Hopper	-

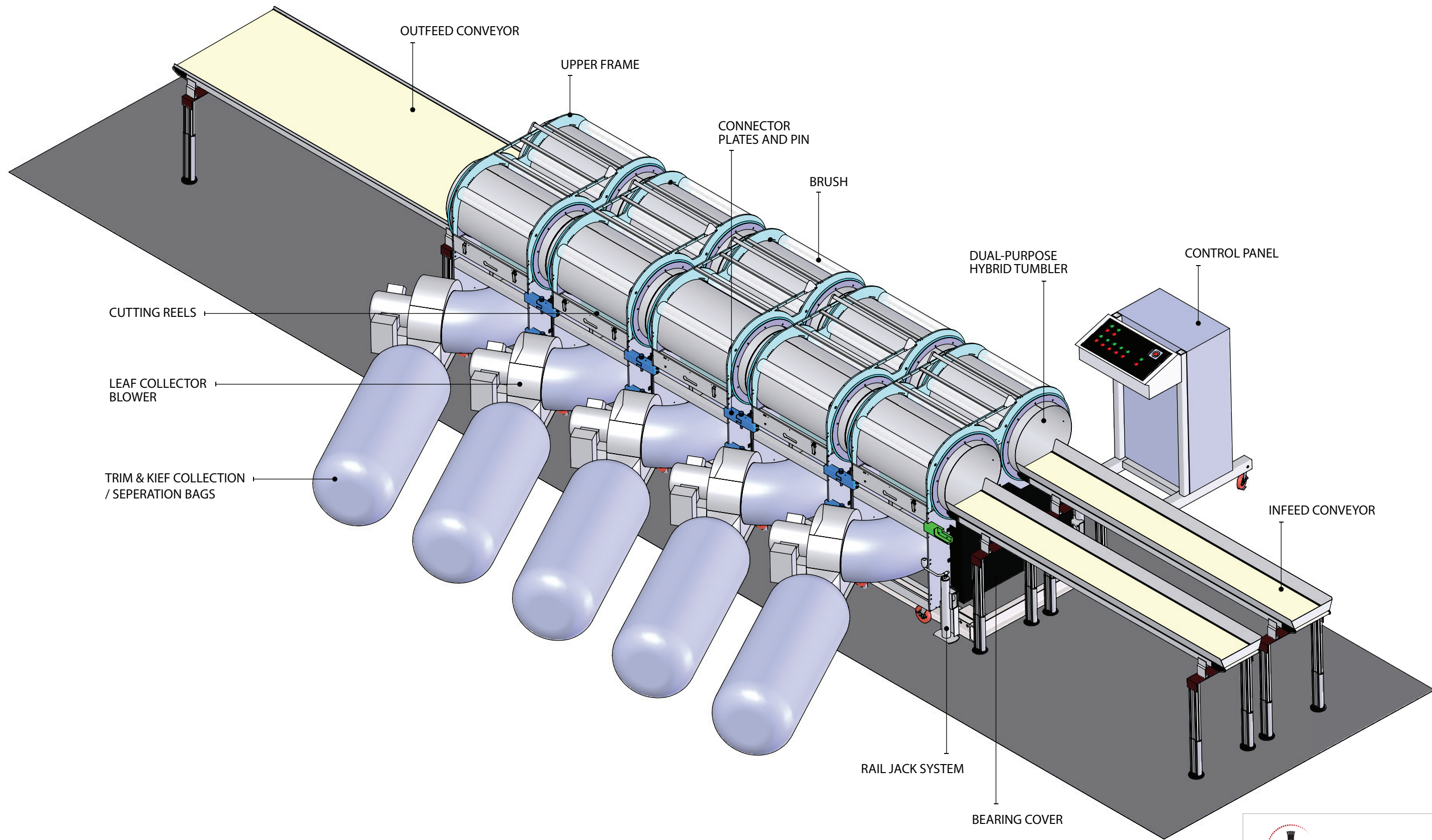

TITLE: XL 10.0 SYSTEM

UNLESS OTHERWISE SPECIFIED:
 DIMENSIONS ARE IN INCHES
 TOLERANCES:
 FRACTIONAL ±0.030
 ANGULAR: MACH ± 1° BEND ±
 TWO PLACE DECIMAL ±.010
 THREE PLACE DECIMAL ±.005

SIZE	DWG. 3-D.	REV
A	10.0 Complete + Conveyors	-

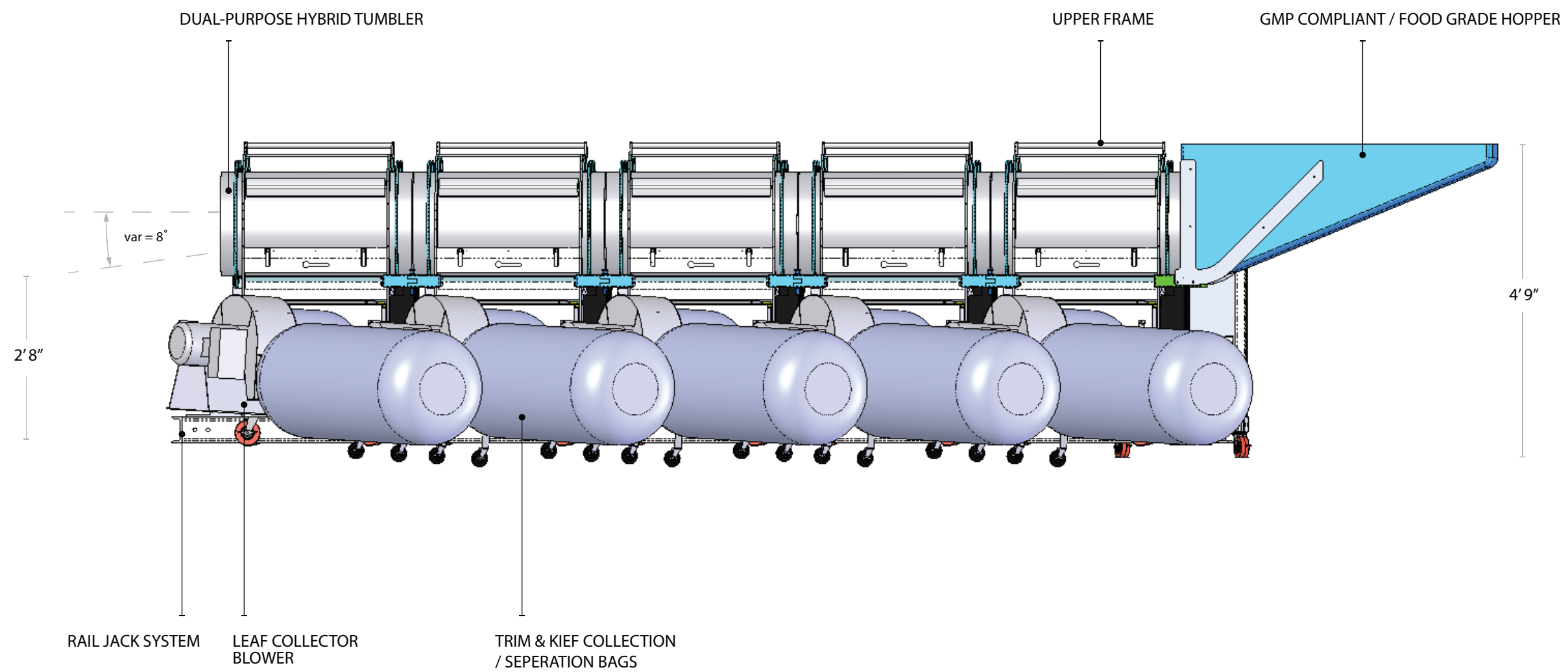

TITLE: XL 10.0 SYSTEM

UNLESS OTHERWISE SPECIFIED:
 DIMENSIONS ARE IN INCHES
 TOLERANCES:
 FRACTIONAL ±0.030
 ANGULAR: MACH ± 1° BEND ±
 TWO PLACE DECIMAL ±.010
 THREE PLACE DECIMAL ±.005

SIZE	DWG. SIDE.	REV
A	10.0 Complete + Hopper	-

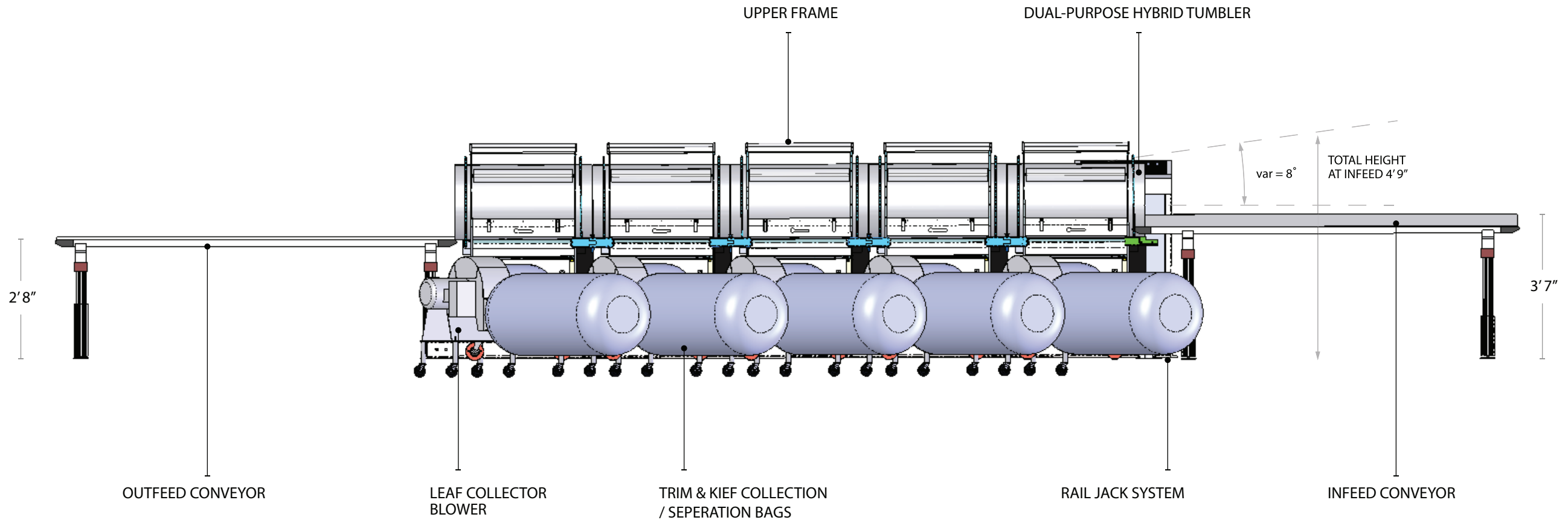

TITLE: XL 10.0 SYSTEM

UNLESS OTHERWISE SPECIFIED:
 DIMENSIONS ARE IN INCHES
 TOLERANCES:
 FRACTIONAL ±0.030
 ANGULAR: MACH ± 1° BEND ±
 TWO PLACE DECIMAL ±.010
 THREE PLACE DECIMAL ±.005

SIZE	DWG. SIDE.	REV
A	10.0 Complete + Conveyors	-

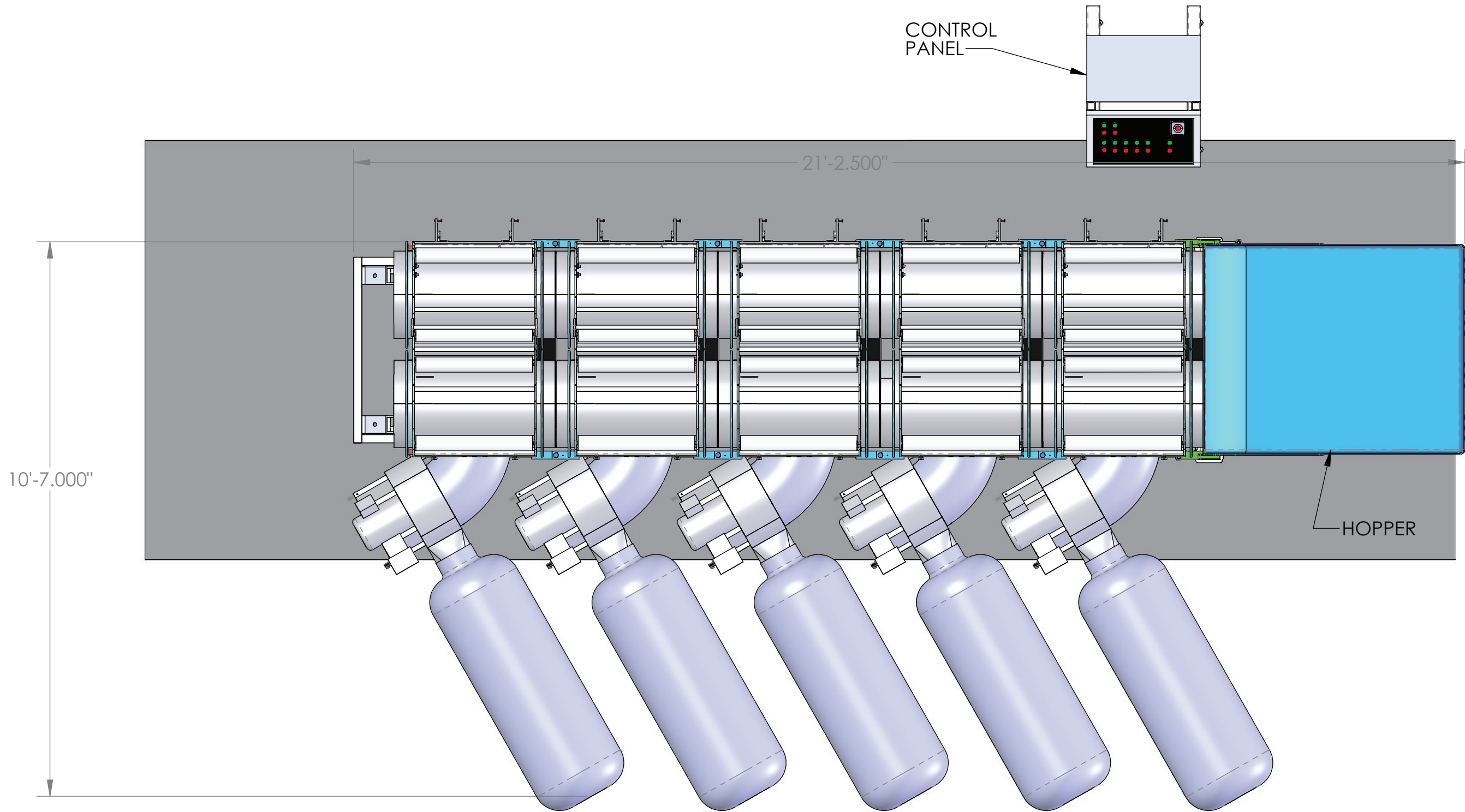

TITLE: XL 10.0 SYSTEM

UNLESS OTHERWISE SPECIFIED:
 DIMENSIONS ARE IN INCHES
 TOLERANCES:
 FRACTIONAL ±0.030
 ANGULAR: MACH ± 1° BEND ±
 TWO PLACE DECIMAL ±.010
 THREE PLACE DECIMAL ±.005

SIZE	DWG. NO.	REV
A	10.0 CS + H	-

SHEET 1 OF 1

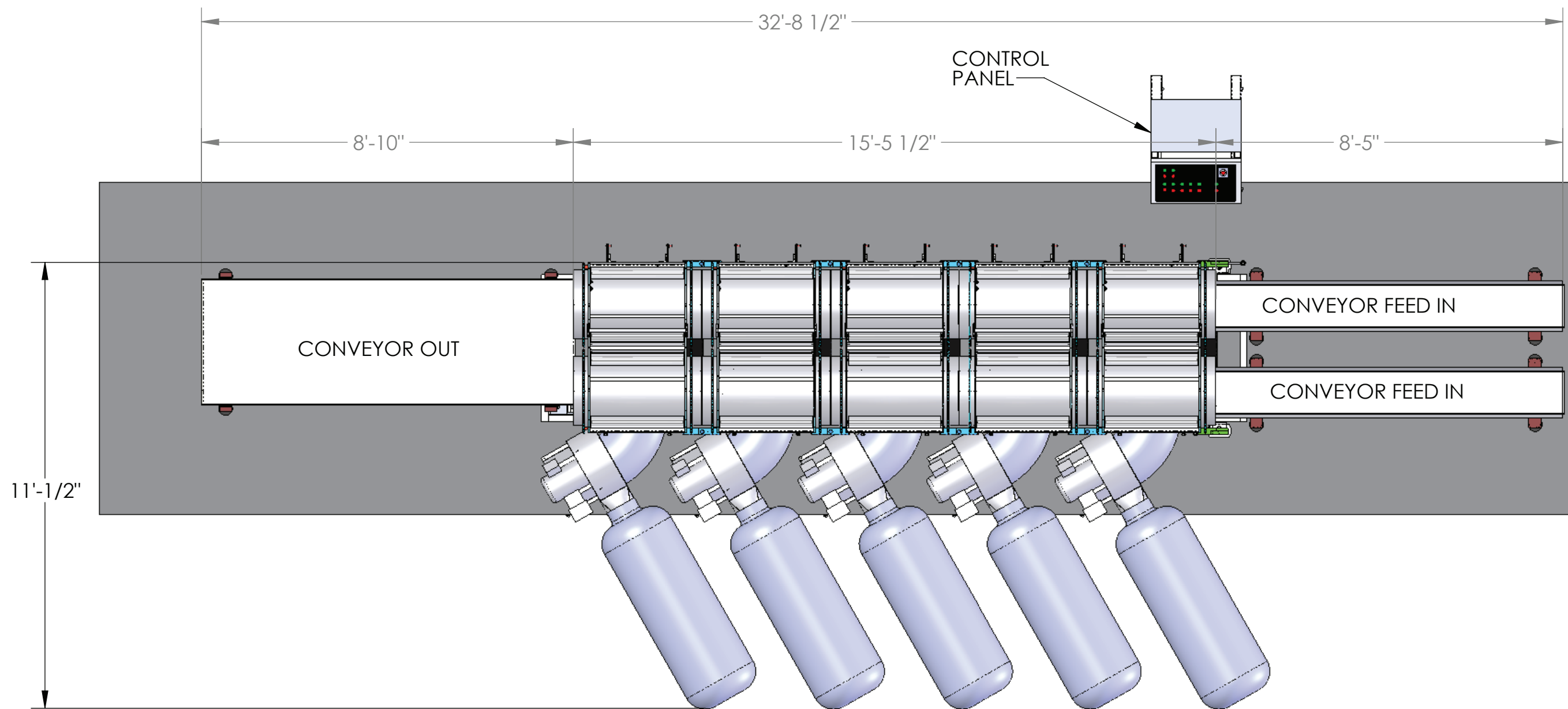

PLAN VIEW

UNLESS OTHERWISE SPECIFIED:
 DIMENSIONS ARE IN INCHES
 TOLERANCES:
 FRACTIONAL ±0.030
 ANGULAR: MACH ± 1° BEND ±
 TWO PLACE DECIMAL ±.010
 THREE PLACE DECIMAL ±.005



TITLE: XL 10.0 SYSTEM

SIZE	DWG. NO.	REV
A	10.0 CS + Conv	-