

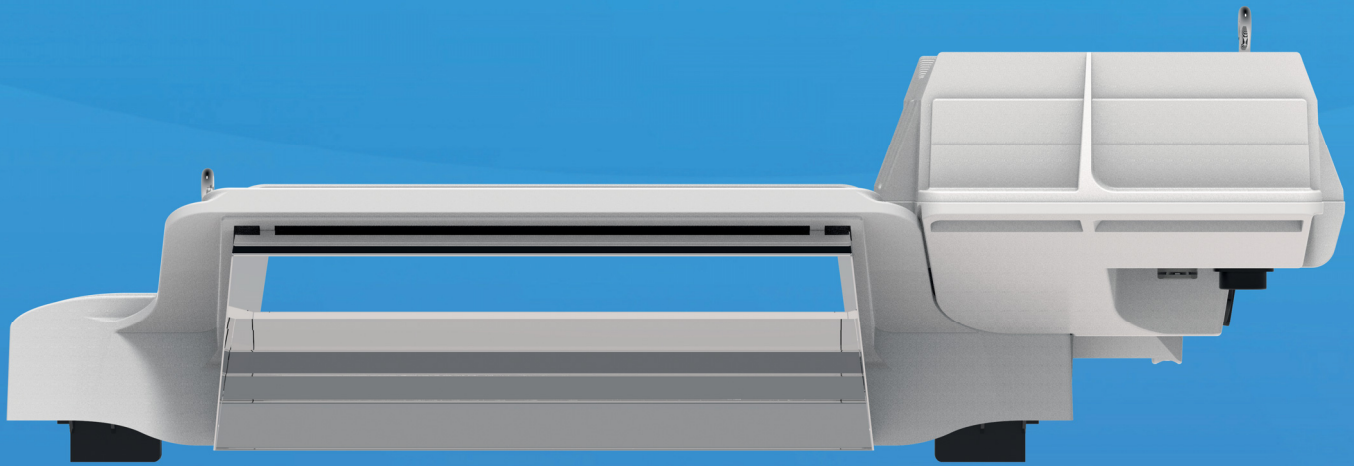

Dutch Lighting[™]
Innovations



DLI JOULE-Series 1000W DE 120/240V Fixture

Redefining
The Grow Light





Redefining The Grow Light

Dutch Lighting Innovations is an innovative company which develops and manufactures supplemental lighting systems for the global greenhouse industry. Our products are made with components of the highest quality and reliability and are very easy in maintenance.

With over 25 years of experience in development, production and sales of fixtures in the global greenhouse industry, the DLI team have redefined the lighting fixture.

After working closely together with Philips Lighting for High Pressure Sodium and Metal Halide systems, DLI developed LED products for climatized rooms, multi-layer grow systems and Interlighting for vegetable growth.

Our HPS and LED Interlight products can either be used as stand-alone systems or as a hybrid system to achieve the highest yields and to improve the growers return on investment.

DLI's mission is to always create a fixture that surpasses the performance of the competitors, whilst improving the design to suit the purpose. This new approach to design has made way for numerous improvements in the light fixtures design and functionality.

“DLI’s mission is to always create a fixture that surpasses the performance of the competitors, whilst improving the design to suit the purpose.”

DLI can help with a customized lighting plan for your greenhouse or facility that match the requirements of your crop and light level and provide you with a comprehensive solution. With the experience of our team members we can help you with advise best fit for your company.

Exclusive μmol output

The new Dutch Lighting Innovations JOULE-Series 1000W fixture is designed for the DLI Horticulture Plus 1000W DE Lamp.

This lamp is optimized by DLI to increase photosynthesis efficiency in flowering plants. By enhancing the gas chemistry of the lamp the output maintains high life.

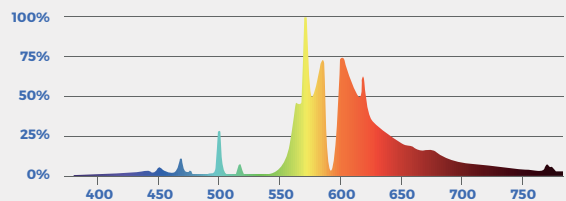
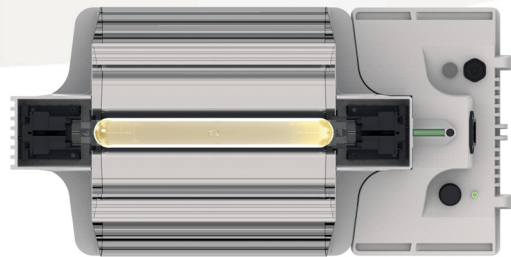

OUR CORE VALUES



RESEARCH & DEVELOPMENT



INNOVATION IN DESIGN



QUALITY & LONGEVITY



CONSTANT IMPROVEMENT



CUSTOMER SATISFACTION

The DLI JOULE-Series 1000W fixture comes with a 3 year warranty.



Time for Improvement For Decades

...growers have settled for lighting options that are not 100% tailored for their use and crop. Grow light manufacturers are always trying to appease the mass populations of growers, rather than honing in on exactly what they need for optimal performance, yields, and most important quality.

Dutch Lighting Innovations presents the JOULE-series 1000w DE system. This proprietary engineered design has reset the bar for indoor production specifically.

The engineering principles behind the DLI Open Reflector are a culmination of over a decade of research and development. The team works with a ranging group of some of the best horticulturists around the globe; each who specialise in plant and varietal specific production processes for the ornamental, and commercial flower market. Dutch Lighting Innovations has allowed these groups a new level of consistency, reliability, and quality unparalleled in the niche world of growing the best flowers and plants on Earth!

The DLI reflectors are manufactured to have the highest possible total reflectance at all wavelengths from 400 to 700 nm giving excellent PAR rendition. The integrated hemispherical reflectance is over 95% with an absence of iridescence colours in the louvre.

The DLI reflectors are made from an electrochemically brightened high purity aluminium substrate coil, and start with an anodised base coat which gives a hard support to minimize abrasion damage. The material is then treated under vacuum with specially developed processes to maximise coating adhesion and is vacuum coated with a super pure reflection layer of 99.99% pure aluminium.

These reflection layers are overlaid with a dual layer oxide system tuned for maximum visible reflection enhancement. This serves to increase the overall reflectivity provided by the metallic layers and adds protection against damage.

Efficiency and uniformity have been the main focus in the development of the Flowers-only reflector. Each ray of light coming from the lamp will either be transmitted directly to the plants or will only hit the 99.99% pure aluminium once before being transmitted to the plant. The unique design of the DLI reflector and the high uniformity of light the reflector projects results in less hotspots on the canopy and a more even plant growth.

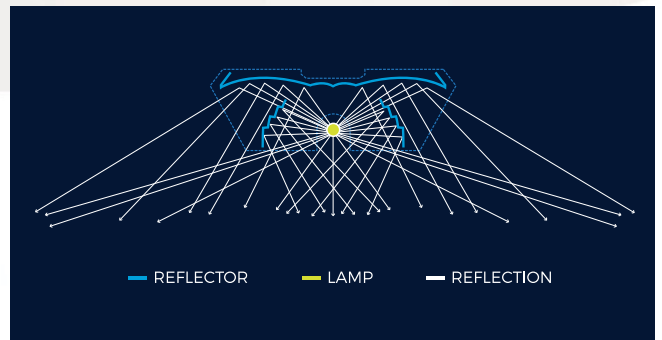

- Extra Low-Profile Housing**
Ideal for low ceilings
- Improved Reflector**
Superior Light Spread & Reflection
- Improved Heatsink**
Increased Driver Efficiency
- LED Indicator**
Status & Error Diagnostics
- Dim Switch Dial**
Dimmable to 600W - 750W
- 825W - 1000W - 1150W
- IP65 Controller Connection**
Plug & Play with DLM-Series
- Core-Tex Plug**
Ventilation Plug
- Built in Spirit Level**
Achieve Perfectly Even Light Spread



DLI JOULE-Series 1000W DE 120/240V

Technical Specifications

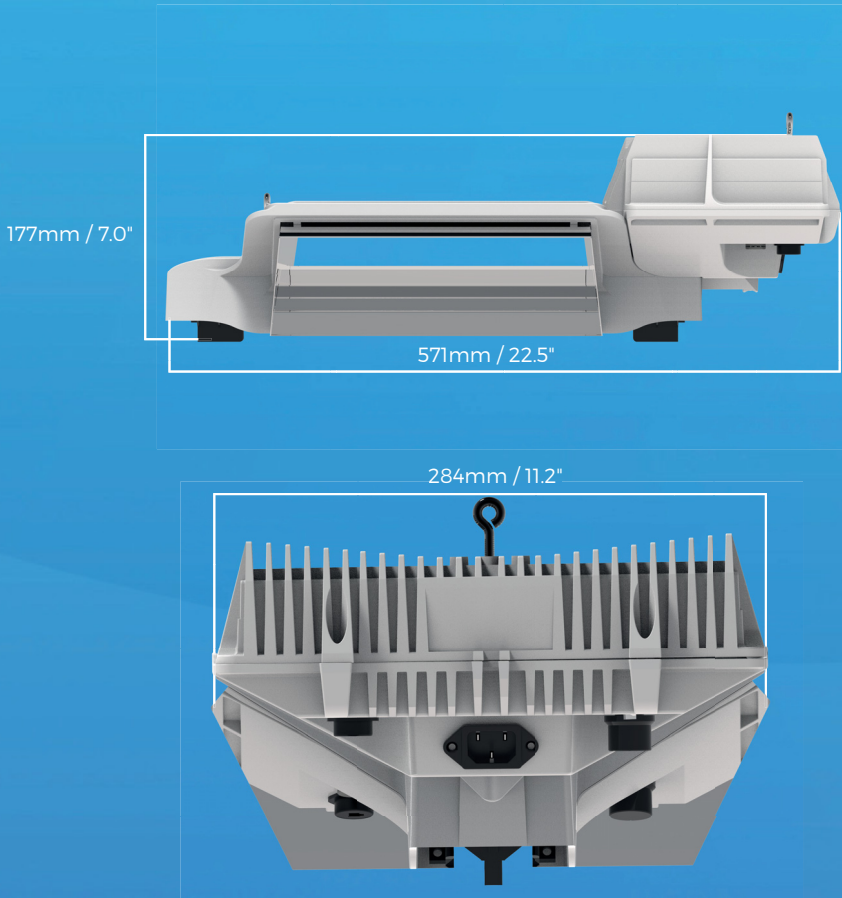

DLI JOULE-Series 1000W DE 120/240V

INPUT VOLTAGE:	120 - 240V
INPUT VOLTAGE RANGE:	± 10%
RATED POWER:	1045W
DIMMING WITH SWITCH:	600W - 750W - 825W 1000W - 1150W
DIMMING WITH CONTROLLER:	600W - 1150W
FREQUENCY:	50/60 HZ
TYPICAL CURRENT:	4.4A @ 240V/1000W
MAXIMUM CURRENT:	10A @ 120V/1150W
INRUSH CURRENT:	≤ 40A
POWER FACTOR:	≥ 0.98
DIMENSIONS:	571 X 284 X 178mm 22.5 X 11.2 X 7.0 INCH
WEIGHT:	7.5 KG / 16.5 LBS

Also Available from Dutch Lighting Innovations:

DIODE-Series
Interlighting Fixture



DLM-4 Zone
Daily Lighting Management



DLI JOULE-Series 315W
315W LEC Fixture



Dutch Lighting™
Innovations