

Wallcovering  
Wall Protection  
Upholstery  
Paint  
Wink<sup>®</sup>  
Digital  
Wood  
Acoustical

GATHER<sup>®</sup> Acoustical

**GATHER<sup>®</sup>**  
ACOUSTICAL

# Contents

3 GATHER Together

**5 Design**

**37 Acoustics**

**43 Installation and Hardware**

48 Care and Maintenance

49 Sampling and Support

50 Where We Gather

51 Remember...

52 About Wolf-Gordon

Shrine

Dimensional: Folding  
(double layer)

Charcoal GATH 706

# GATHER Together

**It is truly human to gather! We are grateful for our interior communities in the workplace and schools, performance spaces, restaurants, and hotels. More than ever before, a heightened sensibility to acoustical comfort is integral to the design of interiors that make people feel good. When noise is mitigated, stress levels decrease, and we tend to communicate and collaborate better.**

**GATHER® Acoustical** is an ingenious set of materials that render noise levels more comfortable for the changing dynamics of commercial interiors. Noise reduction coefficients (NRC) are the standard for measuring how much sound a surface absorbs and reflects. An NRC of 0.0 indicates that a surface doesn't absorb any sound and that 100% of the sound reflects back into a space. This results in noisy, disturbing rooms in which conversations and meetings are unpleasant. At the other end of the spectrum, an NRC of 1.0 indicates that the material absorbs 100% of the sound. The NRCs for GATHER range from 0.25 to 0.90 depending on the pattern, technique, single or double layering, and distance from a wall. The Acoustics section of this catalog, beginning on page 37, goes into depth on GATHER's performance and how it improves life in the places we meet.

GATHER enables designers to think more creatively when choosing finishes to define an interior. The standard 4' x 10' acoustical panels are lightweight and offered in an array of heathered and saturated colors. Production techniques such as digital printing, V-groove engraving, precision cutting, and origami-like dimensional modules are available. The panels can be applied directly to walls, layered in different color and pattern combinations, or installed with a hardware system for use as screens or partitions.

GATHER® Acoustical Materials are made from 60% post-consumer and 40% pre-consumer recycled polyester. The material contains no heavy metals, phthalates, perfluorinated compounds, formaldehyde, or urea, meeting the Living Building Challenge Red List criteria and earning the Oeko-Tex® Standard 100 "Confidence in Textiles" label. GATHER has also been tested for emissions, yielding low VOCs as per the "Standard Method Version 1.2" of CDPH 01350. In the interest of transparency and requirements for green building projects and LEED certification, GATHER product information and ingredients are disclosed on the Declare platform, and a Health Product Declaration (HPD) can be found at [wolfgordon.com](http://wolfgordon.com).

### How is Noise Reduction Measured?

An acoustical product's performance is measured by how much sound a surface absorbs—this is called the Noise Reduction Coefficient or NRC.

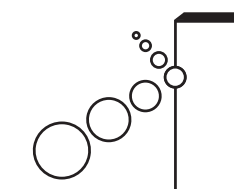

#### 0.0 rating—Worst

A zero rating means that a material absorbs 0% of the sound energy that reaches it and reflects 100% back.

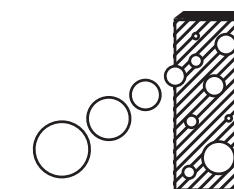

#### 1.0 rating—Best

A 1.0 rating means that a material absorbs 100% of the sound energy that reaches it and reflects 0% back.



Morgan

V-Groove Engraving  
(single layer)

Thunder GATH 703



# Design



# The Texture of Felt

The process used to create **GATHER® Acoustical** panels results in a lightly heathered appearance and felted feel. Measuring 1/4" (6mm) thick, the standard 4" x 10" panels can be adhered to

walls as a single or double-layer design—or used to divide a space. And, the material is pliable enough to be folded into shapes, as in our *Shrine* design, or woven in strips, as in our *Basket* design.

# Color

**GATHER® Acoustical** materials are offered in 12 solution-dyed colors, and the 4' x 10' solid panels can be used to create a homogenous

wall or divide a space. The material can also be field-cut into tiles to form a variety of geometric compositions.



Escher

V-Groove Engraving  
(double layer)

Fog GATH 704  
Obsidian GATH 710

# Technique

**GATHER** helps create rooms with distinctive and textured focal points, wall treatments, or space dividers. Patterning is realized through the following techniques:

- Digital Printing
- V-Groove Engraving
- Precision Cutouts
- Dimensional Folding and Weaving

# Technique Digital Printing

Enliven a space while improving acoustics with graphic imagery that is digitally printed on **GATHER**. In addition to the designs shown here, you can have custom panels produced from photographs, logos, or artwork you provide, or choose images from our Curated Collection.



Brady

Digital Printing

Digitally printed  
on Sandstone GATH 702



Transporter

Digital Printing

Digitally printed  
on Snow GATH 711





# Technique V-Groove Engraving

These linear patterns offer a lively appearance along with acoustical benefits. Single or double-layer **GATHER** panels are set on a CNC router table where the pattern is engraved into the material. The CNC routing bit creates a V-shaped cut that is scored into the material at a partial depth or cut through the material to reveal the bottom layer or substrate. Some designs incorporate the V-groove along with the Cutout technique.



Gregori

V-Groove Engraving  
(single layer)

Putty GATH 705



Club

V-Groove Engraving  
(double layer)

Charcoal GATH 706  
Thunder GATH 703



Bouquet

V-Groove Engraving  
(single layer)

Bluestone GATH 707

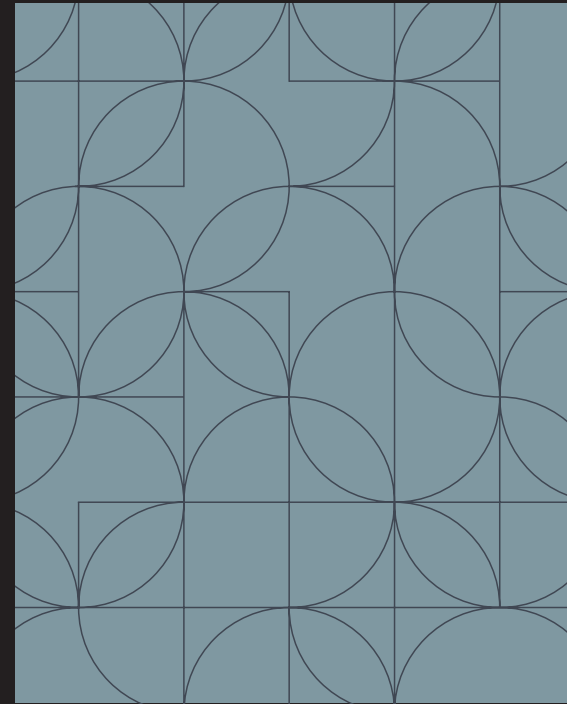
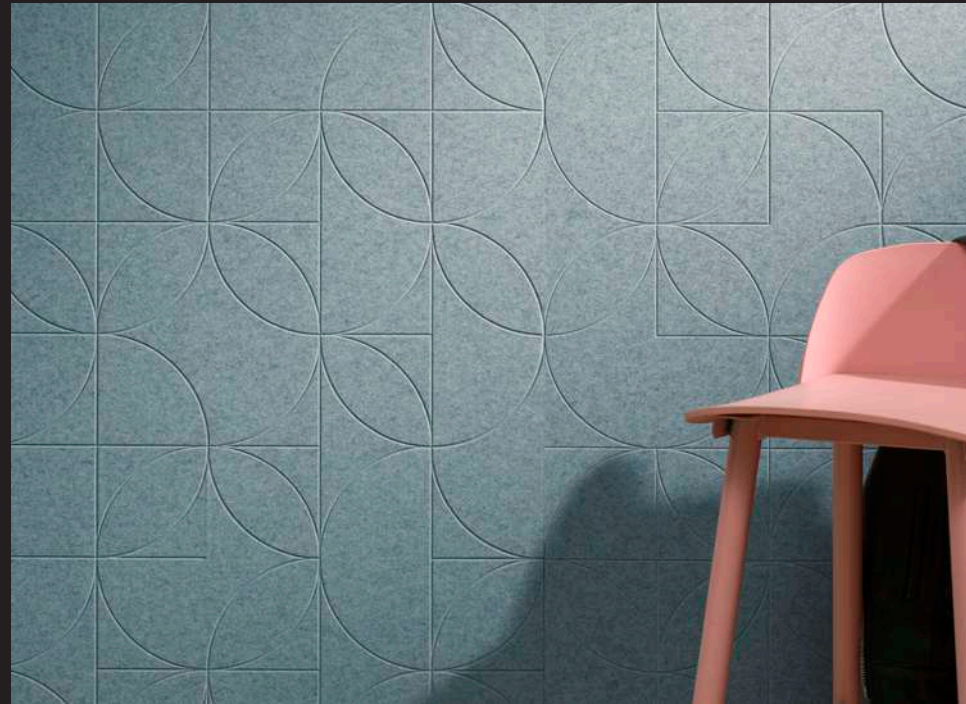

Morgan

V-Groove Engraving  
(single layer)

Thunder GATH 703

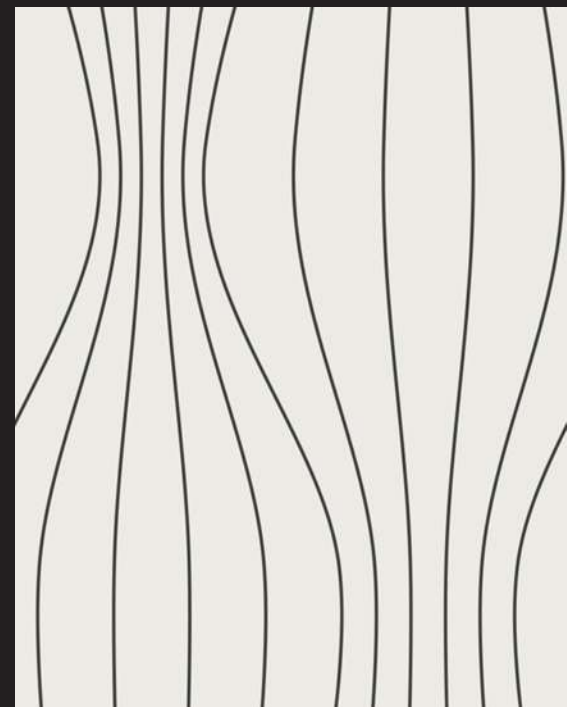

Morgan

V-Groove Engraving  
(single layer)

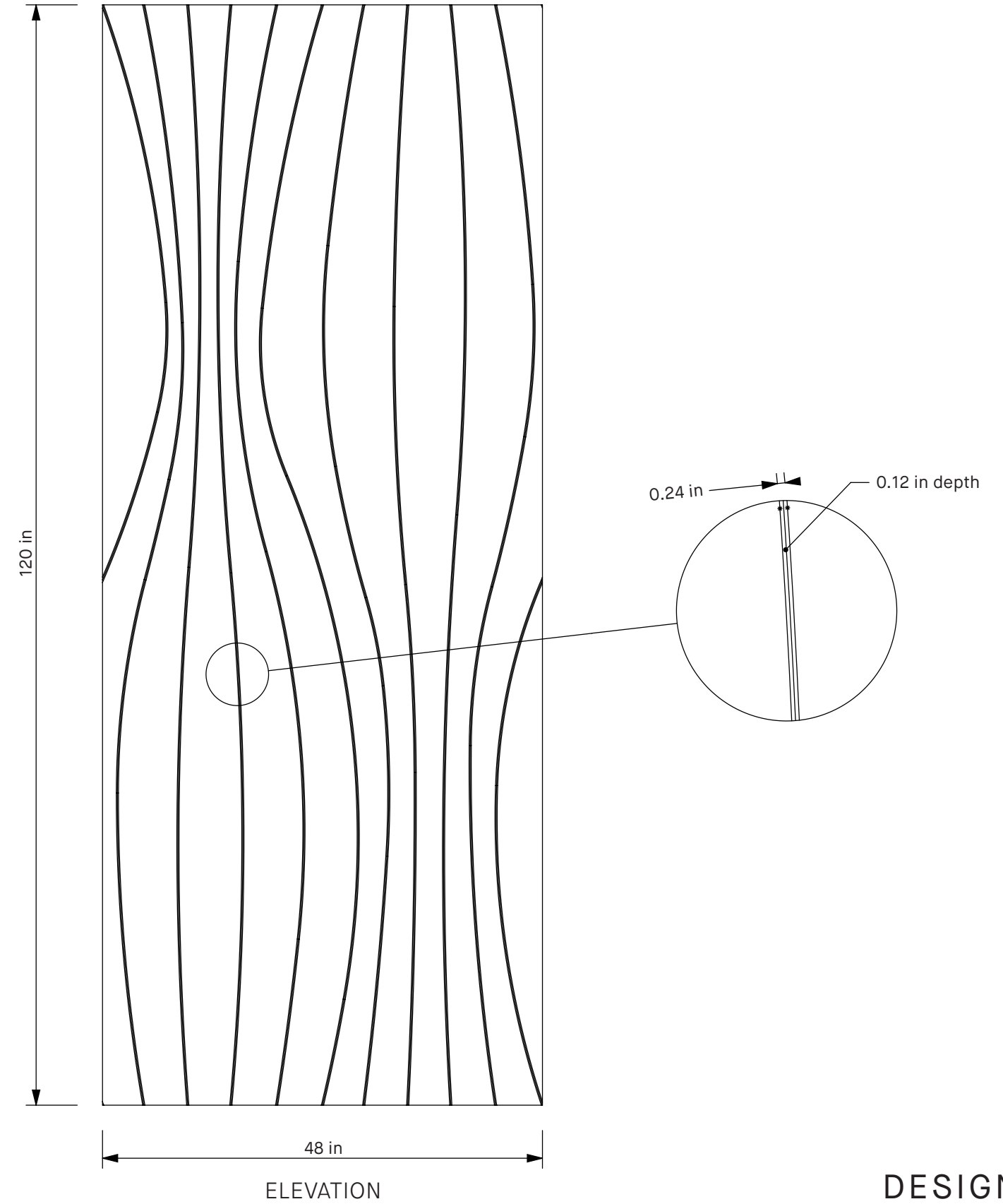

Dottie

Precision Cutouts  
(double layer)

Fog GATH 704  
Charcoal GATH 706

# Technique Precision Cutouts

Create a unique look for walls or partitions with these **GATHER® Acoustical** patterns, cut directly into solid color panels with a CNC routing system. The precision-cut patterns can be laminated to a base layer of the same or different color to create a double-thick (1/2") panel, which also increases the NRC rating.



Ella

Precision Cutouts  
(double layer)

Charcoal GATH 706  
Sandstone GATH 702



Dottie

Precision Cutouts  
(double layer)

Sandstone GATH 702  
Thunder GATH 703

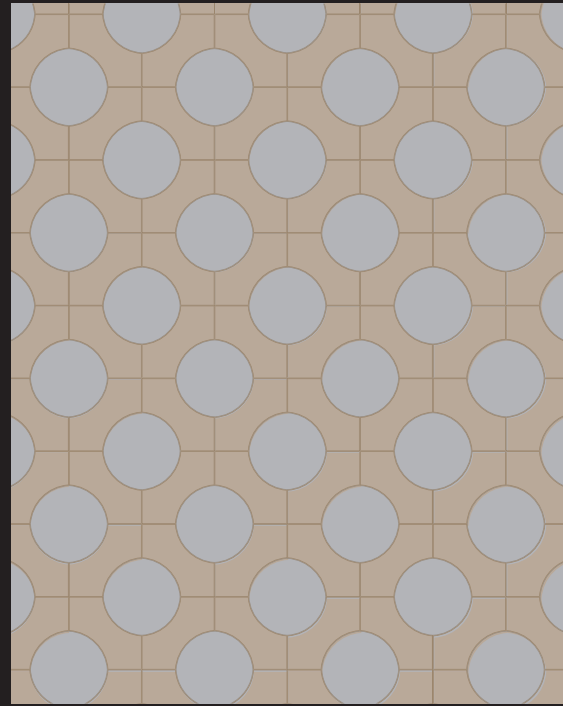

Intrepid

Precision Cutouts  
(double layer)

Thunder GATH 703  
Royal GATH 708

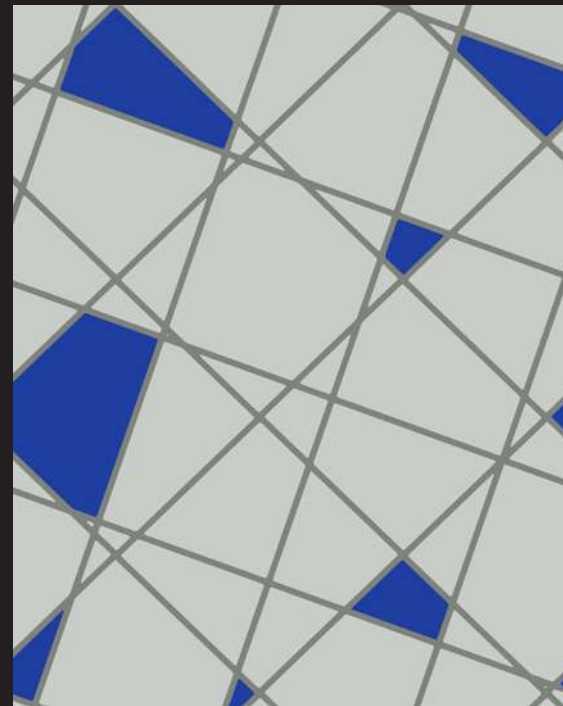
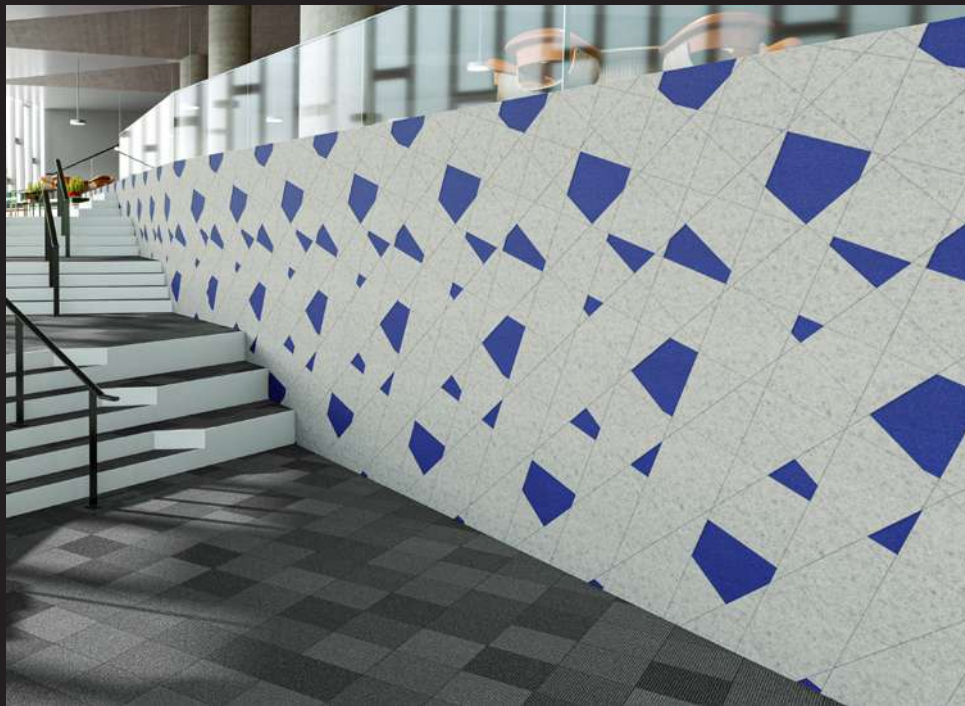

Dottie

Precision Cutouts  
(double layer)

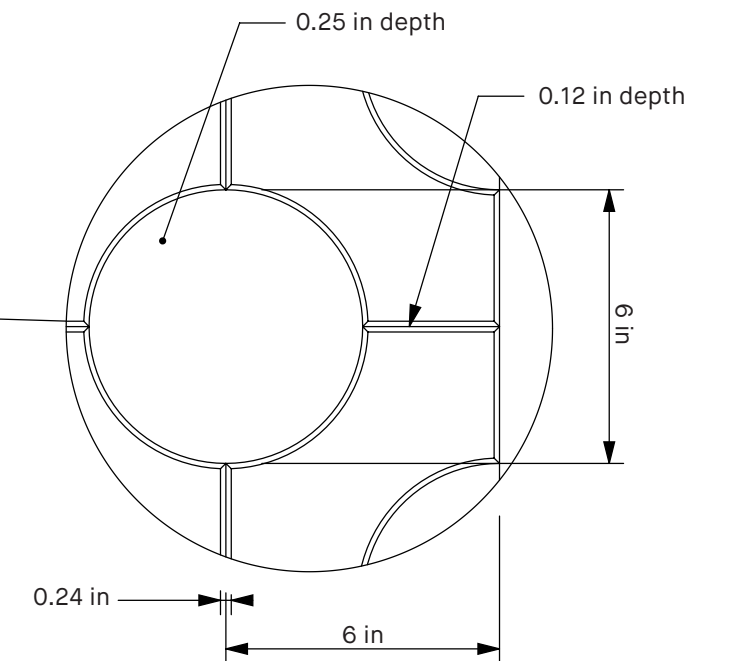
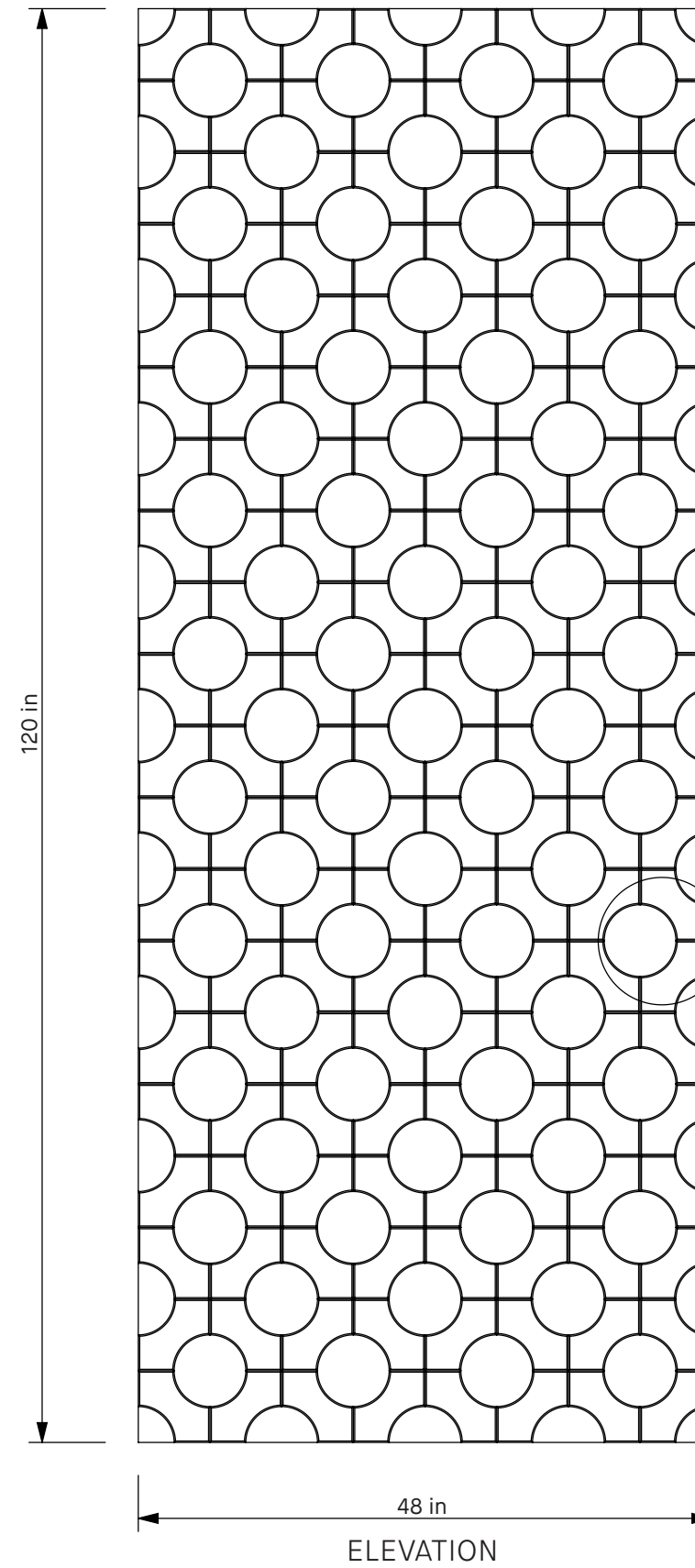

Shrine

Dimensional Folding  
(double layer)

Charcoal GATH 706

# Technique Dimensional: Folded

Our **GATHER**® three-dimensional modules provide both acoustic diffusion and sound absorption. Shapes cut from the material are scored so they can be folded like origami. Each shape has tabs that lock into slots that are cut out of a base panel. These shapes project from the base for a dynamic visual effect.

Rafter

Dimensional Folding  
(double layer)

Putty GATH 705





Dimensional Folding  
(double layer)

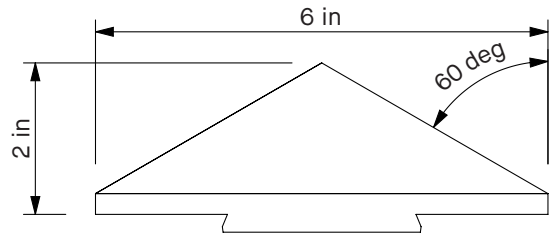

PART SIDE

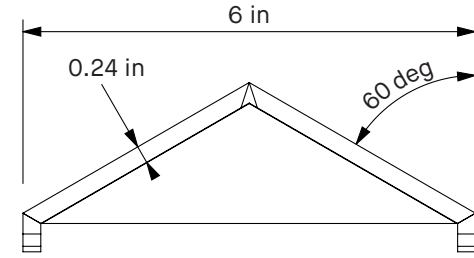

PART ELEVATION

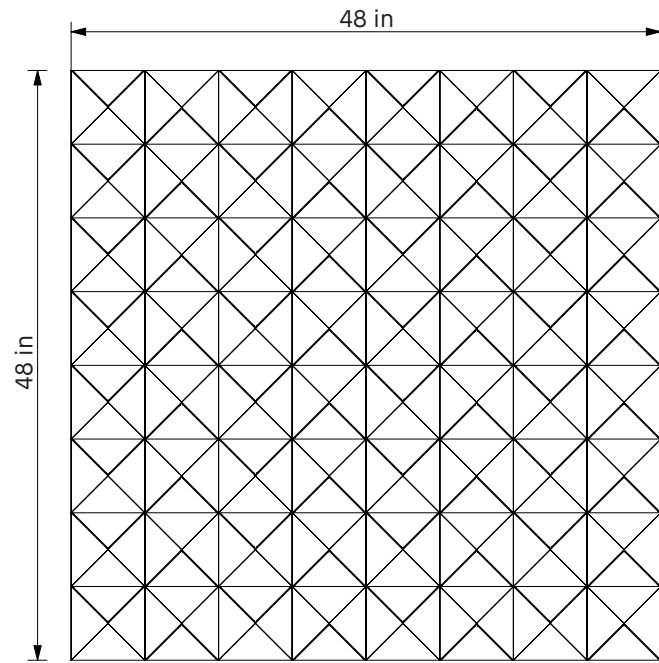

ELEVATION—ASSEMBLED PANEL

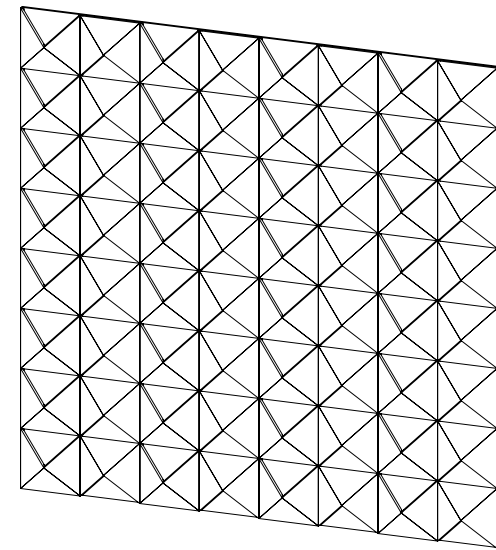

ISOMETRIC

Dimensional Folding  
(double layer)

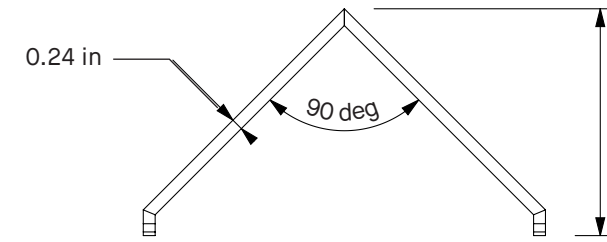

PART ELEVATION

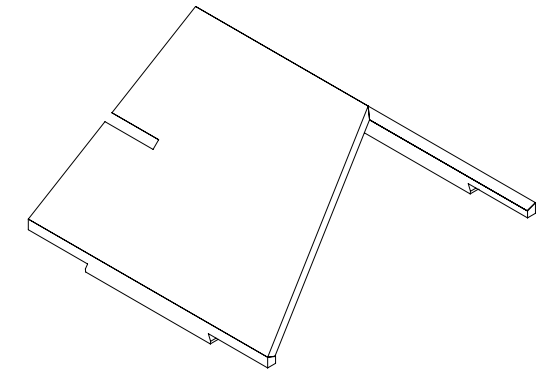

ISOMETRIC

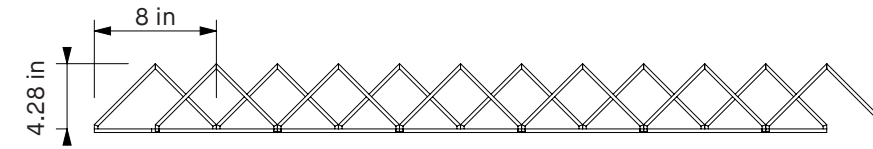

SECTION DETAIL

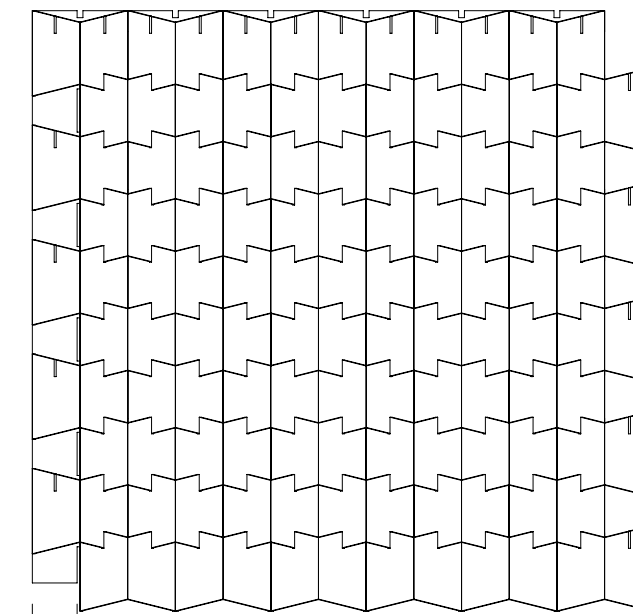

ELEVATION—ASSEMBLED PANEL

2, 22.5 deg cuts = 1, 45 deg V-cut  
Live hinge depth

2, 45 deg cuts = 1, 90 deg V-cut  
Live hinge depth

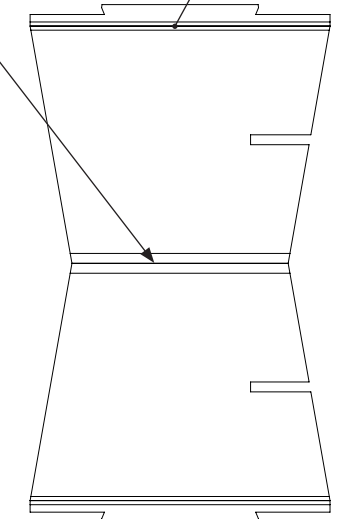

FLAT PATTERN

Basket

Dimensional Weaving  
(single layer)

Fog GATH 704

# Technique Dimensional: Woven

To create our woven *Basket* panel, **GATHER**® material is cut into 4.5"-wide strips that extend to cover the 4-foot width and 10-foot height of a panel. The strips are then interwoven to form a striking basketweave design that is secured at the ends. The layering and semi-open design help improve sound absorption, as does applying it over a **GATHER** "base layer" panel.



Basket

Dimensional Weaving  
(single woven)

Sienna GATH 701

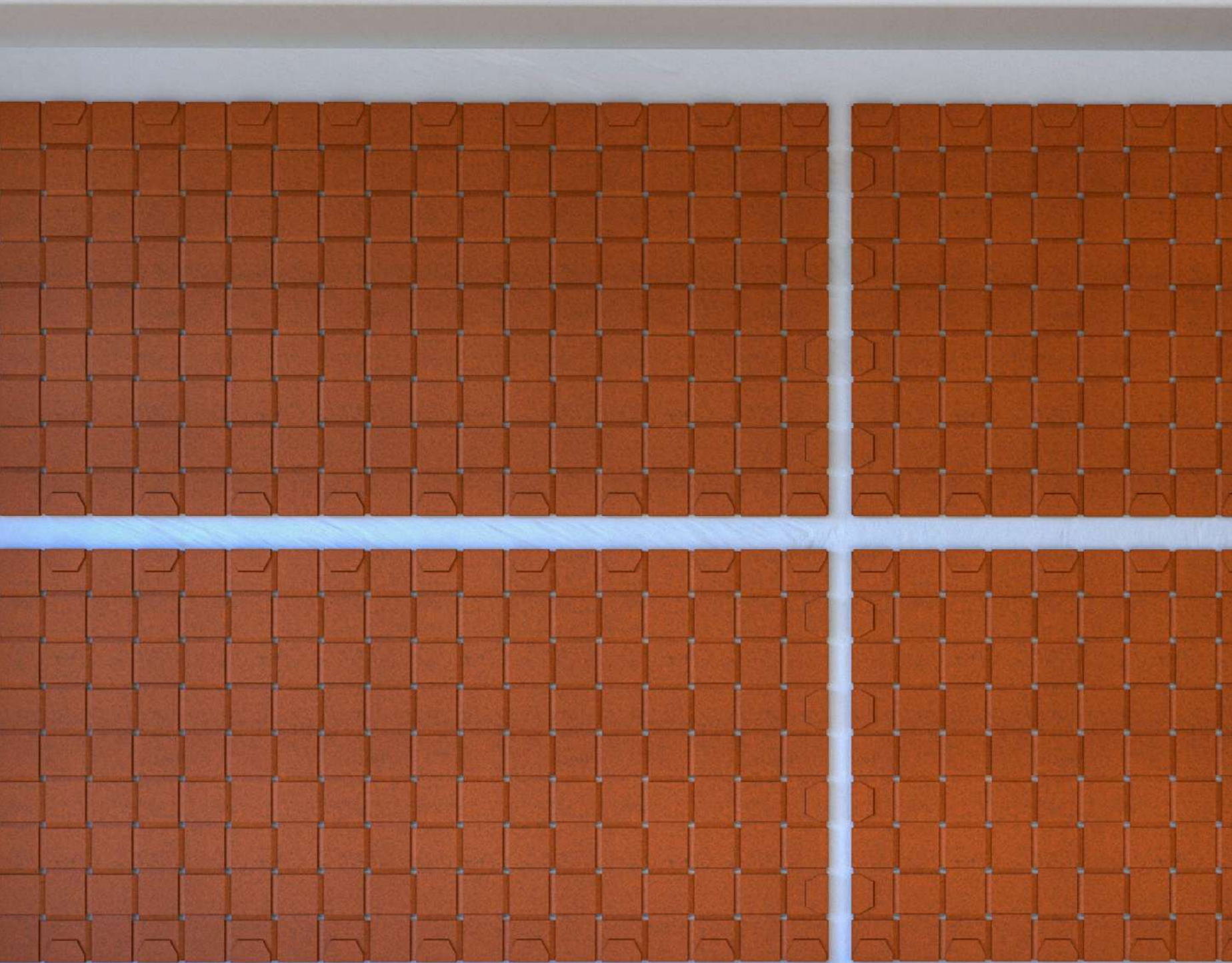

Basket

Dimensional Weaving  
(single layer)

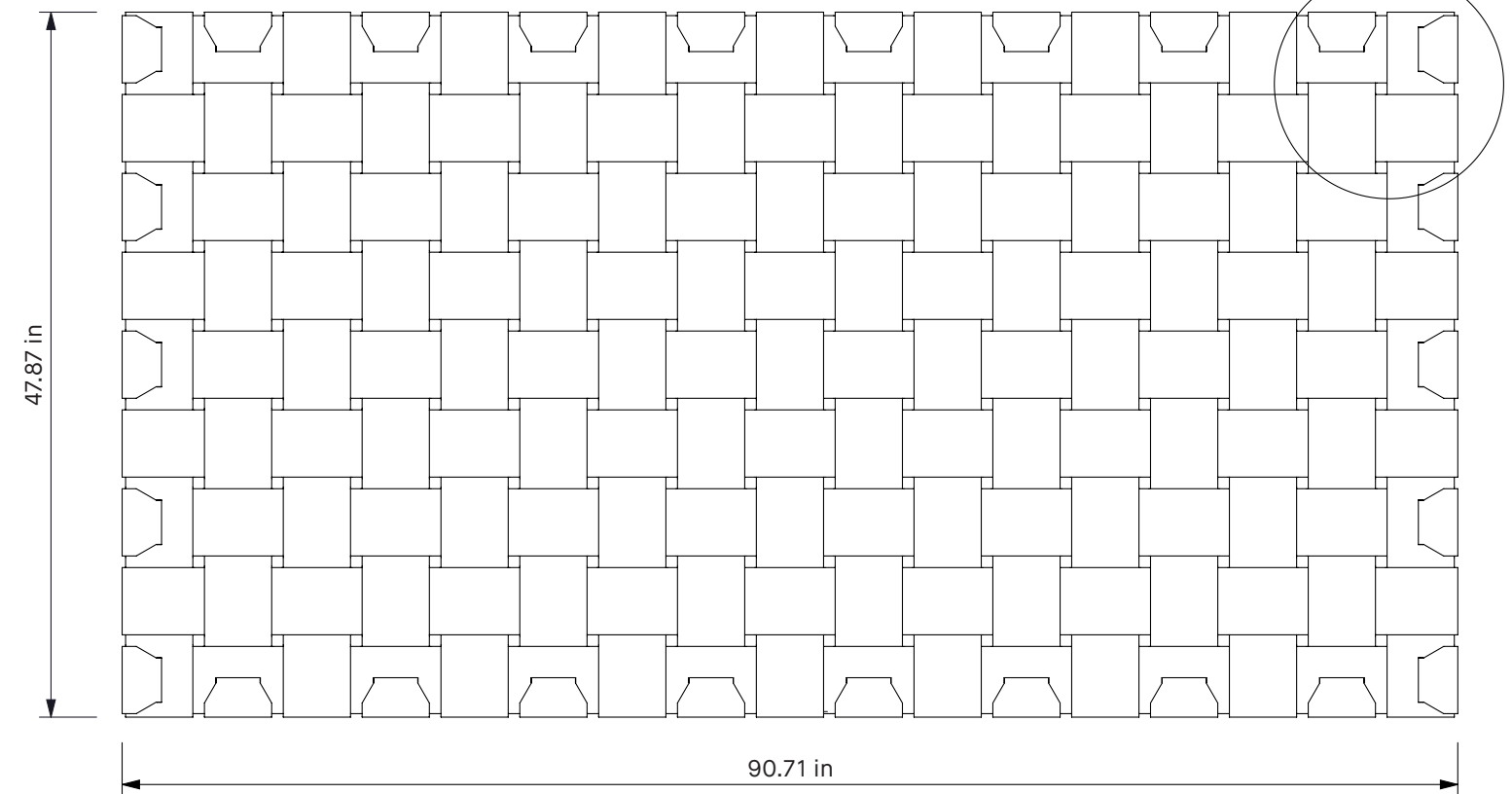
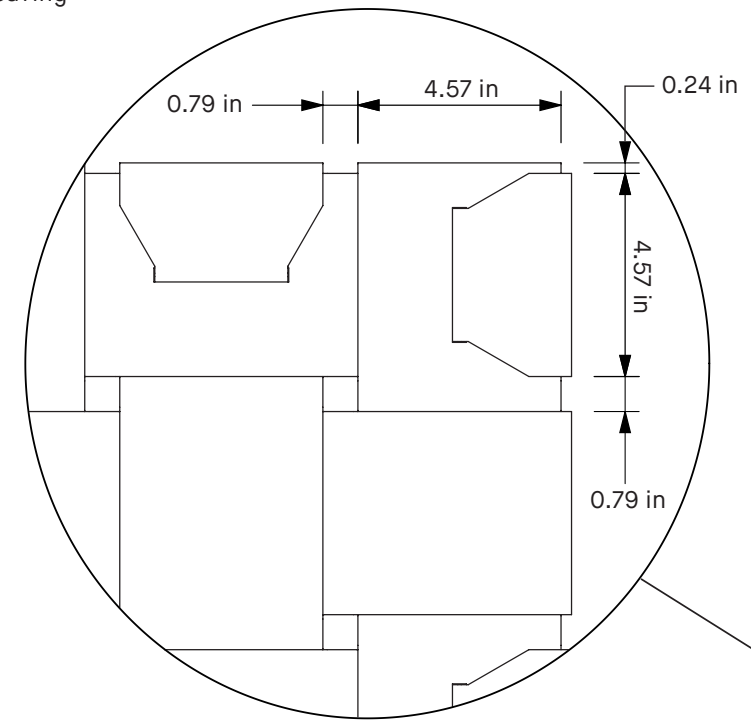

ELEVATION—ASSEMBLED PANEL

Pharaoh

Precision Cutouts  
(double layer)

Royal GATH 708  
Sienna GATH 701



# Acoustics

The art of designing an interior for good acoustics involves evaluating a number of factors because every surface, and the people occupying a space, contribute to the amount of noise absorbed and the sound quality. Controlling sound is an issue of absorption—where sound (air pressure) is not reflected back into the space—and diffusion—where the sound is scattered in many directions into the space, therefore reducing its strength. The goal of sound control is to decrease the speed and intensity of reverberation in a space, based on its function: be it a classroom, open office, lobby, or lounge. Sound control reduces the cacophony so we can truly hear one another.

The standard method for measuring sound absorption in a room is determining the Noise Reduction Coefficient (NRC) value. In some cases, a Sound Absorption Average (SAA) may also be used. The NRC and SAA values normally range from 0.0 to 1.0, with 0.0 indicating that a material absorbs 0% of the sound energy that reaches it per square foot of material, reflecting 100% back; and a 1.00 rating indicating that a material absorbs 100% of the sound energy, reflecting 0% back. These values can exceed 1.0 when thick specimens or specimens with large air spaces are tested. The NRC is the average of the sound absorption coefficients at four 1/3 octave frequencies (250, 500, 1000, and 2000 hertz)—the NRC value is rounded off to the nearest 0.05 increment. The SAA value is the average of the sound absorption coefficients at twelve 1/3 octave frequencies, ranging from 200 to 2500 hertz—the SAA value is rounded off to the nearest 0.01 increment.

For **GATHER® Acoustical**, the NRC values vary from 0.25 to 0.90 depending on the technique and method of application. The diagrams on the following pages illustrate noise reduction in different configurations of **GATHER** panels.

#### Reflection

There are many types of room reflection that affect the sound of your space. A reflection off of a nearby hard surface may be almost as loud as the original sound!

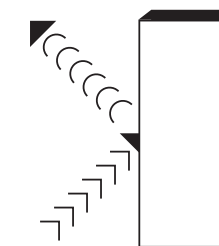

#### Absorption

Sound-absorbing foam or fiberglass is the most common way of controlling unwanted reflection.

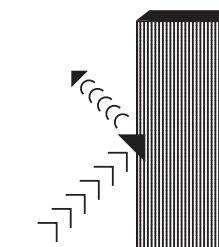

#### Diffusion

A diffusive surface doesn't directly reflect or absorb sound. Instead, it scatters it in many directions. Recent diffuser designs use irregular surfaces based on number theory sequences.

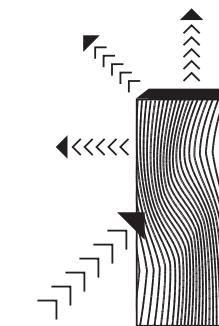

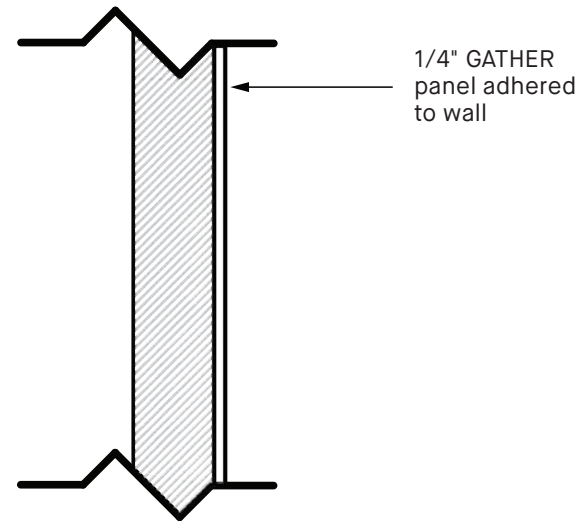

### NRC Rating = 0.25

**Design** Solid panel or *Bouquet, Brady, Cathode, Euclid, Gregori, Morgan, or Transporter*

**Technique** Single-layer V-Groove Engraving

**Installation** Adhered to new or existing wall

250 Hz	500 Hz	1000 Hz	2000 Hz	NRC
0.04	0.22	0.30	0.41	<b>0.25</b>

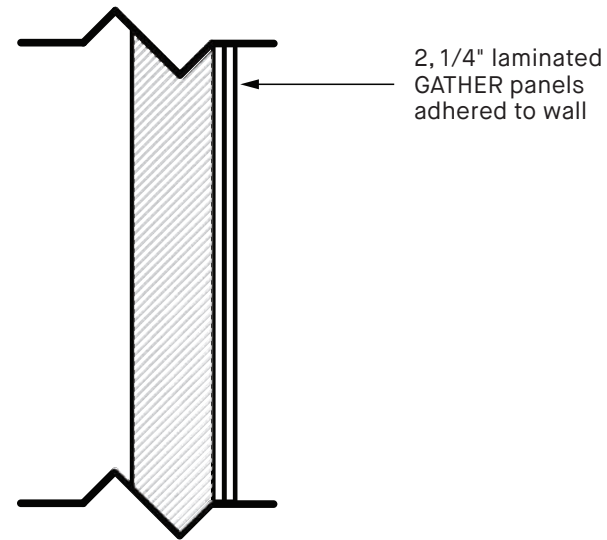

### NRC Rating = 0.45

**Design** *Club, Dottie, Ella, Escher, Gemini, Interpid, Pharaoh, or Semi*

**Technique** Double-layer Precision Cutouts or V-Groove Engraving

**Installation** Adhered to new or existing wall

250 Hz	500 Hz	1000 Hz	2000 Hz	NRC
0.02	0.23	0.58	0.88	<b>0.45</b>

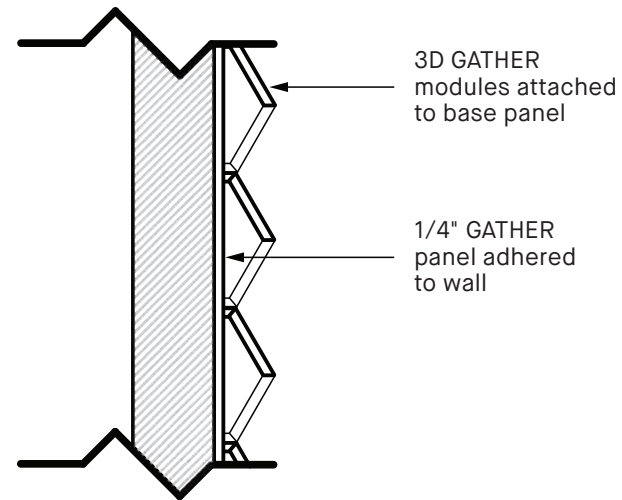

### NRC Rating = 0.55

**Design** *Shrine or Rafter*

**Technique** Dimensional: Folding

**Installation** Solid panel adhered to wall; Dimensional modules attached to base panel

250 Hz	500 Hz	1000 Hz	2000 Hz	NRC
0.08	0.39	0.78	0.90	<b>0.55</b>

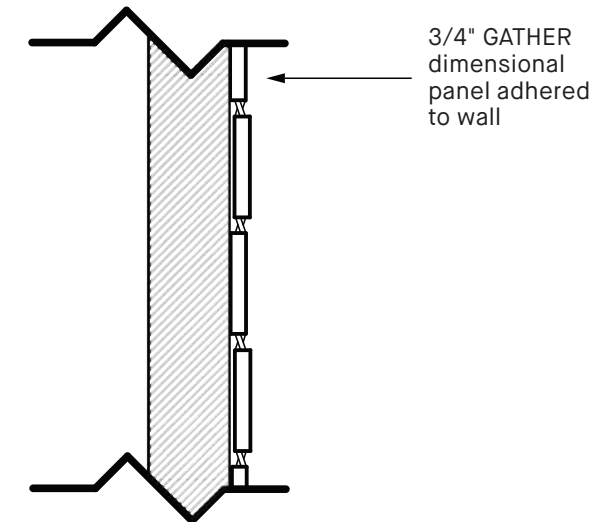

### NRC Rating = 0.50

**Design** *Basket*

**Technique** Dimensional: Weaving

**Installation** Adhered to new or existing wall

250 Hz	500 Hz	1000 Hz	2000 Hz	NRC
0.05	0.26	0.71	1.00	<b>0.50</b>

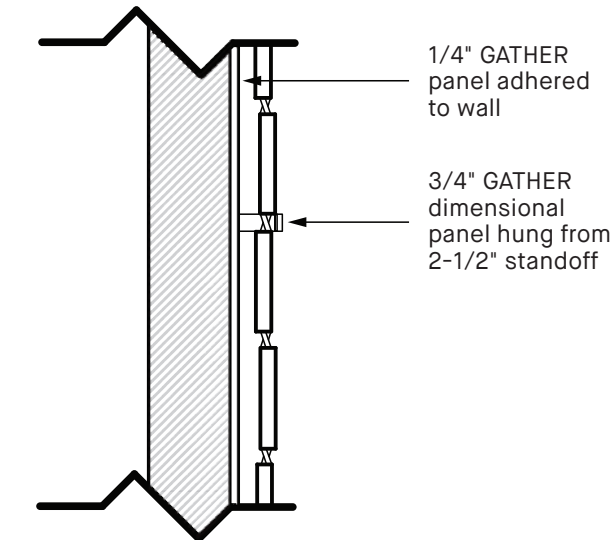

### NRC Rating = 0.90

**Design** Solid panel and *Basket*

**Technique** Dimensional: Weaving

**Installation** Solid panel adhered to wall; *Basket* hung from standoff hardware

250 Hz	500 Hz	1000 Hz	2000 Hz	NRC
0.47	1.07	1.10	1.02	<b>0.90</b>

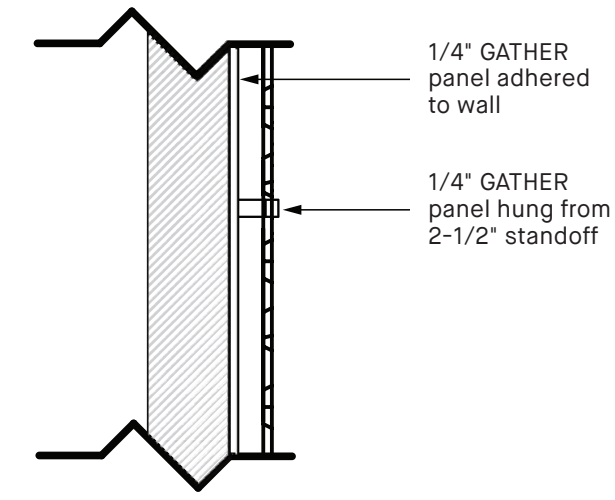

### NRC Rating = 0.80

**Design** Solid panel and *Dottie, Ella, or Pharaoh*

**Technique** Single-layer Precision Cutouts

**Installation** Solid panel adhered to wall; Single layer panel hung from standoff hardware

250 Hz	500 Hz	1000 Hz	2000 Hz	NRC
0.29	0.84	0.97	1.03	<b>0.80</b>



Semi

Precision Cutouts  
(double layer)

Fog GATH 704  
Putty GATH 705

# Installation and Hardware



Intrepid

Precision Cutouts  
(double layer)

Fog GATH 704  
Sunlight GATH 700

**GATHER® Acoustical** panels should be installed by a professional with experience installing wallcovering, wall and ceiling-hung panels, and other Division 10 specialty items.

The Installation and Maintenance Guidelines included with each order should be read carefully before proceeding. Different techniques may require special hardware, which should be provided by the installer based on recommendations from the architect or designer.

On the following pages is abbreviated information about different types of installations. Extensive instructions are available for you to download at [wolfgordon.com/gather](http://wolfgordon.com/gather).

**GATHER is Class A Rated for Fire Safety According to ASTM E84**

	Flame Spread	Smoke Developed
Adhered to Standard Drywall	15	155
Unadhered*	15	250

\*Appropriate for freestanding partitions



## Direct-To-Wall Installation

The most basic installation of **GATHER® Acoustical** panels is to adhere them to new or existing walls. Walls should be clean, dry, structurally sound, and prepared to a Level 4 finish (although a Level 5 is preferred). A good quality acrylic or latex wallcovering primer/sealer should then be applied

to the wall. Each acoustical panel is installed by applying a non-solvent-based adhesive to its back side before adhering it to the wall or substrate. The adhesive should be applied around the perimeter and across the central areas in a zig-zag or diagonal pattern, as shown in these diagrams.

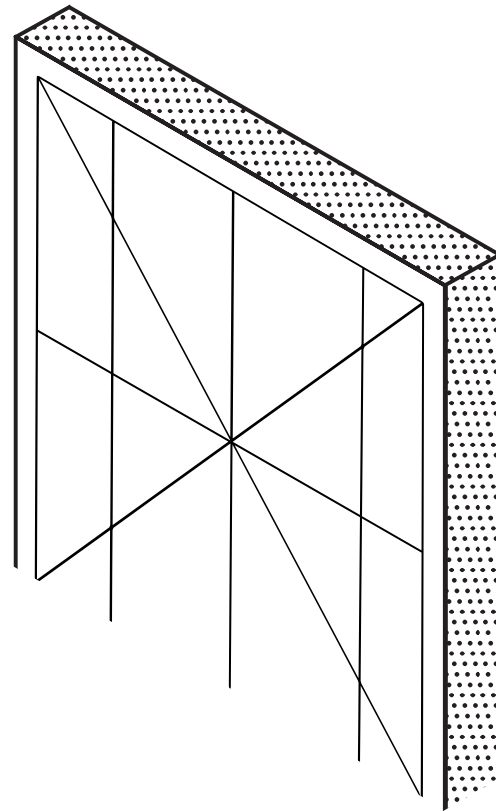
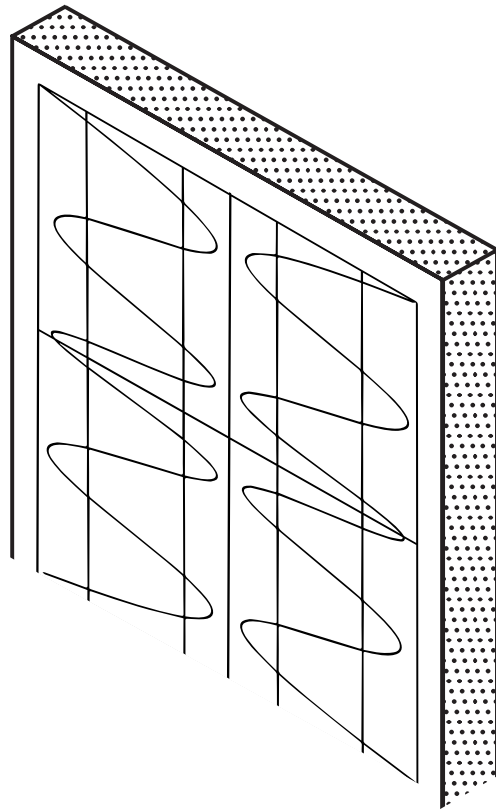

## Standoff Hardware

For installations where the **GATHER** panels are to be placed 1"–2.5" away from a new or existing wall, we recommend using our stainless steel

standoffs, available in 1", 1.75", and 2.5" lengths (purchased separately).

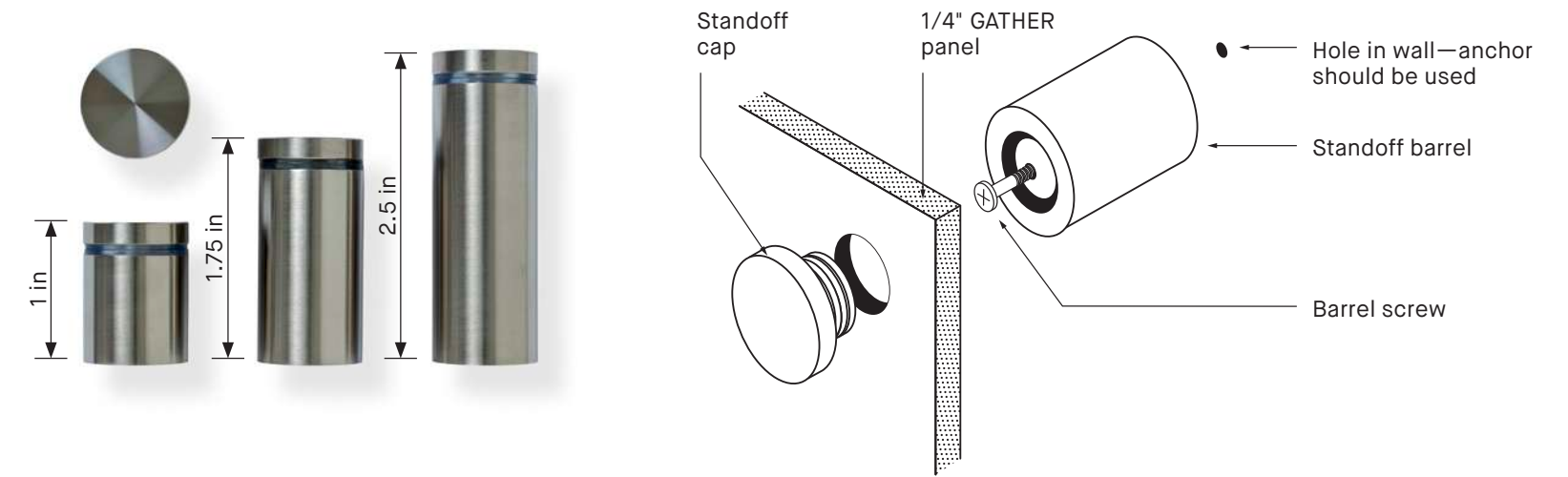

## Z-Clip Hardware

For installations where the **GATHER Acoustical** panels will need to be removable from a wall, we

recommend using our interlocking Z-Clips to hang the material (purchased separately).

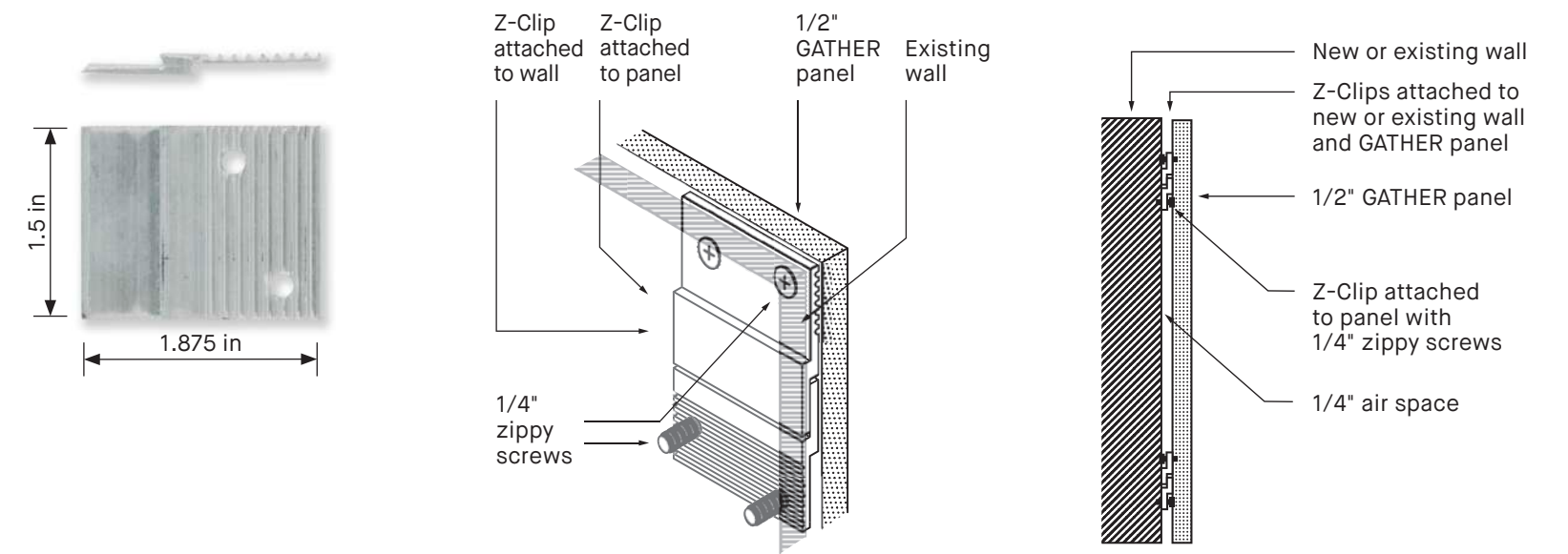



# Care and Maintenance

**GATHER® Acoustical** panels are composed of recycled polyester, a hydrophobic thermoplastic that is naturally stain- and water-resistant, which allows time for spills to be blotted with a damp cloth. Spills should be addressed quickly and with care.

All cleaning attempts should be done on an inconspicuous portion of a panel first, before applying to the stained or soiled area. First-step cleaning should be with a lint roller or dry brush, using light consistent strokes on the affected area. Lightly blot stains and spills with a slightly damp towel using a press-and-release action.



# Samples and Support

To order 4.5" square samples of **GATHER® Acoustical** in any of the 12 colors offered, please get in touch with your Account Executive or contact Wolf-Gordon customer service at 212 255 3300. 8" x 8" samples of the various designs are also available by emailing [wgcustomslab@wolfgordon.com](mailto:wgcustomslab@wolfgordon.com).

For any questions regarding our acoustical products, including customization and installation, contact our dedicated acoustical materials expert for assistance. Please call 212 255 3300 or email [wgcustomslab@wolfgordon.com](mailto:wgcustomslab@wolfgordon.com).

## Custom Capabilities

Custom panels of GATHER can be developed for our Digital Printing, V-Groove Engraving, and Precision Cutouts techniques for an additional fee. WG Customs Lab will collaborate with you to achieve your intended design. For Digital Printing, the maximum image size is 48" x 120"; larger images can be printed by using multiple panels. We can create custom patterns for V-Groove Engraving and Precision Cutouts based on your design concepts or inspiration images.

Fees for customization are based on feasibility analysis, conversion of the supplied concept, design and layout, and production of strike-offs. Development and rounds of approval can add 10–15 business days to a project's lead time.

# Where We Gather

There are many places where we gather together in small groups or larger communities. **GATHER® Acoustical** materials can introduce color and pattern to interiors while reducing echo, help define a space while controlling light and view, or provide privacy with a visual and tactile experience.

Some areas where you might consider **GATHER** include:

- collaborative office spaces, meeting rooms, and break areas;
- student lounges and casual seating spaces;
- entertainment venues, concert halls, and viewing rooms;
- hotel lobbies, bars, clubs, and dining areas;
- coffee houses and restaurants;
- library sections and bookstore reading areas;
- performance spaces;
- hospital and doctor's office waiting areas;
- condominium lobbies and recreational spaces.



# Remember...

A heightened sensibility to acoustical comfort has become an important factor when designing commercial spaces. With **GATHER®**, you can now control noise levels, reduce echoing, and improve sound quality while enhancing design and helping people feel more at ease in a space.

**GATHER Acoustical** offers:

- lightweight 4' x 10' acoustical panels in an array of heathered, saturated colors;
- a range of patterns that are cut out, engraved, folded, or woven in the color(s) of your choice;
- digitally printed imagery on a felt material that absorbs sound;
- the option to apply colorful, dimensional designs directly to walls or to suspend panels with hardware systems for use as screens or partitions;
- sustainable materials composed of recycled polyester that are free of harmful chemicals and compliant with green building standards;
- NRC ratings ranging from 0.25 to 0.90, depending on the configuration of the panel(s);
- easy cleaning and disinfecting with diluted bleach.

# About Wolf-Gordon

**Wolf-Gordon is an American design company dedicated to inspiring the creation of outstanding interiors. Founded in 1967 as a commercial wallcovering resource, our high performing product line has expanded to include PVC-free and natural wallcoverings, RAMPART® wall protection, upholstery textiles, Scuffmaster® paint, Wink® dry-erase surfaces, digitally printed materials and, now, GATHER Acoustical.**

We develop products that are provocative, inspiring and of our time. WG Design Studio regularly collaborates with leading international designers to bring fresh perspectives to our A&D clients. Concurrently, we focus on the aesthetic, technical, and sustainability issues that are essential to being a trusted supplier

to the commercial design industry. For signature, site-specific environments, our WG Customs Lab works closely with clients to design and produce their custom and digital print concepts for corporate offices, healthcare facilities, schools and universities, hotels, restaurants, and casinos.

**To learn more, visit [wolfgordon.com](http://wolfgordon.com) or call 212 255 3300.**