

# PRODUCT MANUAL

Model BU0036-BK01  
BU0036-WH01



**ATTENTION!** PLEASE READ THESE INSTRUCTIONS BEFORE USING THIS DEVICE

**PRODUCT MANUAL**

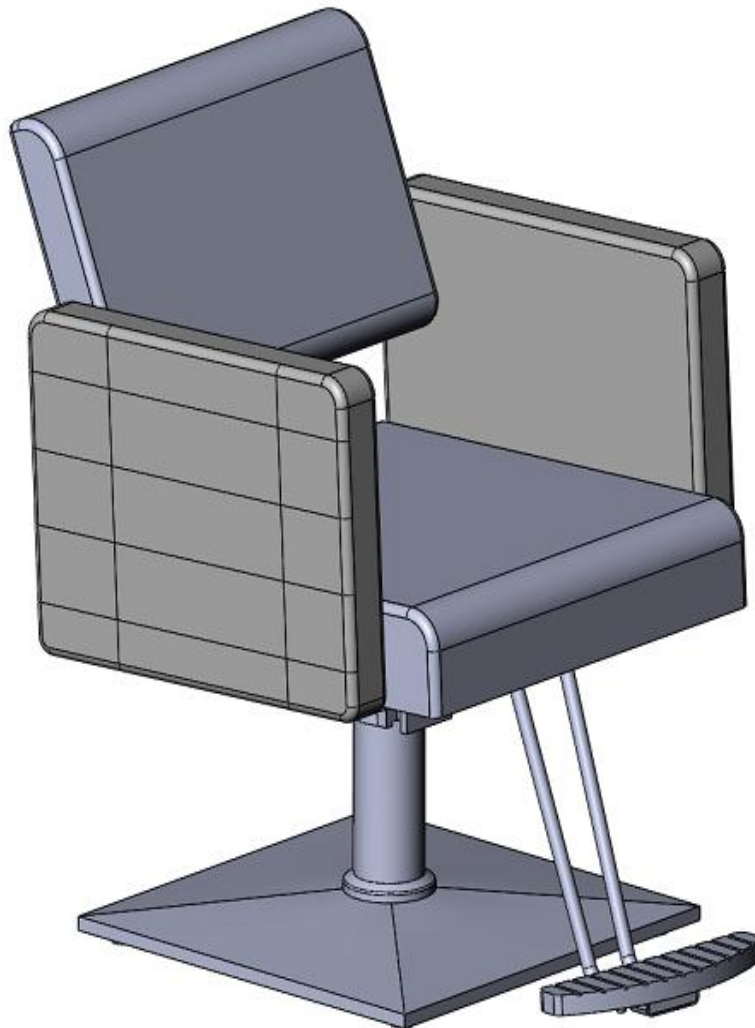

## NOTICE:

If your package is missing parts or you are having issues with assembly, please call us directly, Our customer service team will address any questions or concerns you may have.

Have this manual open and ready for reference.



## SAFETY

To reduce risk of injury when assembling & using the chair, follow these precautions:

- Read all of these instructions before assembling and using your salon chair.
- It is helpful to have 2 people assemble and turn the chair upright after assembling.
- Do not over-extend the chair(0~150kg), creating the risk of falls or tipping the chair, and its occupant over, resulting in injury

# PARTS & FEATURES

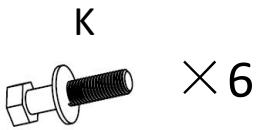
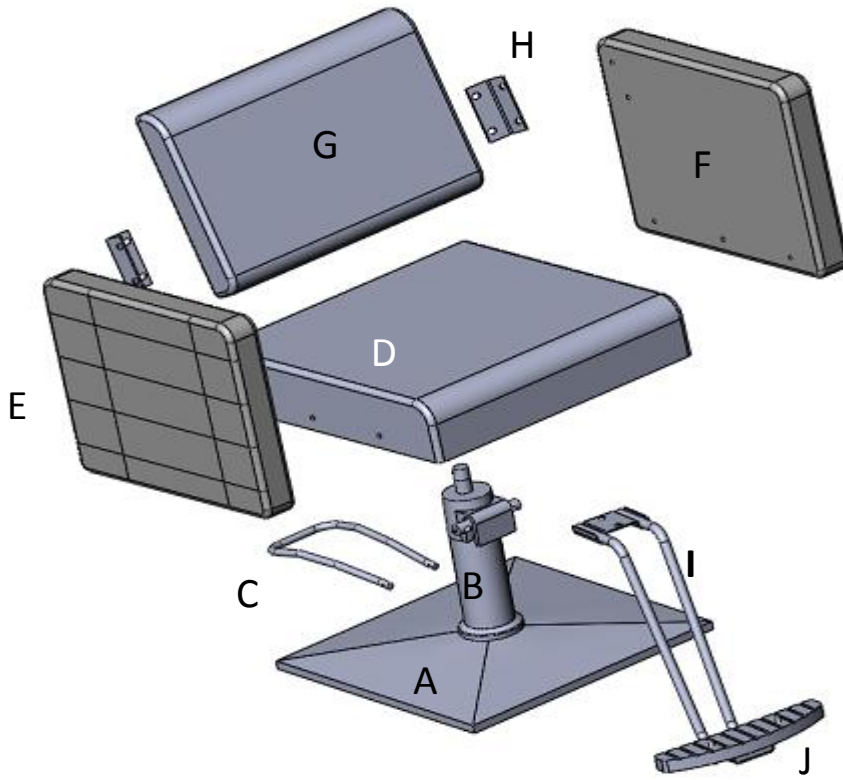

Part code	Part Name	Number	Part code	Part Name	Number
A	Base	1	B	Pump	1
C	Foot bar	1	D	Seat	1
E	Right handrest	1	F	Left handrest	1
G	Backrest	1	H	Backrest connector	2
I	Leg support	1	J	Foot rest	1
K	Screws	6			

# INSTALLATION INSTRUCTION

## First: Installation hydraulic pump to the base

Parts needed: Base + pump + foot bar

Step 1: Install pump to Base with 6 fixing bolts .

Step 2: Place assembled Base & Pump on floor. Use Allen Wrench to loosen the screws

in the crossbar. See photo besides.

Insert Foot Bar into the holes of the crossbar.

(May require slightly squeezing ends of Foot Bar towards each other, and some maneuvering for the bar ends to go into place.)

Step 3. Tighten the set screws to firmly hold the Foot Bar in place.

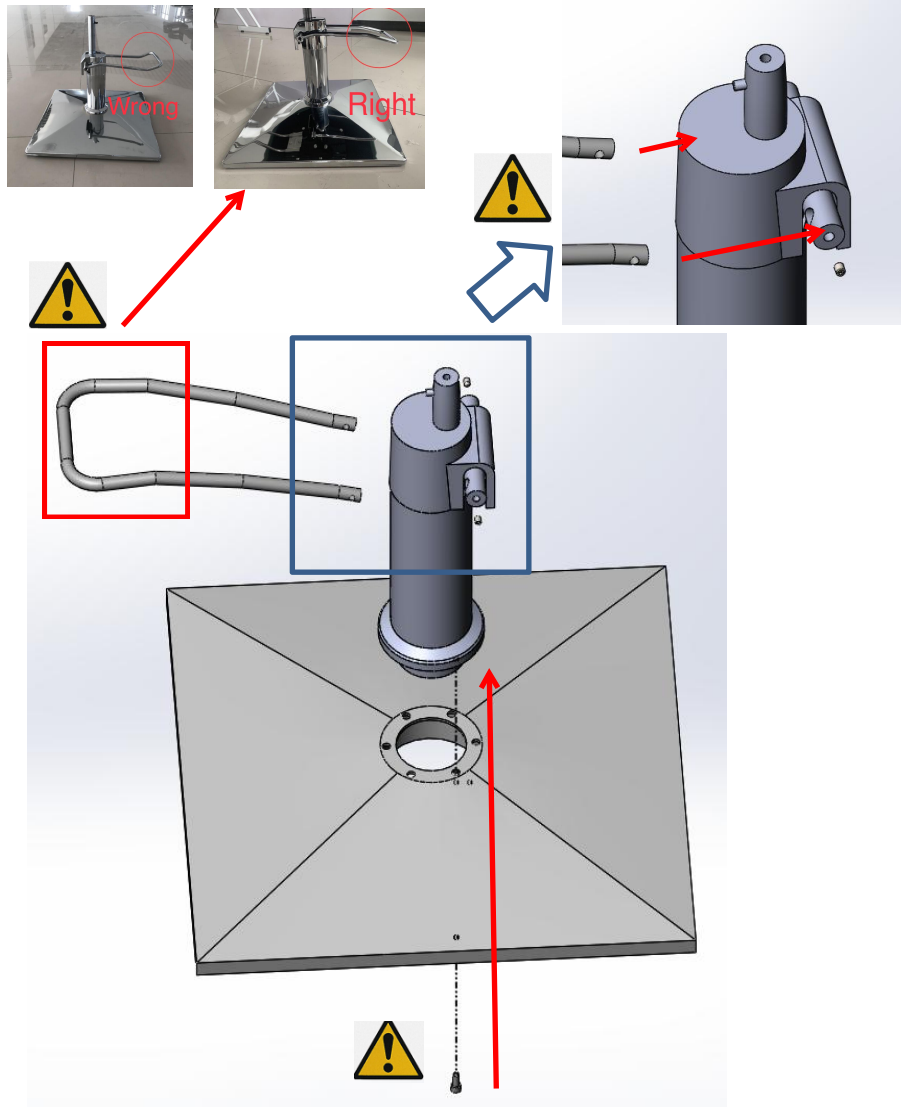

## Second : Install handrests to the seat

Parts needed: right handrest + left handrest + seat

Step 1 . Remove the 6 Screws which Pre-fixed on the handrests

Step 2 . Install handrests to the seat with the 6 screws.

Please follow up the diagram beside

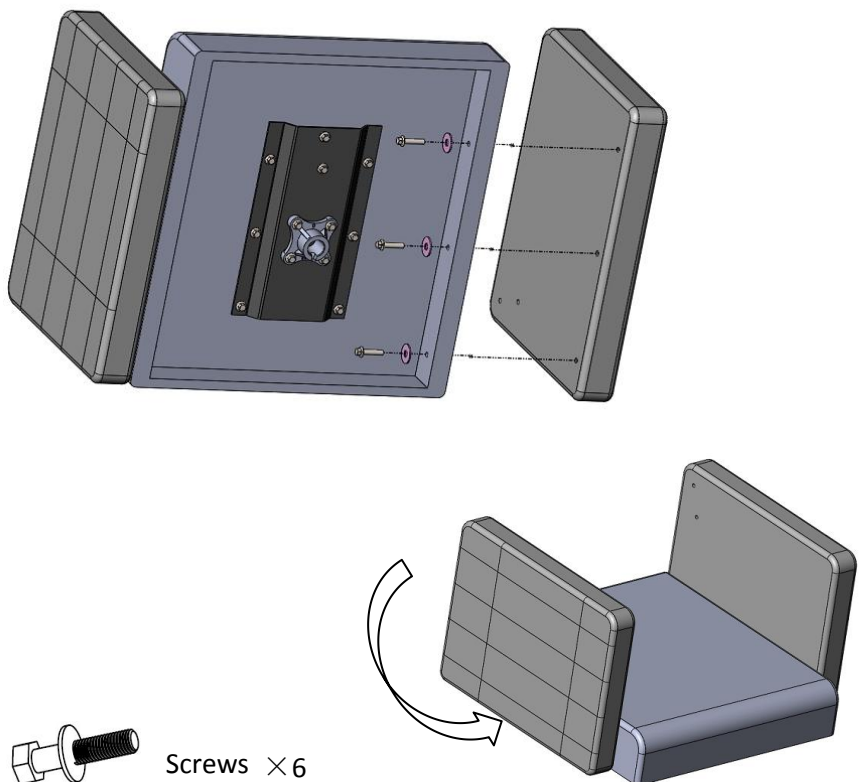

**Third : Install backrest connectors to the handrests**

Parts needed: 2 backrest connectors + installed seat & handrests

Step 1 : Remove 4 bolts which pre-fixed on the handrests.

Step 2 : Install 2 backrest connectors to the handrests with the 4 removed bolts.

Please follow up the diagram beside

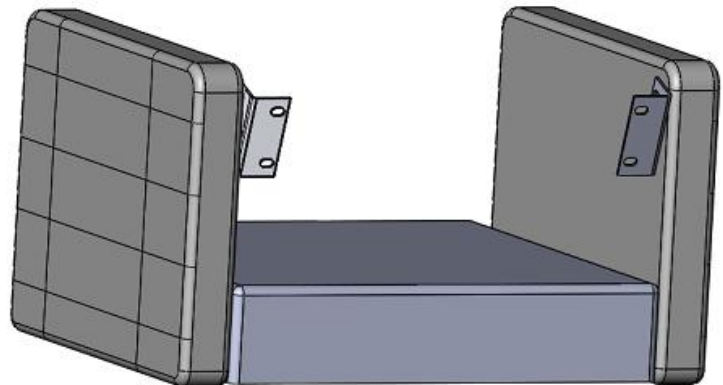
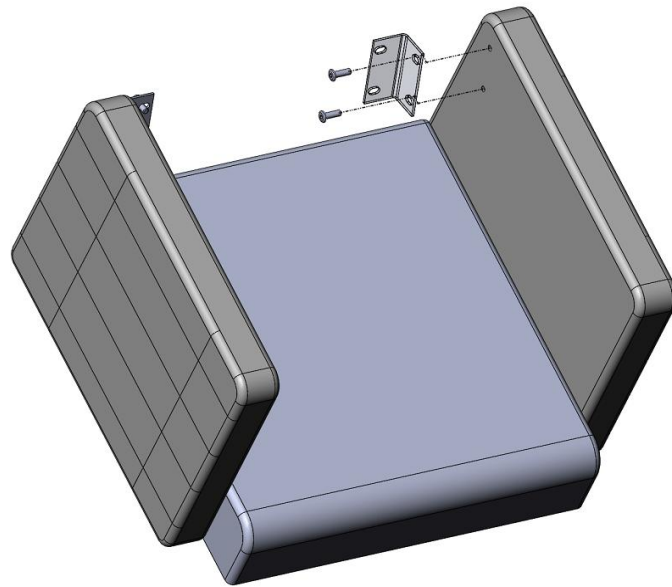

**Fourth : Install backrest to the seat**

Parts needed : Installed seat & backrest connectors + backrest

Step 1. Remove the 4 bolts which Pre-fixed on the backrest.

Step 2 . Install backrest on the backrest connectors by 4 removed bolts and tighten them.

Please follow up the diagram beside.

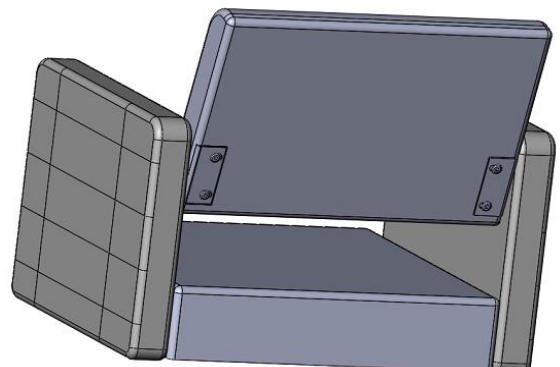
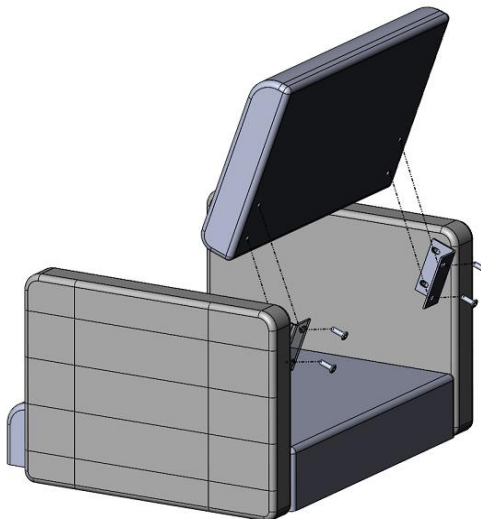

**Fifth : Install the installed seat to the installed base&pupm**

Parts needed : Installed seat + installed base&pupm

Step 1: Place the installed seat onto the hydraulic pump (please note the pin on the pump toward the gap of the pump joint)

Please follow up the diagram beside.

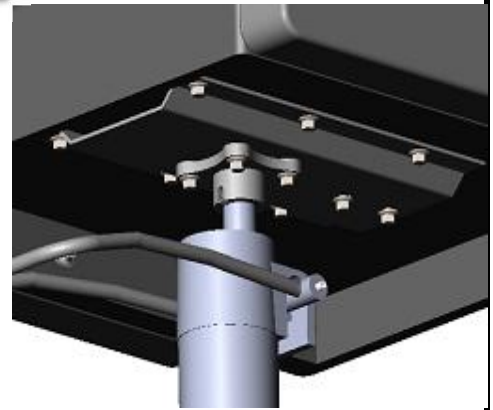
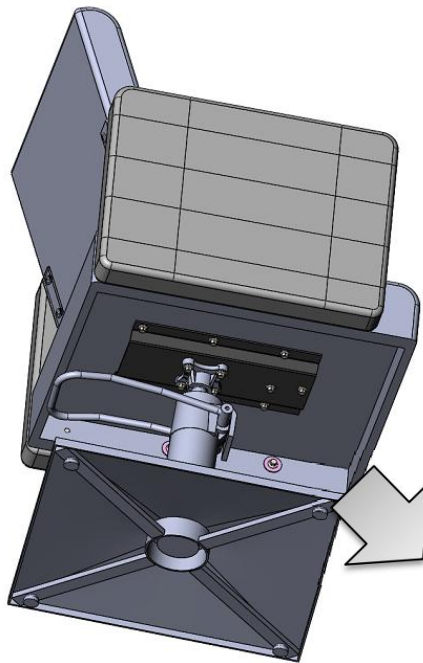

**Sixth : Install footrest to the leg support**

Parts Needed: Leg support + Footrest

Step 1: Remove 2 bolts which pre-fixed in the footrest

Step 2: Install the leg support to the footrest by 2 removed bolts and tighten them.

Please follow up the diagram beside.

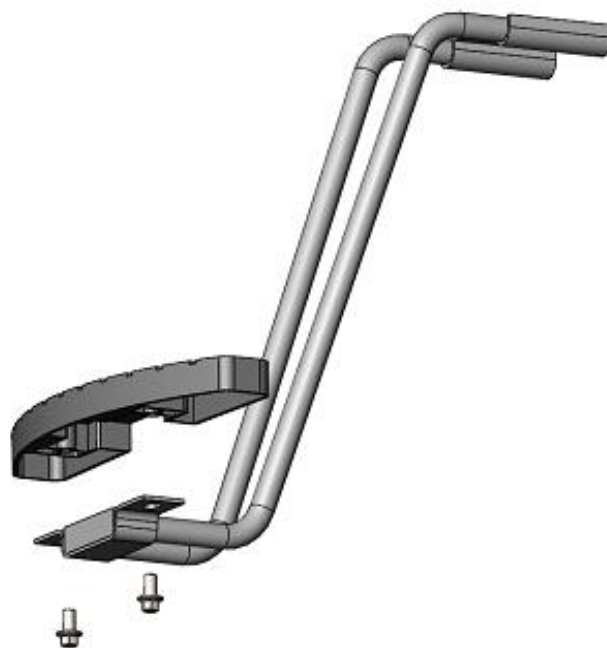



**Seventh : install the installed footrest on the seat**

1. Step 1 : Remove 2 bolts which pre-fixed in the seat

Step 2 : Install the installed footrest to the seat by 2 given bolts and tighten them .

Please follow up the diagram beside.

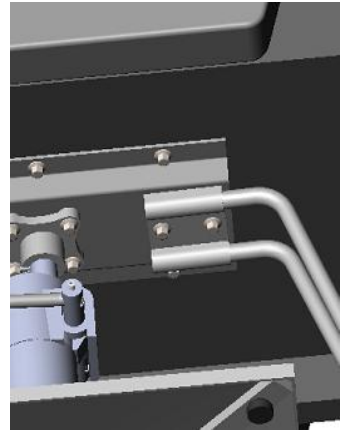
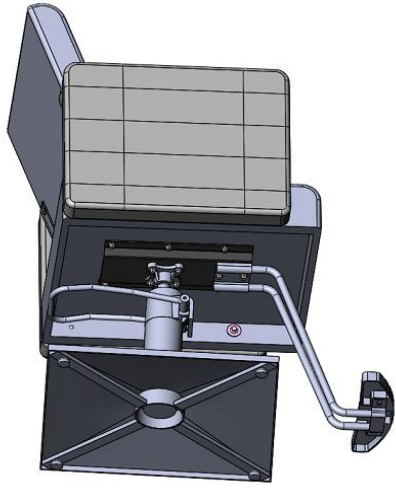

**OPERATING THE CHAIR**

• Step down on the Foot Bar repeatedly to raise the chair to the desired height.

• Step down and hold the Foot Bar to allow chair to lower.

• Hold the Foot Bar up to keep the chair still .

• Do not over-extend the chair, creating the risk of falls or tipping the chair and its occupant over, resulting in injury

