



Application

- Can be used to transfer clean water or other liquids similar to water in physical and chemical properties
- Suitable for industrial use and urban water supply, domestic water supply, high rise buildings, long distance water transfer and related auxiliary equipment etc.

Pump

- Cast iron pump body and support under special anti-rust treatment
- AISI 304 shaft
- Max. liquid temperature: +40°C
- Max. suction: +8 m
- Self-priming

Motor

- C&U bearing
- Motor with copper winding
- Built-in thermal protector for single phase motor
- Insulation class: F
- Protection class: IPX4
- Max. ambient Temperature: +40°C

Identification Codes

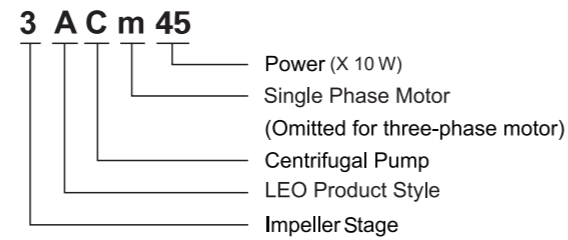

Technical Data

MODEL		POWER		Q (m³/h)																									
Single Phase	Three Phase	kW	HP	0	0.3	0.6	0.9	1.2	1.5	1.8	2.4	3.0	3.6	4.2	4.8	5.4	Q (l/min)												
			H (m)																										
			0	5	10	15	20	25	30	40	50	60	70	80	90	0	10	20	30	40	50	60	70	80	90				
3ACm45	—	0.45	0.6	35	33.5	32.5	31.5	30	28.5	26.5	23	18.5	14	9	-	-	35	33.5	32.5	31.5	30	28.5	26.5	23	18.5	14	9	-	-
4ACm60	—	0.6	0.85	46.5	45	44	42.5	40.5	38.5	36	30	24	17	10	-	-	46.5	45	44	42.5	40.5	38.5	36	30	24	17	10	-	-
3ACm60	—	0.6	0.85	36	35.5	35	34.5	34	33.5	32.5	30.5	28.5	26	23	19	13.5	36	35.5	35	34.5	34	33.5	32.5	30.5	28.5	26	23	19	13.5
4ACm75	4AC75	0.75	1	46.5	45	44	43	42	41	40	38	35.5	32.5	28	23	17	46.5	45	44	43	42	41	40	38	35.5	32.5	28	23	17

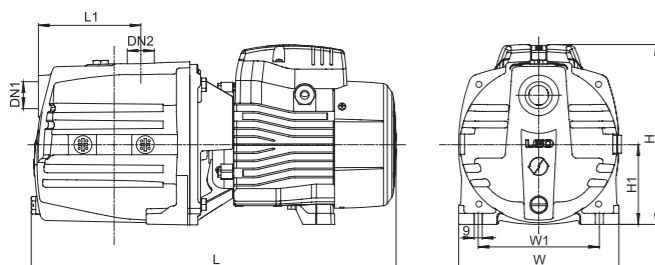

Dimension

Model	DN1	DN2	L (mm)	W (mm)	H (mm)	L _i (mm)	W _i (mm)	H _i (mm)
3ACm45	1"	1"	368	180	183	90	136	90
4ACm60			405	180	183	115	136	90
3ACm60			485	180	202	90	136	90
4ACm75			510	180	202	115	136	90

Hydraulic Performance Curves

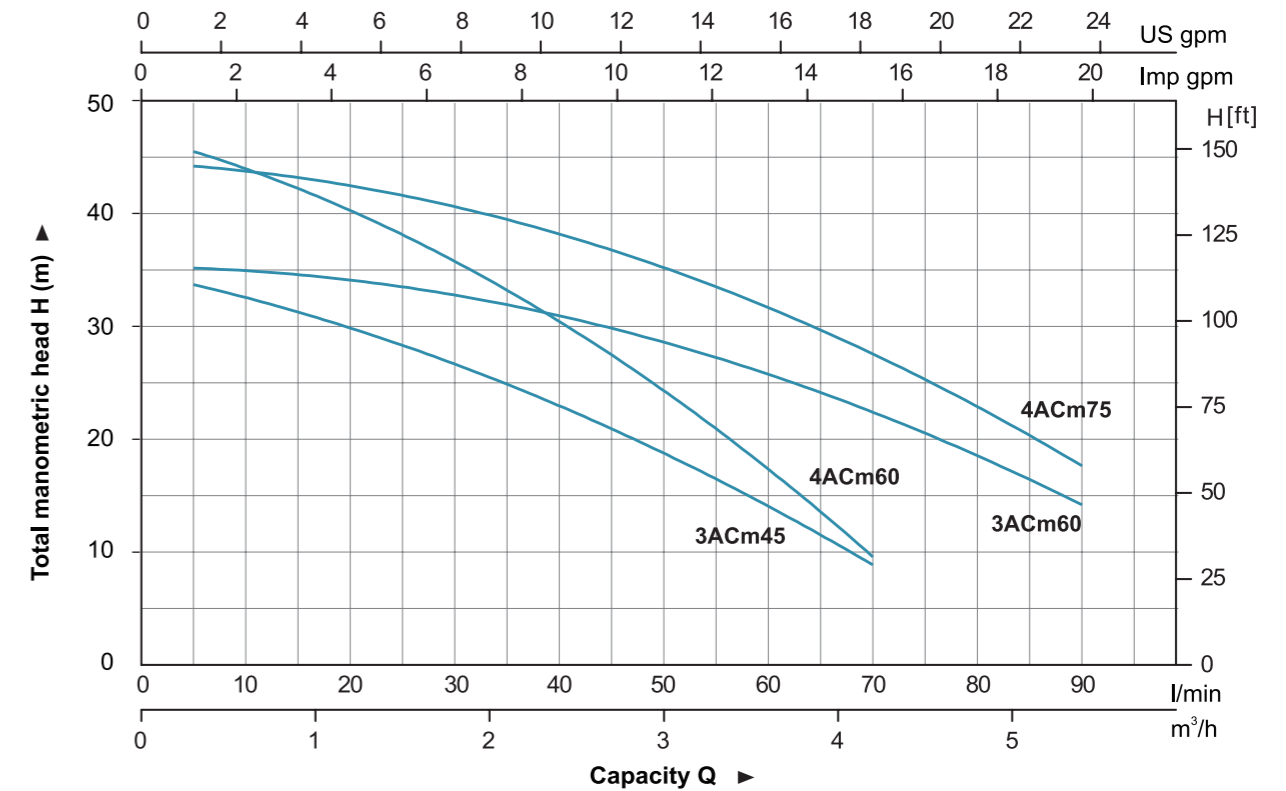

Materials Table

No.	Part	Material
1	Pump body	HT200
2	Pump cover	PPO
3	Return valve	PPO
4	Diffuser 1	PPO
5	Impeller	PPO
6	Diffuser 2	PPO
7	Diffuser holder	PPO
8	Support frame	PPO
9	Mechanical seal	Carbon/Ceramic
10	Bracket cover	HT200
11	Oil seal	
12	Support	ZL102
13	Bearing	
14	Rotor	
15	Stator	
16	Terminal box	ABS
17	Capacitor	
18	Rear cover	ZL102
19	Fan	PP
20	Fan cover	PP

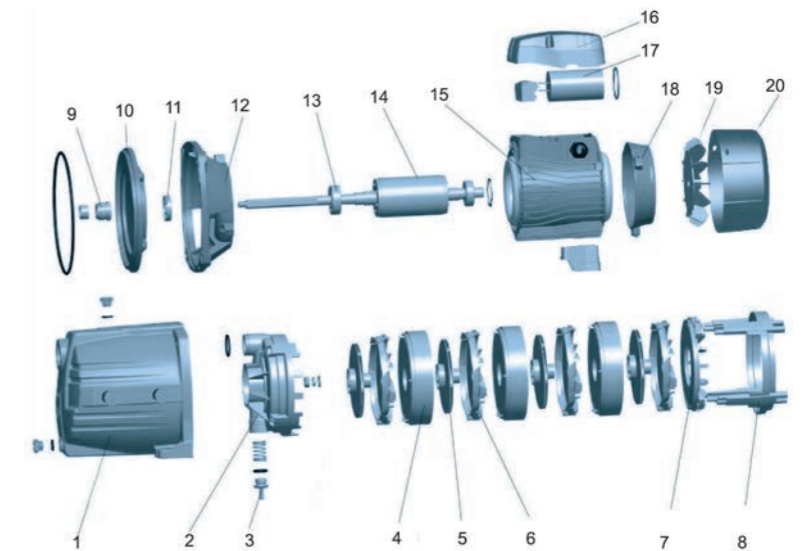

Package Information

Model	GW (Kgs)	L (mm)	W (mm)	H (mm)	Quantity (PCS/20 TEU)
3ACm45	13.2	410	200	210	1515
4ACm60	16	460	200	230	1233
3ACm60	15.3	435	200	230	1305
4ACm75	17	460	200	230	1176

