

# Generation 2 Man-Machine Interface (MMI) Controllers

## Multi-Functional Control for Intuitive Operation

- Three Mechanical Form Factors:
  - Rotary Encoder with Optional Pushbutton
  - Digital Joystick Encoder with Pushbutton
  - Proportional Joystick with Optional Pushbutton
- Modern Flush Styling
- No-tool Snap-in Front Mounting
- Designed for ISO 13849 Safety Rated Vehicles
- Self-Diagnostics Include:
  - Supply Voltage Monitoring
  - Indicator Operation Verification
  - Button Short Detection
- J1939
- Designed for 12/24 Volt Systems
- Dimmable LED Indicators and Legends
- Low Current Sleep Mode (<1.5 mA Current Draw; Wake Up on Key Press/CAN Message)
- Same Field-tested Reliability as our Original MMI Controllers - Over 500,000 in Operation
- Software Backwards Compatible with our Original VDC
- Customizable Legends, Indicator Colors, Backlight Colors, Knob Colors



Rotary Encoder with 16  
Position Continuous Rotation



Digital Joystick with 20  
Position Continuous Rotation



Proportional Joystick with  
Momentary Rotation

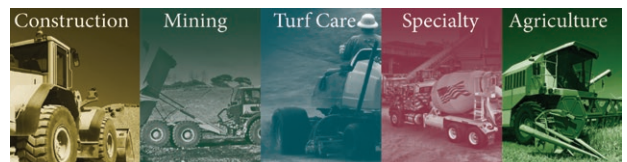

**DIMENSIONS** in mm [inch]

**3JX0X5-G2-100X**  
ROTARY ENCODER VERSION

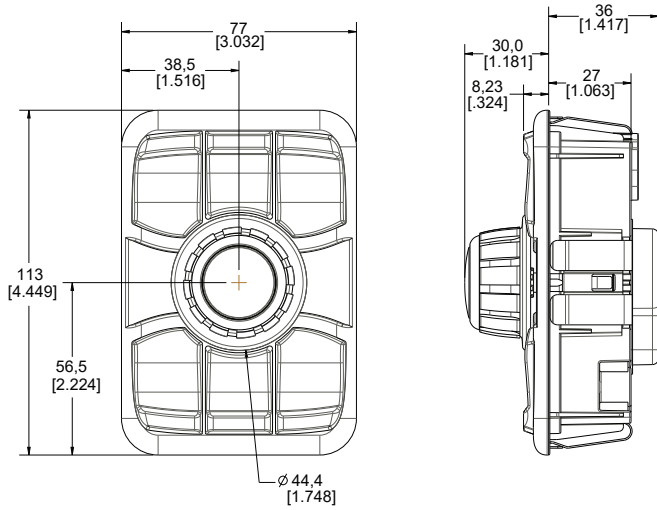

**3JX115-G2-100X**  
DIGITAL JOYSTICK VERSION

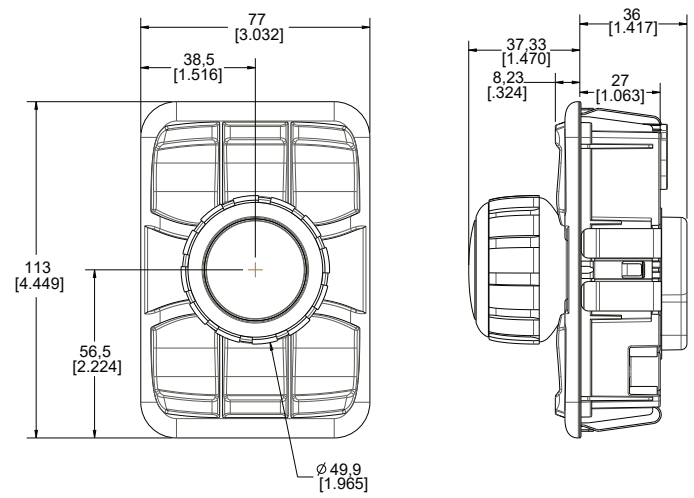

**3JX2X5-G2-100X / 3JX305-G2-100X**  
PROPORTIONAL JOYSTICK / DUAL PROPORTIONAL OUTPUT VERSION

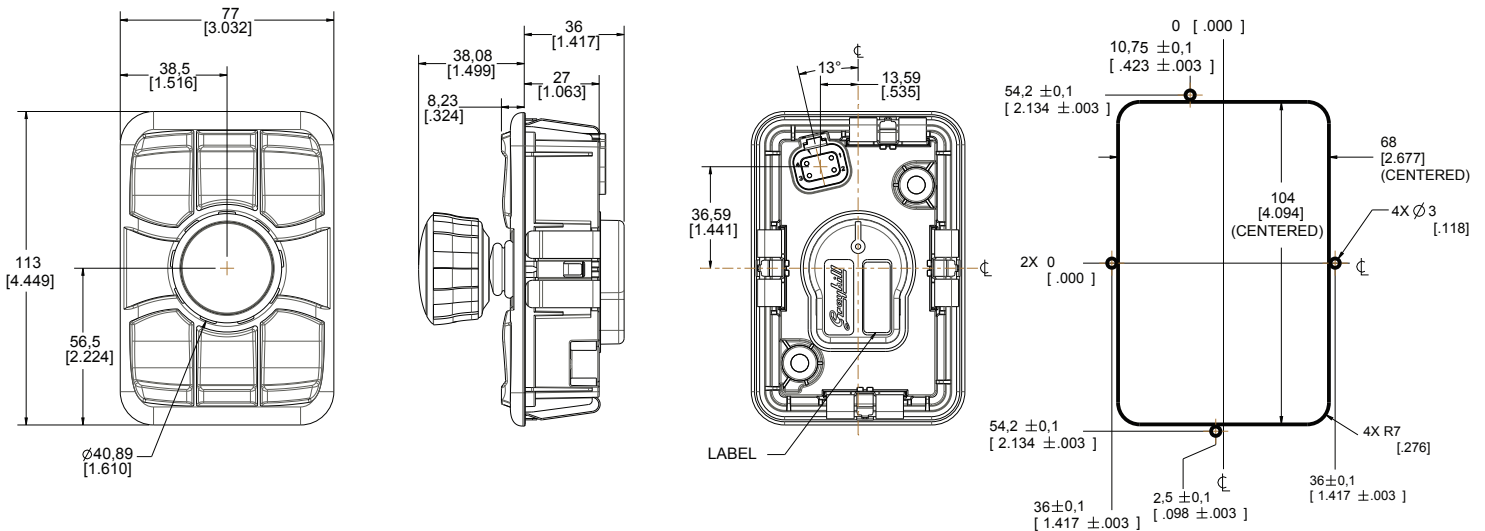

**Panel Cutout**  
**RECOMMENDED PANEL THICKNESS: 2,5 [0,098]  $\pm$  1,0 [0,039]**

CONNECTOR: MATES WITH DEUTSCH #DT06 - 4S WITH W4S WEDGE LOCK.

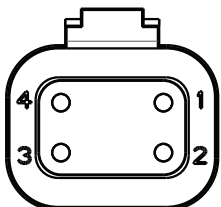

PIN	SIGNAL
1	POWER
2	GROUND
3	CAN_H
4	CAN_L

## STANDARD KEYPAD SYMBOL OPTIONS

-0: BLANK

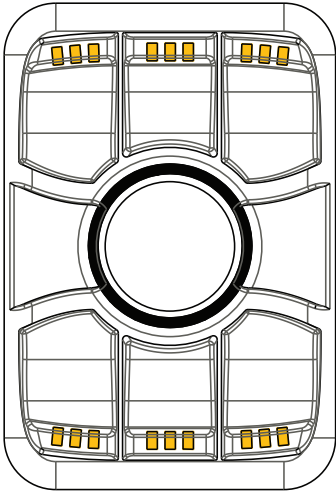

-1: ISO SYMBOLS

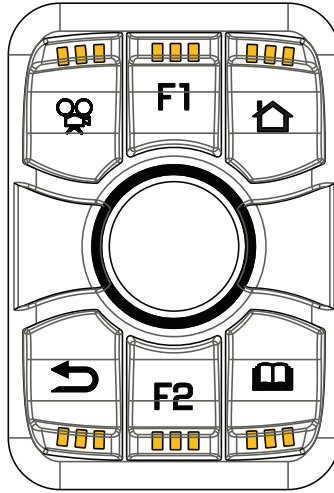

-2: GENERIC TARGETS

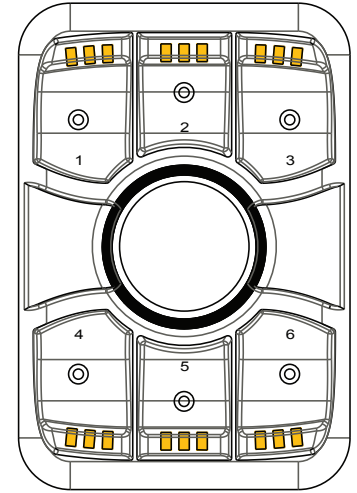

## STANDARD KEYPAD SYMBOL

### KNOBBS

Contact us about optional knob colors!



### LEDS

Contact us for optional LED colors

#### Indicator colors:

- Amber (Standard)
- Blue
- Green
- Red
- White
- Yellow

#### Backlight colors:

- Green (Standard)
- White (Standard)
- Amber
- Blue
- Pure Green
- Red
- Yellow

### LEGENDS

Contact us for Custom Legends

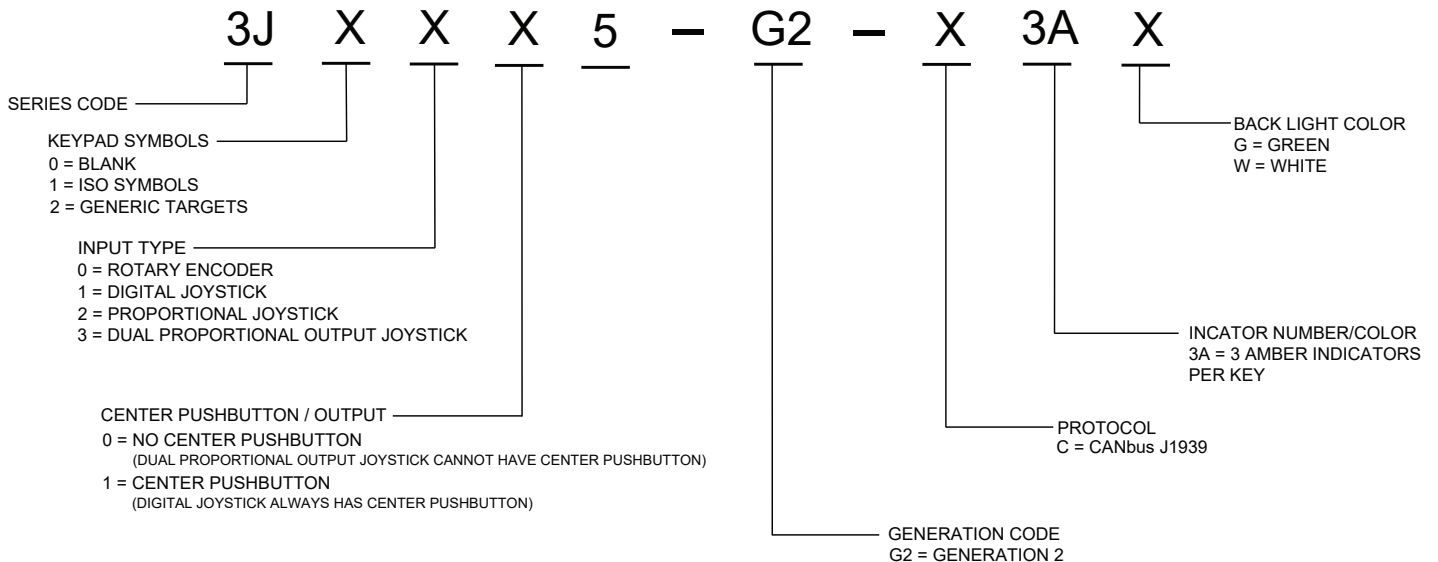
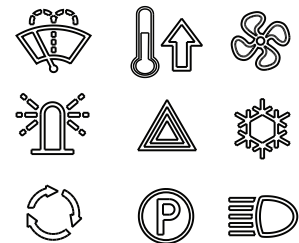

## ELECTRICAL SPECIFICATIONS

Maximum Load	ISO 16750-4 5.1	Low Temp = -40C, High Temp = +85C Duration: 4 hours at Low Temp, 11 hours at High Temp Maximum load applied
Over-voltage	ISO 16750-2 4.3.2	High Voltage: 36V, Duration: 60 min Tmax - 20 °C
Superimposed alternating voltage	ISO 16750-2 4.4	Severity 2 and 3 Ri = 50mΩ Frequency Range: 50Hz to 25kHz Sweep Duration: 120s Number of sweeps: 5 (continuously)
Slow decrease and increase of supply voltage	ISO 16750-2 4.5	
Momentary drop in supply voltage	ISO 16750-2 4.6.1	Class B No Reset
Reset behavior at voltage drop	ISO 16750-2 4.6.2	Class C
Starting Profile	IISO 16750-2 Sec. 4.6.3 Formerly known as pulse 4	12V, Level II Class B and Level IV Class A 24V, Level II Class A and Level III Class A
Load Dump	ISO16750-2 sec 4.6.4.2.2 Test A Formerly known as ISO7637-2 pulse 5	12V: Us = 101V, Ri=0.5Ω, td=400ms 24V: Us = 202V, Ri=8.0Ω, td=350ms
Reverse Polarity	ISO 16750-2 4.7.2.3	Voltage: -28V, Duration: 60s
Open Circuit tests	ISO 16750-2 4.9.1.2	Relay and signal outputs to be connected to load
Short-circuit Protection	ISO 16750-2 4.10.2 Signal Circuits	Connect all signal inputs and outputs to Vmax and GND for 60s. One circuit tested at a time.
Short-circuit Protection	ISO 16750-2 4.10.3 for load circuits	ISO 8820 operating time rating +10% Minimum Class C
Parallel inductive load	ISO7637-2 Pulse 1	Us = -600V
Wire Harness Inductance	ISO 7637-2 Pulse 2a	Wire Harness Inductance
Switching Spikes	ISO 7637-2 Pulse 3a	Pulse 3a: Us = -300V Pulse 3b: Us = +300V
Fast transients mutual coupling	ISO 7637-2 Pulse 3b	Pulse a: 24V class IV Us = -80 Pulse b: 24V class IV Us = +80
Slow transients mutual coupling	ISO7637-3 4.3.2	DCC Slow + = +30 DCC Slow - = -30 ICC slow + = +6 ICC slow - = -6

## PHYSICAL SPECIFICATIONS

Vibration, Random	ISO 16750-3 4.1.2.7	Commercial vehicle, Sprung Masses
Vibration, Sinusoidal (Resonant Response between 50-80 Hz)	MIL-STD-202G, Method 204D, Test Condition C	Logarithmic Sweep from 10 Hz - 2000 Hz - 10 Hz over a period of 20 minutes Duration: 4 hours duration (12 cycles) in each of 3 orthogonal axes. Maximum displacement for 10Hz - 55Hz: 0.06". Constant acceleration for 55Hz - 2000 Hz: 10G.
Shock/Crash Safety	ISO 16750-3 4.2.2	10 pulses per direction
Drop	ISO 16750-3 4.3	Height: 400 mm Repeat for all practical edges and faces
Mechanical Life	Internal Testing Procedure	Keypad 1M Cycles Center Pushbutton 1M Cycles Rotary Encoder 1M Cycles Optical Joystick 500K Cycles Proportional Joystick 1M Cycles Momentary-turn Encoder 1M Cycles

## ENVIRONMENTAL SPECIFICATIONS

Operating temperature	ISO 16750-4 5.1.1.2 ISO 16750-4 5.1.2.2	Low temperature -40°C for 24hrs High temperature +85°C for 96hrs
Storage Temperature	ISO 16750-4 5.1.1.1 ISO 16750-4 5.1.2.1	Low temperature -55°C High temperature +105°C
Thermal Shock (Ice Water Shock Test)	ISO 16750-4 5.4.3	High temperature +85 °C
Altitude (Barometric Pressure)	IEC60068-2-13 Method 105C Test Condition B	Sea level to 15240m (101.3 kPa to 11.6 kPa), Exposure Time: 2 hour
Solar Radiation	ISO 4892-2 Method B	1000 hours
Ingress Protection	IEC 60529 / ISO 20653 8.3.3 - IP6K7	Dust - Talcum powder Liquid - 1m submersion for 30 minutes
Wash Down	SAE J1211 Section 4.4 >>ISO 60529 / ISO20653	375 kPa and 8.3 L/min for 10 minutes @ 15°C
Humidity	ISO 16750-4 5.7 (Damp Heat) ISO 16750-4 5.6.2.2 (Humidity Cycling)	96% Humidity at +35°C, Duration: 240 hours
Salt Fog	ISO 16750-4 5.5.1	5% aqueous solution of NaCl @ 35°C and a pH between 6.5 and 7.2 for 48 hours
Thermal Cycling	Custom Test (Extended Duration Temperature and Humidity Cycling)	Low temperature: -40° High Temperature: +85 °C
Chemical Resistance	ISO 16750-5	(All agents on Table 1 except Battery Fluid)

## ELECTROMAGNETIC COMPATIBILITY SPECIFICATIONS

	ISO 11452-2 ALSE	80 MHz - 1000 MHz, 200V/m
	ISO 11452-2 ALSE	1000 - 2500 MHz, 200V/m, 3-axis
Radiated Immunity	ISO 11452-3 TEM cell	0.01 - 200 MHz, 300V/m
	ISO 11452-4 Bulk current injection	0.5 MHz - 400MHz, 300mA
	ISO 11452-5 150 mm Stripline	0.01 MHz - 400MHz, 300V/m
Electrostatic Discharge	ISO 10605 8 powered-up test	ESD Capacitor Network 330pF, 330Ω Conductive Surfaces Contact Discharge +/-15kV Non-Conductive Surfaces Air Discharge +/-25kV Indirect Discharge +/-20kV
Electrostatic Discharge	ISO 10605 9 unpowered test	ESD Capacitor Network 150pF / 2kΩ Conductive Surfaces Contact Discharge +/-15kV Non-Conductive Surfaces Air Discharge +/-25kV Indirect Discharge +/-20kV
Magnetic Field Immunity Test	ISO 11452-8:2007	15 Hz - 1000 Hz, 100 A/m, Class A 1 kHz - 10 kHz, 100/(F/1000) <sup>2</sup> , Class A 10 kHz - 150 kHz, 1 A/m, Class A
Radiated Emissions: Broadband/Narrowband	ISO14982 CISPR 25 (where frequency bands are specified)	CISPR 25 Class 5 where specified Class 3 - Average, Peak and Quasi Peak (where specified), on remaining CISPR 25 defined bands
Conducted Emissions	CISPR 25 6.2	Class 5