



DURACODE 260-P

DURACODE 260-PIGMENT CONTINUOUS INKJET PRINTER

The 260P is engineered to consistently print bright, crisp, and precise codes with high contrast pigmented inks. Designed for applications that require high visibility codes on dark or difficult materials. Capable of printing text, symbols, custom logos, graphics, 2-D & 1-D barcodes.



INCLUDED WITH PRINTER

- Remote service
- Manuals
- Printhead holder
- Starter tool kit

EASE OF USE

- Out of the box input capability with scanners
- Specifically designed to work with pigmented inks
- Startup and shutdown are simplified with icon-driven options

FLUID MANAGEMENT

- Fluid addition is easy, clean, quick, and chipped cartridges ensure precise fluid use.
- Intelligent long-term or short-term automatic shutdown to keep the system ready for future use

OPERATION AND MAINTENANCE

- Cut service costs with DIY single combined filter pack
- Automatic modulation and printhead cleaning
- Informative display shows fluid levels and WYSIWYG



PRINTING QUALITY

- Over 20 pigmented ink options guarantee a fit with your application
- .07-50mm, 34 verticle drops, free choice of print matrix

For additional information, contact InkJet, Inc. at
1-800.280.3245 or **sales@inkjetinc.com**
Videos, photos & specs at: **www.inkjetinc.com**

DC 260-P HIGH CONTRAST CODING PRINTER

THE DETAILS

DURACODE CIJ SPECIFICATIONS

Screen	7" LED
Printhead	Temperature control printhead, Diameter 41mm
Umbilical	Length 2700mm, Bending radius 150mm
Nozzle diameter	50/60/70um
Electricity	100-240 VAC 50-60 HZ
Power	Rated power: 70w
Operation temperature	5-45°C
Protection level	IP55
Information editing	Multiple Language Input
User field	QR Code, Bar Code, Pattern, Clock counter and shift etc.
Optional interfaces	Three-color warning light, RS232 serial port, IO expansion module
Print height	1.2-10mm
Print lines	1-5 lines
Maximum print dot matrices	34 dot
Contact-free print distance	Nominal 2-15mm. Optional up to 50mm with quality print option
Fastest print speed	320m/min (60um model)
Selectable dot matrix fonts	5x5, 7x5, 9x6, 8x8, 11x8, 12x11, 15x12, 16x11, 24x16, 32x22, 9x6(bold), 11x8(bold), 6x5, 7x4
Addition of consumable	Plug in cartridge with smart chip. 375ml Ink and 750ml Makeup
Standard ports	Optical sensor, Encoder, Ethernet
Accessories	Cart, Alarm Beacon, Printhead Holder
Weight	Net weight: 27Kg Grows weight: 40Kg (Including accessories and packing box)



Dimension(mm)

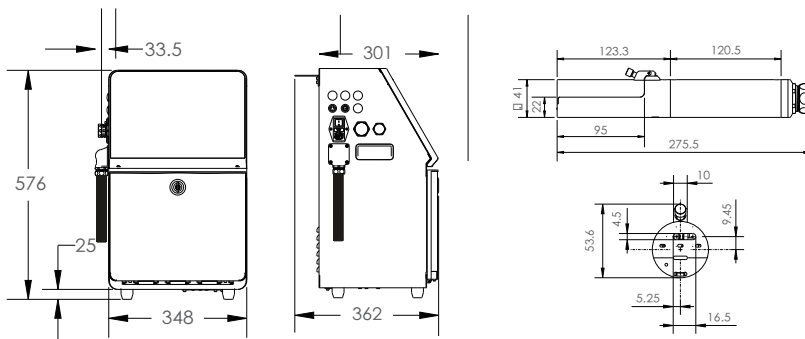

For additional information, contact InkJet, Inc. at
1-800.280.3245 or **sales@inkjetinc.com**
 Videos, photos & specs at: **www.inkjetinc.com**