



ASSEMBLY INSTRUCTIONS & OWNERS MANUAL

First of all, we would like to thank you for choosing the VoltBike electric bike. It all started in our garage with a mission. To bring North America premium electric bike at half the price compared to your local department store.

On a sunny day in the spring of 2013, our team watched – and cheered – as Voltbike’s very first bike were pedaled out the door by happy customer. Since that day we’ve shipped thousands more to Voltbike riders all over North America.

Today VoltBike is situated on 22000 sqft warehouse facility in Port Coquitlam, BC, Canada and 2000 sqft shipping depot at Blaine, WA, USA. We ship non-stop, everyday all over Canada and the USA.

If you have any concerns, questions or suggestions about the VoltBike electric bike, please contact us at sales@voltbike.com.

You can download the latest version of this manual at www.voltbike.com/manuals.

Additional information about your VoltBike can be found in our Help Center at www.voltbike.com/help-center.

Again, thanks for choosing VoltBike!

IMPORTANT

Electric Bikes can be dangerous to use. Like any sport, bicycling involves risk of damage, injury, and death. By choosing to ride a electric bike, you assume the responsibility for that risk, so you need to know, and practice the rules of safe and responsible riding and the proper use and maintenance of this bike. Proper use and maintenance of your bike reduces risk of damage, injury, and death.

As with all mechanical components, the bicycle is subjected to wear and high stresses. Different materials and components may react to wear or stress fatigue in different ways.

If the design life of a component has been exceeded, it may suddenly fail possibly causing injuries to the rider. Any form of crack, scratches or change of coloring in highly stressed areas indicate that the life of the component has been reached and it should be replaced.

This manual contains critical details about how to safely operate and maintain your VoltBike. Read it carefully and familiarize yourself with your ebike before riding it.

For replacement parts, technical information and warranty assistance, please contact VoltBike at 1.800.350.4840 or www.voltbike.com/support.

PLEASE NOTE: THIS MANUAL IS NOT INTENDED AS A DETAILED USER, SERVICE, REPAIR OR MAINTENANCE MANUAL. PLEASE SEEK ASSISTANCE FROM A QUALIFIED TECHNICIAN FOR SERVICE, REPAIRS OR MAINTENANCE.

BEFORE RIDING, ENSURE YOU HAVE ALL REQUIRED AND RECOMMENDED SAFETY EQUIPMENT AND ARE FOLLOWING ALL LAWS PERTAINING TO USE AN ELECTRIC BIKE IN YOUR REGION.

ASSEMBLY INSTRUCTIONS



Assembly and first adjustment of your bike from VoltBike requires tools and skills. We recommend that you have this done by certified or experienced bike mechanic.

The following steps are only a general guide to assist in the assembly of your ebike and are not a complete or comprehensive manual of all aspects of assembly, maintenance, and repair. Consult a certified, reputable bike mechanic to assist with assembly, repair, and maintenance of your ebike.

1. Remove the outside carton after cutting the nylon bands. Remove all of the inside cardboard protection and bubble wrap. Carefully remove your bike from the carton and gently rest it in place with the kickstand down.
2. Ensure the following pieces are included in the package. If there are any missing parts please contact VoltBike for help.
 - VoltBike electric bike
 - Pedals (Left and Right)
 - Charger
 - Key for battery pack (usually attached with plastic tie either on the handlebar or on the battery)
 - Assembly tools and manual
 - Helmet (free with purchase of VoltBike)
3. If necessary, align the stem with the front wheel and tighten the top stem bolt enough to hold the stem in

place. Once the handlebars are aligned and the top bolt is slightly secured, firmly tighten the 2 side bolts on the stem. After tightening the 2 side bolts, firmly tighten the top bolt. After all 3 bolts have been securely fastened, make sure there is no play in the headset. (See picture below)

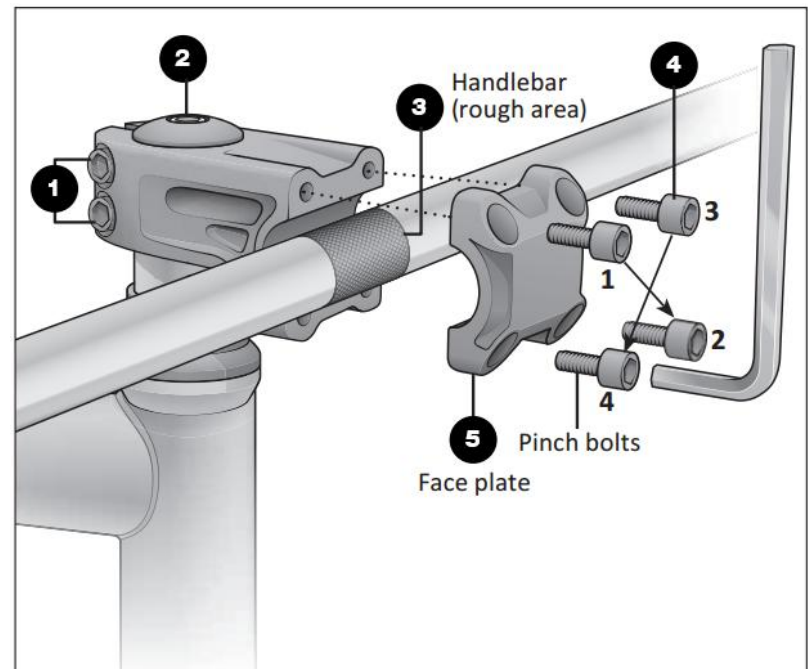

4. Using the 15 mm wrench provided in the tool kit, attach and tighten the pedals. PLEASE NOTE – The pedals are marked “L” for Left and “R” for Right. The left pedal is attached by turning it counterclockwise and the right pedal is tightened by turning it clockwise. Make sure the

pedals are tightly attached to the crank arms to prevent stripping. Torque each pedal to 35 Nm. (see picture below).

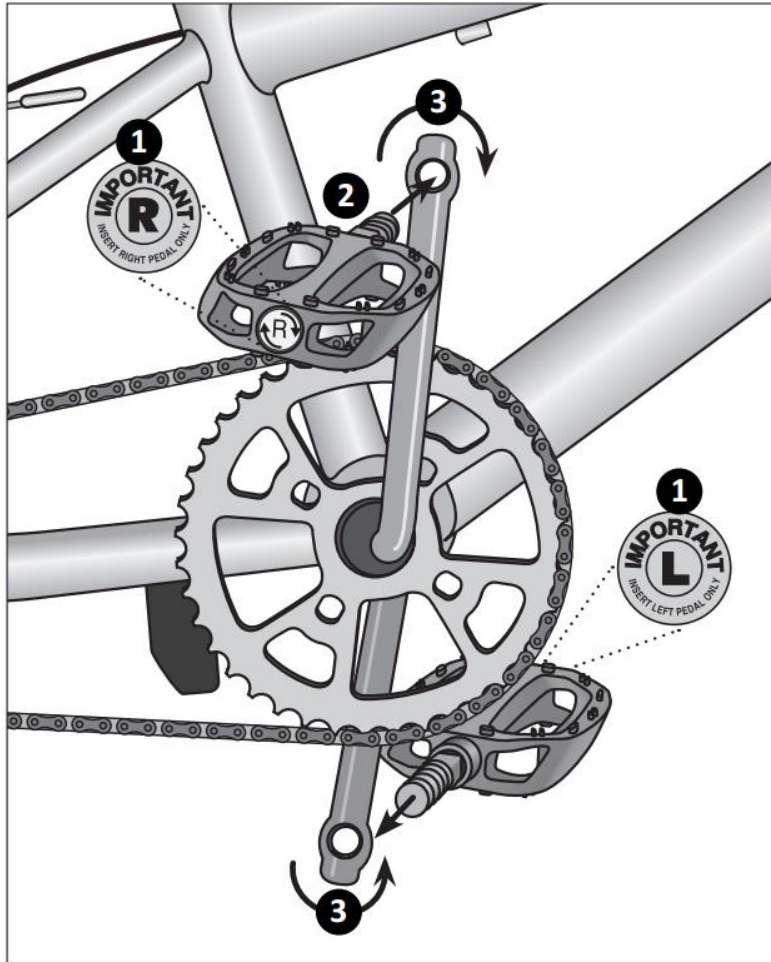

5. Make sure the seat is tight enough so that you can't twist it out of alignment. Pull the seat clamp handle away from the seat post and slide the seat up or down to adjust it.

Move the clamp handle inward toward the seat post so it is held tight by the clamp.

Important! Be sure the minimum insertion marks do not go past the top of the seat clamp and are not visible.

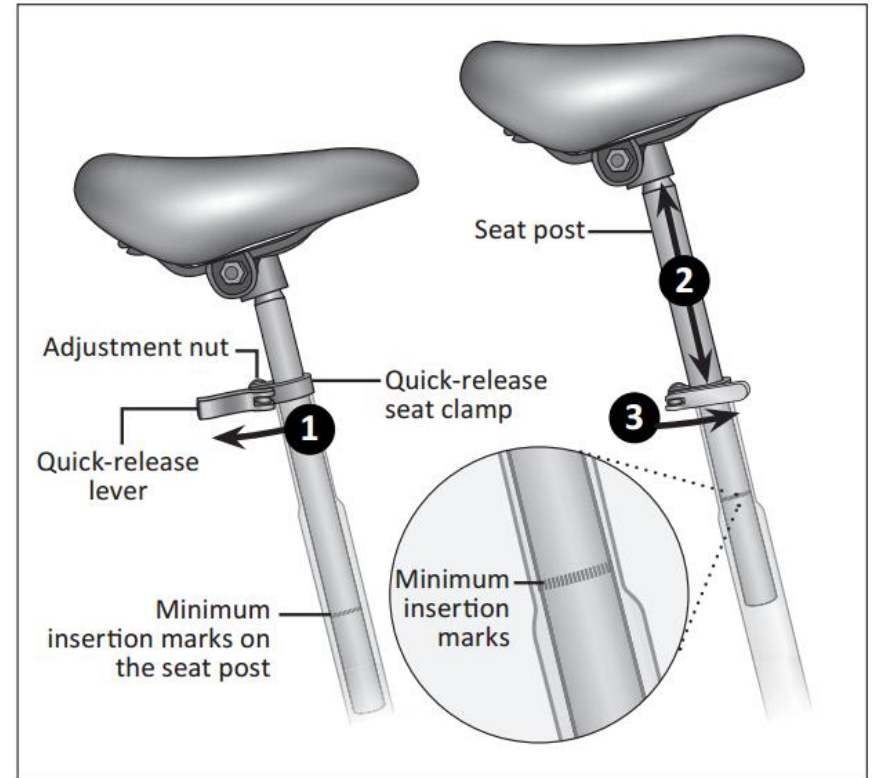

! A loose seat clamp or seat adjustment bolt can cause loss of control, bike/property damage, serious injury, or death. Regularly check to make sure that the seat adjustment bolt is properly tightened and the clamp is secure on the seat rails.

6. Check the security of the front wheel and quick-release lever. If it's too easy or too difficult to close, adjust the lever tension by turning the thumbnut one turn, then close the lever. The front wheel should always be fully seated in the dropouts of the front fork. Check the front wheel security on a regular basis!



An improperly secured front or rear wheel can cause loss of control, accidents, serious injury, or death. Check that both wheels are properly secured during assembly and before each ride.

7. Inflate tires. Check that the tire beads and tires are evenly seated around the rims. Use a pump with a Schrader valve and pressure gauge to inflate each tire to the recommended PSI (pounds per square inch) indicated on the tire sidewall. Do not overinflate or underinflate tires.
8. Make sure handlebar cables were routed correctly when the handlebar was installed. Turn the handlebar fully to the left and right and make sure this doesn't pull any of the cables or wires taut.

BATTERY CHARGING

Included with your new VoltBike is a lithium ion battery, along with a charger, which plugs into a standard household electric receptacle. A lithium ion battery requires specially designed

chargers. You should never charge your battery with a substitute charger that is not designed for this use.

Your VoltBike battery arrives with 70% charge. It is recommended that you fully charge the battery before your first use. The VoltBike battery may be charged while on the bike or removed and charged at a location away from the VoltBike. To charge the battery please follow the steps below:

- Ensure the bike is off.
- Inspect the battery, charger, and electrical cables for damage. If everything looks fine, proceed with the rest of the steps. If you find any damage, don't charge your bike and contact VoltBike.
- Remove the rubber cover on the battery charging socket.
- Place the charger in a flat, dry, secure place, and connect the DC output plug from the charger (round barrel connector) to the charging port on the side of the battery pack.
- Plug the charger into a power outlet. (110/220-volt plug). *Always plug charger output plug to the battery before connecting the charger to the power outlet.*
- The indicator light on the charger will be red when battery is charging and will turn green when fully charged.
- We recommend removing the charger from the battery within one hour of the green light indicating a complete charge. The charger is designed to automatically stop charging when the battery is full,

but unnecessary wear of the charging components could occur if the charger is left attached to the battery and a power source for longer than 12 hours.

- Once the battery is fully charged, unplug the charger from the wall outlet first and then remove the charger output plug from the battery charging port.

The charger will charge a fully depleted battery in 5—6 hours. Never charge a battery for more than 12 hours at a time. If the battery will not be used for an extended period of time, charge it fully and recharge it at least once per month. Store it in a cool, dry place. If you experience unusual sounds or odors coming from the charger or the battery, unplug charger immediately and contact VoltBike customer service.

CRITICAL BATTERY SAFETY

- Always charge your battery where you can monitor it. Letting a battery charge unattended increases the risk that a charging problem will go undetected and lead to a fire hazard.
- Check that the battery and charger are undamaged before charging. If the battery or charger look damaged or were involved in a fall or crash (even without outward or obvious signs of damage) do not attempt to charge and contact VoltBike immediately.
- Recharge battery after every use. This will keep the battery in good shape for longer time.

- Do not allow any liquids near or inside the battery charger.
- Always plug the charger into the battery's charging port, before plugging charger into power outlet.
- Do not charge the battery with any other chargers than what was originally supplied with your VoltBike.
- Fully charge the battery before each use to extend the life of the battery and help to reduce the chance of over discharging the battery pack.
- Do not place the battery near fire or corrosive substances.
- Charge your battery in a temperature controlled, dry, safe location ideally at room temperature, 10°C to 25°C (50°F to 77°F)
- The charger should only be used indoors.
- DO NOT cover up the charger while it is charging. The charger air cools and needs to be on a hard, flat surface in an open space. Use the charger with the indicator light facing upward.
- If the battery is physically damaged, non-functional, performing abnormally, or was dropped or involved in a crash, with or without obvious signs of damage, please discontinue use and charging and contact VoltBike immediately.

Store the charger unplugged, making sure its plug does not come in contact with liquids, dirt, debris, or metal objects, which can damage the plug and interfere with future operation.

OPERATION

Your VoltBike is equipped with an LCD meter that monitors pedal assist, speed, odometer, trip distance, riding time, and battery energy level. To turn the meter on, make sure the battery is fully inserted into the VoltBike battery holder (for VoltBike Yukon) or the battery on/off switch is in the ON position. (for VoltBike Mariner and Voltbike Urban).

NON-COLOR LCD SCREEN

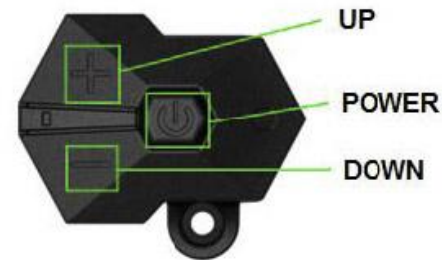
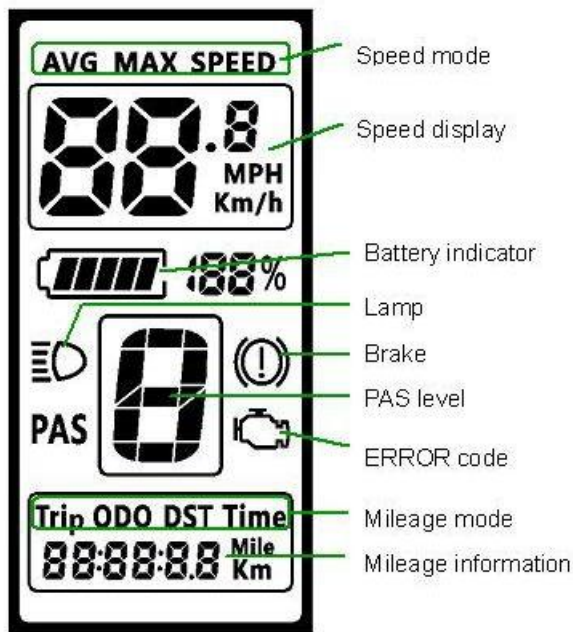

Hold the power button (middle button) for 1.5 seconds. The power button is located on the 3 buttons selector located on the left grip on the handlebar. The display will automatically shut down after few minutes if there is no riding activity.

Please never press all 3 buttons on the same time. This will reset the LCD firmware and the battery level indication on the LCD screen will start flashing.

METER PROGRAMMING AND USE

- **Assist Level:** To change the pedal assist level you can short press **Up/Down** button. The highest assist level is 9 and the lowest is 1. You can also program the display so there is 0 level pedal assist which is neutral. See below for instructions.
- **Headlights/Backlights:** To turn on/off the lights on your bike you have to press the **Up** button for 1.5 seconds.
- **Cycle through readings:** Short press Power button will cycle through various readings on the LCD display: Speed
 - ▶ AVG Speed ▶ Max Speed ▶ Trip ▶ Odometer ▶ Time

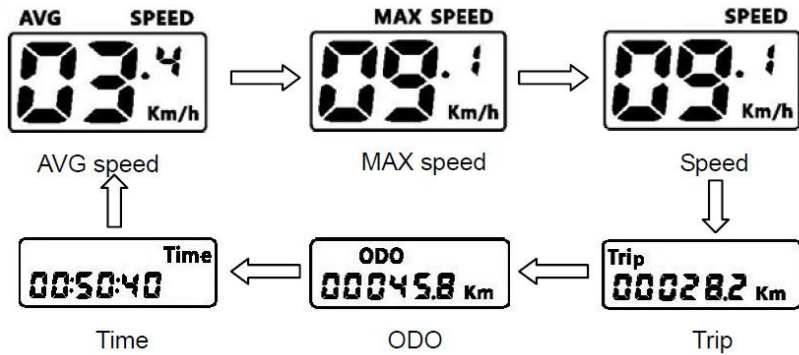

- **Data Clean:** If you press **Up/Down** buttons both together for few seconds, this will reset several temporary data including AVG Speed, MAX Speed, Trip and Time.
- **Walking Mode:** Press and hold **Down** button will get in 6km/h walking mode. This is useful if you plan to walk with your bike uphill.
- **Advanced Settings:** Double pressing power button in interval less than 0.3 sec. will get you into parameter setting mode. From here you can set various parameters like wheel diameter, system voltage and switch km/h to mp/h.

Once you are into advanced mode you can short press **Up/Down** buttons to change parameter value, short press power button to switch to the next parameter. The meter will automatically exit and save if there is no activity for 10 seconds.

The order of parameters is as follow:

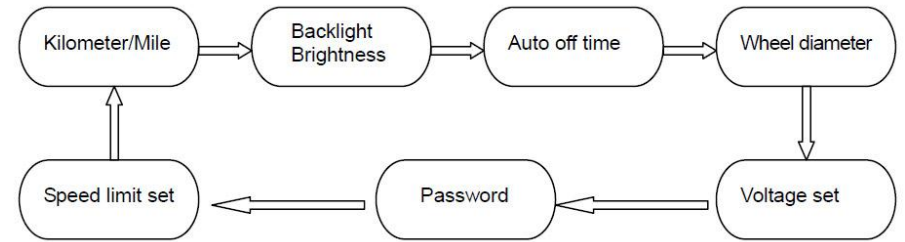

Kilometer/Mile – Symbol on display S7. Press **Up/Down** to rotate between mph and km/h.

Backlight brightness – Symbol on display bL1. Press **Up/Down** to rotate between levels 1- 5

Auto OFF delay time – Symbol on display OFF. Press **Up/Down** to change the value from 1 to 9 which represents delay time in minutes before the display shutdown due to inactivity.

Wheel diameter – Symbol on display Wd. You can choose between 16/18/20/22/24/26/700C/28/29. Wrong value for wheel diameter will cause speed measurement abnormality.

Battery voltage - Symbol on display bU0

Password – In order to proceed to speed limit parameter you need to enter password. Default password is 1919.

Speed limit – Symbol on display SPL. Press **Up/Down** to change the value.

Please don't change settings if you are not confident enough. Setting improper wheel diameter or voltage setting may cause malfunction of your bike.

In case of malfunction the VoltBike LCD control panel will display error code. The error codes are in the range between 01E -07E. The error code number is accompanied with the symbol below:



Error Code	Error Description	Solution
01E	Communication error	Check cable connection
02E	Controller protection	Check three-phase power line
03E	Three-phase power error	Check the three-phase power line connection
04E	Battery low	Charge the battery
05E	Brake error	Check brake power cut inhibitor
06E	Turn error	
07E	Hall error	Check the hall connection
08-99E	Reserved	Please contact manufacturer for error definitions

COLOR LCD SCREEN



For detailed manual on this display please visit

<https://www.voltbike.com/manuals>

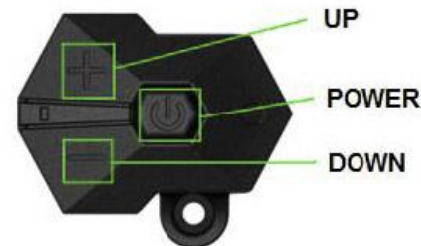

Press the power button (left button) on the four button selector located near the left grip on the handlebars to turn the meter on. You can adjust the pedal assist power level to have more power by hitting the [+] button (top button) and can move to a lower level power by hitting the [-] button (bottom button).

METER PROGRAMMING AND USE

- **Assist Level:** To change the pedal assist level you can short press **Up/Down** button. The highest assist level is 9 and the lowest is 1. You can also program the display so there is 0 level pedal assist which is neutral. See below for instructions.
- **Headlights/Backlights:** To turn on/off the lights on your bike you have to press the **Up** button for 1.5 seconds.
- **Cycle through readings:** Short press Power button will cycle through various readings on the LCD display: Speed
▶ AVG Speed ▶ Max Speed ▶ Trip ▶ Odometer ▶ Time
- **Data Clean:** If you press **Up/Down** buttons both together for few seconds, this will reset several temporary data including AVG Speed, MAX Speed, Trip and Time.
- **Walking Mode:** Press and hold **Down** button will get in 6km/h walking mode. This is useful if you plan to walk with your bike uphill.

- **Advanced Settings:** Double pressing power button in interval less than 0.3 sec. will get you into parameter setting mode. From here you can set various parameters like wheel diameter, system voltage and switch km/h to mp/h.

ADVANCED SETTINGS

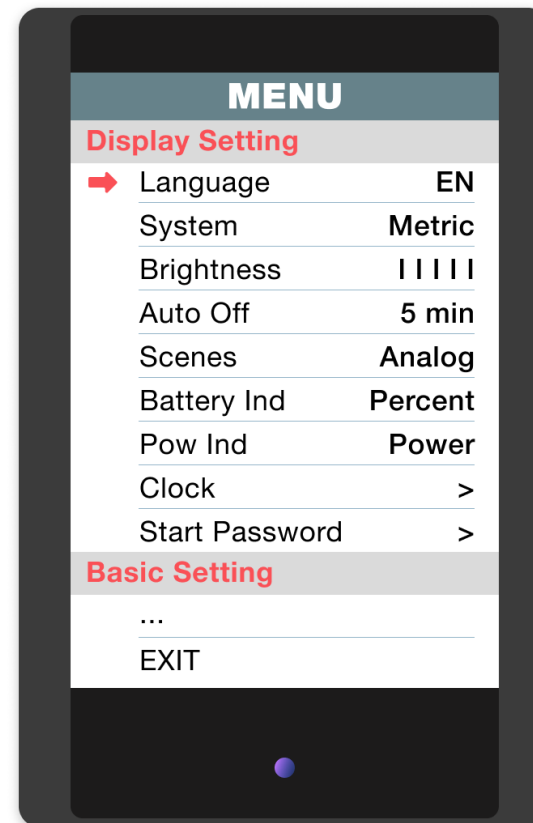

System - Press **Up/Down** to switch between Metric / Imperial.

Brightness - Press **Up/Down** to change the brightness of the backlight.

Auto Off - Press **Up/Down** to change the value from 1 to 9 which represents delay time in minutes before the display shutdown due to inactivity

Scenes - Press **Up/Down** to change the scenes, Digital / Analog. This display only supports Digital scenes at the moment.

Battery Ind - Press **Up/Down** button to change the battery indicator, Voltage / Percentage / OFF.

Pow Ind - Press **Up/Down** button to change the Power indicator, Analog / Digital. This data represents the power output of the battery (not motor).

Clock - Clock setting, press **POWER** button get into the clock setting menu, press **Up/Down** to set Year/Month/Day/Hour/Min/Sec

Start Password - Press **POWER** button to get into the password setting menu. If you set **Start Input** ON, then you have to type the correct password every time you power on your bike.

For detailed manual on this display please visit <https://www.voltbike.com/manuals>

START-UP PROCEDURE



Users must become accustomed to the bike's power control system before operating. The pedal assistance/throttle feature is a powerful option and users should fully research and understand how to operate it before first use. Not taking the time and care to familiarize yourself and practice the operation of the power system on your bike from VoltBike can lead to damage, serious injury, or death.



Always wear an approved bicycle helmet whenever riding a bike. Riding any bike without a helmet puts you at very high risk of serious head injury or death.

After the bike has been properly assembled, a certified, experienced mechanic has checked the assembly, and you have read this entire manual you can proceed to the following steps:

- Press the power button for about two seconds until the LCD display turns on.
- Keep at least one hand ready to squeeze the brake lever to cut off power to the motor in case of emergency.
- For your first test ride we do recommend to start with pedal assist level 0 until you get comfortable with your VoltBike. Begin by pedaling on flat ground, clear of obstacles and people, with the bike in an easy (low) gear.
- Use the throttle (next to the right handlebar grip) by slowly and carefully rotating it toward the rider. Only use the throttle when you're seated on the bike and

prepared for it to move forwards. Note that the throttle can be engaged any time the bike is powered on unless you have a model that includes a throttle on/off switch, which you can use to prevent the throttle from activating motor assistance.

- When you finish riding immediately power off the bike to prevent accidental throttle or pedal assist activation.

Be careful not to accidentally twist the throttle, which can cause sudden acceleration. If you're not prepared for this acceleration, you can lose control of the bike, which can lead to serious injury or death. To minimize this risk, always keep at least one hand ready to squeeze the brake lever to cut off power to the motor.

MAINTENANCE

Always check the condition of your bike before you ride in addition to having regular maintenance performed. If you are unsure of how to conduct a complete check of the condition of your bike before every ride, you should consult a certified, experienced bike mechanic for assistance.

Before every ride, and after every 25-45 miles (40-72 km), we advise following the pre-ride safety checklist:

- Ensure that the brakes and their system components are free from damage, properly secured and working

correctly. When fully squeezed, both front and rear brake levers should not be touching the handlebar.

- Check the operation of your brake inhibitor switches before every ride.
- Your wheels should always spin straight and must be repaired or replaced if they wobble side to side or up and down when spinning. If your wheels become untrue or spokes loosen, which can happen with normal use, we recommend that a certified, reputable bike mechanic performs all wheel tuning and truing operations on your bike.
- Ensure the tires and inner tubes are in good working condition without any visual damage and have the correct amount of air pressure.
- Ensure the handlebar and handlebar stem are properly aligned, fitted to the user, and secured to their recommend torque values. Handlebar grips should not move easily on the handlebar end.
- The torque and security of all wheel mounting hardware should be inspected on a regular basis. Both wheels need to be properly secured before operating your bike. Either wheel can become loose or unsecured with normal use.
- Ensure pedals are securely tightened to the cranks.

WARNINGS AND SAFETY

You should check the operation of your brake inhibitor switches before every ride. While riding slowly in a controlled environment (like a driveway), engage the motor, then squeeze each brake in turn. The motor should lose power immediately and remain off as long as a brake lever is depressed.

Always use the lowest assist setting until you are comfortable with the bike and feel confident controlling the electric assist.

Keep your hands on the brake levers, and remember that they will always slow or stop the bike if pulled.

Use only the battery provided with your bicycle. Even if it is physically possible to connect another type of battery, it is dangerous and potentially damaging to do so.

Never short circuit on the discharge terminals of the battery. A short circuit will damage the battery and could cause a fire resulting in severe injury or death, and property damage. When handling the battery outside the bicycle, be aware of conductive materials that may short the battery terminals, such as coins, nails, etc.

VoltBike is designed for use by persons 18 years old and older. Riders must have the physical condition, reaction time, and mental capability to ride safely and manage road conditions, and sudden situations, as well as respect the laws governing electric bike use where they ride, regardless of age.

Electric bikes are faster and heavier than normal bikes. When riding in wet weather, you should use extra caution.

Local laws may prohibit the use of high speed electric bicycles on bike paths or trails. Be sure you are familiar with the laws in your area. Even if legal, it is usually not safe to ride at high speed on paths or trails around other users.

Like any mechanical device, a bicycle and its components are subject to wear and stress. Different materials and mechanisms wear or fatigue from stress at different rates and have different life cycles. If a component's life cycle is exceeded, the component can suddenly and catastrophically fail, causing serious injury or death to the rider.

Scratches, cracks, fraying and discoloration are signs of stress-caused fatigue and indicate that a part is at the end of its useful life and needs to be replaced.

Electric Bikes can be dangerous to use. The user or consumer assumes all risk of personal injuries, damage, or failure of the bicycle or system and all other losses or damages to themselves and others and to any property arising as a result of using this bicycle.