



INSTALLATION INSTRUCTIONS
Part # SK4550
O-ring Service Kit
for Jagg HyperFlow Oil Filter Adapter

Please read these instructions completely before beginning installation.

KIT CONTENTS

QTY.	DESCRIPTION
2	Quad-seal O-ring for oil filter mount surface

INSTALLATION

1. Allow vehicle to cool completely. Remove spin-on oil filter and clean the oil filter landing of oil and debris.
2. Remove extension screw from center of sandwich adapter plate and remove sandwich adapter plate from oil filter housing.
3. Remove old O-ring from rear of sandwich adapter plate.
4. Lubricate quad-seal O-ring with oil and insert into O-ring groove on rear of sandwich adapter plate.
5. Match sandwich adapter plate onto engine's oil filter landing.
6. Insert extension screw through sandwich adapter plate center and thread onto engine oil filter stem.
7. Tighten extension screw to 20 lb-ft (27.1 Nm) or to factory specifications of engine oil filter.
8. Ensure adequate clearance of sandwich adapter plate and adapter fittings around any moving parts, exhaust systems, or sharp edges that could cause hose or component failure or interference.
9. Install engine oil filter to factory specifications.
10. Check extension screw for proper tightness and re-torque if needed, any time an oil filter is removed from the sandwich adapter.

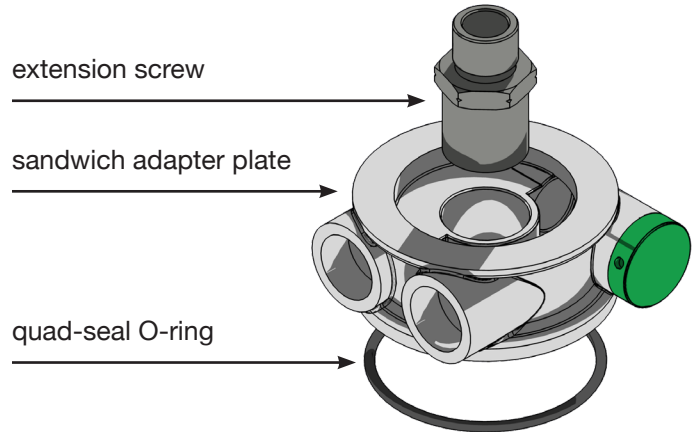

Warning: Installation should only be attempted by those with mechanical skills and experience working on vehicles. Standard safety precautions consistent with the tools and dangers of automotive work should be followed to protect from injury. Specifically, wear protective equipment, take care to stabilize the vehicle on a level surface, engage the parking brake, and allow vehicle to cool before attention installation; failure to comply can result in injury and/or damage to equipment.