



INSTALLATION INSTRUCTIONS

Part # 751-FP2500-0323

Please read these instructions completely before beginning installation.

KIT CONTENTS

QTY.	DESCRIPTION
1	Jagg FP2500 Fan-assisted oil cooler assy.
1	Jagg 4702 Offset Oil Filter Adapter Body
1	Jagg 4702 Offset Oil Filter Adapter Faceplate
3	10-24 x 5/16" countersunk flat-head hex-drive screw for 4702 Faceplate
1	Jagg 4702 steel LOCNUT with 3/8" ratchet cutout
1	Large O-ring, square profile
1	1/8" NPT pipe plug
2	Adapter fittings - 1/8" NPT to 3/8" push-on hose barb
4	7/8" black wormdrive hose clamps
1	Anti-rotation device
2	10-24 x 5/16" button-head hex-drive screw for anti-rotation device
1	Jagg automatic fan switch, 190°F
1	Street-tee pipe fitting, NPT1/8 male to 2xNPT1/8 female
2 ft	Jagg 30R7spec black oil hose
1	Wiring harness for Jagg WeatherTek fan, 45"
45 in	Convolutted wire cover
3	Plastic zip-ties

TOOLS REQUIRED

Strap wrench or oil filter removal tool
3/8" ratchet & ratchet extension
Deep well sockets: 7/16", 7/8"
Hex key tools: 1/8", 1/4"
Hose cutter or sharp knife
1/4" nut driver for hose clamps
Needle-nose pliers
Teflon pipe sealant (e.g., Loctite 592)
Dielectric grease

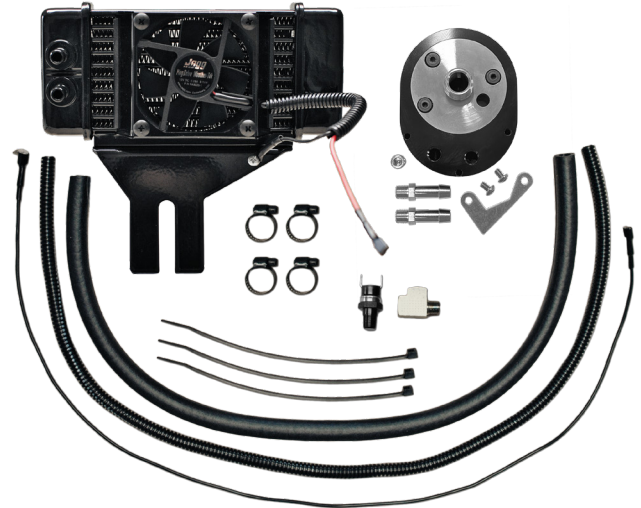

Operation Summary

The Jagg #4702 offset oil filter adapter is used to access the oil supply for the installation of a Jagg oil cooler. The #4702 directs oil through the filter first for optimal flow characteristics. After filtration, the oil may either travel to the oil cooler or by-pass the oil cooler, according to the built-in Viscosity Regulated Flow (VRF) plug function. Cold, viscous oil will by-pass the oil cooler, speeding warmup to standard operating temperature.

As the engine reaches operating temperature and oil reaches optimal viscosity range, the VRF plug will keep the #4702's by-pass hole closed, sending hot, filtered oil to the oil cooler, and delivering cool, clean oil to the engine.

Oil flow direction from adapter: oil feeds the oil cooler from the fitting on the left side and returns to the fitting on the right side, as viewed from front with oil filter adapter fittings at bottom.

Part 1: Install Jagg Offset Oil Filter Adapter

Pre-installation steps

1. Remove spin-on oil filter, and clean the filter mounting surface thoroughly.
2. Using a 7/8" deep well socket, remove the stock oil filter stem. If removing and upgrading

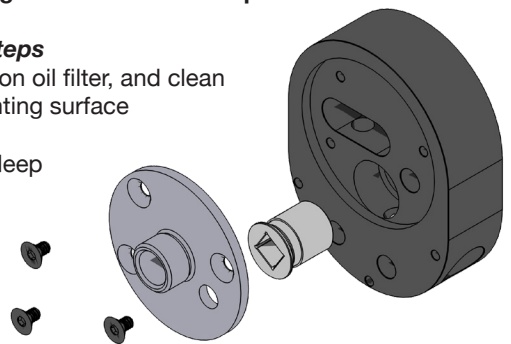

Warning: Installation should only be attempted by those with mechanical skills and experience working on vehicles. Standard safety precautions consistent with the tools and dangers of automotive work should be followed to protect from injury. Specifically, wear protective equipment, take care to stabilize the vehicle on a level surface or supportive lift, and allow vehicle to cool before attemptation installation; failure to comply can result in injury and/or damage to equipment.

a factory Harley-Davidson oil cooling system, uninstall the stock oil filter adapter by removing the flanged oil filter nipple that holds the adapter in place using a 7/16" hex key tool.

- Disassemble the 4702 by removing the three countersunk flat-head hex-drive screws from the front face of the adapter using a 1/8" hex key tool. Then, remove the faceplate from the adapter and remove the LOCNUT from within.

Installing NPT pipe plug

- Apply Teflon pipe sealant (e.g., Loctite 592) to male pipe threads if not pre-applied. If PTFE tape is used, it should be wrapped 1-1/2 to 2 turns in clockwise direction when viewed from the pipe thread end.

CAUTION: If PTFE tape is used, more than two turns of tape may cause distortion or cracking of the port.

- Screw the NPT plug into the port to finger tight.

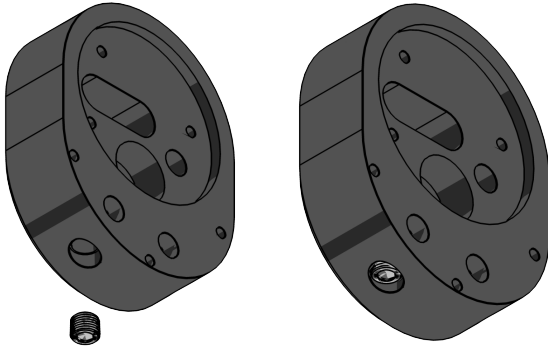

- Wrench tighten the plug to 2-3 turns-from-finger-tight (T.F.F.T.).

Installing the automatic fan switch

The Jagg WeatherTek fan operates via the included automatic fan switch. The automatic fan switch installs into the included street-tee pipe fitting to access hot oil flow from the oil filter adapter to activate the fan.

Oil flow from the adapter feeds the oil cooler from the fitting on the left side and returns to the fitting on the right side, as viewed from the front with the oil filter adapter fittings at the bottom.



Automatic fan switch

3

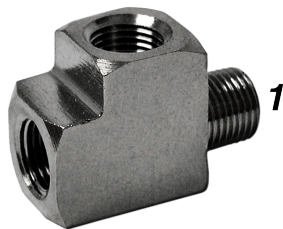

Street-tee pipe fitting

- Apply Teflon pipe sealant (e.g., Loctite 592) to the 1/8" male pipe threads on one of the provided hose barb adapter fittings.
- Install one hose barb adapter fitting into female port #2 of the street-tee pipe fitting to finger tight.
- Wrench tighten the hose barb adapter fitting to 2-3 turns-from-finger-tight (T.F.F.T.).
- Apply Teflon pipe sealant to the 1/8" male pipe thread on the

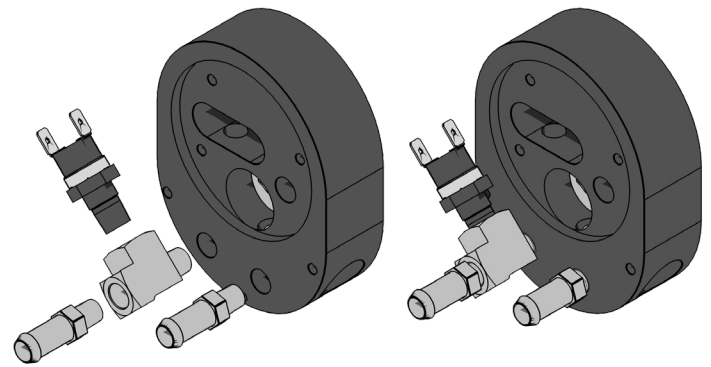

#1 male port of the street-tee pipe fitting.

- Install the #1 male port of the street-tee pipe fitting into the left port of the oil filter adapter to finger tight.

TIP: At this time, test fit the oil filter adapter to the motorcycle to determine the proper "clocking" orientation of the street-tee pipe fitting and fan switch to ensure clearance of any obstruction. See image at right for approximate position.

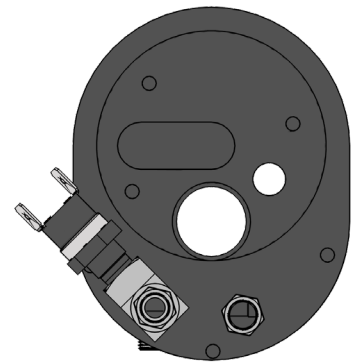

- Once a final position is determined, wrench tighten the fitting to 2-3 turns-from-finger-tight (T.F.F.T.) to arrive at the desired position.
- Apply Teflon pipe sealant to the 1/8" male pipe thread on the automatic fan switch.
- Install the 1/8" male pipe thread end of the automatic fan switch into the #3 female port of the street-tee pipe fitting to finger tight.
- Wrench tighten the automatic fan switch to 2-3 turns-from-finger-tight (T.F.F.T.).
- Apply Teflon pipe sealant to the 1/8" male pipe thread on the remaining hose barb adapter fitting.
- Install the hose barb adapter fitting into the right port of the oil filter adapter to finger tight.
- Wrench tighten the hose barb adapter fitting to 2-3 turns-from-finger-tight (T.F.F.T.).

Installing 4702 to engine oil filter mount

- Lubricate the large O-ring with a slight smear of oil and insert into O-ring groove on the rear of the 4702 body.
- With the fittings-end of the adapter at the bottom and the O-ring sealing side facing toward the engine, place the 4702 body over

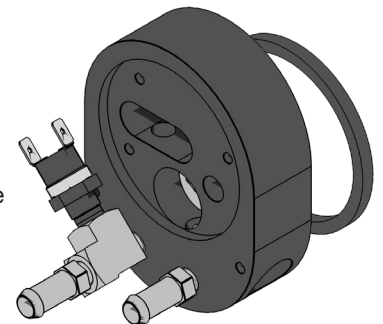

Warning: Installation should only be attempted by those with mechanical skills and experience working on vehicles. Standard safety precautions consistent with the tools and dangers of automotive work should be followed to protect from injury. Specifically, wear protective equipment, take care to stabilize the vehicle on a level surface or supportive lift, and allow vehicle to cool before attemptation installation; failure to comply can result in injury and/or damage to equipment.

the oil filter mount on the engine. Using a 3/8" ratchet extension inserted into the included LOCNUT, insert the LOCNUT through the center hole of the 4702 body and tighten to finger-tight.

21. If an anti-rotation device is being used, locate part #4600AR-C Jagg anti-rotation device now. Installation of this device will ensure the 4702 offset oil filter adapter will not rotate during future oil filter removal.
22. Place the anti-rotation device against the face of the adapter in the orientation shown that matches your motorcycle model.

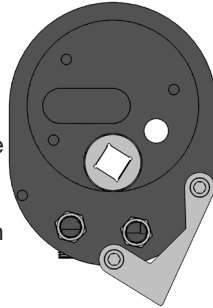

Anti-rotation device fitment

23. Install the two #10-24 button-head hex-drive screws included with the anti-rotation device through the appropriate holes on the oil filter adapter as shown.
24. Rotate the entire adapter counter-clockwise until the anti-rotation device makes contact with the engine case.
25. Using a 3/8" ratchet extension, securely tighten the LOCNUT so the 4702 will not rotate and the sealing O-ring is tight against the stock filter mount.

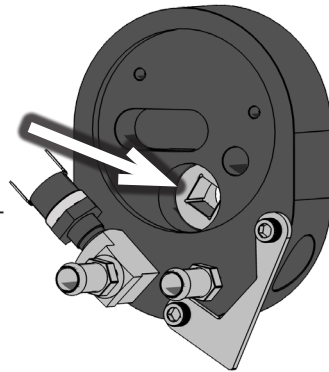

NOTE: On rubber-mounted engine models, allow adequate clearance to ensure that the adapter will not strike any object when the motor shakes.

26. Insert the 4702 Faceplate in the 4702 body and secure it using the three included 10-24 x 5/16" countersunk flat-head hex-drive screws. If using a thread-locking compound, please choose a medium strength and use it on the screws at this step.

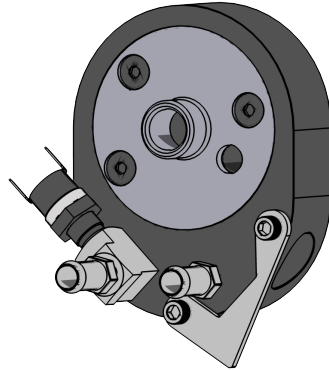

SERVICE NOTE: Inspect adapter and screws for tightness at each oil filter change. To ensure proper seal, replace O-ring any time the 4702 is removed.

Part 2: Oil Cooler Mounting

27. Secure the motorcycle in an upright position.
28. Loosen the two engine mount bolts.

NOTE: DO NOT remove the bolts.

29. Locate the Jagg fan-assisted oil cooler and mounting bracket assembly. With the oil cooler oriented at the top and the oil cooler inlet/outlet pointing toward the rear of the motor-

cycle, install the assembly over the loosened motor mount bolts, sliding the slot of the oil cooler mounting bracket down over the motor mount bolts. Ensure that the oil cooler mounting bracket is behind the lock washers. **(Photo 1)**

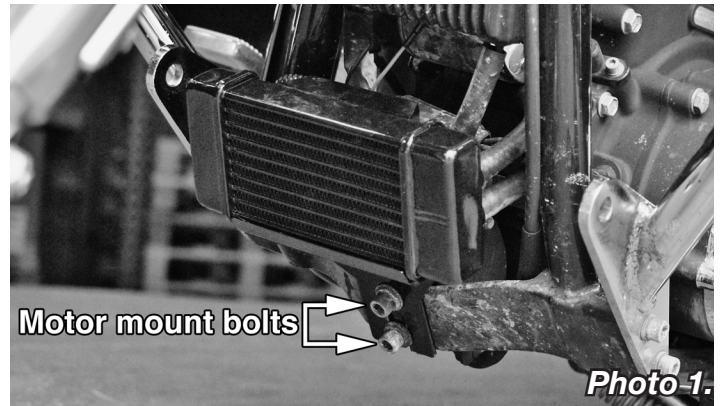

30. Snap the oil cooler assembly downward until the top of the mounting bracket is resting on the motor mount bolts.
31. Tighten the upper and lower motor mount bolts to their final torque value, 21-27 ft.lbs (28-36 Nm).

Part 3: Fan Wiring

FITMENT/INSTALL NOTE:

- Late-model H-D motorcycles with CANBUS electrical systems access power by using the included Deutsche connector in their 6-pin diagnostic port (**SEE FINAL PAGE:** "Supplementary Instructions")
 - All other H-D motorcycles access power by connecting to the rear-brakelight switch, explained below.
32. Install the included convoluted wire cover over the fan wiring harness by inserting wiring into the split. If the wire cover is too long, then it may be trimmed with scissors.
 33. Install the fan wiring harness by connecting the female disconnect onto either prong of the automatic fan switch.
 34. Route the fan wiring harness under the right side (air cleaner side) of the motorcycle along the frame.
 35. Locate the rear brake light switch under the frame and behind your right boot heel as you would sit on the motorcycle. Remove the connector from the "hot" side of the brake light switch **(Photo 2)**.



Warning: Installation should only be attempted by those with mechanical skills and experience working on vehicles. Standard safety precautions consistent with the tools and dangers of automotive work should be followed to protect from injury. Specifically, wear protective equipment, take care to stabilize the vehicle on a level surface or supportive lift, and allow vehicle to cool before attemptation installation; failure to comply can result in injury and/or damage to equipment.

36. Install the “piggyback” dual-connector end of the fan wiring harness onto the “hot” side of the brake light switch.
37. Reinstall the brake light switch connector onto the exposed prong of the “piggyback” dual-connector of the fan wiring harness.

TIP: A liberal coating of dielectric grease spread on the terminals before making electrical connections will help to prevent terminal connection corrosion.

38. Install the fan power lead onto the remaining open prong of the automatic fan switch.
39. Ensure that all installed wiring is clear of the exhaust pipe and use the zip-ties included in the kit to secure the connected fan wiring harness to the motorcycle’s frame.

Part 4: Oil Cooler Plumbing

40. Cut the provided oil hose into two lengths.
41. Install the oil hoses onto the hose fittings on the oil cooler. Using a 1/4” nut driver, secure hose over the fittings with the 7/8” black hose clamps included in the kit so the hose cannot pull over the barb on the fitting. The flow orientation of the oil cooler is non-directional, so either hose fitting will allow proper flow as an inlet or an outlet.

TIP: Install the 7/8” black hose clamps loosely onto the hoses before installing the hoses onto the oil cooler’s fittings. A touch of oil on the barbed fittings will assist in pushing the hoses onto the fittings.

42. Measure, cut, route, and attach the oil hoses to the oil filter adapter fittings. Using a 1/4” nut driver, secure the hoses over the fittings using the 7/8” black hose clamps onto the oil filter adapter inlet and outlet so the hose cannot pull over the barb on the fitting. A touch of oil on the oil filter adapter inlet and outlet allows the hoses to push on easily.

NOTE: It may be necessary to rotate hose clamps to ensure hose clamps do not interfere with oil filter installation.

CAUTION: Take care to make gentle bends in oil hose routing from the oil cooler to the adapter. Sharp bends may collapse under heat load and cause restriction to oil flow.

43. Install oil filter onto the threaded stem of the oil filter adapter. Tighten per factory/service manual recommendations.

Part 5: Final Inspection

44. Inspect the oil hoses to ensure there are no tight bends that may restrict oil flow and that they are not contacting any moving parts. If necessary secure the new hoses to the frame with plastic zip-ties.
45. Refill the engine with the correct amount and type of oil. Check the oil level per factory/service manual recommendations.
46. Start the engine and let it idle. Check all oil hose connections for any leakage. Tighten any hose clamps that may be

leaking.

NOTE: Over-tightened hose clamps may cut into oil lines and cause oil leaks.

47. After installation completion and engine warm-up, shut the engine down and recheck the oil level. Correct the oil level if necessary, but do not over-fill.

SERVICE & UPGRADE ITEMS AVAILABLE	
PART NO.	DESCRIPTION
11-RU77-34	Jagg HyperFlow Lifetime Oil Filters Originally designed for race vehicles, these cleanable/reusable filters employ a stainless steel woven element to offer greater flow and greater filtration than OEM filters.
SK4400	Gasket service kit for Jagg # 4702 offset oil filter adapter Includes: Large O-rings (x2)
21-SSN06-B	Stainless-steel Braided Hose High performance 3/8”(-06) Nitrile rubber oil hose with stainless-steel braided jacket
22-HF06-SI (silver) 22-HF06-BK (black)	Jagg Hose Finishers Hose Finishers with integrated worm-drive hose clamps dress up the terminal ends of your oil hose to resemble high-performance racecar compression fittings without the installation hassle. 7/8” integrated hose clamps, suitable for 3/8” (-06) plain or braided oil hose. Available in black or silver anodized finish.
22-HS06-SI (silver) 22-HS06-BK (black)	Jagg Hose Separators Keep your oil lines separated, provide extra structure, and look trick! Pair with hose finishers for a complete, finished look. Machined from billet aluminum and anodized either bright silver or black, these items install in a snap.
08-0069	Oil Filter Strap Wrench Simply one of the easiest oil filter wrenches to use. Takes virtually no space in the toolbox or the saddlebag.
11-0064	Oil Filter Magnet Catch harmful metals in your oil.

See these items and more at:
www.jagg.com

Warning: Installation should only be attempted by those with mechanical skills and experience working on vehicles. Standard safety precautions consistent with the tools and dangers of automotive work should be followed to protect from injury. Specifically, wear protective equipment, take care to stabilize the vehicle on a level surface or supportive lift, and allow vehicle to cool before attemptation installation; failure to comply can result in injury and/or damage to equipment.

Supplementary Instructions for Jagg Fan-assisted Oil Cooling Systems

- For H-D models with CANBUS controlled electrical systems
- Follow these instructions in place of accessing the power supply at the rear brake light switch to ensure reliable power to accessories

1. Bend and break off the angled tang of the piggyback connector of the power lead.

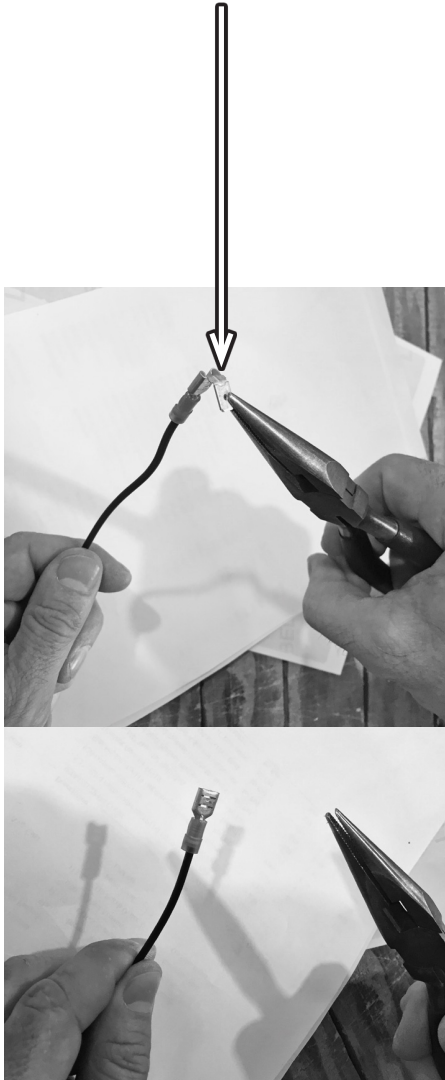

2. Insert piggyback connector as shown below.



3. Plug the Deutsche connector of the power lead into the vehicle's diagnostic port.

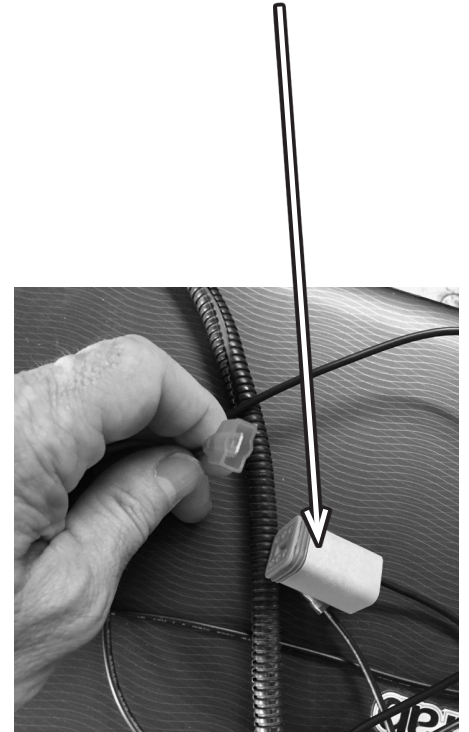

Warning: Installation should only be attempted by those with mechanical skills and experience working on vehicles. Standard safety precautions consistent with the tools and dangers of automotive work should be followed to protect from injury. Specifically, wear protective equipment, take care to stabilize the vehicle on a level surface or supportive lift, and allow vehicle to cool before attempting installation; failure to comply can result in injury and/or damage to equipment.