

3080

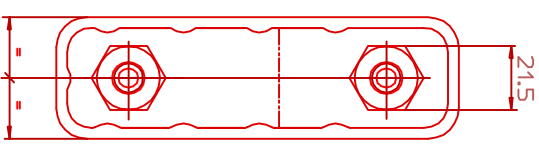

3/8 Push-On

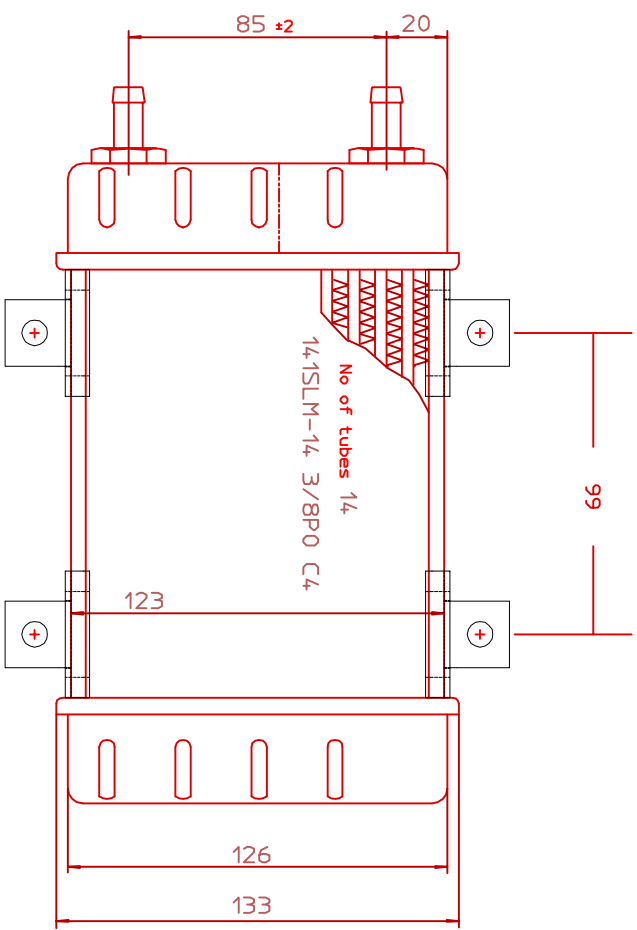
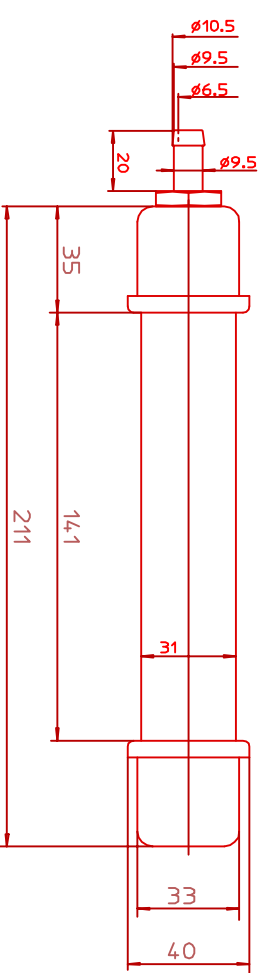

Weight					
Volume	5 BAR				
Working Pressure	10 BAR				
Test Pressure	6 BAR				
Test media					
Test acc to	Paint POWDERCOATED				
Thi/densite of paint					
Connection max Eight torque					
Caution: Tightening must be done with the right torque					
Part no. Qty	4				
Finer/rev	C				
Denomination	OIL COOLER				
Material	AL				
Dimension					
ALL measurements refer to unprinted object					
Part no. 14 ISLM-14 3/8 PO C4					
Tolerances specified	150 2768-V				
Replaces					
Replaced by					
Connected drawings					
Scale	1:1				
Drawing no.	3080				
Customer	JAGG				
Appr					
Drawn	082207 MB				
Contr					
Date/Sign					
Material					
Part no.					
Denomination					
Material					
Dimension					
ALL measurements refer to unprinted object					
Part no. 14 ISLM-14 3/8 PO C4					
Tolerances specified	150 2768-V				
Replaces					
Replaced by					
Connected drawings					
Scale	1:1				
Drawing no.	3080				
Customer	JAGG				
Appr					
Drawn	082207 MB				
Contr					
Date/Sign					
Material					
Part no.					
Denomination					
Material					
Dimension					
ALL measurements refer to unprinted object					
Part no. 14 ISLM-14 3/8 PO C4					
Tolerances specified	150 2768-V				
Replaces					
Replaced by					
Connected drawings					
Scale	1:1				
Drawing no.	3080				
Customer	JAGG				
Appr					
Drawn	082207 MB				
Contr					
Date/Sign					
Material					
Part no.					
Denomination					
Material					
Dimension					
ALL measurements refer to unprinted object					
Part no. 14 ISLM-14 3/8 PO C4					
Tolerances specified	150 2768-V				
Replaces					
Replaced by					
Connected drawings					
Scale	1:1				
Drawing no.	3080				
Customer	JAGG				
Appr					
Drawn	082207 MB				
Contr					
Date/Sign					
Material					
Part no.					
Denomination					
Material					
Dimension					
ALL measurements refer to unprinted object					
Part no. 14 ISLM-14 3/8 PO C4					
Tolerances specified	150 2768-V				
Replaces					
Replaced by					
Connected drawings					
Scale	1:1				
Drawing no.	3080				
Customer	JAGG				
Appr					
Drawn	082207 MB				
Contr					
Date/Sign					
Material					
Part no.					
Denomination					
Material					
Dimension					
ALL measurements refer to unprinted object					
Part no. 14 ISLM-14 3/8 PO C4					
Tolerances specified	150 2768-V				
Replaces					
Replaced by					
Connected drawings					
Scale	1:1				
Drawing no.	3080				
Customer	JAGG				
Appr					
Drawn	082207 MB				
Contr					
Date/Sign					
Material					
Part no.					
Denomination					
Material					
Dimension					
ALL measurements refer to unprinted object					
Part no. 14 ISLM-14 3/8 PO C4					
Tolerances specified	150 2768-V				
Replaces					
Replaced by					
Connected drawings					
Scale	1:1				
Drawing no.	3080				
Customer	JAGG				
Appr					
Drawn	082207 MB				
Contr					
Date/Sign					
Material					
Part no.					
Denomination					
Material					
Dimension					
ALL measurements refer to unprinted object					
Part no. 14 ISLM-14 3/8 PO C4					
Tolerances specified	150 2768-V				
Replaces					
Replaced by					
Connected drawings					
Scale	1:1				
Drawing no.	3080				
Customer	JAGG				
Appr					
Drawn	082207 MB				
Contr					
Date/Sign					
Material					
Part no.					
Denomination					
Material					
Dimension					
ALL measurements refer to unprinted object					
Part no. 14 ISLM-14 3/8 PO C4					
Tolerances specified	150 2768-V				
Replaces					
Replaced by					
Connected drawings					
Scale	1:1				
Drawing no.	3080				
Customer	JAGG				
Appr					
Drawn	082207 MB				
Contr					
Date/Sign					
Material					
Part no.					
Denomination					
Material					
Dimension					
ALL measurements refer to unprinted object					
Part no. 14 ISLM-14 3/8 PO C4					
Tolerances specified	150 2768-V				
Replaces					
Replaced by					
Connected drawings					
Scale	1:1				
Drawing no.	3080				
Customer	JAGG				
Appr					
Drawn	082207 MB				
Contr					
Date/Sign					
Material					
Part no.					
Denomination					
Material					
Dimension					
ALL measurements refer to unprinted object					
Part no. 14 ISLM-14 3/8 PO C4					
Tolerances specified	150 2768-V				
Replaces					
Replaced by					
Connected drawings					
Scale	1:1				
Drawing no.	3080				
Customer	JAGG				
Appr					
Drawn	082207 MB				
Contr					
Date/Sign					
Material					
Part no.					
Denomination					
Material					
Dimension					
ALL measurements refer to unprinted object					
Part no. 14 ISLM-14 3/8 PO C4					
Tolerances specified	150 2768-V				
Replaces					
Replaced by					
Connected drawings					
Scale	1:1				
Drawing no.	3080				
Customer	JAGG				
Appr					
Drawn	082207 MB				
Contr					
Date/Sign					
Material					
Part no.					
Denomination					
Material					
Dimension					
ALL measurements refer to unprinted object					
Part no. 14 ISLM-14 3/8 PO C4					
Tolerances specified	150 2768-V				
Replaces					
Replaced by					
Connected drawings					
Scale	1:1				
Drawing no.	3080				
Customer	JAGG				
Appr					
Drawn	082207 MB				
Contr					
Date/Sign					
Material					
Part no.					
Denomination					
Material					
Dimension					
ALL measurements refer to unprinted object					
Part no. 14 ISLM-14 3/8 PO C4					
Tolerances specified	150 2768-V				
Replaces					
Replaced by					
Connected drawings					
Scale	1:1				
Drawing no.	3080				
Customer	JAGG				
Appr					
Drawn	082207 MB				
Contr					
Date/Sign					
Material					
Part no.					
Denomination					
Material					
Dimension					
ALL measurements refer to unprinted object					
Part no. 14 ISLM-14 3/8 PO C4					
Tolerances specified	150 2768-V				
Replaces					
Replaced by					
Connected drawings					
Scale	1:1				
Drawing no.	3080				
Customer	JAGG				
Appr					
Drawn	082207 MB				
Contr					
Date/Sign					
Material					