



# Item No: 707-R Electric Ride-On

Installation & operation Manual



 **CAUTION:**

- This package contains small parts
- Adult assembly required
- Remove all plastic bags and package ties prior to giving to children
- Protective equipment recommended
- Not to be used in traffic
- Keep this instructions for future reference

 **WARNING**

**ADULT ASSEMBLY  
REQUIRED.**













**2023 Ford Motor Company.  are trademark(s) of Ford or its affiliates used under license.**

**Manufactured and distributed by Ningbo Prince Toys Co., Ltd. under license. The [FORD] trademark and related trademarks and designs are used with the permission of Ford Motor Company.**

## I.SPECIFICATION.

Suitable Ages	3-6 years
Product Dimensions	105x64x60 cm
Maximum Weight	30 kgs
Speed	3-5km/h
Motor	30W
Charger	12V1000mA
Battery	12V7AH
Remote Control	2.4G one to one function
Remote Control Batteries	2XAAA Size(not included)
Steering Wheel Batteries	2XAA Size(not included)
Operating Ambient Temperature	0-40°C

## II.Components List.

<b>1.Body 1pc</b> 	<b>2.Steering wheel 1pc</b> 	<b>3.Seat 1pc</b> 
<b>4.Bracket 1pc</b> 	<b>5.Windshield 1pc</b> 	<b>6.Rear mirror 1pair</b> 
<b>7.Wheel 4pcs</b> 	<b>8.Wheel cap 4pcs</b> 	<b>9.Rear support with wheel axle 1pc</b> 
<b>10.Tool 2pcs</b> 	<b>11.Charger 1pc</b> 	<b>12.Remote control 1pc</b> 



### III.Assembly Instructions.

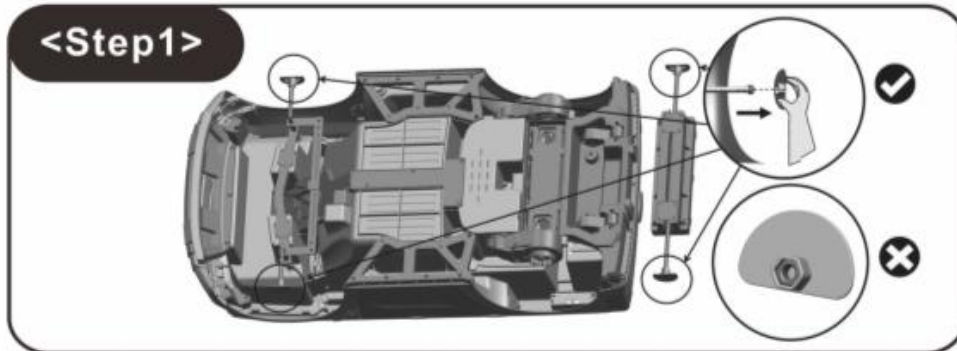

1.Take out the protect sleeves,make sure the nuts stay in the axle.

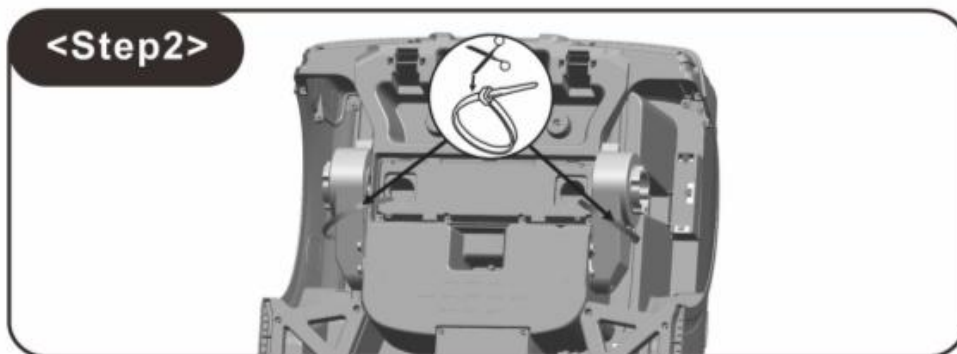

2.Turn over the body and find the gearbox,then cut the ties.

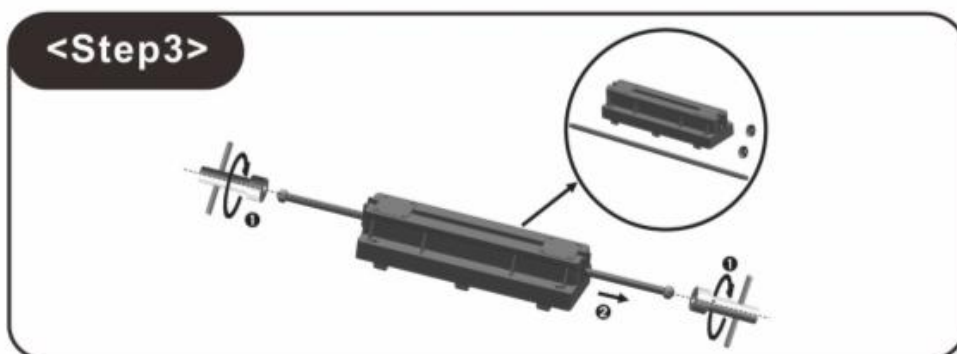

3.Release the two nuts with the tools provided,and pull the wheel axle out.

**<Step4>**

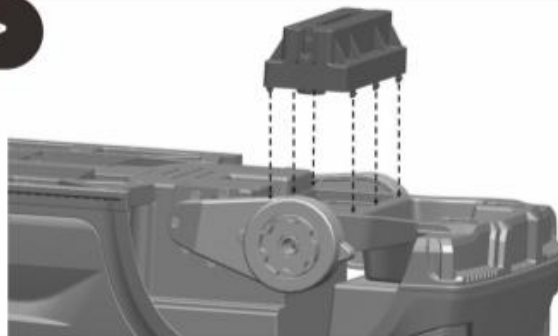

4. Place the rear support into the position of the body, make sure it is firmly fixed.

**<Step5>**



5. Rotate the gearbox and make the hole alignment, then insert the rear wheel axle.

**<Step6>**

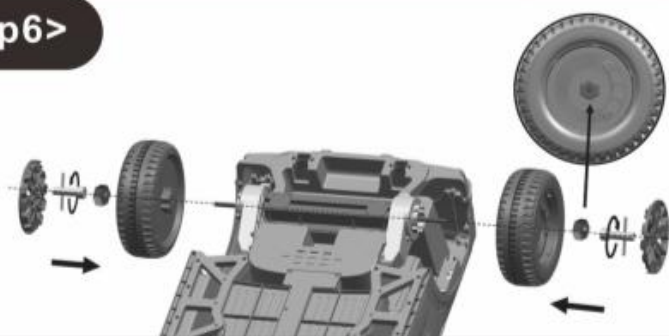

6. Insert the two wheels first and tighten with two nuts by the tools provided, then cover the wheel caps.

**<Step7>**



7. Release the two nuts with the tools provided.

**<Step8>**



8. Insert the two front wheels and tighten two nuts by the tools provided, cover the wheel caps.

**<Step9>**



9. Insert the windshield in the front of the body, make sure it is firmly fixed.



10. Press the button and insert the steering wheel.

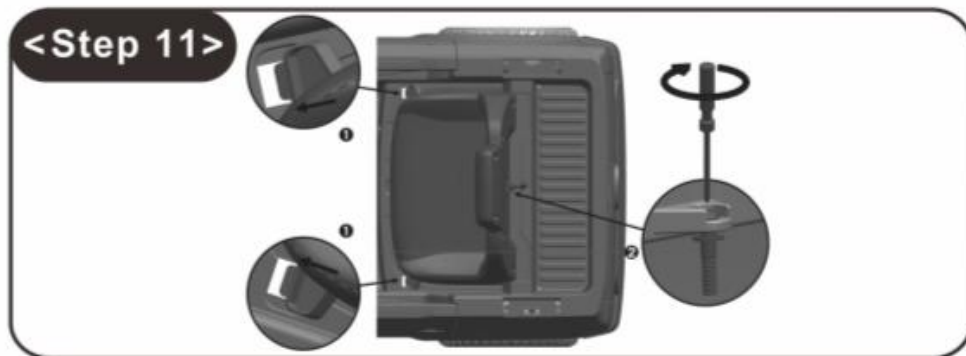

11. Place the front of the seat first, then close the rear of the seat, then close the rear of the seat, tighten by a screw with a screwdriver (not included).

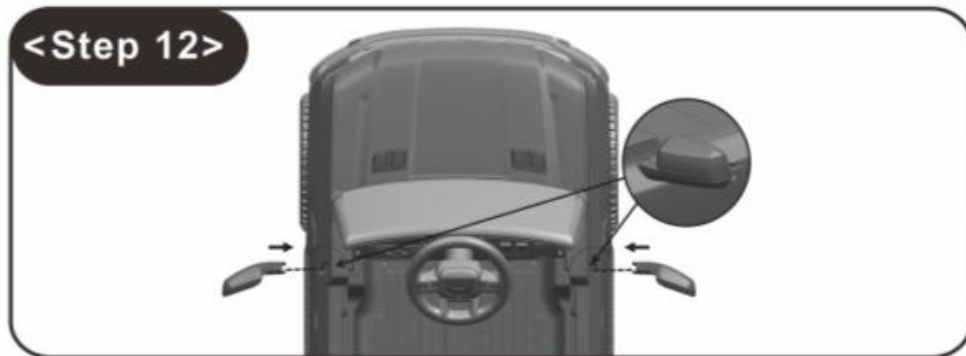

12. Place the two rear mirrors into the position of the body.

**<Step 13>**



**13.Place the bracket into the rear of the body.**

**<Step 14>**



**14.PULL OUT the key,let the battery power on.**

**IV.BATTERY CHANGE.**





## V.Function and Operation.

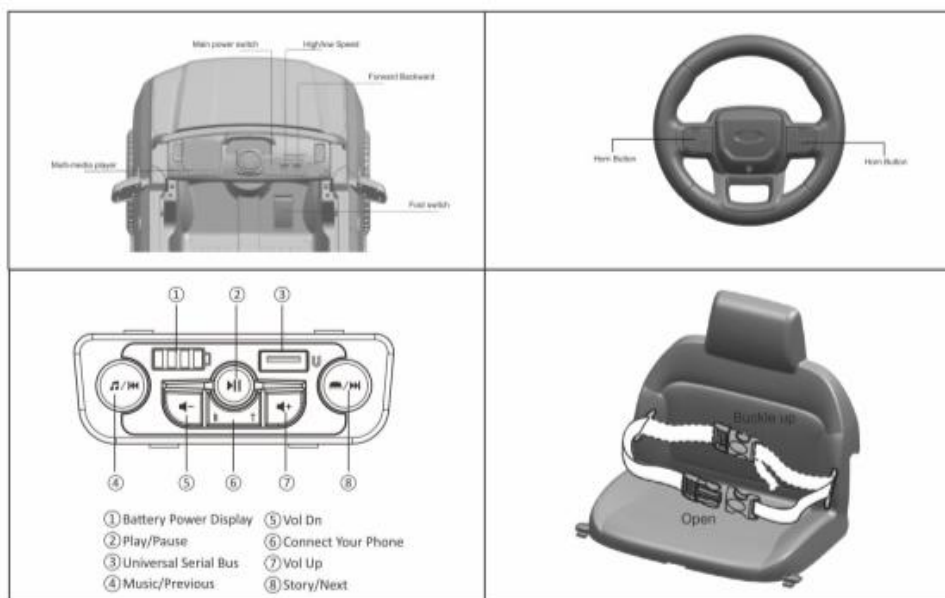

## VI.Charging the Drive Battery.

1. The charging socket is located at the lower part of the car seat.
2. Only battery and charger which are provided or recommended can be used only.
3. Please do not play with the charger and battery because they are not toys.
4. The battery charging operation is to be carried out only by adults.
5. The battery shall be fully charged before first use; the battery charging time shall be 9-10 hours and can not exceed 15 hours
6. It is normal for battery and charger to feel warm during charging.

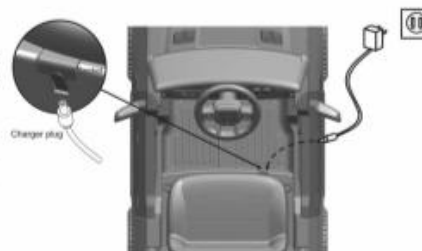

## VII.Simple Problem Diagnostic.

Defective conditions	Key points of inspection
1. The car can not be driven.	1) Ensure the power switch, all plugs of the control plate under the seat, and the battery terminal line are properly inserted.
	2) Ensure the over current protector, when the car is over loaded or blocked, the over current protector automatically disconnects the circuit to protect the motor and controlling IC board.
	3) Check whether the car has been stored for a long time and its battery is not charged on time.
	4) If the remote control cannot start the car, please check whether the remote control code-matching function is normally operated.
	5)Check whether the remote control battery power is low.
2. Music sound is distorted or silent	Check whether the battery has enough power, otherwise charge fully.

## **VIII.WARNING.**

### **1.Battery warning:**

- 1 )When storing the car for long period of time, charge the battery until full then turn off the power switch. The battery should be recharged once every other month, or may otherwise have a shorter life span and risk deteriorating.
- 2) When installing the battery, it is important that the positive and negative poles are correctly connected. Short circuiting of positive and negative poles may result in damaging the toy.

### **Battery warning:**

- 1) Product needs to be operated with two DC 1.5V AAA batteries (not included) and two DC1.5V AA batteries(not included).
- 2) Battery charging is recommended only to be done by adults.
- 3) Rechargeable batteries charging operation can be carried out only by adults.
- 4) Non-rechargeable batteries cannot be charged.
- 5) The rechargeable batteries can be charged only after being taken out from the remote control battery compartment.
- 6) Please do not mix different types of batteries or used batteries and new batteries.
- 7) If product will be stored for a long time, it is recommended to remove batteries from battery compartment.
- 8) Over used batteries should be removed from toy.

### **2. Product warning:**

- 1) There may be potential sharp edges, sharp points or small parts before the assembly of this product, and therefore this product shall be assembled by the adult.
- 2) To avoid suffocation, keep the plastic bag away from children. Dispose of all bags immediately.
- 3) Children shall use the car under adult guidance and supervision to prevent risk of injury.
- 4) The car is suitable for being driven on the flat ground and strictly prohibited to be driven in dangerous places such as public roads,slope and near swimming pool to prevent traffic and drowning accidents.
- 5) Please put on shoes and take protective measures before use,such as fastening the safety belt and putting on the helmet, gloves, knee pads,etc.
- 6) Not suitable for children under 36 months as parts may fall off when used improperly.
- 7) Regularly check whether the battery, charger, wire, plug, casing and other parts are damaged; if the damage occurs, please cease to use this product until it has been repaired.
- 8) This product is only allowed to be used by one child; the maximum load is 30kg, overload is not allowed.
- 9) Keep away from fire.
- 10) The product instructions shall be kept as they contain important information.

## IX. Remote Control Instructions.



Loosen the screw with a screwdriver, then insert two AAA batteries. Place the battery cover, then tighten with a screw.

- ① Forward/backward button
- ② Turn left/right button
- ③ Brake button
- ④ Speed change button
- ⑤ Frequency bind button

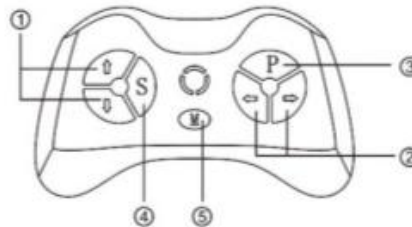

**Operation manual: For first time use, need to frequency bind.**

- Take out the remote control and install the battery.
- Hold the 'M' button for 2-4 seconds – the indicator will flash.
- Switch on the car, When the indicator light stays on, the frequency bind is successful.
- If the frequency bind failed (indicator keeps flashing), remove the battery and repeat steps 1-3.
- When the remote control has not been used for 10 seconds, the indicator will switch to power saving mode.
- Button Description:  $\Delta$  forward,  $\nabla$  backward,  $\triangleleft$  turn left,  $\triangleright$  turn rights, Speed P.  
Emergency brake, when pressed, the car will come to a stand still. Press again to release break.

### 3. WARNING:



## WARNING

Adult supervision required to reduce the risk of injury;  
Strictly forbidden to use on roadways, near motor vehicles, slopes or swimming pools and areas where there is water;  
Please wear shoes when operating vehicle;  
Can only be used by one person at a time;  
Keep away from children before assembled as there may be sharp edges points or small parts.  
Adult assembly required.  
A reminder that the toy should be used with caution since skill is required to avoid falls or Collisions causing injury to the user or third parties.



## WARNING

Do not mix alkaline battery, standard (carbon–zinc) battery or rechargeable (nickel–cadmium) battery.



## WARNING

Protective equipment should be worn. Not to be used in traffic.



## WARNING

This product is not suitable for children under 3 years of age due to its maximum speed.

### X. Care and Maintenance

- 1) Regularly wipe and clean it with a piece of cloth.
- 2) The rotating parts of the car should be checked regularly to determine whether any foreign matter obstructs the rotation and to keep lubricating state of normal operation.

**Manufacturer Contact Information:**  
**Ningbo Prince Toys Co.,Ltd**  
**E-MAIL:info@serviceprohelp.com**