

# INSTRUCTION MANUAL

MODEL: 1334-2LM

Edition:20231224535Z

Congratulations, you now have a new function sofa with massage.

Before enjoy the comfort chair, you have to put it together. This Assembly Guide will take you through the basic assembly process. To make sure your assembly goes smoothly, please follow the assembly instructions, **and especially the important safety information.**

Also, while it is possible to assemble the chair on your own, **having a second person to help you makes it even easier.**

Before you begin, please check if there are any missing parts from the package. Should there be any issues, please don't hesitate to drop us an email and we'll help you out ASAP.

MANUFACTURER: THE JIUAND FENG TECHNOLOGY LIMITED  
MANUFACTURER ADDRESS: RM F 6/F MEGA  
WANG KWONG ROAD KOWLOON BAY KL  
Email: [info@serviceprohelp.com](mailto:info@serviceprohelp.com)

# PACKAGE LIST

02

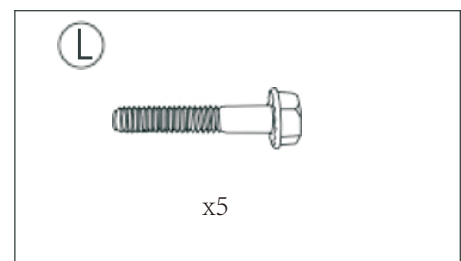
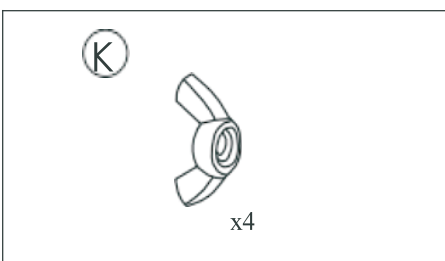
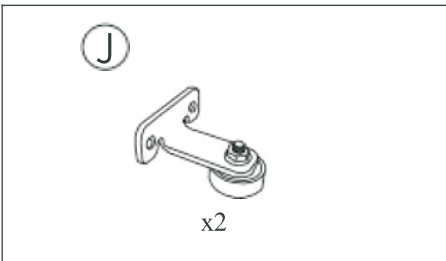
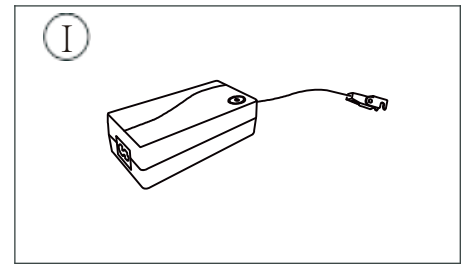
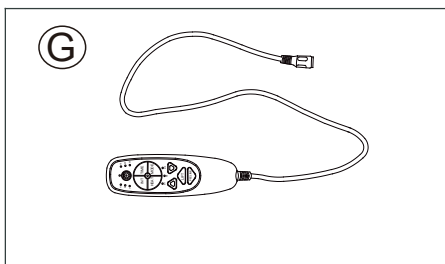
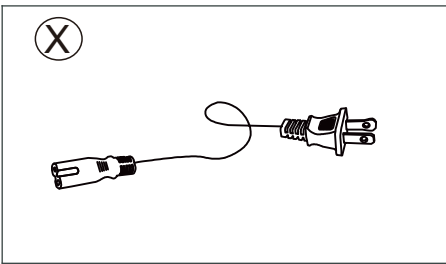
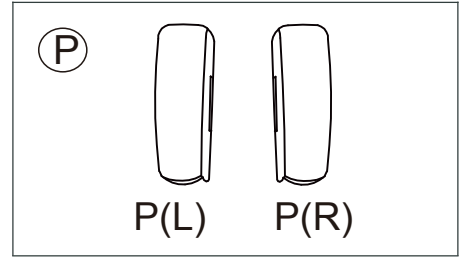
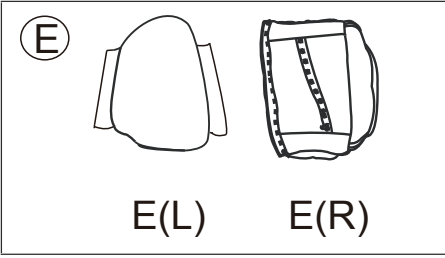
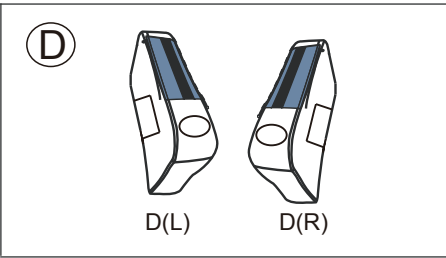
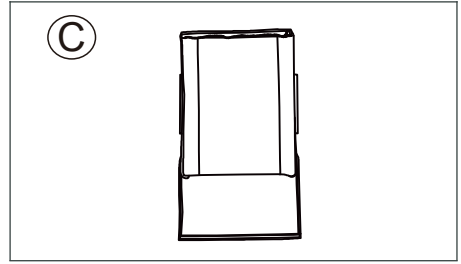
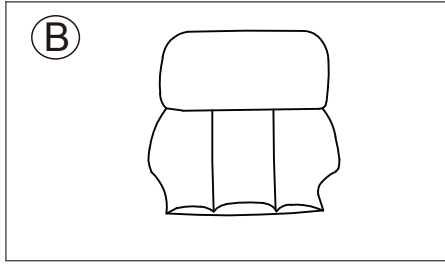
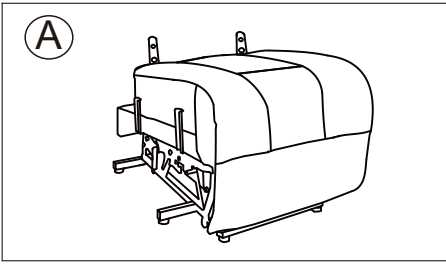

# ASSEMBLY INSTRUCTION

03

Please zip up both sides of the arm cushion

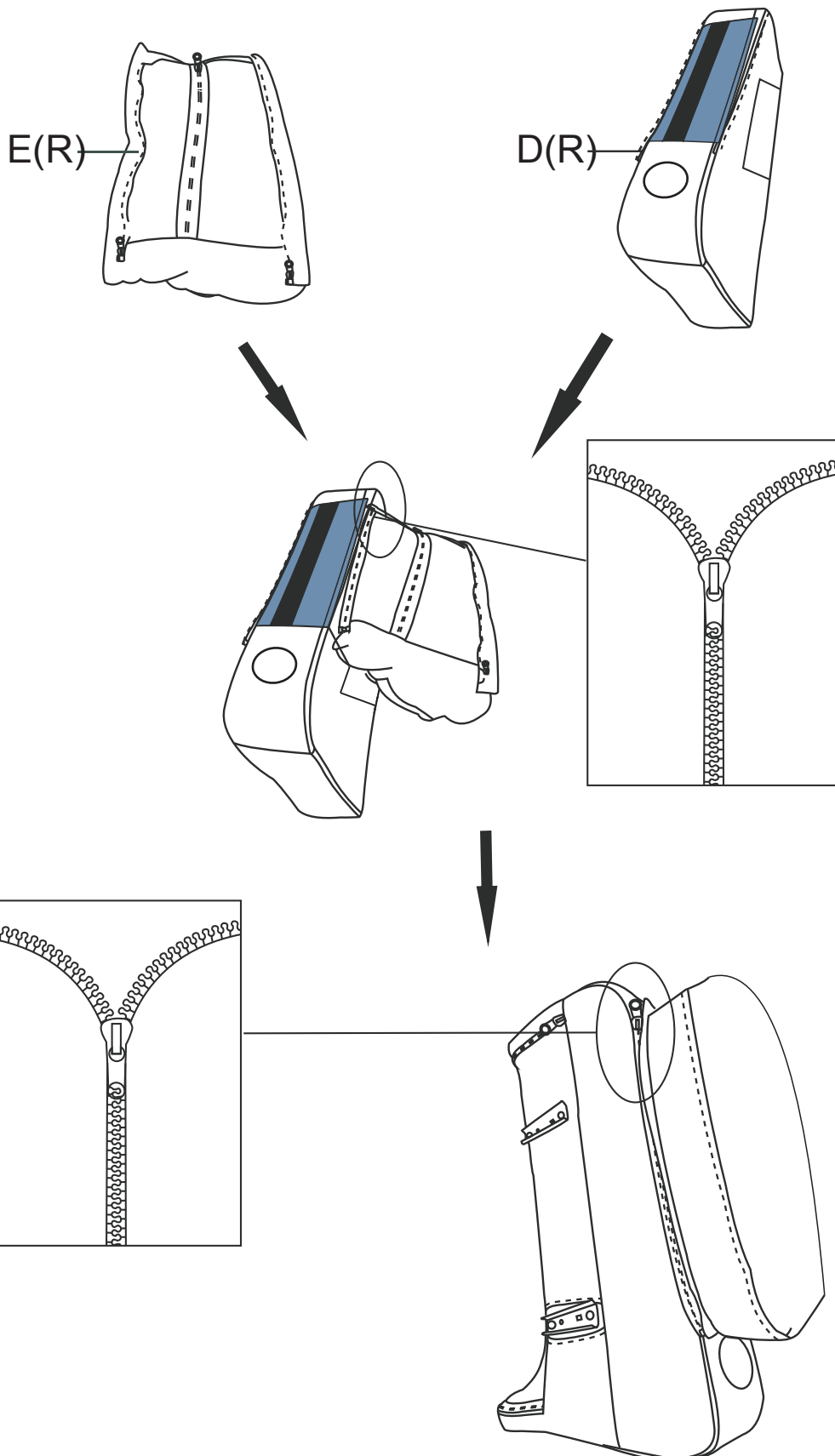

# ASSEMBLY INSTRUCTION

04

STEP 1: Turn the screw L through the support frame K, seat cushion frame successively, and the lock it with the nut J and the screw L

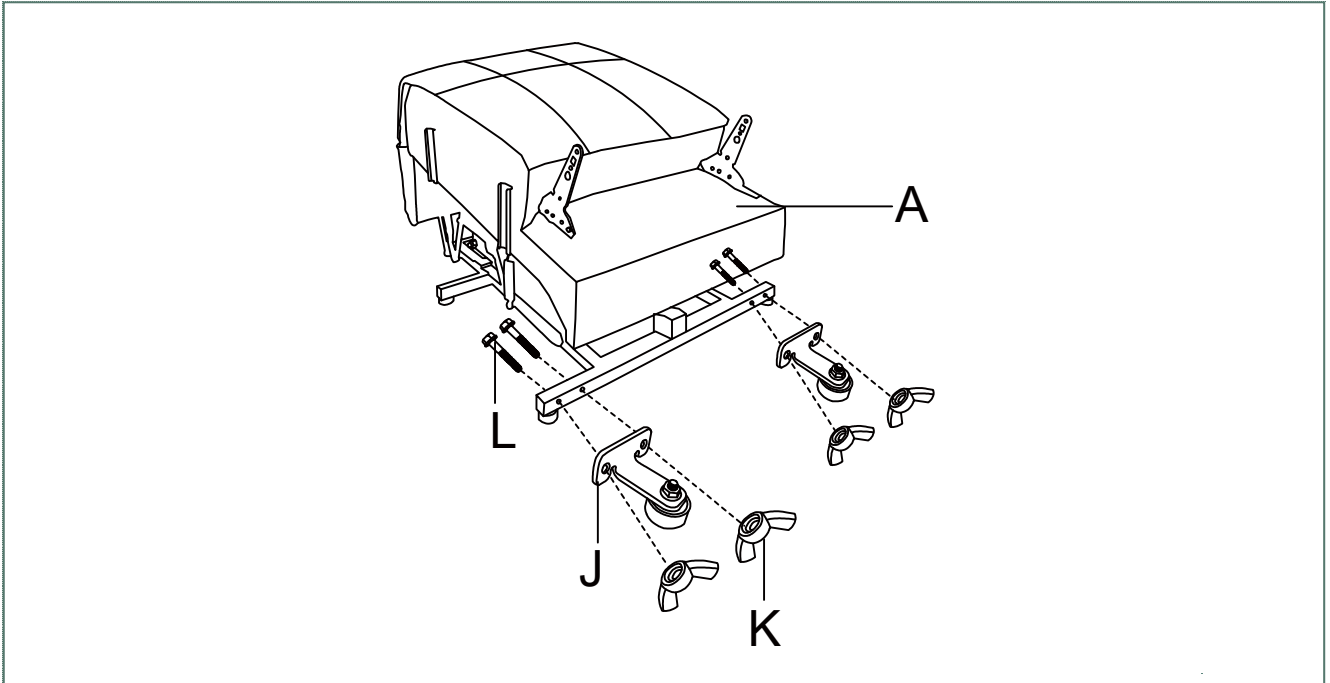

STEP 2: Insert arms so that they can fit into the seat, you will hear a “click” when they are engaged.

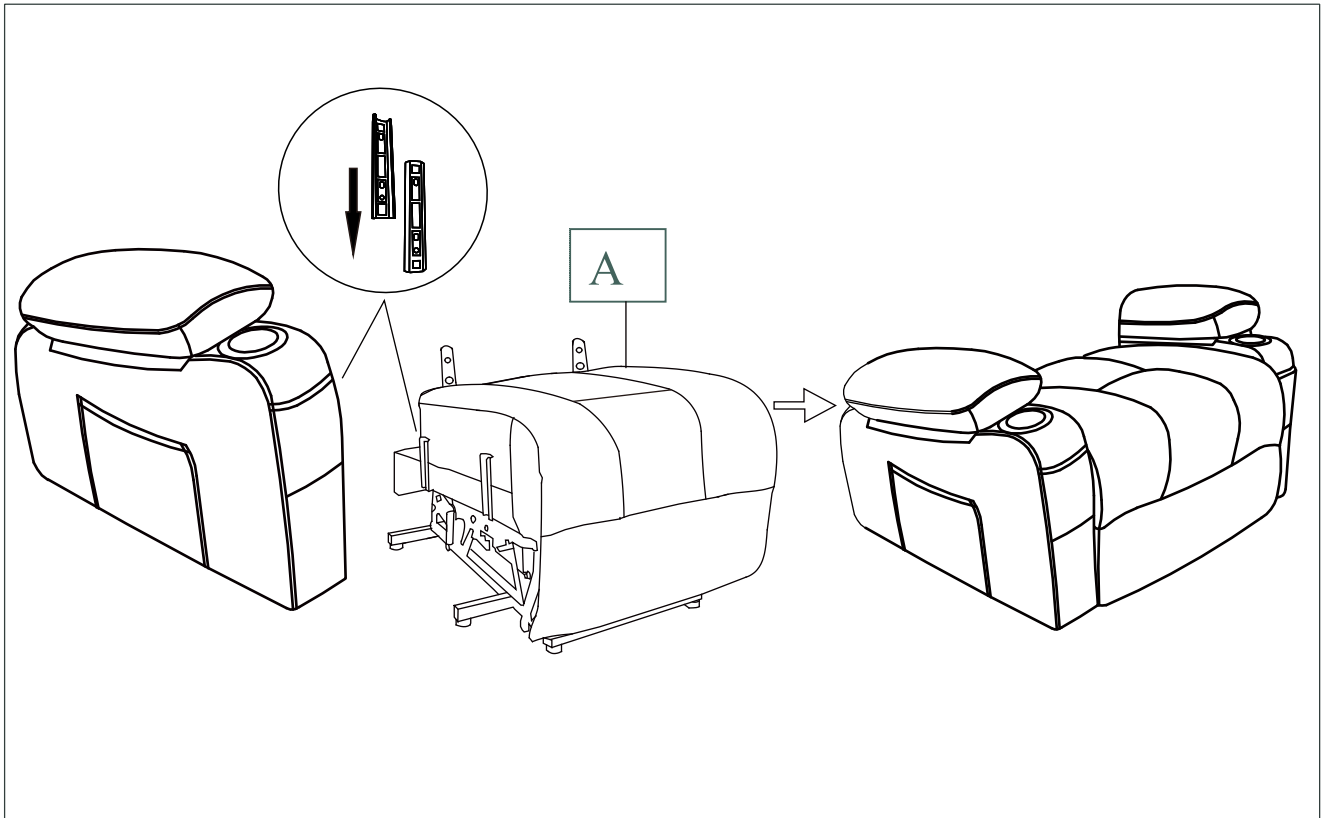

# ASSEMBLY INSTRUCTION

05

STEP 3: Zip up the Back B to the Backrest C, then connect the Back B and Backrest C with velcro.

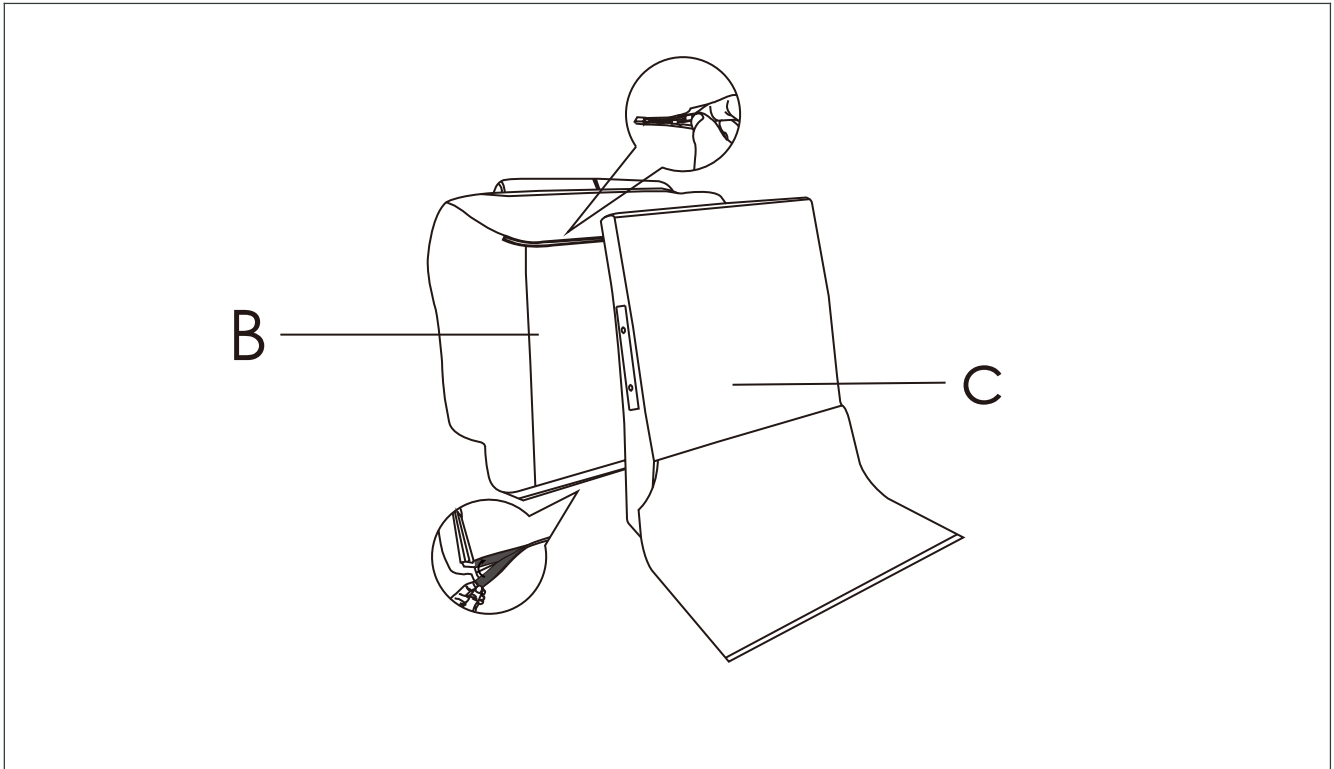

STEP 4: Insert the back ear P so that it can be installed into the back side. When they engage, you will hear a "click" sound.

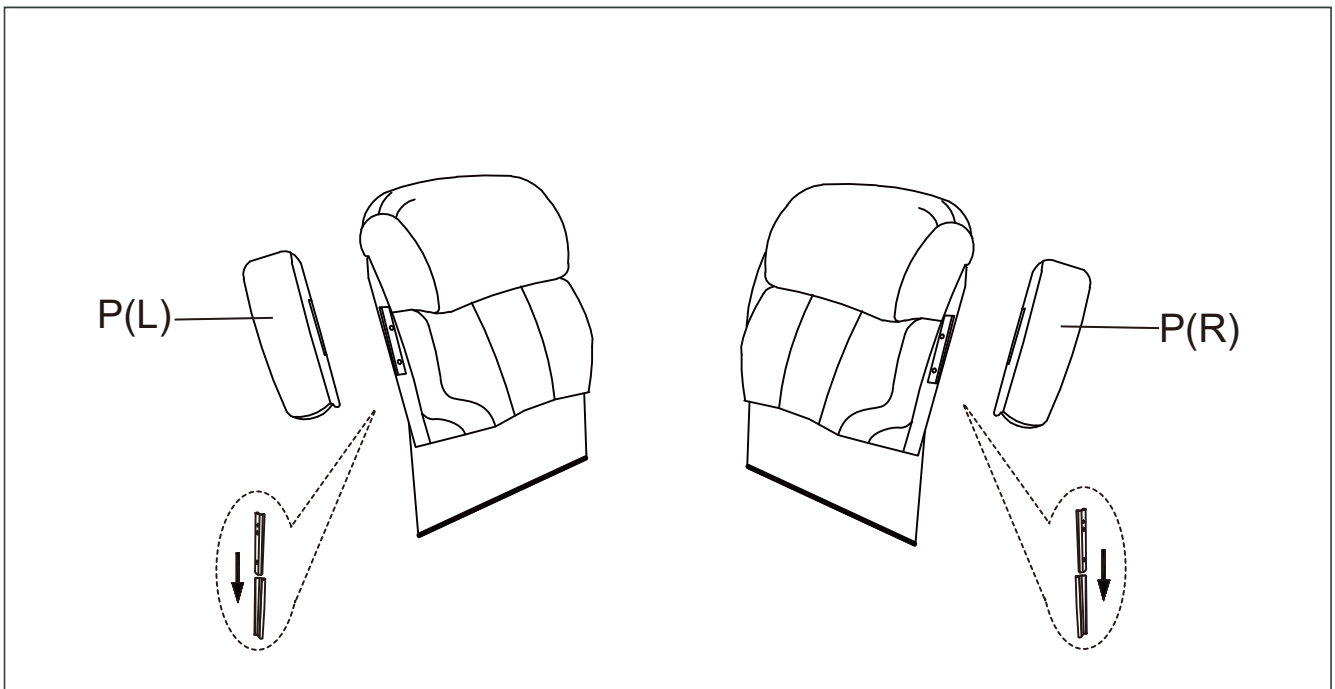

# ASSEMBLY INSTRUCTION

06

STEP 5: 1.Plug the back pad into the seat frame.

2.Connect the bigger round white cable with the bigger round white cable.

3.Link the red wires with the red, white wires and the white wires.

4.Connect the Massager remote G with the round black connector behind the seat back.

5.Insert the power adapter " I " into the cable behind the seat back.

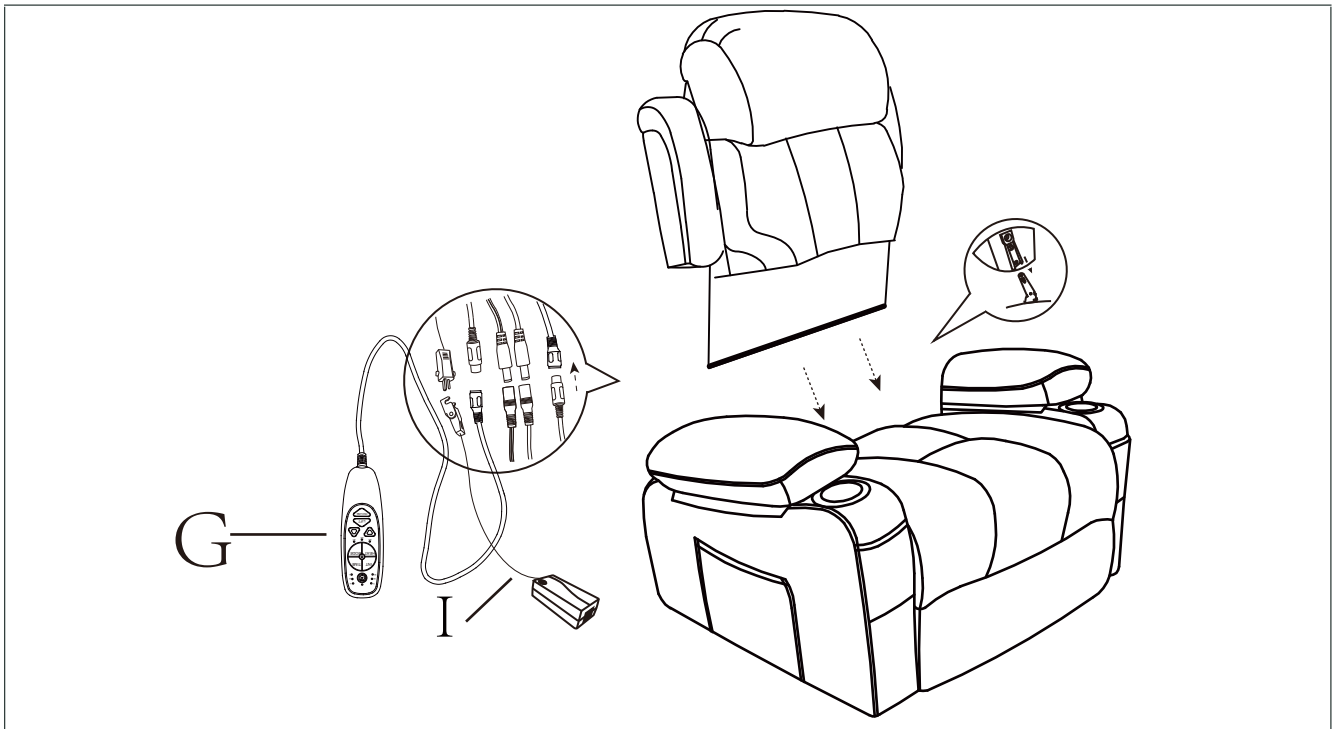

STEP 6: Connect the adapt X into I, then connect the power cord to the charging socket.

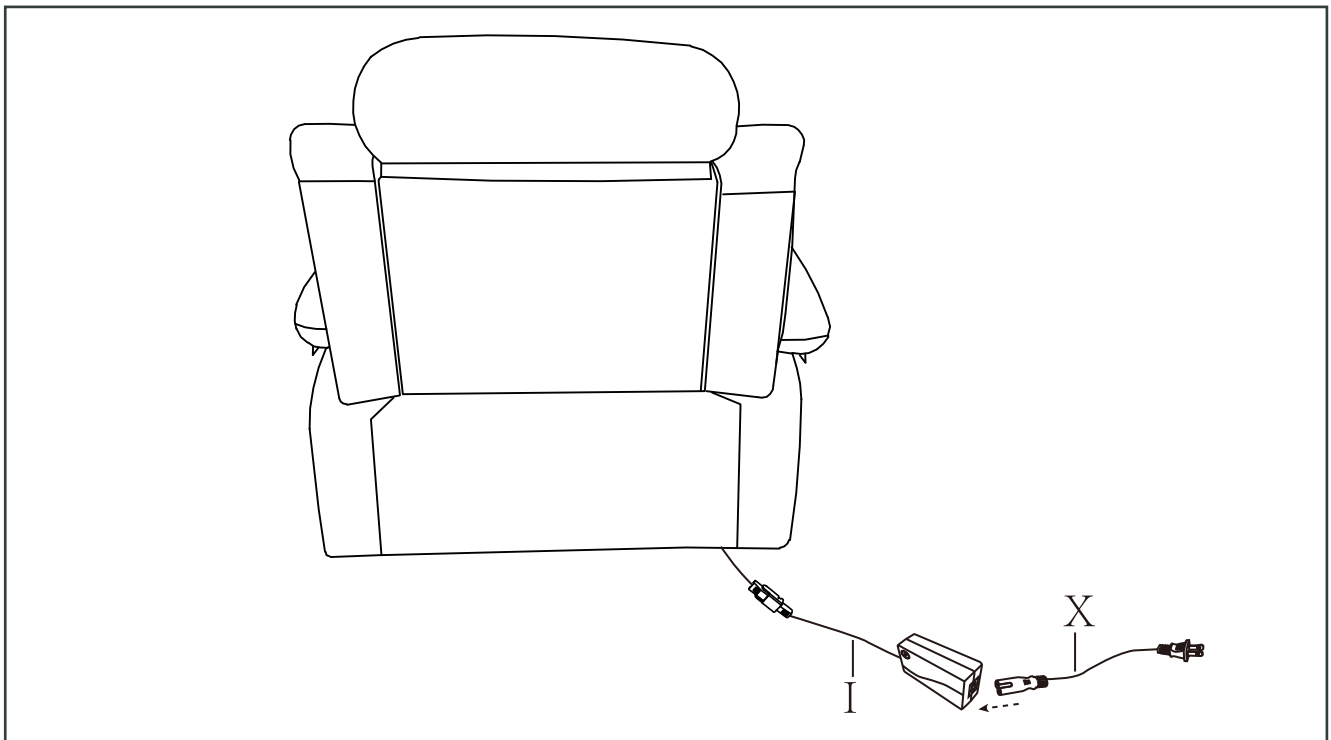

*Congratulations! You've assembled  
Your sofa!*

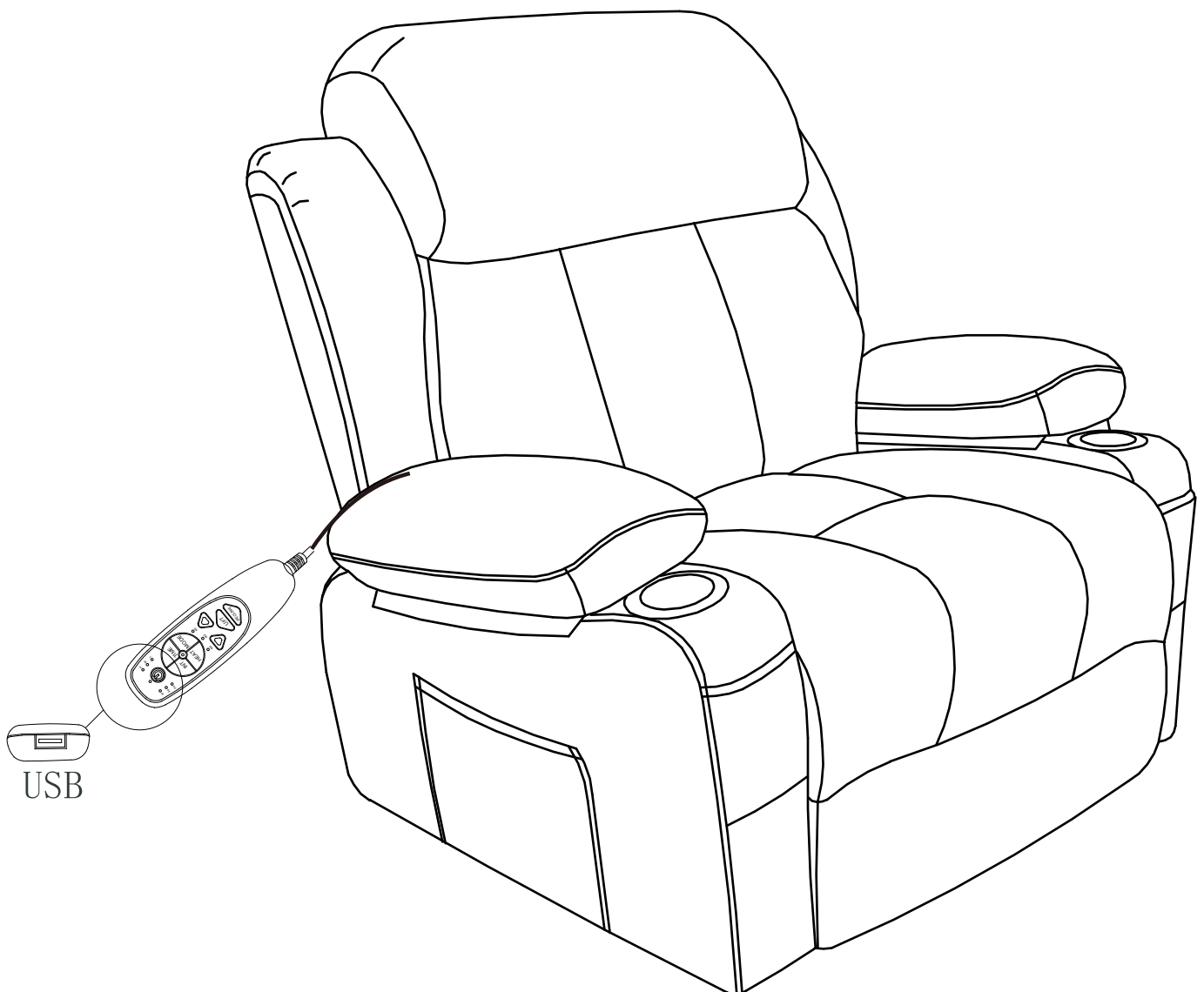

Note: Since the backrest is packed in compression, after the product is installed, you need to tap and adjust the backrest which can help restore fullness. After two days, you will get a Overstuffed Recliners as picture shows.



## OPERATING INSTRUCTION

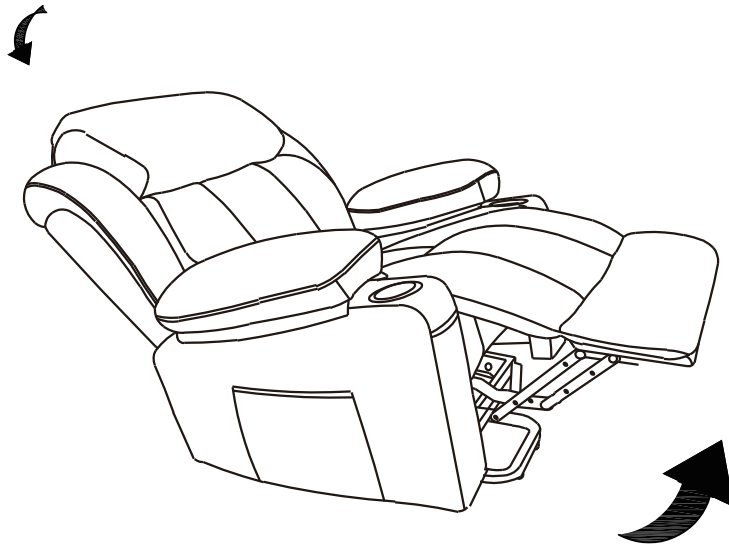

Press the lie down button to lie down on the sofa

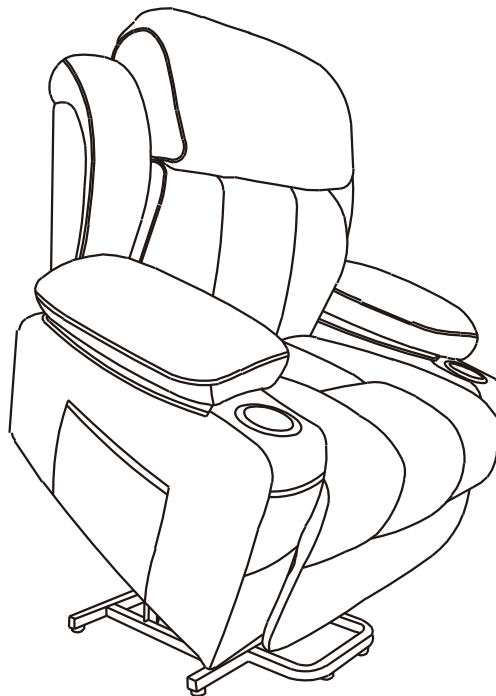

Press the raise button to raise the sofa

## OPERATING INSTRUCTION

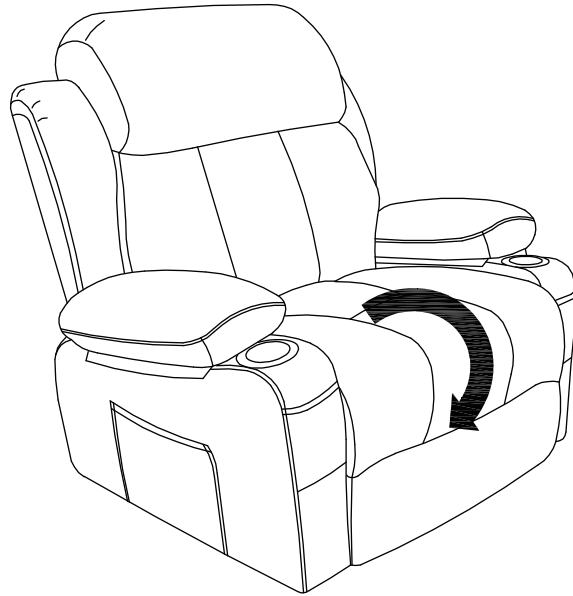

Press the descent button to retract the sofa legs

**READ ALL INSTRUCTIONS  
BEFORE USING THE ITEM**

## **REMOTE CONTROL** **Function of remote**

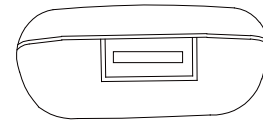

**USB**

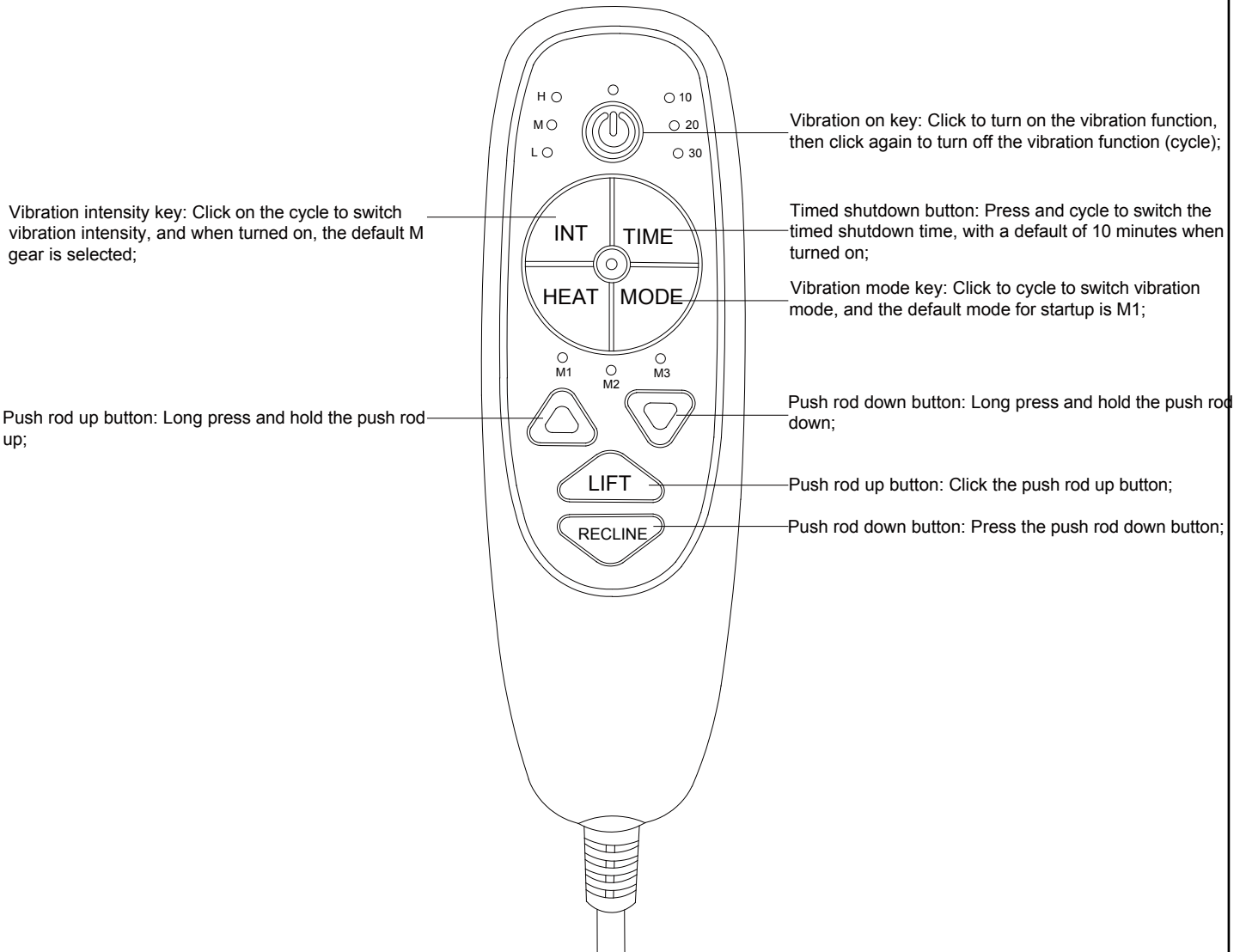

## I 、 Specifications of power adapter

Insert the adapter socket into the socket on the back of the massage chair, and then insert the adapter into the wall socket. Power adapter specifications: Input: AC 100-240V, 50/60HZ 1.5A; Output: DC29V, 2.0A.

## II 、 Product features

- 1、 4 parts 8 motor vibration
- 2、 1-way electric push rod
- 3、 1 heating plate
- 4、 Supports USB charging 5V 2.0A
- 5、 3-segment timed shutdown duration selection
- 6、 Selection of 3rd gear vibration intensity
- 7、 3 vibration modes selection
- 8、 Default scheduled shutdown time 10Min

## III、 Function details

- 1、 Vibration on key: Click to turn on the vibration function, then click again to turn off the vibration function (cycle);
- 2、 Vibration intensity key: Click on the cycle to switch vibration intensity, and when turned on, the default M gear is selected;
- 3、 Timed shutdown button: Press and cycle to switch the timed shutdown time. The default time for powering on is 10 minutes;
- 4、 Vibration mode key: Click to cycle to switch vibration mode, and the default mode for startup is M1;
- 5、 Push rod up button: Long press and hold the push rod up;
- 6、 Push rod down button: Long press and hold the push rod down;
- 7、 Push rod up button: Click the push rod up button;
- 8、 Push rod down button: Press the push rod down button;

## Warnings

- Sit down in the chair gently. To avoid tipping over, do not throw yourself into the chair. Move the chair into the reclining position slowly, making sure that no children or pets are in close proximity. Do not allow children to play on or around the chair, particularly when it is in an open position.
- Close the recliner completely before getting out of it.
- Never sit on the footrest when it is open, even if it is a child.
- To eliminate the risk of tipping over, do not sit on the arms or footrest of the chair.
- This chair is designed to be used by 1 adult at a time.
- Please forbid people with the following ailments from using this sofa: Those people with severe symptoms of heart disease, high blood pressure, cerebral thrombosis and others who are sensitive to heat or completely insensitive to heat, those with brittle bones or have issues with waist support pregnant women, children and others where it has been determined they are not suitable to use this product under the guidance of doctors.
- To fully recline the sofa, ensure the sofa well, you need to put the sofa at least 19 inches away from the wall or any other obstacle.
- Product cannot touch water, fire, etc. Product can also not come in contact with sharp objects (knives, nails, etc.)

## Maintenance Manual Instructions

- To avoid dropping, you should carry the sofa carefully.
- If you find dirt and or stains on the chair, spray the sofa with a sofa specific cleaner then use a sponge or cloth to wipe the dirt away. Do not use water, soapy water or cleaner with waxed wooden areas. Take care to wipe the sofa carefully and gently.
- Do not put the sofa in an area with direct sunlight and do not put the sofa directly in front of an air conditioner, this will fade the upholstery and make it brittle.

## **How to Disassemble**

Please find a strong tool to prod the small piece of metal grooves, then the backrest will be pulled out. The tool is not included.