

# Installation Manual



## ⚠ WARNING! ⚠

This equipment is similar to other gate or door equipment and meets or exceeds Underwriters Laboratory Standard 325 (UL 325). However, gate equipment has hazards associated with its use and therefore by installing this product the installer and user accept full responsibility for following and noting the installation and safety instructions. Failure to follow installation and safety instructions can result in hazards developing due to improper assembly. You agree to properly install this product and that if you fail to do so GTO Access Systems, LLC, shall in no event be liable for direct, indirect, incidental, special or consequential damages or loss of profits whether based in contract tort or any other legal theory during the course of the warranty or at any time thereafter. The installer and/or user agree to assume responsibility for all liability and use of this product releasing GTO Access Systems, LLC, from any and all liability. If you are not in agreement with this disclaimer or do not feel capable of properly following all installation and safety instructions you may return this product for full replacement value.

**READ ALL INSTRUCTIONS CAREFULLY AND COMPLETELY** before attempting to install and use this automatic gate opener. This gate opener produces a high level of force. Stay clear of the unit while it is operating and exercise caution at all times.

All automatic gate openers are intended for use on **vehicular gates only**.



This product meets and exceeds the requirements of UL 325, the standard which regulates gate operator safety, by Underwriters Laboratories Inc.



For more information on Mighty Mule's full line of Automatic Gate Openers and Access Controls visit our website at [www.mightymule.com](http://www.mightymule.com)

**GTO Sales:** 800-543-4283 • Fax 850-575-8912

**GTO Technical Service** 800-453-1236

For 24 hour/day, 7 day/week Technical Service visit <http://support.gtoinc.com>

For more information on Mighty Mule's full line of Automatic Gate Openers and Access Controls visit [www.mightymule.com](http://www.mightymule.com)

# U.L. Gate Operator Classifications

Residential Vehicular Gate Operator—Class I: A vehicular gate operator (or system) intended for use in a home of one-to-four single family dwelling, or a garage or parking area associated therewith.

Commercial/General Access Vehicular Gate Operator—Class II: A vehicular gate operator (or system) intended for use in a commercial location or building such as a multifamily housing unit (five or more single family units), hotel, garages, retail store, or other building servicing the general public.

Industrial/Limited Access Vehicular Gate Operator—Class III: A vehicular gate operator (or system) intended for use in an industrial location or building such as a factory or loading dock area or other locations not intended to service the general public.

Restricted Access Vehicular Gate Operator—Class IV: A vehicular gate operator (or system) intended for use in a guarded industrial location or building such as an airport security area or other restricted access locations not servicing the general public, in which unauthorized access is prevented via supervision by security personnel.

## Product Usage

The GTO Gate Operator meets all of the safety requirements of a Class I Residential Vehicular Gate Operator and is intended for use solely with **vehicular swing gates in single-family residential applications.**

The GTO Gate Operator system certified to be in compliance with the following safety standards (current edition as of publication date):



Product in compliance with the latest UL-325 and UL-991 safety standards by ETL. Product in compliance with CAN/CSA-C22.2 No. 247-92.



Product in compliance with IEC 60335-2-103:2003 and IEC 60335-1:2004, including A1:2004.

### Converting Metric Units to English Equivalents

When You Know	Multiply By	To Find	Symbol
centimeters	0.3937	inches	in. (or ")
meters	3.2808	feet	ft. (or')
kilograms	2.2046	pounds	lb. (or #)

### Converting English Units to Metric Equivalents

When You Know	Multiply By	To Find	Symbol
inches	2.5400	centimeters	cm
feet	0.3048	meters	m
pounds	0.4535	kilograms	kg

### Converting Temperature

deg. Celsius	$(^{\circ}\text{C} \times 1.8) + 32$	deg. Fahrenheit	$^{\circ}\text{F}$
deg. Fahrenheit	$(^{\circ}\text{F} - 32) \div 1.8$	deg. Celsius	$^{\circ}\text{C}$

## FOR YOUR RECORDS

Please record the following information product serial number (located on right side of control box), be sure to **keep all receipts for proof of purchase.** Refer to this information when calling GTO for service or assistance with your automatic gate opener.

Serial Number: \_\_\_\_\_ Date of Purchase: \_\_\_\_\_

Place of Purchase: \_\_\_\_\_

# Table of Contents

Gate Opener Class Categories .....	inside cover
Units and Standards Conversion Chart .....	inside cover
<b>PLEASE READ THIS FIRST!</b> .....	<b>page iii</b>
<b>Important Safety Instructions</b> .....	<b>page 1</b>
Disconnecting the Opener .....	page 1
Important Safety Instructions for the Consumer .....	page 2
Secondary Means of Protection Against Entrapment .....	page 5
Required Safety Precautions for Gates .....	page 6
Warning Signs and Labels .....	page 7
<b>Installation</b> .....	<b>page 8</b>
Parts List .....	page 8
Technical Specifications .....	page 10
Installation Overview .....	page 11
Installation of the Mounting Hardware .....	page 12
Mounting the First Opener .....	page 16
Installing the Second Opener .....	page 16
Installation of the Closed Position Stops .....	page 17
Mounting the Control Box .....	page 19
Connecting the Opener Power Cables .....	page 20
<b>Powering the System</b> .....	<b>page 21</b>
Solar Chart .....	page 21
Connecting the Transformer .....	page 23
<b>Control Board Settings</b> .....	<b>page 24</b>
Setting Closed Position Limits .....	page 25
<b>Setting Your Personal Transmitter Code</b> .....	<b>page 26</b>
Obstruction Sensitivity .....	page 27
<b>Installing the Receiver</b> .....	<b>page 27</b>
<b>Connecting Accessories</b> .....	<b>page 28</b>
<b>Wiring Accessories</b> .....	<b>page 29</b>
<b>Push to Open Installation</b> .....	<b>page 30</b>
Setting Open Position Limits .....	page 31
<b>Troubleshooting Guide</b> .....	<b>page 33</b>
<b>Repair Service</b> .....	<b>page 35</b>
<b>Column Installation Information</b> .....	<b>page 36</b>
<b>Accessory Catalog</b> .....	<b>page 37</b>

**KEEP THESE INSTRUCTIONS FOR FUTURE REFERENCE**

---

# PLEASE READ THIS FIRST!

Thank you for purchasing a GTO ACCESS SYSTEMS gate opener. When correctly installed and properly used, your gate operator will give you many years of reliable service. Please read the following information to ensure you have the correct system for your particular needs. This manual will enable you to properly install your Automatic Gate Operator.

The gate operator is designed for installation on a **pull-to-open** single leaf gate. By purchasing two accessory brackets [347IH], the gate operators can accommodate **push-to-open** gates (gates that open out from the property). The gates must not exceed 18 feet in length nor weigh more than 850 pounds per leaf (please see Technical Specifications on page 10). The gate operator can be used on vinyl, aluminum, chain link, farm tube, and wrought iron gates. Use on solid (wood) gates is not recommended. Solid surface gates have a high resistance to the wind. If the wind is strong enough, the operator will obstruct, stop, and blow fuses.

The gate operator accommodates extra transmitters, digital keypads, solar panels, push buttons, automatic gate locks, and other access control products. These optional accessories are shown in the back of this manual.

The gate operator features adjustable stall force. This safety feature makes the gate stop and reverse direction within two seconds when it comes in contact with an obstruction. The “MIN” setting means the gate will exert the minimum force on an obstruction before it stops and reverses direction.

The gate operator also has an adjustable auto-close feature. It can be set to remain open from 3 to 120 seconds before automatically closing. Pressing the transmitter button at any time after the gate fully opens will cause it to close immediately. “OFF” is the factory setting; meaning the gate will stay open until you press the transmitter button (or keypad, etc.) again.

Please call GTO at (800) 543-4283 for more information about our GTO ACCESS SYSTEMS professional line of gate operators and accessories.

## **BEFORE YOU BEGIN TO INSTALL YOUR AUTOMATIC GATE OPERATOR:**

**Read these instructions carefully and completely to become familiar with all parts and installation steps. You must read the installation manual for detailed instructions on gate operator safety and proper use of the gate operator.**



**24/7 Troubleshooting Wizard: <http://support.gtoinc.com>**

# ⚠ IMPORTANT SAFETY INSTRUCTIONS ⚠

Because automatic gate openers produce high levels of force, consumers need to know the potential hazards associated with improperly designed, installed, and maintained automated gate opener systems. **Keep in mind that the gate opener is just one component of the total gate operating system.** Each component must work in unison to provide the consumer with convenience, security, and safety.

This manual contains various safety precautions and warnings for the consumer. Because there are many possible applications of the gate opener, the safety precautions and warnings contained in this manual cannot be completely exhaustive in nature. They do, however, provide an overview of the safe design, installation, and use of this product. **CAREFULLY READ AND FOLLOW ALL SAFETY PRECAUTIONS, WARNINGS, AND INSTALLATION INSTRUCTIONS TO ENSURE THE SAFE SYSTEM DESIGN, INSTALLATION, AND USE OF THIS PRODUCT.**

Precautions and warnings in this manual are identified with this  warning symbol. The symbol identifies conditions that can result in damage to the opener or its components, serious injury, or death.

Because GTO automatic gate openers are *only part of the total gate operating system*, it is the responsibility of the consumer to ensure that the total system is safe for its intended use.

## To Manually Open and Close the Gate, Follow the Procedure Below:

 **CAUTION:** The gate will move freely and uncontrolled when the gate opener is removed from the gate. **ONLY** disconnect the opener when the control box power switch is OFF and the gate is NOT moving.

### Disconnecting the Opener

1. Turn control box power switch OFF.
2. Remove hairpin clip, clevis pin, and bushing from either the front or rear mounting point.
3. Remove the opener from the mount.

*The gate can be opened and closed manually when the opener is disconnected.*

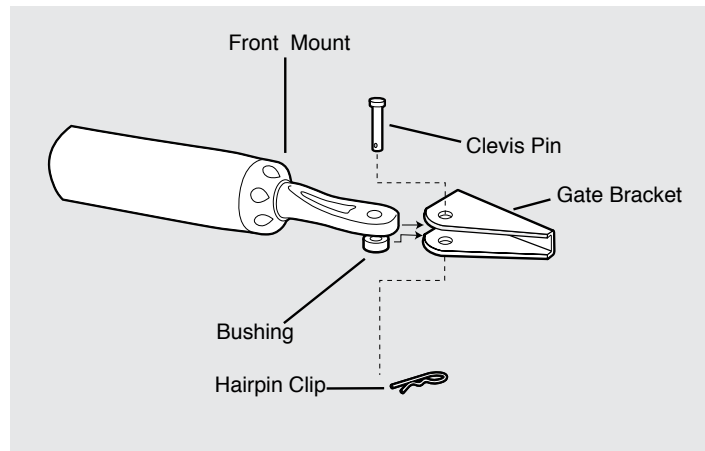

**NOTE:** Substitute a included **Pin Lock** for the clevis pin on the front mount of each gate opener to prevent unauthorized removal of the opener from the gate.

# ⚠ IMPORTANT SAFETY INSTRUCTIONS ⚠

## For The Consumer

### WARNING: To reduce the risk of injury or death:

1. **READ AND FOLLOW ALL INSTRUCTIONS.** Failure to meet the requirements set forth in the instruction manual could cause severe injury or death, for which the manufacturer cannot be held responsible.
2. When designing a system that will be entered from a highway or main thoroughfare, make sure the system is placed far enough from the road to prevent traffic congestion.
3. The gate must be installed in a location that provides adequate clearance between it and adjacent structures when opening and closing to reduce the risk of entrapment. Swinging gates **must not** open into public access areas.
4. The gate and gate opener installation **must comply with any applicable local codes.**

#### I. Before Installation

1. Verify this dual opener is proper for the type and size of gate, its frequency of use and the proper class rating.
2. Make sure the dual gate has been properly installed and swings freely in both directions. Repair or replace all worn or damaged gate hardware prior to installation. A freely moving gate will require less force to operate and will enhance the performance of the opener and safety devices used with the system. (*see page 11*)
3. Review the operation of the system to become familiar with its safety features. Understand how to disconnect the opener for manual gate operation (*see page 1*).
4. This gate opener is intended for **vehicular gates ONLY**. A separate entrance or gate must be installed for pedestrian use (*see page 6*).
5. Always keep people and objects away from the gate and its area of travel. **NO ONE SHOULD CROSS THE PATH OF A MOVING GATE.**
6. Pay close attention to the diagram below and be aware of these areas at all times.

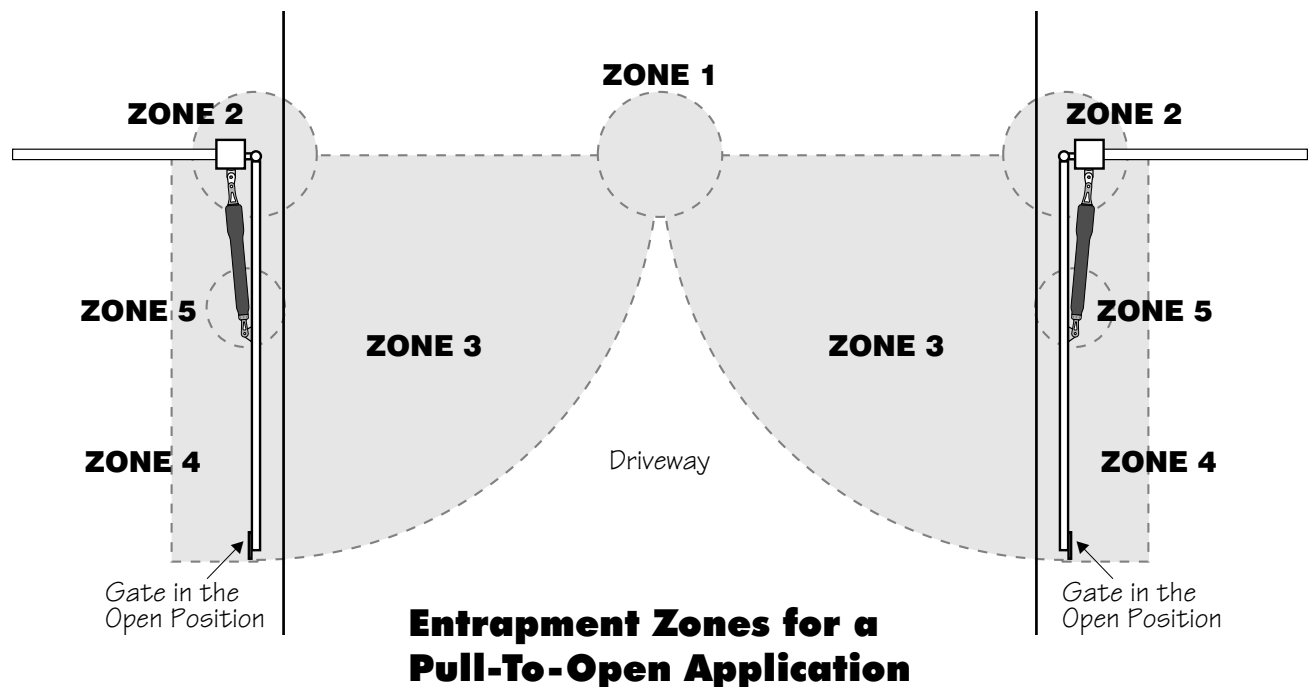

# ⚠ IMPORTANT SAFETY INSTRUCTIONS ⚠

Entrapment Zones for a proper Pull-To-Open installation:

- Zone 1 – leading edge of the gate and the fence post.
- Zone 2 – between the gate and the gate post.
- Zone 3 – the path of the gate.
- Zone 4 – the space between the gate in the open position and any object such as a wall, fence, tree, etc.
- Zone 5 – pinch points between the opener and gate.

## II. During Installation

1. Install the gate opener on the inside of the property and fence line. **DO NOT** install an opener on the outside of the gate where the public has access to it.
2. Be careful with moving parts and avoid close proximity to areas where fingers or hands could be pinched.
3. Devices such as contact sensors (safety edges) and non contact sensors (photo beams) provide additional protection against entrapment.
4. If push buttons or key switches are installed, they should be within sight of the gate, yet located at least 10 feet from any moving part of the gate (see diagram below). **Never install any control device where a user will be tempted to reach through the gate to activate the gate opener.**
5. Do not activate your gate opener unless you can see it and can determine that its area of travel is clear of people, pets, or other obstructions. Watch the gate through its entire movement.
6. Secure outdoor or easily accessed gate opener controls in order to prohibit unauthorized use of the gate.

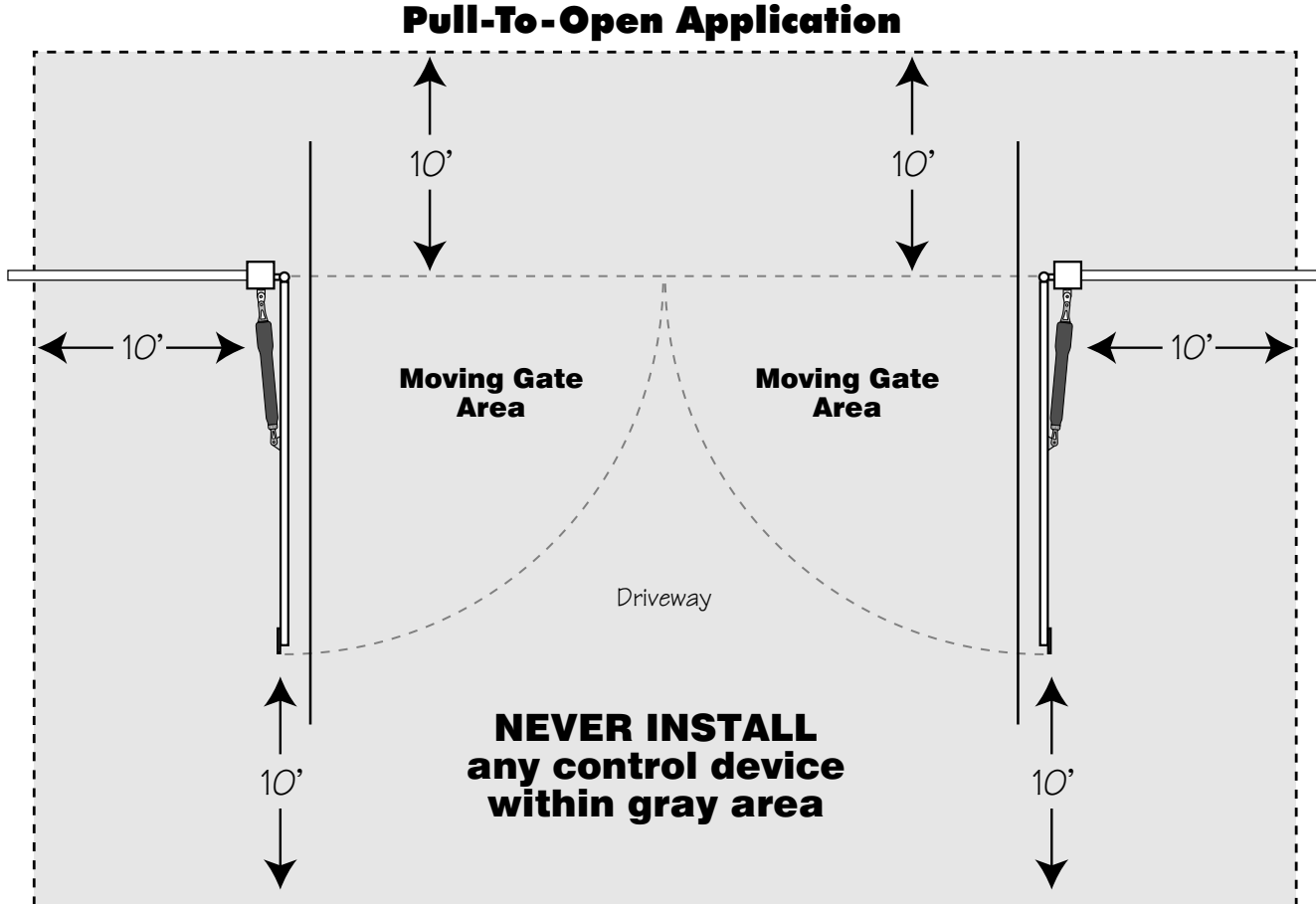

# **IMPORTANT SAFETY INSTRUCTIONS**

## III. After Installation

1. Attach the **warning signs** (*included*) to each side of the gate to alert the public of automatic gate operation. It is *your responsibility* to post warning signs on both sides of your gate. If any of these signs or warning decals become damaged, illegible or missing, replace them immediately. Contact GTO for free replacements.
2. The gate is automatic and could move at any time, posing a serious risk of entrapment. No one should be in contact with the gate when it is moving or stationary.
3. Do not attempt to drive into the gate area while the gate is moving; wait until the gate comes to a complete stop.
4. Do not attempt to "beat the gate" (drive through) while the gate is closing. This is extremely dangerous.
5. Do not allow children or pets near your gate. **Never let children operate or play with gate controls.** Keep the remote controls away from children and unauthorized users; store controls where children and unauthorized users do not have access to them.
6. **KEEP GATES PROPERLY MAINTAINED.** Always turn power to opener OFF before performing any maintenance. Clean the push-pull tube, spray a soft dry cloth with silicone spray and wipe the tube at least once per month.
7. Service the gate and gate opener regularly. Grease hinges, and replace the battery every 2-3 years.
8. To operate this equipment safely, YOU must know how to disconnect the opener for manual gate operation (*see page 1*). If you have read the instructions and still do not understand how to disconnect the opener, contact the GTO Service Department.
9. Disconnect the opener **ONLY** when the power is **TURNED OFF** and the gate is **NOT** moving.
10. Make arrangements with local fire and law enforcement for emergency access.
11. Distribute and discuss copies of the **IMPORTANT SAFETY INSTRUCTIONS** section of this manual with all persons authorized to use your gate.
12. **IMPORTANT: Save these safety instructions. Make sure everyone who is using or will be around the gate and gate opener are aware of the dangers associated with automated gates. In the event you sell the property with the gate opener or sell the gate opener, provide a copy of these safety instructions to the new owner.**

**Should you lose or misplace this manual, a copy can be obtained by downloading one from the GTO® Access Systems web site ([www.gtoaccess.com](http://www.gtoaccess.com)), by contacting GTO, at 3121 Hartsfield Road, Tallahassee, Florida 32303 or by calling 1-800-543-4283 and requesting a duplicate copy. One will be provided to you free of charge.**



# ⚠ IMPORTANT SAFETY INSTRUCTIONS ⚠

## Secondary Means of Protection Against Entrapment

As specified by Gate Operator Safety Standard, UL 325 (30A.1.1), automatic gate operators shall have an inherent entrapment sensing system, and shall have provisions for, or be supplied with, at least one independent secondary means to protect against entrapment. GTO gate openers utilizes **Type A**, an inherent (i.e., built-in) entrapment sensing system as the **primary** type of entrapment protection. Also, the gate opener has **provisions for** the connection of **Type B1 or B2** protection to be used as the **secondary** type of entrapment protection, if desired.

1. For gate operators utilizing a non-contact sensor (e.g., photo-electric sensor– Type B1) in accordance with UL 325 (51.8.4 [h]):
  - A. Refer to the sensor manufacturer’s instructions on the placement of non-contact sensors for each type of application.
  - B. Care shall be exercised to reduce the risk of nuisance tripping, such as when a vehicle trips the sensor while the gate is still moving.
  - C. One or more non-contact sensors shall be located where the risk of entrapment or obstruction exists, such as the perimeter reachable by a moving gate or barrier.
2. For gate operators utilizing a contact sensor (e.g., safety edge sensor– Type B2) in accordance with UL 325 (51.8.4 [i]):
  - A. One or more contact sensors shall be located at the leading edge, bottom edge, and post edge, both inside and outside of a vehicular swing gate system.
  - B. A hard wired contact sensor shall be located and its wiring arranged so that the communication between the sensor and the gate operator is not subjected to mechanical damage.
  - C. A wireless contact sensor such as one that transmits radio frequency (RF) signals to the gate operator for entrapment protection functions shall be located where the transmission of the signals are not obstructed or impeded by building structures, natural landscaping or similar obstruction. A wireless contact sensor shall function under the intended end-use conditions.

You may want to consider adding photo beams to your installation. GTO Photo Beams [R4222] provide a “non contact” means of entrapment protection.

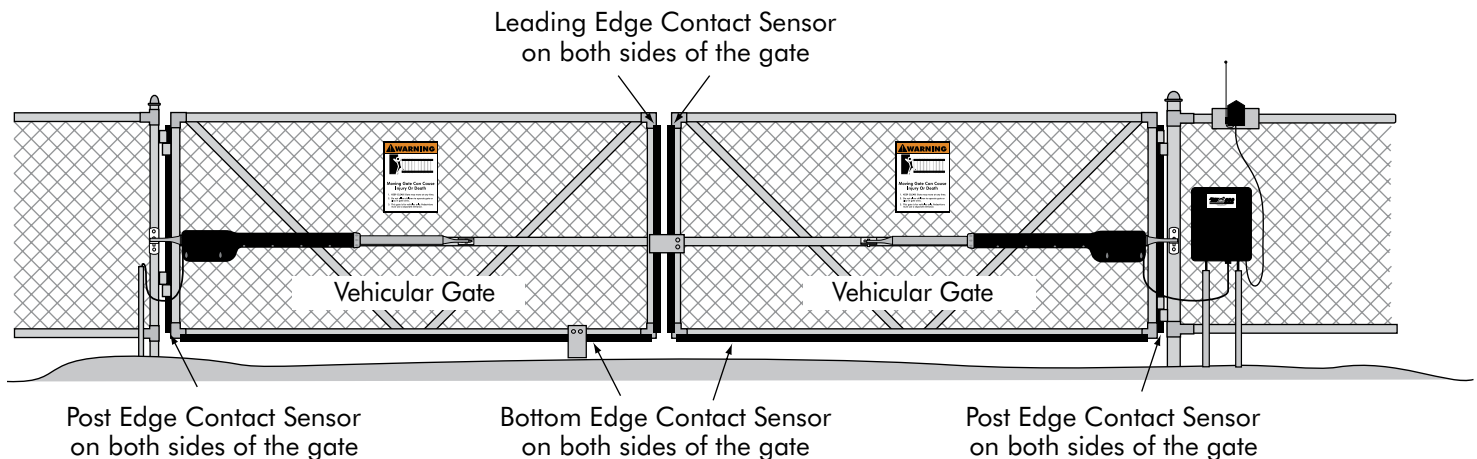

### ENTRAPMENT ALARM (UL 325; 30A.1.1A)

The GTO® Gate Opener is designed to stop and reverse within 2 seconds when the gate comes in contact with an obstruction. Additionally, these openers are equipped with an **audio entrapment alarm** which will activate if the unit obstructs **twice** while opening or closing. This alarm will sound for a period of 5 minutes, or until the opener receives an intended signal from a hard wired entry/exit source (e.g. push button control or keypad) and the gate returns to a fully open or fully closed position. Turning the power switch on the control box OFF and back ON will also deactivate the alarm. Wireless controls such as transmitters and wireless keypads will not deactivate the alarm.

# ⚠ IMPORTANT SAFETY INSTRUCTIONS ⚠

## Required Safety Precautions for Gates Install Warning Signs

**Warning signs** alert people of automatic gate operation and are **required** when installing the GTO® gate opener. Furthermore, a walk-through gate must be installed if pedestrian traffic is expected near the vehicular gate. We recommend using the **GTO Bulldog Pedestrian Gate Lock** (Call the GTO Sales Department at 1-800-543-4283) for controlled access.

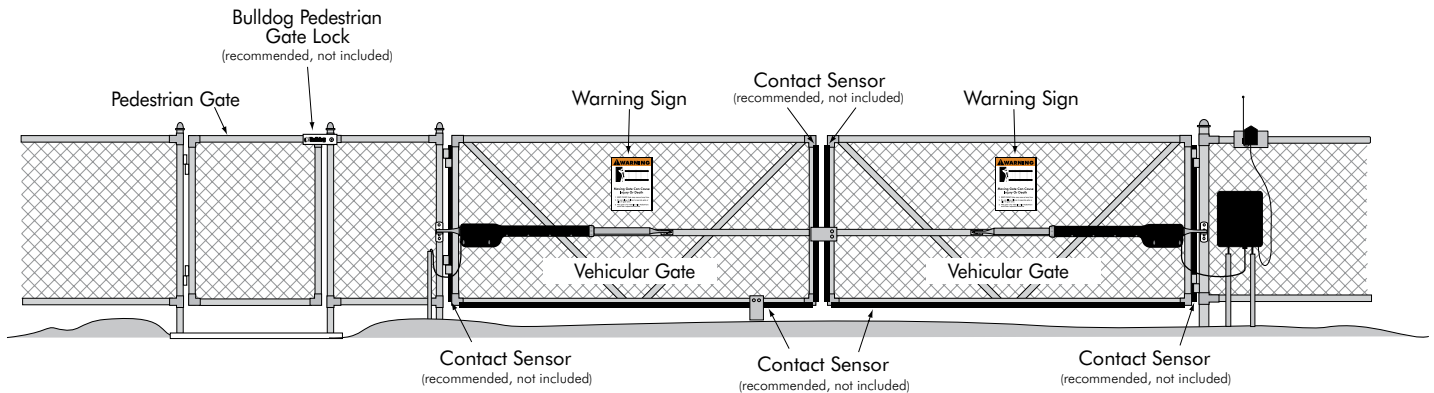

## Entrapment Protection

GTO's inherent obstruction settings, even when properly adjusted, *may not be sensitive enough to prevent bodily injury in some circumstances*. For this reason, safety devices such as safety edge sensors (or photoelectric sensors), which stop and reverse gate direction upon sensing an obstruction, are suggested for enhanced protection against entrapment.

### Warning Signs

The warning signs (*at right*) must be installed on both sides of the gates (*see page 7 for details*).



# ⚠ IMPORTANT SAFETY INSTRUCTIONS ⚠

**WARNING**

**Moving Gate Can Cause Injury Or Death**

- 1. KEEP CLEAR! Gate may move at any time.**
- 2. Do not allow children to operate gate or play in gate area.**
- 3. This gate is for vehicles only. Pedestrians must use a separate entrance.**

These warning labels should be found at the locations specified below. If any of them are missing, immediately contact GTO for replacements.

**GTO DC SWING SERIES / 500**  
**Conforms to UL 325 STANDARDS**  
 Maximum Gate: 500 lb. (226.7 kg); 16 ft. (4.8 m)  
 Voltage: 12 Vdc; Frequency: 0 Hz; Power: 25 W  
 Class I, II, III and IV Vehicular Swing Gate Operator.  
 Serial Number: XXXXXXXXX

---

**TO MANUALLY OPEN AND CLOSE THE GATE:**

1. Turn control box power switch OFF.
2. Disconnect front or rear mount from gate bracket.
3. Pull opener away from front or rear mount.

**Disconnect operator ONLY when the control box power switch is OFF and the gate is NOT moving.**

GTO Access Systems, LLC • Tallahassee, Florida USA

*Product identification and manual operation instruction label (1) installed on the right side of the control box.*

*Warning signs (2 enclosed) to be installed on each side of the gate (3–5 feet above the bottom of the gate)*

**MIGHTY MULE 502**

**E-Z GATE® OPENER UL325 SERIES**

1-800-543-GATE (4283) • www.mightymule.com

**WARNING**

**MOVING GATE  
Can Cause Injury or Death**

1. KEEP CLEAR! Gate may move at any time.
2. Do not allow children to operate gate or play in gate area.
3. This gate is for vehicles only. Pedestrians must use separate entrance.

*Logo and warning labels (2) installed on each side of opener housing*

# Dual Gate Opener Parts List

## Opener and Mounting Hardware

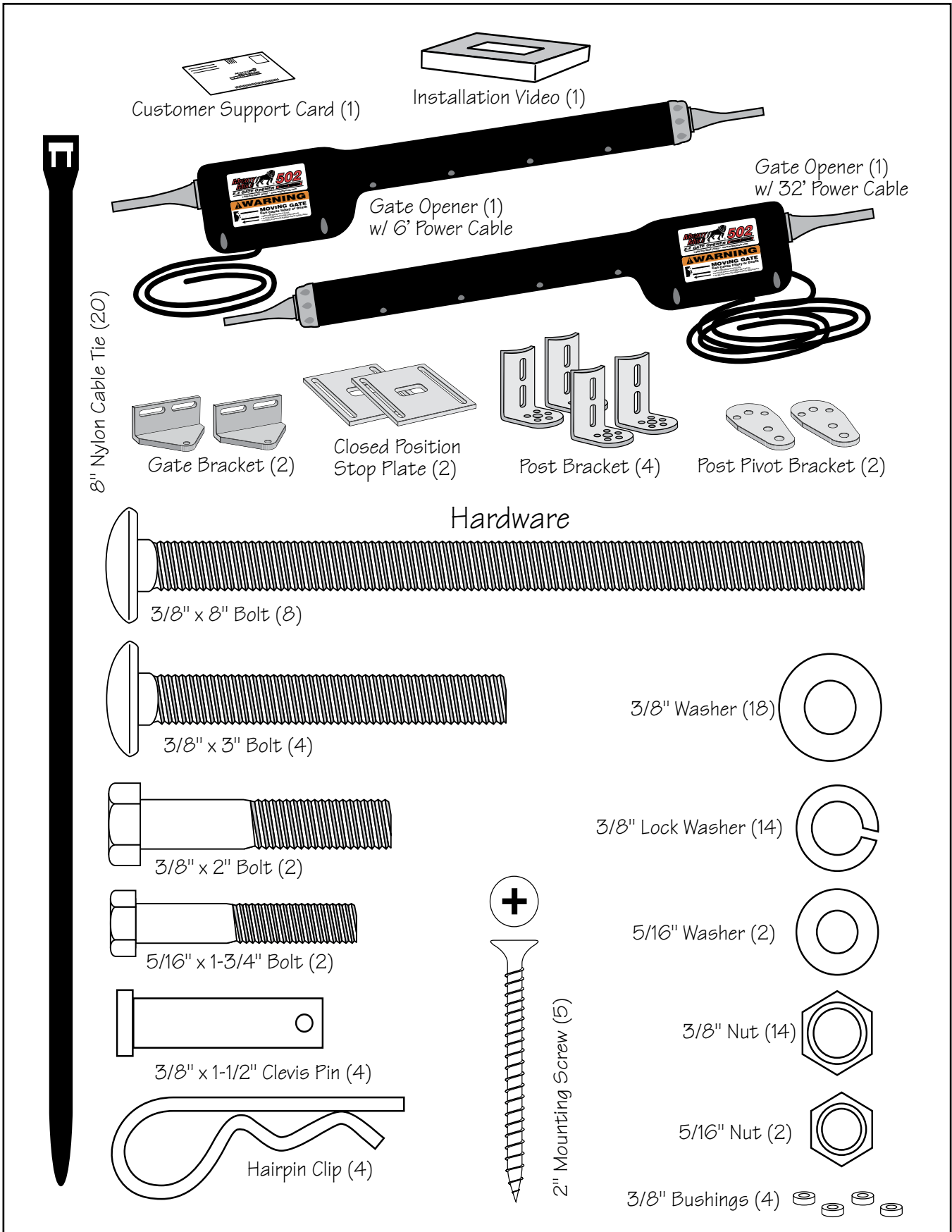

# Dual Gate Opener Parts List (continued)

## Control Box and Electrical Components

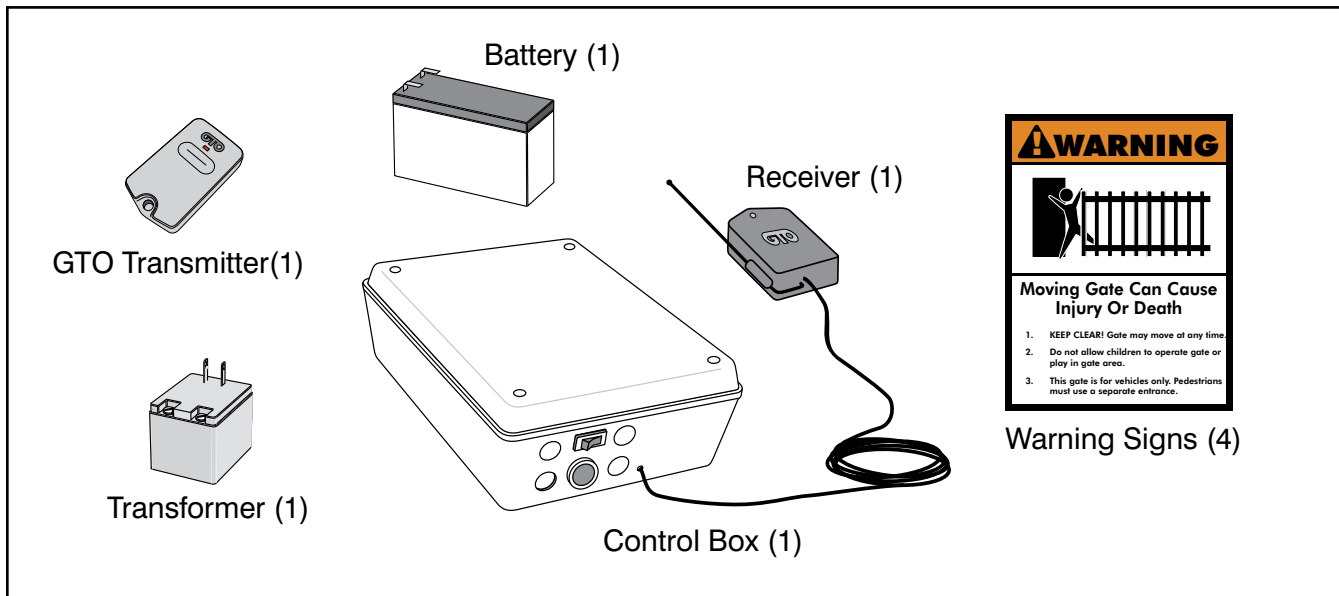

### Tools Needed

- Power Drill
- Open End Wrenches — 9/16" and 1/2"
- Long 3/8" and 5/16" Drill Bit
- Hacksaw or Heavy Duty Bolt Cutters
- Small (Flat Bladed) Screwdriver
- Phillips Screwdriver
- Tape Measure
- Level
- Wire Strippers
- C-Clamps — small, medium, and large
- Center Punch
- An extra person will be helpful

### YOU MAY ALSO NEED THESE ITEMS BEFORE YOU BEGIN THE INSTALLATION

(Some of these items can be found in the *Accessory Catalog* page 37):

- **Low voltage wire** will be needed to run from the transformer to the control box; length depends upon the distance between the transformer power supply and the control box. See **Powering the System** on page 21, and the *Accessory Catalog*.
- If your gate is more than 1000' away from an ac power source you will need to use at least 10 to 30 Watts of solar charging power to trickle charge the battery. See the *Accessory Catalog*.
- If your fence post is made of wood and is less than 6" in diameter or 6" square, see page 12.
- If your fence post is larger than 6" in diameter you will need **threaded rods or carriage bolts longer than 8"**. See page 15.
- PVC conduit.
- If you have thin walled tube or panel gates, see **Recommended Reinforcement Examples** on page 12.
- Depending on the type of gate, a **horizontal cross member or mounting plate may be needed** to mount the front of the opener and gate bracket to the gate. See page 11, step 2; page 15, step 10.
- Surge protection for transformer.
- Some types of installations require U-Bolts.
- If the gate is a push-to-open refer to page 30
- Additional washers or a metal plate may be needed for wooden post.

# Technical Specifications

## GTO® GATE OPENER

### DRIVE

- Low friction screw drive (linear actuator) rated for -5 °F to +160 °F (-28 °C to +71 °C).
- Powered by a 12 V motor with integral case hardened steel gear reducer. Motor speed reduced to 260 rpm.
- Maximum opening arc of 110°. Approximate opening time (90°): 20 seconds, depending on weight of gate.

### POWER

- The system is powered by two 12 Vdc, 7.0 Ah, sealed, rechargeable acid batteries.
- Battery charge is maintained by a 18 Vac output transformer rectified to 14.5 Vdc (20 VA) through the GTO control board. One (1) blade-style control board fuse rated for 25 A.  
**NOTE: The transformer should not be directly connected to any battery. Do not replace fuses with higher ampere rated fuses; doing so will void your warranty and may damage your control board.**
- Battery charge is maintained by GTO Solar Panel Charger kit (5 Watt minimum).

### CONTROL

- GTO microprocessor-based control board is set for single leaf, pull-to-open gate installations. DIP switches can be adjusted to accommodate an optional kit for push-to-open gates (*see Accessory Catalog*).
- A circuit on the control board regulates charging. "Sleep draw" is 40 mA; "active draw" is 2 to 5 A.
- Auto-memorization of digital transmitter code.
- GTO remote-mounted RF receiver tuned to 318 MHz.
- Opener length with push-pull tube fully retracted is 40<sup>1/4</sup>", mounting point to mounting point. Max stroke 22".
- Adjustable auto-close timer and obstruction sensitivity.
- Power terminal block accommodates a transformer or solar panels.
- DIP switches simplify setup of gate opener.
- Accessory terminal block is fully compatible with push button controls, digital keypads, safety loops, etc.
- Control board allows connection of safety edge sensors and photoelectric sensors.
- Audio entrapment alarm sounds if the unit encounters an obstruction twice while opening or closing.

### OPERATIONAL CAPACITY

- The Gate Capacity Chart shows approximate cycles, per day, you can expect from the GTO® Automatic Gate Operator when powered with a transformer. Actual cycles may vary slightly depending upon the type and condition of gate and installation.

**NOTE:** "NR" indicates this size and weight combination is not recommended for the GTO® gate openers.

**IMPORTANT: BALL BEARING HINGES SHOULD BE USED ON ALL GATES WEIGHING OVER 250 Lbs.**

#### Mighty Mule 502 Gate Capacity /Cycle Chart

*Estimated number of daily cycles, based on use with a transformer and one(1) 12 Volt battery.*

#### Number of Cycles Per Day

Gate Weight	850 lbs.	68	63	NR	NR	NR	NR	NR
	750 lbs.	73	68	63	NR	NR	NR	NR
	650 lbs.	78	73	68	63	NR	NR	NR
	550 lbs.	83	78	73	68	63	NR	NR
	450 lbs.	88	83	78	73	68	63	NR
	350 lbs.	93	88	83	78	73	68	63
	250 lbs.	98	93	88	83	78	73	68
	150 lbs.	103	98	93	88	83	78	73
	100 lbs.	108	103	98	93	88	83	78
	50 lbs.	113	108	103	98	93	88	83
		5' - 6'	8'	10'	12'	14'	16'	18'

Gate Length

NR = NOT RECOMMENDED

To determine the number of cycles the gate opener will perform using solar panels, please see the specifications listed on *page 21*.

\* An operation cycle is one full opening and closing of the gate.

**These specifications are subject to change without notice.**

# Installation Overview

## Pull-to-Open Gates (Gate Opens into the Property)

The diagram shown below is an example of a pull-to-open installation on a chain link fence and dual gates. Mounting the openers on a masonry column requires special procedures; see **Column Installation Information** on page 38 if you intend to mount the openers on columns. Furthermore, if you have push-to-open gates, you will need to purchase two (2) **push-to-open brackets** (see *Accessory Catalog*) to properly configure your system. See **Push to Open Installation** on page 32 before proceeding.

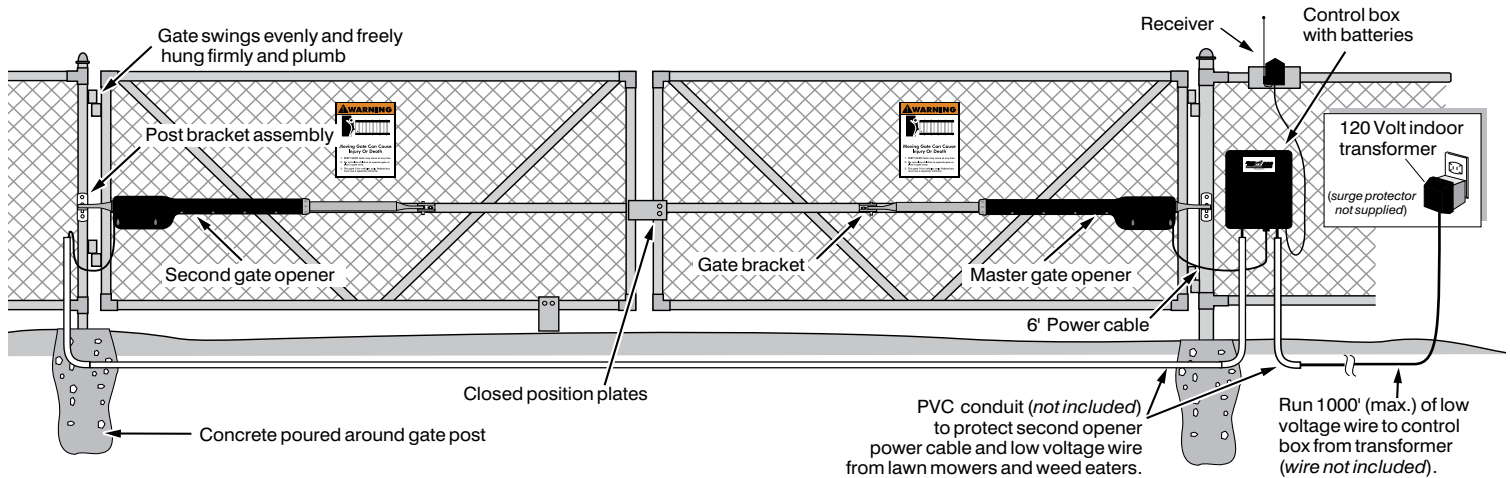

## Preparation of the Gate

### Step 1

The gates **must** be plumb, level, and swing freely on their hinges. Wheels must not be attached to the gates. The gates must move throughout their arc **without binding or dragging on the ground**. Note that gates over 250 lb. should have ball bearing hinges with grease fittings.

### Step 2

The fence posts must be secured in the ground with concrete so they will minimize twist or flex when the openers are activated. We recommend you position the openers near the **centerline** of the gates to keep the gates from twisting and flexing and to avoid backsplash from rainwater. The addition of **horizontal or vertical cross members** (if they are not already in place) to provide a stable area for mounting the gate brackets is also important.

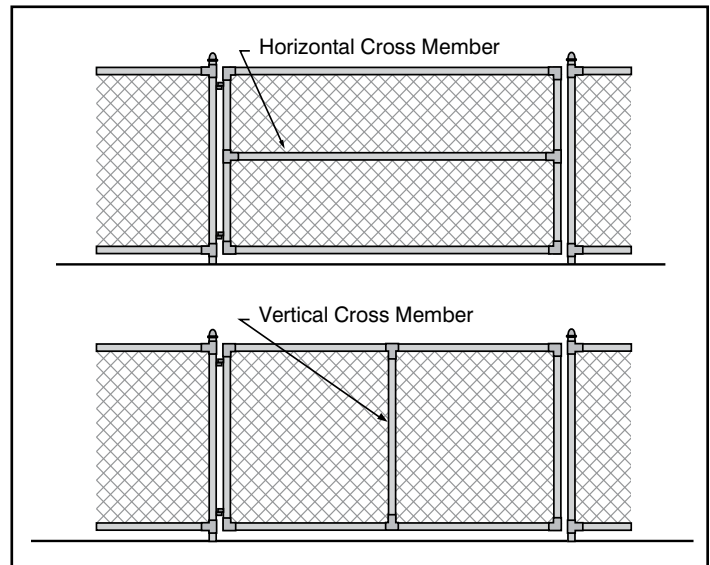



# Installation of Mounting Hardware

The position of the post bracket determines the leverage and efficiency of the opener. The post bracket position also sets the clearance between the opener and gate in the open and closed positions (minimum 2 inches).

The curved design of the post bracket works well for installations on round and square fence posts. Because the post bracket carries the entire thrust of the active opener, **bolts that completely penetrate the fence post must be used.**

On wooden posts, place a metal plate or washer (not supplied) between the nuts and the fence post to prevent the thrust of the opener from pulling the bolts and washers out of the wood.

**NOTE:** A fence post smaller than 6" in diameter or 6" square should be made of metal instead of wood so that it will remain stable while the opener is moving the gate.

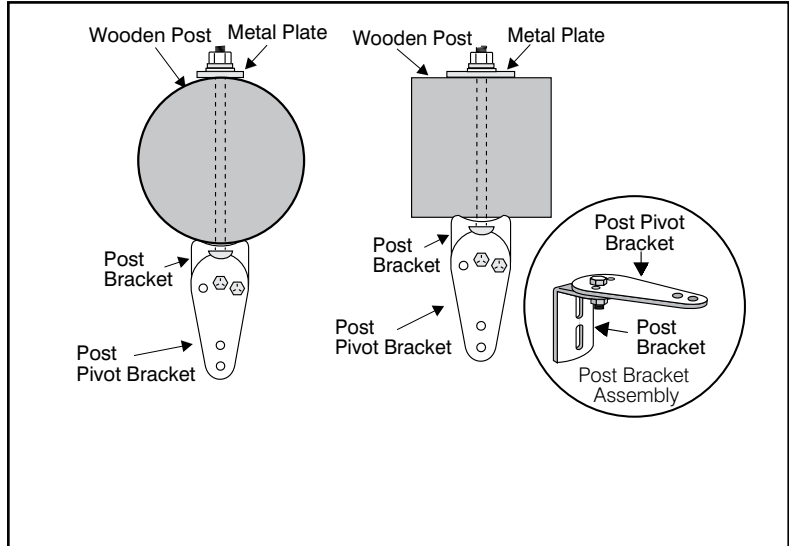
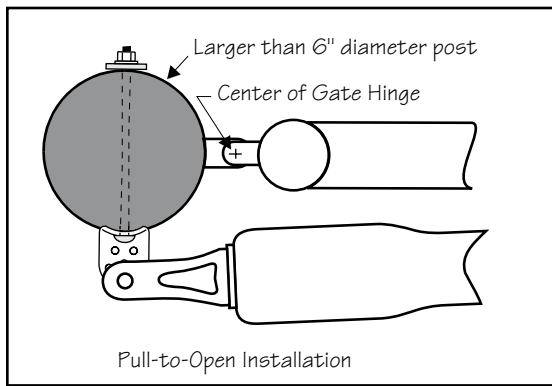

On round posts of 6" diameter or larger, the post pivot bracket may not be necessary for the installation. In this instance, the two post brackets are mounted by themselves.

## IMPORTANT:

We **strongly recommend** using steel pipe, wood or metal to reinforce thin walled tube gates or wood to reinforce panel gates as shown. These reinforcement methods will prevent damage to the opener and gate when the opener is installed.

## Recommended Reinforcement Examples

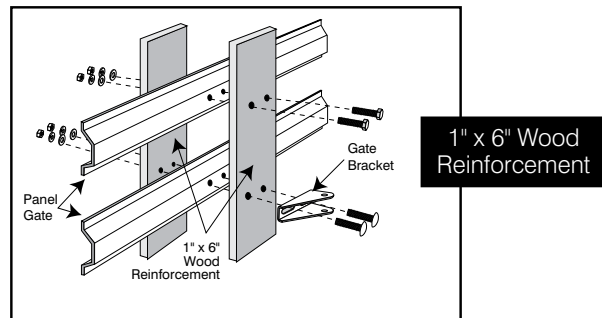
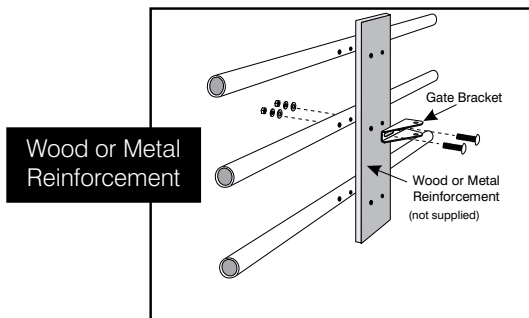
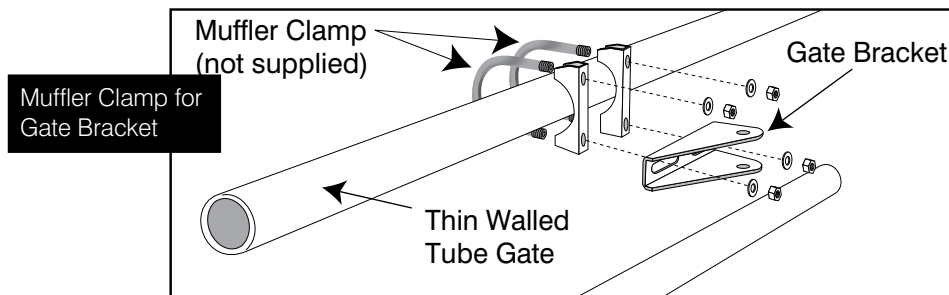



# Determining the Mounting Position of the Post Bracket Assembly and the Gate Bracket

## Step 3

Insert the 3/8" x 2" bolt through the center hole of the post brackets and post pivot bracket as shown. Fasten a 3/8" lock washer, 3/8" washer and 3/8" nut on the end of the bolt. **DO NOT overtighten** the nut because the post pivot bracket will have to be adjusted later.

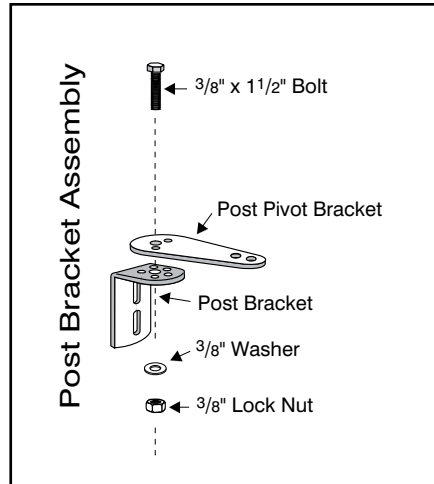

**NOTE:** The following steps are intended for **pull-to-open** gate installations. If you are mounting your gate openers on a push-to-open gate (e.g., a gate on a sloped driveway) you will need to purchase two **Push To Open** brackets (see *Accessory catalog*). Also, see **Push-to-Open Installation** beginning on page 30.

## Step 4

Attach post bracket assembly and gate bracket to the opener with the clevis pins and bushings. Secure the clevis pins with hairpin clips.

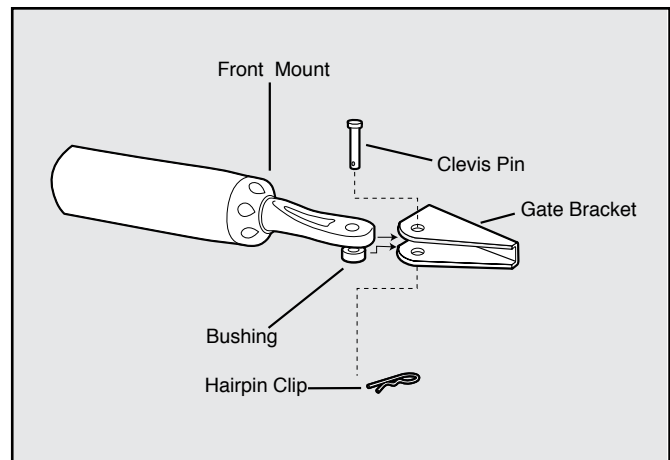
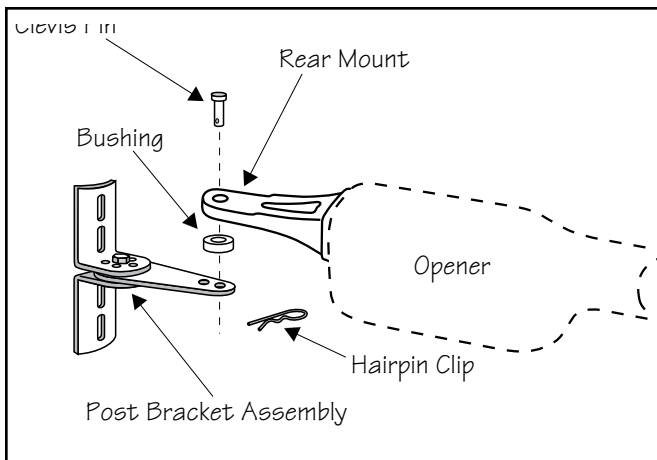

## Step 5

With the gate in the open position (up to 110° from its closed position) and the gate opener arm fully retracted, adjust the post bracket assembly and gate bracket until the opener is level. While holding the opener level, use C-clamps to **temporarily** secure the post bracket assembly and gate bracket to the fence post and gate.

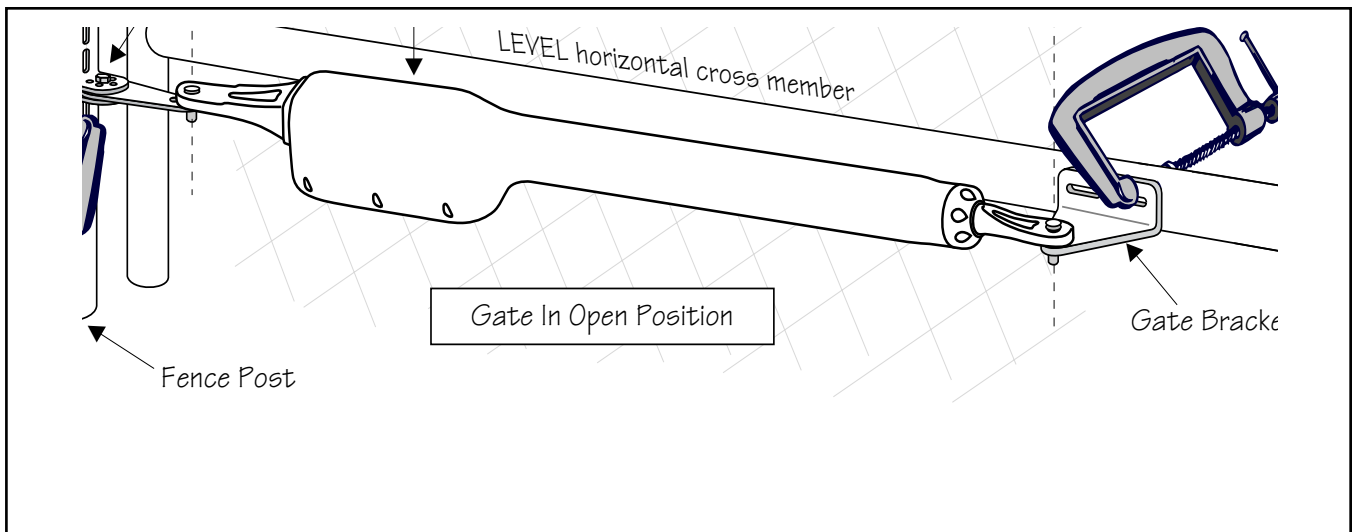

**IMPORTANT:** While determining the mounting point for the post pivot bracket assembly, be sure that the position allows for minimum 2 inches of clearance between the gate and the opener in both the open and closed positions, as shown in the diagrams below. This clearance will give the opener the most efficient leverage point for opening and closing the gate and more importantly provides the least possible pinch area.

## Step 6

When you feel that you have the best position for the post pivot bracket in the open position, insert the 5/16" x 1-3/4" bolt through the aligned holes of the post bracket and post pivot bracket to hold it in place. Remove the clevis pin from the front mount and while supporting the gate opener, swing the gate and gate opener to the closed position. With the gate and gate opener in the closed position check the clearance and be sure that the gate opener is not binding at the post pivot bracket.

If you don't have 2 inches of clearance or the gate opener is binding on the post pivot bracket, remove the 5/16" x 1-3/4" bolt and readjust the pivot bracket until you can achieve these important clearances.

With the post pivot bracket in the optimum position for clearance and freedom of movement, reattach the opener to the gate bracket in the open position and recheck the gate opener level and make sure the brackets are clamped securely.

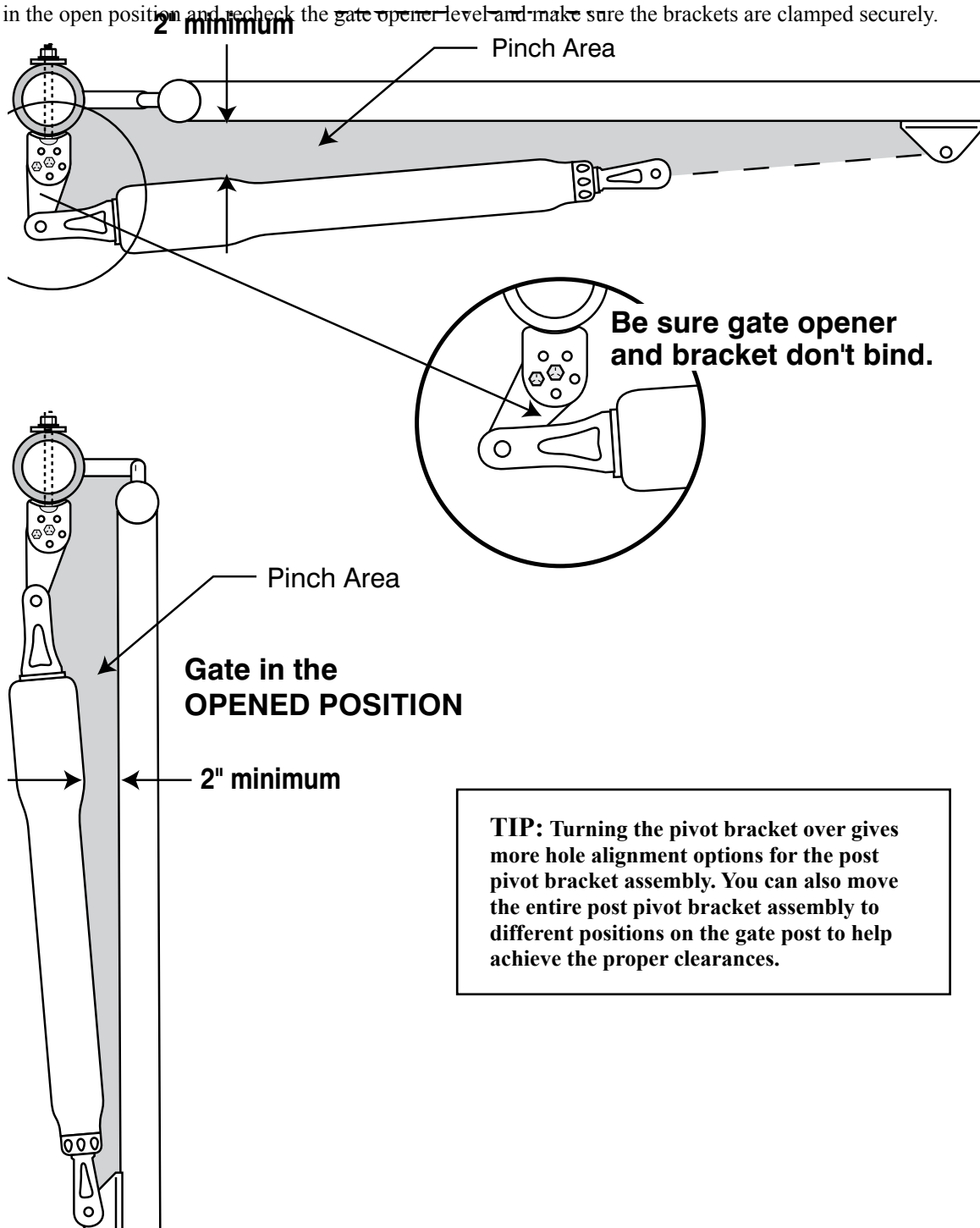

# Installing the Post Bracket Assembly and Gate Bracket

## Step 7

Mark reference points for bolt holes on the fence post through middle of bracket slots. Mark reference points for bolt holes on the gate cross member through middle of gate bracket slots. After marking your reference points, remove the opener and brackets from the fence and gate.

## Step 8

Drill  $\frac{3}{8}$ " holes into fence post as marked.

## Step 9

Fasten post bracket assembly to the fence post using (4)  $\frac{3}{8}$ " x 8" bolts, washers, lock washers, and nuts (*provided*).

**NOTE:** In cases where the fence post has a diameter larger than 6", **threaded rods or carriage bolts longer than 8"** (*not supplied*) must be used.

## Step 10

Drill  $\frac{3}{8}$ " holes into the gate cross member as marked.

Mount gate bracket using (2)  $\frac{3}{8}$ " x 2- $\frac{3}{4}$ " bolts, washers, lock washers, and nuts (*provided*).

**NOTE:** After the gate opener installation is complete and operation of the opener system has been tested, you should remove excess bolt length extending beyond the tightened nuts with a hacksaw or bolt cutters.

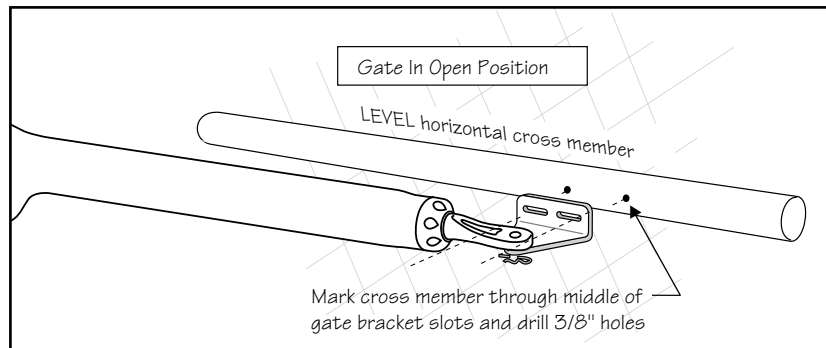
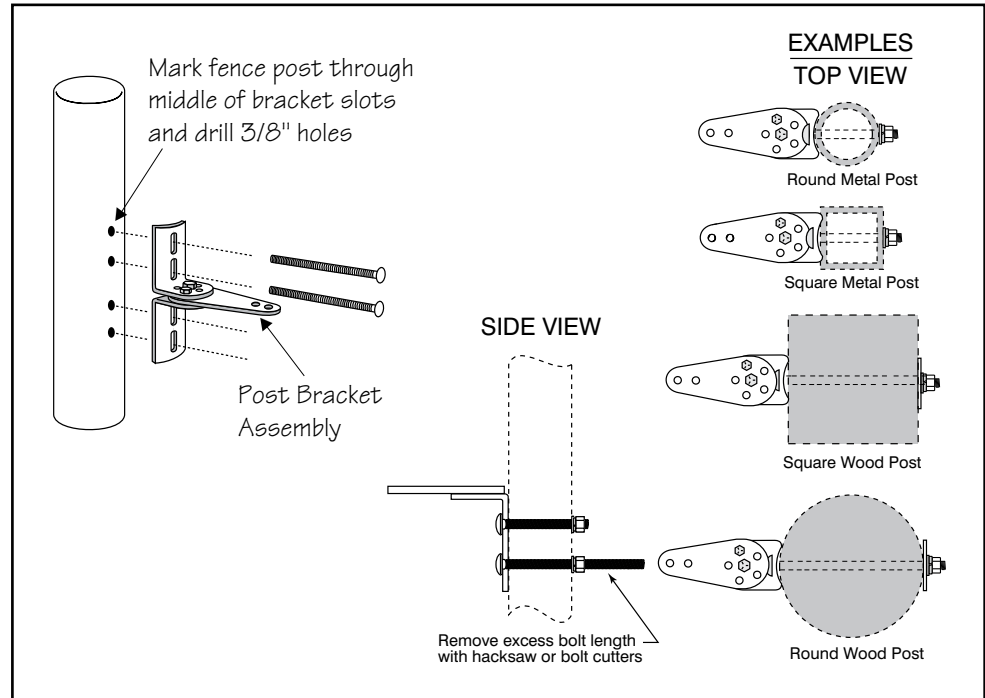

## Gate Bracket Mounting Examples

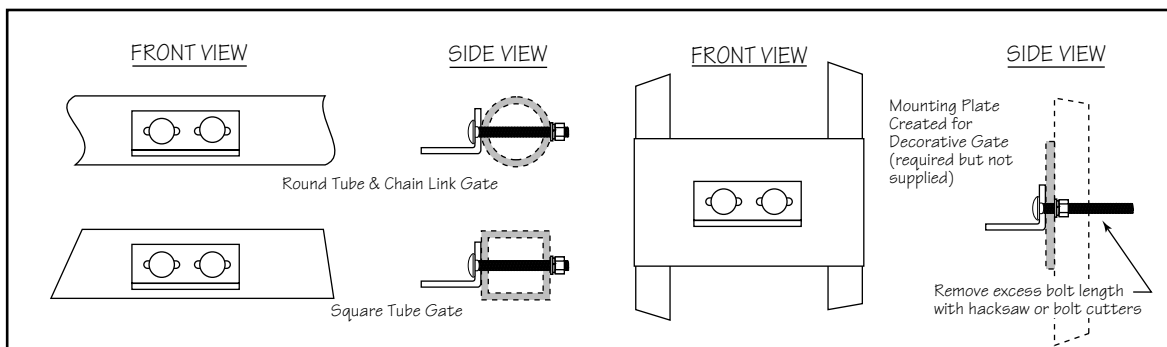

# Mounting the Master Opener

## Step 11

Attach the opener to the securely bolted post bracket assembly and gate bracket using clevis pins, bushings, and hairpin clips, or the Pin Locks (included). Verify that the opener is level and adjust the post bracket assembly if necessary.

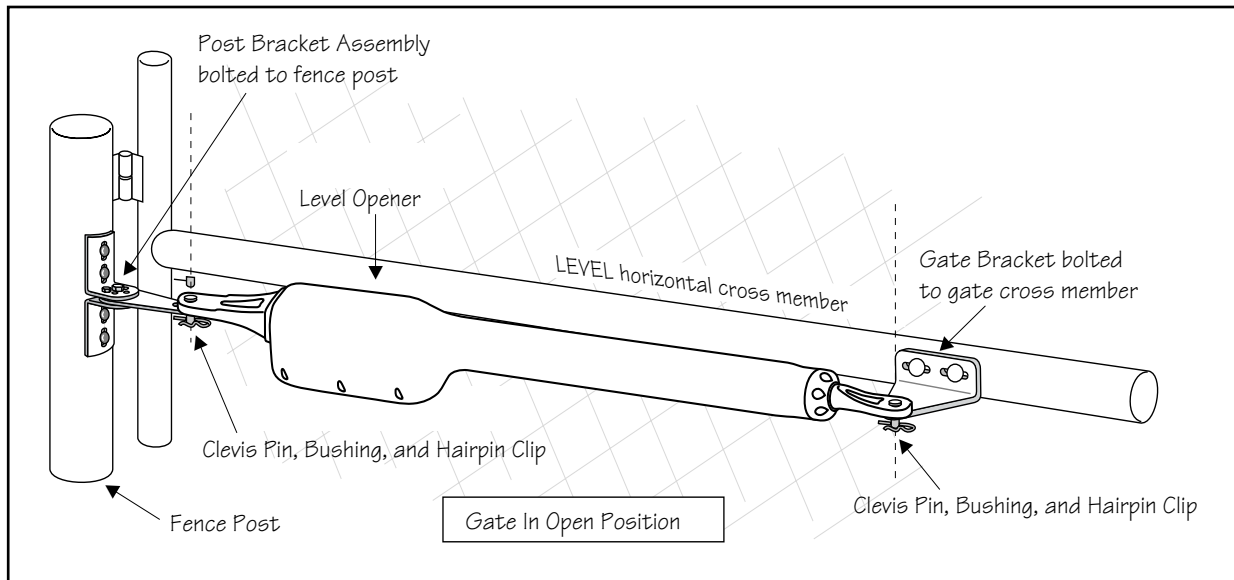

# Installing the Second Opener

## Step 12

Install the second opener on the remaining gate leaf by repeating **Step 3** through **Step 11**, starting on page 13. After you have mounted the second opener, proceed to **Installation of the Closed Position Stops** on the next page.

# Installation of the Closed Position Stops

The GTO® Gate Openers firmly hold the gates in the closed position using positive stops. The positive stops help stabilize the gate leaves in the closed position. To further enhance stability and security, we strongly recommended using an optional **GTO® Automatic Gate Lock** (see *Accessory Catalog*) with your dual gate.

**IMPORTANT:** You need to determine which side of the driveway you will mount the control box. From this point on the gate and gate opener on the same side as the control box will be referred to as the **MASTER** gate and gate opener. The gate and gate opener on the opposite side of the driveway from the control box will be referred to as the **SECOND** gate and gate opener.

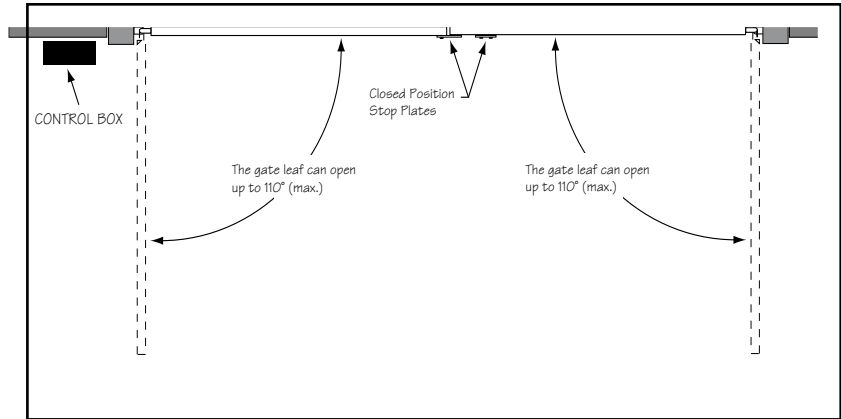

Illustration A

## Step 1

Attach the horizontal closed position stop plate to the **MASTER** gate leaf.

Detach the gate operators from the gates and move the gates to their closed position (*Illustration A*). Using appropriate hardware for your type of gate (U-bolts for tube or chain link; screw or bolts for wood or metal) attach the *closed position stop plate* (**horizontally**) about mid height on the **MASTER** gate frame. **Do not** tighten it completely at this time. Slide the stop plate toward the frame of the **SECOND** gate leaf until they touch (*Illustration B*). Once you have moved the stop plate to the correct position, tighten its hardware completely.

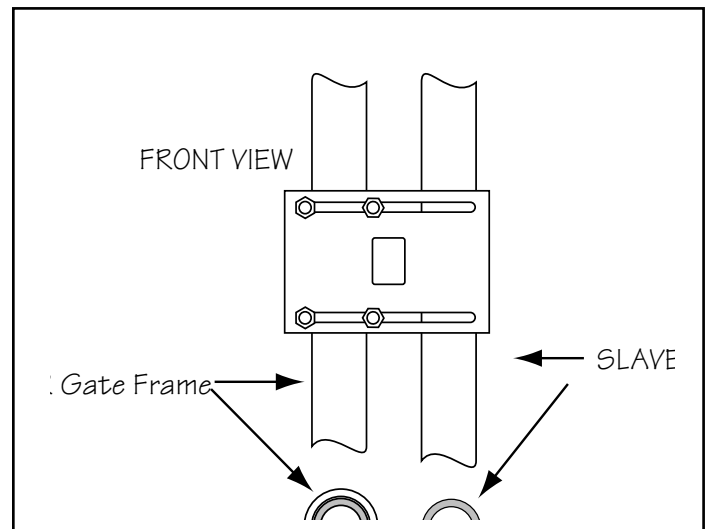

Illustration B

**NOTE:** The optional ground stop post is used to provide a secure point for the **SECOND** gate to close against. If you will be using the GTO Horizontal Gate Lock accessory with your gate opener system, the closed position ground stop is **REQUIRED**, as shown in Steps 2 and 3 on the next page.

## Step 2

Install a low profile ground stop (*not provided*) beneath the SECOND gate stop plate.

The ground stop needs to be positioned near the end of the gate as shown in *Illustration A* and may be made of metal or concrete and should be firmly secured in the ground (we recommend setting it in concrete).

## Step 3

Attach a vertical closed position stop plate to the SECOND gate.

Using appropriate hardware for your type of gate attach the vertical *closed position stop plate* to the SECOND gate frame at the point where it will come in contact with the ground stop post.. **Do not** tighten it completely at this time. You must slide the closed position stop plate toward the *ground stop* until they touch (*Illustration C*). Once you have moved the stop plate to the correct position, tighten its hardware completely.

**NOTE:** For a push-to-open installation (gate opens *out* from the property) attach the closed position stop plate to the **outside** of the gate.

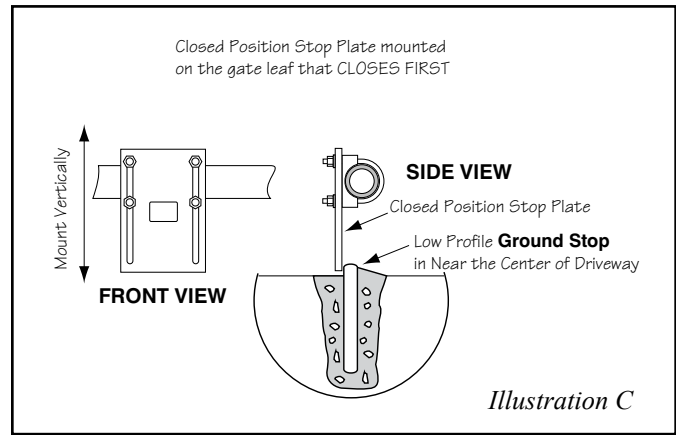

**At this stage of the installation, the openers should be installed on the gate leaves and the open and closed position stops should be in place.**

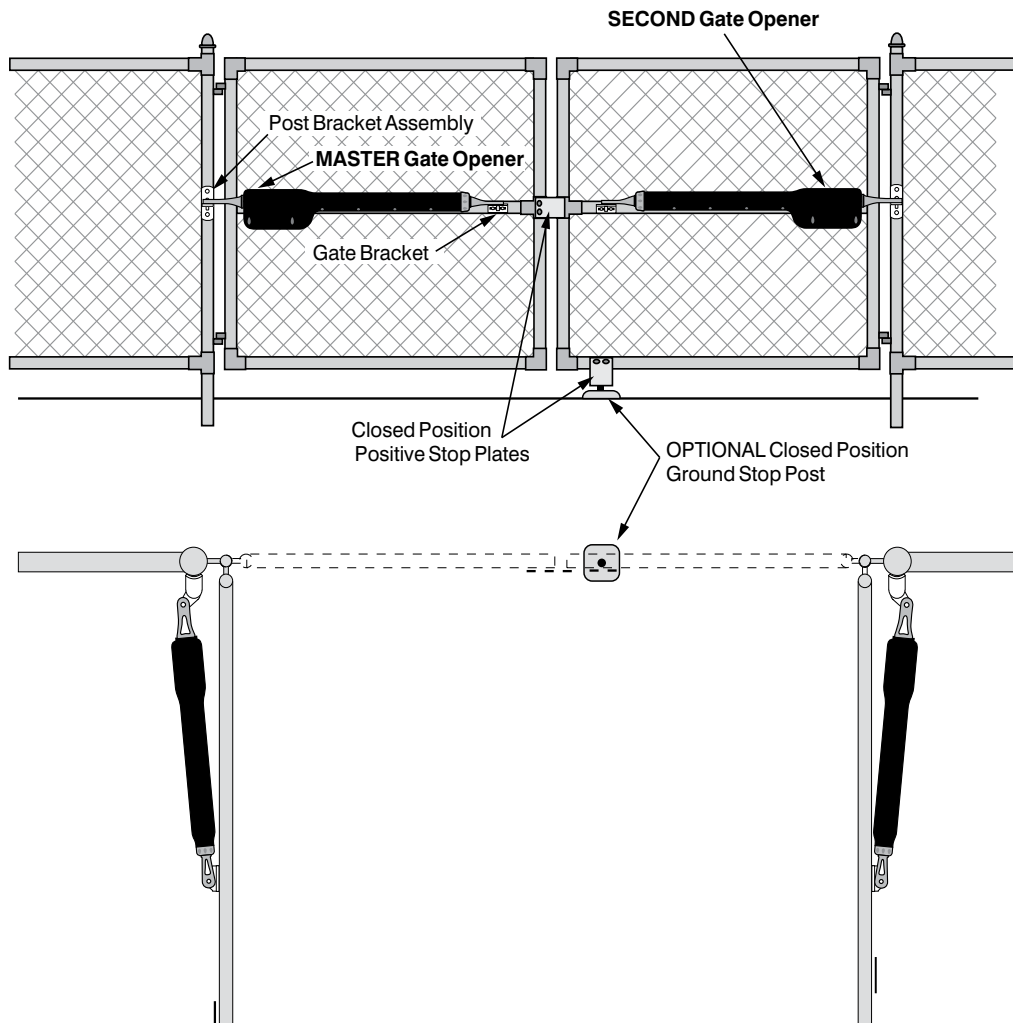

# Mounting the Control Box

## Step 1

Mount the control box using the screws (*provided*) or another secure mounting method. The control box must be mounted at least **3 feet above the ground** to protect it from rain splash, snow, etc., and at least **3 feet from an AC power source** to prevent electrical interference.

**NOTE:** The batteries that came with your GTO® gate opener, **MUST** be placed in the top (horizontal) battery slot with the terminals on the **RIGHT**. The extra (vertical) battery slot is for the second battery.

Use mounting holes and screws provided to mount control box to a secure surface.

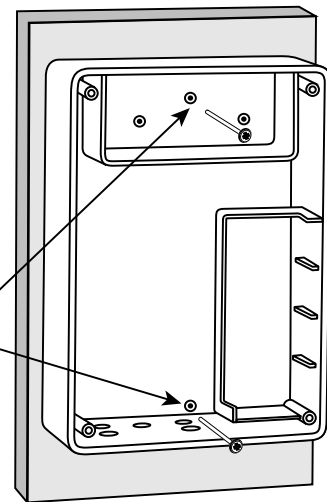

## Step 2

Make sure the control box power switch is in the **OFF** position. The ON/OFF Switch is located on the bottom of the control box. Remove the control box cover and slide the battery into position with its terminals to the **RIGHT** (*see illustration*). Connect the **BLACK** battery wire to the **NEGATIVE** (-) battery terminal. Connect the **RED** battery wire to the **POSITIVE** (+) terminal. *Pay close attention to the color of the wires. If the wires are connected incorrectly, the control board will be damaged. NEVER insert the battery with the terminals to the left.*

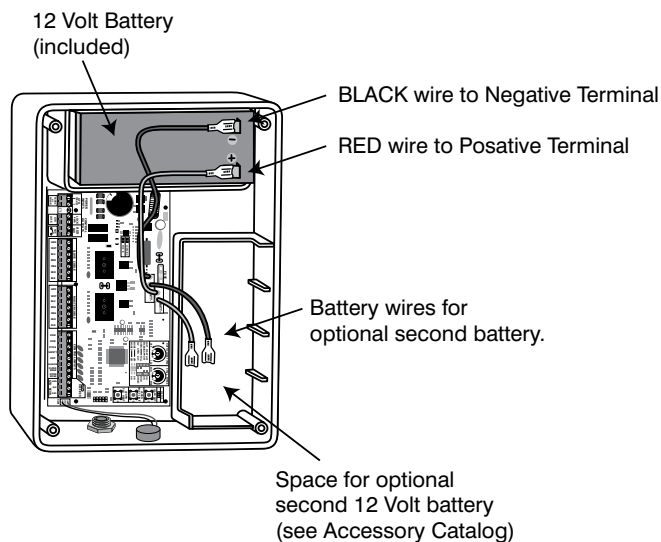

## Step 3

Strip approximately  $\frac{3}{16}$ " of insulation from each wire of the power cable. Twist each exposed wire tightly (there are seven [7] wires inside the power cable sheath). Loosen sealing nut on strain relief hub at bottom of control box. Insert power cable into control box through strain relief. Thread approximately 6" of the power cable into the control box and re-tighten sealing nut until the power cable locks into place.

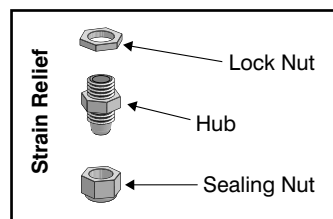

# Connecting Opener Power Cables

## MASTER Operator

### Step 4

Insert the stripped power cable wires into the appropriate terminals on the **MASTER CABLE** terminal block. The green wire should be inserted into the **GRN** terminal, the white wire into **WHT**, the blue wire into **BLU**, brown wire into **BRN**, the orange wire into the **ORG**, the red wire into the **RED**, and the black wire into the **BLK** terminal.

Tighten the set screws against the end of the wires.

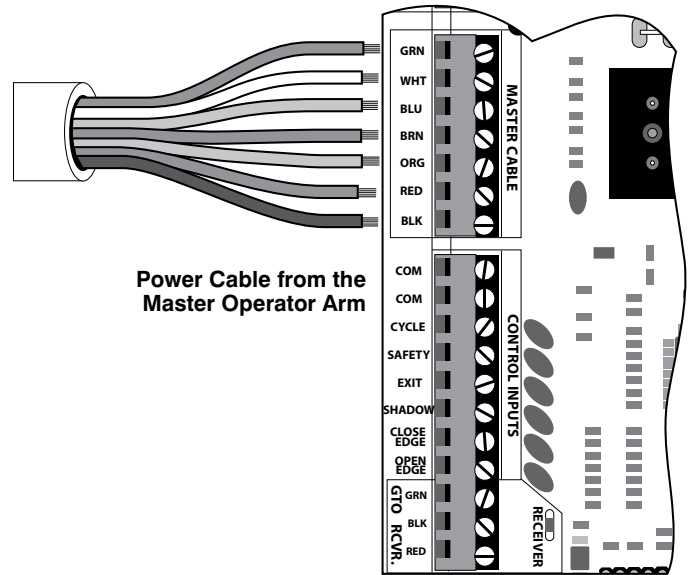
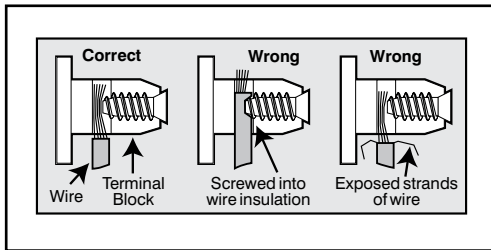

## SECOND Operator

### Step 5

Review the **Installation Overview** illustration on *page 11* before proceeding.

Cut a 6" deep slot into the driveway to accommodate PVC conduit (*not provided*). The buried conduit will protect the 32 foot power cable from automobile tires, lawn mower blades, weed eaters, and grazing animals. Pull the second opener power cable through the conduit and secure them into the slot in the driveway.

### Step 6

Strip approximately  $\frac{3}{16}$ " of insulation from each wire of the second opener power cable. Twist each exposed wire tightly. Insert the second opener power cable upward through the **right strain relief** (if necessary, loosen the sealing nut). Thread approximately 4" of wire into the control box. Re-tighten strain relief (on the **black sheath** of the power cable) until the power cable locks into place.

Insert the stripped wires of the power cable into the appropriate terminals on the **SECOND** operator terminal block. The green wire should be inserted into the **GRN** terminal, the white wire into **WHT**, the blue wire into **BLU**, brown wire into **BRN**, and the orange wire into the **ORG** terminal, red wire into **RED**, and black wire into **BLK**.

Tighten the set screws against the end of the wires.

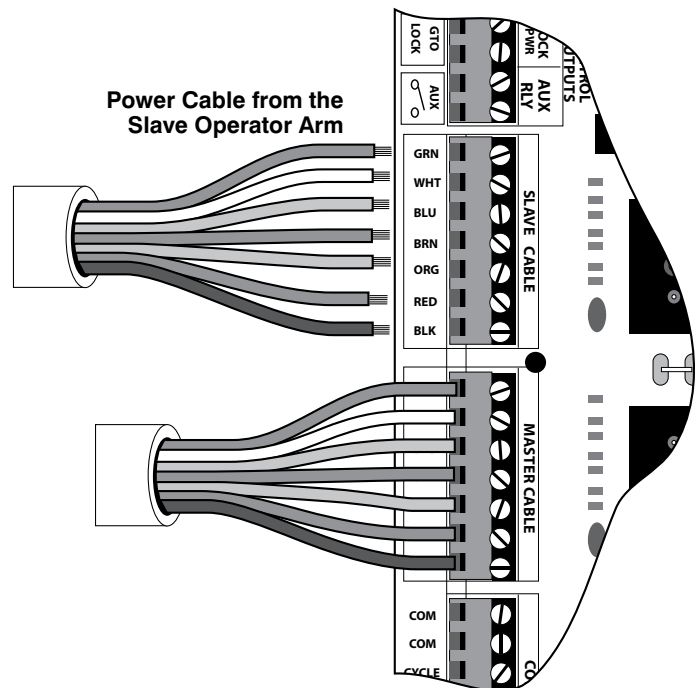



# Powering the System

## Installation of the Transformer

### IMPORTANT:

- The transformer is designed and intended for indoor use. If the transformer can be plugged only into an outside electrical outlet, a weatherproof cover or housing (available at local electrical supply stores) **must** be used.
- All low voltage wire used with the GTO® Gate Opener must be 16 gauge dual conductor, stranded, direct burial wire (*see page 22 and the accessory pages*). **Do not run more than 1000 feet of wire.**
- If your gate is more than 1000 ft. from an ac power source, you will need to use at least one 10 watt Solar Panel to charge the battery (*see the accessory pages*). Refer to the **Solar Panels and Gate Activity** chart below.

## OPTIONAL Solar Panels and Gate Activity

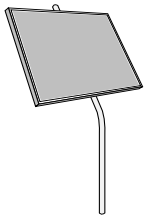

The table and map illustrate the maximum number of gate cycles to expect per day in a particular area when using from 10 to 30 watts of solar charging power. (*see Accessory Catalog*). The figures shown are for winter

(minimum sunlight) and do not account for the use of any accessory items. *Accessories connected to your system will draw additional power from the battery.*

**NOTE:** A maximum of 30 watts of solar charging power can be connected to the GTO® Gate Opener. Consult *Solar Panel Installation Instructions* for further information.

Winter Ratings	Zone 1	Zone 2	Zone 3
12 v dual gate (10 watts) solar charger	4	8	13
12 v dual gate (15 watts) solar charger	7	13	20
12 v dual gate (20 watts) solar charger	10	18	27
12 v dual gate (25 watts) solar charger	13	23	34
12 v dual gate (30 watts) solar charger	16	28	41

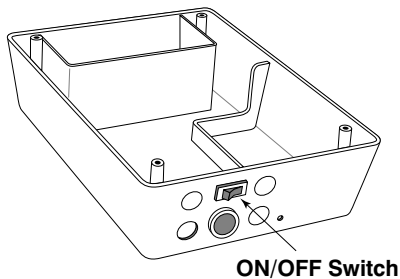
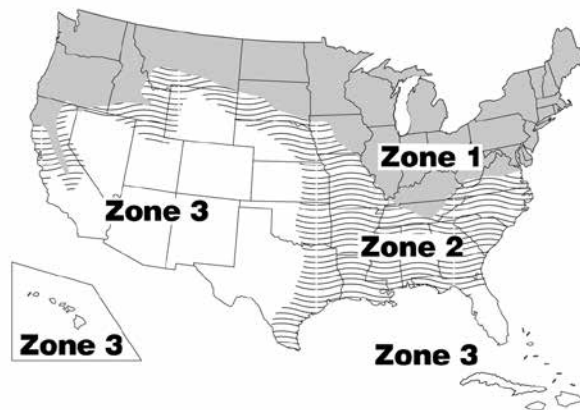

### Step 1

Make sure the power switch is **OFF** before proceeding to the next step.

### Step 2

Select the electrical outlet into which you will plug the transformer. Measure the distance from this outlet to the control box following the path where the wire will be laid. After you have measured how much wire is needed, cut the wire to the appropriate length.

## IMPORTANT INFORMATION ABOUT LOW VOLTAGE WIRE

The only wire acceptable for use with GTO products is 16 gauge stranded, low voltage, PVC sheathed wire. This particular gauge enables the transformer to provide an adequate charge through the control board to the battery at distances up to 1000 ft.

**DO NOT** use telephone wire or solid core wire. Unlike stranded wire, these types of wire are not appropriate for use with your gate opener system.

**AVOID** splicing wires together. Splicing permits corrosion and seriously degrades the wire's ability to carry an adequate current.

### Step 3

Lay the measured length of low voltage wire in a trench following a path from the selected electrical outlet to the control box. Wires coming up from the ground should be run through PVC conduit to protect them from lawn mower blades, weed eaters, and grazing animals. Be sure to bury the wire laid in the trench.

### Step 4

Feed the low voltage wires upward through the strain relief opening on the lower left of the control box. Pull 6" to 8" of wire into the control box and tighten the strain relief screw to secure the wires.

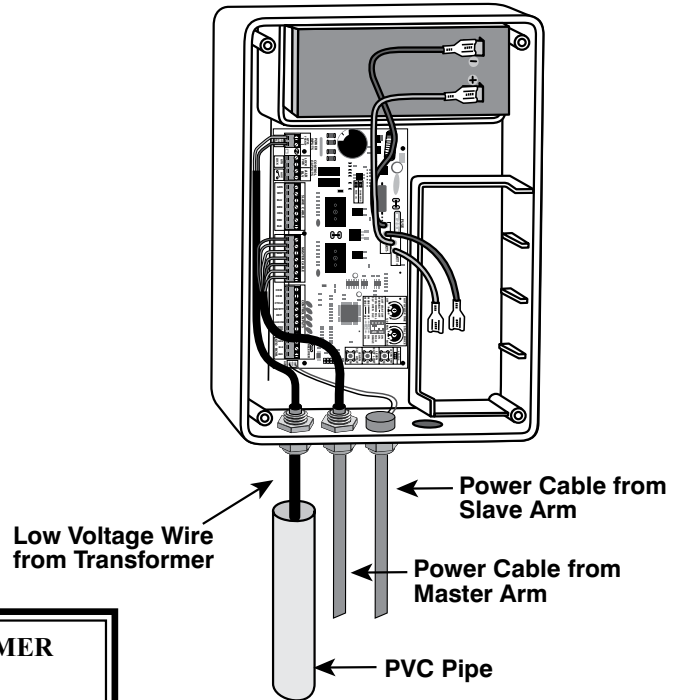

**⚠ WARNING! DO NOT PLUG THE TRANSFORMER INTO AN OUTLET DURING THIS STEP! THE TRANSFORMER MUST ONLY BE PLUGGED INTO AN OUTLET DURING STEP 7!**

### Step 5

Strip  $\frac{3}{16}$ " off the ends of the low voltage wire and twist tightly. Attach these ends to the 18VAC terminals located on the **POWER IN** terminal block (see illustration at right). **Be certain not to let the exposed wires touch each other!**

Insert one transformer wire into an 18VAC terminal. Insert the other transformer wire into the remaining 18VAC terminal. The transformer wires can be connected to the 18VAC terminals regardless of polarity or color.

Tighten set screws against exposed end of wires.

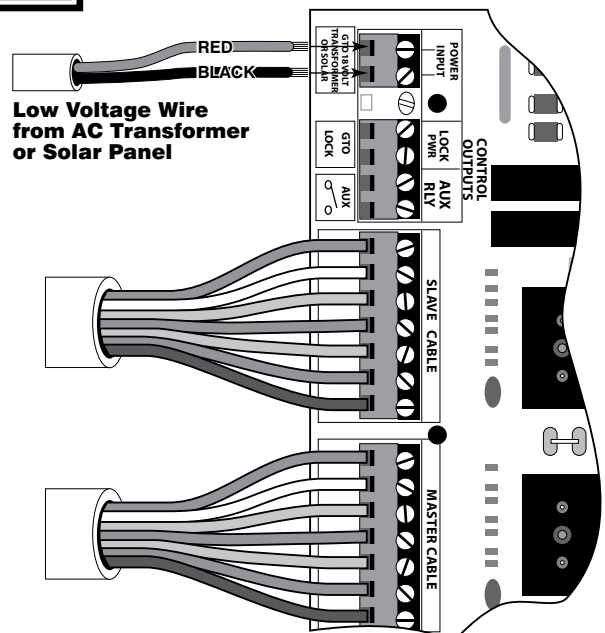

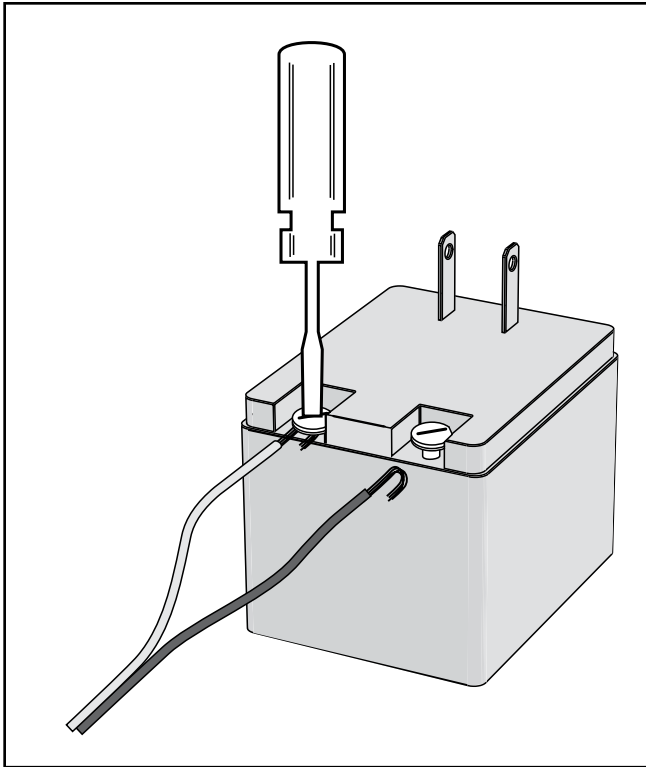

## Step 6

Strip 1/2" of insulation from the ends of the low voltage wire. Attach these stripped ends to the transformer terminals.

A dab of household petroleum jelly on each terminal will help prevent corrosion.

**Make sure the exposed wires do not touch each other!**

## Step 7

Plug the transformer into the electrical outlet.  
(Use of a surge protector with the transformer is strongly recommended.)

**HINT:** Keep a few mothballs in the control box to discourage insects from entering it and damaging the control board.

**NOTE:** If transformer will be located outside be sure to enclose in a weatherproof cover (not included).

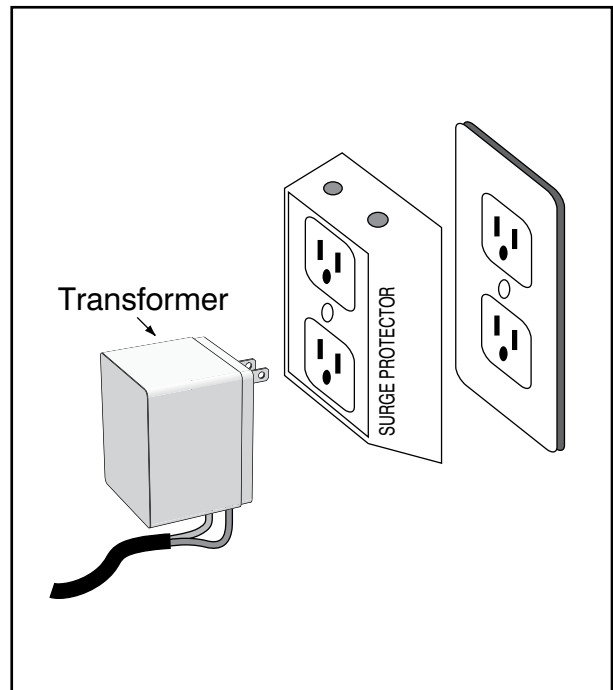

# CONTROL BOARD SETTINGS

## DIP Switches

### DIP Switch Settings (MODES)

#### DIP Switch #1 - Soft Start/Stop

**ON** - Soft start enabled (factory preset).

**OFF** - Soft start disabled.

The Soft Start/Stop feature slowly starts the gate as it begins to open and slows the gate as it comes to the closed position. This saves wear and tear on the gate and gate opener system.

#### DIP Switch #2 - Warning Buzzer

**ON** - Buzzer warning enabled (factory preset).

**OFF** - Buzzer warning disabled.

The Warning Buzzer alerts you when the gate opener is beginning to either open or close the gate. It sounds for the first 2 seconds in each direction. It also sounds a warning when the gate obstructs two times in one cycle. Switching this to OFF disables the open and close warning not the obstruction warning.

#### DIP Switch #3 - Push/Pull-to-Open

**ON** - Push to open.

**OFF** - Pull to open (factory preset).

If your gate opens into the property the DIP Switch is set to the OFF position (factory setting). If your gate opens out from the property the DIP Switch must be set to the ON position. NOTE: if you have a Push-to-Open gate application you will need a Push-to-Open bracket (see Push-to-Open Instructions on page 30).

#### DIP Switch #4 - Delay/Simultaneous operation

**ON** - Second opens simultaneously with master.

**OFF** - Second opens after master (factory preset).

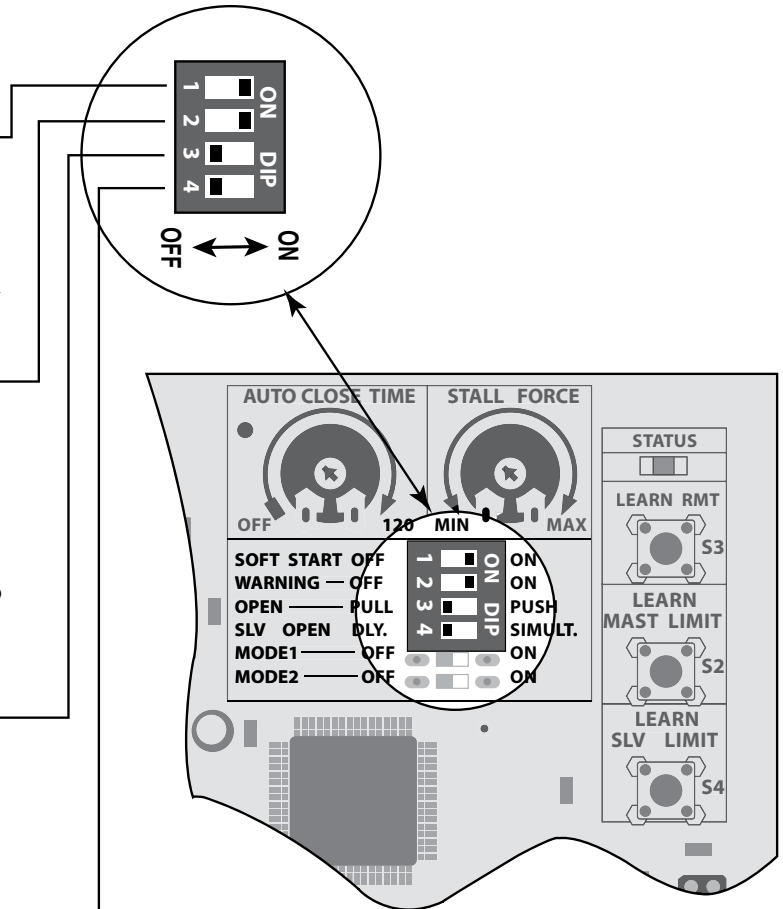

## Auto Close

The 'AUTO CLOSE TIME' pot controls auto close feature.

Turning the pot all the way counter-clockwise will turn auto close feature off. The minimum time is 3 seconds. The maximum (turn the pot all the way clockwise) time is 120 seconds.

Auto Close Time Pot

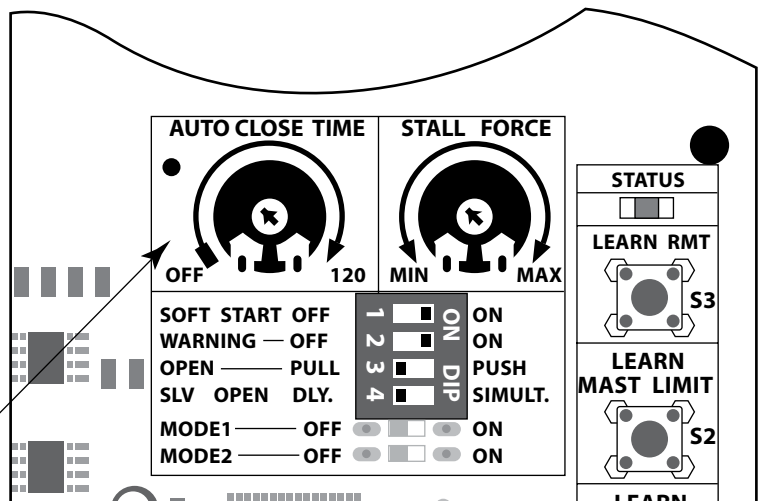

# Setting the Closed Position Limits for Pull to Open Applications

## TURN CONTROL BOX ON

**NOTE:** The OPEN limit is when the opener is fully retracted and the gate is in the full open position. The open limit setting can only be adjusted by moving the gate bracket. To achieve the optimum closed position, you must adjust the CLOSED limit setting:

### Step 1

Confirm that the power switch is in the ON position, and the gates are in the OPEN POSITIONS.

### Step 2

Activate your openers by pressing the entry transmitter button. Your gates should now be moving from the fully open positions toward their closing position. Prepare to STOP gate that reaches the desired closed position first by pressing the entry transmitter button again. This step may be repeated until desired close position is achieved. Once the desired CLOSED position has been achieved, proceed to step 3.

### Step 3

Note which gate has reached the desired closed position (typically it's the Second gate), program the closed limit setting by pressing and holding the corresponding 'LEARN MAST LIMIT' or 'LEARN 2ND LIMIT' for 5 seconds.

### Step 4

Press the transmitter button and allow the gates to return to the fully open position. YOUR FIRST GATE'S CLOSED POSITION LIMIT IS NOW PROGRAMMED.

### Step 5

Activate your openers again by pressing the entry transmitter button. Your gates should now be moving from the fully open positions toward their closing position. The gate programmed in Step 4 will stop at the spot you just programmed and the other gate will continue to close until you press the transmitter button again. The optimum CLOSED POSITION for the second gate is when it closes firmly, without excess tension, against the first gate. This step may be repeated until desired close position is achieved. Once the desired CLOSED position has been achieved, proceed to step 6.

### Step 6

Repeat step 3 for the other gate that has not been set in step 3.

### Step 7

Press the transmitter button and allow the gates to return to the fully open position. BOTH YOUR MASTER AND SECOND GATE'S CLOSED POSITION LIMITS ARE NOW PROGRAMMED.

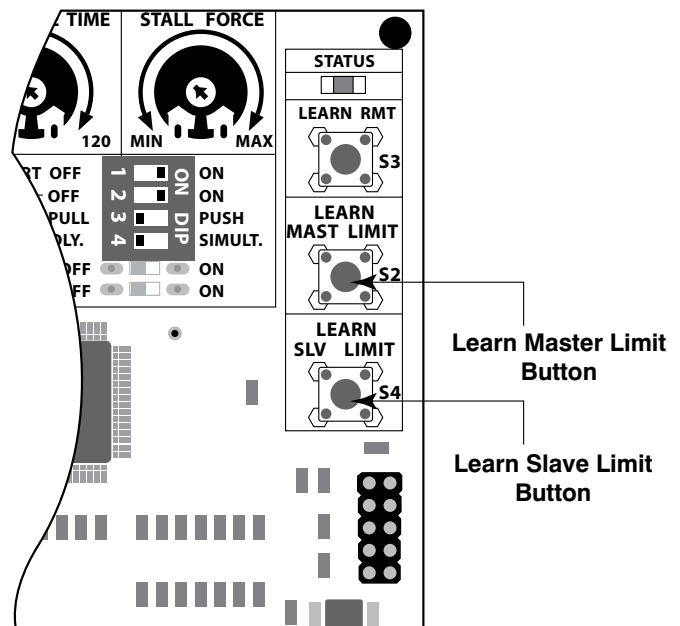

## TESTING YOUR CLOSED LIMIT SETTING:

Press your entry transmitter and allow your gates to close. If CLOSED positions are not correct or need to be changed, you will need to CLEAR your CLOSED LIMIT settings and follow Steps 1-7 again.

## CLEARING PROGRAMMED CLOSED LIMIT SETTING:

If you make a mistake and set the limit at the wrong position – press your transmitter to return the gates to their fully opened positions, then press and hold the 'LEARN MAST LIMIT' or 'LEARN 2ND LIMIT' button for 5 seconds. This will clear the memory for the closed limit positions. Follow Steps 1-7 again.

# Setting Your Personal Transmitter Code

All GTO transmitters are set to a standard code at the factory and are ready to operate your GTO® Gate Opener®. For your safety and security, however, we **strongly recommend** that you replace the factory setting with your own personal code. Follow the directions below:

## 1. Remove the Transmitter Cover

On the back of the transmitter use a small phillips head screw driver to remove the two screws on the sides of the visor clip and separate the front cover from the transmitter. With the front cover removed, the battery and the DIP switches will be exposed. To set a new code, use a small screwdriver to move the switches.

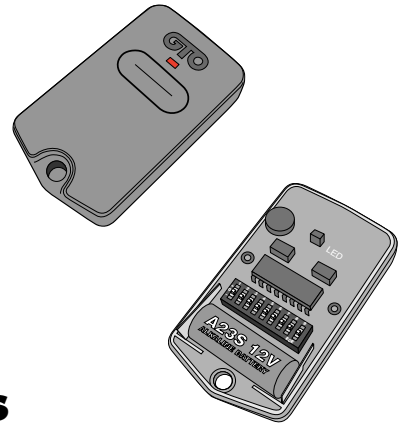

## 2. Set the transmitter DIP Switches

There are nine (9) transmitter DIP switches; each can be placed in three different positions (+, 0, -). **DO NOT** set all the switches in the same position, such as all +, all 0, or all -. Once the DIP switches have been set to a personal code, replace front cover.

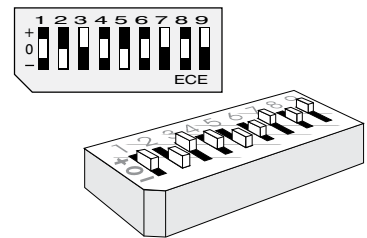

**WARNING:** No other adjustments should be made inside the transmitter.

## 3. "Teach" the New Code to Control Board Memory

- Press and hold transmitter button.
- Press and hold the **LEARN RMT (Learn Remote)** button on the control board until the buzzer sounds.
- Release transmitter button. The new code is stored in control board memory.
- Release the **LEARN RMT (Learn Remote)** button.

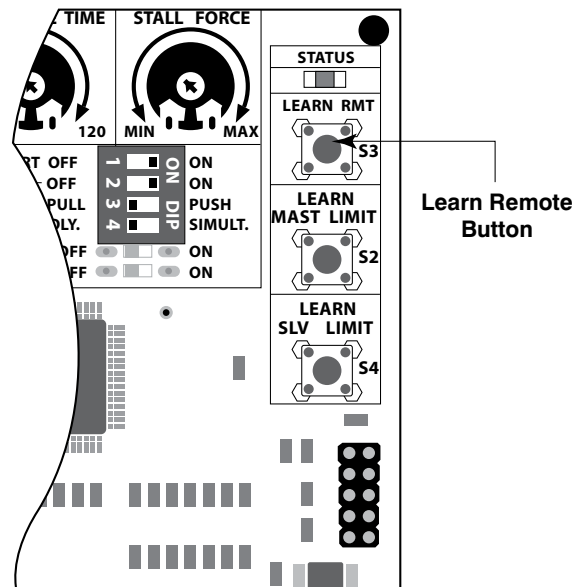

# Obstruction Sensitivity Potentiometer

**IMPORTANT:** For safety reasons the obstruction setting or **Stall Force** on the GTO® gate opener control board comes from the factory set at **MIN** (minimum). In many gate installations this setting will need to be adjusted to overcome the weight and size of the gates.

The **Stall Force** potentiometer on the control board operates like a volume control on a radio. It controls the obstruction sensitivity (or the amount of force the opener will apply to an obstruction) before it automatically stops and reverses direction for approximately two (2) seconds.

Use a small flat blade screwdriver to turn the arrow in the center of the potentiometer. Adjust the sensitivity from the **MINIMUM** position where the gate operates without obstructing from its own weight or the wind conditions in your area.

**NOTE:** You may need to increase the stall force in cold weather due to increased resistance from gate hinges.

**ALWAYS KEEP SAFETY AT THE TOP OF YOUR LIST WHEN ADJUSTING OR SERVICING YOUR AUTOMATIC GATE OPENER!**

## Installing the Receiver

Use the transmitter to check the range of the receiver *before permanently mounting it*.

Consider the following when mounting the receiver:

- Standard receiver cable length is 10 feet (receivers with a longer cable are available as special order items; *call the GTO Sales Department*). NEVER splice receiver cable!
- **Run the cable through PVC conduit to protect it from damage.**
- DO NOT run cable in conduit containing ac wiring.
- DO NOT mount receiver on a metal fence or post; doing so will decrease signal range.
- The receiver range can vary from 50 to 100 feet depending upon weather, topography, and external interference.
- DO NOT mount upside down.
- MOUNT so that you have line of sight between remote and antenna.
- MOUNT 3 feet away from AC voltage.
- MOUNT as high as possible for optimum range.

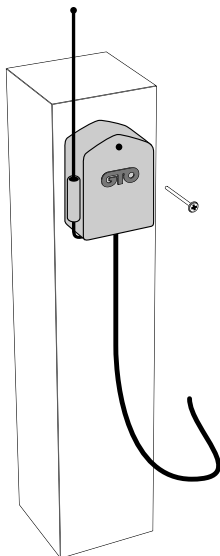

### FCC Regulation

This device complies with FCC rules Part 15. Operation is subject to the following conditions:

1. This device may not cause harmful interference.
2. This device must accept an interference that may cause undesired operation.

Transmitter distance may vary due to circumstances beyond our control. **NOTE:** The manufacturer is not responsible for any radio or TV interference caused by unauthorized modifications to this equipment. Such modifications could void the user's authority to operate the equipment.

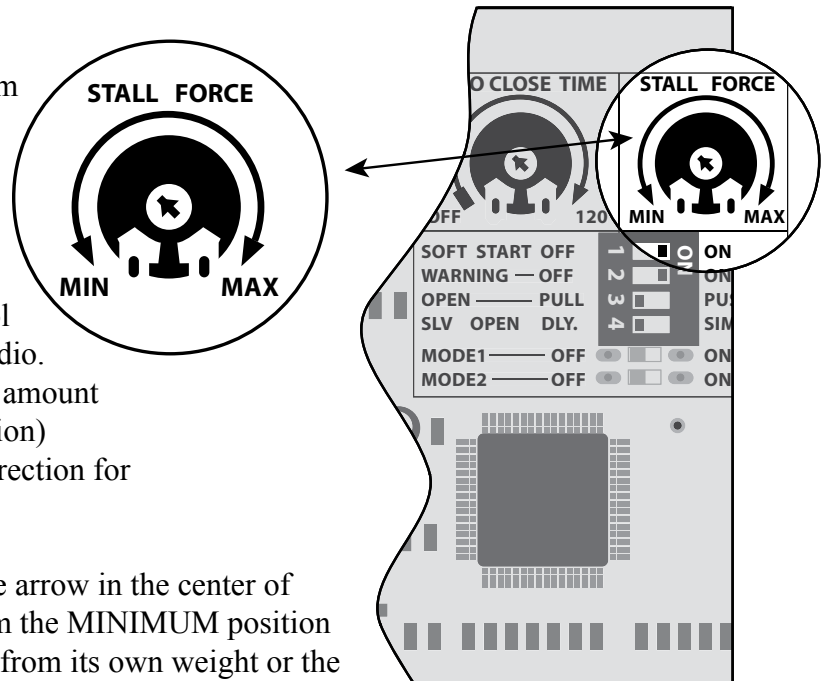

# Connecting Accessories

## Input Connections

- All control inputs are dry-contact, normally open, inputs. DO NOT apply external voltage sources to these inputs.
- All inputs are connected with respect to COMMON terminal.
- The status LED will blink once when any input is activated.

**1 COM:** Circuit common (reference for all logic input)

- Two (2) terminals to provide extra common connection point.

**2 CYCLE/CLOSE:** (Typically for use with push button or hard-wired keypad)

- Each activation at this input will cycle the operation as follows:  
OPEN–STOP–CLOSE–STOP–OPEN

**3 SAFETY:** (Typically for use with photo beam device, loop detector or other non-contact sensors)

- Activation of this input while the gate is closing will cause the gate to stop and return to the opened position.
- Activation of this input while the gate is opening has no effect (gate will continue to open).
- Activation of this input while gate is idle will prevent gate from closing.

**4 EXIT/OPEN:** (Typically for use with exit loop or wand)

- Activation of this input will open the gate if it's not already at the open position
- Activation of this input while at open limit will restart the auto close time (if enabled).

**5 SHADOW LOOP:** (Typically for use with loop detector)

- This input is only monitored when the gate is at the fully open position. At any other position, activation of this input has no effect on gate operation.
- Activation of this input while gate at the fully open position will prevent gate from closing.

**6 CLOSE EDGE:** (Typically for use with safety edge device)

- Activation of this input while the gate is closing will cause the gate to stop and reverse direction for approximately 2 seconds.
- Activation of this input while the gate is opening has no effect (gate will continue to open).
- Activation of this input while gate is idle will prevent gate from closing.

**7 OPEN EDGE:** (Typically for use with safety edge device)

- Activation of this input while the gate is opening will cause the gate to stop and reverse direction for approximately 2 seconds.
- Activation of this input while the gate is closing has no effect (gate will continue to close).
- Activation of this input while gate is idle will prevent gate from opening.

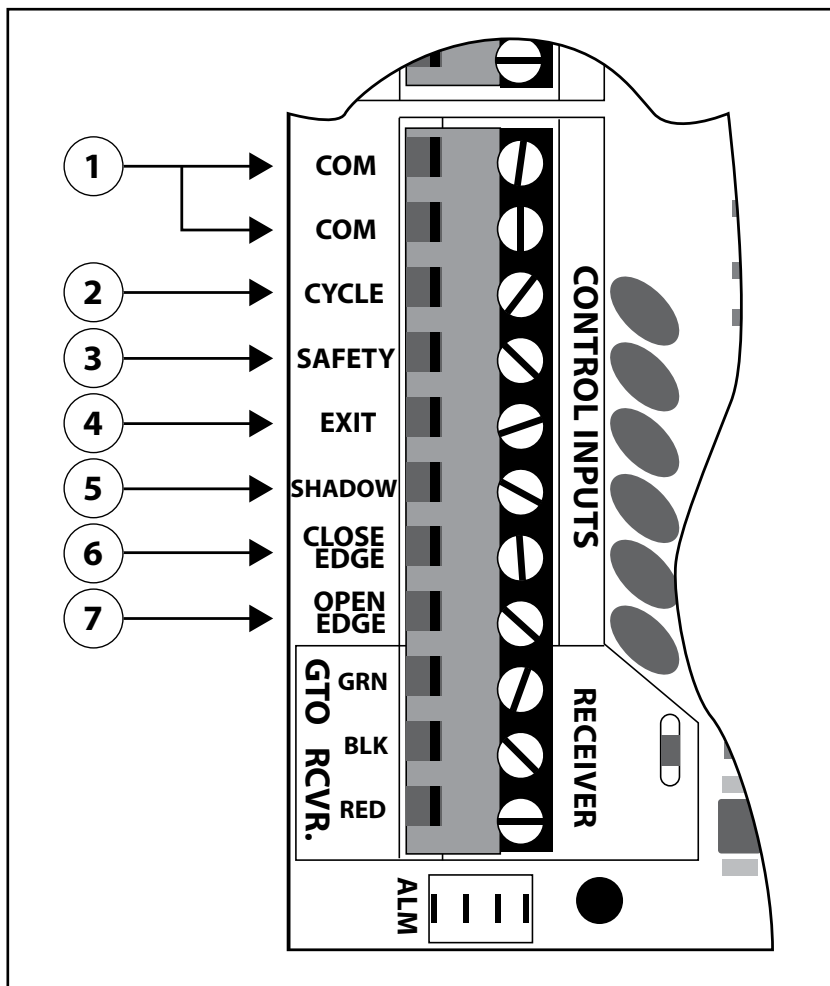



# Wiring Accessories

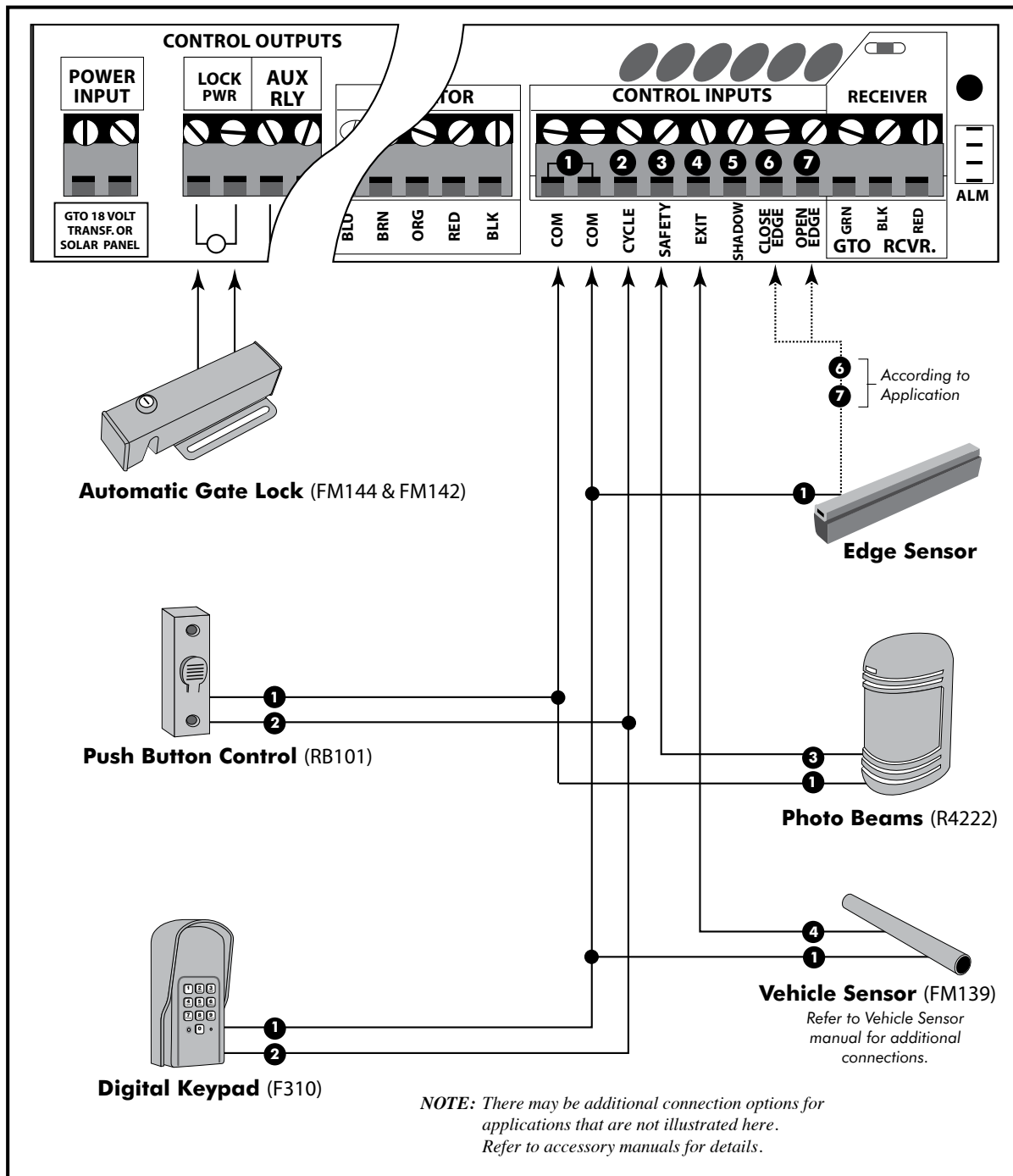

## Connecting Other Auxiliary Devices (Sirens, Lights, etc.)

- These 2 terminals are normally open “dry-contact” (no voltage) relay output.
- Relay is closed when the gate is in motion; Relay is open when the gate is not in motion.
- These 2 terminals maximum rating is 24Vdc, 1 Amp.

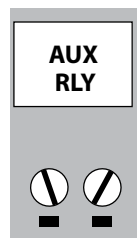

# Push to Open Installation

## Determining The Mounting Position of The Post Bracket Assembly

**⚠** Swinging gates shall not open into public access areas!

A "Push-to-Open" gate opens *out* from the property. A **Push-to-Open Bracket** is required for this type of installation (see *Accessory Catalog*). If you have a pull-to-open gate (gate opens *into* the property), return to page 13; step 3.

In a PUSH-TO-OPEN installation the openers are installed while the gates are in the **closed** position.

### Step 1

With the gates **closed**, adjust the post bracket assembly and the gate bracket until the opener is level. While holding the opener level, use C-clamps to temporarily keep the post bracket assembly and gate bracket in their respective positions on the fence post and gate.

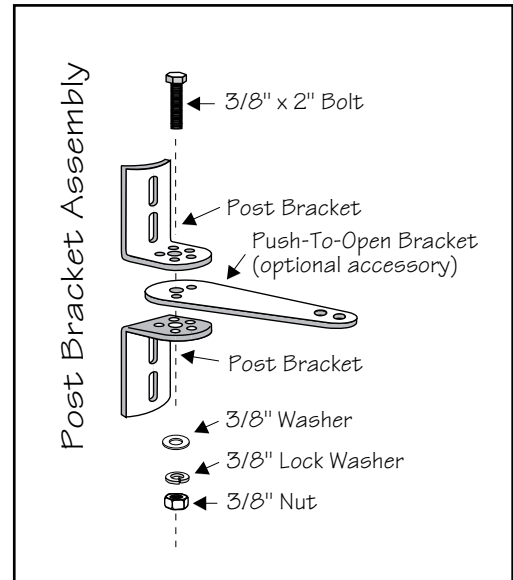

**IMPORTANT:** While determining the mounting point for the post pivot bracket assembly be sure that the position allows for maximum clearance between the gate and the opener in both the open and closed positions, as shown in the diagrams below. This clearance will give the opener the most efficient leverage point for opening and closing the gate and more importantly provides the least possible pinch area.

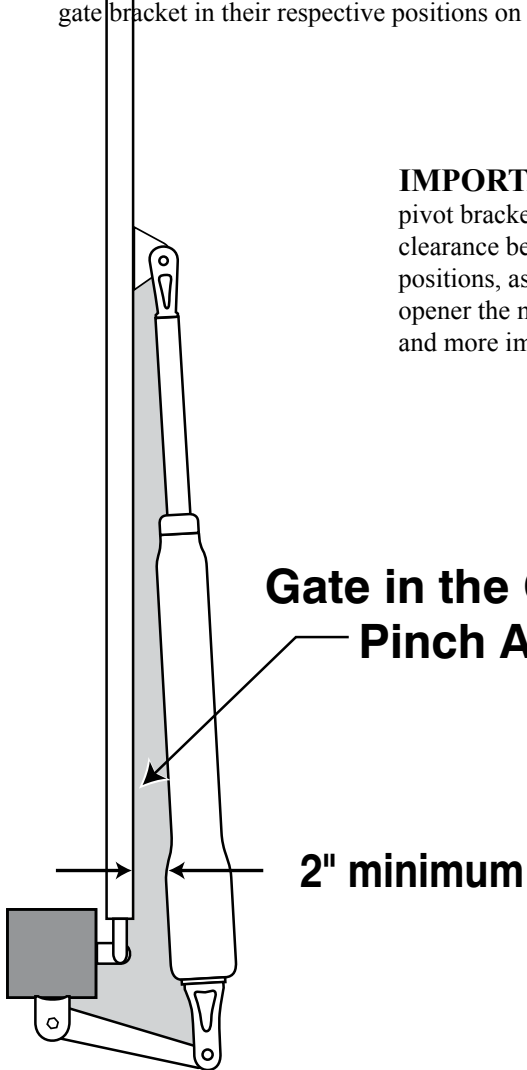

### Step 2

After verifying that you have the best position for the post pivot bracket, insert the  $\frac{5}{16}$ " x  $1 \frac{3}{4}$ " bolt through the aligned holes of the post bracket and post pivot bracket and fasten it with the  $\frac{5}{16}$ " washer and nut.

**IMPORTANT:** If you loosened the clamp on the post bracket to achieve the optimum position, tighten it in its new position and recheck the gate bracket with the gate in the open position (move the gate bracket and re-clamp it if necessary).



\*The Troubleshooting Wizard has detailed information on Push-To-Open installations.

### Step 3

With the gate in the **fully closed position** and the opener retracted, swing the opener to the gate. Mark reference points for bolt holes on gate cross member through middle of gate bracket slots. The opener must be level. (Some vertical adjustment is possible by sliding the post bracket assembly up and down.) Drill  $\frac{3}{8}$ " holes into the gate cross member as marked. Fasten gate bracket to cross member using (2)  $\frac{3}{8}$ " x 3" bolts, washers, lock washers, and nuts. Attach the opener to the post bracket assembly and gate bracket using clevis pins, bushings, and hairpins clips.

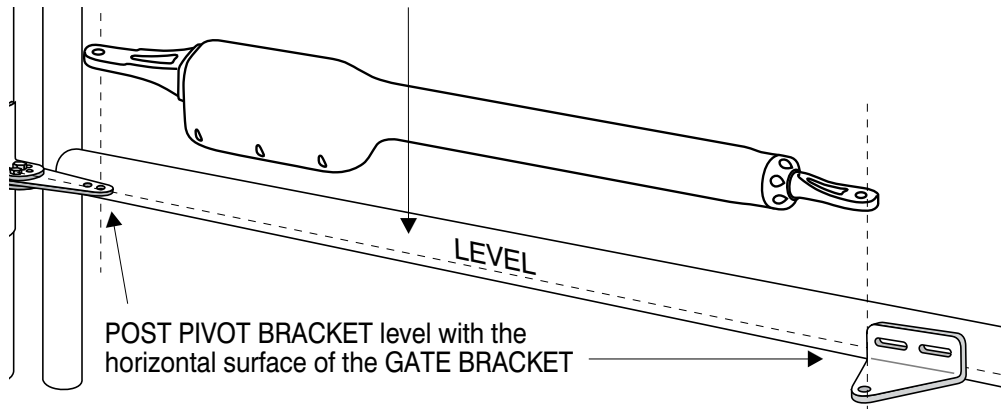

### Step 4

Make sure the control box power switch is **OFF**. Use a small screwdriver to move the **Number 3** DIP switch from the factory setting (OFF / Pull-To-Open) to **ON for Push-To-Open**. Turn power switch **ON**. The control board is now configured to *push* the gate open.

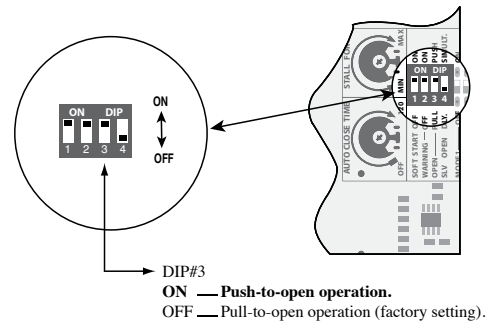

### Step 5

Install the second gate opener on the other gate in the same manner. Then refer to the **CONTROL BOARD SETTINGS** on page 25 for gate sequencing and other programming steps before proceeding.

## Setting the Open Position Limit

### Step 1

Confirm that the power switch is in the ON position, and the gates are in the CLOSED POSITIONS.

### Step 2

Activate your openers by pressing the entry transmitter button. Your gates should now be moving from the closed positions toward their open position. Prepare to **STOP** gates by pressing the entry transmitter button again when the first gate reaches the desired open position. This step may be repeated until desired open position is achieved. Once the desired **OPEN** position has been achieved, proceed to step 3.

### Step 3

Note which gate has reached the desired closed position (typically it's the SECOND gate), program the closed limit setting by pressing and holding the corresponding 'LEARN MAST LIMIT' or 'LEARN 2ND LIMIT' button for 5 seconds.

### Step 4

Press the transmitter button and allow the gates to return to the closed position. YOUR FIRST GATE'S OPEN POSITION LIMIT IS NOW PROGRAMMED.

### Step 5

Activate your openers again by pressing the entry transmitter button. Your gates should now be moving from the closed positions toward their open positions. The first gate will stop at the spot you just programmed and the second gate will continue to open until you press the transmitter button again. Press the transmitter button when the second gate reaches the desired open position. This step may be repeated until the desired OPEN position is achieved. Once the desired OPEN position has been achieved, proceed to step 6.

### Step 6

Repeat step 3 for the other gate that has not been set in step 3.

### Step 7

Press the transmitter button and allow the gates to return to the closed position. BOTH YOUR MASTER AND SECOND GATE'S OPEN POSITION LIMITS ARE NOW PROGRAMMED.

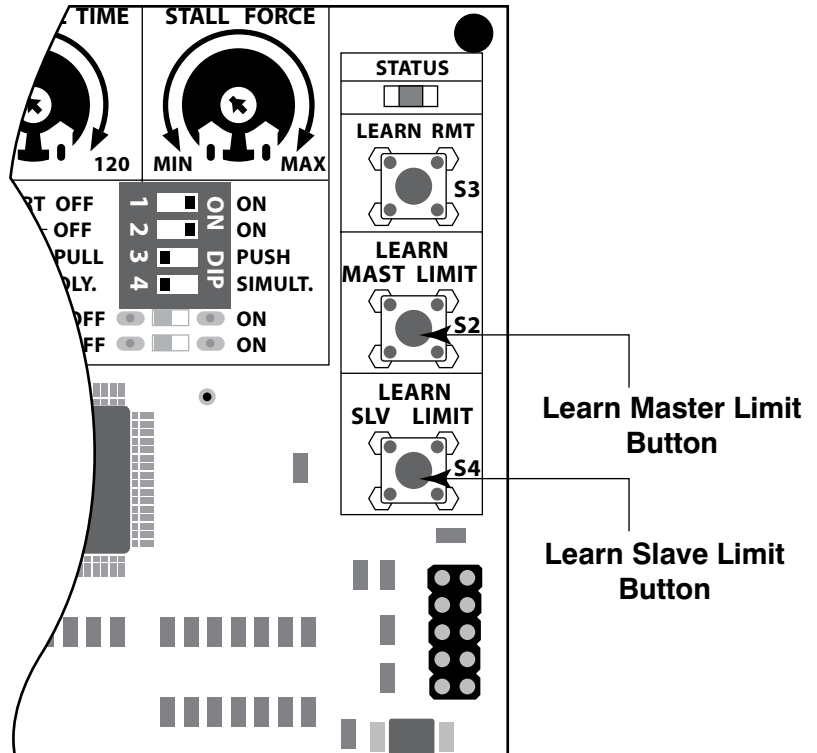

### TESTING YOUR OPEN LIMIT SETTING:

Press your entry transmitter and allow your gates to open. If OPEN positions are not correct or need to be changed, you will need to CLEAR your OPEN LIMIT settings and follow steps one (1) to seven (7) again.

### CLEARING THE PROGRAMMED OPEN LIMIT SETTING:

If you make a mistake and set the limit at the wrong position – press your transmitter to return the gates to their closed positions, then press and hold the 'LEARN MAST LIMIT' or 'LEARN 2ND LIMIT' button for 5 seconds. This will clear the memory for the open limit positions. Follow steps one (1) to seven (7) again.

# Troubleshooting Guide

If your gate opener does not function properly after it is installed, use this guide before calling the GTO Service Department.

## VOLTAGE READINGS

18 Vac Transformer ..... 18.0 to 22.0 Vac, 2200 mA

5 W Solar panel (single) ..... 18.0 to 22.0 Vdc, 300 mA

*\* measure voltage at panel and control box.*

Two 12 V, 7 amp hour Batteries ..... 12.5 to 13.5 Vdc 7.0 Ah

*\*measure voltage at battery terminals with battery disconnected from circuit board*

Charging circuit ..... 13.3 to 14.8 Vdc

*\*measure voltage at battery terminals with battery connected to circuit board and GREEN "POWER IN" LED is ON.*

## Audible Feedback

Indication	Possible Diagnosis	Check
1 short beep upon activation	Blown Fuse Low or Bad Battery Loose Battery Connection	<ul style="list-style-type: none"> <li>• Fuse</li> <li>• Battery Under Load</li> <li>• Battery Harness Connections</li> </ul>
1 short beep upon power up	Circuit Board Powered Up & Ready	<ul style="list-style-type: none"> <li>• Normal Operation</li> </ul>
Continuous Uninterrupted Alarm	Circuit Board Senses an Obstruction	<ul style="list-style-type: none"> <li>• Path of Gate</li> <li>• Gate for Level and Plumb</li> <li>• Stall Force Adjustment</li> <li>• Disconnect Safety Devices</li> <li>• Rev Counter</li> </ul>
1 beep with 10 seconds off	Low Battery Condition	<ul style="list-style-type: none"> <li>• Fuses</li> <li>• Battery Harness Connections</li> <li>• Battery Under Load</li> </ul>
1 beep then 2 beeps	Master Motor Terminals Shorted	<ul style="list-style-type: none"> <li>• Connections to Master Inputs</li> <li>• Master Arm Power Cable</li> <li>• Motor</li> <li>• Circuit Board</li> </ul>
1 beep then 3 beeps	Second Motor Terminals Shorted	<ul style="list-style-type: none"> <li>• Connections to Second Inputs</li> <li>• Second Arm Power Cable</li> <li>• Motor</li> <li>• Circuit Board</li> </ul>
1 beep with 2 seconds off	Master Arm Limit Switch Error	<ul style="list-style-type: none"> <li>• Connections to Master Inputs</li> <li>• Master Arm Power Cable</li> </ul>
2 beeps with 2 seconds off	Second Arm Limit Switch Error	<ul style="list-style-type: none"> <li>• Connections to Second Inputs</li> <li>• Second Arm Power Cable</li> </ul>
3 beeps with 2 seconds off	Master Arm Rev Counter Error	<ul style="list-style-type: none"> <li>• Connections to Master Inputs</li> <li>• Master Arm Power Cable</li> <li>• Rev Counter</li> </ul>
4 beeps with 2 seconds off	Second Arm Rev Counter Error	<ul style="list-style-type: none"> <li>• Connections to Second Inputs</li> <li>• Second Arm Power Cable</li> <li>• Rev Counter</li> </ul>

# Visual Feedback

Indication	Possible Diagnosis	Check
Status (clear) 1 blink	Cycle Terminal Shorted	Disconnect the push button, keypad, intercom keypad, or any other accessory wired to this terminal. Try the remote. If the remote works, then the problem is the accessory.
Status (clear) 2 blinks	Safety Terminal Shorted	Disconnect the loop detector, photo beam, or any other accessory wired to this terminal. Try the remote. If the remote works, the problem is the accessory.
Status (clear) 3 blinks	Exit Terminal Shorted	Disconnect exit wand, loop detector, photo beam, Knox box, or any other accessory wired to this terminal. Try remote. If the remote works, the problem is the accessory.
Status (clear) 4 blinks	Shadow Terminal Shorted	Disconnect the loop detector, photo beam, or any other accessory wired to this terminal. Try remote. If the remote works, the problem is the accessory.
Status (clear) 5 blinks	Close Edge Terminal Shorted	Disconnect the edge sensor, photo beam, or any other accessory wired to this terminal. Try the remote. If the remote works, the problem is the accessory.
Status (clear) 6 blinks	Open Edge Terminal Shorted	Disconnect edge sensor, photo beam, or any other accessory wired to this terminal. Try the remote. If the remote works, the problem is the accessory.
RF (yellow) Flickers	Receiving 318 MHz RF	Normal operation when remote or wireless keypad is used.
RF (yellow) OFF	No 318 MHz RF Received	<ul style="list-style-type: none"> <li>• Battery in Remote</li> <li>• Program Remote</li> <li>• Antenna Receiver Connections</li> <li>• Antenna Receiver</li> </ul>
Power (green) ON	AC or Solar Power Present	Normal Operation
Power (green) OFF	No AC or Solar Power	<p><b>Transformer:</b></p> <ul style="list-style-type: none"> <li>• Breaker or GFI</li> <li>• Power at AC outlet.</li> <li>• Output of Transformer.</li> <li>• Voltage on wire at 18 VAC Input</li> </ul> <p><b>Solar:</b></p> <ul style="list-style-type: none"> <li>• Weather</li> <li>• Solar Panel Placement</li> <li>• Output of Solar Panel</li> <li>• Voltage on wire at Solar Input</li> </ul>
Charge (red) ON	Fast Charging Mode	Battery Voltage should be ~ slowly increasing
Charge (red) Fast Blinking 2/second	Soak Charging Mode	Battery Voltage should be ~14.1 VDC
Charge (red) Slow Blinking 2/second	Float Charge	Battery Voltage should be ~13.8 VDC
Charge (red) OFF	Battery Not Being Charged	AC power Transformer Solar Panel Charging Circuit

## Battery/Power Troubleshooting

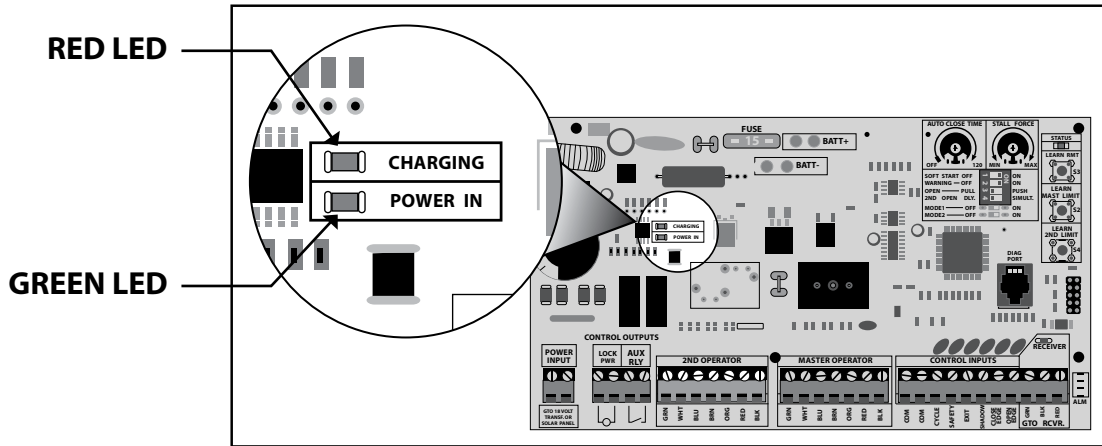

POWER IN LED	CHARGING LED	
ON	Steady ON	Battery Charging
ON	Blinking	Battery Fully Charged
ON	OFF	Bad Charger
OFF	OFF	No AC/Solar Power
OFF	Blinking	Low Battery
OFF	Steady ON	Bad Charger

# Repair Service

If your Gate Operator is not operating properly, please follow the steps below:

1. First use the procedures found in the Troubleshooting Guide (see page 25).
2. Use the 24/7 Troubleshooting Wizard at <http://support.gtoinc.com>.
3. If you are unable to solve the problem, call the GTO Service Department at (800) 543-1236, or (850) 575-4144. Refer to the serial number (located on the right side of the control box) and date of purchase when calling for assistance.
4. If repair or replacement of your gate operator is necessary, the Service Department will assign a Return Goods Authorization (RGA) number to you.
5. Securely pack the component(s) authorized for return to the factory. Include a copy of your sales receipt for the purchase of the product(s). Write the RGA number issued to you on the outside of the package in **LARGE BOLD PRINT**.

Ship the package(s) freight prepaid to: GTO, 3121 Hartsfield Road, Tallahassee, Florida, USA 32303.

**NOTE: Products returned to GTO without a Return Goods Authorization (RGA) number in LARGE BOLD PRINT on the outside of the package WILL NOT be accepted. Also, items returned to GTO freight collect WILL NOT be accepted.**

## GTO Technical Service and Installation Assistance

8:00am–7:00pm • Monday–Friday (EST)

Toll Free Support: 800-543-1236 • Local Support: 850-575-4144 • Fax: 850-575-8950

24/7 Troubleshooting Wizard: <http://support.gtoinc.com>



# Column Installation Information

**IF THIS OPENER WILL BE USED WITH GATES THAT ARE MOUNTED ON MASONRY, BRICK, OR ROCK (etc.) COLUMNS:**

**READ THE FOLLOWING CAREFULLY BEFORE PROCEEDING**

- A. The simplest solution is to install the opener in a push-to-open configuration (requires Push-To-Open Bracket, see Accessory Catalog). The minimum clearance is easier to achieve and clearance is no longer a problem, since the opener will be pushing the gate away from the column instead of pulling it toward the column. It is recommended that you place a steel plate between the opener mounting brackets and masonry surface for additional strength.
- B. If a push-to-open installation is impossible due to traffic hazards, terrain, etc., another option is to re-hang the gate. You may hang it on a post, either in the center of the column or at the back corner, or move the gate to the back corner of the columns.
- C. The most difficult solution is to cut a notch in the column to accommodate the opener and power cable. This job is **NOT** for the inexperienced!

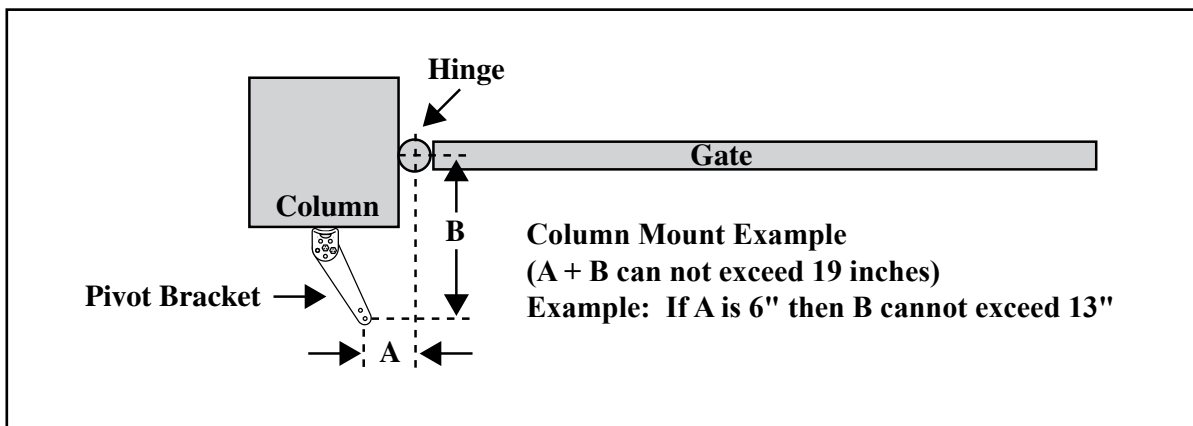

\*The Troubleshooting Wizard has detailed information on column mounting.



# Accessories

Please visit [www.gtoaccess.com](http://www.gtoaccess.com) for photos and detailed descriptions of GTO Accessories. Or call 1-800-543-GATE (4283).

## POWERING ACCESSORIES



### Low Voltage Wire [RB509]

The 16 gauge, stranded, dual conductor low voltage Wire is for connecting the AC powered transformer, solar panel or wired accessories to the system's control board. This specially designed wire is UV treated, PVC coated, and ready for direct burial.

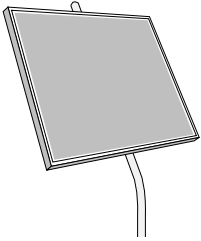

### Solar Panel Kits [FM122/FM123]

If your gate operator is more than 1000 ft. away from an AC power outlet, you can choose to maintain the battery charge with the GTO Solar Panel Kit.

- 10 Watt Solar Panel Charging Kit [FM123]
- 5 Watt Solar Panel Charging Kit [FM122]

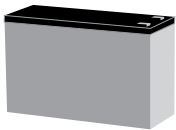

### Additional/Replacement Battery [RB500]

For additional battery power or replacement.

## "FROM VEHICLE" ENTRY AND EXIT ACCESSORIES

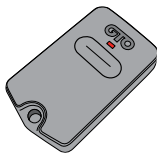

### Transmitters [RB741/RB742/RB743]

Purchase an additional transmitter for each vehicle in your family. The Two-Button Transmitter can be programmed to operate both your gate operator and a garage door opener using the Universal Receiver. Or it can be programmed to open two gate operator systems.



- Single Button Transmitter [RB741]
- Dual Button Transmitter [RB742]
- Three Button Transmitter [RB743]

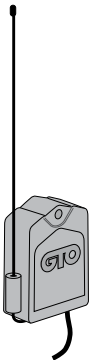

### Universal Receiver [RB709U-NB]

The Universal Antenna Receiver gives you the ability to use one remote to activate your gate operator and your garage door opener. Connects to any brand garage door opener. Up to 100 ft. range.

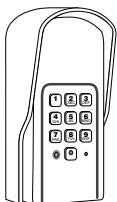

### Digital Keypad [F310]

Allow friends access to your property using an identification code that you provide. Program up to 25 entry codes for added security. Powered by three "AA" batteries (not included).

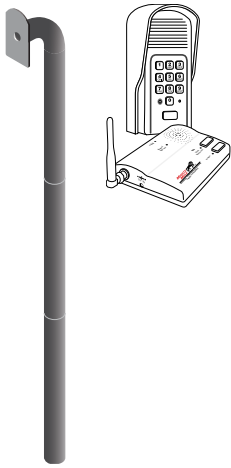

### **Residential Wireless Entry Intercom [FM136]**

Designed for added security to your automated gate with the ability to “speak to” and “screen” visitors safely from inside your home. Ideal for securing gate entrances while providing controlled access.

### **Gooseneck Pedestal [F100/F110]**

Designed to mount digital keypads, wireless intercom systems, and other access control devices for your gate automation system.

## **“HANDS FREE” Entry & Exit Accessories**

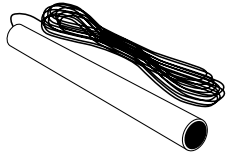

### **Driveway Vehicle Sensor [FM139]**

Automatically activates gate operator “Hands-Free” when a vehicle exits the property. Electromagnetic sensor detects vehicles in motion.

- 50 ft. [FM139]
- 100 ft. [FM140]
- 150 ft. [FM141]

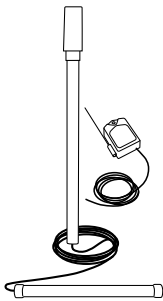

### **Wireless Vehicle Sensor [R4500]**

Automatically activates gate operator “Hands-Free” when a vehicle exits the property. 100 ft. range between transmitter and receiver. Easy installation.

## **LOCKING & SECURITY Accessories**

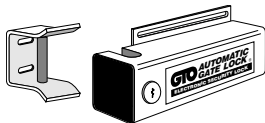

### **Automatic Gate Lock [FM144/FM142]**

The #1 Accessory For Swing Gate Operators! Designed for added security in conjunction with GTO Automatic Gate Operators. The gate lock unlocks and locks automatically when the gate opens and closes. The perfect solution for high wind conditions.

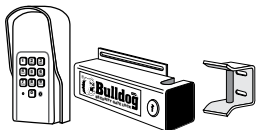

### **Bulldog Pedestrian Gate Lock [FM145]**

Designed to mount on horizontal swing “walk through” wood, chain link, and metal pedestrian gates opening in or out. Ideal for securing pools, condominiums, schools and any pedestrian gate.

### **Wireless Driveway Alarm [R4450].**

This device alerts you of vehicles entering your driveway (with or without an automated gate). The indoor base station signals you with a door chime when a vehicle passes the driveway sensor.

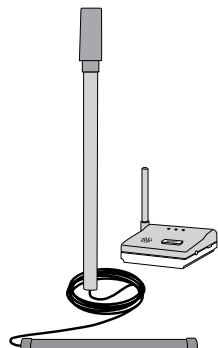

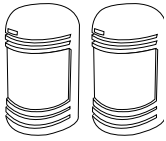

## ADDITIONAL Accessories

### Photo Beams [R4222]

Primary “through beam” photo beam device. Provides “non-contact” entrapment protection.

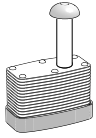

### Pin Lock [FM345]

Use as a substitute for the clevis pin at the front mount of the gate operator to prevent theft of the operator.

- Pin Lock 10-pack: ten Pin Locks keyed alike [FM345KA].



### Push Button Control [RB101]

Wire this unlit push button directly to your gate operator for simple open/close/stop operation from up to 1000 ft. away. Use 16 gauge low-voltage wire.

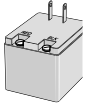

### Replacement Transformer [RB570]

Standard 18 volt, 2200 mA AC transformer included with the gate operator to maintain battery charge.

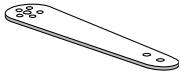

## HARDWARE Accessories

### Push To Open Brackets [347IH]

Required when the gate operator must push a gate open (arm extends to open), such as away from a sloping driveway or where space prevents gate from opening into the property (pull to open). Order two brackets for a dual swing gate installation.



### Column Mount Lock Receiver [433IH]

For use with the Automatic Gate Lock or Bulldog Pedestrian Gate Lock when mounting on brick columns or applications with limited space.

**If you have a question about any special order item,  
just call 1-800-543-GATE!**

The contents of all material available on this installation manual are copyrighted by GTO Access Systems, LLC (“GTO”), unless otherwise indicated. All rights are reserved by GTO, and content may not be reproduced, downloaded, disseminated, published, or transferred in any form or by any means, except with the prior, written permission of GTO. Any reprinting of GTO publications is by permission only. Copyright infringement is a violation of federal law.

Mighty Mule®, E-Z Gate®, GTO®, are registered trademarks of GTO Access Systems, LLC America’s DIY Automatic Gate Openers is a trademark of GTO and are the exclusive property of GTO Access Systems, LLC.

All rights are reserved by GTO, and these marks may not be used, in any for without the prior, written permission of GTO.



**3121 Hartsfield Road • Tallahassee, Florida, USA 32303**

**800-543-4283 • Fax (850) 575-8912**

**Web site [www.gtoaccess.com](http://www.gtoaccess.com)**



**24/7 Troubleshooting Wizard: <http://support.gtoinc.com>**