

# FM231



## Vehicle Detection Alarm

### INSTALLATION MANUAL



### Kit Includes:

- A. Transmitter
- B. Sensor
- C. Receiver
- D. Transformer
- E. Mounting post (3 pcs)

### How It Works:

The electromagnetic sensor detects vehicles in motion and sends a signal to the indoor receiver. The indoor receiver will chime when it receives the signal.

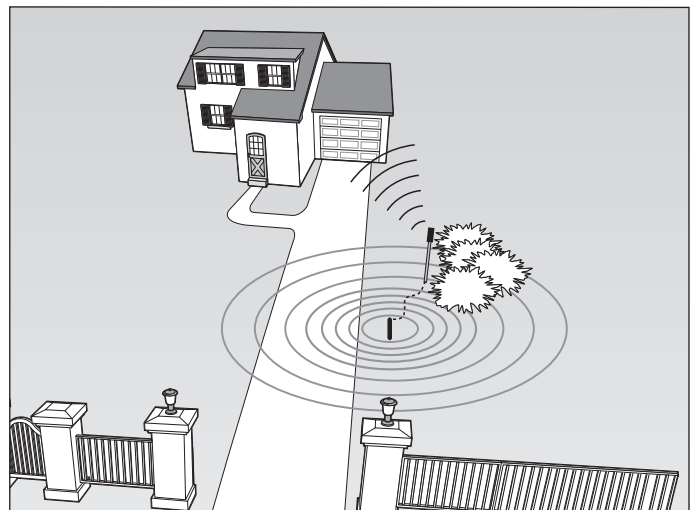

# Installation Overview

The SENSOR should be buried immediately next to the driveway to maximize the sensing range, but at least 25 feet from roadways, neighbor's driveways or large moving metal objects.

The cable connecting the SENSOR and TRANSMITTER allows for the placement of the TRANSMITTER away from the driveway in the concealment of landscape or closer to the RECEIVER.

The approximate maximum transmitting range from the TRANSMITTER to the RECEIVER is 400 ft. Range can vary depending on environmental conditions such as RF interference and topography. Some adjustment may be required.

**NOTE: DO NOT place the TRANSMITTER in the direct path of a sprinkler. The TRANSMITTER is water resistant but not waterproof.**

**If you don't use the full length of signal cable from the SENSOR to the TRANSMITTER, coil the extra cable and bury it beside the transmitter stake.**

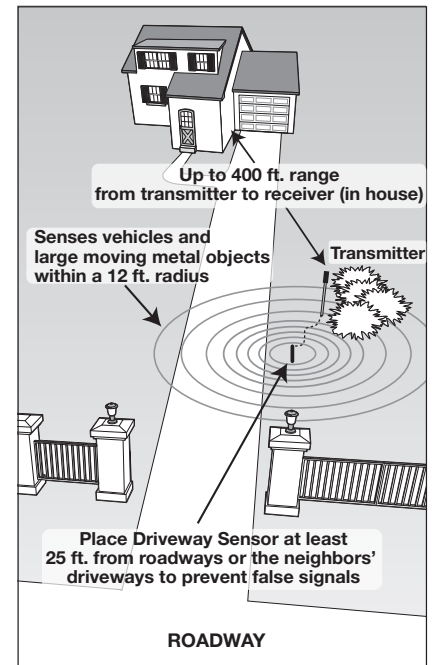

# Sensor Placement

## Determining Sensor Location

**IMPORTANT:** Clear an area 25 ft. in all directions of metal tools, toys and automobiles, to prevent magnetic disturbance during testing and installation.

- Determine the optimum location for the SENSOR using the information found in "Installation Overview."
- Dig a hole approximately 1 ft. deep and 1 ft. long within 2 ft. and parallel to the edge of the driveway.
- Place the SENSOR flat in the hole and parallel to the driveway.
- Keep the SENSOR and the cable uncovered at this time.

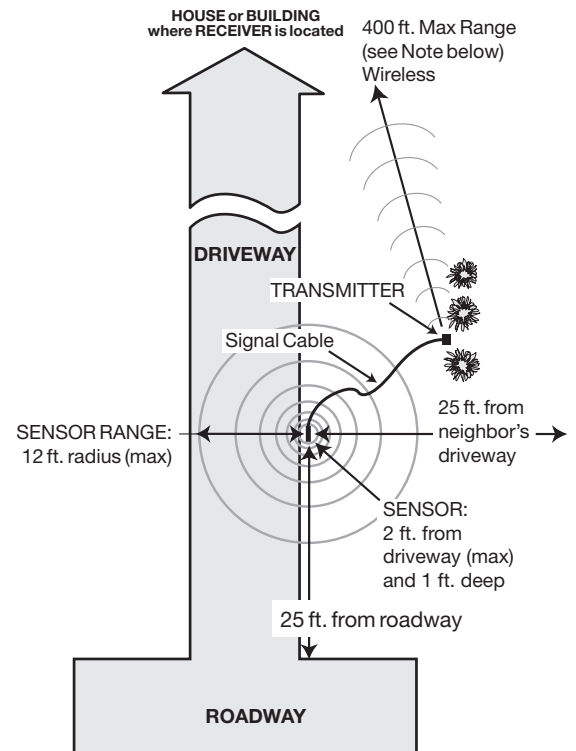

## Notes For Optimum Performance:

- Install the SENSOR as far as possible away from power transformers, power lines, underground gas line, and telephone lines.
- Install the SENSOR away from general moving traffic to prevent unwanted activation. Remember that the SENSOR detects MAGNETIC DISTURBANCES caused by a vehicle's mass and velocity.
- Range distance is approximate and will vary due to outside interference, type of soil, vehicle mass, speed, etc.
- It is recommended that you run the Sensor Cable inside PVC conduit to prevent accidental damage.
- Do not run the Sensor Cable in conduit with other wires such as AC power or other control wires.
- The SENSOR CABLE CANNOT BE SPLICED.

# Transmitter Placement

## Determining Transmitter Location

- Choose a location for the TRANSMITTER module that is far enough from the driveway edge that vehicles are unlikely to hit it.
- Run the SENSOR cable through the PVC mounting post and plug it into the connector at the bottom of the Transmitter module.
- Leave 2" to 3" of slack in the cable to prevent damage to the connector when the transmitter is removed.
- Test the chosen location before permanently trenching and setting the TRANSMITTER (see **Placing Receiver and Testing System**, page 5).

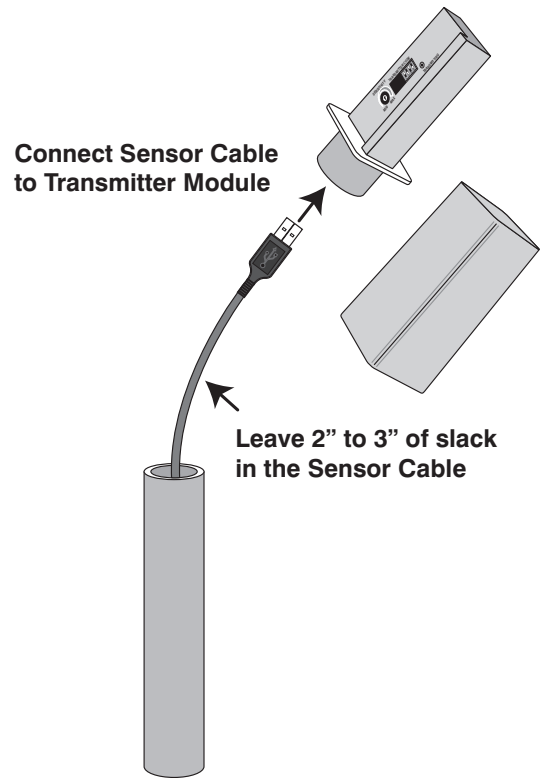

## Installing Transmitter Batteries

**IMPORTANT:** "AA" batteries must be installed at the site where the TRANSMITTER will be located to ensure proper calibration of the transmitter.

- Make sure the SENSOR wire is plugged into the TRANSMITTER.
- Temporarily place TRANSMITTER on the mounting post in ground.
- With TRANSMITTER in desired location install two (2) "AA" batteries.

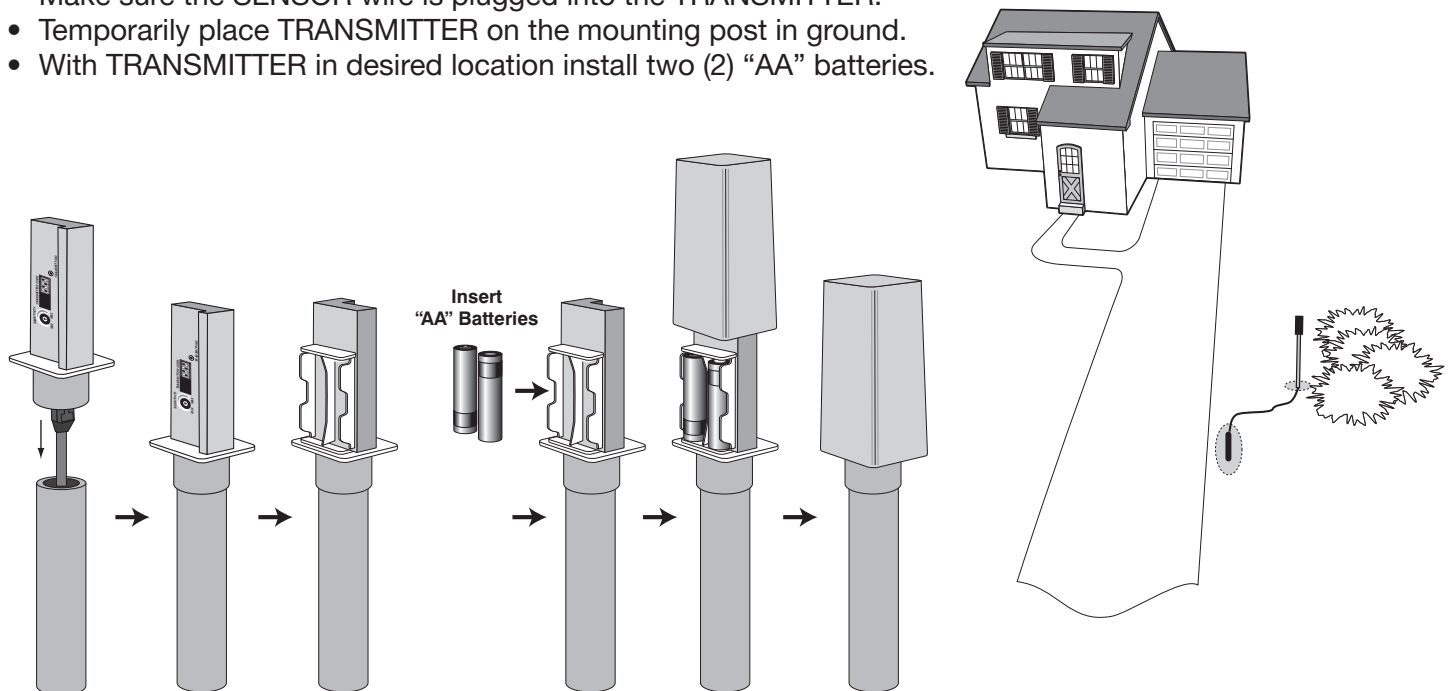



RECEIVER TOP VIEW

## Receiver Description

### RESET

- Press and release the RESET button on the Receiver to clear the VISITOR LED.

### OUTDOOR SENSOR LOW BATTERY

- Yellow LED will blink when the batteries in the Transmitter/Outdoor unit are low.

### VISITOR

- *Green VISITOR LED will blink when a vehicle has been detected. Pressing the RESET button will turn the VISITOR LED off.*

### POWER

- Red LED indicates that power is present and the unit is operational.

### VOLUME

- Turn dial (located on the side of the unit) clockwise to DECREASE the audio volume. Turn dial counter-clockwise to INCREASE audio volume.

# Receiver & Transmitter Setup

## DIP SWITCHES

Match all (4) dip switches on the TRANSMITTER and RECEIVER. The receiver will respond only to transmitter(s) with the same DIP switch setting.

If you change your DIP switch settings make note here for future reference.

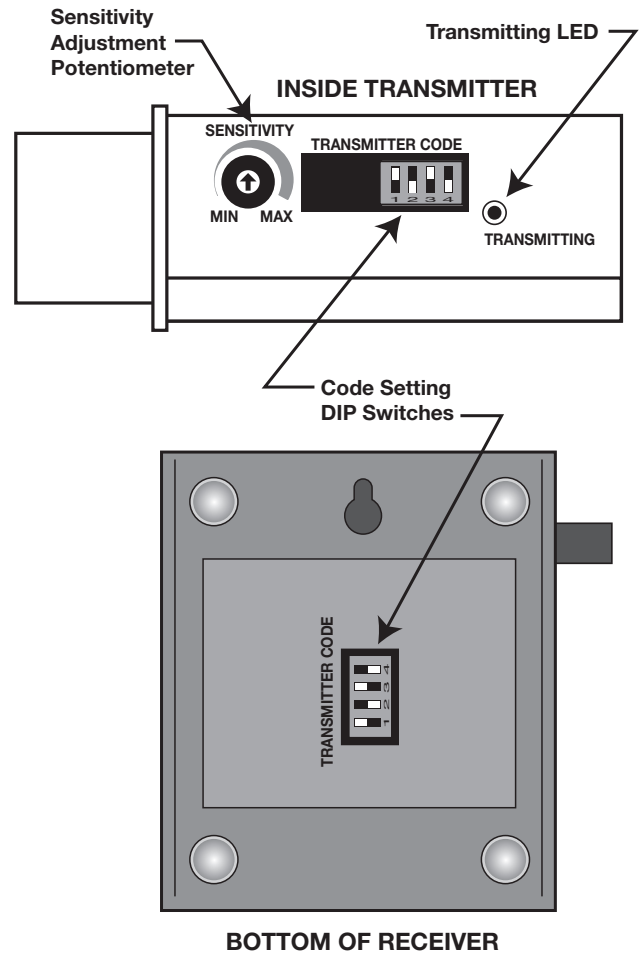
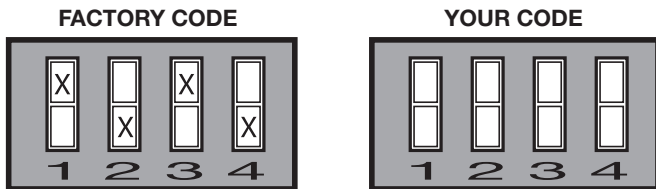

## Placing Receiver and Testing System

### Receiver Placement

- Place the indoor RECEIVER in a convenient location.
- Plug the TRANSFORMER into a 110 VAC outlet and the cable into the receiver's INPUT 9VDC located on the side of the receiver.
- The power LED on the front panel will light up, and there will be a confirmation "beep" tone.
- When a car passes the SENSOR, a signal is transmitted to the RECEIVER from the TRANSMITTER. After the RECEIVER receives the signal, it will chime and the visitor GREEN LED will blink. The VISITOR LED can be reset by pressing the RESET button, but it is not required.
- The OUTDOOR SENSOR LOW BATTERY LED alerts you when the two (2) "AA" batteries in the outdoor TRANSMITTER need to be replaced.

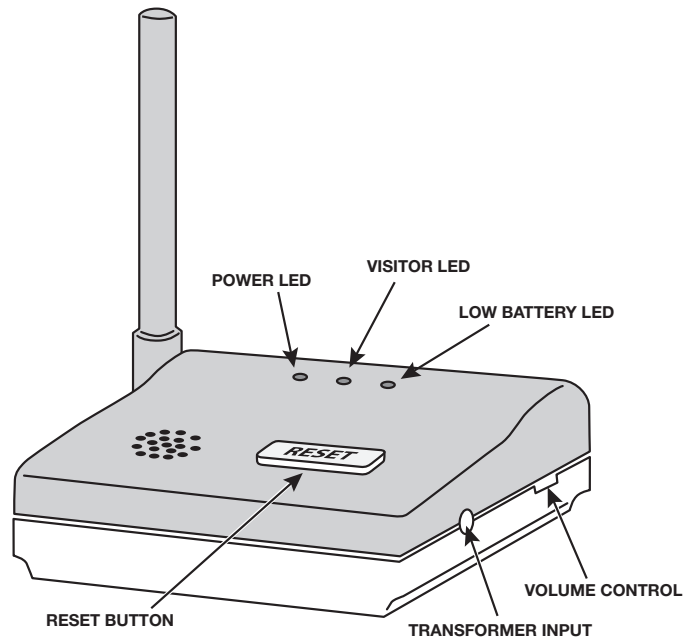

### Testing the System

- Test the range and system by having someone drive an automobile past the SENSOR to be sure the RECEIVER is activated when the vehicle has passed the SENSOR. Kitchen appliances or other electronics may interfere with reception. It may be necessary to adjust the position or relocate the RECEIVER for optimum results. See Troubleshooting Section on page 7.

## Permanently Install Sensor and Transmitter

- Once the system is tested and working, remove the batteries and permanently install the SENSOR, SIGNAL CABLE and TRANSMITTER.
- Bury the SENSOR approximately 1 ft. deep, **flat and parallel**, next to the driveway.
- Dig a narrow trench or slit from the SENSOR to the TRANSMITTER location using a flat spade or other tool. The wire from the SENSOR to the TRANSMITTER should be at least six inches deep to avoid possible damage.
- Secure the TRANSMITTER on the supplied 3 piece PVC pipe by burying the bottom third of the pipe in the soil and tamping the ground around the pipe. DO NOT cover the TRANSMITTER with a metal cover as this will cause signal interference.
- Secure the TRANSMITTER mounting post in the ground so that the TRANSMITTER is upright and approximately 1 ft. above ground.
- Replace the batteries.

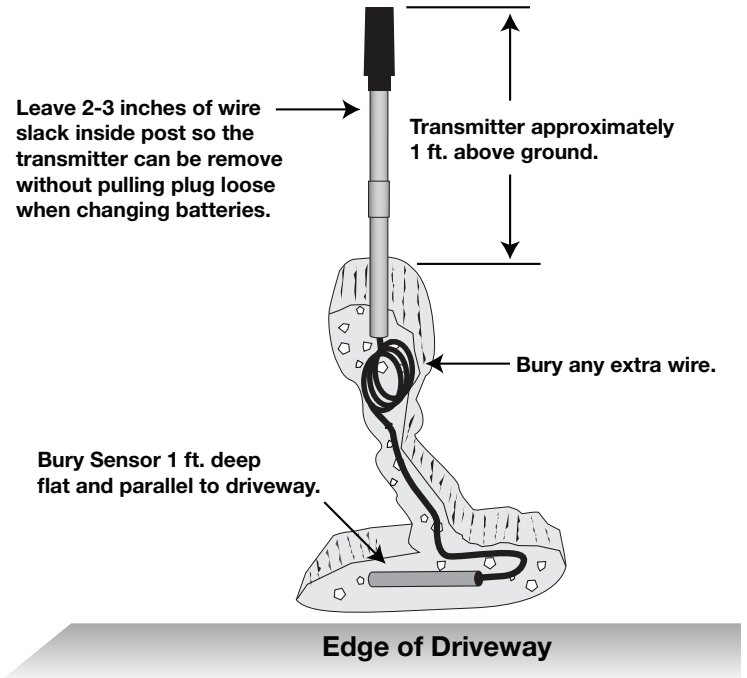

## Sensitivity Adjustment

- The SENSING RANGE can be adjusted from approximately a 3 to 12 foot radius from the SENSOR.
- The potentiometer varies the sensitivity range of the SENSOR to avoid unwanted moving metal objects from activating the alarm (ie: moving gates, metal play equipment, garage doors, other vehicular traffic, etc.)
- With the range adjusted to the maximum of 12 ft., a large metal object moving slowly will be detected up to 12 ft. from the SENSOR, while a small metal object moving slowly might not be detected at the same distance.

### INSIDE TRANSMITTER

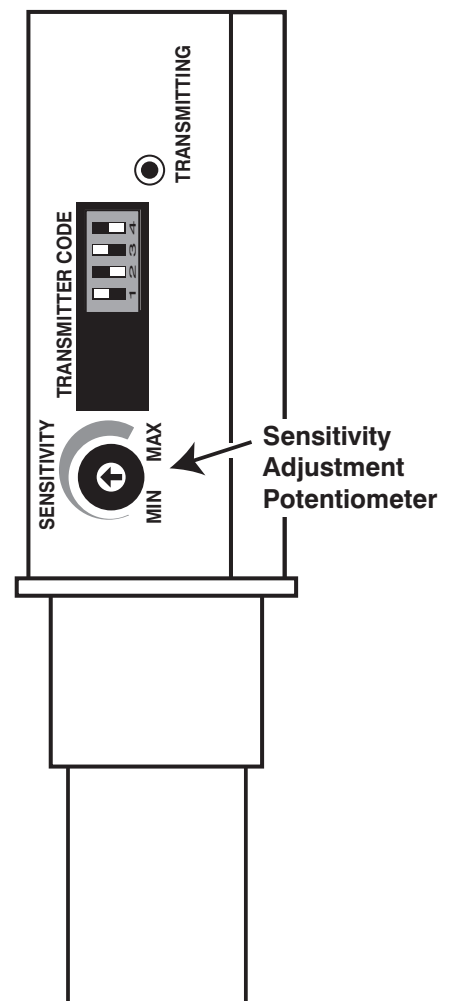

# Troubleshooting

## System not detecting vehicles:

- Remove the outer cover from transmitter and check to see if LED blinks when a vehicle passes the sensor. The LED indicates that a vehicle was detected and it is transmitting.
- Is the distance to the base unit within the max range of 400 ft.? Remember that foliage, trees, and buildings in the line of sight from transmitter to indoor unit will reduce the transmitting range.
- Metal buildings such as mobile homes can block the signal. Try placing the indoor unit close to a window facing the outdoor sensor.
- Kitchen appliances or other electronics may interfere with reception. It may be necessary to adjust the position or relocate the RECEIVER for optimum results.
- Are the DIP switches on the indoor and outdoor units both set the same?
- Make sure receiver volume control is turned up.
- Remove the “AA” batteries - make sure there are no large metal objects or vehicles within 12 feet of the SENSOR - replace the “AA” batteries and allow 60 seconds for it to recalibrate.
  - Replace TRANSMITTER batteries when indoor RECEIVER’s low battery light comes on.
  - In locations where weather varies use Lithium-Alkaline “AA” batteries for best performance.

**NOTE:** When a vehicle passes, the sensor transmits signal to the base station. The unit will beep, and the “Visitor” LED will illuminate. The unit will not beep again until it senses another vehicle/metal object passes the sensor after 15 seconds.

- Is the sensor installed close to driveway as shown?

## Sensor detecting vehicles on the street:

- Is the sensor probe at least 25 feet from the edge of the road? Try moving the sensor farther from the road. Remember to keep it close to the edge of the driveway.
- Adjust the sensitivity adjustment potentiometer to reduce sensitivity. Make small changes until street vehicles are not detected. Counterclockwise adjustments make the sensor less sensitive.

## Indoor base unit detecting a neighbor’s driveway alert:

- Select a different TRANSMITTER/RECEIVER code using the four position dip switches on the transmitter and the indoor unit. All (4) dip switches must be set exactly the same for both the TRANSMITTER and the RECEIVER.

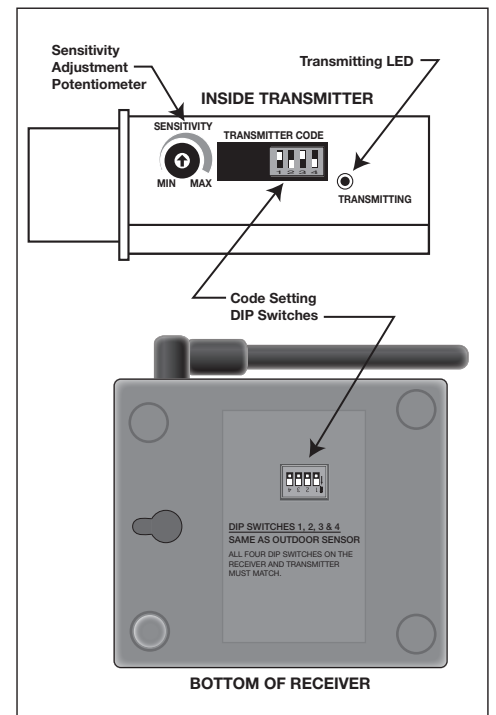
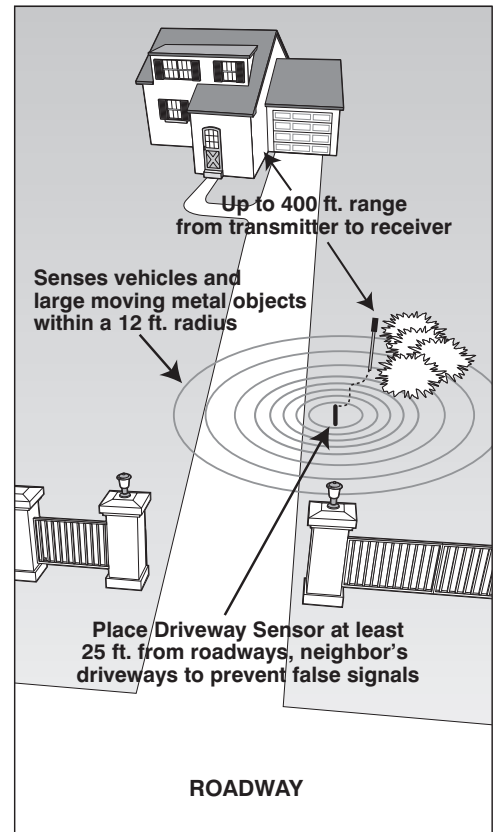

If you change your DIP switch settings make note here for future reference.

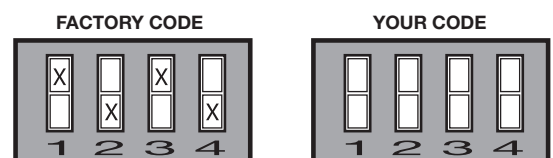

# Limited One Year Warranty

Nice North America LLC gate openers and accessories are covered under warranty by the manufacturer against defects in materials and manufacturer workmanship for a period of one (1) year from date of purchase, *provided the recommended installation procedures have been followed.*

In the case of product failure due to defective material or manufacturer workmanship within the one (1) year warranty period, the product will be repaired or replaced (at the manufacturer's option) at no charge to the customer, if returned freight prepaid to Nice North America, 8740 Crossroads Dr. Suite 100, Olive Branch, MS 38654. **IMPORTANT: Call (800) 421-1587 for a Return Goods Authorization (RGA) number before returning accessory to factory.** Products received at the factory without an RGA number will not be accepted. Replacement or repaired parts are covered by this warranty for the remainder of the one (1) year warranty period or six (6) months, whichever is greater. Nice will pay the shipping charges (equal to United Parcel Service GROUND rate) for return to the owner of items repaired under warranty.

The manufacturer will not be responsible for any charges or damages incurred in the removal of the defective parts for repair, or for the reinstallation of those parts after repair. This warranty shall be considered void if damage to the product(s) was due to improper installation or use, connection to an improper power source, or if damage was caused by electrical power surge, lightning, wind, fire, flood, insects or other natural agent.

This warranty gives you specific legal rights, and you may also have other rights which may vary from state to state. This warranty is in lieu of all other warranties, expressed or implied. **NOTE: Verification of the warranty period requires copies of receipts or other proof of purchase. Please retain these records.**

## FCC Warning

Changes or modifications to this unit not expressly approved by the party responsible for compliance could void the user's authority to operate the equipment. In accordance with FCC Part 15, Section 15.21, the manufacturer is not responsible for any radio or TV interference caused by unauthorized modifications to this equipment. Such modifications could VOID the user authority to operate the equipment.

**NOTE:** This equipment has been tested and found to comply with the limits for a Class B digital device, pursuant to Part 15 of the FCC Rules. These limits are designed to provide reasonable protection against harmful interference in a residential installation. This equipment generates, uses and can radiate radio frequency energy and, if not installed and used in accordance with the instructions, may cause harmful interference to radio communications.

However, there is no guarantee that interference will not occur in particular installations. If this equipment does cause harmful interference to radio or television reception, which can be determined by turning the equipment off and on, the user is encouraged to try to correct the interference by one or more of the following measures:

- Reorient or replace the receiver antenna.
- Increase the separation between the equipment and the receiver.
- Connect the equipment into an outlet on a circuit different from that which the receiver is connected.
- Consult the dealer or an experienced radio/TV technician for help.



**Mighty Mule Customer Service 800-421-1587**

*For more information about the full line of Mighty Mule Automatic Gate Operators, Gate Openers and Access Controls visit*

**[www.mightymule.com](http://www.mightymule.com)**

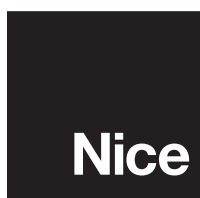

**Niceforyou.com**

©2023 Nice North America LLC.

Mighty Mule is a registered trademark of Nice North America LLC. All rights reserved.

10032594 Rev-C