

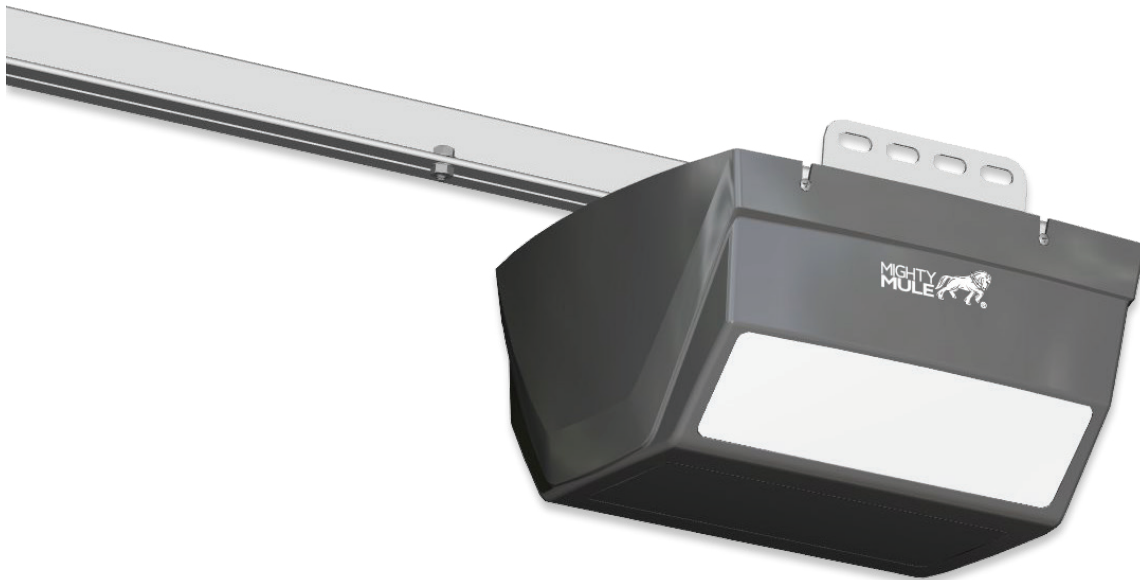

MM9000 Series

MM9545M – MM9434K – MM9333H

Belt Drive Operator Assembly and Installation



- **Please read this manual and enclosed safety materials carefully before installation.**

! WARNING

To reduce the risk of injury to persons – Use this opener only with sectional residential overhead doors. Do not use on one piece or swing doors.



**Need help? DO NOT RETURN to the store. Call: 800-543-1236
or visit www.mightymule.com**

Mighty Mule Sales: 800-543-4283 • Fax 850-575-8912
Mighty Mule Technical Service 800-543-1236

For more information on Mighty Mule's full line of Garage Door Openers, Gate Openers, Accessories and Access Controls, visit www.mightymule.com

Table of Contents:

Important Installation Safety Instructions -----	page i
Please Read Before Beginning Installation -----	page ii
Opener Parts Included -----	page 1
Recommended Tools -----	page 1
Hardware and Parts Included -----	page 2
Planning Overview -----	page 3
Rail Assembly -----	page 4
Installing Belt -----	page 6
Mounting Header Bracket -----	page 8
Attaching Rail Header Bracket -----	page 9
Mounting Opener to Ceiling -----	page 10
Attaching Door Bracket -----	page 12
Attaching Arm to Door Bracket -----	page 13
Installing Photo Beams -----	page 14
Smart Control WiFi Wall Station -----	page 16
Installing Smart Control Wall Station -----	page 17
Installing Backup Battery -----	page 19
Connecting Power -----	page 20
Testing the Wall Station -----	page 20
Aligning the Photo Beams -----	page 21
Programming Opener and Controls -----	page 22
Safety Reversal Test -----	page 23
Programming Remotes -----	page 23
Installing and Programming Keypad -----	page 24
Adjusting the Force Factor -----	page 25
Using the Garage Door Opener -----	page 26
Manual Disconnect -----	page 26
Maintenance and adjustments -----	page 27
Mighty Mule Smart Control APP -----	page 28
Photo Beam Test -----	page 29
Replacing Remote Battery -----	page 30
Installing or Replacing Keypad Batteries -----	page 30
Troubleshooting -----	page 31
FCC Notice and Warranty -----	page 32

IMPORTANT INSTALLATION SAFETY INSTRUCTIONS

Important Safety Information will follow the words CAUTION and WARNING which are used to emphasize potentially hazardous situations.

CAUTION

This type of warning note is used to indicate the possibility of damage to the garage door or garage door opener.

WARNING

This type of warning note is used to indicate possible mechanical hazards that may cause serious injuries or death.

WARNING

IMPORTANT INSTALLATION SAFETY INSTRUCTIONS

Garage doors are large and heavy objects that move with the help of springs under high tension and electric motors. Since moving objects, springs under tension, and electric motors can cause injuries, your safety and the safety of others depends on you reading the information in this installation manual. If you have questions or do not understand the information presented, call Mighty Mule Technical Support at 1-800-543-1236.

TO REDUCE THE RISK OF SEVERE INJURY OR DEATH TO PERSONS, REVIEW THESE INSTALLATION SAFETY STEPS BEFORE PROCEEDING

- 1 READ AND FOLLOW ALL INSTALLATION INSTRUCTIONS.
- 2 Install only on a properly balanced sectional garage door. An improperly balanced door could result in severe injury or death. Repairs to cables, spring assemblies, and other hardware must be made by a qualified service person before installing the opener.
- 3 Disable all locks and remove all ropes connected to the garage door before installing the opener. Ropes connected to a garage door can cause entanglement and death.
- 4 If possible, install door opener 7 feet or more above the floor with the manual release handle mounted 6 feet above the floor.
- 5 Do not connect the opener to the power source until instructed to do so.
- 6 Locate the wall station within sight of the door at a minimum height of 5 feet so that small children cannot reach it. Locate the wall station away from all moving parts of the door.
- 7 Install the User Safety Label on the wall adjacent to the wall station.
- 8 This operator system is equipped with an unattended operation feature. Only use this feature when installed with sectional overhead doors. The door could move unexpectedly. **NO ONE SHOULD CROSS THE PATH OF THE MOVING DOOR.**
- 9 Do not wear watches, rings or loose clothing while installing or servicing an opener. Jewelry or loose clothing can be caught in the mechanism of the garage door or the opener.
- 10 **DISCONNECT THE ELECTRIC POWER FROM THE GARAGE DOOR Opener BEFORE MAKING ANY REPAIRS OR REMOVING THE COVER.**
- 11 Disconnecting the Door from the Opener: With the door in any position (preferably closed), carefully pull the red release handle. **USE CAUTION IF THE DOOR IS OPEN.** An open or partially open door may fall rapidly if disconnected from the opener. Do not allow anyone in the path of the door.

WARNING

Children operating or playing with a garage door opener can injure themselves or others. The garage door could cause serious injury or death. Do not allow children to operate the remote control(s) or the wall station. Install the wall station out of reach of children and away from all moving parts of the door. The door must be clearly visible from the wall station. A moving garage door could injure someone under it. Only activate the door when it is properly adjusted, when it can be seen clearly, and when there are no obstructions to the door travel.

Please Read Before Beginning Installation

This garage door opener kit includes parts and supplies needed for installation in most garages and on most sectional garage doors. A few additional parts and supplies may be needed for installation in your garage and to your garage door. While going over these instructions, please note any additional items you may need.

Measure the height of your door. For doors taller than 7' and up to 8' in height, you will need a rail Extension Kit for the door to fully open.

Does the header above the garage door where torsion springs are used extend far enough above the spring(s) to allow mounting of the header bracket? If not, or if you can't tell you will probably need a piece of 2"x 4" or 2"x 6" lumber to span across wall studs (see page 8).

If you have a finished ceiling, you will need a piece of angle iron which can span across beams or trusses where the opener will be mounted (see page 11).

Remove all ropes and T-handles connected to the garage door. Remove or disable all locks connected to the garage door. It is recommended that closed loop lifting handles with no protruding parts remain.

IMPORTANT: Check condition of your door and all its associated hardware.

Check tracks, springs, hinges, rollers. Is anything loose or appear to be worn? If so, call a qualified professional for an evaluation and repairs. **DO NOT ATTEMPT TO ADJUST SPRINGS OR THEIR ATTACHED PARTS!**

Check the door balance:

1. Slowly open the door all the way, and then close it all the way. Notice if there is any binding, sticking or rubbing. The door should move smoothly in both directions.
2. Raise the garage door about halfway up. Carefully release the door and see if the door balances. It should stay in place. Close the door.

IMPORTANT: If the garage door is unbalanced or the door travel isn't smooth, have a qualified garage door professional adjust or repair the door.

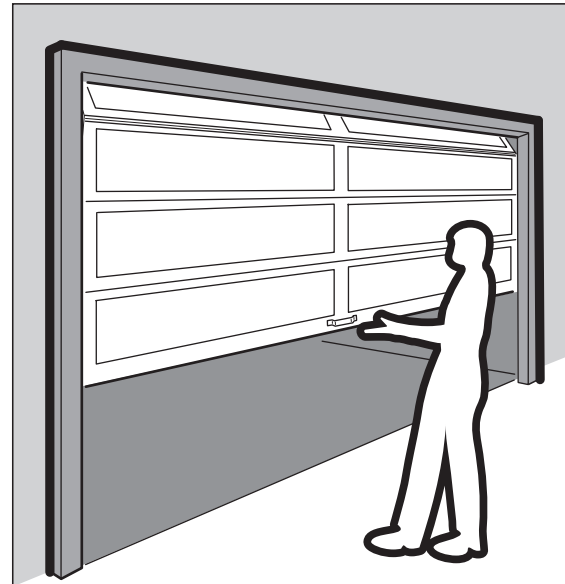

OPENER PARTS INCLUDED

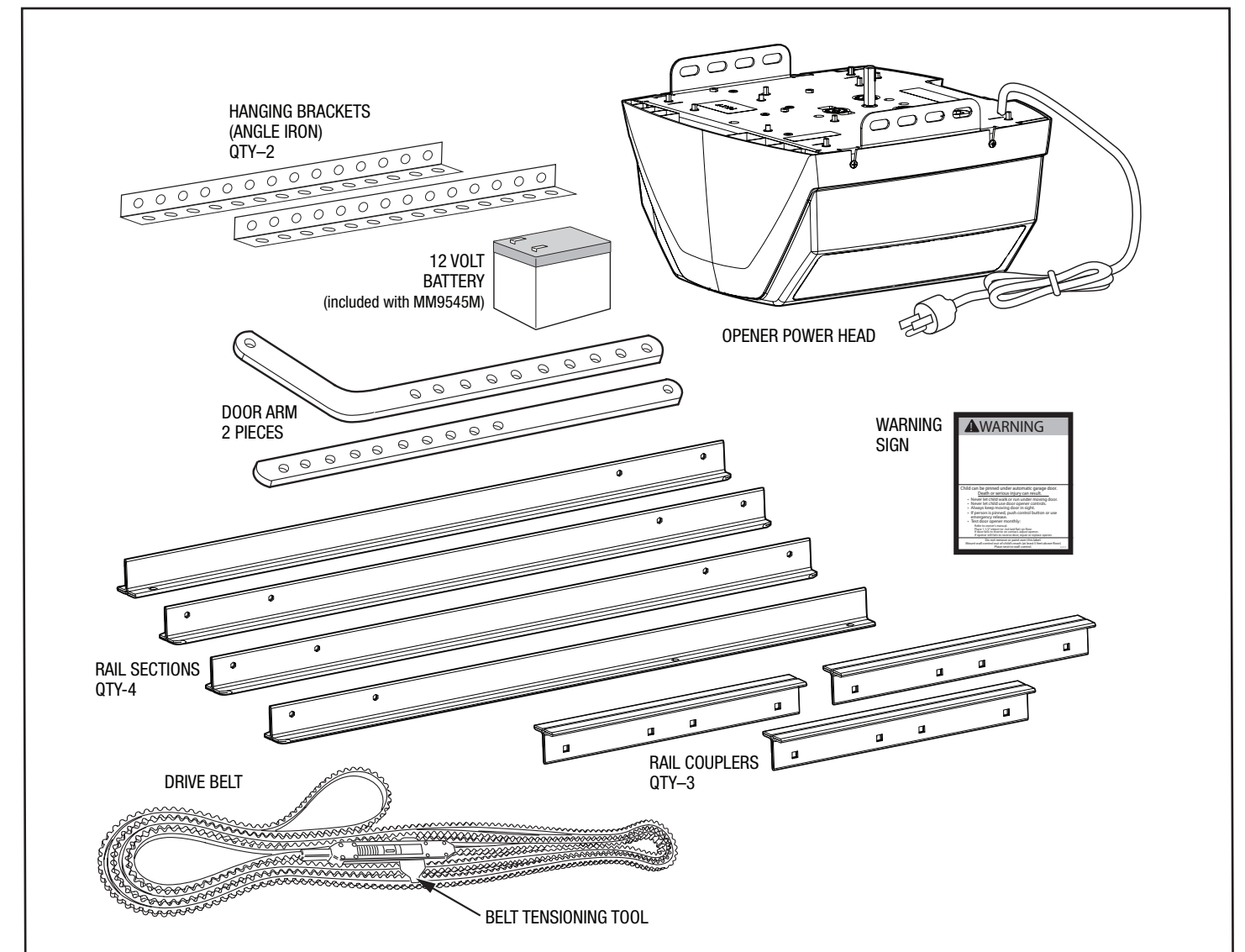

RECOMMENDED TOOLS

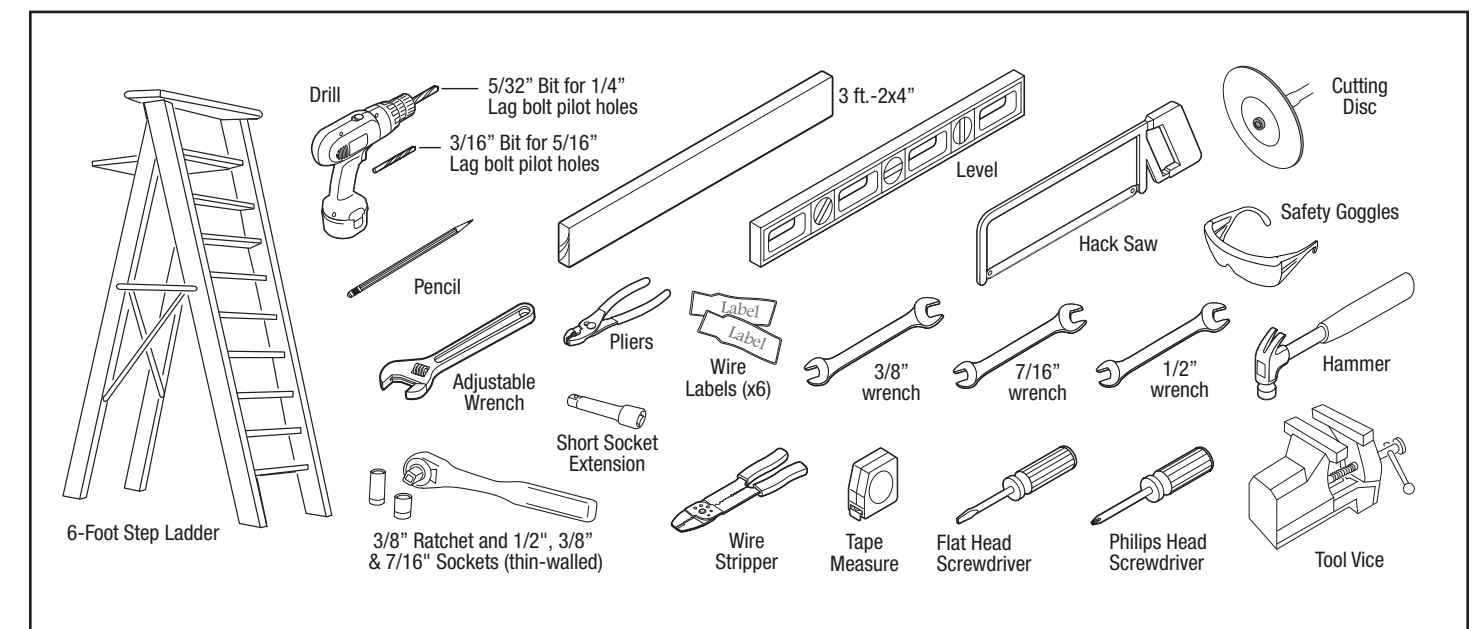

HARDWARE and PARTS INCLUDED

PARTS PACK #1 – RAIL ASSEMBLY PARTS

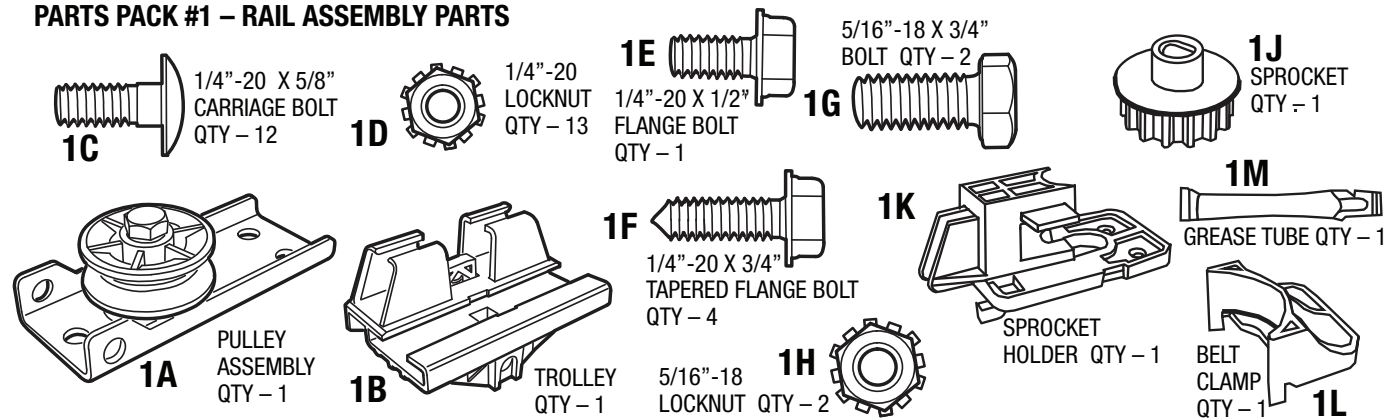

PARTS PACK #2 – OPENER INSTALLATION PARTS

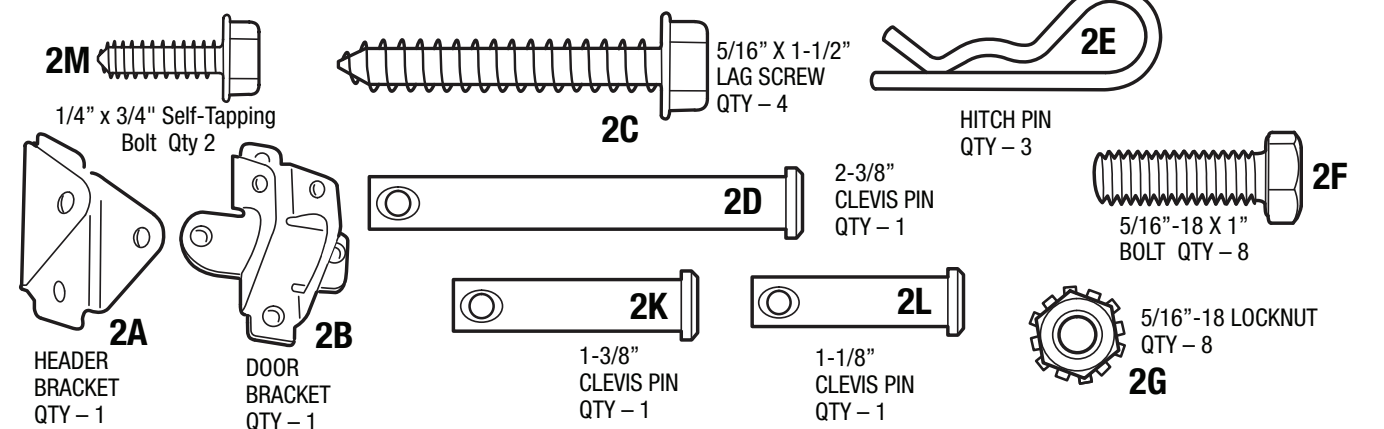

PARTS PACK #3 – PHOTO BEAM PARTS

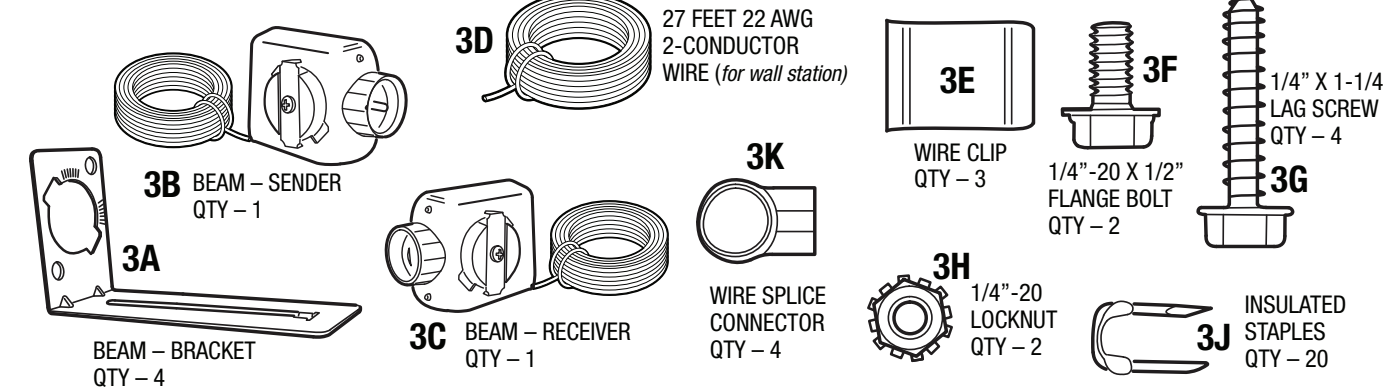

ACCESSORIES

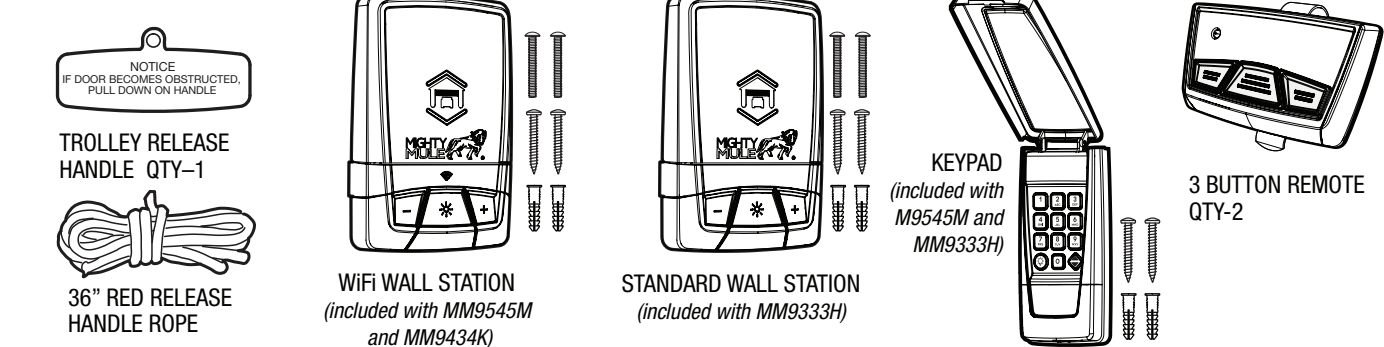

PLANNING OVERVIEW

This is an example of a single 7 foot garage door installation. Depending on your application additional materials may be required.

! WARNING

To reduce the risk of injury to persons – Use this opener only with sectional residential overhead doors. Do not use on one piece or swing doors.

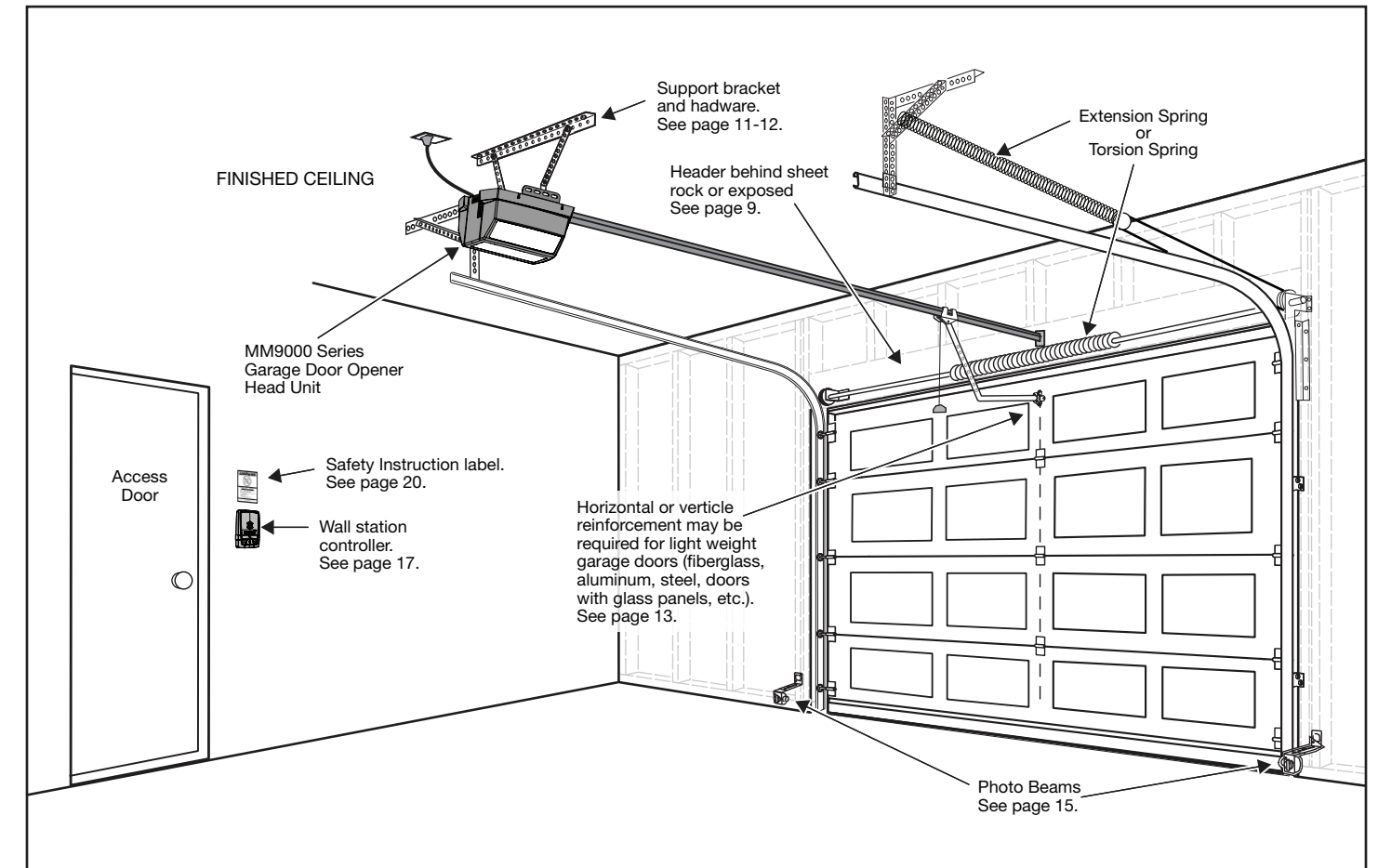

Additional Items You May Need

- Some 2"x4" lumber – use for header bracket support, installation spacer and force testing. See pages 8,10, and 23.
- Door reinforcement for door bracket attachment – required if you have a lightweight steel, aluminum, fiberglass or glass panel door that does not have a mounting plate included.
- Additional angle iron or other materials for hanging the garage door opener head unit. See page 11.
- Belt rail extension kit (Model MMEXT8) is required if your garage door is 8 feet tall.

RAIL ASSEMBLY

Assembly Overview

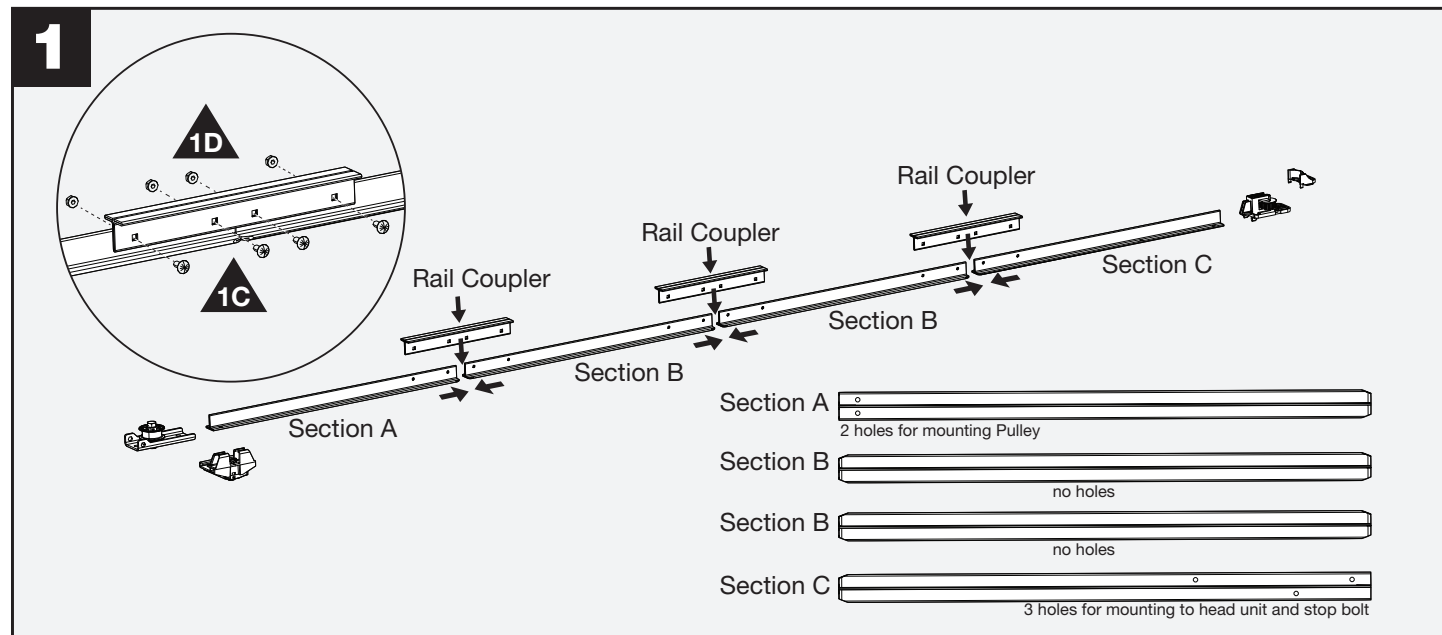
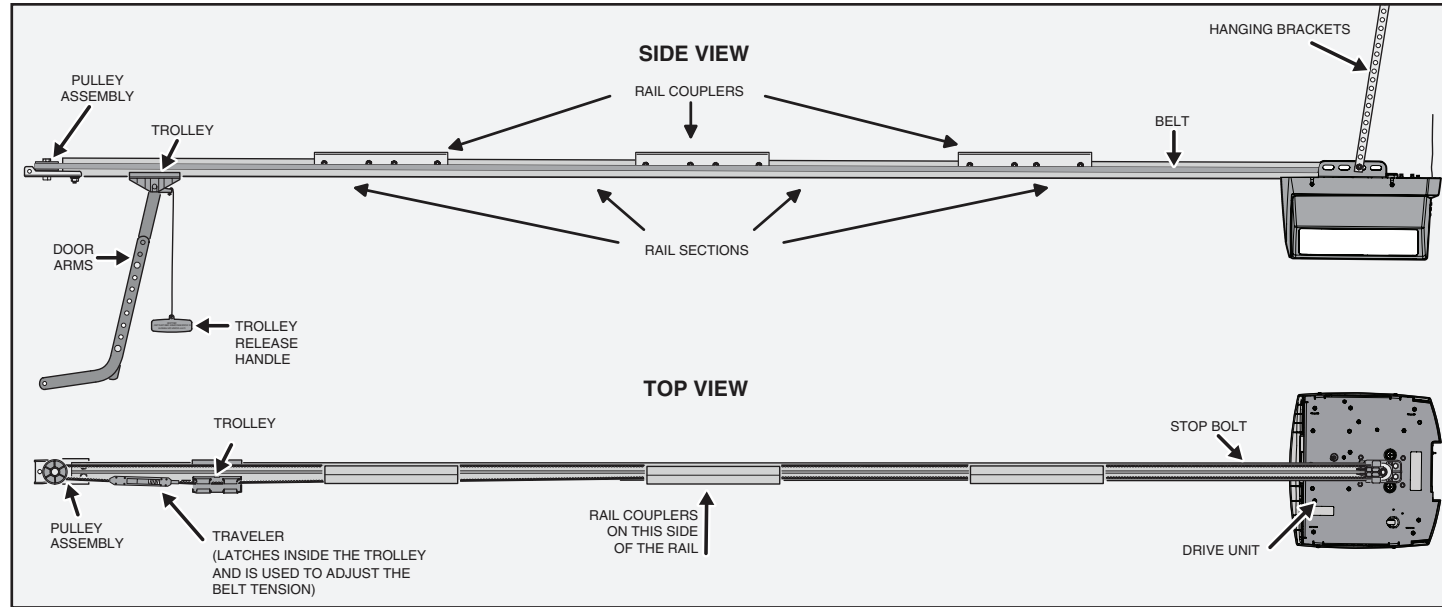

Layout Rail Sections as show and connect using Rail Couplers and 1/4"-20 x 5/8" Carriage Bolts and 1/4"-20 Keps Nuts (supplied).

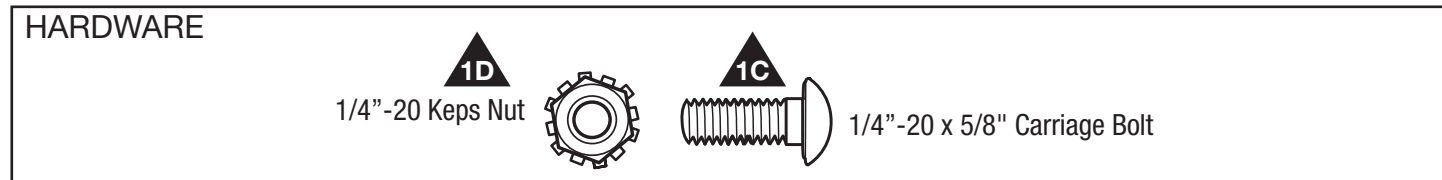

RAIL ASSEMBLY - continued

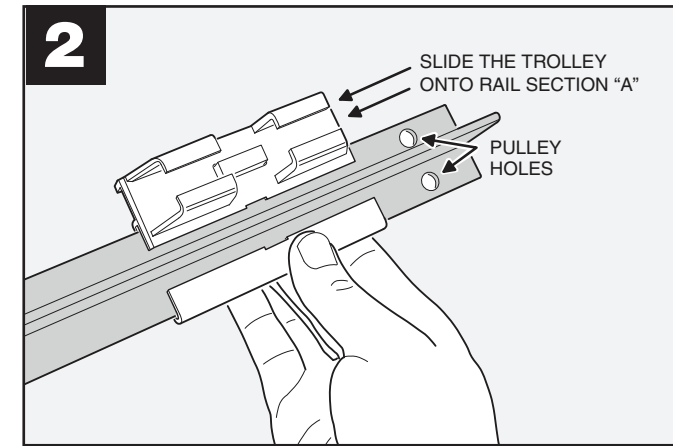

Slide the Trolley onto the rail Sections "A". Be sure of proper trolley orientation.

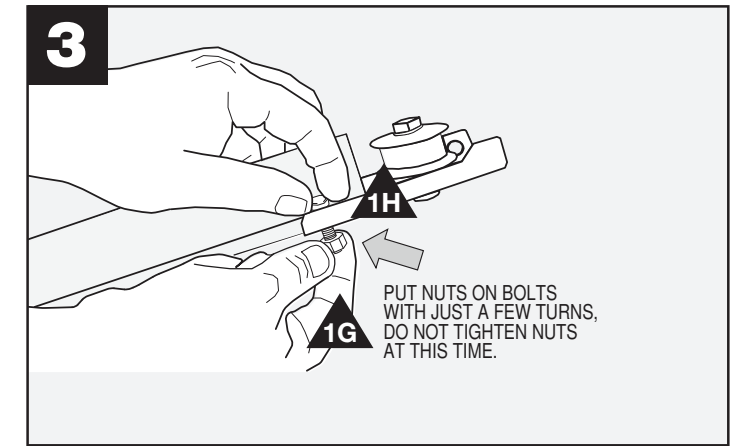

Attach the Pulley Assembly to rail Section "A" with (2) 5/16"-18 x 3/4" bolts and (2) 5/16"-18 Keps nuts (supplied). DO NOT FULLY TIGHTEN AT THIS TIME.

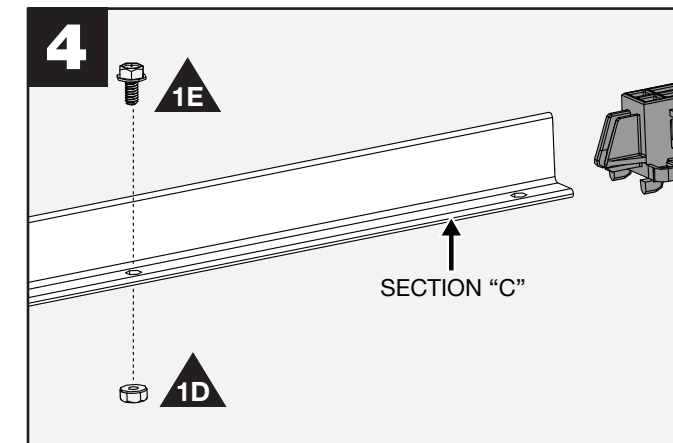

Install trolley stop using 1/4"-20 x 1/2" Flange bolt and 1/4"-20 keps nut (supplied).

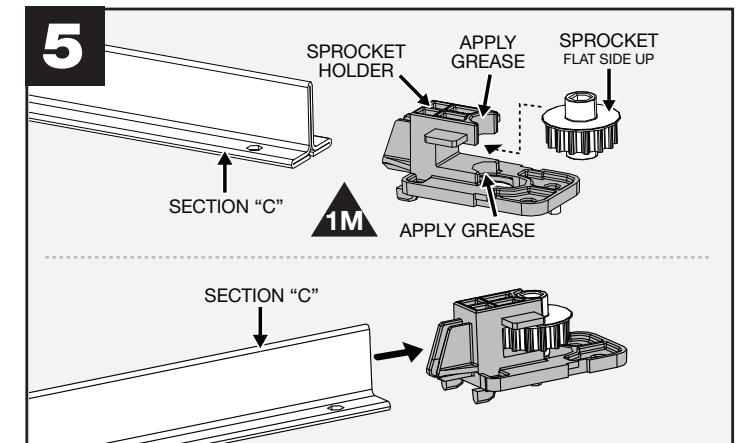

Apply grease to inside surfaces of sprocket holder as shown and place the Sprocket into the sprocket holder with flat side up, then place Sprocket Holder onto rail Section "C", as shown.

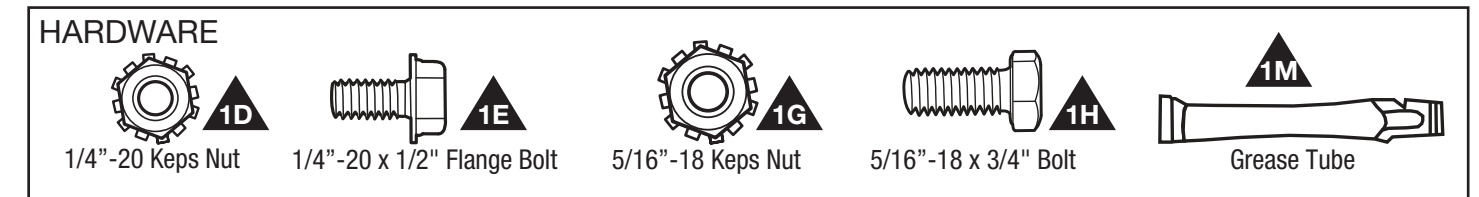
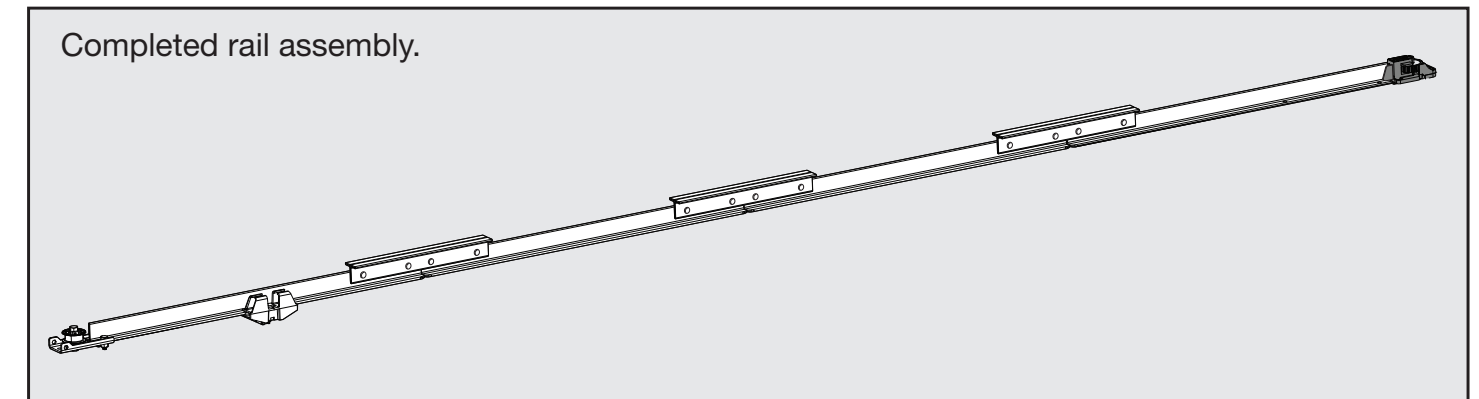

INSTALL THE BELT

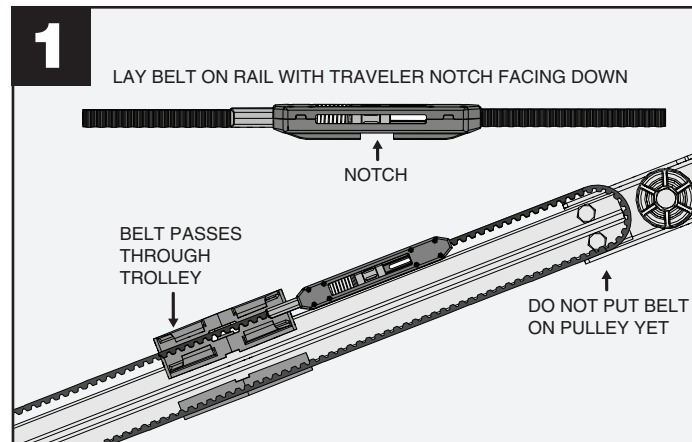

Lay belt on rail assembly with traveler placed through trolley and traveler notch facing downward. Do not place belt on pulley at this time.

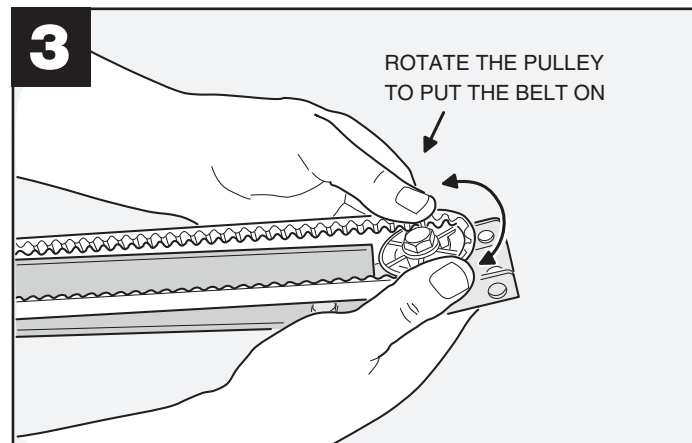

Stretch the belt to the pulley end and rotate the pulley assembly to slide the belt onto it.

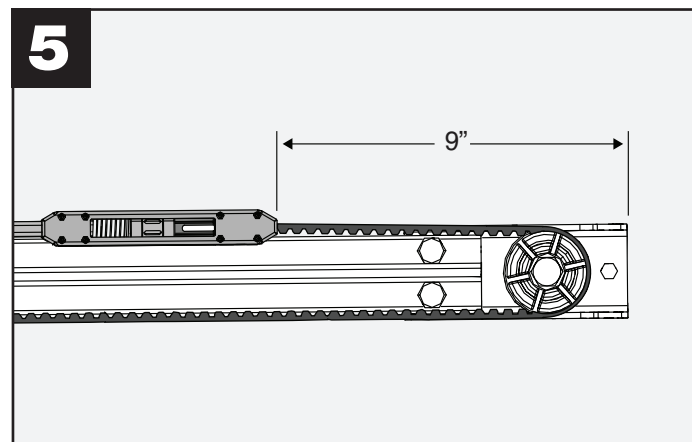

Rotate the belt to bring the end of the traveler to 9" from the end of the rail assembly.

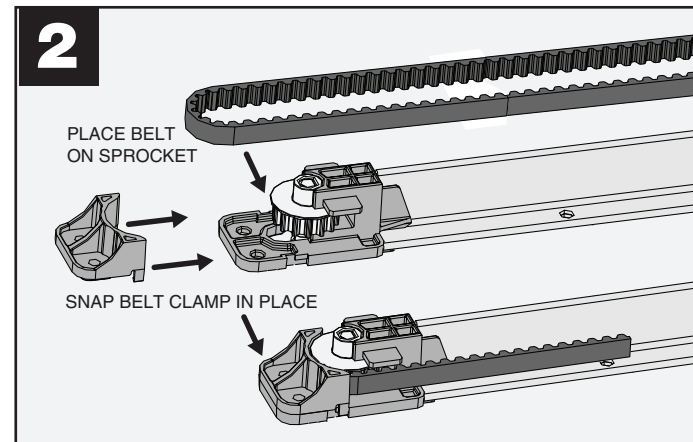

Place belt on sprocket then snap belt clamp in place.

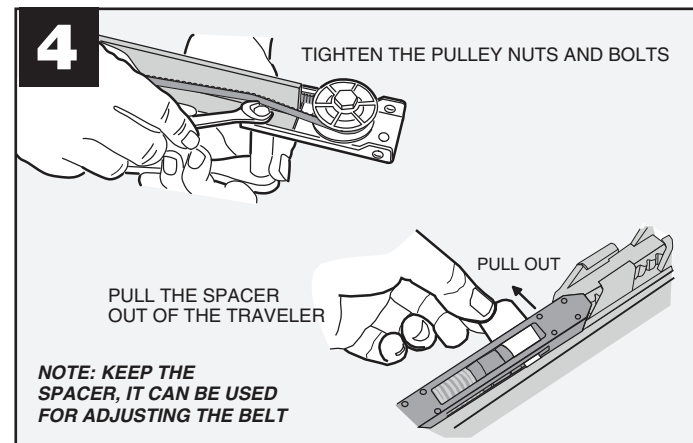

Tighten the (2) 5/16"-18 x 3/4" bolts and (2) 5/16"-18 Keps nuts to secure the pulley assembly to the rail.

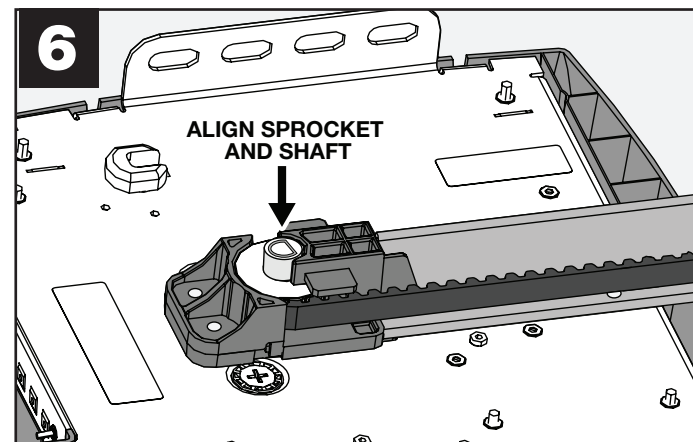

Rotate the sprocket (no more than a full turn in either direction) until the flat side of the sprocket aligns with the flat on the opener drive shaft.

INSTALLING THE BELT - continued

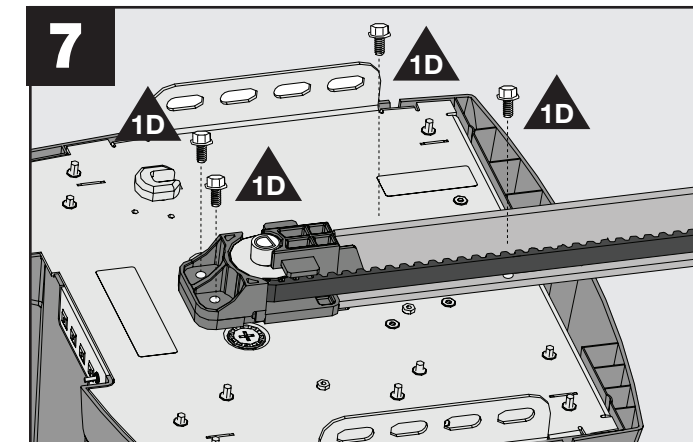

Attach rail assembly to operator head using the four 1/4"-20 x 3/4" tapered flange bolts (supplied).

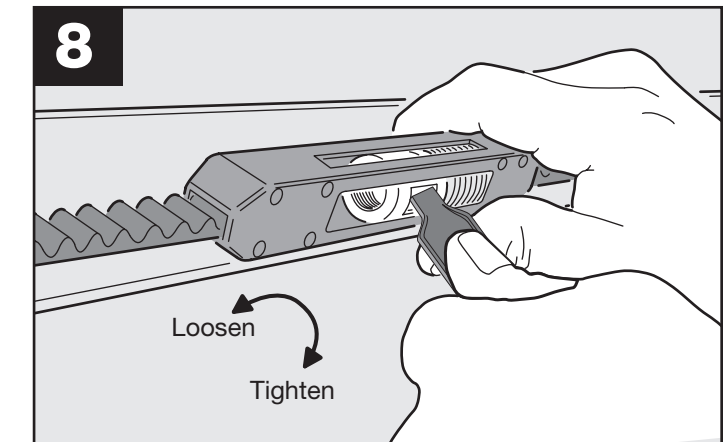

Check that the tensioning spring in the traveler is approximately 1" long. If it is not, hold the traveler so the adjustment wheel is visible through the large slot.

Use the belt tensioning tool, supplied with the drive belt assembly, or a flat blade screwdriver to tighten or loosen the tensioning nut until the spring is approximately 1" long - the width of the tensioning tool.

KEEP THE BELT TENSIONING TOOL FOR FUTURE USE.

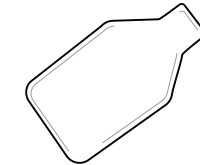

HARDWARE

1/4"-20 X 3/4"
TAPERED FLANGE BOLT

MOUNTING HEADER BRACKET

⚠ WARNING

To prevent **SERIOUS INJURY** or **DEATH**:

- Header bracket **MUST** be **SECURELY** fastened to a structural support on header wall or ceiling. **DO NOT** install header bracket over sheet rock.
- Concrete anchors **MUST** be used if mounting header bracket or 2"x4" lumber into masonry.
- **NEVER** try to loosen, move or adjust garage door, springs, cables, pulleys, brackets or their hardware, **ALL** of which are under **EXTREME** tension.
- **CALL** a qualified door systems technician if garage door binds, sticks, or is out of balance. A door that is not properly working may not reverse when required causing injury or death.

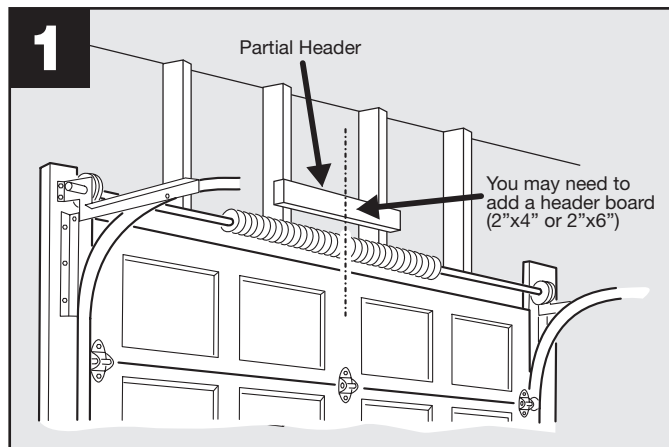

In some installations, the header bracket location may be higher than the door header or no door header exist. This will require adding a 2"x4" (or larger) cross piece to the wall studs for mounting the header bracket. Use lag screws (not supplied) to attach the 2"x4" board to the studs.

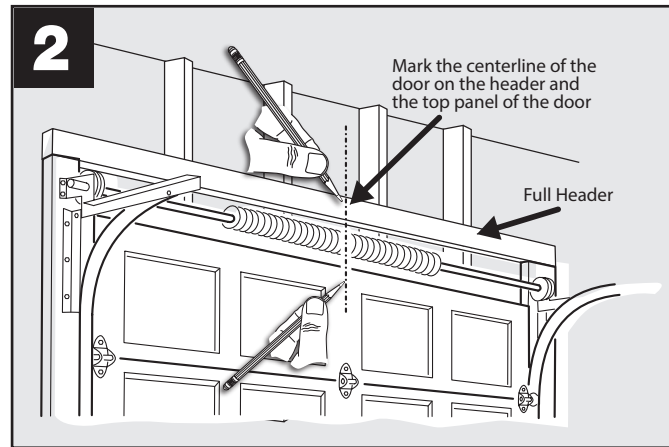

Close the door and from inside the garage, mark the vertical centerline of the door on the header wall and on the top panel of the door.

IMPORTANT: On sheet rock walls you must secure the header bracket to a solid wood header behind the sheet rock.

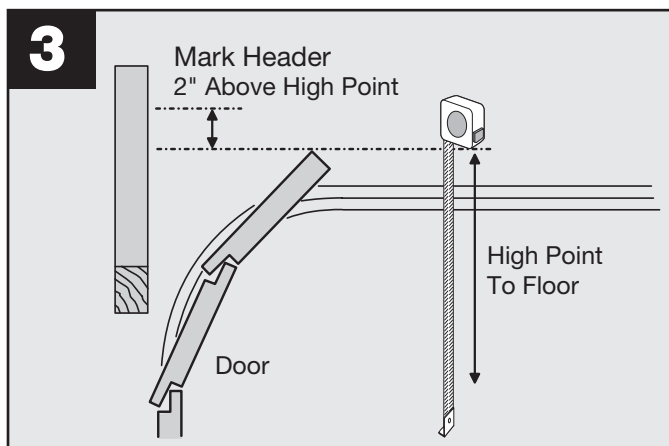

Open the door to the high-rise point (the point where the top edge of the door is highest above the floor) and measure the distance to the floor. Close the door and mark the header 2" above the measured high-rise point.

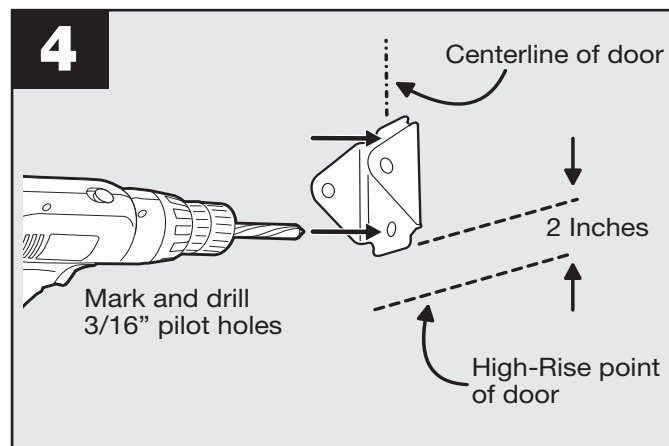

Mount the header bracket on the center line drawn above the door with the bottom edge of the bracket on the line marked 2" above the high-rise point. Mark and drill 3/16" pilot holes.

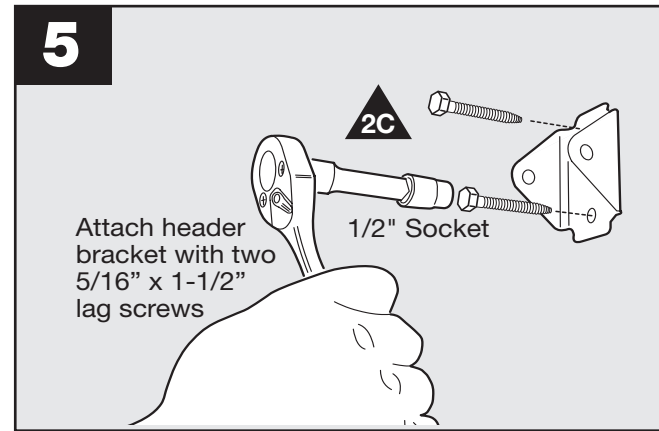

Secure the bracket to header board with two 5/16" x 1-1/2" lag screws (supplied).

ATTACH RAIL TO HEADER BRACKET

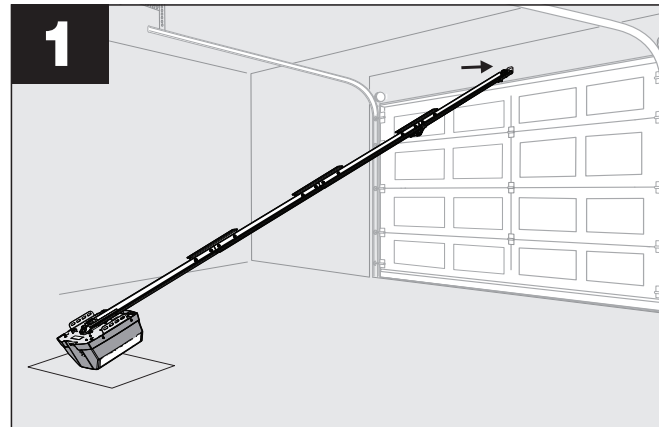

With door in the closed position, place assembled opener on the carton packaging (to protect the head from getting scratched) on the floor with rail towards the door.

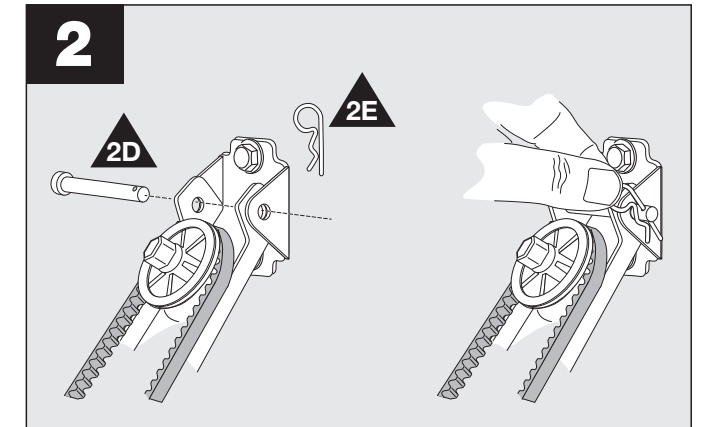

Insert the end of the rail into header bracket. Insert the 5/16" x 2-3/8" clevis pin through header bracket and rail pulley and secure with the hitch pin.

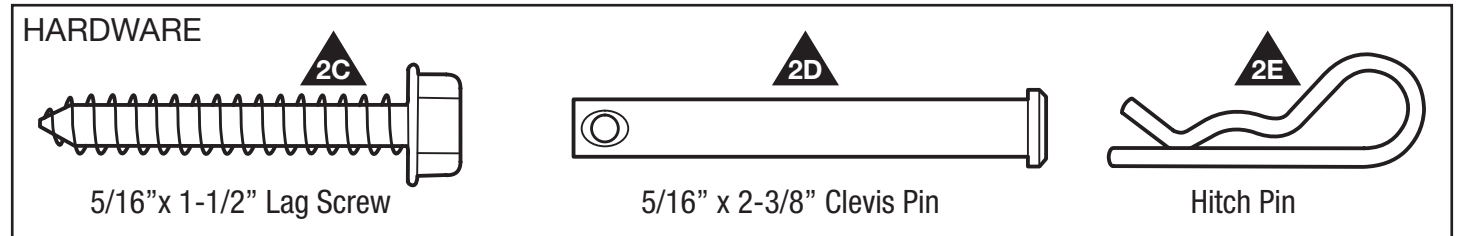

MOUNTING OPENER TO CEILING

! WARNING

To avoid possible serious injury from falling garage door opener, fasten it **SECURELY** to structural ceiling supports. Angle iron and lag screws are recommended. **DO NOT USE NAILS.**

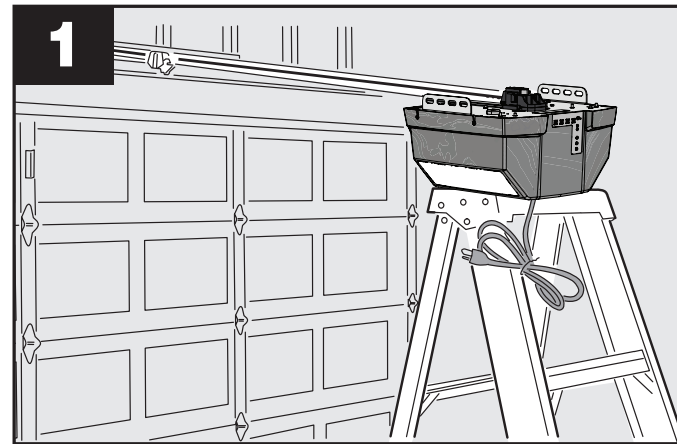

1 Raise the opener head and set it on top of a stepladder. Center the opener head and rail with the centerline mark on the top of the door.

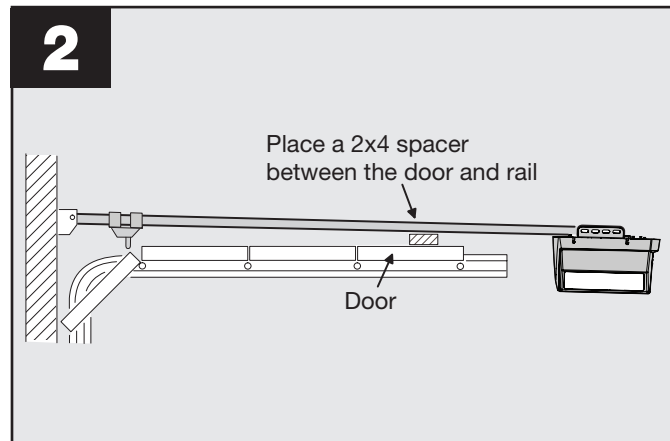

2 Carefully open the door to the full up position. Lay a 2"x4" board flat across the top section of the door as a spacer. Rest the rail on the 2"x4" board.

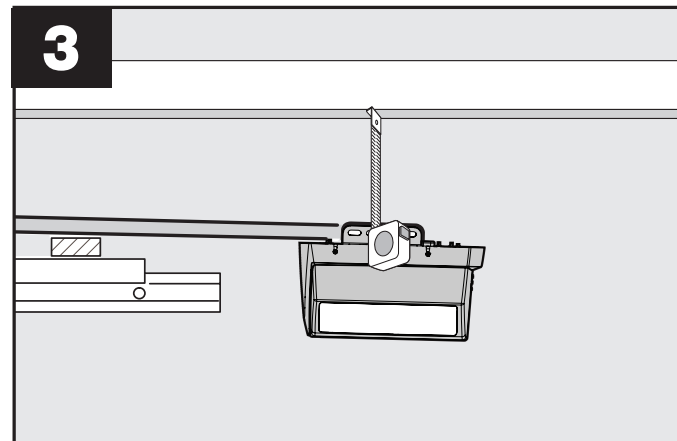

3 Measure the distance from each of the opener's hanging tabs to the ceiling joists or angle iron cross piece and cut angle iron to that length.

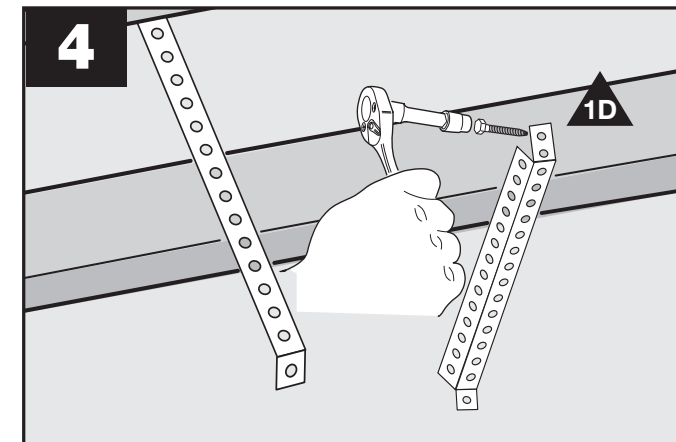

4 For unfinished ceilings: Hold each angle iron in place, mark and drill 3/16" pilot holes, then attach with two 5/16" x 1-1/2" lag screws (supplied).

NOTE: Installation requirements vary with garage construction. Hanging brackets should be angled to provide rigid support. Not all hanging material is provided.

IMPORTANT: On a finished ceiling, be sure there is a joist to fasten to under the sheet rock where the cross piece will be located (use a stud finder). If there is none, install a 2"x4" cross piece of wood between the two closest joists to fasten the head bracket hardware to.

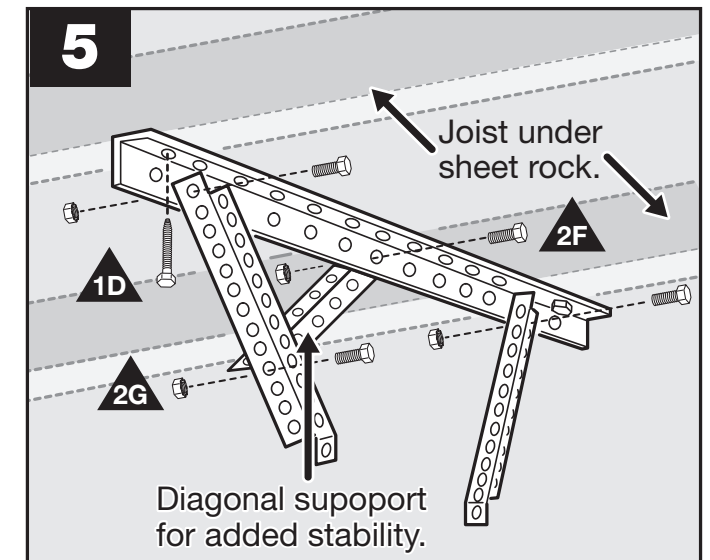

5 For finished ceilings use an angle iron cross piece, secured into ceiling joist with 5/16" x 1-1/2" lag screws. Attach the two hanging brackets to the cross piece with two 5/16"-18x1" hex bolts and 5/16"-18 nuts.

For additional stability add a diagonal support piece of angle iron and secure with 5/16"-18x1" hex bolts and 5/16"-18 nuts.

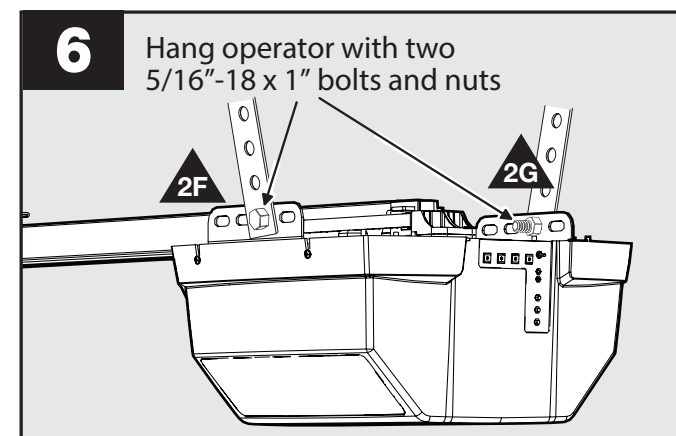

6 Hang operator with two 5/16"-18 x 1" bolts and nuts. Attach opener to hanging brackets using two 5/16"-18 x 1" hex bolts and two 5/16"-18 keps nuts (supplied).

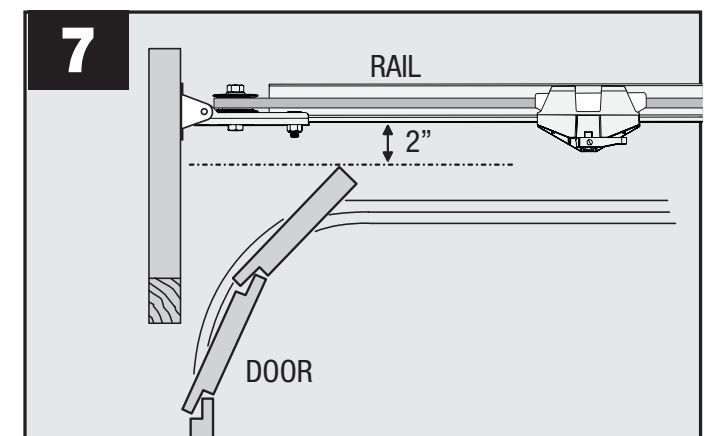

7 Open and close the door manually. The door should clear the rail by at least 2".

HARDWARE SUPPLIED

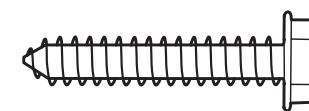

5/16" x 1-1/2" Lag Screw

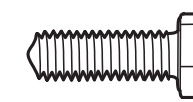

5/16"-18 x 1" Bolt



5/16"-18 Keps Nut

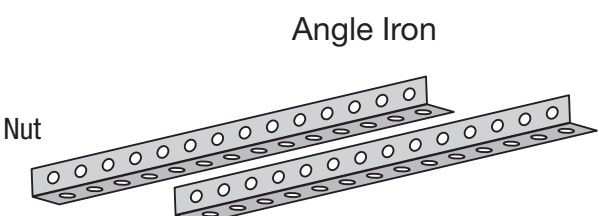

Angle Iron

ATTACHING DOOR BRACKET

CAUTION

Fiberglass, aluminum or lightweight steel doors **WILL REQUIRE** reinforcement before installation of door bracket. If your door doesn't have a reinforced mounting support built in, contact door manufacturer or garage door professional for instructions on reinforcement or reinforcement kits for using automatic door openers.

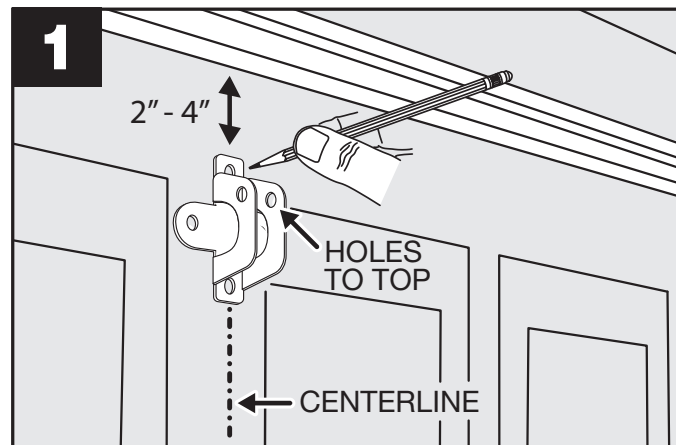
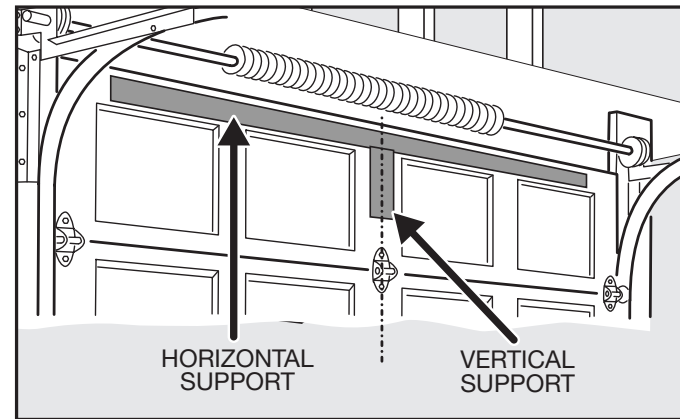

Close the door. Align the top edge of the door bracket 2" to 4" below the top edge of the door. Align the vertical centerline drawn on the door with the center of the bracket and mark holes.

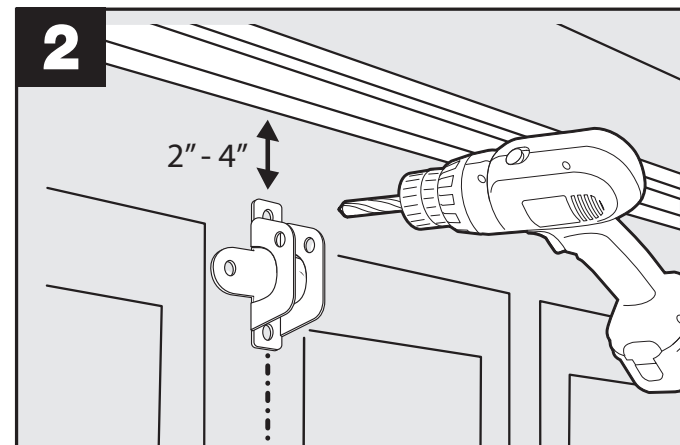

If required, drill 3/16" pilot holes for mounting bracket. Do not drill completely through the door.

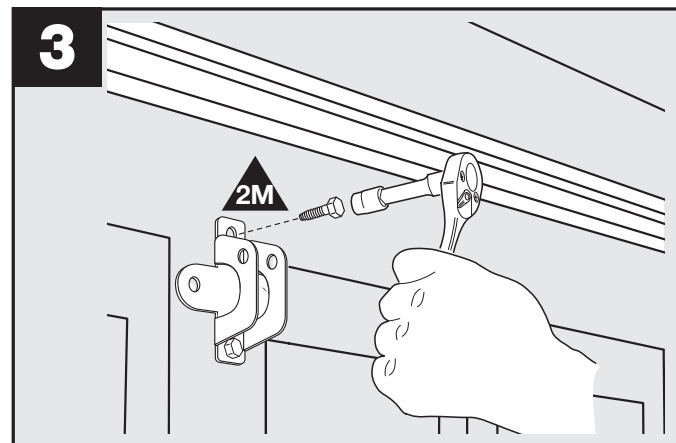

Secure door bracket with two 1/4"x3/4" self-tapping bolts (supplied). The self-tapping bolts are **NOT FOR USE ON WOOD DOORS!**

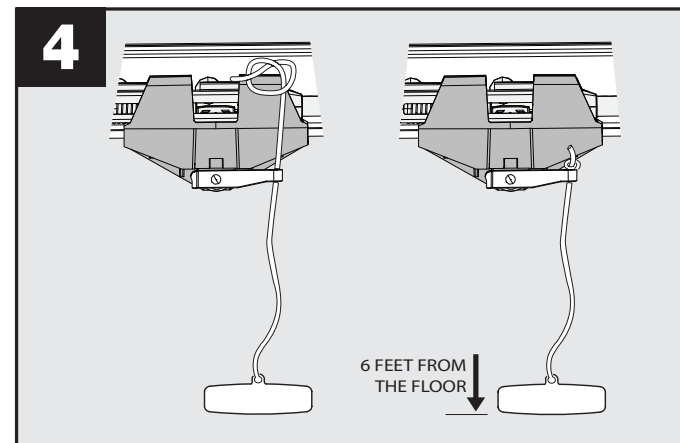
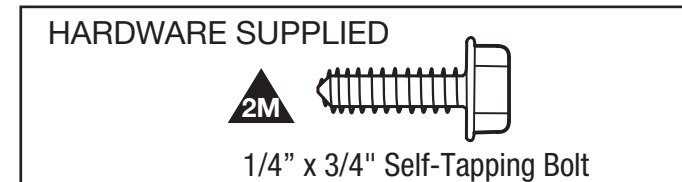

Attach the trolley's release lever to the red release handle with the cord supplied so the handle is 6 feet from the floor. Cut off any excess cord.

ATTACHING ARM TO DOOR BRACKET

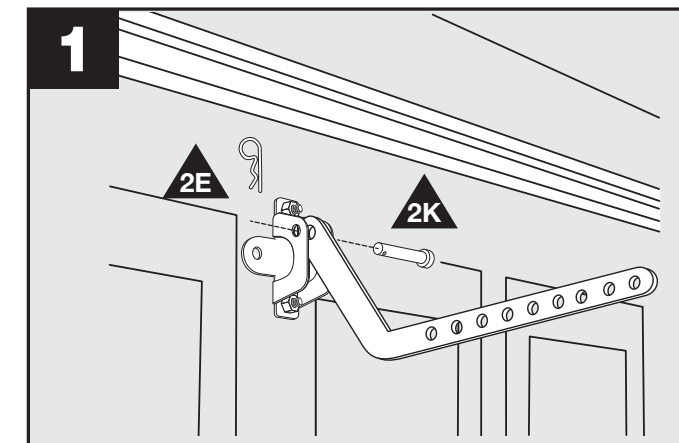

Attach the curved door arm to the door bracket using the 5/16" x 1-3/8" clevis pin and secure with the hitch pin.

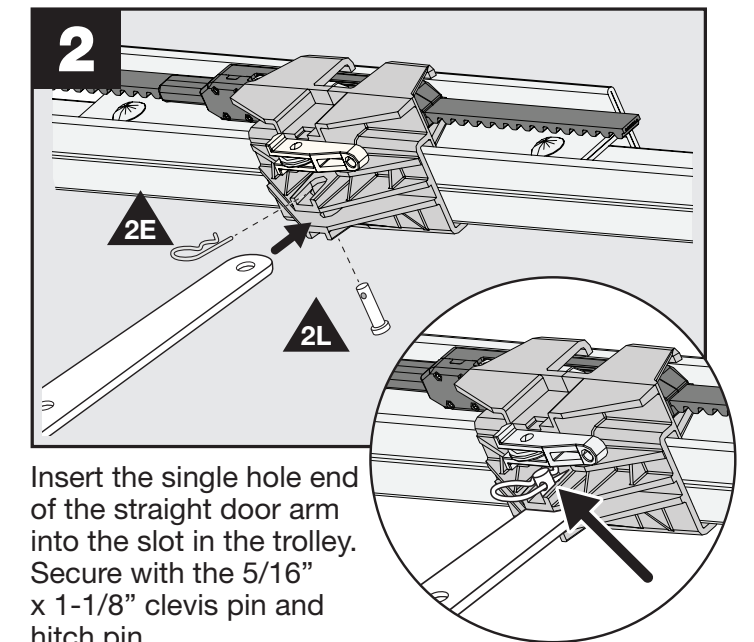

Insert the single hole end of the straight door arm into the slot in the trolley. Secure with the 5/16" x 1-1/8" clevis pin and hitch pin.

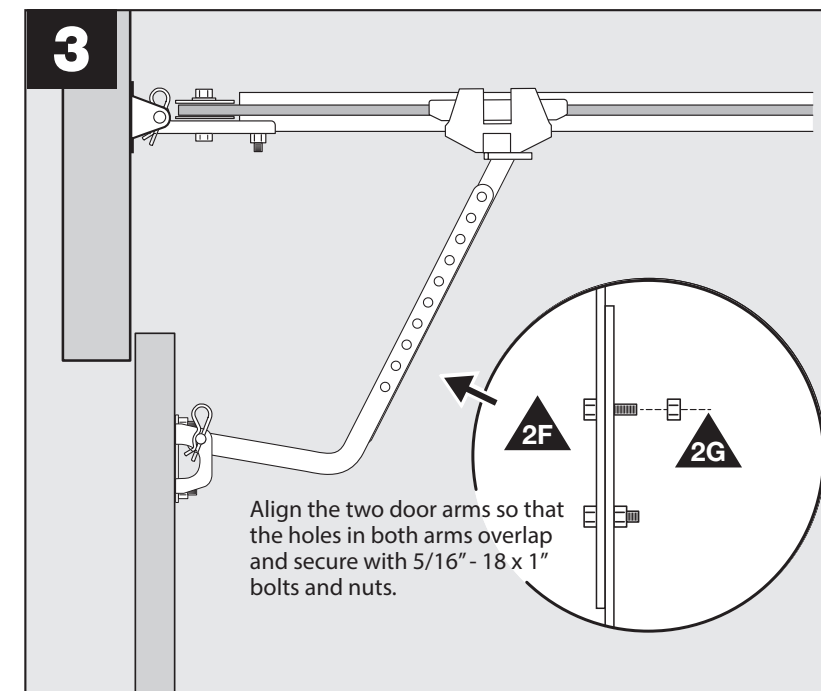

Align the two door arms so that the holes in both arms overlap and secure with 5/16" - 18 x 1" bolts and nuts.

Rotate the curved door arm upward to meet the straight door arm connected to the trolley. Align the two door arms so that the holes in both arms overlap. Secure with 5/16" - 18 x 1" bolts and nuts provided.

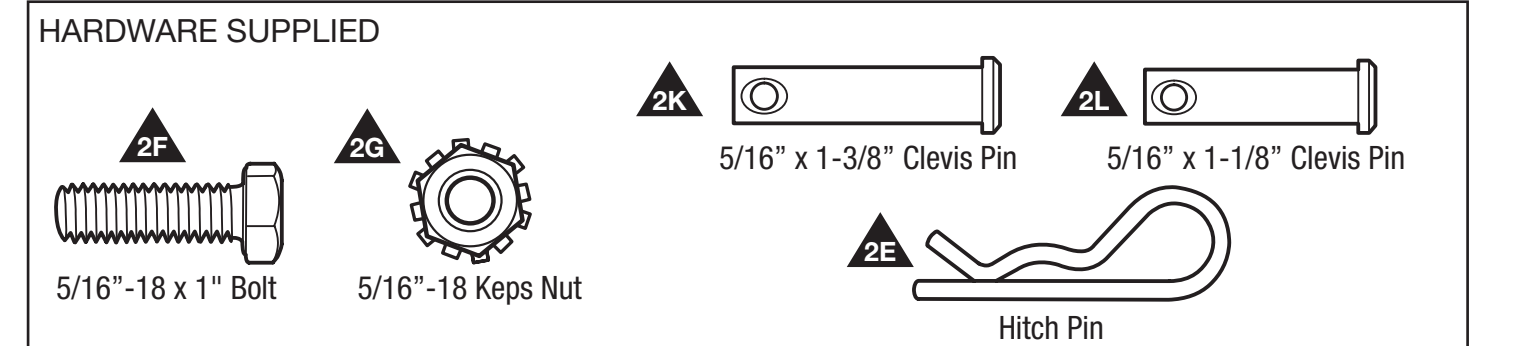

INSTALLING PHOTO BEAMS

⚠ WARNING

- Photo beams **MUST** be installed on the garage door to prevent serious injury or death.
- This required safety reversing sensor **MUST NOT** be disabled at any time.
- Install the photo beams no higher than 6" above the floor.

NOTE: The photo beams infrared light must not be obstructed by the door, or by any part of the door hardware. Use wooden spacers between the beam brackets and wall if necessary to create proper clearance.

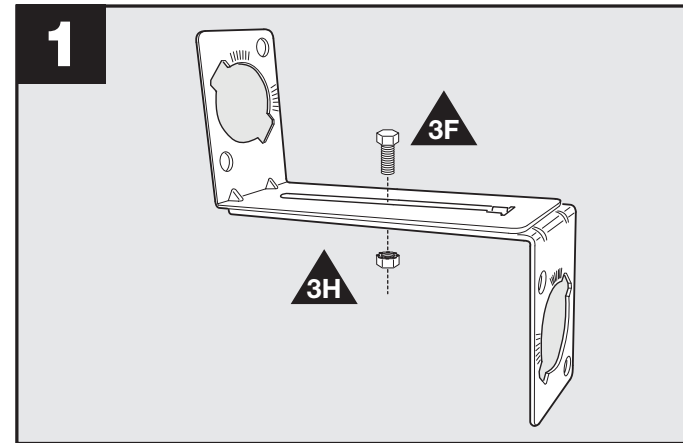

Assemble two photo beam brackets from the four L-shaped brackets using one 1/4"-20 x 1/2" bolt and 1/4"-20 keps nut per bracket (supplied). Use the index marks on the brackets to make the bracket assemblies equal lengths.

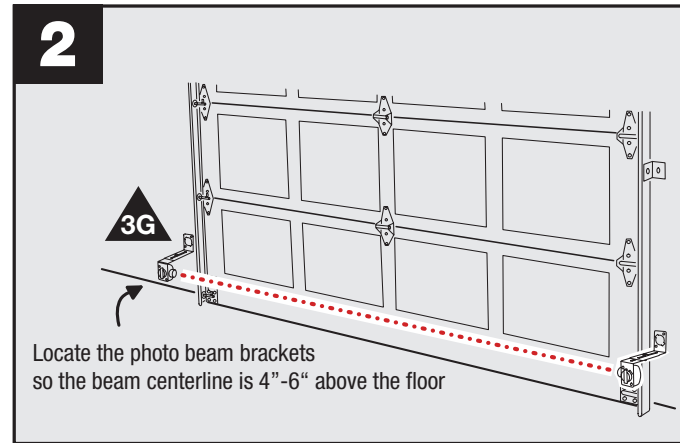

Position the assembled brackets on each side of the door so the center line of the photo beam lenses will be between 4"-6" above the floor. Drill 5/32" pilot holes and mount the brackets with two 1/4" x 1-1/4" lag screws (supplied).

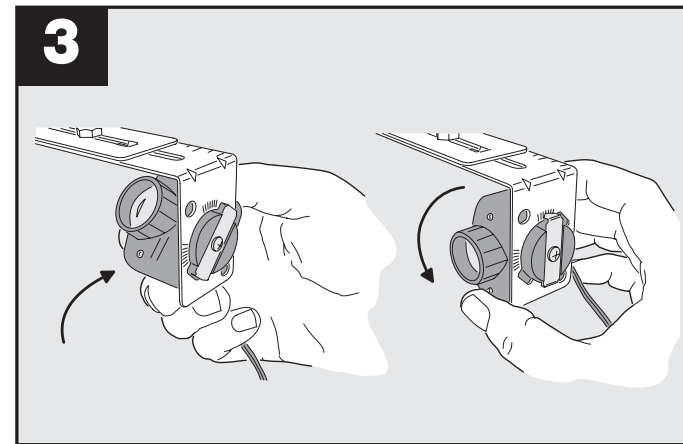

Insert the photo beams into the bracket holes from inside the bracket with the lenses of the units facing each other. Twist the units until the spring clips lock into a detent mark on the brackets.

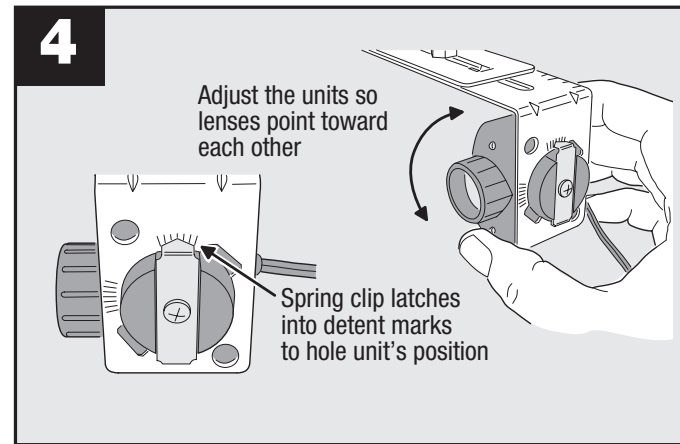

Adjust the photo beams so lenses point toward each other. The spring clip latches into the detent marks to hold unit's position.

HARDWARE SUPPLIED

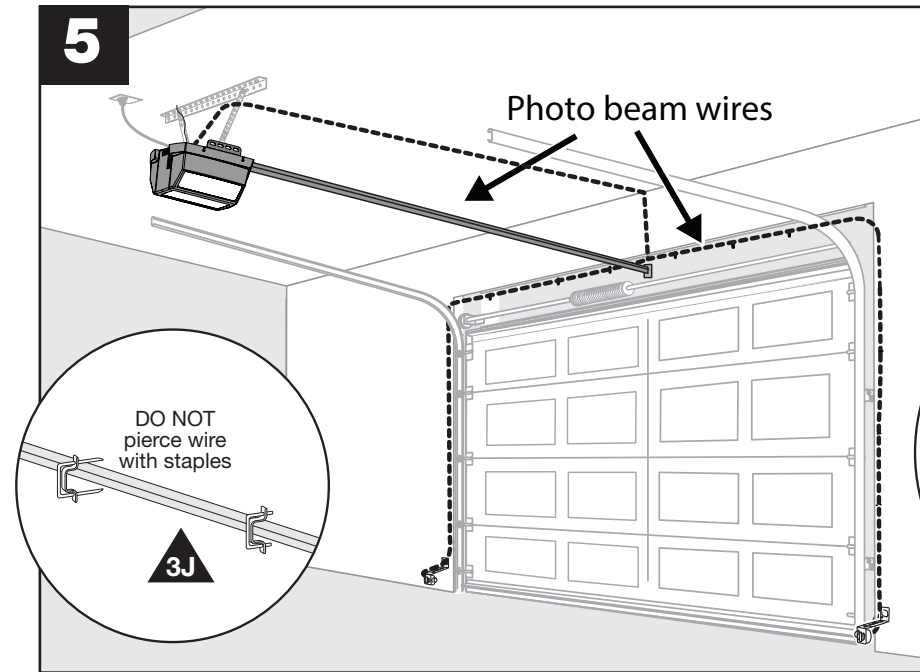
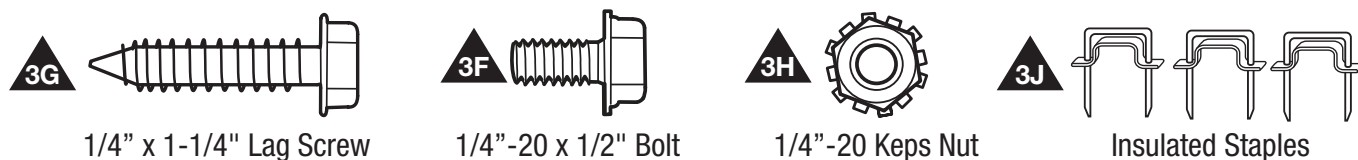

For non-prewired installations, route the wires from the photo beams using insulated staples supplied, up the wall above the door hardware, over to the center of the door, then along the ceiling, and back to the opener head. Cut the wires about 6" longer than needed to reach the opener terminals. Strip back 1/2" of insulation from the ends of the wires.

IMPORTANT: Be careful to route the photo beam wiring away from any moving parts of the door or opener. **DO NOT** route wires along the rail.

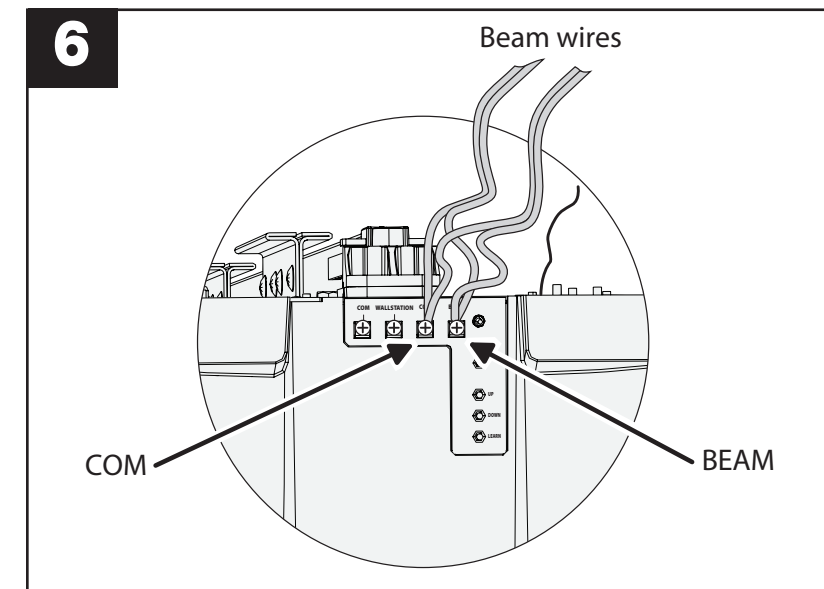

Twist one wire from each pair together, then twist the other wire from each pair together.

Attach either twisted pair to the opener's BEAM terminal. Connect the other twisted pair to the opener's COM terminal.

Note: If an older system is being replaced, use wire labels to mark connection types prior to disconnecting wires.

INSTALLING THE WALL STATION

The Mighty Mule MM9545M and MM9434K come with the MMW200 WiFi wallstation and the MM9333H comes with the MMW100 wallstation without WiFi capability. Installation is the same but functions are different. Illustrations below will highlight the differences.

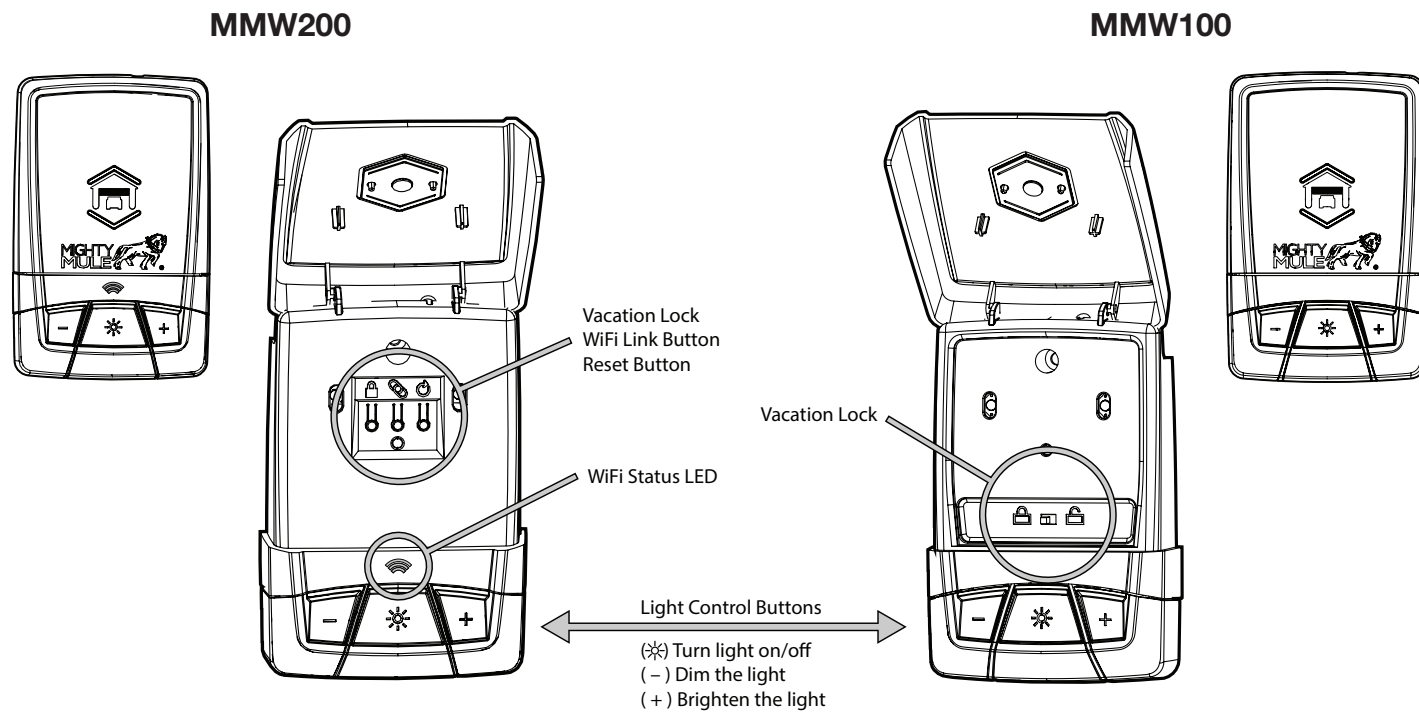

NOTE: 22 AWG 2-conductor wall station and photo beam wire is supplied with the opener, Use this wire or the installation's pre-wiring.

UL NOTE: All low voltage Class 2 cable used with this opener must be UL Listed Type CL2, CL2P, CL2R, or CL2X or other cable with equivalent or better electrical, mechanical, and flammability ratings.

Choose Placement of Wall Station

The Wall Station is typically mounted inside the garage on the wall adjacent to the door into the house. It also can be mounted in any other convenient place meeting the below requirements.

NOTE: For Smart Control Wall Stations the composition of your wall can adversely affect the strength of the Wi-Fi signal. The best spot to mount the Smart Control Wall Station is on a drywall-covered wall framed with wood studs and filled with blown-in or batt insulation.

If possible, avoid affixing the Wall Station:

- to solid brick or concrete walls,
- to metal studs or walls with metal inside and
- on top of or near AC electrical lines.

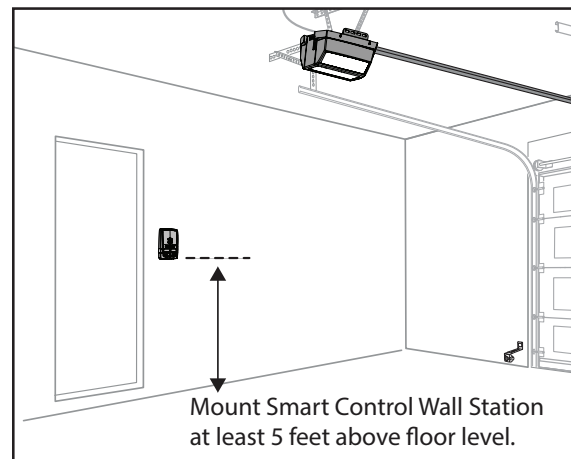

Mount and Wire the Wall Station

Mount the wallstation to the wall or existing electrical gang box using one of the methods shown.

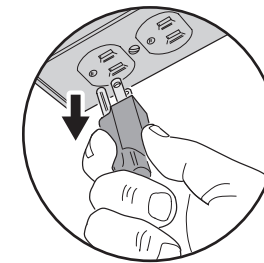

Always make sure the opener head unit's AC power cord is not plugged in before wiring or repositioning the Smart Control Wall Station!

Connect the wall station to the garage door opener head unit using either the supplied or pre-existing wires.

Use the wire that has a mark to connect the COM terminals. Make sure that you connect the COM terminal on the wall station to the COM terminal on the garage door opener head unit.

Next, connect the WALL STATION terminal on the wall station to the WALL STATION terminal on the garage door opener head unit.

IMPORTANT

Wire polarity is critical with the Wi-Fi Smart Control Wall Station.

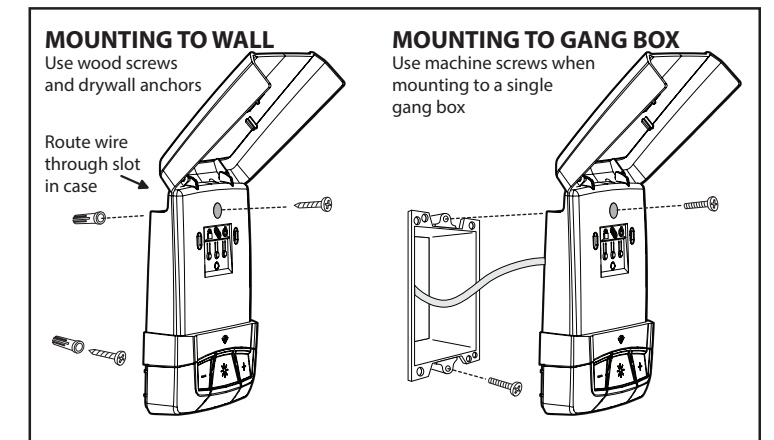

HARDWARE SUPPLIED

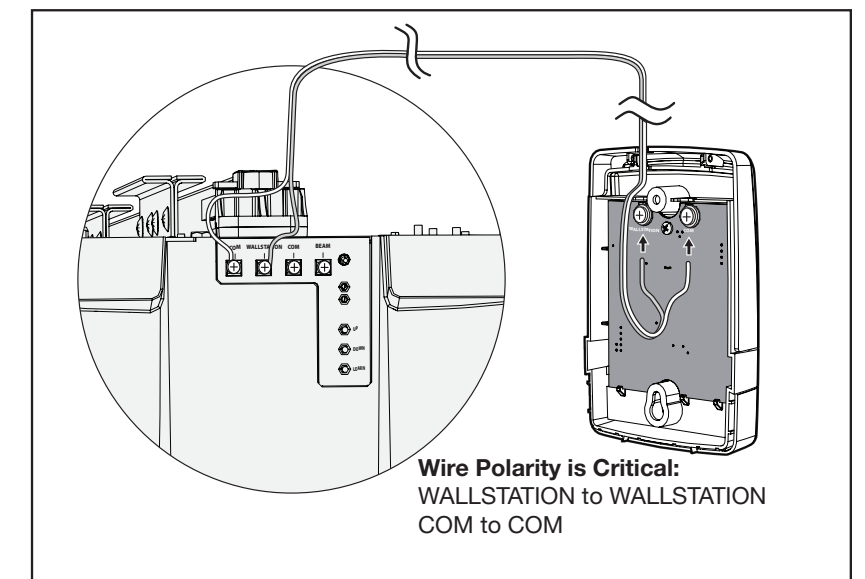
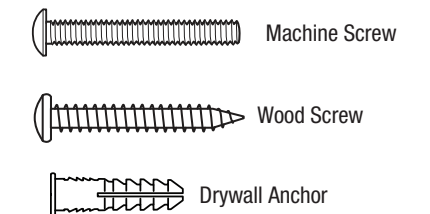

When the garage door operator installation is complete and power has been connected you will find instructions on how to test the wall station on page 20 and how to use the features of the wall station on page 27.

SMART CONTROL Wi-Fi WALL STATION *(if applicable)*

This Smart Control® Wall Station allows operation of the light and door using the buttons, but it does much more when paired with our Android or iOS application. It can operate your garage door, manage your family's access, control lights and inform you of people coming and going, all while you are on the go.

Requirements

To use the Smart Control Wall Station with the app you will need:

- a Wi-Fi network with Internet connectivity,
- a strong Wi-Fi signal in the garage where you are installing the Smart Control Wall Station and
- an Android or iOS phone.

See page 29 for instructions on downloading and installing the Mighty Mule Wi-Fi Smart Control® APP.

Test Wi-Fi Signal Strength

It is paramount that the Smart Control Wall Station receives strong signal from your home's Wi-Fi router.

Check the Wi-Fi signal from your home router. To do this, take your smart phone, connect it to your Wi-Fi network and then place your phone on the wall next to the Wall Station.

If you have 2 or 3 bars on your phone for the Wi-Fi network, the signal is strong and you can proceed. If not, use one of these options to extend your Wi-Fi network's range.

- Move your Wi-Fi router closer to the garage.
- Purchase a Wi-Fi range extender.
- Relocate your wall station to a spot where the signal is stronger.

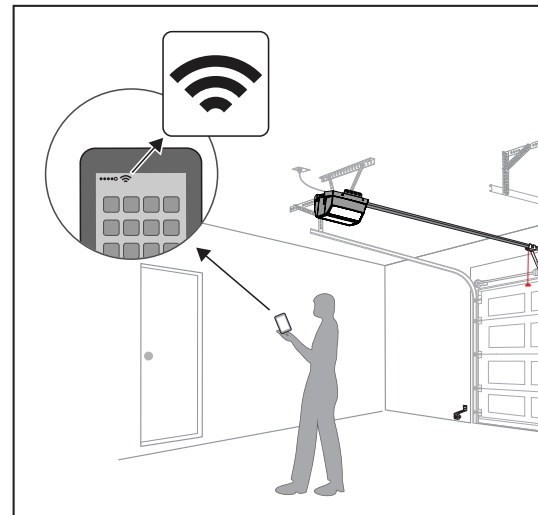

When the garage door operator installation is complete and power has been connected you will find instructions on how to test the wall station on page 20 and how to use the features of the wall station on page 27.

INSTALLING or REPLACING THE BACK-UP BATTERY *(if applicable)*

The 12 Volt, 5.4 Amp hour battery (Model MMB100) provides power to the opener in the event of power outage.

IMPORTANT: Always make sure the opener head unit's AC power cord is not plugged in before installing or changing the battery.

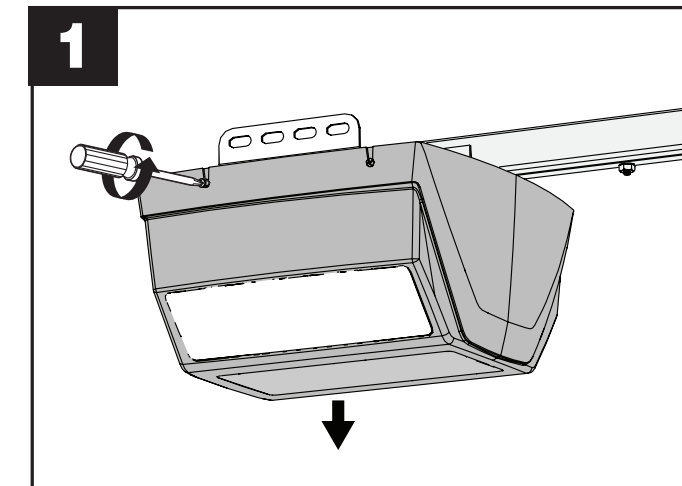

Loosen the 4 housing screws (no need to completely remove them) and remove the housing.

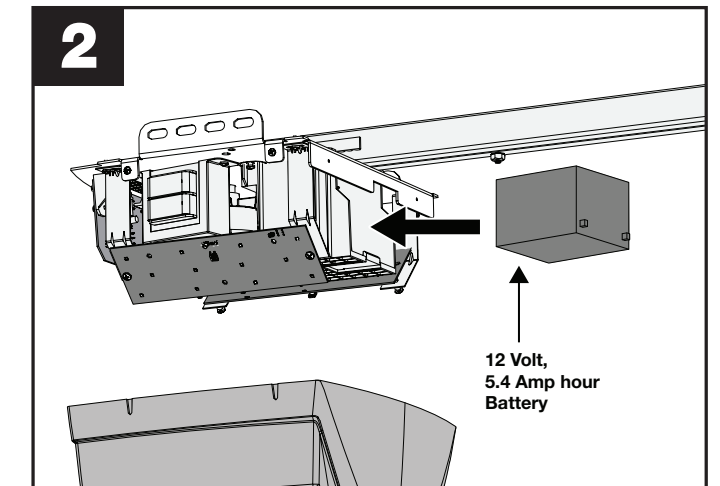

From the front of the unit, remove old battery and insert the new battery into the battery holder until it snaps into place.

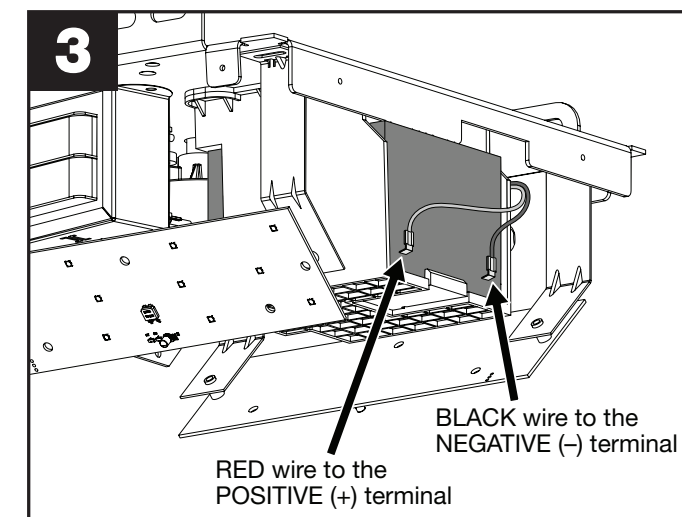

Connect the operator power leads to the battery terminals. Make sure the RED wire is connected to the POSITIVE terminal and the BLACK wire is connected to the NEGATIVE terminal.

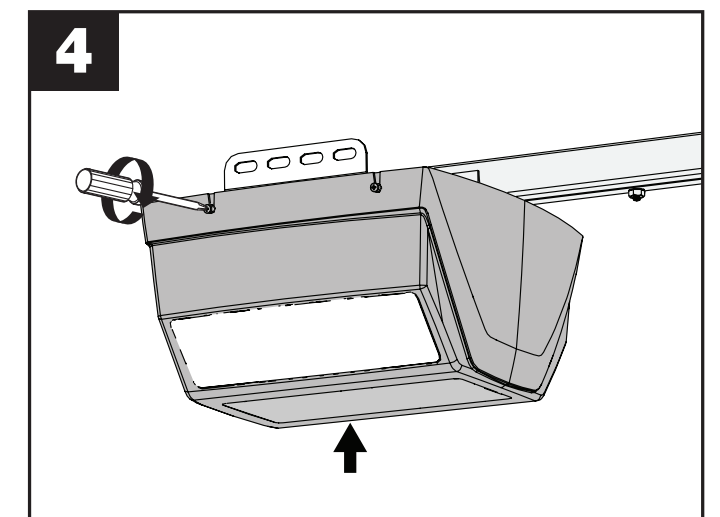

Replace housing and tighten screws.

⚠ WARNING

KEEP BATTERIES OUT OF REACH OF CHILDREN. Swallowing batteries can lead to serious injury or death. If you suspect someone has swallowed a battery, go to the hospital immediately. Do not induce vomiting or eat or drink anything.

For more information, call the National Battery Ingestion Hot line: 202-625-3333.

The battery identification number for this product is MMB100.

CONNECTING POWER

WARNING

- To prevent electrocution or fire, installation and wiring must be in compliance with local electrical and building codes.
- To reduce the risk of electric shock, this equipment has a grounding type plug, that has a third (grounding) pin. This plug will only fit into a grounding type outlet. If the plug does not fit into the outlet, contact a qualified electrician to install the proper outlet. Do not change the plug in any way.
- Never use an extension cord or change the plug in any way.
- This product is only intended for use with the supplied power cord. If a suitable grounded outlet can not be reached with the supplied power cord, contact a licensed electrical contractor to install an outlet.

For Grounded Outlet Connection

1. Plug in the power cord into an electrical outlet within 3 feet of the opener. If you do not have a grounded electrical outlet within 3 feet of your garage door opener call a licensed electrician to install one.
2. Coil excess cord and tape or zip tie it to the top of the power head away from moving parts.

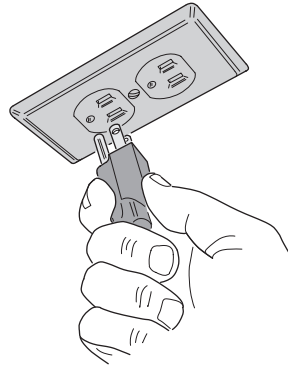

TEST THE WALL STATION

With the garage door opener head unit's AC power cord plugged into an outlet, test the wall station to see it is working properly by using it to operate the light.

- Wait a few moments until the LED on the Wall Station comes on.
- Press the light button to turn the light on and off.

If you are unable to operate the garage door operator's light using the Wall Station's buttons, please go to the Wall Station Troubleshooting section on page 33.

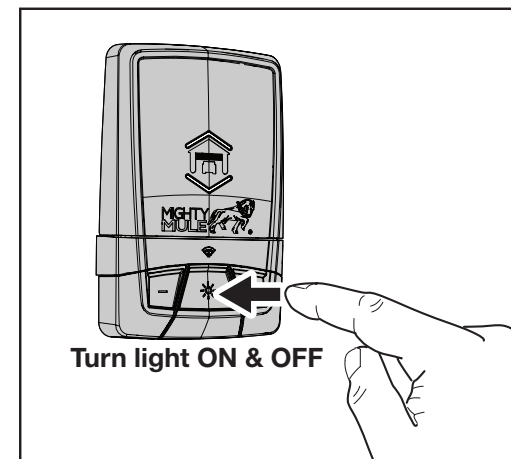

ALIGNING PHOTO BEAMS

NOTE: If the door remains idle for 5 minutes, the beam LED will turn off to save power. The beam power turns on for 5 minutes when door moves down to the fully closed position. The beam power can be restored for 5 minutes by pressing the light button on the wall station.

The photo beam has two components, a sender and a receiver. The sender produces a narrow infrared beam that travels across the bottom of the door opening to the receiver.

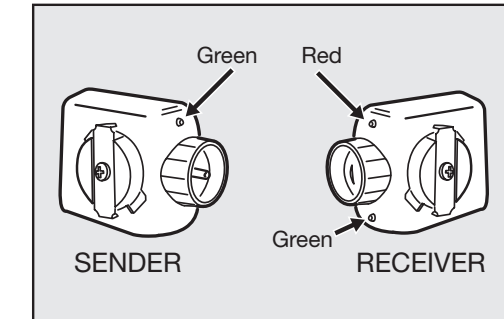

Aligning the Infrared Photo Beam

1. A lit GREEN LED indicates that the photo beams have power.
2. Adjust the beams so that the sending unit and receiving unit are aligned. When the RED LED lights up the photo beams are aligned.
3. If an object blocks the infrared beam while the door is closing, the door will stop, then reverse and fully open (the opener's light will flash three times).
4. As a safety feature, the opener will ignore signals from all remote controls if the door is open and the photo beam is blocked or out of alignment. In this case, the door can be forced closed by pressing and holding the wall station's button (be sure the door area is in clear view).

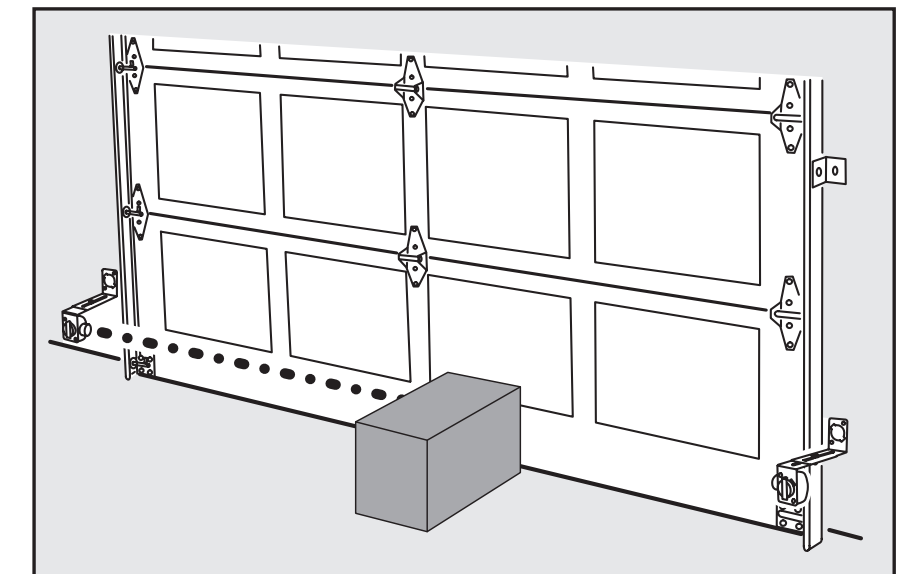
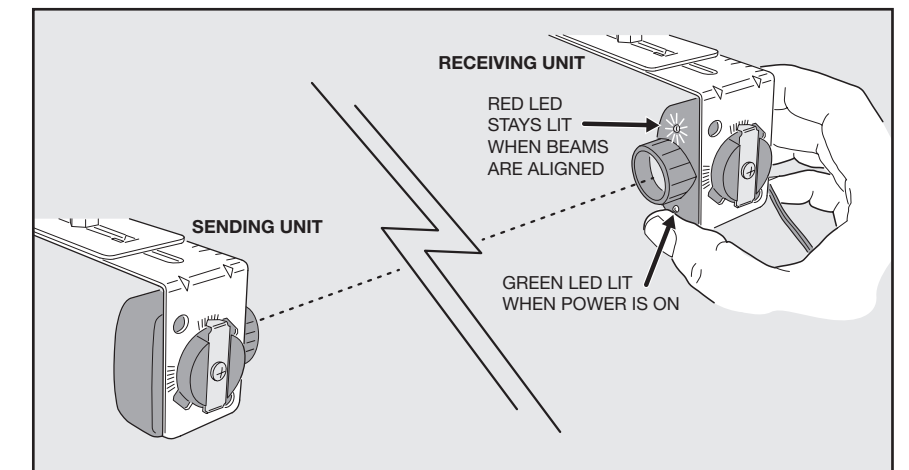

PROGRAMMING OPENER AND CONTROLS

PROGRAMMING TRAVEL LIMITS

Adjusting the Open and Close Limits

The limit settings control how far the door will open and close. Set the limits so the door opens just short of any door stops, and closes at the floor level. Use the wall station or a transmitter to test operate the door. If required, use the following steps to adjust the limits.

NOTE: If the door does not open or gives an error, adjust the force factor as shown on page 25.

SETTING THE OPEN LIMIT

- ➔ **UP +** PRESS LEARN & UP
- ➔ **DOWN -** FOR 3 SECONDS
- ➔ **LEARN**
- 2 GREEN FLASHES = SET UP LIMIT
- ➔ **UP +** PRESS UP (+) OR DOWN (-)
- ➔ **DOWN -** TO JOG THE DOOR TO THE
- LEARN** CORRECT POSITION
- UP +**
- DOWN -** PRESS LEARN TO STORE LIMIT
- ➔ **LEARN**
- 2 GREEN FLASHES = OPEN LIMIT STORED

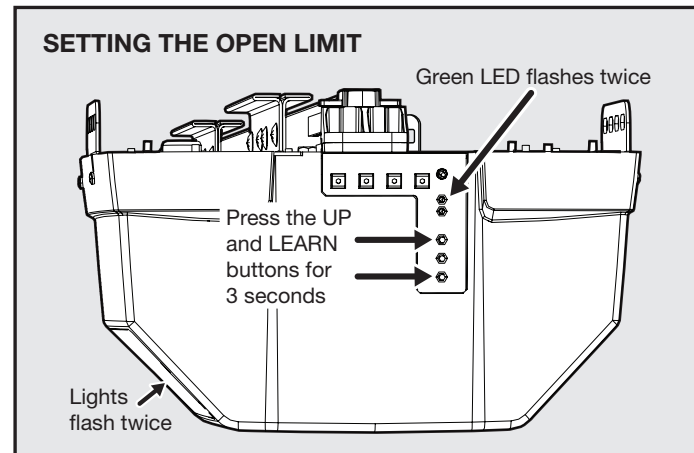

SETTING THE CLOSED LIMIT

- ➔ **UP +** PRESS LEARN & DOWN
- ➔ **DOWN -** FOR 3 SECONDS
- ➔ **LEARN**
- 2 RED FLASHES = SET DOWN LIMIT
- ➔ **UP +** PRESS UP (+) OR DOWN (-)
- ➔ **DOWN -** TO JOG THE DOOR TO THE
- LEARN** CORRECT POSITION
- UP +**
- DOWN -** PRESS LEARN TO STORE LIMIT
- ➔ **LEARN**
- 2 RED FLASHES = CLOSE LIMIT STORED

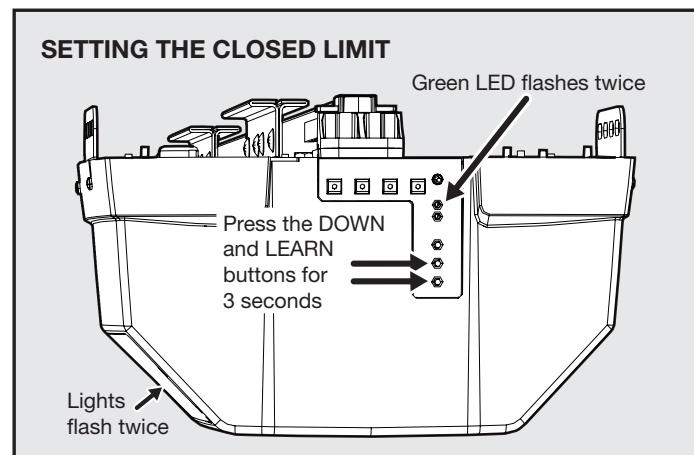

SETTING THE DOOR FORCE

- RUN THE OPERATOR SIX COMPLETE UP & DOWN CYCLES
- THE OPERATOR AUTOMATICALLY SETS THE CORRECT DOOR FORCE

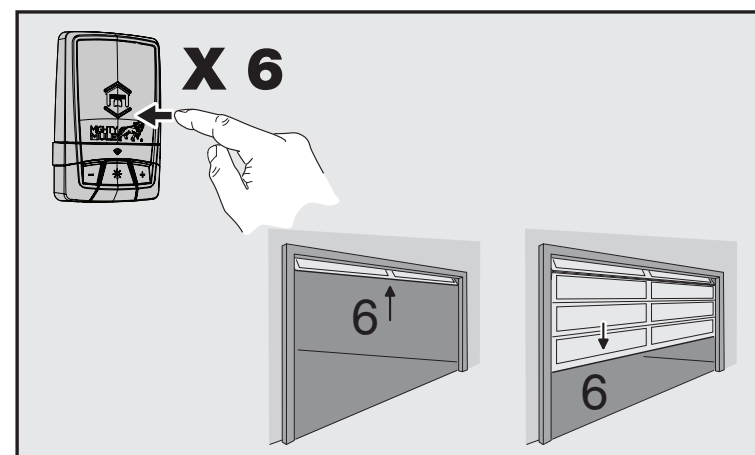

SAFETY REVERSAL SYSTEM TEST

⚠ WARNING

Always perform the Safety Reversal System Test after making any adjustments to the opener.
PERFORM THE SAFETY REVERSAL SYSTEM TEST MONTHLY!

The opener determines that there is an obstruction if a higher than expected amount of force is detected during a door cycle. If an obstruction is encountered during a closing cycle, the opener and door will stop then fully open. If an obstruction is encountered during an opening cycle, the opener and door will stop.

1. With the door in the open position lay a 2"x4" board flat on the floor where it will be struck by the center of the door as it closes.
2. Activate the garage door opener using the wall station.
3. Verify that the door reverses when it strikes the board. The door must reverse within two seconds after striking the board.

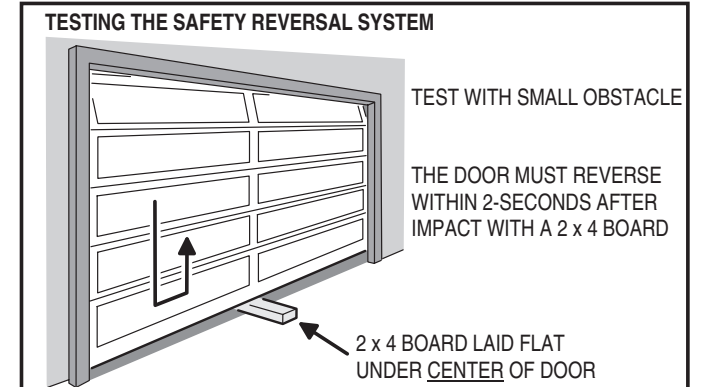

PROGRAMMING REMOTES

The opener is supplied with two three-button remote controls (the second and third buttons can be used to control an additional opener or gate if it contains a compatible receiver). Additional single and multi-button remote controls can be purchased. The short wire on the back of the opener serves as an antenna for the remote controls. **Do not cut off the wire.**

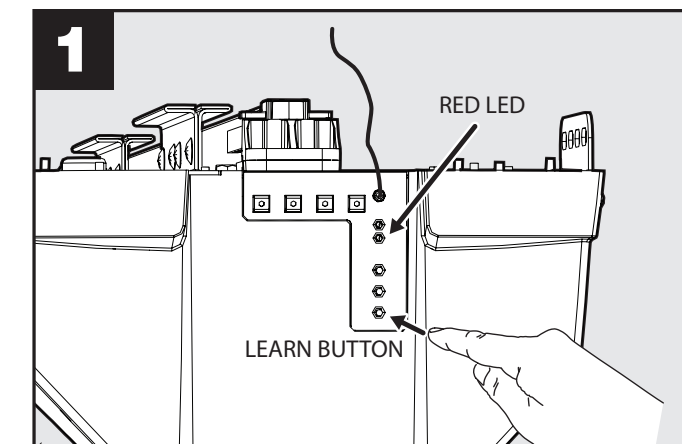

Press and release the opener's LEARN BUTTON.
Note: Pressing longer than 1 second will erase all programming. The opener should BEEP and the LIGHT should BLINK once. The RED LED will remain lit in Learn Mode for 15 seconds.

Repeat Steps 1 & 2 for any additional remote controls or buttons.

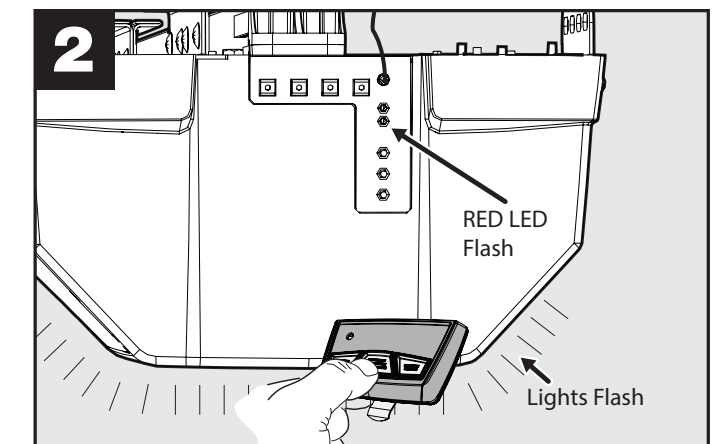

Send a signal from the desired button on the remote. The opener's light and the red LED will flash once if a remote was added.

DELETING A REMOTE FROM THE GARAGE DOOR OPENER

If a remote is already programmed to the opener and you want to delete it, follow the same procedure as PROGRAMMING REMOTES above. The opener will recognize the remote and delete it from memory. The RED LED and LIGHT will blink 4 times to show the REMOTE was successfully deleted.

TESTING THE REMOTE

Before testing the remote control, straighten out the opener's antenna wire so it points up.

Stand clear of the door, press the remote control's button and verify that the opener starts. PRESS THE REMOTE CONTROL'S BUTTON AGAIN TO STOP THE DOOR MID-TRAVEL.

INSTALLING AND PROGRAMMING KEYPAD (if applicable)

DESCRIPTION:

To activate the garage door opener, the user enters their unique 1 to 6 digit long code on the unit's keypad and presses the up/down (⬆️) button. For up to 30 seconds after the last activation, the keypad can be re-triggered by simply pressing the up/down (⬆️) button again. This allows the user to stop or reverse the opener quickly, without having to re-enter their code.

The keypad has built-in lighting for use at night or in dark areas. The clear silicone keys are back-lit with a pleasing blue glow. Pressing any key will activate the back-light.

The keypad lockout timer will disable the keypad after 10 unsuccessful activations. The keypad must remain idle for 30 seconds before new attempts.

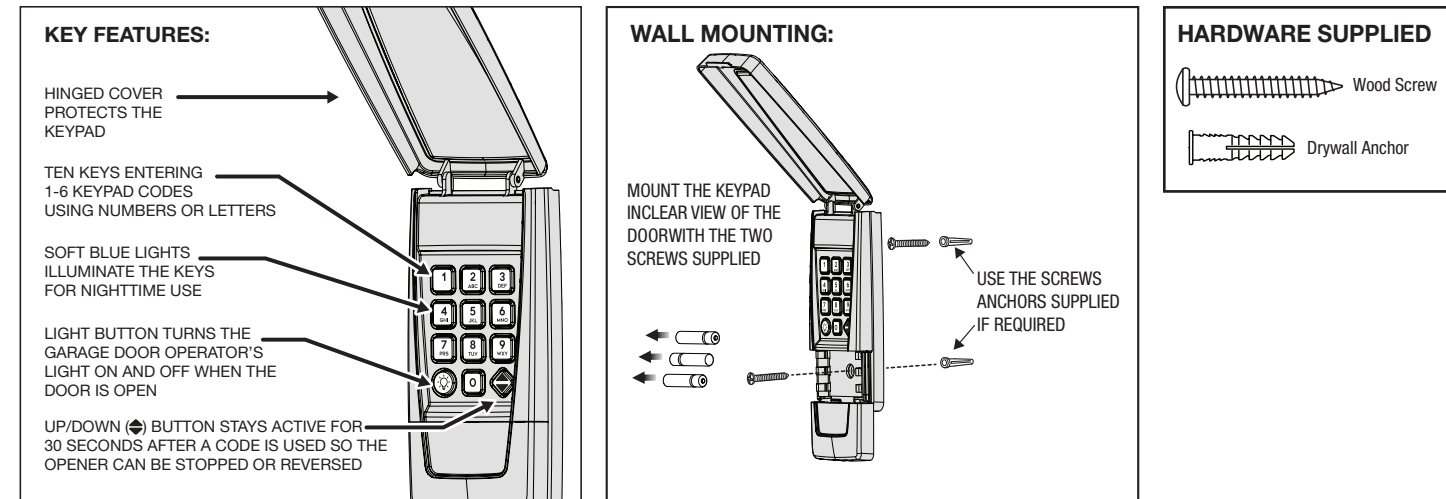

IMPORTANT: Batteries must be installed before programming can begin. See page 31.

PROGRAMMING A KEYPAD CODE TO THE GARAGE DOOR OPENER

- 1 Press and release the opener's LEARN BUTTON.
Note: Pressing longer than 1 second will erase all programming.
- 2 While the RED LED is lit, enter a 1-6 digit code into the keypad. Then PRESS and HOLD the keypad's up/down (⬆️) button until the opener BEEPS and the light BLINKS once.

Repeat Steps 1 & 2 for any additional keypad codes.

DELETING A KEYPAD CODE

To delete a keypad code that you no longer want follow the same steps above. The opener will recognize the code and delete it from memory. The RED LED and LIGHT will blink 4 times to show the code was successfully deleted.

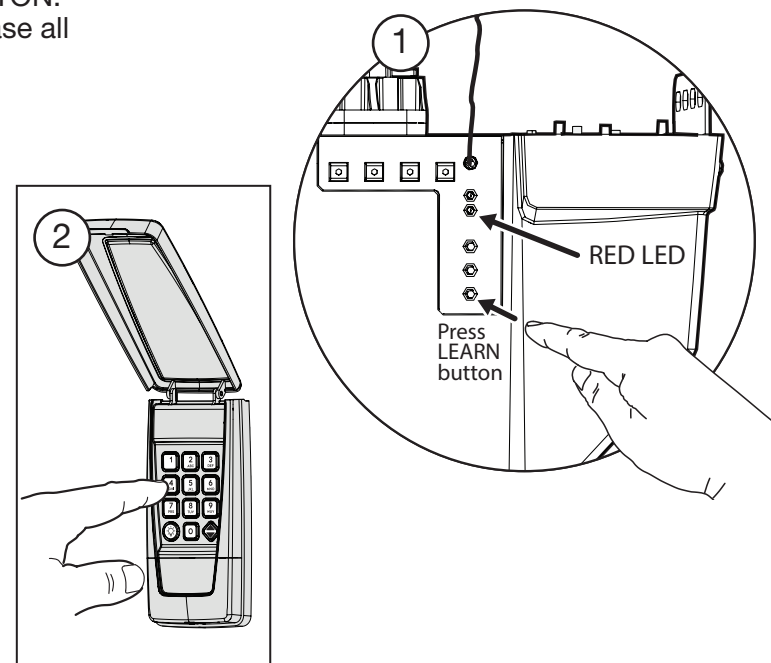

Adjusting the Force Factor (Installation Option, Normally Not Used)

The opener uses the peak force measured during each of the last four complete cycles plus a "force factor" to calculate the maximum allowed force setting for the current door cycle. If the calculated maximum force setting is exceeded during the current door cycle, the opener reacts to the obstruction. As door hardware conditions change over time with weather and wear, the calculation of the maximum door force setting using the four cycle running average will compensate for the current conditions of the installation.

⚠️ WARNING

DO NOT increase force to overcome a worn or damaged door.

Changing the Force Factor Setting

As an installation option, the opener's "force factor" can be adjusted to change the amount of pressure exerted on an obstacle before the opener reacts to the obstruction.

- 1 Press both the UP and DOWN buttons for three seconds. The red and green indicators and opener's light will flash twice.
- 2 Use the UP or DOWN buttons to set the force factor. Pressing the UP button increases the force factor, pressing the DOWN button decreases the force factor.

- 3 After selecting the force factor, press the LEARN button to store the setting and exit setup. The red and green indicators and the opener's light will flash two times. (If the force factor is not set within one minute, the opener will return to normal operation at its previous force factor setting.)
- 4 **After changing the force factor setting, perform the Safety System Reversal Test.**

FORCE FACTOR INDICATOR TABLE

GREEN ON	LOW FORCE FACTOR
RED & GREEN ON	MEDIUM FORCE FACTOR
RED ON	HIGH FORCE FACTOR

⚠️ WARNING

IMPORTANT USER SAFETY INSTRUCTIONS

A MOVING GARAGE DOOR CAN CAUSE INJURY OR DEATH! TO REDUCE THE RISK OF DEATH OR SEVERE INJURY:

- 1 READ AND FOLLOW ALL INSTALLATION INSTRUCTIONS.
- 2 NEVER LET CHILDREN OPERATE, OR PLAY WITH DOOR CONTROLS! KEEP REMOTE CONTROL AWAY FROM CHILDREN!
- 3 Always keep moving door in sight and away from people and objects until it is completely closed. NO ONE SHOULD CROSS THE PATH OF THE MOVING DOOR.
- 4 NEVER GO UNDER A STOPPED, PARTIALLY OPEN DOOR.
- 5 Test door opener monthly. The garage door MUST reverse on contact with a 1-1/2 inch object (or a 2x4 board laid flat at the center of the door) on the floor. If adjusting either the force or the limit of travel, re-test the door opener. Failure to adjust the opener properly may cause severe injury or death.
- 6 If possible, use the red emergency release handle only when the door is closed. Use caution when using this release with the door open. Weak or broken springs may cause the door to fall rapidly, causing injury or death.
- 7 KEEP GARAGE DOORS PROPERLY BALANCED. (See Garage Door Opener Maintenance) An improperly balanced door could cause severe injury or death. Have a qualified service person make repairs to cables, spring assembly and other hardware.
- 8 To reduce the risk of injury to persons - Only use the WiFi wall station for unattended operation when installed with a sectional residential overhead door.
- 9 **SAVE THESE INSTRUCTIONS.**

USING THE GARAGE DOOR OPENER

Opening the Door

- 1 With the door in view, press the wall station's UP/DOWN button or the button assigned to the opener on the remote control, or enter a valid access code and press (◆) on a wireless keypad.
- 2 When the opener is activated, the opener's light will turn on and the door will begin to open.
- 3 The door will open until the open limit is reached. If an obstacle is encountered while the door is opening, the door will stop and opener's light flashes four times.
- 4 The opener's light will stay on for about five minutes after the door stops.

Closing the Door

- 1 With the door in view, press the wall station's button or the button assigned to the opener on the remote control, or enter a valid access code and press (◆) on a remote keypad.
- 2 When the opener is activated, the opener's light will turn on and the door will begin to close.
- 3 The door will close until the close limit is reached. If an obstacle is encountered, the door will stop and reverse to open and the opener's light flash four times. If the safety beam is interrupted during closing, the door will stop and reverse to open and the opener's light will flash three times.
- 4 The opener's light will stay on for about five minutes after the door stops.

Stopping the Door Mid-travel

- 1 The door can be stopped immediately at any time by pressing the wall station's UP/DOWN button, the remote control's pushbutton, or press the (◆) button on a remote keypad (if the remote keypad was used to start the door).
- 2 The next time the opener is activated, the door will move in the opposite direction.

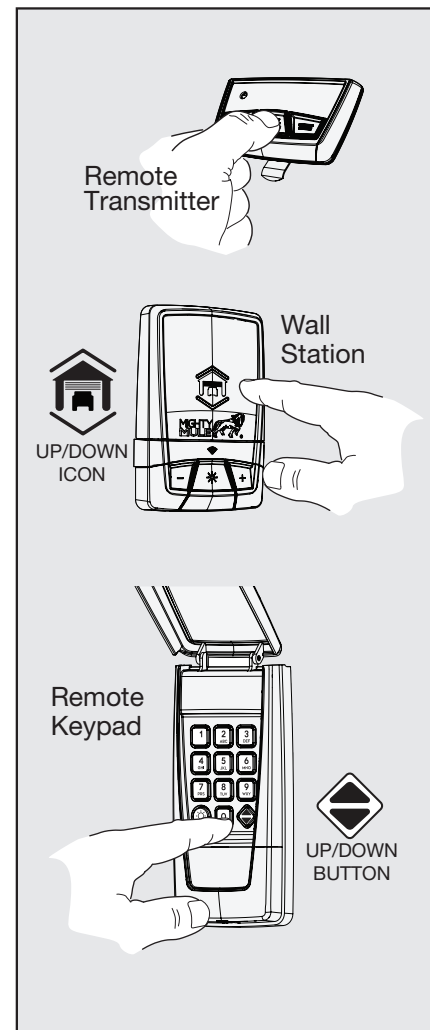

MANUAL DISCONNECT

Disconnecting the Door from the Opener

- 1 With the door in any position (preferably closed), carefully pull the red release handle. USE CAUTION IF THE DOOR IS OPEN, THE DOOR MAY DROP.
- 2 The disconnected door can be opened or closed manually.
- 3 To re-connect the opener, flip the release lever up. Raise or lower the door manually until the opener reconnects.

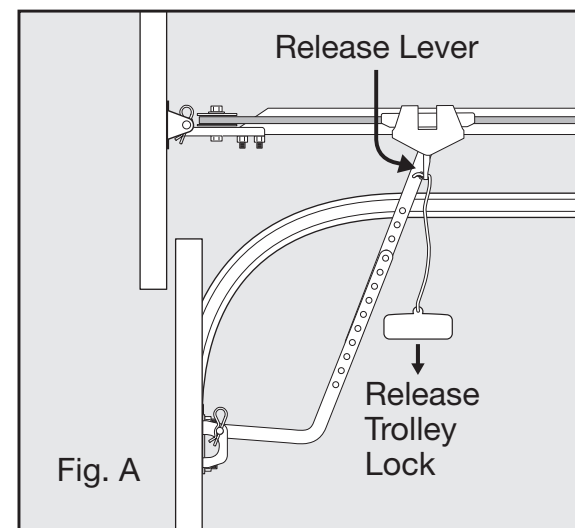

USING THE WALL STATION

Vacation Lock for Additional Security

- 1 Open the wall station's cover to access the Programming Buttons. Press the LOCK (🔒) button on the MMW200 and slide the LOCK SWITCH to (🔒) on the MMW100 to prevent remote controls from opening the door after the door is completely closed. When the Vacation Lock is activated, the remote controls can close the door, but not open it. The door can still be opened or closed by using the wall station's UP/DOWN pushbutton.

NOTE: To signal that the vacation switch is locked, the opener's light will flash and the alarm will sound five times if a remote control is activated in an attempt to open the door.

- 2 Press the wall station's LOCK (🔒) button again on the MMW200 and slide the LOCK SWITCH to (🔓) on the MMW100 to unlock and return the operator to normal operation.

NOTE: The Vacation Lock can be set and reset using the Smart app on a smart phone when used with the MMW200 Smart control wall station.

Wall Station Reset for WiFi Wall Station (MMW200)

If you change your home router or password you will need to RESET your Wall Station.

- 1 To do a Wall Station RESET press the WiFi Link (🌐) button for 10 seconds, the RED LED blinks and then turns solid RED. The Wall Station is now ready to re-link to a new or updated home router.
- 2 To re-boot the Wall Station for software updates, press the RESET (🔄) button.

Controlling the Opener's Light

- 1 The opener's light can be turned ON by pushing the wall station's light on/off (☀️) button. The light will stay on until the button is pressed again or the opener is cycled.
- 2 To DECREASE the light brightness, press the dimmer (-) button.
- 3 To INCREASE the light brightness, press the brighter (+) button.

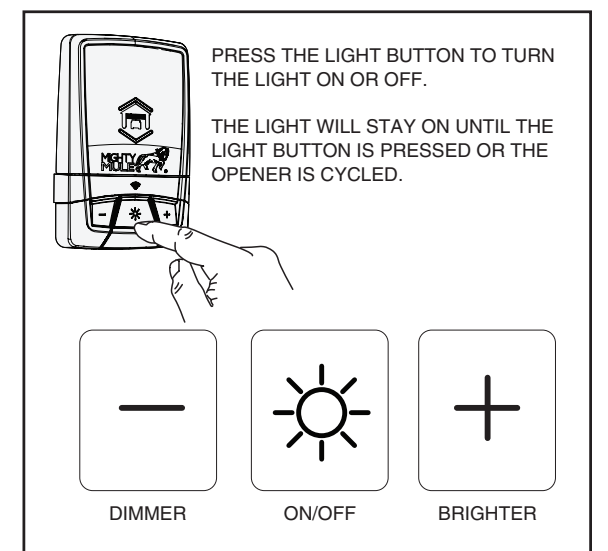
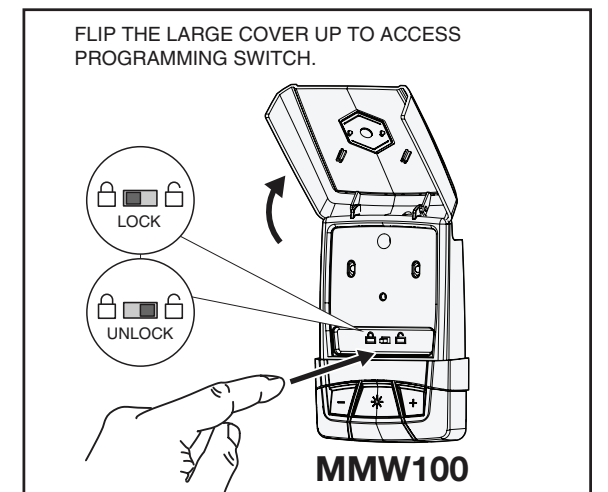
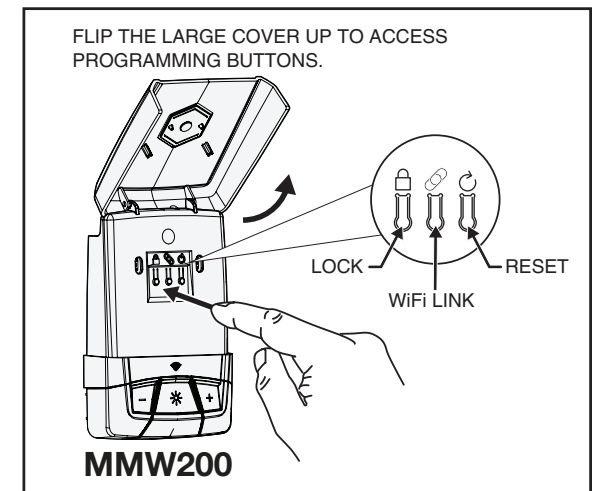

Mighty Mule Smart Control APP

After you complete the opener installation and everything is working correctly, use your smart phone to Download, Register and Activate the Mighty Mule Smart Control APP.



Use your smart phone to download and install the “Mighty Mule Smart Control” app. On initial use you’ll be asked to register and create an account. Once complete, sign in with your new account information.

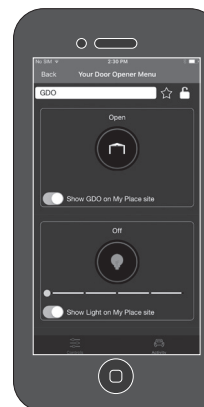
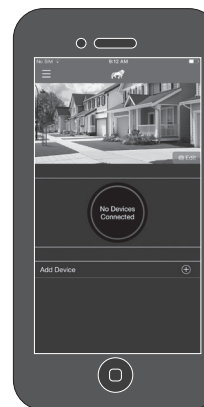
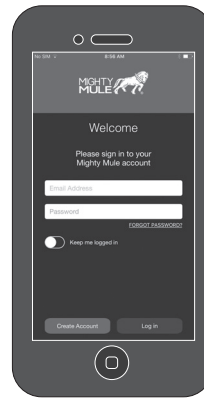

Add Your Device

You’ll need to be beside the Smart Control Wall Station to add your devices (garage door and light). Begin by tapping the plus sign at the bottom right of the screen. The app will walk you through the process from there. When complete two devices will show in your app site — a garage door and a light.

Use the Smart Control App

The app’s main screen indicates the current state of the garage door and allows operation. To close or open the garage door, tap the garage door icon. Likewise, tap the light icon to turn the garage door light on or off.

For a detailed view of the device, single tap information icon (!). From here you can operate your device, remove a device, adjust the brightness of the light, and you can view a history of who operated the device.

Manage Your Devices and Members

Tap the Site Menu icon (three lines stacked on top of each other) located in the top left of the screen. From here you can invite new members to join your site and remove existing members from your site.

Invite Others

To invite a new member, select the Invite New Member button at the bottom of the Site Menu.

You will be asked to set their permission level. There are three classes of members in this application:

- You, the Smart Control App owner, who created the site and added devices.
- Administrators, who can invite others, set/change permissions, and operate and view all devices.
- Regular members, who can operate and view only specified devices.

For additional support visit mightymule.com

PHOTO BEAM TEST

- 1 Check that the opener has power. The green LEDs on the sender and receiver should be lit.
- 2 If the receiver’s green LED is on, but the red LED is off, the receiver has power but is not detecting the infrared beam from the sender. The red LED might flash when the beam is partially detected. This can be caused by mis-alignment or something blocking the beam. Adjust the photo beam sender and receiver while watching the receiver’s red LED (stay out of the beam while aligning it). When the red LED stays on, rotate the sender towards the ceiling and stop when the red LED on the receiver begins to flicker. Rotate the sender back towards a horizontal position with the floor and stop as soon as the red LED on the receiver lights solid. The beam is now properly aligned.

NOTE: If the receiver’s red LED remains off, check for: 1) Dirt on the receiver’s lens, 2) Sunlight shining into the receiver’s lens, 3) A short in the photo beam wiring (from staples or at the opener terminals).

- 3 With the door closed and the opener disengaged (Fig. A) from the door, press the wall station’s button to move the traveler (the part on the belt or chain that the trolley engages with) to the up position (away from the door).

NOTE: Do not cycle the opener to full travel without the door connected.

- 4 Push the wall station’s button again. While the traveler is moving to the down position (toward the door), block the photo beam. THE TRAVELER MUST STOP, THEN REVERSE TO THE UP POSITION. The opener’s light should flash three times.

- 5 Place an object in the path of the photo beam. Check that constant pressure is required on the wall station’s button to cause the traveler to move toward the down position. Release the button before the opener stops; check that the traveler returns to the up position.

NOTE: The garage door opener will not respond to a CLOSE command from a radio transmitter if the photo beam is blocked.

- 6 To reconnect the opener, flip the release lever up. Raise the door manually until the opener reconnects.

PHOTO BEAM INDICATOR TABLE	
GREEN ON	POWER ON
GREEN OFF	POWER OFF
RED ON	BEAM OK - NO BLOCKAGE
RED OFF	BEAM BLOCKED OR MIS-ALIGNED
RED FLASHING	BEAM ALIGNED POORLY

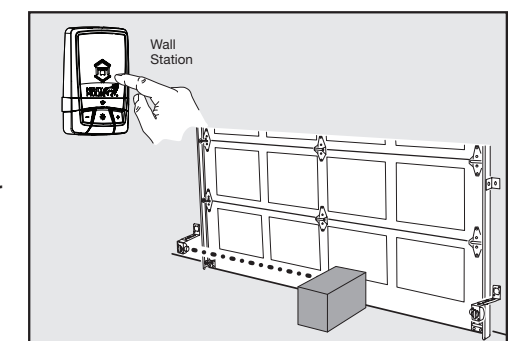
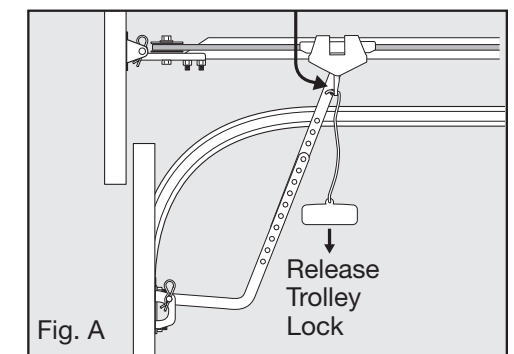

REPLACING REMOTE BATTERY:

When the red light on the remote glows dimly, or fails to light at all when the remote is activated, the batteries need replacing.

Open the remote's case.

Remove the circuit board.

Replace old battery with new Type CR2032 battery.

Re-assemble the remote.

REPLACING THE REMOTE CONTROL BATTERY

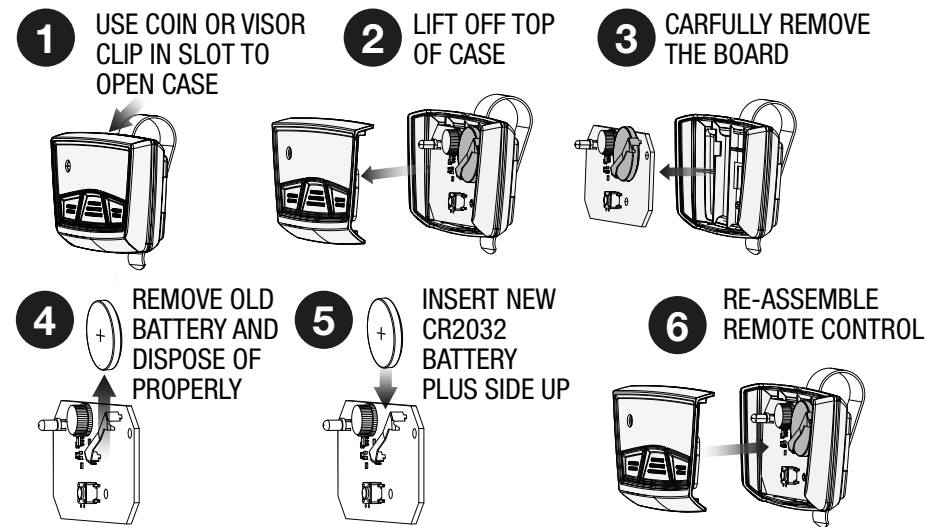

INSTALLING OR REPLACING KEYPAD BATTERIES:

Remove the two screws and slide the battery cover off.

Remove the 3 old AAA batteries and dispose of them properly.

Install 3 fresh AAA alkaline batteries.

Replace the battery cover and re-install the two screws.

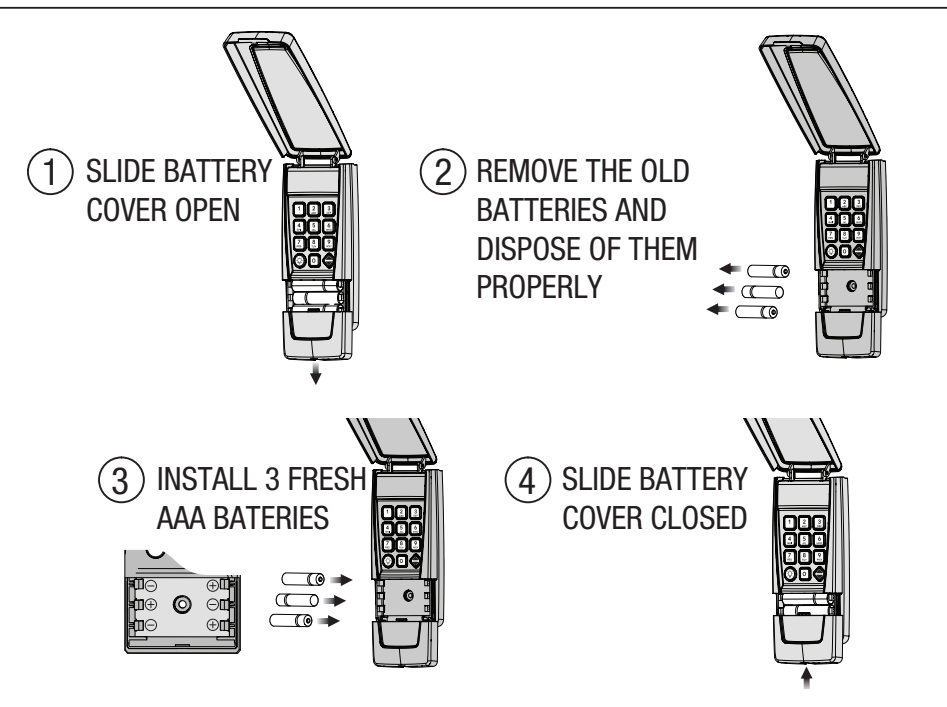

⚠ WARNING

KEEP BATTERIES OUT REACH OF CHILDREN. Swallowing batteries can lead to serious injury or death. If you suspect someone has swallowed a battery, go to the hospital immediately. Do not induce vomiting or eat or drink anything.

For more information, call the National Battery Ingestion Hot line: 202-625-3333.

The battery identification number for this product is CR2032, or AAA Alkaline (LR03).

MAINTENANCE AND ADJUSTMENTS

Garage Door Opener Maintenance

Weather conditions may affect the door operation which could require some re-setting of the opener's adjustments. Doors may swell and become heavier during wet periods, door hinges and rollers might bind during cold periods. To insure safe operation of the door, perform the following tests, including any additional test steps described.

Every Month

- 1 With the door closed, pull the red release handle to disconnect the opener from the door.
- 2 From outside the garage, slowly open the door manually all the way, and then close it all the way. Notice if there is any binding, sticking or rubbing. The door should move smoothly in both directions.
- 3 Raise the garage door about halfway up. Carefully release the door and see if the door balances. It should stay in place. Close the door.

NOTE: If the garage door is unbalanced or the door travel isn't smooth, have a qualified garage door professional adjust or repair the door.

- 4 To reconnect the opener, flip the release lever up and run the opener.
- 5 Perform the Safety Beam Test – page 29.
- 6 Perform the Safety Reversal System Test – page 23.

After Servicing the Opener

- 1 Perform the Safety Beam Test – page 29.
- 2 Perform the Open and Close Limit Adjustments – page 22.
- 3 Perform the Safety Reversal System Test – page 23.

Every 6 Months

Check the belt tension. The tension spring in the traveler keeps the belt taut. The factory setting for the tension spring length is .9" long. If the tension spring is longer than 1", adjust the belt – page 7.

- 1 Hold the traveler so the adjustment wheel is visible through the large slot.
- 2 Use a flat blade screwdriver to turn the adjustment wheel to compress the tension spring until its length is between .9" and 1" long.

Every Year

Check the door hardware for lubrication needs. Lubricate door hinges, rollers and bearings according to door manufacturer's recommended procedures.

TROUBLESHOOTING

Door Operation Troubleshooting

These conditions occur when the door is in motion or while attempting to move the door. Feedback is given via light flashes and an audible alarm once the door stops travel.

⚠ WARNING
If a battery backup is used, the opener may start moving the door even with AC power disconnected. Use Caution when servicing.

Flash/Beep Trouble Code	Problem	Cause	Remedy
1	No Problem	Remote control entered into memory	Add any additional remote controls
2	Door won't operate	Shorted wall station wires	Check wall station wires. Be sure both are connected to the terminal screws. Check for a staple in the wall station wires. Remove any staples compressing the wire. Check for frayed wires.
3	Door won't close	Safety beam obstacle	Check for obstacles. Align the safety beams.
4	Door reverses or won't open or close	Open or close force exceeded	Check for obstruction or binding of the garage door. Adjust force factor if necessary. Perform a field reset if necessary.
5	Door won't open from remote control	Remote was activated while in vacation mode	Activate vacation mode switch on wall station to exit vacation mode.
6	Limit error	Down limit and up limit are set too close together	Re-set the open and close limits. If error occurs again, contact a qualified garage door professional.
7	Door reverses or won't open or close	Encoder has detected an error	Check for obstruction or binding of the garage door. If error occurs again, contact a qualified garage door professional.

Troubleshooting Smart Control Wall Station

WALL STATION TROUBLESHOOTING		
Condition/LED Color	Possible Cause	Possible Solution
Wall station does not power on.	1. Incorrect wiring	1. Check wall station wiring for correct polarity. 2. Confirm head unit is plugged in and has power. 3. Call tech support.
RED	1. Wall station has not been assigned to an access point. 2. Wall station is not within range of its assigned access point. 3. Antenna damaged or obstructed.	1. Use the mobile app to configure the wall station's access point. 2. Relocate the wall station or relocate the homes access point. 3. Call tech support.
YELLOW	1. Checking for updates	1. No action required from user; this behavior is normal and temporary.

LEDs on the Smart Control Wall Station

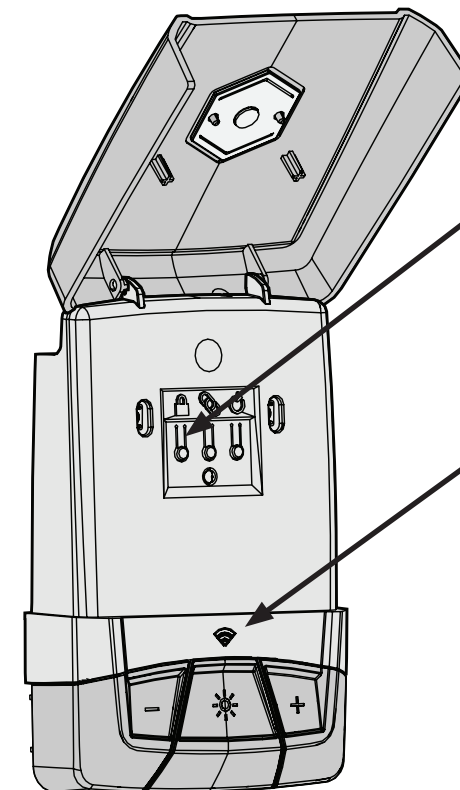

The Smart Control Wall Station has two LEDs that convey information at a glance.

The top LED provides information on the vacation mode.

Vacation Mode LED	
ON	Normal operation
FLASHING	Vacation mode enabled

The bottom LED indicates the status of the Wi-Fi connection and device.

COLOR	LED STATUS	CONDITION
Blue	Solid	Unit has power / initial state prior to the wall station connection to operator
Red	Solid	Offline
Red	Flashing	Attempting to connect to access point
Yellow	Flashing	obtaining IP address
Green	Flashing	Attempting to connect to cloud server
Green	Solid	Connected
Pink	Flash/Solid	Checking for over the air (OTA) updates up-date (every 6 days)

Transmitter and Keypad Troubleshooting

Ensure the opener is properly functioning from the hard wired wall button or wall station before troubleshooting the transmitter or keypad.

Condition	Possible Cause	Possible Solution
Door not operating	<ol style="list-style-type: none"> 1. Transmitter not learned 2. Transmitter battery low or missing 3. Door not receiving signal 	<ol style="list-style-type: none"> 1. Learn transmitter to opener. See page 22. 2. Press button on transmitter. If LED on transmitter is dim or not lit, replace battery. 3. Press and hold the transmitter button. If the red or green LED indicators on the opener do not blink, verify the following. <ol style="list-style-type: none"> a. Opener antenna wire is straight and routed outside of the cover away from metal and wires. b. Antenna is not damaged, cut, or missing. c. Lock is not enabled on wall station.
Reduced distance of operation	<ol style="list-style-type: none"> 1. Opener is experiencing interference 2. Transmitter battery low 3. Antenna damaged or obstructed 	<ol style="list-style-type: none"> 1a. If the red or green LED indicators on the opener are blinking, there may be a remote nearby with a stuck button. 1b. A device in the home such as a CFL, fluorescent light, plug in power supply, or LED light bulb may cause radio interference, turn off that device and check for improved distance. 2. Press button on transmitter. If LED on transmitter is dim or not lit, replace battery. 3. Check that the antenna wire is straight and routed outside of the cover away from metal and wires. Verify antenna is not damaged, cut, or missing.
Multiple openers moving	Transmitter is learned to multiple openers	Remove transmitter from the desired opener. See page 22.

Battery Troubleshooting

These conditions occur when battery backup is installed, and the door is stopped in the open position. Feedback is given via an audible alarm.

⚠ WARNING

If a battery backup is used, the opener may start moving the door even with AC power disconnected. Use Caution when servicing.

Number of Blinks/Beeps	Condition	Possible Causes	Possible Solutions
2	Low Battery	Battery is low	Check that AC power is connected and allow battery to charge. It will take approximately 10 hours to charge the battery.
4	No Capacity	Battery is no longer holding a charge.	Replace battery now.
5	Battery Shorted	Battery is internally shorted or battery leads are shorted.	Check battery wires for shorting. If wires are OK, replace battery now.

CAUTION

Use caution when installing batteries. Incorrect use can damage the battery, controller or can cause a fire. Only use recommended replacement battery, Mighty Mule MMB100, 12 Volt battery. Unapproved batteries will damage the controller or can cause a fire.

Properly dispose of old batteries.

FCC NOTICE

WARNING: Changes, modifications or adjustments not expressly approved by Nortek Security and Control, LLC could void the user's authority to operate this equipment. There are no user serviceable parts.

NOTICE: This device complies with part 15 of the FCC. Operation is subject to the following two conditions: (1) this device may not cause interference, and (2) this device must accept any interference, including interference that may cause undesired operation of the device.

This device complies with Industry Canada RSS-310. Operation is subject to the following two conditions: (1) this device may not cause interference, and (2) this device must accept any interference, including interference that may cause undesired operation of the device.

Le présent appareil est conforme aux CNR d'Industrie Canada RSS-310. L'exploitation est autorisée aux deux conditions suivantes : (1) l'appareil ne doit pas produire de brouillage, et (2) l'utilisateur de l'appareil doit accepter tout brouillage radioélectrique subi, même si le brouillage est susceptible d'en compromettre le fonctionnement.

LIMITED WARRANTY

This Linear product is warranted to the original consumer against defects in material and workmanship for:

MODEL	ACCESSORIES/ELECTRONICS	PARTS	MOTOR	BELT	LED LIGHTS
MM9 Series	1 year	5 years	Lifetime	Lifetime	Lifetime

This product is warranted to the original consumer against defects in material and workmanship for the periods mentioned above. Mighty Mule will repair, or at its option, replace, any device that it finds requires service under this warranty, and will return the repaired or replaced device to the consumer at Mighty Mule's cost. Devices must be sent to Mighty Mule for service at owner's expense. This warranty does not apply to damage to the product from negligence, abuse, abnormal usage, misuse, accidents, normal wear or tear or due to failure to follow Seller's instructions, or arising from improper installation, storage or maintenance. In no event will Mighty Mule be responsible for incidental, compensatory, punitive, consequential, indirect, special or other damages. The remedies provided by this warranty are exclusive. Some states do not allow the exclusion or limitation of incidental and consequential damages, so the above limitation or exclusion may not apply to you. Any warranties implied by law are limited to the time periods set forth above. Some states do not allow limitations on how long an implied warranty lasts, so the above limitation may not apply to you. This warranty gives you specific legal rights, and you may also have other rights which vary from state to state.

For warranty service and shipping instructions contact Mighty Mule at the phone number shown below. In order to be protected by this warranty, save your proof of purchase and send a copy with equipment should repair be required. All products returned for warranty service require a Return Product Authorization Number (RPA#). Contact Mighty Mule Technical Services at 1-800-543-1236 for an RPA# and other important details.



Mighty Mule Sales: 800-543-4283 • Fax 850-575-8912

Mighty Mule Technical Service: 800-543-1236

For more information on Mighty Mule's full line of Automatic Gate Openers and Access Controls visit www.mightymule.com

Mighty Mule® is the retail brand of Nortek Security and Control, LLC

 **NORTEK**[™]
SECURITY & CONTROL