



a **Nice** brand

# Wireless Vehicle Sensor



## Installation Manual



Know what's below.  
Call before you dig.

# Table of Contents

<b>Kit Contents</b> .....	<b>.2</b>
<b>How it Works</b> .....	<b>.3</b>
1. Program DIP Switch Settings .....	4
2. Determine Location for Sensor and Transmitter Module .....	5
3. Install Sensor and Transmitter Module .....	5
4. Do you have a Mighty Mule MM371W, MM372W, MM571W, MM572W, TS571W, MM271, MM272 or HD272 Automatic Gate Opener? .....	7
Learning an FM130 to an MM371W, MM372W, MM571W, MM572W or TS571W Automatic Gate Opener .....	7
Learning an FM130 to an MM271, MM272 or HD272 Automatic Gate Opener .....	7
<b>Instructions for Installing the Optional RB709U-NB Receiver</b> .....	<b>.8</b>
5. Test the System .....	10
<b>Troubleshooting Guide</b> .....	<b>.11</b>
<b>Limited Warranty</b> .....	<b>.12</b>
<b>FCC Warning</b> .....	<b>.12</b>

## Kit Contents

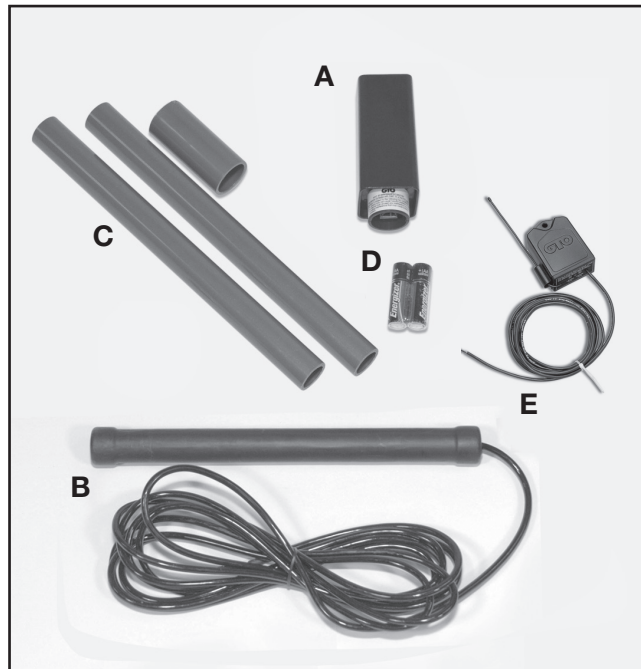

### Kit Includes:

- A. Transmitter Module
- B. Sensor
- C. Mounting Post (3 pieces)
- D. 2 “AA” Batteries *(Note: lithium-alkaline batteries are required for extreme cold climates.)*
- E. Receiver (RB709U-NB)

## How it Works

The electromagnetic sensor detects vehicles in motion and automatically activates your gate. This “hands free” device allows friends, family and delivery personnel to exit your property without the need of an Entry Transmitter, or you, to operate the gate.

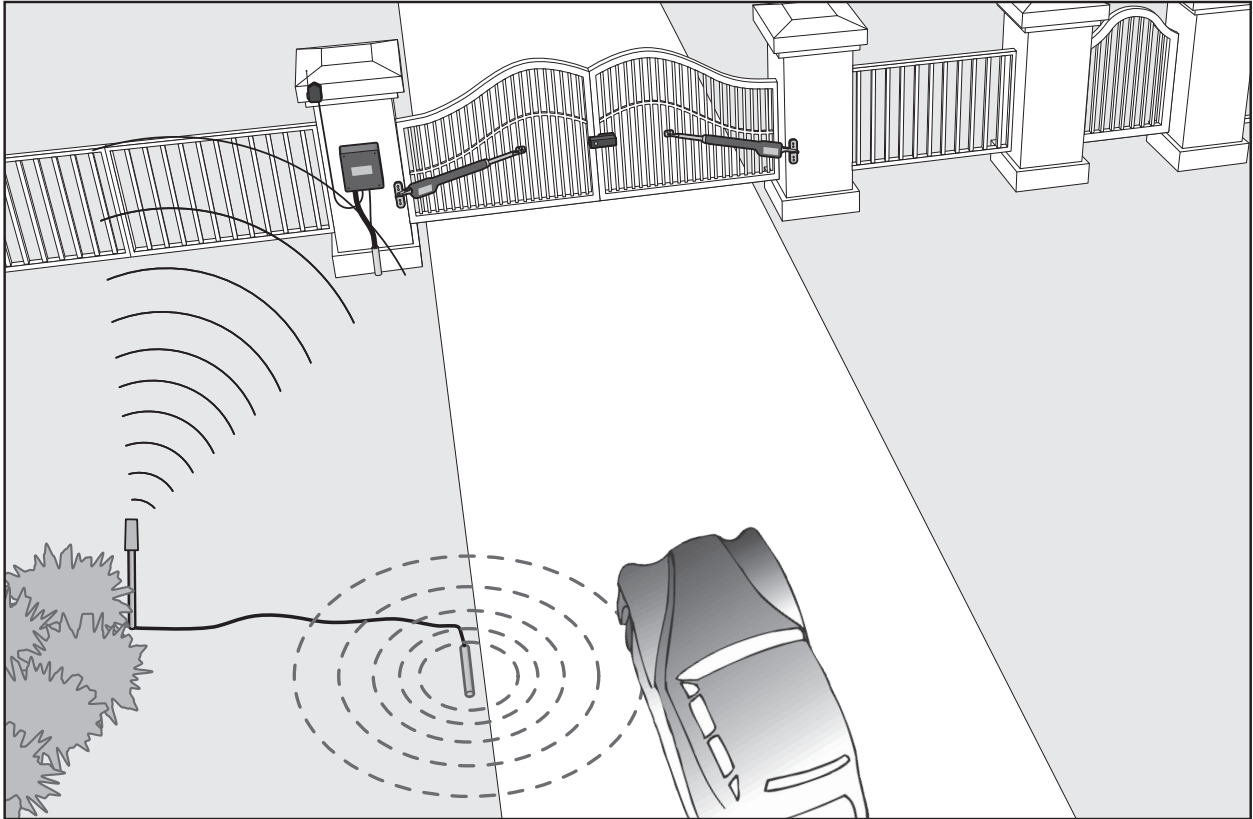

**When a VEHICLE SENSOR is in use, the automatic gate opener could be activated by a child on a bicycle, tricycle or other metal play equipment. DO NOT ALLOW UNATTENDED CHILDREN OR PETS NEAR YOUR AUTOMATED GATE AT ANY TIME.**

# 1. Program DIP Switch Settings

Do you have a Mighty Mule MM371W, MM372W, MM571W, MM572W, TS571W, MM271, MM272 or HD272 Automatic Gate Opener? If so, skip to page 7 for instructions.

**Step 1:** Verify that your Entry Transmitter operates the gate opener.

**Step 2:** Remove the cover (A) from your gate opener Entry Transmitter (B). Remove the cover (C) from the Transmitter Module (D).

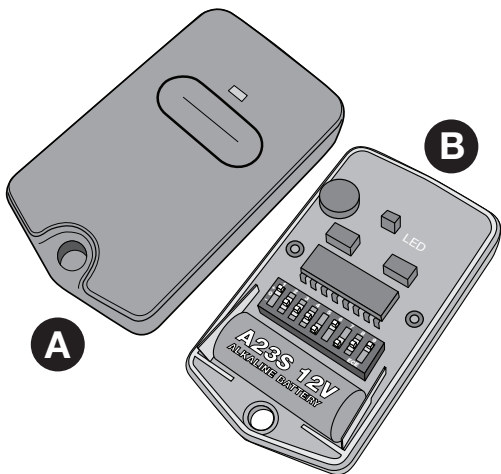

Single Button Entry Transmitter and Cover

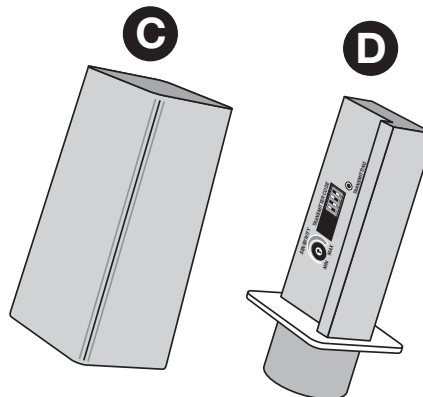

Transmitter Cover and Module

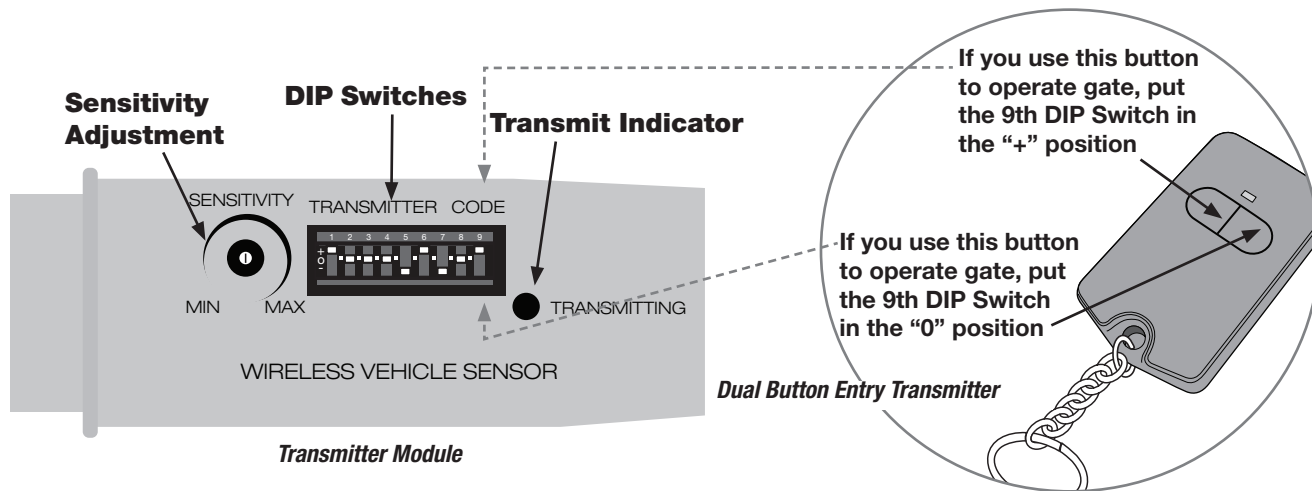

Transmitter Module

Dual Button Entry Transmitter

**Step 3:** You will change the DIP Switch settings on the **Transmitter Module** to match those of your Entry Transmitter. Do not change the DIP switches on the Entry Transmitter.

For **Single Button** Entry Transmitters, set the 9 DIP Switch settings on the Transmitter Module to match the 9 DIP Switch settings of the Entry Transmitter.

For **Dual Button** Entry Transmitters, set the first 8 DIP Switch settings on the Transmitter Module to match the 8 DIP Switch settings of the Entry Transmitter. The 9th DIP Switch setting (Transmitter Module) will depend on which button you use to operate the gate (see illustration above).

## 2. Determine Location for Sensor and Transmitter Module

**NOTE:** Install Transmitter Module and Sensor on the same side of the driveway as your automatic gate opener/receiver.

### Placement of SENSOR:

- No more than 2 ft. from edge of driveway.
- Same side of driveway as the gate opener control box.
- At least 25 ft. from leading edge of open gate, roadways, neighboring driveways, etc.
- Parallel to direction of the driveway.

### Placement of TRANSMITTER MODULE:

- No more than 100 ft. from gate opener receiver.
- Within “line of sight” of the gate opener receiver.
- Away from lawn sprinklers (Transmitter Module is water resistant, not waterproof).
- Away from the driveway edge so that vehicles are unlikely to hit it.

### For Optimum Performance:

- Install the Sensor as far away as possible from power transformers, power lines, underground gas lines and telephone lines.
- Locate the Sensor away from general moving traffic to prevent unwanted activation (the Sensor detects magnetic disturbances caused by a vehicle’s mass and velocity).
- It is recommended that you run the Sensor Cable inside PVC conduit to prevent damage.
- Do not run Sensor Cable in conduit with other wires such as AC power or other control wires.
- THE SENSOR CABLE MUST NOT BE SPLICED.

## 3. Install Sensor and Transmitter Module

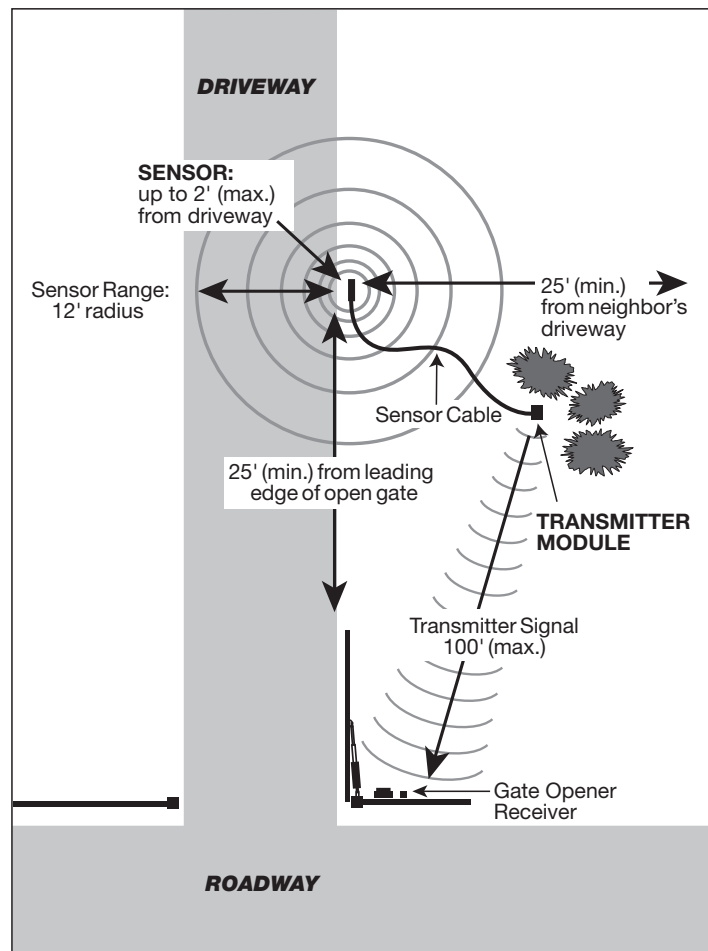

*Sensor Range distance is approximate and will vary due to outside interference, vehicle mass, speed, etc.*

**IMPORTANT:** Clear an area 25 ft. in all directions of metal tools, toys and automobiles that may move to prevent magnetic disturbance during testing and installation.

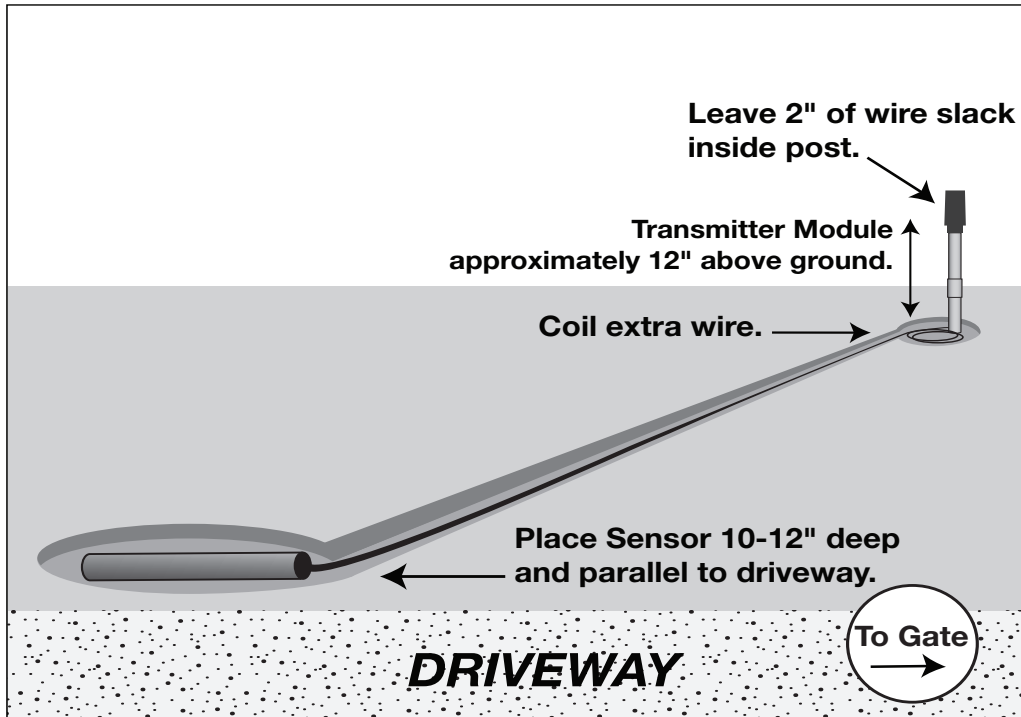

**Step 1:** Dig a hole for the Sensor, 10–12 in. deep and 24 in. long. Be sure the hole is parallel to the direction of the driveway and not more than 2 ft. away from the driveway.

**Step 2:** Dig a trench in which to lay the Sensor Cable from this hole to where you want to install the Transmitter Module. The trench should be at least 6 in. deep to prevent possible wire damage from edgers, lawn aerators, etc.

**Step 3:** Lay the Sensor in the hole parallel to the driveway and the Sensor Cable in the trench. Do not fill/cover the hole or trench until the Transmitter Module signal has been tested (page 5). *If you don't use the full length of Sensor Cable, coil the extra cable beside the Mounting Post.*

**Step 4:** Assemble the Mounting Post using the coupler to connect the two longer pieces.

**Step 5:** Run the Sensor Cable (**B**) through the Mounting Post (**A**) and plug it into the connector at the bottom of the Transmitter Module (**C**). Allow 2 inches of slack in the cable to prevent damage to the connector if Transmitter Module is removed.

**Step 6:** Attach the Transmitter Module to the Mounting Post. At this point, you can put the Mounting Post in the ground, but don't fill the hole until after testing (page 5).

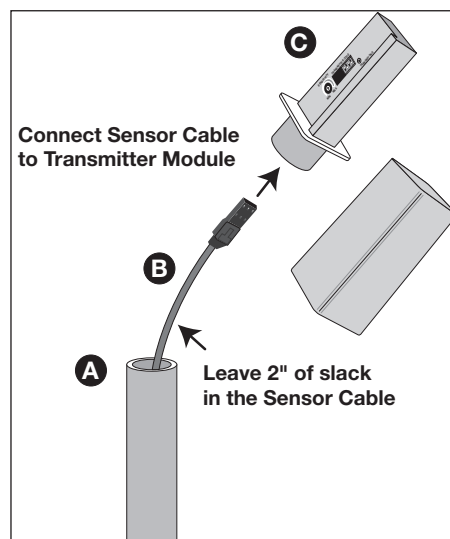

#### 4. Do you have a Mighty Mule MM371W, MM372W, MM571W, MM572W, TS571W, MM271, MM272 or HD272 Automatic Gate Opener?

If so, these openers DO NOT require a receiver. Read the pairing instructions below:

The MM360 and select legacy systems require the installation of the RB709U-NB Universal Receiver. See pages 8-9 for instructions on how to do so.

#### Learning an FM130 to an MM371W, MM372W, MM571W, MM572W or TS571W Automatic Gate Opener.

1. With the power on for your control box, press and hold the gate opener's middle, orange **S3 button** (to the left of "S3" in the diagram) located on the control board until you hear a beep, then release.
2. Take a battery out of the green FM130 transmitter and put it back in. The control board should beep.
3. Test the FM130 by closing the gate and removing and replacing a battery in the green FM130 transmitter. If the gate opens, the FM130 has been properly programmed to your control board.
4. Proceed to page 7: "**Install Sensor and Transmitter Module**".

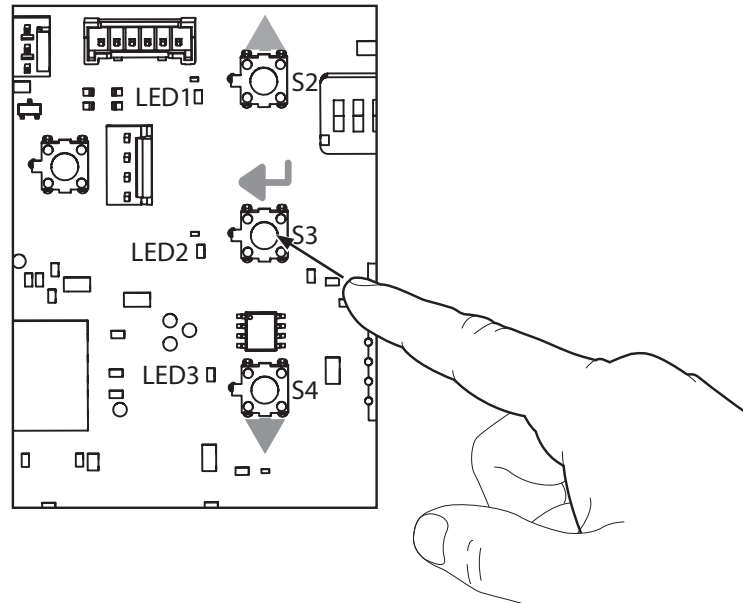

**NOTE:** If you hear three short beeps in succession, the programming mode has timed out and you will need to redo Steps 1-3.

To forget the FM130, simply follow steps 1 and 2 above to verify that it no longer activates the gate opener.

#### Learning an FM130 to an MM271, MM272 or HD272 Automatic Gate Opener

1. Use the On/Off switch on the control box to power the system down.
2. Take the battery out of the green FM130 transmitter and put it back in.
3. While the red light is blinking on the FM130 transmitter, power the system on with the On/Off switch on the control box
4. After the startup beep, there will be a long silence for about 10 seconds, followed by a continuous beep sound.
5. Test the FM130 by closing the gate and removing and replacing a battery in the green FM130 transmitter. If the gate opens, the FM130 has been properly programmed to your control board.
6. Proceed to page 7: "**Install Sensor and Transmitter Module**".

To forget the FM130, simply follow steps 1-5 above then test the sensor to verify that it no longer activates the gate opener.

**NOTE for MM271:** The gate must be in the closed position with the arm extended to delete the FM130. The gate can be in any position to learn it.

**IF THE PROCESS FAILS ON THE MM271, MM272 or HD272:** You must use a Mighty Mule transmitter with DIP switches (FM134, FM135, MM3BT, RB741, or RB742) to program the FM130. Simply match the DIP switch patterns between the transmitter and FM130 then learn the transmitter to the system.

Contact Tech Support at (800) 421-1587 for a complimentary Mighty Mule transmitter with DIP switches to program the FM130 if you do not have one.



# Instructions for Installing the Optional RB709U-NB Receiver



**CAUTION:** The “Learn” process may activate the gate. Please use caution when programming the Receiver.

\*RB709U-NB Receiver is only required for installations on MM360 systems and select legacy systems. Please call technical support for details.

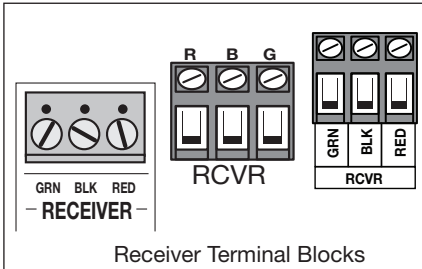

**Step 1:** The RB709U-NB will replace the gate opener receiver; disconnect the gate opener receiver’s RED, BLACK and GREEN wires from the receiver terminals on the gate opener control board.

**Step 2:** Mount the RB709U-NB Receiver.

- The Receiver can be mounted up to 10 ft. from the gate opener control board.
- DO NOT mount the Receiver upside down.
- DO NOT mount on a metal surface (will reduce range).
- Run Receiver cable through PVC conduit to protect it from damage.
- DO NOT run Receiver cable in conduit containing AC wiring.
- Receiver range can vary depending upon weather, topography and external interference.

**Step 3:** Connect the RED and BLACK wires from the Receiver to the power supply (see illustration, page 5).

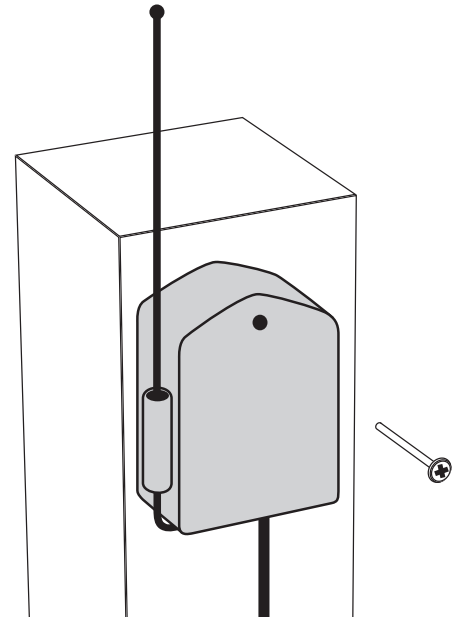

**CAUTION:** The “Learn” process may activate the gate. Please use caution when programming the Receiver.

**NOTE:** You will have to use a small screwdriver or a pen to depress the LEARN CH buttons on the receiver.

**Step 4:** Connect the Receiver’s Channel 1 wires (GREEN and BLUE) to your control board (see illustration, page 5). Press and hold the Entry Transmitter button then the Receiver’s LEARN CH 1 button at the same time. The indicator light on the Receiver should blink once within 1–2 seconds to indicate that the Entry Transmitter setting is now programmed into the Receiver.

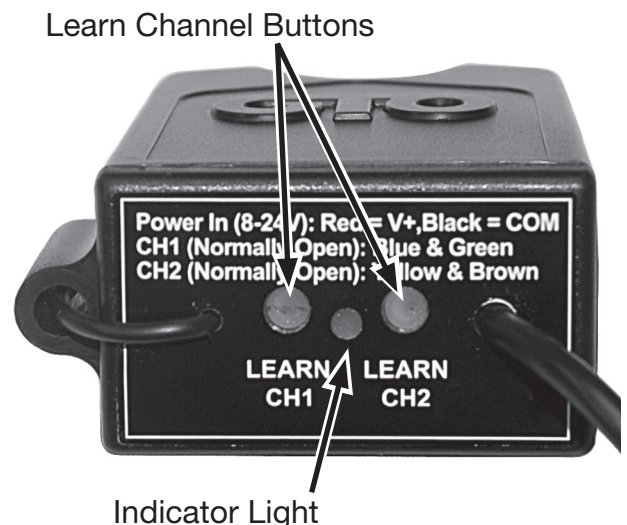



# Control Board Wiring

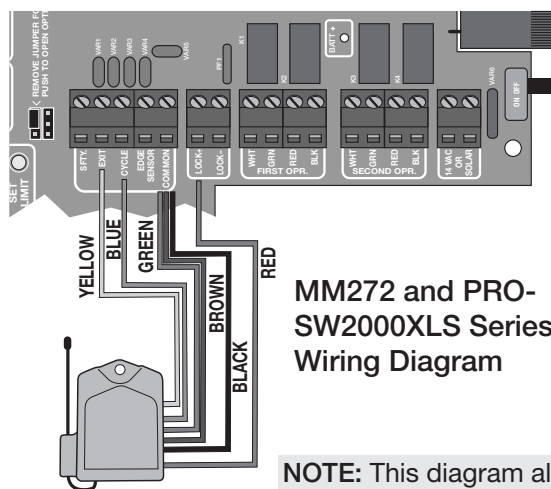
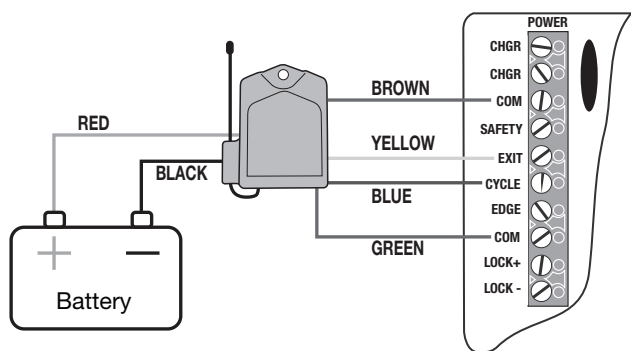
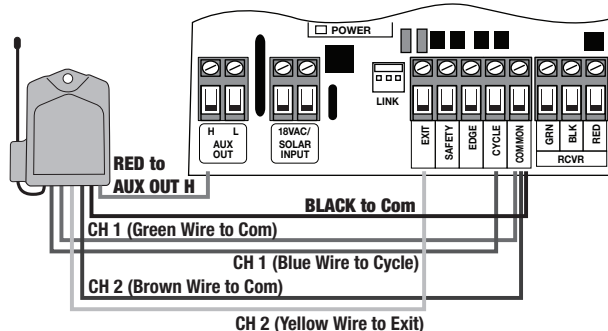
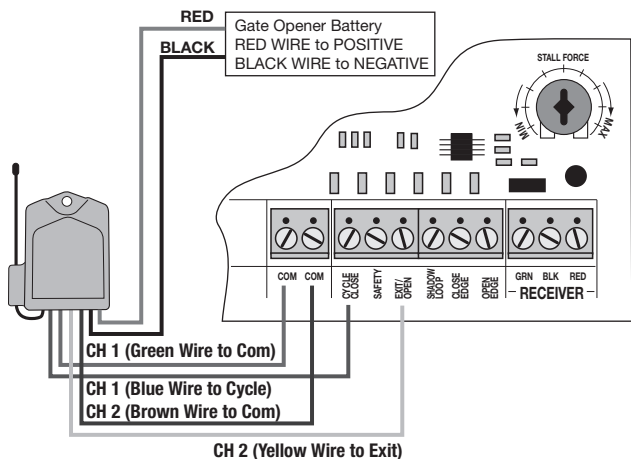

MM272 and PRO-SW2000XLS Series Wiring Diagram

NOTE: This diagram also works with MM260.

NOTE: This diagram also works for MM262, MM362 and MM462.

## MM271 Wiring Diagram

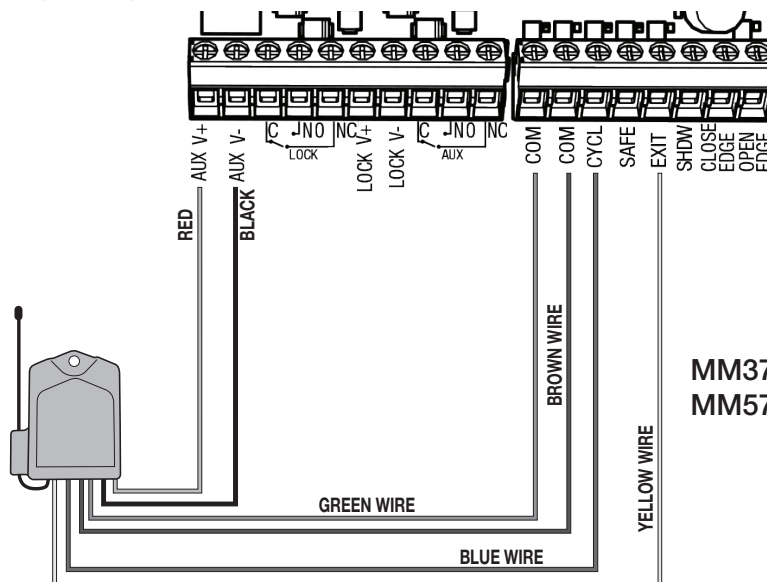

MM371W, MM372W, MM571W  
MM572W and TS571W Wiring Diagram

- Step 5:** Connect the Receiver's Channel 2 wires (YELLOW and BROWN) to your control board (see illustration above).
- Step 6:** Have a helper install the 2 "AA" batteries in the Transmitter Module: this will immediately start 30 seconds of transmission from the Wireless Vehicle Sensor. During the 30 second transmission, press and hold the Receiver's LEARN CH 2 button. The indicator light on the Receiver should blink twice within 1-2 seconds to indicate that the Wireless Vehicle Sensor setting is now programmed into the Receiver.
- Step 7:** Proceed to "Test the System".

## 5. Test the System

**Step 1:** Make sure gate opener is turned ON and gate is in the closed position.

**Step 2:** Remove and install 2 “AA” batteries (included) in the Transmitter Module; **the gate will open**. Wait 60 seconds before proceeding to the next step and **DO NOT move the sensor, any vehicles, or metal objects that are within 25 ft. during this calibration/“self-test” 60-second period**.

**Step 3:** Use your Entry Transmitter to close the gate. Test the Wireless Vehicle Sensor by driving your vehicle past the Sensor at normal driveway speed. The gate should open each time; if it does not, use a small screwdriver to increase the Sensitivity Adjustment potentiometer (clockwise rotation). See below.

**Step 4:** Once operation is satisfactory, turn the gate opener OFF. Fill the holes and trench with soil and tamp firm. The bottom third of the Mounting Post should be buried firmly in the ground.

**Step 5:** Turn the gate opener ON and make sure gate is in the closed position. Replace Transmitter Module cover and test the system again (Step 3).

**NOTE:** Do not cover the Transmitter Module with anything metal, as this will cause signal interference.

Your installation is now complete. If your Wireless Vehicle Sensor is not working properly, please refer to the **Troubleshooting Guide** on back cover.

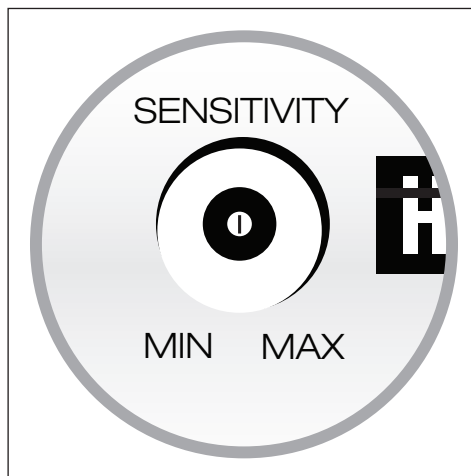

**Sensitivity Adjustment Potentiometer**

# Troubleshooting Guide

If your Wireless Vehicle Sensor is not operating properly, please follow this checklist:

**IMPORTANT:** If you make any of the following adjustments, you will need to recalibrate the Transmitter Module before retesting (see page 10, Test the System).

## A. IF THE GATE IS NOT OPENING:

1. Check the batteries:
  - a. Verify batteries are installed correctly (align the “+” signs on the battery and in the battery compartment).
  - b. Verify batteries are working. Remove and reinstall the batteries. The Transmit Indicator on the Transmitter Module should blink for 30 seconds. If not, try installing a new pair of “AA” batteries.

**NOTE:** When reinstalling batteries, the system will need to recalibrate (page 10, Test the System). Do not move any metal objects or the Transmitter Module for 60 seconds after reinstalling batteries.

2. Verify that the Sensor Cable is connected to the base of the Transmitter Module.
3. Increase the Sensitivity Adjustment on the Transmitter Module (page 10, **Test the System**, step 3).
4. Verify that you have properly placed the Transmitter Module. Be sure it is installed:
  - on the same side of the driveway as the gate opener/receiver.
  - within 100 ft. and “line of sight” of the gate opener/receiver.
  - 12 in. above ground level.
5. Verify that the Sensor is not more than 2 ft. from—and parallel to—the driveway edge.
6. If the Receiver was installed:
  - a. Repeat the “learn” process (page 8).
  - b. Verify that the Receiver is correctly wired to the gate opener control board (page 10)
7. If the Receiver was NOT installed:
  - a. Verify that the Transmitter Module DIP Switch settings were adjusted to match the Entry Transmitter’s DIP Switch settings (page 4).
  - b. Verify that the Entry Transmitter opens the gate. If not, you will need to program the Entry Transmitter’s settings into the gate opener receiver (see your gate opener Installation Manual), and then match the Transmitter Module’s DIP Switch settings with the Entry Transmitter.

(For MM371W, MM372W, MM571W, MM572W, TS571W, MM271, MM272 and HD272) Verify that the Receiver was paired correctly to the gate opener (page 7).

## B. IF THE GATE IS OPENING RANDOMLY:

1. Verify that the Sensor is at least 25 ft. from the roadway and/or neighbors’ driveways.
2. Verify that there are no moving metal objects within a 25 ft. radius of the Sensor. (**NOTE:** in areas with high winds, metal objects such as flag poles/swing sets can trigger the Sensor if they are within range.)
3. Do not put Sensor Cable in PVC conduit along with other AC or control wires.
4. Adjust the Sensitivity on the Transmitter Module (page 10, **Test the System**, step 3).
5. Recalibrate unit by removing and reinstalling the batteries. Allow 60 seconds for calibration (page 10, **Test the System**).

If you are unable to solve the problem, call the Technical Support Department at 1-800-421-1587.



**This product and any accessory you purchase should only be installed on a gate opener that meets the current UL325 safety standards. If you have a gate opener that is not listed to the current standard, please contact the Nice sales department for consultation on a gate opener that can meet your specific needs.**

## FCC Warning

Changes or modifications to this unit not expressly approved by the party responsible for compliance could void the user's authority to operate the equipment.

NOTE: This equipment has been tested and found to comply with the limits for a Class B digital device, pursuant to Part 15 of the FCC Rules. These limits are designed to provide reasonable protection against harmful interference in a residential installation. This equipment generates, uses and can radiate radio frequency energy and, if not installed and used in accordance with the instructions, may cause harmful interference to radio communications.

However, there is no guarantee that interference will not occur in particular installations. If this equipment does cause harmful interference to radio or television reception, which can be determined by turning the equipment off and on, the user is encouraged to try to correct the interference by one or more of the following measures: • Reorient or replace the receiver antenna. • Increase the separation between the equipment and the receiver. • Connect the equipment into an outlet on a circuit different from that to which the receiver is connected. • Consult the dealer or an experienced radio/TV technician for help.

## Limited Warranty

This product is warranted to the original consumer ("You") by Nice North America against defects in material and workmanship for a period of twelve (12) months from the date of purchase. This limited warranty only extends to you if the item was purchased directly from Nice North America or through an authorized sales partner. Nice North America will, at its option, either repair or replace any product that it confirms is defective and eligible for service under this warranty and will return the repaired or replaced product to you at Nice North America's cost. This warranty does not apply to damage to the product from negligence, abuse, abnormal usage, misuse, accidents, acts of god, normal wear and tear, failure to follow the manufacturer's instructions, or arising from improper installation, storage or maintenance. Some states do not allow the exclusion or limitation of incidental and consequential damages, so the above limitation or exclusion may not apply. This warranty gives you specific legal rights and you may also have other rights, which vary from state to state. In order to be protected by this warranty, a copy of the receipt or other valid proof of purchase must be provided with any product that is being repaired or replaced under this warranty. In order to initiate warranty service for your product, please contact Tech Services at (800) 421-1587 for a Return Authorization Number ("RA") and other important details.

Model	Warranty Length
Gate Accessories	12 months



**Mighty Mule Sales & Technical Service: 800-421-1587**

*For more information about the full line of Mighty Mule Automatic Gate Operators, Gate Openers and Access Controls visit*

**[www.mightymule.com](http://www.mightymule.com)**

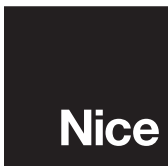

**Niceforyou.com**

©2023 Nice North America LLC.

Mighty Mule is a registered trademark of Nice North America LLC. All rights reserved.