

USER MANUAL
AOTU CUT PAPER DISPENSER

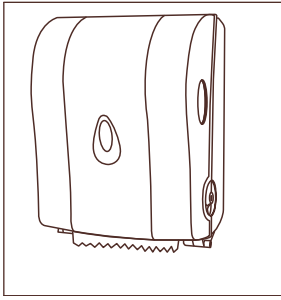

DPDR0020-B

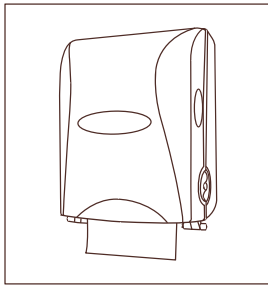

DPDR0020-B

Please read user manual carefull before using.

Installing paper instruction

Fig 3

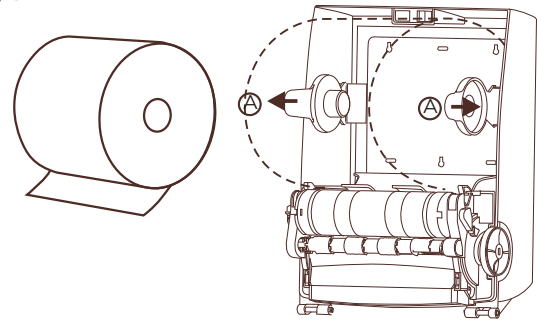

Ⓐ: Open the the buttons on both sides,put into the paper

Fig 4

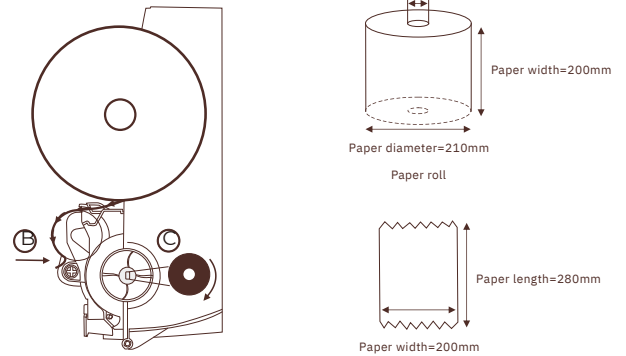

Ⓑ: Put the paper near the rotor

Ⓒ:Clockwise the button on the right, turn around the paper until it comes out.

Characteristic

- 1:Requires paper roll with max 210mm diameter and 35mm paper inner core for installation.
- 2:Two PC materials with transparent windows at both sides to check on paper usage.
- 3:There is a lock on this unit to keep the filling clean and prevent theft.
- 4:Paper pulled out smoothly.
- 5:Streamline outlook ,noble generous ,suitable for any enviroment.

Specifications

Product size	L300 ~ W237 ~ H410m
Core	m 36mm
Pulled out paper length	280mm
Pulled out paper width	200mm
Material	ABS

Operation icon

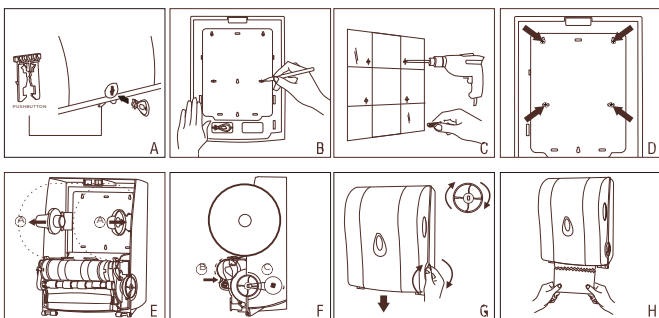

Installation steps

Step 1-as shown in Figure A,use the key together with the machine to open it .

Step 2-as shown in Figure B,Holding the bracket in place on the wall as a template, mark the drill holes with a pen.

Step 3-as shown in Figure C,Use a drill to drill 5.5mm holes on the wall. Insert wall plugs provided and install screws. Once done, mount bracket on the wall.(as shown in Figure D)

Step 4- as shown in Figure E, open the transparent paper rack , insert the paper.

Step 5- as shown in Figure F,the position the arrow pointed, put the paper close to shaft , rotate the button in the right until the paper come out, it is ready for using .

Step 6- as shown in G igure F,put the paper roll, clockwise the button.

Pull with both hands

Fig 1

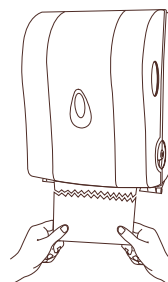
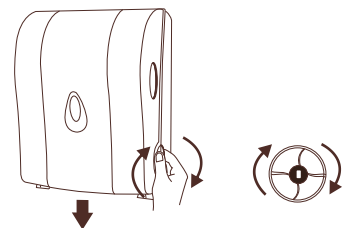

Fig 2



please clockwise the button on the right if no paper come out. see Fig 2