

DBCS0003

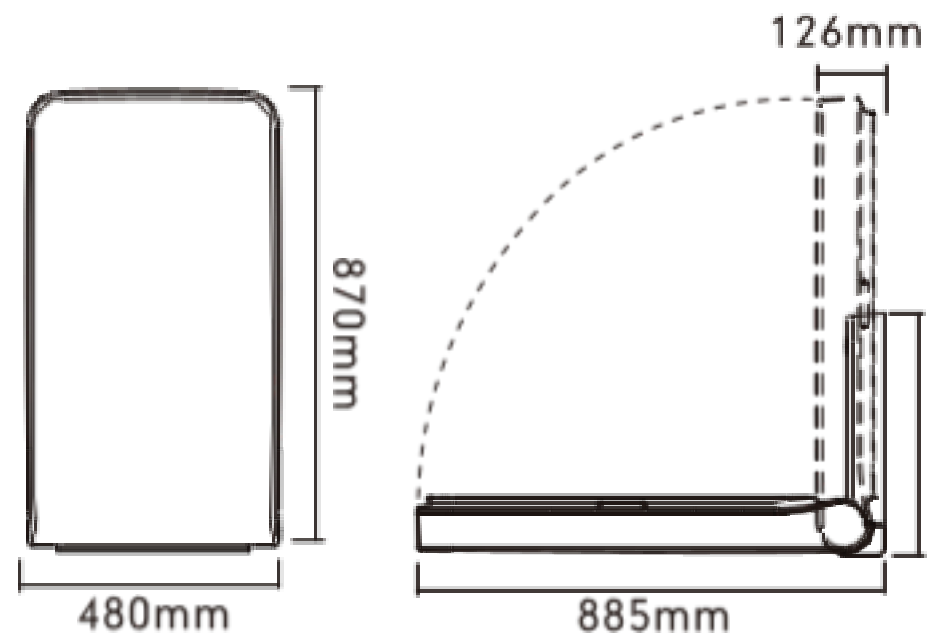

Specifications

Product Name:	Baby Change Station
Product Code:	DBCS0003
Material:	ABS
Color:	White
Shape:	Rectangular
Type:	Folded
Weight Capacity:	Less than 25 Kg
Recommended Installation:	800 mm at lowest point
Horizontal Baby Changing Station	
Hinge Bracket with metal design provides high strength and stability	
It is equip with Safety Belt to secure baby when changing diapers	

