

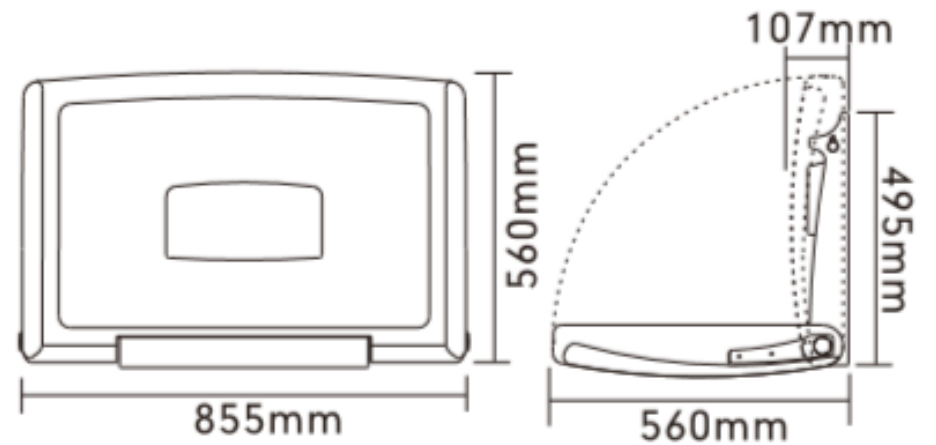

Dolphy Australia  
The sign of quality

**DBCS0001**

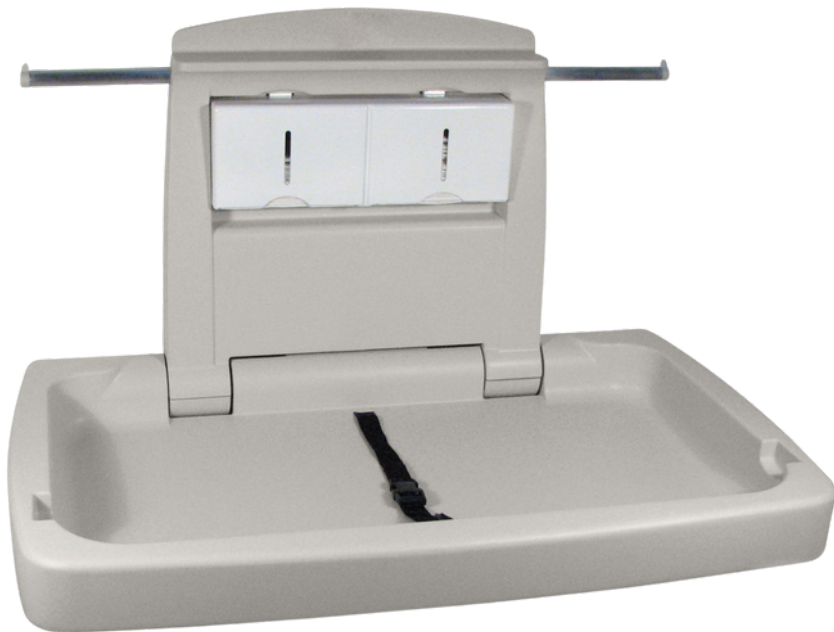

## Specifications

|                  |  |
|------------------|--|
| Product Name:    | Baby Change Station  |
| Product Code:    | DBCS0001   |
| Material:        | Durable and High-Quality HDPE (High Density polyethylene)        |
| Colour:          | White Granite  |
| Shape:           | Rectangular  |
| Type:            | Folded   |
| Weight Capacity: | Less than 25 Kg  |
| Features:        | Hinge bracket<br>Strong Suspension<br>Safety Belt to secure baby |

RECOMMENDED  
MOUNTING HEIGHT

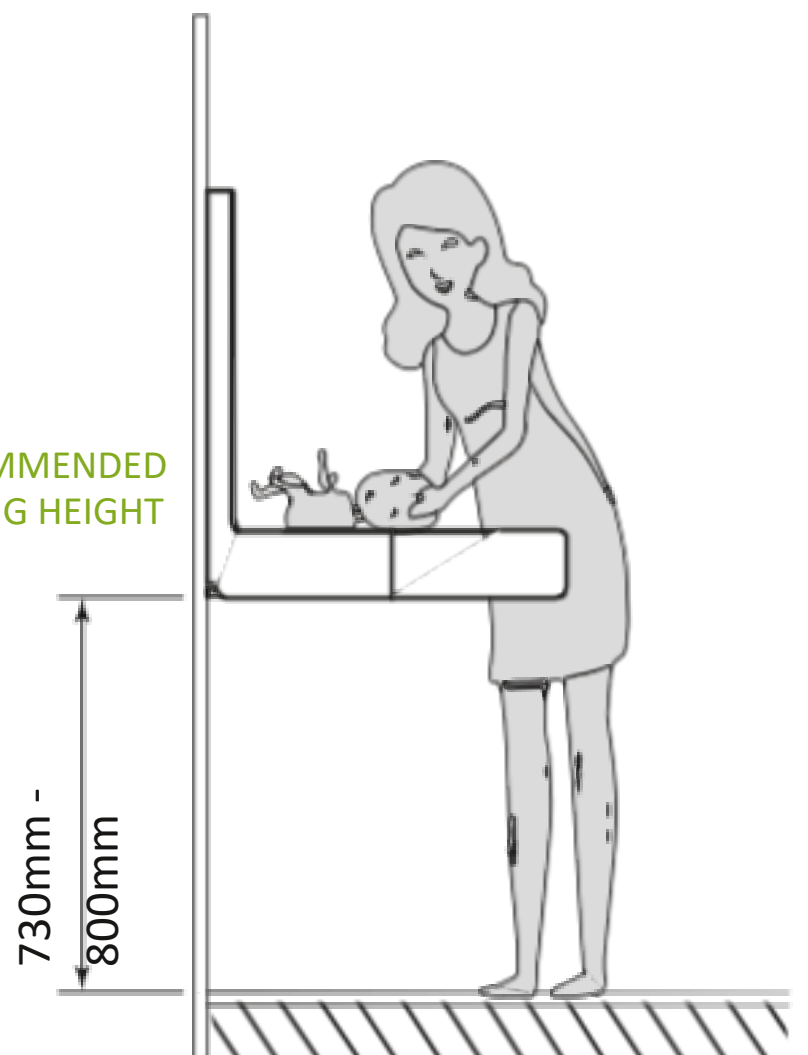

All dimensions are in mm