

## HOW TO USE THIS MANUAL

This service manual describes the service procedures for the VT600C/CD.

Follow the Maintenance Schedule (Section 3) recommendations to ensure that the vehicle is in peak operating condition and the emission levels are within the standards set by the U.S. Environmental Protection Agency and California Air Resources Board.

Performing the first scheduled maintenance is very important. It compensates for the initial wear that occurs during the break-in period.

Sections 1 and 3 apply to the whole motorcycle. Section 2 illustrates procedures for removal/installation of components that may be required to perform service described in the following sections. Sections 4 through 19 describe parts of the motorcycle, grouped according to location.

Find the section you want on this page, then turn to the table of contents on the first page of the section.

Most sections start with an assembly or system illustration, service information and troubleshooting for the section.

The subsequent pages give detailed procedures.

If you don't know the source of the trouble, go to section 21, Troubleshooting.

ALL INFORMATION, ILLUSTRATIONS, DIRECTIONS AND SPECIFICATIONS INCLUDED IN THIS PUBLICATION ARE BASED ON THE LATEST PRODUCT INFORMATION AVAILABLE AT THE TIME OF APPROVAL FOR PRINTING. HONDA MOTOR CO., LTD. RESERVES THE RIGHT TO MAKE CHANGES AT ANY TIME WITHOUT NOTICE AND WITHOUT INCURRING ANY OBLIGATION WHATEVER. NO PART OF THIS PUBLICATION MAY BE REPRODUCED WITHOUT WRITTEN PERMISSION. THIS MANUAL IS WRITTEN FOR PERSONS WHO HAVE ACQUIRED BASIC KNOWLEDGE OF MAINTENANCE ON HONDA MOTORCYCLES, MOTOR SCOOTERS OR ATVS.











HONDA MOTOR CO., LTD.  
SERVICE PUBLICATION OFFICE

## CONTENTS

	<b>GENERAL INFORMATION</b>	<b>1</b>
	<b>FRAME/BODY PANELS/EXHAUST SYSTEM</b>	<b>2</b>
	<b>MAINTENANCE</b>	<b>3</b>
<b>ENGINE AND DRIVE TRAIN</b>	<b>LUBRICATION SYSTEM</b>	<b>4</b>
	<b>FUEL SYSTEM</b>	<b>5</b>
	<b>COOLING SYSTEM</b>	<b>6</b>
	<b>ENGINE REMOVAL/INSTALLATION</b>	<b>7</b>
	<b>CLUTCH/GEARSHIFT LINKAGE</b>	<b>8</b>
	<b>ALTERNATOR/STARTER CLUTCH</b>	<b>9</b>
	<b>CYLINDER HEAD/VALVES</b>	<b>10</b>
	<b>CYLINDER/PISTON</b>	<b>11</b>
	<b>CRANKSHAFT/TRANSMISSION</b>	<b>12</b>
<b>CHASSIS</b>	<b>FRONT WHEEL/SUSPENSION/STEERING</b>	<b>13</b>
	<b>REAR WHEEL/BRAKE/SUSPENSION</b>	<b>14</b>
	<b>HYDRAULIC BRAKE</b>	<b>15</b>
<b>ELECTRICAL</b>	<b>BATTERY/CHARGING SYSTEM</b>	<b>16</b>
	<b>IGNITION SYSTEM</b>	<b>17</b>
	<b>ELECTRIC STARTER</b>	<b>18</b>
	<b>LIGHTS/METERS/SWITCHES</b>	<b>19</b>
	<b>WIRING DIAGRAM</b>	<b>20</b>
	<b>TROUBLESHOOTING</b>	<b>21</b>
	<b>INDEX</b>	<b>22</b>

# SYMBOLS

The symbols used throughout this manual show specific service procedures. If supplementary information is required pertaining to these symbols, it would be explained specifically in the text without the use of the symbols.

	Replace the part(s) with new one(s) before assembly.
	Use recommended engine oil, unless otherwise specified.
	Use molybdenum oil solution (mixture of the engine oil and molybdenum grease in a ratio of 1 : 1).
	Use multi-purpose grease (Lithium based multi-purpose grease NLGI # 2 or equivalent).
	Use molybdenum disulfide grease (containing more than 3 % molybdenum disulfide, NLGI # 2 or equivalent). Example: Molykote® BR-2 plus manufactured by Dow Corning, U. S. A. Multi-purpose M-2 manufactured by Mitsubishi Oil, Japan
	Use molybdenum disulfide paste (containing more than 40 % molybdenum disulfide, NLGI # 2 or equivalent). Example: Molykote® A-n paste, manufactured by Dow Corning, U. S. A. Honda Moly 60 (U. S. A. only) Rocol ASP manufactured by Rocol Limited, U. K. Rocol Paste manufactured by Sumico Lubricant, Japan
	Use silicone grease.
	Apply a locking agent. Use a middle strength locking agent unless otherwise specified.
	Apply sealant.
	Use DOT 4 brake fluid. Use the recommended brake fluid unless otherwise specified.
	Use Fork or Suspension Fluid.

NEW

# 1. GENERAL INFORMATION

1

GENERAL SAFETY	1-1	LUBRICATION & SEAL POINTS	1-19
SERVICE RULES	1-2	CABLE & HARNESS ROUTING	1-22
MODEL IDENTIFICATION	1-3	EMISSION CONTROL SYSTEMS	1-33
SPECIFICATIONS	1-5	EMISSION CONTROL INFORMATION LABELS	1-36
TORQUE VALUES	1-14		
TOOLS	1-17		

## GENERAL SAFETY

### CARBON MONOXIDE

If the engine must be running to do some work, make sure the area is well ventilated. Never run the engine in an enclosed area.

#### **▲WARNING**

*The exhaust contains poisonous carbon monoxide gas that can cause loss of consciousness and may lead to death.*

Run the engine in an open area or with an exhaust evacuation system in an enclosed area.

### GASOLINE

Work in a well ventilated area. Keep cigarettes, flames or sparks away from the work area or where gasoline is stored.

#### **▲WARNING**

*Gasoline is extremely flammable and is explosive under certain conditions. KEEP OUT OF REACH OF CHILDREN.*

### HOT COMPONENTS

#### **▲WARNING**

*Engine and exhaust system parts become very hot and remain hot for some time after the engine is run. Wear insulated gloves or wait until the engine and exhaust system have cooled before handling these parts.*

### USED ENGINE OIL

#### **▲WARNING**

*Used engine oil may cause skin cancer if repeatedly left in contact with the skin for prolonged periods. Although this is unlikely unless you handle used oil on a daily basis, it is still advisable to thoroughly wash your hands with soap and water as soon as possible after handling used oil. KEEP OUT OF REACH OF CHILDREN.*

### BRAKE FLUID

#### **CAUTION:**

*Spilling fluid on painted, plastic or rubber parts will damage them. Place a clean shop towel over these parts whenever the system is serviced. KEEP OUT OF REACH OF CHILDREN.*

## GENERAL INFORMATION

---

### COOLANT

Under some conditions, the ethylene glycol in engine coolant is combustible and its flame is not visible. If the ethylene glycol does ignite, you will not see any flame, but you can be burned.

#### **▲WARNING**

- *Avoid spilling engine coolant on the exhaust system or engine parts. They may be hot enough to cause the coolant to ignite and burn without a visible flame.*
  - *Coolant (ethylene glycol) can cause some skin irritation and is poisonous if swallowed. KEEP OUT OF REACH OF CHILDREN.*
  - *Keep out of reach of pets and some pets are attracted to the smell and taste of coolant and can die if they drink it.*
  - *Do not remove the radiator cap when the engine is hot. The coolant is under pressure and could scald you.*
- 

If coolant contacts your skin, wash the affected areas immediately with soap and water. If coolant contacts your eyes, flush them thoroughly with fresh water and get immediate medical attention. If swallowed, the victim must be forced to vomit then rinse mouth and throat with fresh water before obtaining medical attention. Because of these dangers, keep out of the reach of children. Recycle used coolant in an ecologically correct manner.

## SERVICE RULES

1. Use genuine HONDA or HONDA-recommended parts and lubricants or their equivalents. Parts that don't meet HONDA's design specifications may cause damage to the motorcycle.
2. Use the special tools designed for this product to avoid damage and incorrect assembly.
3. Use only metric tools when servicing the motorcycle. Metric bolts, nuts and screws are not interchangeable with English fasteners.
4. Install new gaskets, O-rings, cotter pins, and lock plates when reassembling.
5. When tightening bolts or nuts, begin with the larger diameter or inner bolt first. Then tighten to the specified torque diagonally in incremental steps unless a particular sequence is specified.
6. Clean parts in cleaning solvent upon disassembly. Lubricate any sliding surfaces before reassembly.
7. After reassembly, check all parts for proper installation and operation.
8. Route all cable and harness routing as shown on pages 1-21 through 1-29, Cable and Harness Routing.

### BATTERY HYDROGEN GAS & ELECTROLYTE

#### **▲WARNING**

- *The battery gives off explosive gases; keep sparks, flames and cigarettes away. Provide adequate ventilation when charging.*
  - *The battery contains sulfuric acid (electrolyte). Contact with skin or eyes may cause severe burns. Wear protective clothing and a face shield.*
    - *If electrolyte gets on your skin, flush with water.*
    - *If electrolyte gets in your eyes, flush with water for at least 15 minutes and call a physician immediately.*
  - *Electrolyte is poisonous.*
    - *If swallowed, drink large quantities of water or milk and follow with milk of magnesia or vegetable oil and call a physician. KEEP OUT OF REACH OF CHILDREN.*
-

## MODEL IDENTIFICATION

'97-'98:

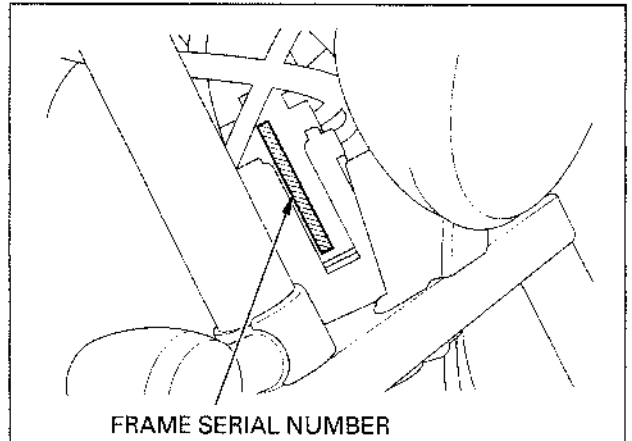
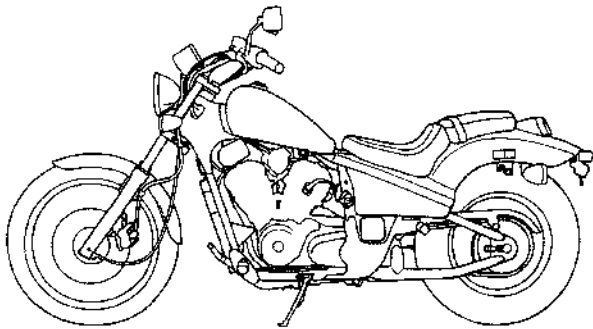

- (1) The frame serial number is stamped on the right side of the steering head.

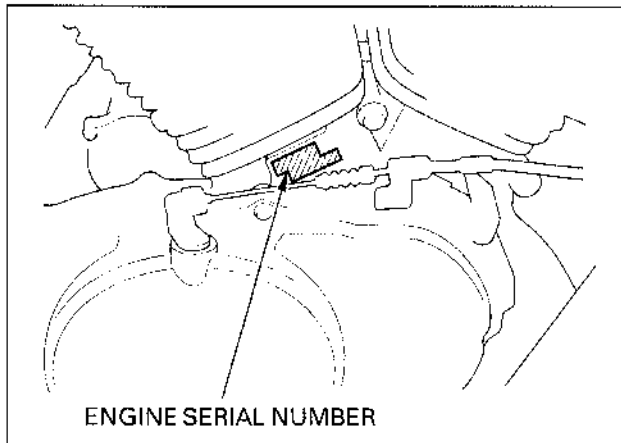

- (2) The engine serial number is stamped on the right side of the crankcase below the rear cylinder.

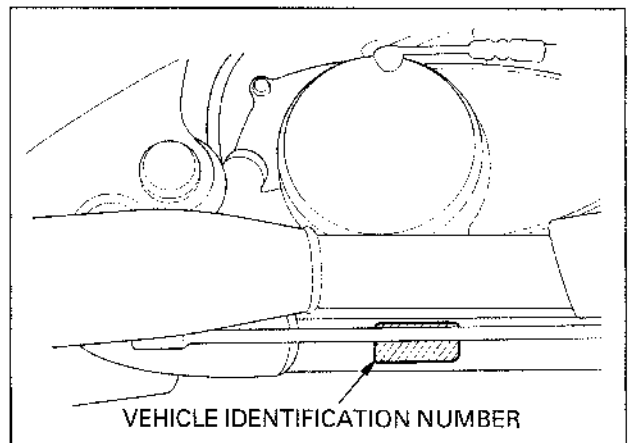

- (3) The Vehicle Identification Number (VIN) is located on the right side of the frame below the exhaust pipe.

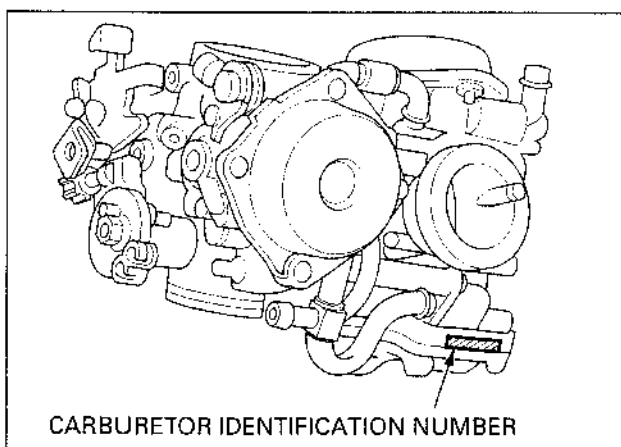

- (4) The carburetor identification numbers are stamped on the intake side of the carburetor body as shown.

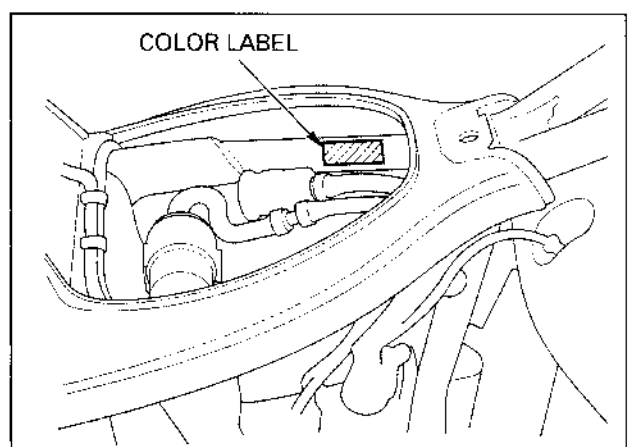

- (5) The color label is attached on the frame under the seat. When ordering color-coded parts, always specify the designated color code.

## GENERAL INFORMATION

### MODEL IDENTIFICATION

After '98:

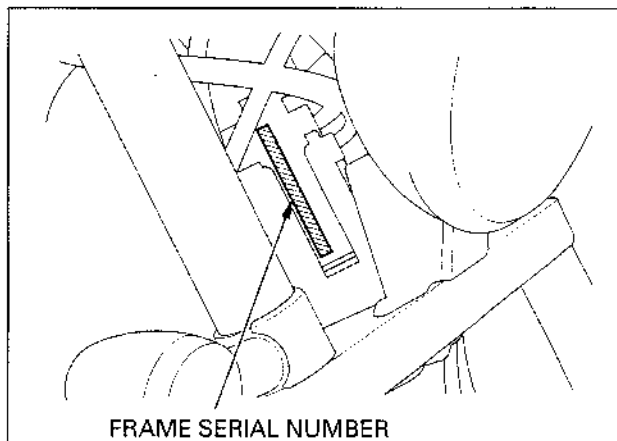
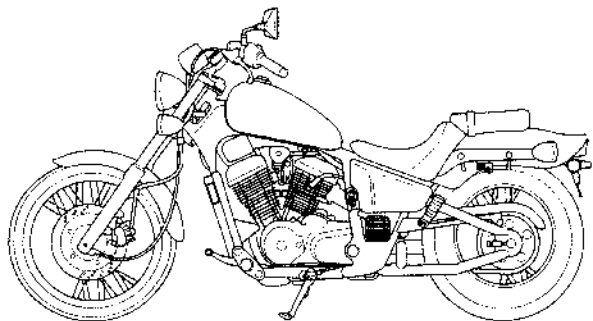

- (1) The frame serial number is stamped on the right side of the steering head.

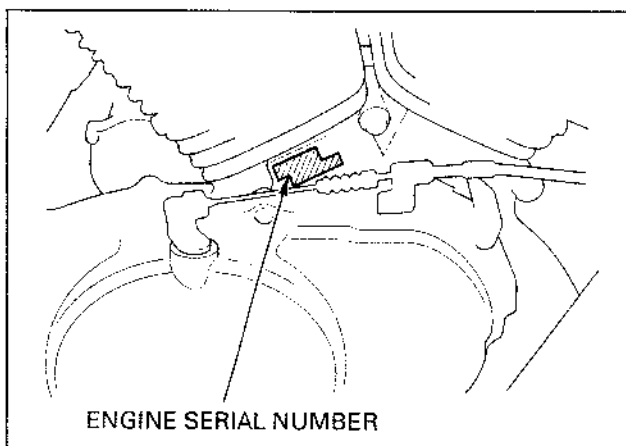

- (2) The engine serial number is stamped on the right side of the crankcase below the rear cylinder.

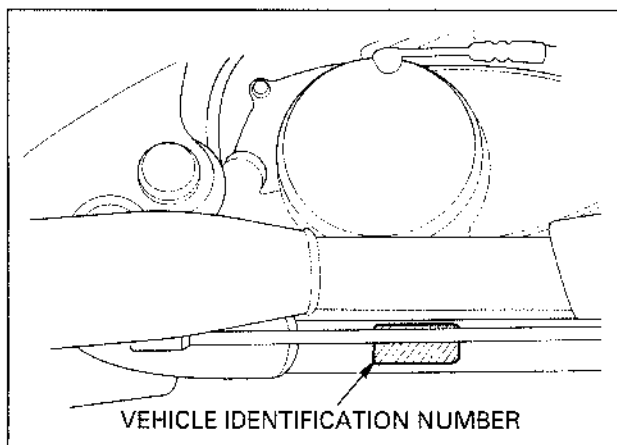

- (3) The Vehicle Identification Number (VIN) is located on the right side of the frame below the exhaust pipe.

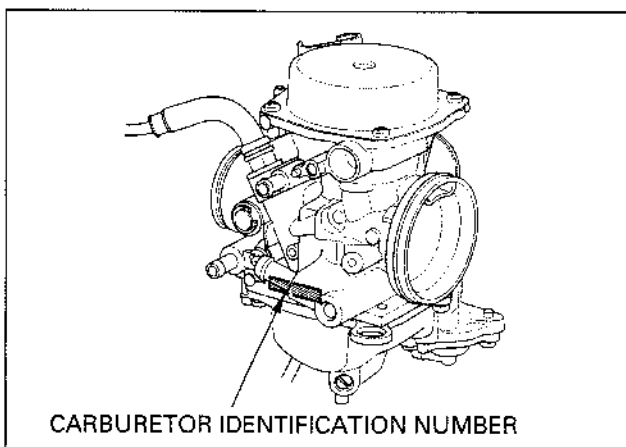

- (4) The carburetor identification numbers are stamped on the fuel tube joint side of the carburetor body as shown.

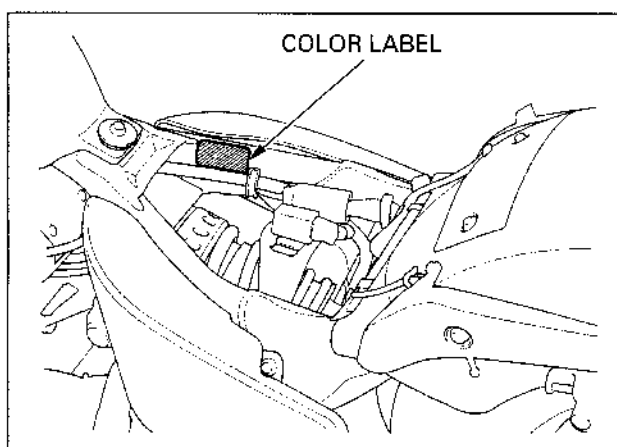

- (5) The color label is attached on the frame under the seat. When ordering color-coded parts, always specify the designated color code.

## SPECIFICATIONS

GENERAL		ITEM	SPECIFICATIONS	
DIMENSIONS	Overall length		2,310 mm (90.9 in)	
	Overall width	'97-'98:	890 mm (35.0 in)	
		After '98:	880 mm (34.6 in)	
	Overall height	'97-'98:	1,125 mm (44.3 in)	
		After '98:	1,120 mm (44.1 in)	
	Wheelbase	'97-'98:	1,605 mm (63.2 in)	
		After '98:	1,600 mm (63.0 in)	
	Seat height	'97-'98:	690 mm (27.2 in)	
		After '98:	650 mm (25.6 in)	
	Footpeg height	'97-'98:	285 mm (11.2 in)	
		After '98:	283 mm (11.1 in)	
	Ground clearance	'97-'98:	140 mm (5.5 in)	
		After '98:	135 mm (5.3 in)	
	Dry weight			
	VT600C			
	49 state/Canada type	'97-'98:	199 kg (439 lbs)	
	49 state/Canada type	After '98:	205 kg (452 lbs)	
	California type	'97-'98:	199 kg (439 lbs)	
	California type	After '98:	206 kg (454 lbs)	
	VT600CD			
	49 state/Canada type	'97-'98:	202 kg (445 lbs)	
	49 state/Canada type	After '98:	208 kg (459 lbs)	
	California type	'97-'98:	203 kg (448 lbs)	
	California type	After '98:	209 kg (461 lbs)	
	Curb weight			
	VT600C			
	49 state/Canada type	'97-'98:	213 kg (470 lbs)	
49 state/Canada type	After '98:	214 kg (472 lbs)		
California type	'97-'98:	214 kg (472 lbs)		
California type	After '98:	215 kg (474 lbs)		
VT600CD				
49 state/Canada type	'97-'98:	216 kg (476 lbs)		
49 state/Canada type	After '98:	217 kg (478 lbs)		
California type	'97-'98:	217 kg (478 lbs)		
California type	After '98:	218 kg (481 lbs)		
FRAME	Frame type		Double cradle	
	Front suspension		Telescopic fork	
	Front wheel travel		120 mm (4.7 in)	
	Rear suspension		Swingarm	
	Rear wheel travel		90 mm (3.5 in)	
	Front tire size		100/90-19 57S	
	Rear tire size		170/80-15 M/C 77S	
	Tire brand	Front	'97-'98:	BRIDGESTONE L309 / DUNLOP F24
			After '98:	DUNLOP F24
		Rear	'97-'98:	BRIDGESTONE G546 / DUNLOP K555
			After '98:	DUNLOP D404
	Front brake			Hydraulic single disc brake
	Rear brake			Internal expanding shoe
	Caster angle			35°
	Trail length	'97-'98:	164 mm (6.5 in)	
	After '98:	161 mm (6.3 in)		
Fuel tank capacity			11.0 ℓ (2.91 US gal , 2.42 Imp gal)	
Fuel tank reserve capacity			3.4 ℓ (0.90 US gal , 0.75 Imp gal)	

## GENERAL INFORMATION

GENERAL (Cont'd)			
	ITEM	SPECIFICATIONS	
ENGINE	Bore and stroke	75.0 × 66.0 mm (2.95 × 2.60 in)	
	Displacement	583 cm <sup>3</sup> (35.6 cu-in)	
	Compression ratio	9.2 : 1	
	Valve train	Silent, multi-link chain drive and OHC with rocker arm	
	Intake valve opens at 1 mm lift	'97-'98: 10° BTDC	
	Intake valve opens at 1 mm lift	After '98: 0° BTDC	
	Intake valve closes at 1 mm lift	'97-'98: 30° ABDC	
	Intake valve closes at 1 mm lift	After '98: 20° ABDC	
	Exhaust valve opens at 1 mm lift	'97-'98: 30° BBDC	
	Exhaust valve opens at 1 mm lift	After '98: 30° BBDC	
	Exhaust valve closes at 1 mm lift	'97-'98: 10° ATDC	
	Exhaust valve closes at 1 mm lift	After '98: 0° ATDC	
	Lubrication system	Forced pressure and wet sump	
	Oil pump type	Trochoid	
	Cooling system	Liquid cooled	
Air filtration	Paper filter		
Crankshaft type	Unit type, two main journals		
Engine dry weight			
	VT600C	'97: 61.0 kg (134.5 lbs)	
		After '98: 62.0 kg (136.7 lbs)	
	VT600CD	64.0 kg (141.1 lbs)	
	Firing order	Front—308°—Rear—412°—Front	
	Cylinder arrangement	Two cylinders, 52° V transverse	
	Cylinder number	Front: # 2, Rear: # 1	
CARBURETOR	Carburetor type	'97-'98: CV (Constant Velocity) dual carburetor with fuel pump	
		After '98: CV (Constant Velocity) single carburetor with accelerator pump	
	Throttle bore	34 mm (1.3 in)	
DRIVE TRAIN	Clutch system	Multi-plate, wet	
	Clutch operation system	Mechanical type	
	Transmission	Constant mesh, 4-speed	
	Primary reduction	1.888 (36/68)	
	Final reduction	2.750 (44/16)	
	Gear ratio	1st	2.571 (36/14)
		2nd	1.700 (34/20)
3rd		1.227 (27/22)	
4th		0.931 (27/29)	
	Gearshift pattern	Left foot operated return system, 1-N-2-3-4	
ELECTRICAL	Ignition system	Full transistor digital ignition	
	Starting system	Electric starter motor	
	Charging system	Triple phase output alternator	
	Regulator/rectifier	SCR shorted/triple phase, full wave rectification	
	Lighting system	Battery	



## GENERAL INFORMATION

Unit: mm (in)

LUBRICATION SYSTEM ITEM		STANDARD	SERVICE LIMIT
Engine oil capacity	At draining	2.1 ℓ (2.2 US qt, 1.8 Imp qt)	
	At disassembly	2.8 ℓ (3.0 US qt, 2.5 Imp qt)	
	At oil filter change	2.25 ℓ (2.38 US qt, 1.98 Imp qt)	
Recommended engine oil		HONDA GN4 or HP4 4-stroke oil or equivalent motor oil API service classification SF or SG Viscosity: SAE 10W-40	
Oil pressure at oil pressure switch		441 kPa (4.5 kgf/cm <sup>2</sup> , 64 psi) at 6,000 rpm (80 °C/176 °F)	
Oil pump rotor	Tip clearance	0.15 (0.006)	0.20 (0.008)
	Body clearance	0.15 - 0.22 (0.006 - 0.009)	0.35 (0.014)
	Side clearance	0.02 - 0.07 (0.001 - 0.003)	0.10 (0.004)

FUEL SYSTEM ITEM		SPECIFICATIONS	
		49 state/Canada type	California type
Carburetor identification number	'97-'98	VDFDA	VDFEA
	After '98	VE5AC	VE5AB
Main jet	'97-'98		# 115
	After '98		# 125
Slow jet	'97-'98		# 40
	After '98		# 45
Pilot screw	Initial/opening	See page 5-30	
	High altitude adjustment	See page 5-37	
Float level	'97-'98	7.0 mm (0.28 in)	
	After '98	18.5 mm (0.73 in)	
Base carburetor (for synchronization, '97-'98 models)		Rear cylinder (# 1)	
Idle speed		1,200 ± 100 rpm	
Throttle grip free play		2 - 6 mm (1/12 - 1/4 in)	
Fuel pump flow capacity ('97-'98 models)		Minimum 800 cm <sup>3</sup> (27.1 US oz, 28.2 Imp oz) per minute at 13 V	

COOLING SYSTEM ITEM		SPECIFICATIONS
Coolant capacity	Radiator and engine	1.6 ℓ (1.7 US qt, 1.4 Imp qt)
	Reserve tank	0.4 ℓ (0.4 US qt, 0.4 Imp qt)
Radiator cap relief pressure		88 - 127 kPa (0.9 - 1.3 kgf/cm <sup>2</sup> , 12.8 - 18 psi)
Thermostat	Begin to open	80 - 84 °C (176 - 183 °F)
	Fully open	95 °C (203 °F)
	Valve lift	8 mm (0.3 in) minimum
Standard coolant concentration		50 % mixture with soft water

## GENERAL INFORMATION

<b>CLUTCH SYSTEM</b>		Unit: mm (in)	
<b>ITEM</b>		<b>STANDARD</b>	<b>SERVICE LIMIT</b>
Clutch lever free play		10 – 20 (3/8 – 3/4)	-----
Clutch spring free length		43.2 (1.70)	41.6 (1.64)
Clutch disc thickness	A	2.92 – 3.08 (0.115 – 0.121)	2.6 (0.10)
	B	2.92 – 3.08 (0.115 – 0.121)	2.6 (0.10)
Clutch plate warpage		-----	0.30 (0.012)
Clutch outer guide	I.D.	21.991 – 22.016 (0.8658 – 0.8668)	22.09 (0.870)
	O.D.	31.959 – 31.975 (1.2582 – 1.2589)	31.98 (1.259)
Clutch outer I.D.		32.000 – 32.025 (1.2598 – 1.2608)	32.10 (1.264)
Oil pump drive sprocket I.D.		32.000 – 32.025 (1.2598 – 1.2608)	32.10 (1.264)
Mainshaft O.D. at clutch outer guide		21.967 – 21.980 (0.8648 – 0.8654)	21.92 (0.863)

<b>ALTERNATOR/STARTER CLUTCH</b>		Unit: mm (in)	
<b>ITEM</b>		<b>STANDARD</b>	<b>SERVICE LIMIT</b>
Starter driven gear	I.D.	37.000 – 37.025 (1.4567 – 1.4577)	37.10 (1.461)
	O.D.	57.749 – 57.768 (2.2736 – 2.2743)	57.73 (2.273)
Starter clutch outer I.D.		74.414 – 74.440 (2.9297 – 2.9307)	74.46 (2.931)

# GENERAL INFORMATION

Unit: mm (in)

CYLINDER HEAD/VALVES			STANDARD	SERVICE LIMIT	
ITEM					
Cylinder compression			1,324 ± 98 kPa (13.5 ± 1.0 kgf/cm <sup>2</sup> , 192 ± 14 psi) at 400 rpm	0.10 (0.004)	
Cylinder head warpage					
Valve, valve guide	Valve clearance	IN	0.15 (0.006)		
		EX	0.20 (0.008)		
	Valve stem O.D.	IN	5.475 - 5.490 (0.2156 - 0.2161)	5.45 (0.215)	
		EX	6.555 - 6.570 (0.2581 - 0.2587)	6.55 (0.258)	
	Valve guide I.D.	IN	5.500 - 5.512 (0.2165 - 0.2170)	5.56 (0.219)	
		EX	6.600 - 6.615 (0.2598 - 0.2604)	6.65 (0.262)	
	Stem-to-guide clearance	IN	0.010 - 0.037 (0.0004 - 0.0015)	0.10 (0.004)	
		EX	0.030 - 0.060 (0.0012 - 0.0024)	0.11 (0.004)	
	Valve guide projection above cylinder head	IN	19.4 - 19.6 (0.76 - 0.77)		
		EX	17.9 - 18.1 (0.70 - 0.71)		
Valve seat width	IN/EX	0.90 - 1.10 (0.035 - 0.043)	1.5 (0.06)		
Valve spring free length	Inner	IN	38.11 (1.500)	36.47 (1.436)	
		EX	38.81 (1.528)	37.51 (1.477)	
	Outer	IN	42.14 (1.659)	40.58 (1.598)	
		EX	42.83 (1.686)	41.25 (1.624)	
Camshaft	Cam lobe height	IN	'97 - '98	37.930 (1.4933)	37.73 (1.485)
			After '98	37.188 - 37.348 (1.4641 - 1.4704)	37.16 (1.463)
		EX	'97 - '98	37.950 (1.4941)	37.75 (1.486)
			After '98	37.605 - 37.765 (1.4805 - 1.4868)	37.58 (1.480)
	Journal O.D.		21.959 - 21.980 (0.8645 - 0.8654)	21.90 (0.862)	
	Runout		0.030 (0.0012)	0.05 (0.002)	
	Oil clearance		0.050 - 0.111 (0.0020 - 0.0044)	0.13 (0.005)	
	Identification marks		"F": Front, "R": Rear		
Rocker arm I.D.	IN/EX	12.000 - 12.018 (0.4724 - 0.4731)	12.05 (0.474)		
Rocker arm shaft O.D.	IN/EX	11.966 - 11.984 (0.4711 - 0.4718)	11.91 (0.469)		
Rocker arm-to-rocker arm shaft clearance		0.016 - 0.052 (0.0006 - 0.0020)	0.07 (0.003)		

## GENERAL INFORMATION

CYLINDER/PISTON			Unit: mm (in)		
ITEM		STANDARD	SERVICE LIMIT		
Cylinder	I.D.	75.000 – 75.015 (2.9528 – 2.9533)	75.10 (2.957)		
	Out of round	—————	0.06 (0.002)		
	Taper	—————	0.06 (0.002)		
	Warpage	—————	0.10 (0.004)		
Piston, piston rings	Piston mark direction		"IN" mark facing toward the intake side		
	Piston O.D.		74.965 – 74.990 (2.9514 – 2.9524)		
	Piston O.D. measurement point		10 mm (0.4 in) from bottom of skirt		
	Piston pin bore I.D.		18.002 – 18.008 (0.7087 – 0.7090)		
	Piston pin O.D.		17.994 – 18.000 (0.7084 – 0.7087)		
	Piston-to-piston pin clearance		0.002 – 0.014 (0.0001 – 0.0006)		
	Piston ring-to-ring groove clearance	Top	0.015 – 0.045 (0.0006 – 0.0018)	0.10 (0.004)	
		Second	0.015 – 0.045 (0.0006 – 0.0018)	0.10 (0.004)	
	Piston ring end gap	Top	0.10 – 0.30 (0.004 – 0.012)	0.5 (0.02)	
		Second	0.10 – 0.30 (0.004 – 0.012)	0.5 (0.02)	
Oil (side rail)		0.20 – 0.70 (0.008 – 0.028)	0.9 (0.04)		
Piston ring mark	Top/second	"N" mark			
Cylinder-to-piston clearance		0.010 – 0.050 (0.0004 – 0.0020)		0.10 (0.004)	
Connecting rod small end I.D.		18.016 – 18.034 (0.7093 – 0.7100)		18.07 (0.711)	
Connecting rod-to-piston pin clearance		0.016 – 0.040 (0.0006 – 0.0016)		0.06 (0.002)	

CRANKSHAFT/TRANSMISSION			Unit: mm (in)	
ITEM		STANDARD	SERVICE LIMIT	
Crankshaft	Side clearance		0.05 – 0.20 (0.002 – 0.008)	
	Runout		—————	
	Crank pin oil clearance		0.028 – 0.052 (0.0011 – 0.0020)	
	Main journal oil clearance		0.025 – 0.041 (0.0010 – 0.0016)	
Transmission	Gear I.D.	M2, M4, C3	28.000 – 28.021 (1.1024 – 1.1032)	
		C1	24.000 – 24.021 (0.9449 – 0.9457)	
	Bushing O.D.	M2, M4, C3	27.959 – 27.980 (1.1007 – 1.1016)	
		C1	23.959 – 23.980 (0.9433 – 0.9441)	
	Bushing I.D.	M2	25.000 – 25.021 (0.9843 – 0.9851)	
		C1	20.016 – 20.037 (0.7880 – 0.7889)	
	Gear-to-bushing clearance	M2, M4	0.020 – 0.062 (0.0008 – 0.0024)	
		C1, C3	0.020 – 0.062 (0.0008 – 0.0024)	
	Mainshaft O.D.	M2 bushing	24.959 – 24.980 (0.9826 – 0.9835)	
	Countershaft O.D.	C1 bushing	19.980 – 19.993 (0.7866 – 0.7871)	
Bushing-to-shaft clearance	M2	0.020 – 0.062 (0.0008 – 0.0024)		
	C1	0.023 – 0.057 (0.0009 – 0.0022)		
Shift fork, fork shaft	Fork	I.D.	13.000 – 13.018 (0.5118 – 0.5125)	
		Claw thickness	5.93 – 6.00 (0.233 – 0.236)	
	Fork shaft O.D.		12.966 – 12.984 (0.5105 – 0.5112)	
Shift drum O.D. (at the left side journal)		11.966 – 11.984 (0.4711 – 0.4718)		11.94 (0.470)

## GENERAL INFORMATION

Unit: mm (in)

FRONT WHEEL/SUSPENSION/STEERING ITEM		STANDARD	SERVICE LIMIT
Minimum tire tread depth			1.5 (0.06)
Cold tire pressure	Up to 90 kg (200 lb) load	200 kPa (2.00 kgf/cm <sup>2</sup> , 29 psi)	
	Up to maximum weight capacity	200 kPa (2.00 kgf/cm <sup>2</sup> , 29 psi)	
Axle runout			0.20 (0.008)
Wheel rim runout	Radial		2.0 (0.08)
	Axial		2.0 (0.08)
Wheel hub-to-rim distance		32.3 ± 0.8 (1.27 ± 0.03)	
Wheel balance weight		Max 70 g (2.5 oz)	
Fork	Spring free length	333.9 (13.15)	327.2 (12.88)
	Spring direction	Tightly wound coils should be at the top	
	Tube runout		0.20 (0.008)
	Recommended fork fluid	Pro-Honda Suspension Fluid SS-8	
	Fluid level	111 (4.4)	
	Fluid capacity	449 ± 0.25 cm <sup>3</sup> (15.2 ± 0.02 US oz, 15.8 ± 0.09 Imp oz)	
Steering head bearing preload		0.9 – 1.4 kgf (2.0 – 3.1 lbf)	

Unit: mm (in)

REAR WHEEL/BRAKE/SUSPENSION ITEM		STANDARD	SERVICE LIMIT
Minimum tire tread depth			2.0 (0.08)
Cold tire pressure	Up to 90 kg (200 lb) load	200 kPa (2.00 kgf/cm <sup>2</sup> , 29 psi)	
	Up to maximum weight capacity	250 kPa (2.50 kgf/cm <sup>2</sup> , 36 psi)	
Axle runout			0.20 (0.008)
Wheel rim runout	Radial		2.0 (0.08)
	Axial		2.0 (0.08)
Wheel hub-to-rim distance		32.3 ± 0.8 (1.27 ± 0.03)	
Wheel balance weight		Max 70 g (2.5 oz)	
Drive chain link		120L	
Drive chain slack		20 – 30 (3/4 – 1-1/4)	50 (2.0)
Drive chain size	DID	525 V8	
	RK	525 SM5	
Rear brake	Drum I.D.	160.0 – 160.3 (6.30 – 6.31)	161 (6.3)
	Lining thickness	5 (0.2)	2 (0.1)
Brake pedal free play		20 – 30 (3/4 – 1-1/4)	
Shock absorber spring preload adjuster setting		2nd position	

NEW

## GENERAL INFORMATION

Unit: mm (in)

HYDRAULIC BRAKE ITEM	STANDARD	SERVICE LIMIT
Specified brake fluid	DOT 4	-----
Brake pad wear indicator	-----	To groove
Brake disc thickness	5.0 (0.20)	4.0 (0.16)
Brake disc runout	-----	0.30 (0.012)
Master cylinder I.D.	11.000 – 11.043 (0.4331 – 0.4348)	11.05 (0.435)
Master piston O.D.	10.957 – 10.984 (0.4314 – 0.4324)	10.945 (0.4309)
Caliper cylinder I.D.	27.000 – 27.050 (1.0630 – 1.0650)	27.06 (1.065)
Caliper piston O.D.	26.935 – 26.968 (1.0604 – 1.0617)	26.93 (1.060)

BATTERY/CHARGING SYSTEM ITEM		SPECIFICATIONS		
Battery	Capacity	12V-8 AH		
	Current leakage	1.3 mA max.		
	Voltage (20 °C/68 °F)	Fully charged	13.0 – 13.2 V	
		Needs charging	Below 12.3 V	
Charging current	Normal	0.8 A/10 h		
	Quick	4.0 A/1 h max		
Alternator	Capacity	345 W/5,000 rpm		
	Charging coil resistance (20 °C/68 °F)	0.1 – 1.0 Ω		
Regulator/rectifier regulated voltage		14 – 15 V/4,000 rpm		

IGNITION SYSTEM ITEM		SPECIFICATIONS	
Spark plug	Standard	DPR8EA-9 (NGK)	X24EPR-U9 (DENSO)
	For cold climate (below 5 °C/41 °F)	DPR7EA-9 (NGK)	X22EPR-U9 (DENSO)
	For extended high speed riding	DPR9EA-9 (NGK)	X27EPR-U9 (DENSO)
Spark plug gap		0.80 – 0.90 mm (0.031 – 0.035 in)	
Ignition coil primary peak voltage		100 V minimum	
Ignition pulse generator peak voltage		0.7 V minimum	
Ignition timing "F" mark		6.5° BTDC at idle	
Advance	Start	'97 – '98	2,000 ± 200 rpm
		After '98	1,800 ± 200 rpm
	Stop	6,000 ± 200 rpm	
Full advance		BTDC 30°	

## GENERAL INFORMATION

Unit: mm (in)

ELECTRIC STARTER ITEM	STANDARD	SERVICE LIMIT
Starter motor brush length	12.5 (0.49)	6.5 (0.26)

LIGHTS/METERS/SWITCHES ITEM		SPECIFICATIONS
Bulbs	Headlight (High/low beam)	12V-60/55W
	Brake/tail light	12V-32/3CP × 2
	Front turn signal/running light	12V-21/5W × 2
	Rear turn signal light	12V-21W × 2
	License light	12V-4CP
	Instrument light	12V-3.4W
	Turn signal indicator	12V-1.7W
	High beam indicator	12V-1.7W
	Neutral indicator	12V-1.7W
Fuse	Main fuse	30A
	Sub fuse	10A × 3, 15A × 1
Fuel pump flow capacity (min./minute) ('97 - '98 models)		800 cm <sup>3</sup> (27.1 US oz, 28.2 Imp oz)
Fan motor switch	Start to close (ON)	98 - 102°C (208 - 216°F)
	Start to open (OFF)	93 - 97°C (199 - 207°F)
Thermosensor resistance ('97 - '00)	50 °C/122 °F	130 - 180 Ω
	80 °C/176 °F	45 - 60 Ω
	120 °C/248 °F	10 - 20 Ω
Thermo switch (After '00)	Start to close (ON)	112 - 118°C (259 - 270°F)
	Start to open (OFF)	Below 108°C (252°F)

NEW

## GENERAL INFORMATION

### TORQUE VALUES

FASTENER TYPE	TORQUE N-m (kgf-m, lbf-ft)	FASTENER TYPE	TORQUE N-m (kgf-m, lbf-ft)
5 mm hex bolt and nut	5 (0.5, 3.6)	5 mm screw	4 (0.4, 2.9)
6 mm hex bolt and nut	10 (1.0, 7)	6 mm screw	9 (0.9, 6.5)
8 mm hex bolt and nut	22 (2.2, 16)	6 mm flange bolt (8 mm head)	9 (0.9, 6.5)
10 mm hex bolt and nut	35 (3.5, 25)	6 mm flange bolt (10 mm head)	12 (1.2, 9)
12 mm hex bolt and nut	54 (5.5, 40)	and nut	
		8 mm flange bolt and nut	26 (2.7, 20)
		10 mm flange bolt and nut	39 (4.0, 29)

- Torque specifications listed below are for important fasteners.
- Others should be tightened to standard torque values listed above.

- NOTES:
1. Apply sealant to the threads.
  2. Apply a locking agent to the threads.
  3. Apply molybdenum disulfide oil to the threads and flange surface.
  4. Apply grease to the threads.
  5. Stake.
  6. Apply oil to the threads and flange surface.
  7. Apply clean engine oil to the O-ring.
  8. U-nut.
  9. ALOC bolt: replace with a new one.

ENGINE	ITEM	Q'TY	THREAD DIA. (mm)	TORQUE N-m (kgf-m, lbf-ft)	REMARKS
<b>MAINTENANCE:</b>					
	Spark plug	4	12	14 (1.4, 10)	
	Crankshaft hole cap	1	30	15 (1.5, 11)	NOTE 3
	Timing hole cap	1	22	15 (1.5, 11)	NOTE 3
	Valve adjust cover	8	6	12 (1.2, 9)	
	Valve adjusting screw lock nut	6	7	23 (2.3, 17)	NOTE 6
	Drain bolt	'97 - '98: 1	14	34 (3.5, 25)	
		After '98:		30 (3.1, 22)	
	Oil filter cartridge	1	20	10 (1.0, 7)	NOTE 2
	Vacuum plug ('97 - '98)	2	5	3 (0.33, 2.4)	
<b>LUBRICATION SYSTEM:</b>					
	Oil pressure switch	'97 - '98: 1	PT1/8	10 (1.0, 7)	NOTE 1
		After '98:		12 (1.2, 9)	
	Oil pressure switch cord	1	4	2 (0.23, 1.7)	
	Oil pump driven sprocket bolt	1	6	15 (1.5, 11)	NOTE 2
	Oil pump cover bolt (After '98)	3	6	13 (1.3, 9)	
<b>ENGINE MOUNTING:</b>					
	Drive sprocket plate bolt	2	10	10 (1.0, 7)	
<b>CLUTCH/GEARSHIFT LINKAGE:</b>					
	Right crankcase cover bolt	13	6	12 (1.2, 9)	
	Clutch cable holder bolt	1	6	12 (1.2, 9)	
	Clutch lifter plate bolt	4	6	12 (1.2, 9)	
	Clutch center lock nut	'97 - '98: 1	18	127 (13.0, 94)	NOTE 5
		After '98:		128 (13.1, 95)	
	Primary drive gear bolt	1	12	88 (9.0, 65)	NOTE 6
	Gearshift cam plate bolt	1	8	12 (1.2, 9)	NOTE 2
	Left rear cover bolt	1	6	12 (1.2, 9)	
	Gearshift return spring pin	1	8	23 (2.3, 17)	



**GENERAL INFORMATION**

<b>ENGINE (Cont'd)</b>				
ITEM	Q'TY	THREAD DIA. (mm)	TORQUE N·m (kgf·m, lbf·ft)	REMARKS
<b>ALTERNATOR/STARTER CLUTCH:</b>				
Left crankcase cover bolt	10	6	12 (1.2, 9)	
Flywheel bolt	1	12	127 (13.0, 94)	NOTE 6
			128 (13.1, 95)	
Stator mounting socket bolt	4	6	12 (1.2, 9)	NOTE 2
Starter one-way clutch socket bolt	6	8	29 (3.0, 22)	NOTE 2
			30 (3.1, 22)	
Alternator cord clammer	2	6	12 (1.2, 9)	NOTE 2
Ignition pulse generator bolt	4	6	12 (1.2, 9)	NOTE 2
<b>CYLINDER HEAD:</b>				
Cylinder head cover bolt	4	6	10 (1.0, 7)	
Cam sprocket bolt	4	7	23 (2.3, 17)	NOTE 2
Camshaft holder 8 mm bolt	6	8	23 (2.3, 17)	
8 mm nut	4	8	23 (2.3, 17)	
Camshaft end holder bolt	4	6	9 (0.9, 6.5)	
			10 (1.0, 7)	
Cam chain tensioner mounting bolt	4	6	10 (1.0, 7)	NOTE 2
Cylinder head 8 mm bolt	4	8	23 (2.3, 17)	NOTE 6
6 mm bolt	2	6	12 (1.2, 9)	NOTE 6
10 mm nut	8	10	47 (4.8, 35)	NOTE 6
<b>CRANKSHAFT/TRANSMISSION:</b>				
Mainshaft bearing set plate bolt ('97 - '98)	1	6	12 (1.2, 9)	NOTE 2
Countershaft bearing set plate bolt ('97 - '98)	3	6	9 (0.9, 6.5)	NOTE 2
Bearing set plate bolt (After '98)	4	6	12 (1.2, 9)	NOTE 2
Cam chain tensioner set plate bolt	2	6	12 (1.2, 9)	NOTE 2
Crankcase 8 mm bolt	13	8	23 (2.3, 17)	
6 mm bolt	7	6	9 (0.9, 6.5)	
			12 (1.2, 9)	
Connecting rod bearing nut	4	8	33 (3.4, 25)	NOTE 6
Neutral switch	1	10	12 (1.2, 9)	NOTE 1
<b>ELECTRIC STARTER:</b>				
Starter motor cable nut	1	6	10 (1.0, 7)	

<b>FRAME</b>				
ITEM	Q'TY	THREAD DIA. (mm)	TORQUE N·m (kgf·m, lbf·ft)	REMARKS
<b>FRAME/BODY PANELS/EXHAUST SYSTEM:</b>				
Exhaust pipe joint nut	4	8	25 (2.5, 18)	
Exhaust cover bolt	3	6	12 (1.2, 9)	
Muffler bracket mounting bolt	1	8	20 (2.0, 14)	
nut	4	8	20 (2.0, 14)	
Sub-frame mounting bolt	2	6	12 (1.2, 9)	
nut	2	6	12 (1.2, 9)	
<b>MAINTENANCE:</b>				
Side stand pivot bolt	1	10	10 (1.0, 7)	
nut	1	10	29 (3.0, 22)	
			30 (3.1, 22)	
<b>FUEL SYSTEM:</b>				
Air cleaner housing cover bolt	1	6	10 (1.0, 7)	
Air cleaner housing mounting bolt	2	6	12 (1.2, 9)	
Fuel valve nut	1	22	23 (2.3, 17)	
			35 (3.6, 26)	
Fuel valve lever screw	1	5	4 (0.4, 2.9)	
Fuel tank mounting bolt	1	8	19 (1.9, 14)	
Throttle link cover screw	1	4	2 (0.21, 1.5)	

# GENERAL INFORMATION

FRAME (Cont'd)				
ITEM	Q'TY	THREAD DIA. (mm)	TORQUE N-m (kgf-m, lbf-ft)	REMARKS
<b>COOLING SYSTEM:</b>				
Radiator mounting bolt	1	6	9 (0.9, 6.5)	
Radiator grille mounting screw	1	6	9 (0.9, 6.5)	
Thermostat bracket bolt	1	6	10 (1.0, 7)	
Thermostat housing cover bolt	2	6	10 (1.0, 7)	
Thermosensor	'97-'00: 1	PT 1/8	10 (1.0, 7)	NOTE 1
Thermo switch <b>NEW</b>	After '00: 1	PT 1/8	8 (0.8, 5.8)	NOTE 1
Water hose band screw	4	-----	7 (0.7, 5.1)	
Fan motor switch	1	16	18 (1.8, 13)	NOTE 1
<b>ENGINE MOUNTING:</b>				
Front engine mounting bolt (upper)	'97-'98: 1	10	54 (5.5, 40)	
	After '98: 1		55 (5.6, 41)	
(lower)	'97-'98: 1	10	54 (5.5, 40)	
	After '98: 1		55 (5.6, 41)	
Rear engine mounting bolt	'97-'98: 1	10	54 (5.5, 40)	
	After '98: 1		55 (5.6, 41)	
Engine bracket bolt (front)	'97-'98: 4	8	26 (2.7, 20)	
	After '98: 4		27 (2.8, 20)	
(rear)	'97-'98: 2	8	26 (2.7, 20)	
	After '98: 2		27 (2.8, 20)	
Gearshift pedal pinch bolt	1	6	12 (1.2, 9)	
Footpeg bracket bolt	4	10	39 (4.0, 29)	
<b>FRONT WHEEL/SUSPENSION/STEERING:</b>				
Steering stem nut	1	24	103 (10.5, 76)	See page 13-40
Top thread A	1	26	-----	
Top thread B	1	26	-----	
Fork top bridge pinch bolt	2	7	11 (1.1, 8)	
Fork bottom bridge pinch bolt	2	10	49 (5.0, 36)	
Handlebar upper holder	4	8	29 (3.0, 22)	
Handlebar lower holder	2	8	23 (2.3, 17)	
Handlebar switch screw	4	5	4 (0.4, 2.9)	
Front axle	1	18	74 (7.5, 54)	
Front axle pinch bolt	2	7	22 (2.2, 16)	
Front brake disc mounting bolt	'97-'98: 5	8	39 (4.0, 29)	NOTE 9
	After '98: 5		42 (4.3, 31)	
Fork cap	2	34	23 (2.3, 17)	
Fork socket bolt	2	10	29 (3.0, 22)	NOTE 2
Spoke	56	4	4 (0.4, 2.9)	
<b>REAR WHEEL/BRAKE/SUSPENSION:</b>				
Rear axle nut	1	16	88 (9.0, 65)	NOTE 8
Driven sprocket nut	5	10	64 (6.5, 47)	NOTE 8
Rear shock absorber mounting nut (upper)	1	10	44 (4.5, 33)	
(lower)	1	10	44 (4.5, 33)	
Swingarm pivot nut	1	14	88 (9.0, 65)	
Rear brake stopper arm bolt	'97-'98: 2	8	22 (2.2, 16)	
	After '98: 2		21 (2.1, 15)	
Rear brake arm pinch bolt	'97-'98: 2	8	26 (2.7, 20)	
	After '98: 2		21 (2.1, 15)	
Rear brake middle rod joint bolt	2	6	9 (0.9, 6.5)	
Spoke	52	4	4 (0.4, 2.9)	

**GENERAL INFORMATION**

**FRAME (Cont'd)**

ITEM	Q'TY	THREAD DIA. (mm)	TORQUE N-m (kgf-m, lbf-ft)	REMARKS
<b>HYDRAULIC BRAKE:</b>				
Brake caliper mounting bolt	2	8	30 (3.1, 22)	NOTE 9
Caliper pin bolt	1	8	23 (2.3, 17)	
Bracket pin bolt	1	8	13 (1.3, 9)	
Pad pin	1	10	18 (1.8, 13)	
Pad pin plug	1	10	2 (0.25, 1.8)	
Brake caliper bleeder	1	8	6 (0.65, 4.7)	
Brake lever pivot bolt	1	6	1 (0.1, 0.7)	
Brake lever pivot nut	1	6	6 (0.6, 4.3)	
Master cylinder holder bolt	2	6	12 (1.2, 9)	
Master cylinder cover screw	2	4	1 (0.15, 1.1)	
Front brake light switch screw	1	4	1 (0.12, 0.9)	
Brake hose oil bolt	2	10	34 (3.5, 25)	
<b>LIGHTS/METERS/SWITCHES:</b>				
Side stand switch mounting bolt	1	6	9 (0.9, 6.5)	NOTE 9
<b>OTHER FASTENERS:</b>				
Fuel pump stay mounting nut ('97-'98) / Turn signal relay stay mounting nut (After '98)	1	6	9 (0.9, 6.5)	

**TOOLS**

- NOTES: 1. Equivalent commercially available in U.S.A.  
 2. Not available in U.S.A.  
 3. Alternative tool.  
 4. Newly provided tool.

DESCRIPTION	TOOL NUMBER	REMARKS	REF. SEC.
Carburetor float level gauge	07401-0010000		5
Pilot screw wrench	07LMA-MT8010A with 07PMA-MZ2011A		
Vacuum gauge	07404-0030000	NOTE 3: 07LMJ-001000A	4
Oil pressure gauge	07506-3000000	NOTE 1	4
Oil pressure gauge attachment	07510-4220100	NOTE 1	4
Lock nut wrench 17 × 27 mm	07716-0020300	NOTE 1	8
Gear holder	07724-0010100		8
Rotor puller	07733-0020001	NOTE 3: 07933-3290001	9
Valve guide driver, 5.5 mm	07742-0010100		10
Valve guide driver, 6.6 mm	07742-0010200	NOTE 2: 07942-6570100	10
Attachment, 32 × 35 mm	07746-0010100		14
Attachment, 42 × 47 mm	07746-0010300		12, 13, 14
Attachment, 52 × 55 mm	07746-0010400		12, 13
Pilot, 15 mm	07746-0040300		14
Pilot, 17 mm	07746-0040400		14
Pilot, 20 mm	07746-0040500		12, 13
Pilot, 22 mm	07746-0041000		12, 14
Pilot, 25 mm	07746-0040600		12
Bearing remover shaft	07746-0050100		13, 14
Bearing remover head, 17 mm	07746-0050500		14
Bearing remover head, 20 mm	07746-0050600		13
Attachment, 28 × 30 mm	07946-1870100		14
Driver	07749-0010000		12, 13, 14
Main bearing driver attachment	07HMF-MM90400		12
Valve spring compressor	07757-0010000	NOTE 3: 07957-3290001	10

## GENERAL INFORMATION

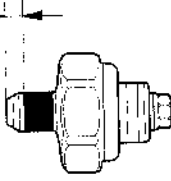
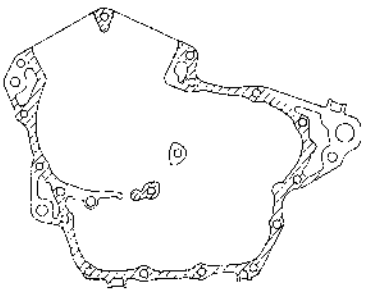

DESCRIPTION	TOOL NUMBER	REMARKS	REF. SEC.
Valve seat cutter		NOTE 1	10
Seat cutter, 27.5 mm (45° IN)	07780-0010200		
Seat cutter, 35 mm (45° EX)	07780-0010400		
Flat cutter, 28 mm (32° IN)	07780-0012100		
Flat cutter, 35 mm (32° EX)	07780-0012300		
Interior cutter, 30 mm (60° IN)	07780-0014000		
Interior cutter, 37.5 mm (60° EX)	07780-0014100		
Cutter holder, 5.5 mm	07781-0010101		
Cutter holder, 6.6 mm	07781-0010201		
Valve adjusting wrench	07908-KE90000	NOTE 2: 07908-KE90100	5
Snap ring pliers	07914-3230001	NOTE 1	2, 14, 15
Steering stem socket	07916-3710101		13
Clutch center holder	07JMB-MN50301	NOTE 3: 07HGB-001010A or 07HGB-001010B and 07HGB-001020A 07HGB-001020B	8
Bottom holder pipe	07930-KA50000	NOTE 2	13
- Holder attachment	07930-KA50100		
- Holder handle	07930-KA40200	NOTE 2	
Bearing remover set	07936-3710001	NOTE 2	12
- Remover handle	07936-3710100		
- Bearing remover set	07936-3710600		
- Remover weight	07741-0010201	NOTE 3: 07936-3710200	
Flywheel holder	07725-0040000	NOTE 1	
Valve guide driver attachment (IN)	07943-MF50100		10
(EX)	07943-MF50200		10
Bearing race remover	07946-3710500		13
Driver shaft set	07946-KA50000		14
Steering stem driver	07946-MB00000		13
Driver shaft	07946-MJ00100		14
Fork seal driver, 39 mm	07947-4630100		13
Ball race remover	07953-MJ10000	NOTE 2: 07953-MJ1000A or 07953-MJ1000B and 07949-3710001 or 07746-0010100	13
- Driver attachment	07953-MJ10100		
- Driver handle	07953-MJ10200		
Valve guide reamer, 5.5 mm (IN)	07984-2000001	NOTE 3: 07984-200000D	10
Valve guide reamer, 6.6 mm (EX)	07984-ZE20001	NOTE 3: 07984-ZE2000D	10
Oil filter wrench	07HAA-PJ70100		2
Peak voltage adapter	07HGJ-0020100		17
Main bearing driver attachment	07HMF-MM90400		12
Drive chain cutter	07HMH-MR10103	NOTE 3: 07HMH-MR1010B	3
Spoke wrench	07JMA-MR60100	NOTE 2	14
Vacuum/Pressure pump	A937X-041-XXXXX	NOTE 3: ST-AH-255-MC7 ST-AH-260-MC7	5

# LUBRICATION & SEAL POINTS

ENGINE	LOCATION	MATERIAL	REMARKS
<ul style="list-style-type: none"> <li>Camshaft lobes/journals</li> <li>Valve stem (valve guide sliding surface)</li> <li>Rocker arm slipper surface</li> <li>Rocker arm shaft sliding surface</li> <li>Connecting rod bearing surface</li> <li>Crankshaft journals</li> <li>Clutch outer guide outer surface</li> <li>Crankshaft hole cap threads</li> <li>Timing hole cap threads</li> <li>C2, M3 shifter gear (shift fork grooves)</li> <li>Transmission collars inner and outer surface</li> <li>Transmission spline collars outer surface</li> <li>Connecting rod small end inner surface</li> </ul>		<p>Molybdenum disulfide oil (a mixture of 1/2 engine oil and 1/2 molybdenum disulfide grease)</p>	
<ul style="list-style-type: none"> <li>Piston outer surface</li> <li>Piston ring outer surface</li> <li>Piston pin outer surface</li> <li>Primary drive gear bolt threads and seating surface</li> <li>Flywheel bolt threads and seating surface</li> <li>Starter reduction gear shaft outer surface</li> <li>Clutch disc outer surface</li> <li>Clutch center lock nut</li> <li>Cylinder stud bolt threads</li> <li>Cylinder head 8 × 187 mm mounting bolt threads</li> <li>Valve adjusting screw threads and seating surface</li> <li>Connecting rod bolt/nut threads and seating surface</li> <li>Cylinder head mounting bolt seating surface</li> <li>Each bearing rolling area</li> </ul>		<p>Engine oil</p>	
<ul style="list-style-type: none"> <li>Each oil seal lip</li> </ul>		<p>Multi-purpose grease</p>	
<ul style="list-style-type: none"> <li>Oil pressure switch threads</li> <li>3—4 mm (0.12—0.16 in)</li> </ul>  <ul style="list-style-type: none"> <li>Right and left crankcase mating surface</li> </ul>  <ul style="list-style-type: none"> <li>Fan motor switch threads</li> <li>Thermosensor threads ('97—'00)</li> <li>Thermo switch (Aftre '00)</li> </ul> <div style="text-align: right; border: 1px solid black; padding: 2px; display: inline-block;">NEW</div>		<p>Sealant</p>	

# GENERAL INFORMATION

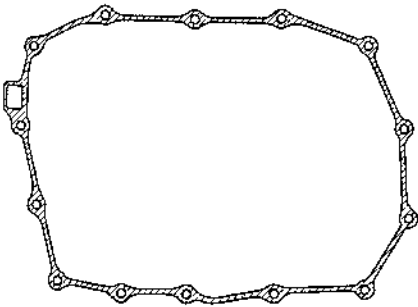
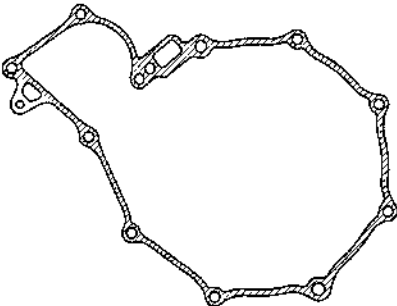
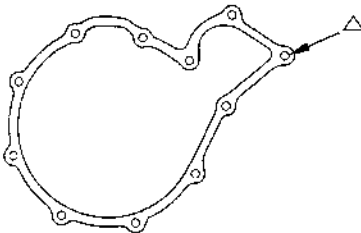
## ENGINE (Cont'd)

LOCATION	MATERIAL	REMARKS
<p>R. crankcase cover mating surface (After '98)</p>  <p>L. crankcase cover mating surface (After '98)</p>  <p>Fan motor switch threads Thermo sensor threads</p>	<p>Sealant</p>	<p>See page (8-21, 9-10)</p>
<p>Cam sprocket bolt threads Starter one-way clutch bolt threads Oil pump driven sprocket bolt threads Alternator cord clamber bolt threads Gearshift cam plate bolt threads Transmission bearing set plate bolt threads Countershaft oil seal set plate bolt threads Cam chain tensioner set plate bolt threads Stator mounting bolt threads Oil filter boss crankcase inside threads Ignition pulse generator bolt threads Left crankcase cover bolt threads (marked "△")</p> 	<p>Locking agent</p>	<p>Coating width: <math>6.5 \pm 1</math> mm</p> 

FRAME		
LOCATION	MATERIAL	REMARKS
Steering head bearing sliding surface Steering head dust seal lips Swingarm pivot bearing and dust seal lips Wheel dust seal lips Rear wheel axle sliding surface Side stand pivot sliding area Main and pillion footpeg sliding area Throttle pipe inner sliding surface Throttle pipe rolled up portion Clutch lever pivot bolt sliding surface Rear brake middle arm sliding area Rear brake pivot collar sliding area Brake pedal dust seal rubber Gearshift pedal dust seal rubber	Multi-purpose grease	Spreading 1.0 g  Spreading 1.0 – 2.0 g Spreading 0.2 – 0.3 g
Wheel axle distance collar Swingarm pivot distance collar Steering top threads Steering bottom bridge threads and seating surface Crankcase breather tube entry end	Engine oil	
Brake master cylinder cups Brake master piston Brake caliper piston seals Brake caliper dust seals	DOT 4 brake fluid	
Brake lever pivot and piston tips Brake caliper slide pin surface	Silicone grease	
Final driven flange bolt threads Fork socket bolt threads	Locking agent	
Handle grip rubber inside	Honda Bond A or Honda Hand Grip Cement (U.S.A. only)	
Front fork cap O-ring Front fork oil seal lips Front fork spring Front fork rebound spring	Pro-Honda Suspension Fluid SS-8	
Each cable inside	Cable lubricant	
Drive chain	Pro Honda Chain Lube or equivalent	

**GENERAL INFORMATION**

**CABLE & HARNESS ROUTING**

'97-'98:

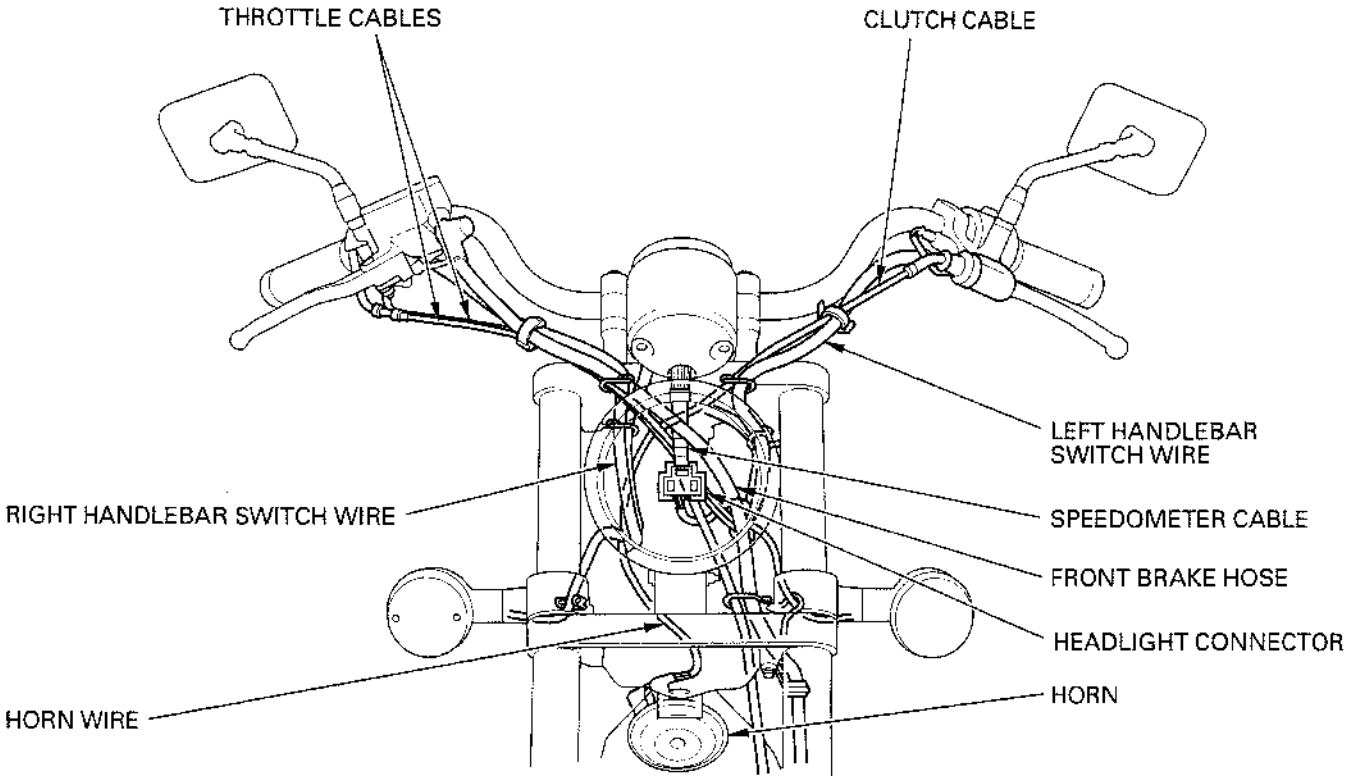

After '98:

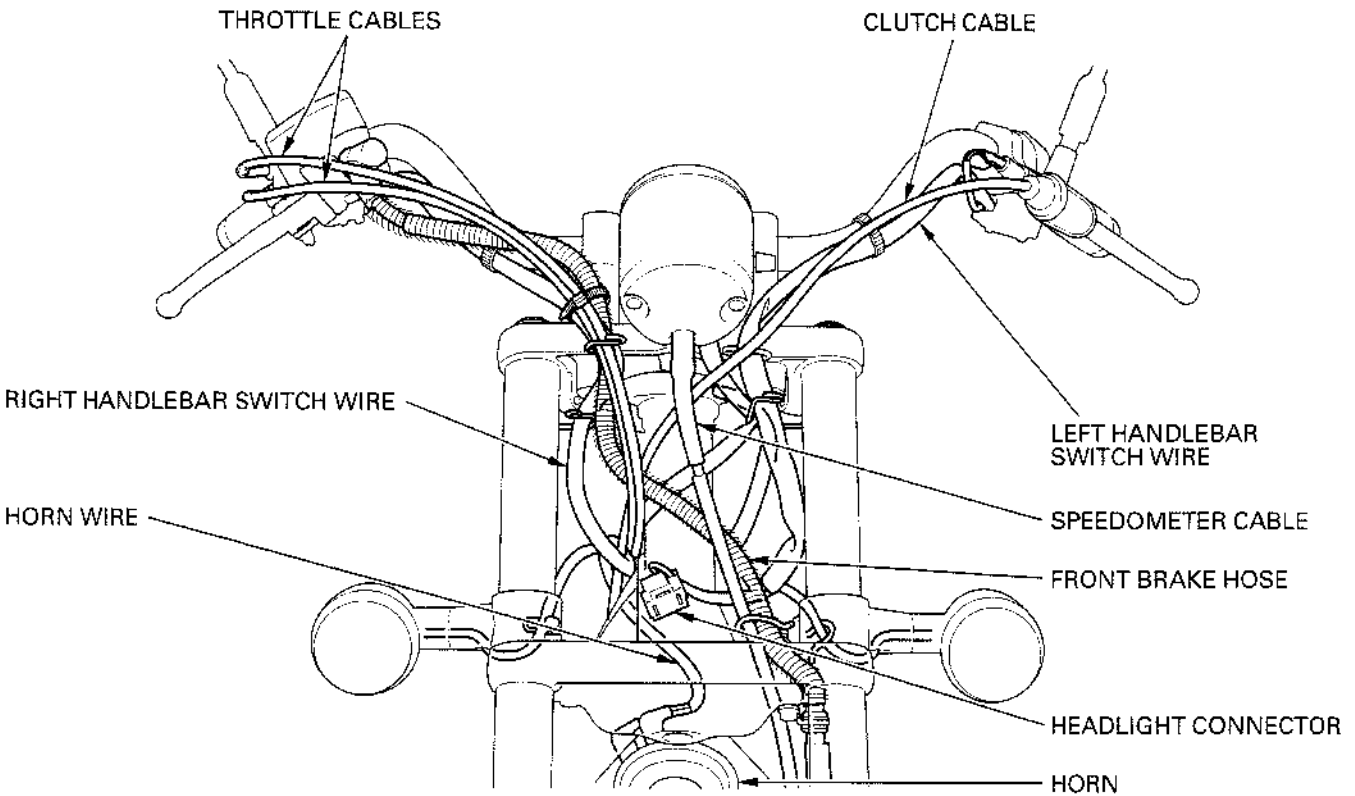



'97 — '98:

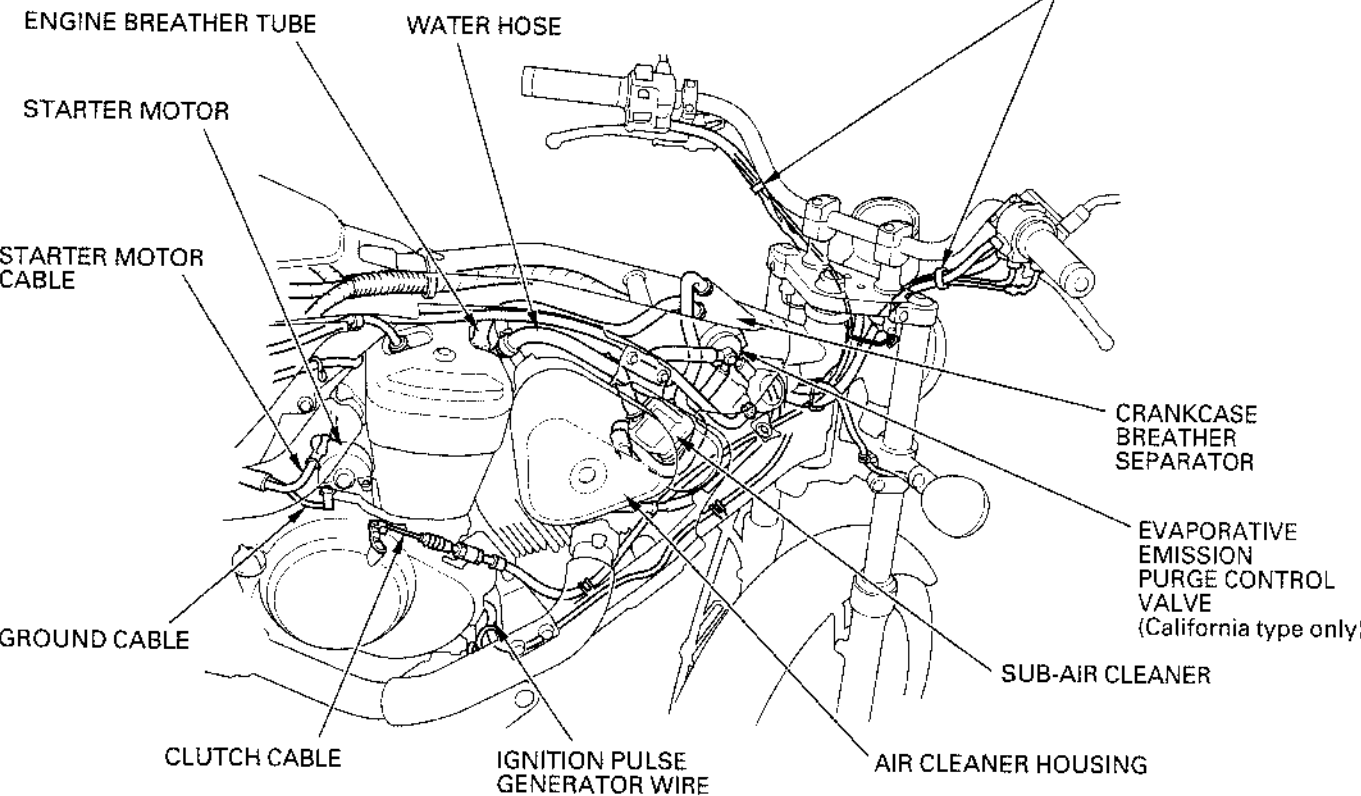

After '98:

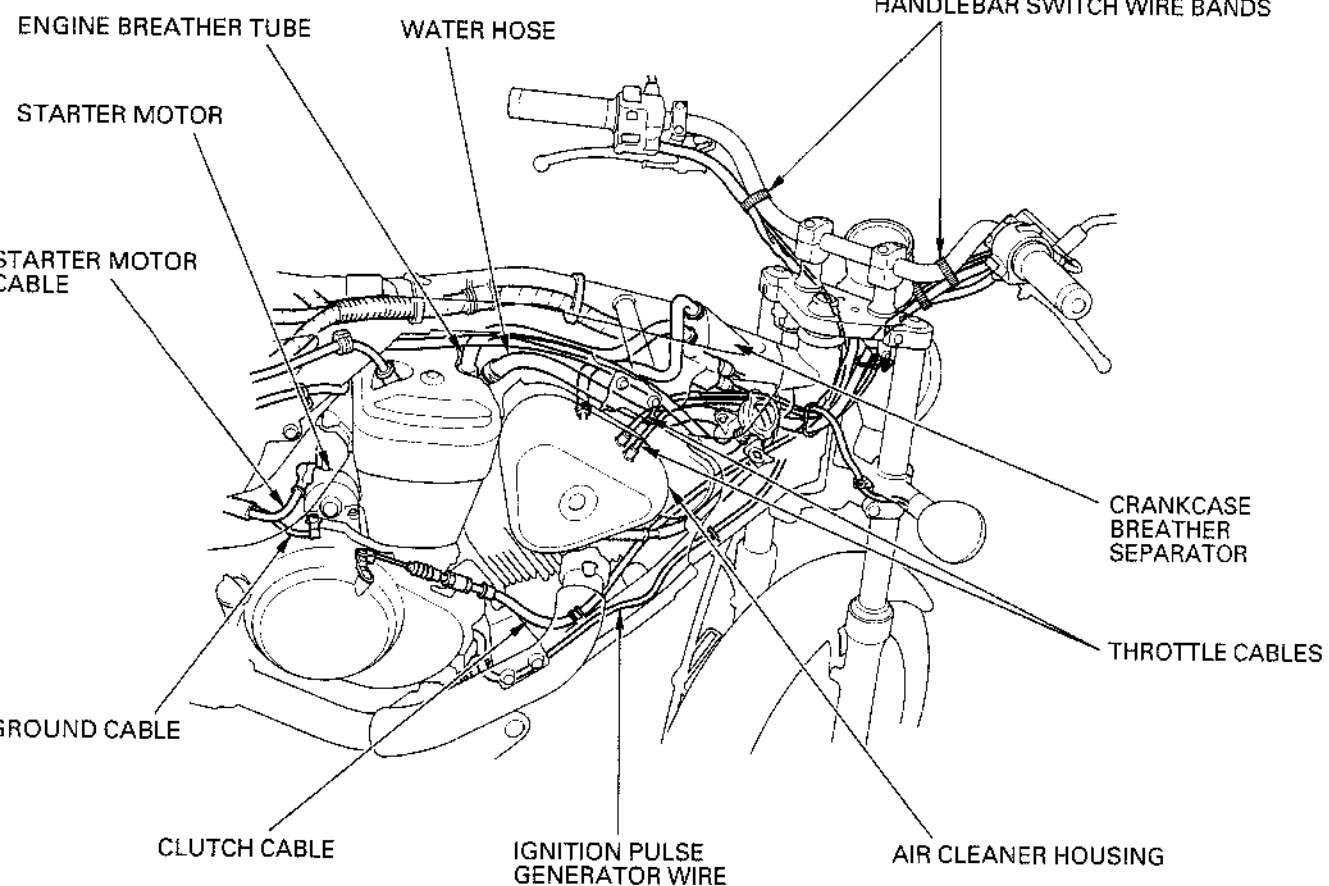

# GENERAL INFORMATION

'97 - '98:

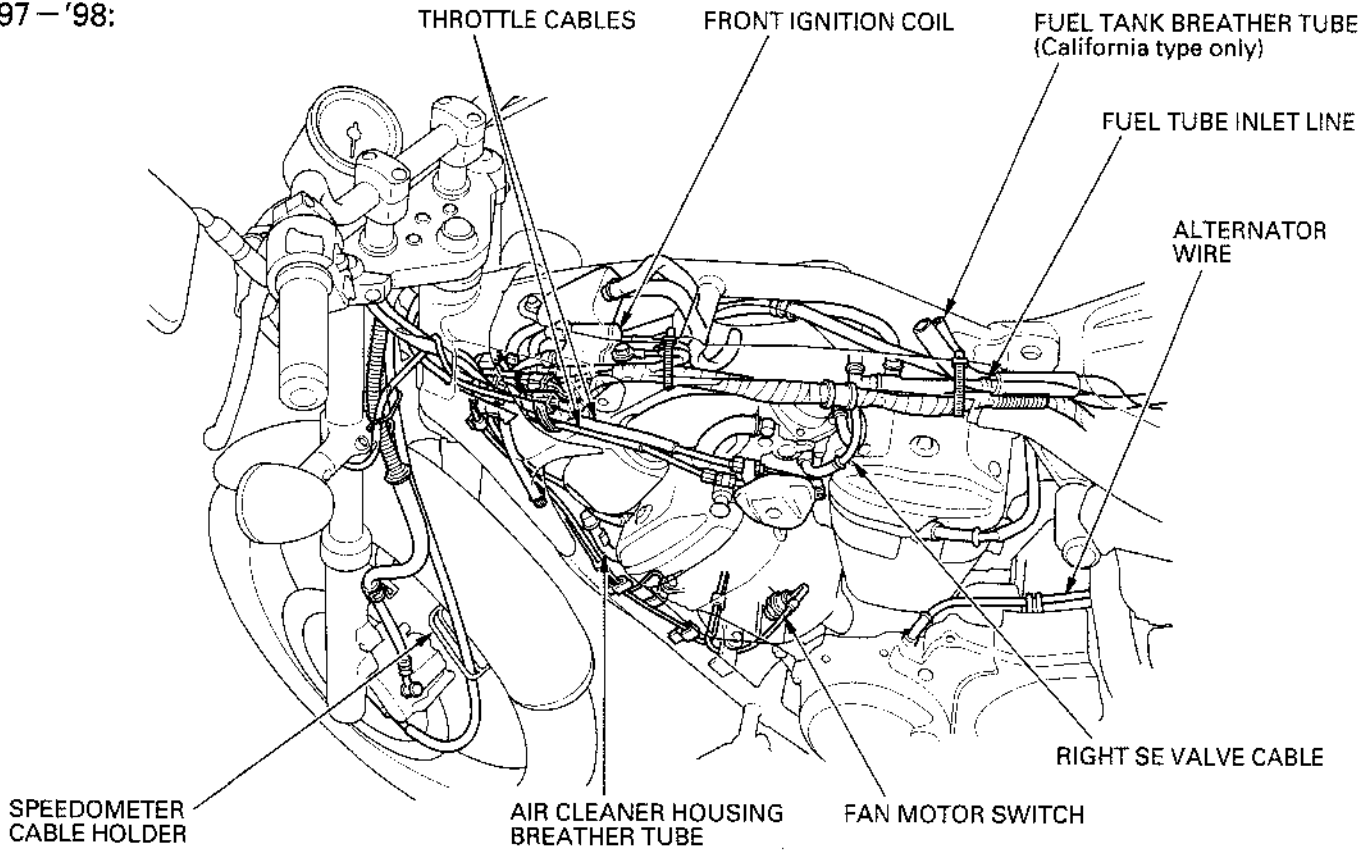

After '98:

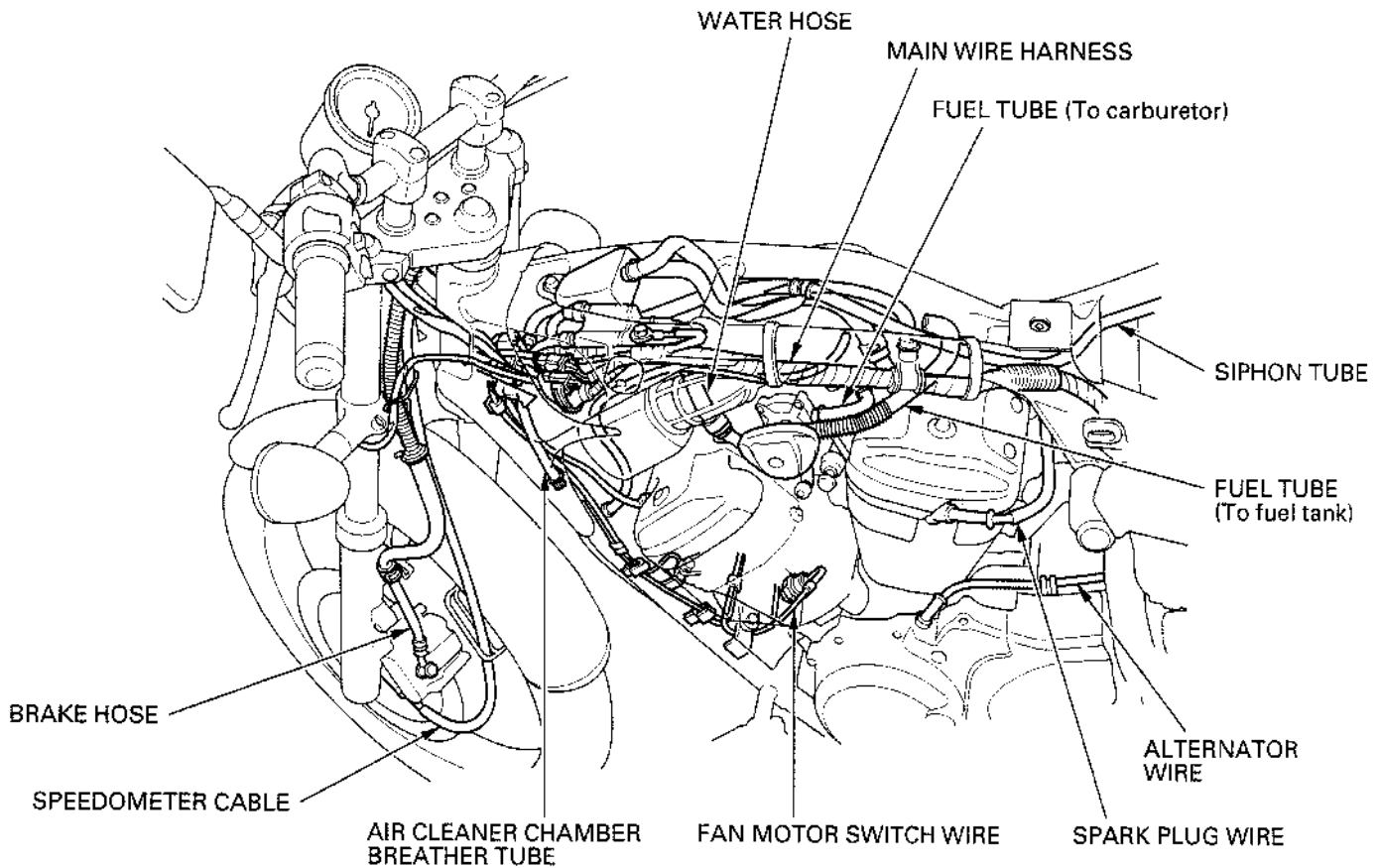

'97 - '98:

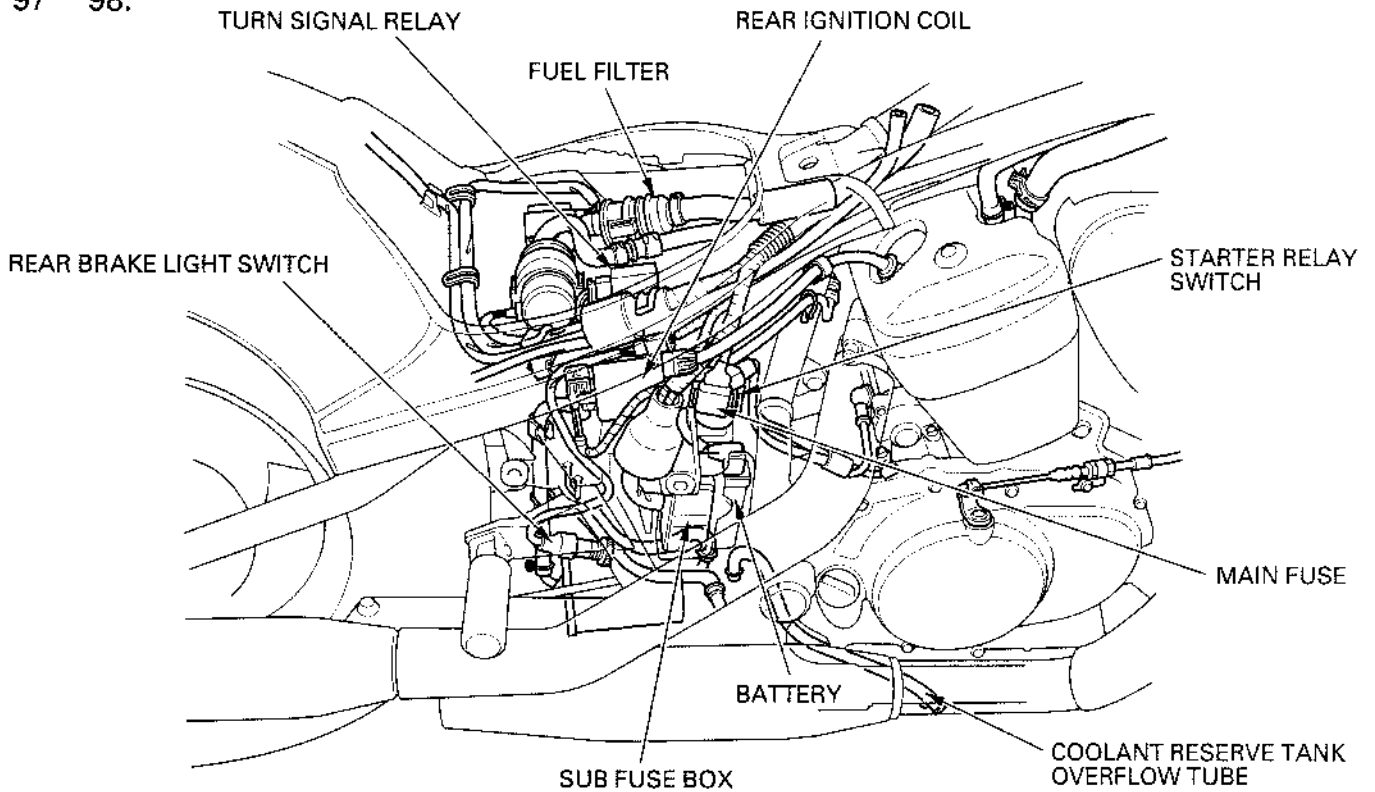

After '98:

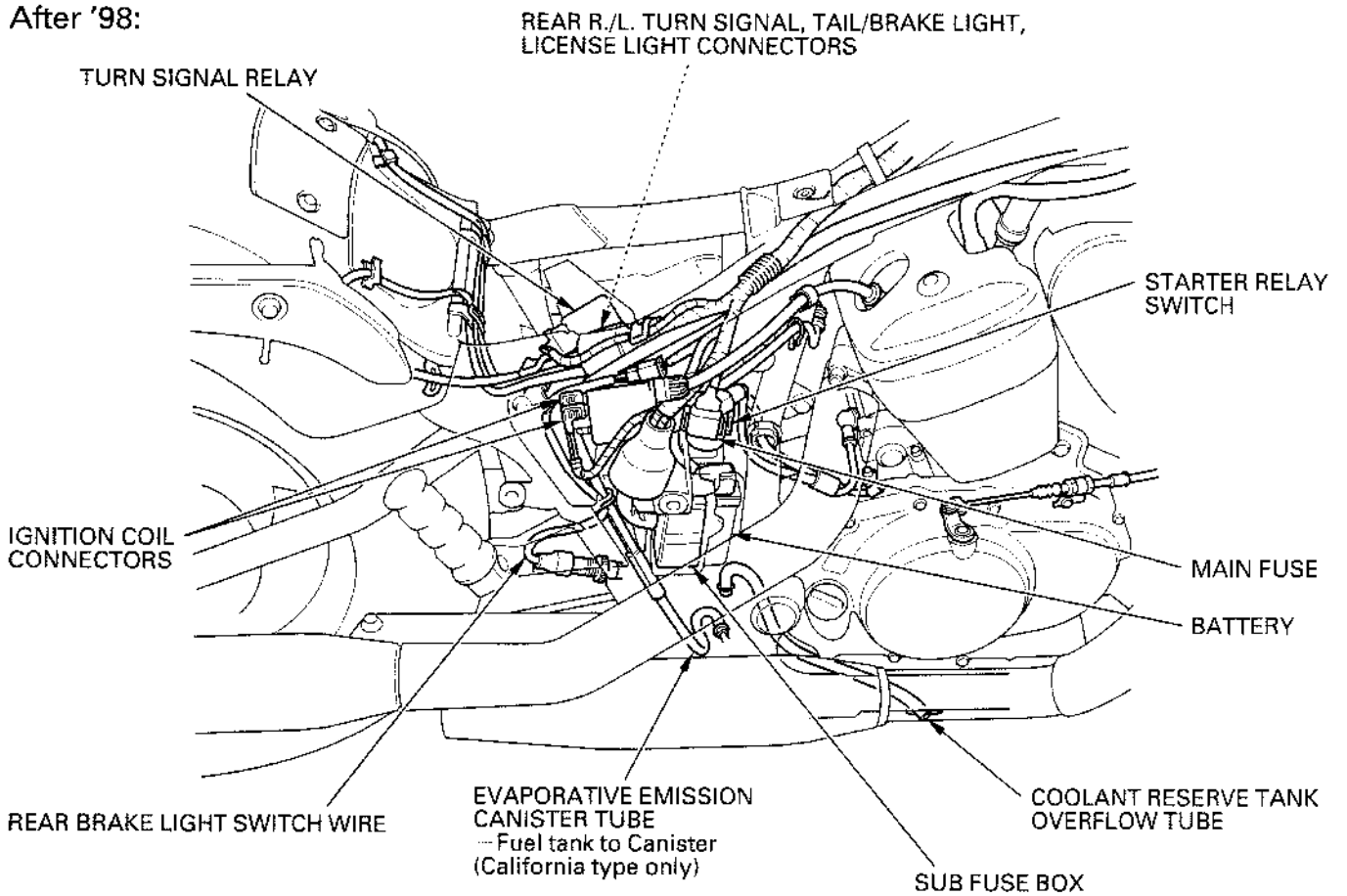

# GENERAL INFORMATION

'97 - '98:

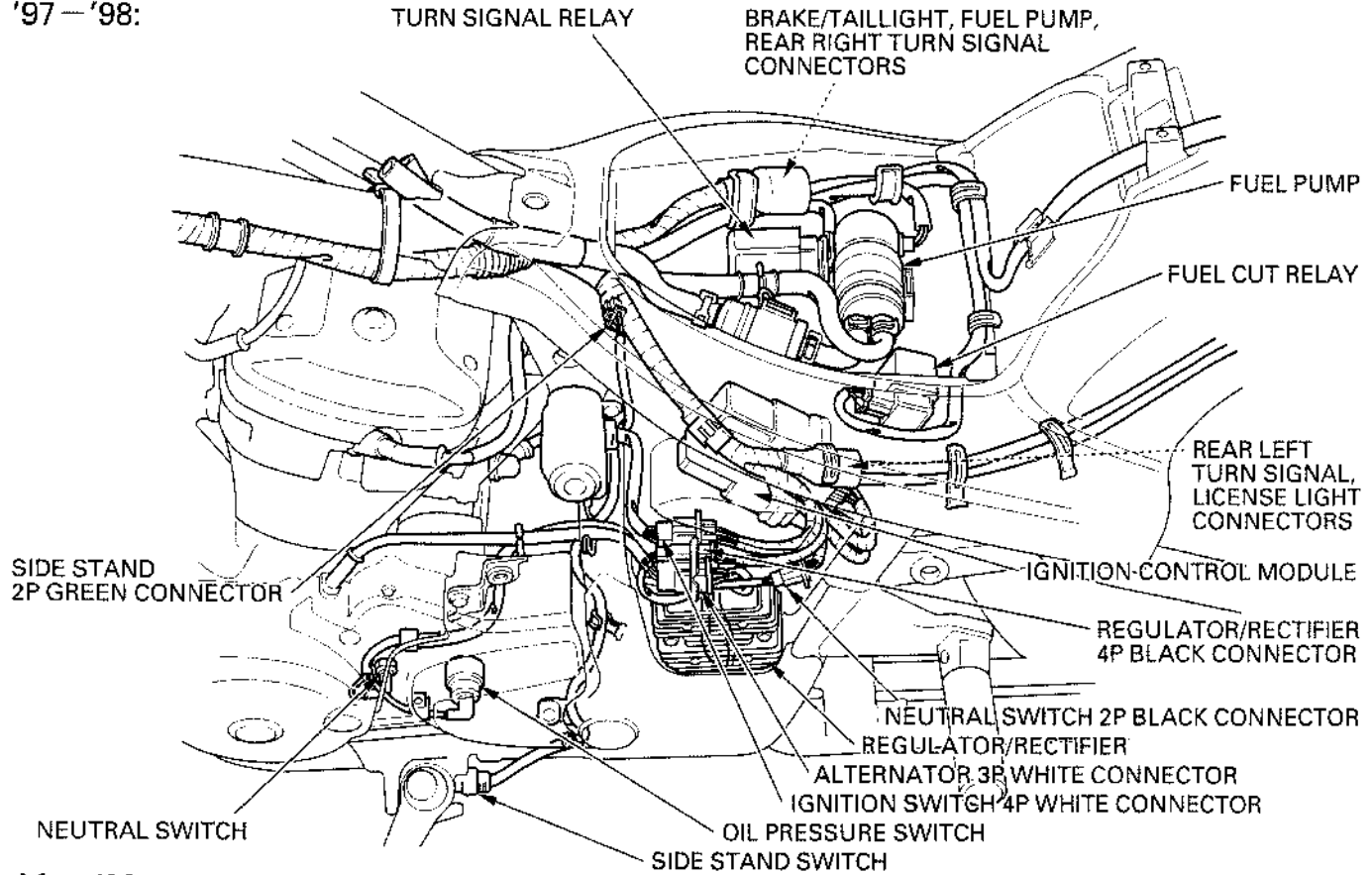

After '98:

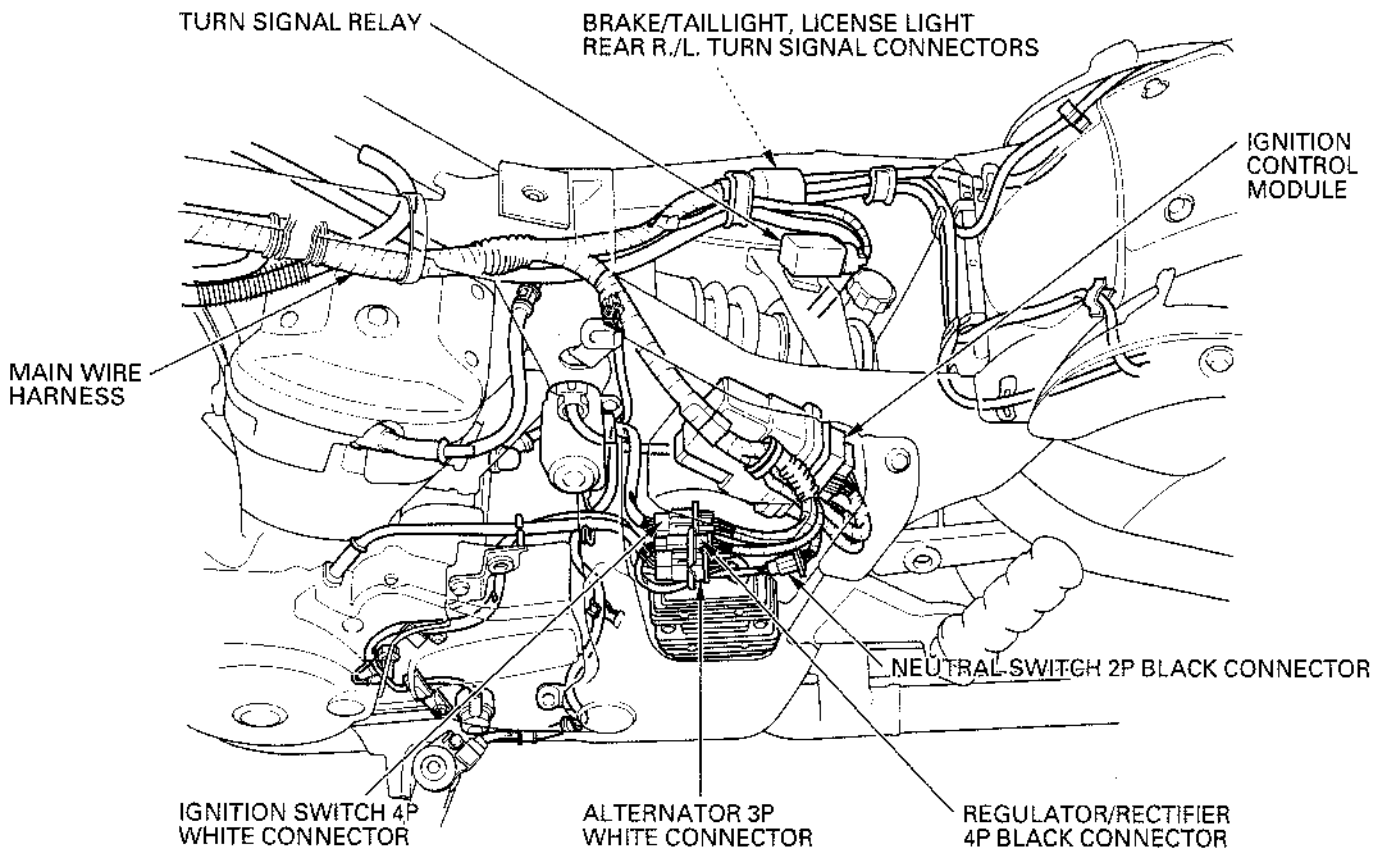

'97 - '98:

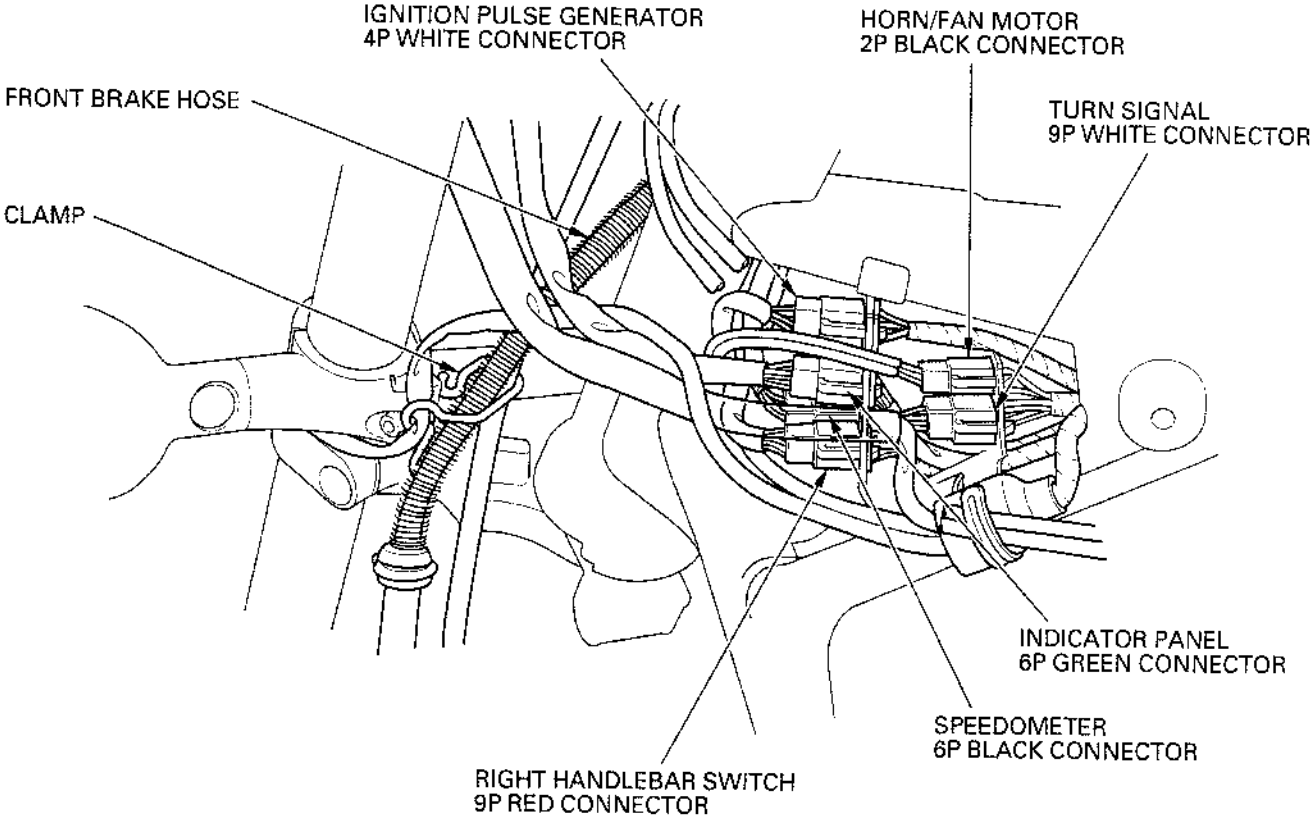

'97 - '98:

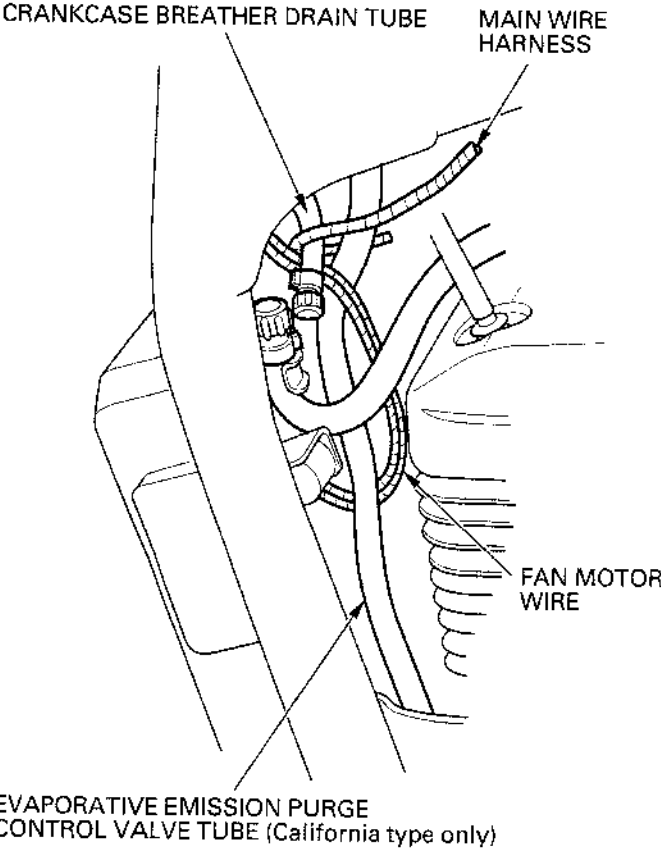

After '98:

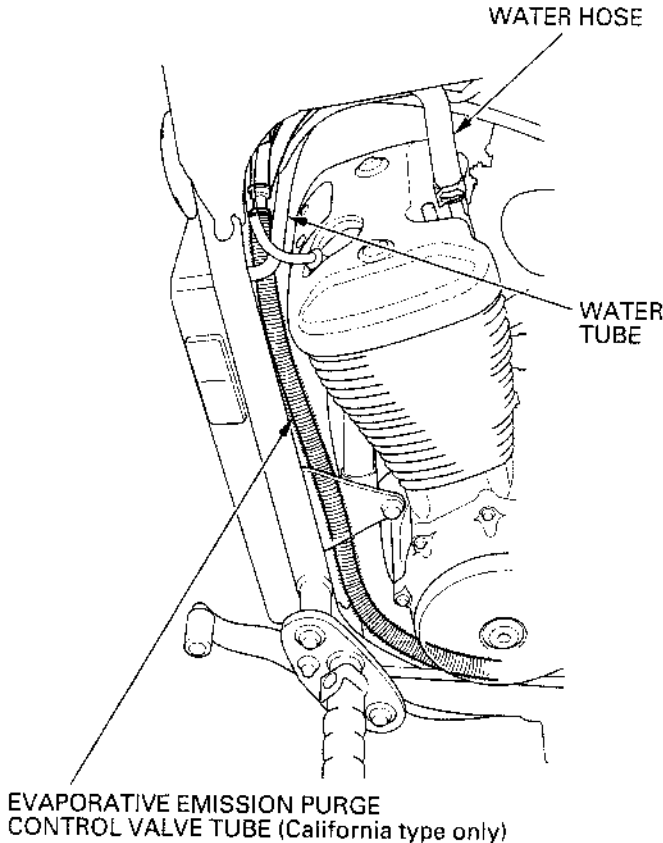

## GENERAL INFORMATION

---

'97 - '98:

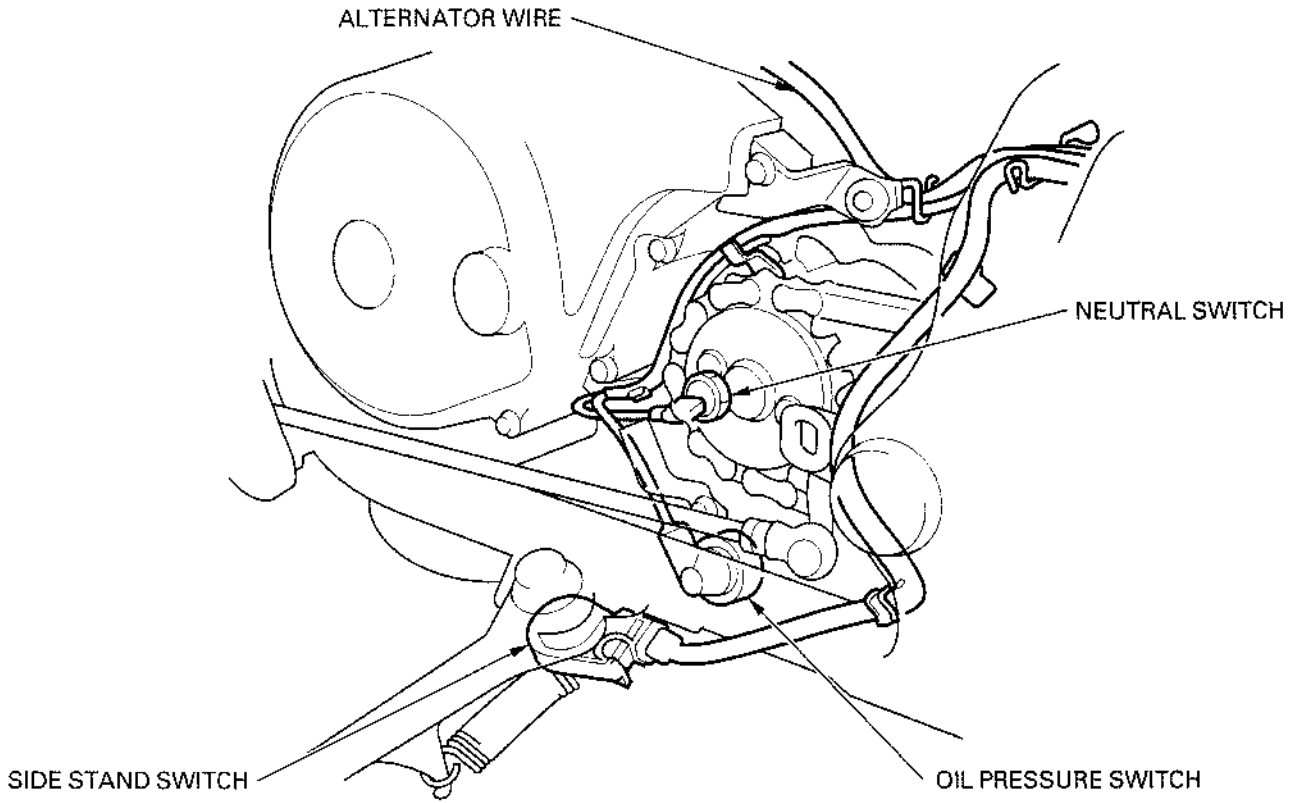

After '98:

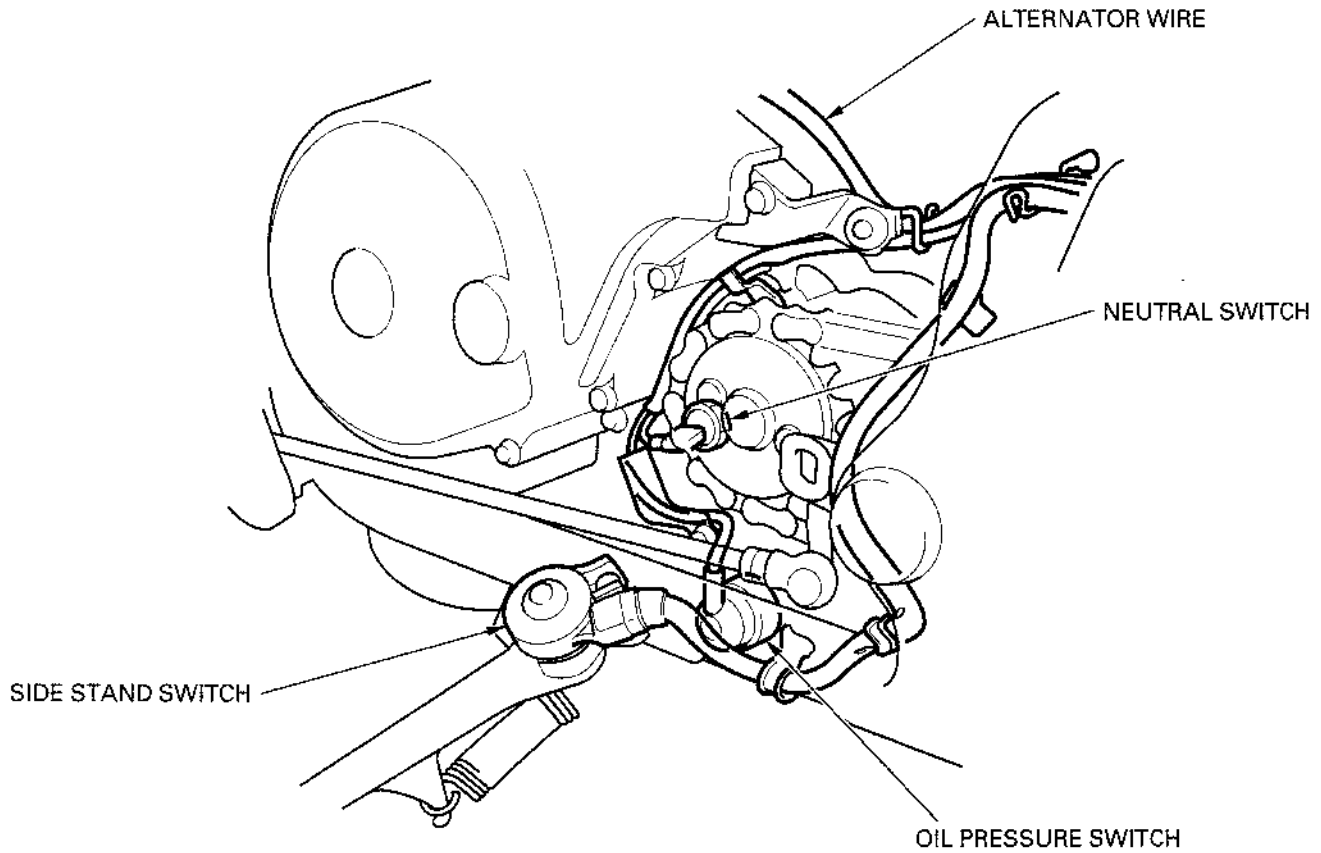

'97 - '98:

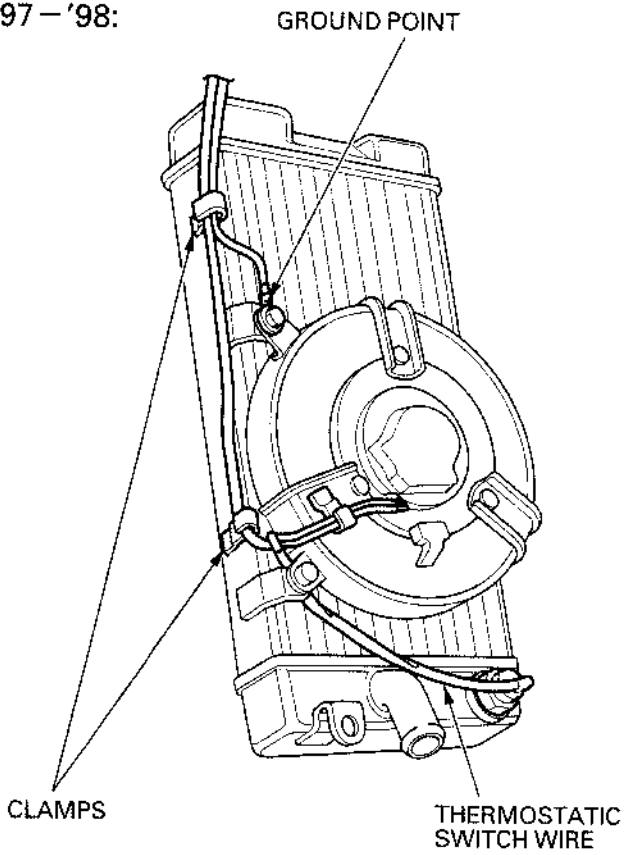

After '98:

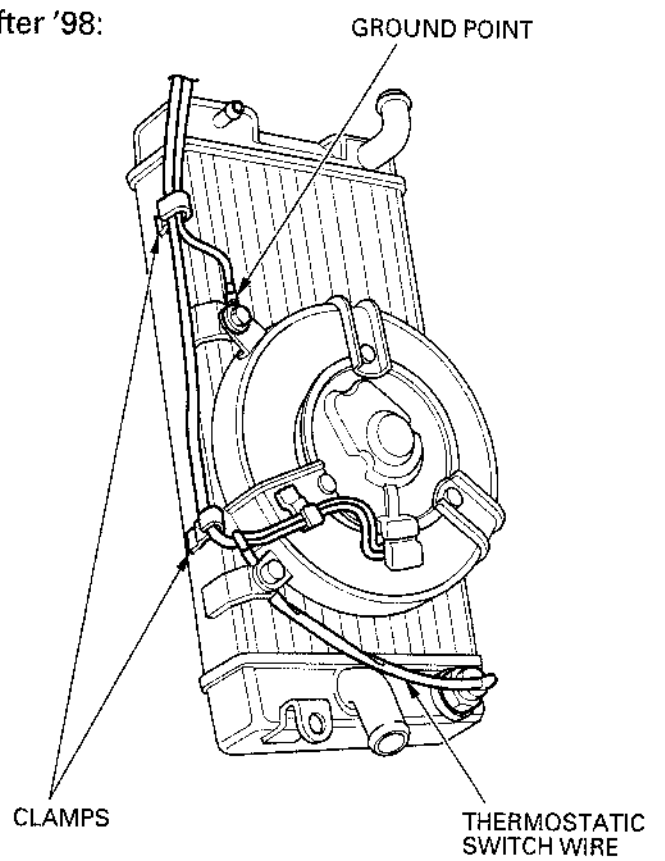

'97 - '98/After '98:

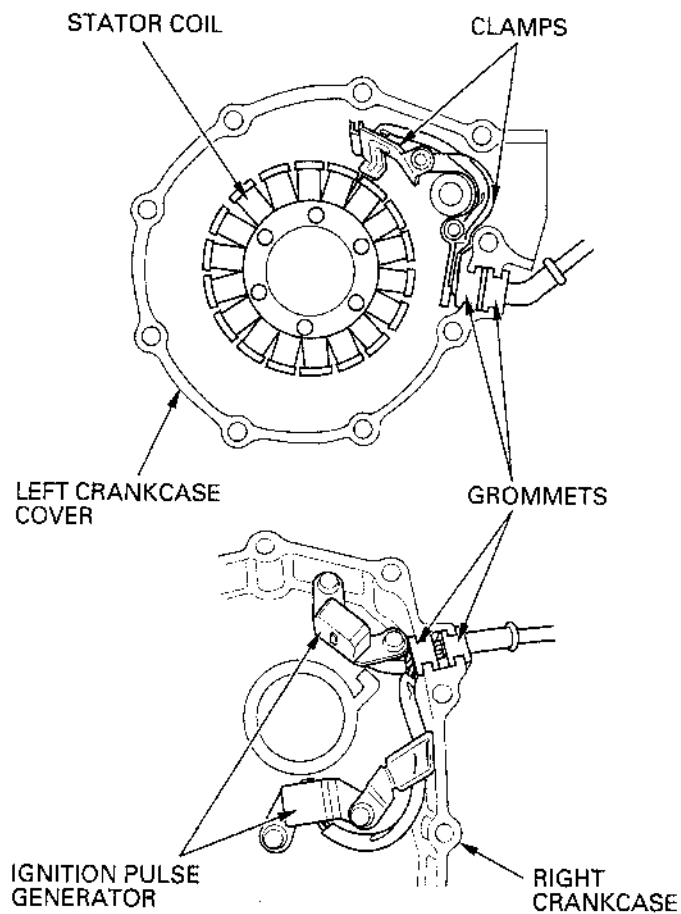

# GENERAL INFORMATION

'97-'98:

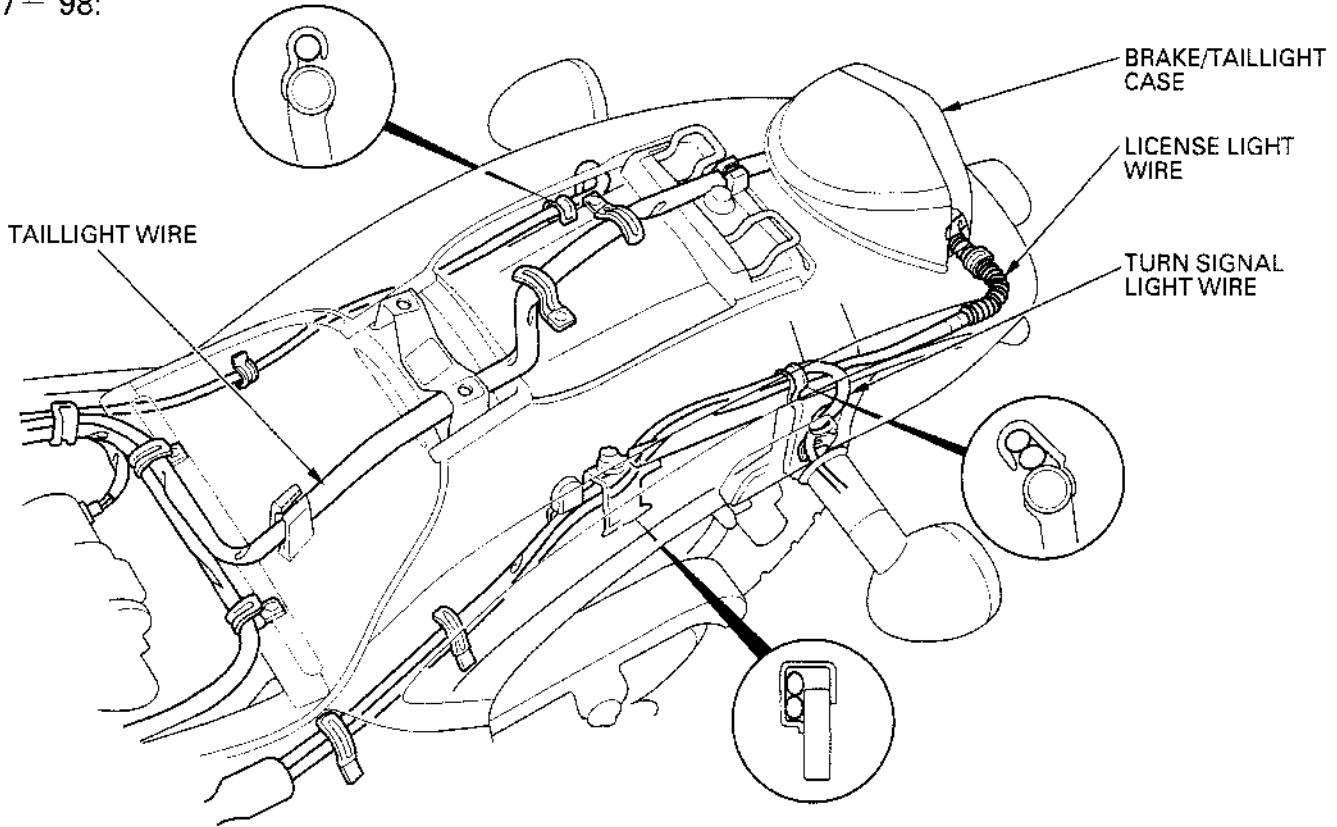

After '98:

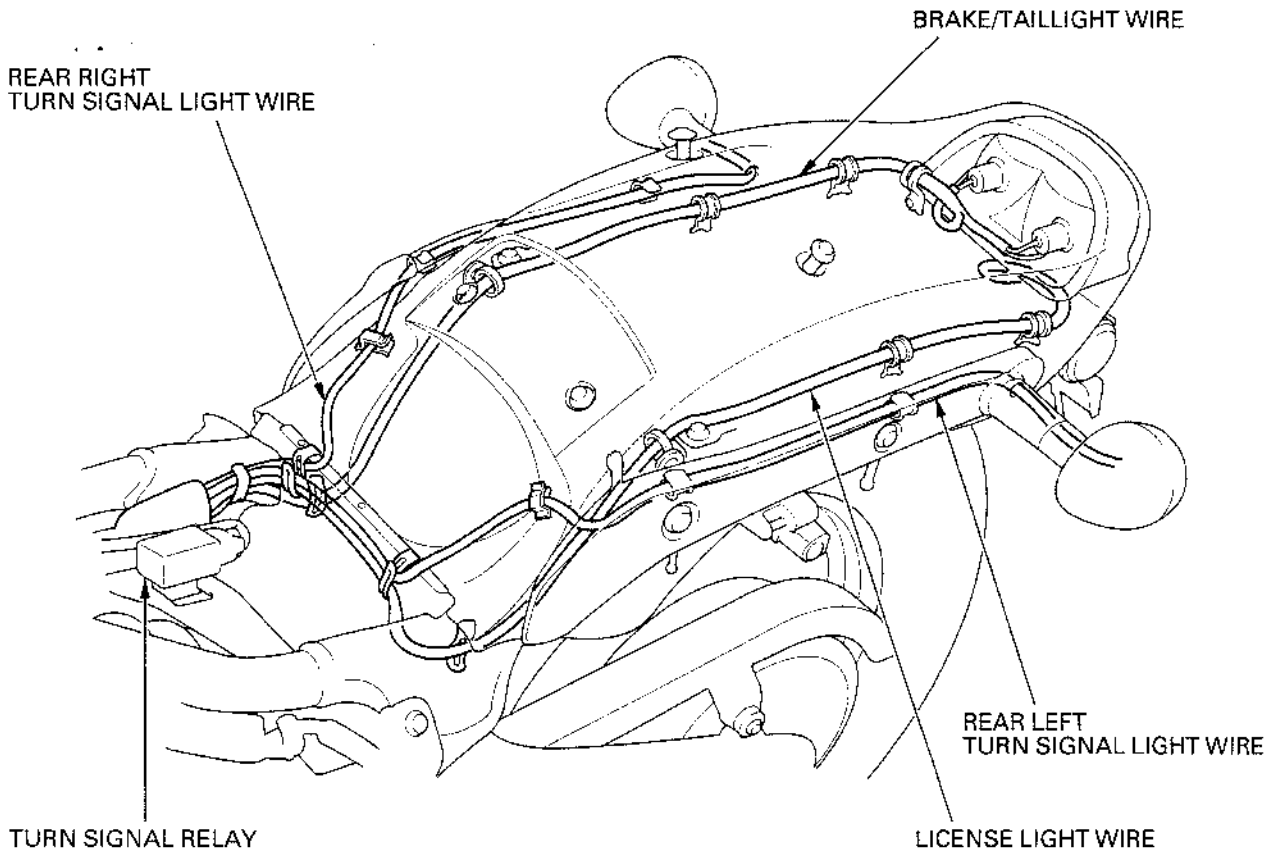



EVAPORATIVE EMISSION CONTROL SYSTEM (CALIFORNIA TYPE ONLY)

NOTE:

The hoses shown below are numbered as they appear on the Vacuum Hose Routing Diagram Label.

'97 - '98:

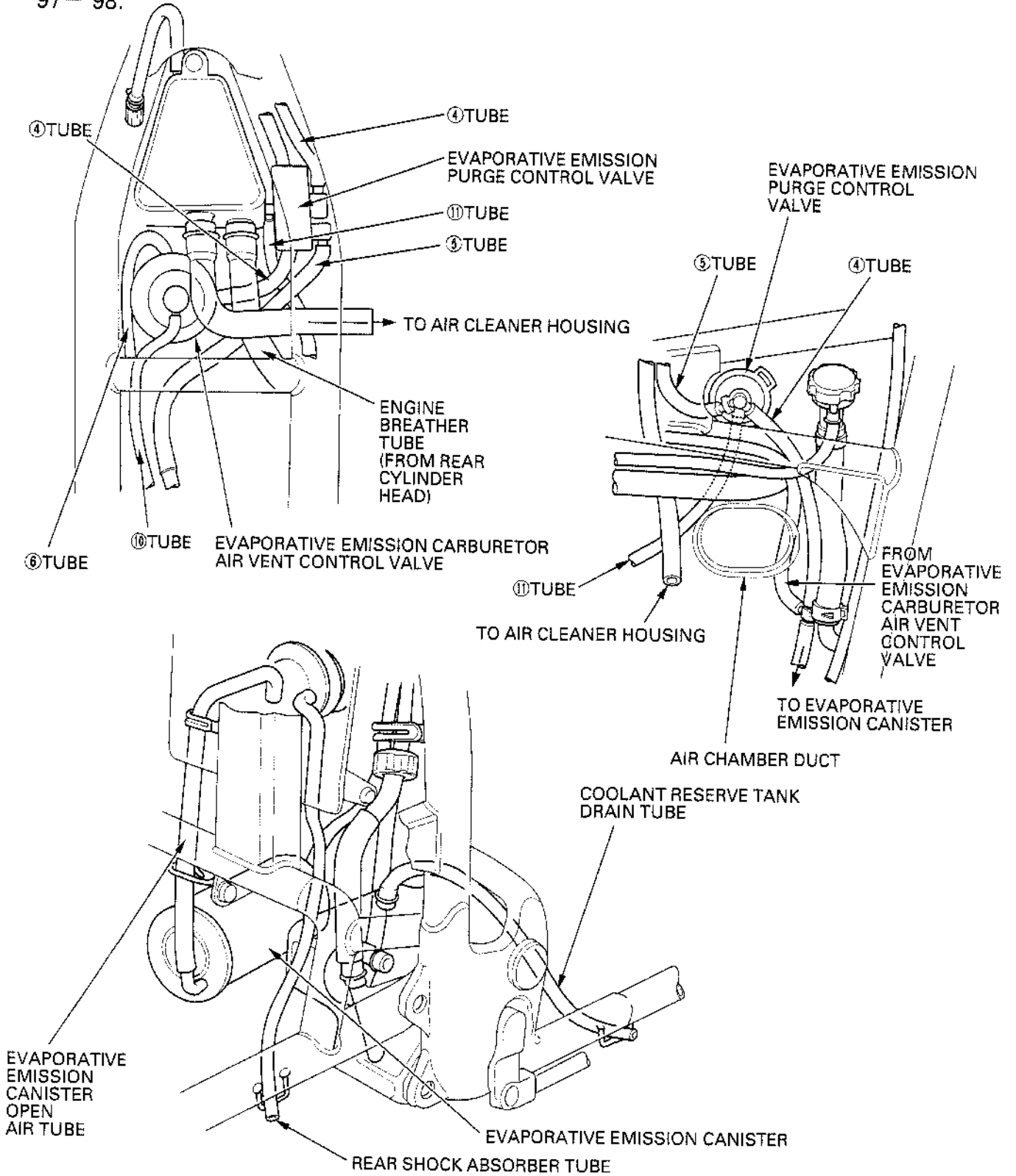

# GENERAL INFORMATION

After '98:

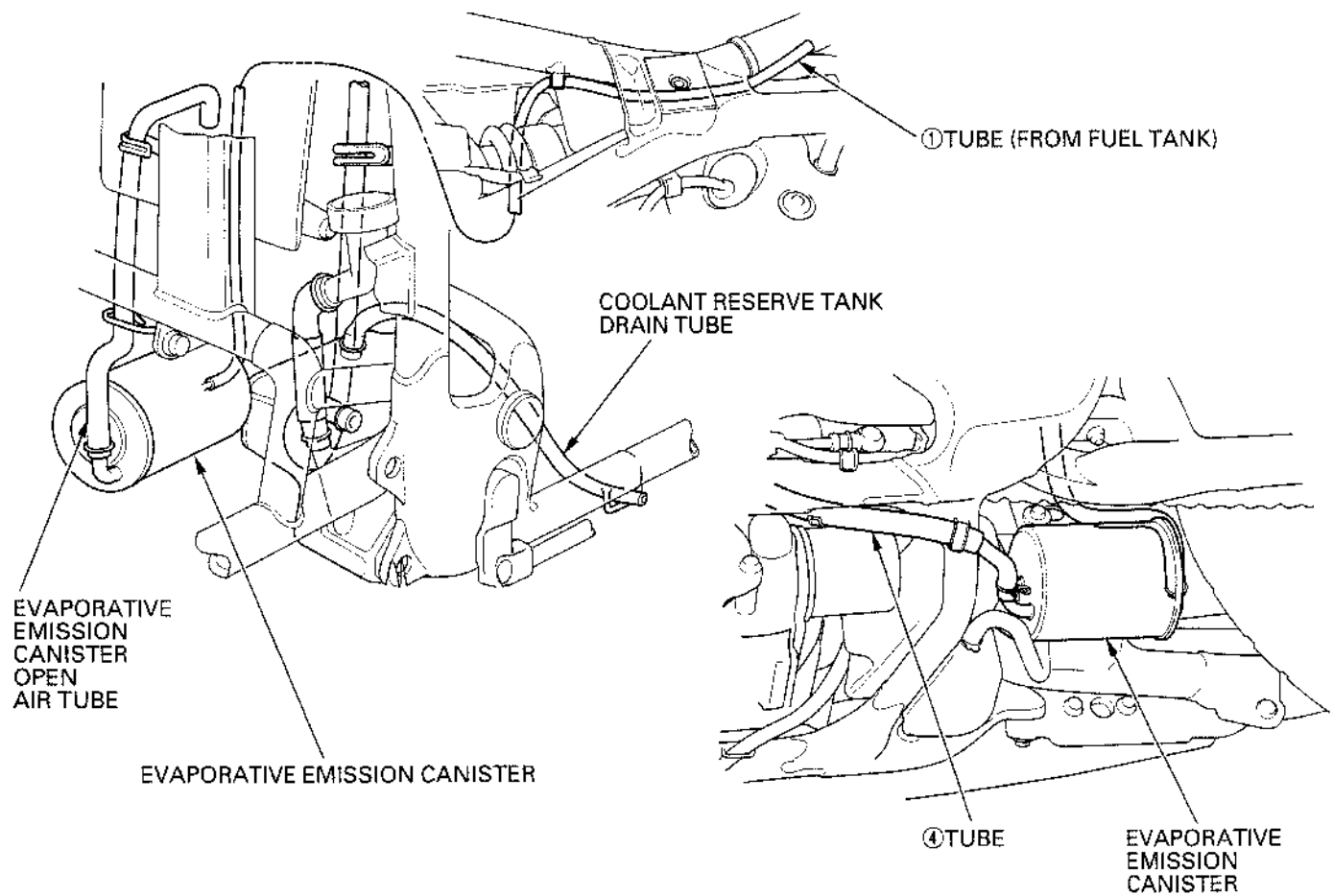
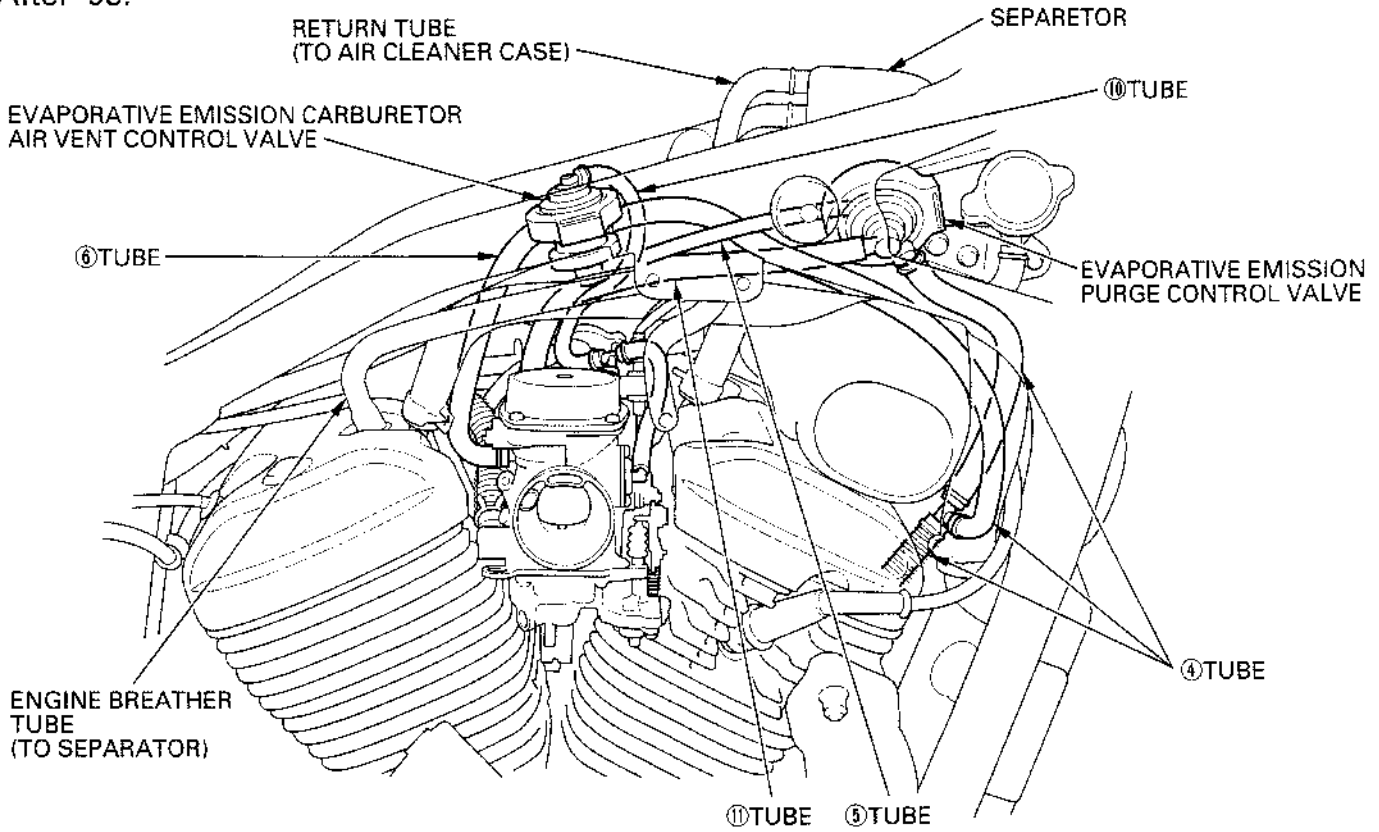

## EMISSION CONTROL SYSTEMS

The U.S. Environmental Protection Agency and California Air Resources Board (CARB) require manufacturers to certify that their motorcycles comply with applicable exhaust emissions standards during their useful life, when operated and maintained according to the instructions provided, and that motorcycles built after January 1, 1983 comply with applicable noise emission standards for one year or 6,000 km (3,730 miles) after the time of sale to the ultimate purchaser, when operated and maintained according to the instructions provided. Compliance with the terms of the Distributor's Limited Warranty for Honda Motorcycle Emission Control Systems is necessary in order to keep the emissions system warranty in effect.

### SOURCE OF EMISSIONS

The combustion process produces carbon monoxide and hydrocarbons control of hydrocarbons is very important because, under certain conditions, they react to form photochemical smog when subjected to sunlight. Carbon monoxide does not react in the same way, but it is toxic.

Honda Motor Co., Ltd. utilizes lean carburetor settings as well as other systems, to reduce carbon monoxide and hydrocarbons.

### EXHAUST EMISSION CONTROL SYSTEM

The exhaust emission control system is composed of a lean carburetor setting, and no adjustments should be made except idle speed adjustment with the throttle stop screw. The exhaust emission control system is separate from the crankcase emission control system.

### CRANKCASE EMISSION CONTROL SYSTEM

The engine is equipped with a closed crankcase system to prevent discharging crankcase emissions into the atmosphere. Blow-by gas is returned to the combustion chamber through the air cleaner and carburetor.

'97 - '98:

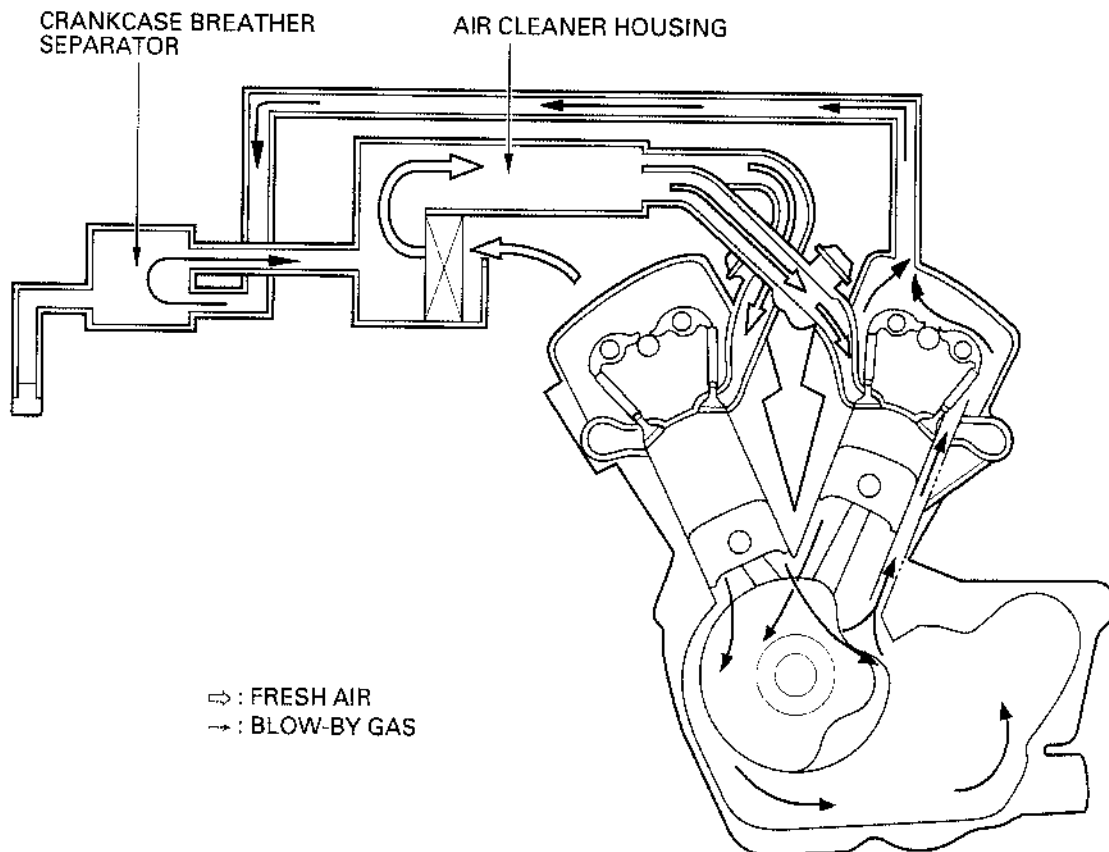

## GENERAL INFORMATION

After '98:

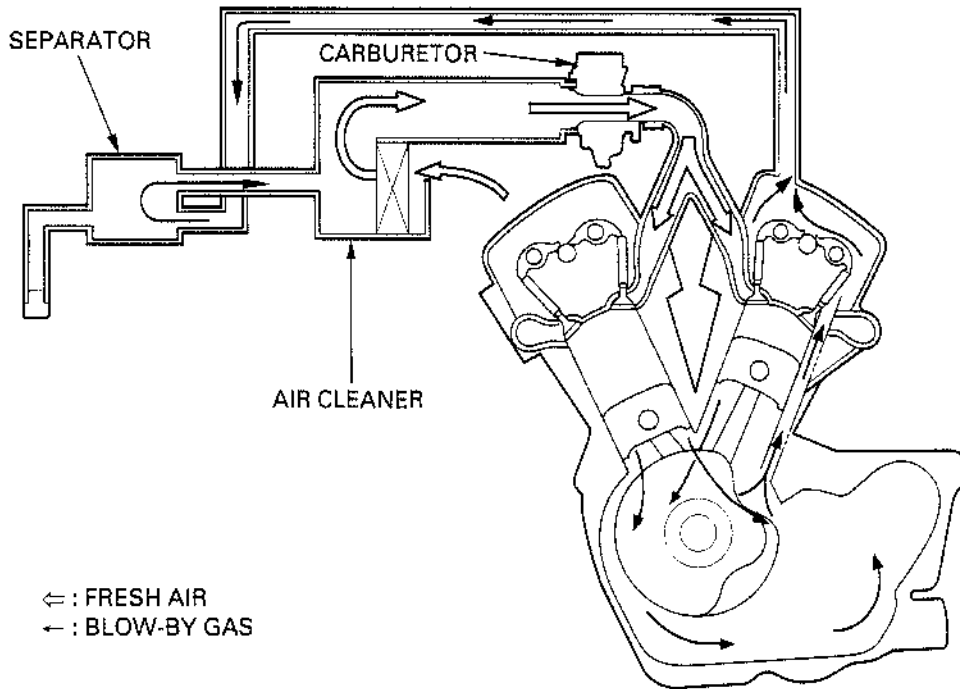

## EVAPORATIVE EMISSION CONTROL SYSTEM (CALIFORNIA TYPE ONLY)

This model complies with California Air Resources Board evaporative emission requirements.

Fuel vapor from the fuel tank and carburetor(s) ('97-'98) are routed into the evaporative emission (EVAP) canister where it is absorbed and stored while the engine is stopped. When the engine is running and the evaporative emission (EVAP) purge control valve is open, fuel vapor in the EVAP canister is drawn into the engine through the carburetor. At the same time, EVAP carburetor air vent (CAV) control valve is open and air is drawn into the carburetor through the valve.

'97-'98:

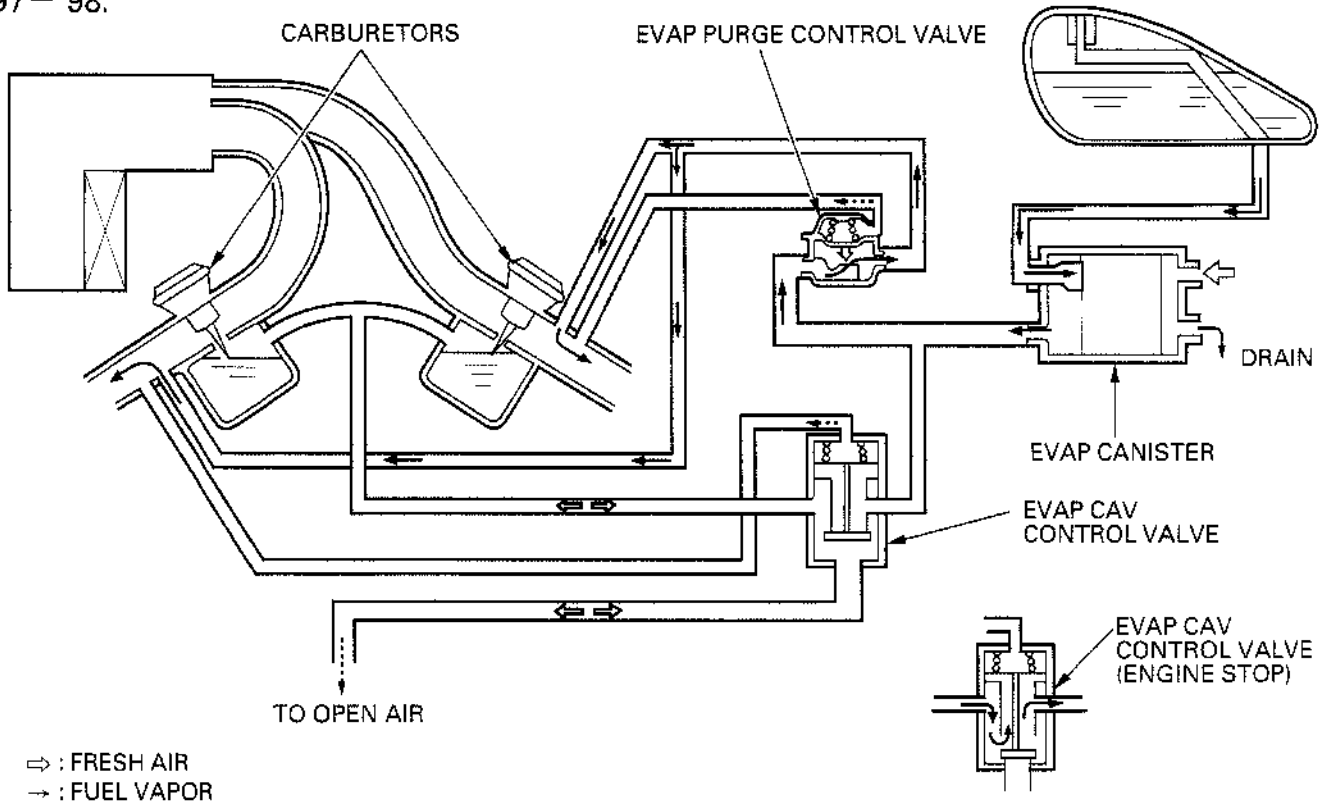

After '98:

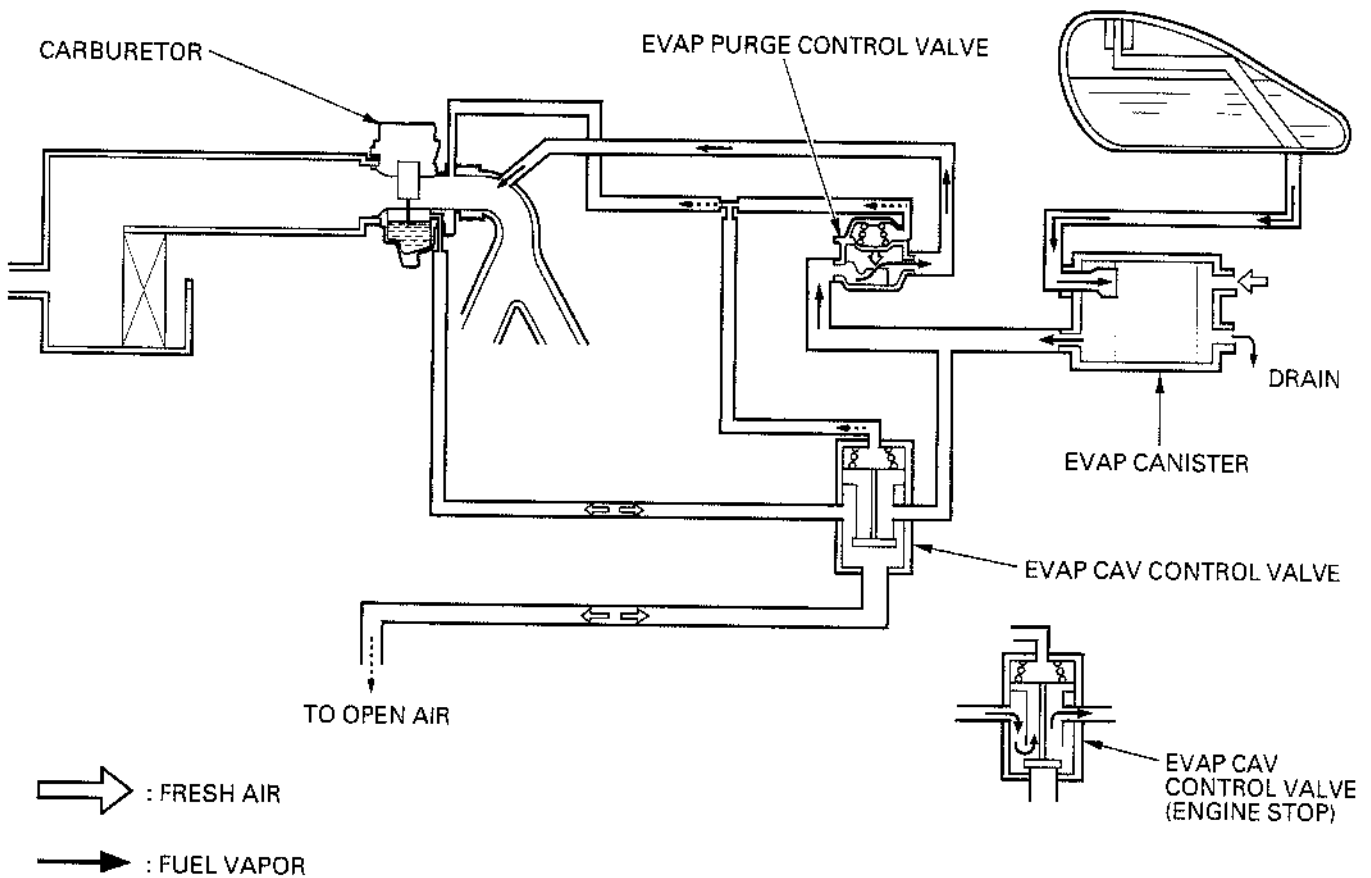

## NOISE EMISSION CONTROL SYSTEM

**TAMPERING WITH THE NOISE CONTROL SYSTEM IS PROHIBITED:** Federal law prohibits the following acts or the causing thereof: (1) The removal or rendering inoperative by any person, other than for purposes of maintenance, repair or replacement, of any device or element of design incorporated into any new vehicle for the purpose of noise control prior to its sale or delivery to the ultimate purchaser or while it is in use; (2) the use of the vehicle after such device or element of design has been removed or rendered inoperative by any person.

AMONG THOSE ACTS PRESUMED TO CONSTITUTE TAMPERING ARE THE ACTS LISTED BELOW:

1. Removal of, or puncturing of the muffler, baffles, header pipes or any other component which conduct exhaust gases.
2. Removal of, or puncturing of any part of the intake system.
3. Lack of proper maintenance.
4. Replacing any moving parts of the vehicle, or parts of the exhaust or intake system, with parts other than those specified by the manufacturer.

## GENERAL INFORMATION

### EMISSION CONTROL INFORMATION LABELS

An Emission Control Information Label is located on the inside of the left side cover as shown.

The left side cover must be removed to read it. Refer to page 2-3 for left side cover removal.

It gives base tune-up specifications.

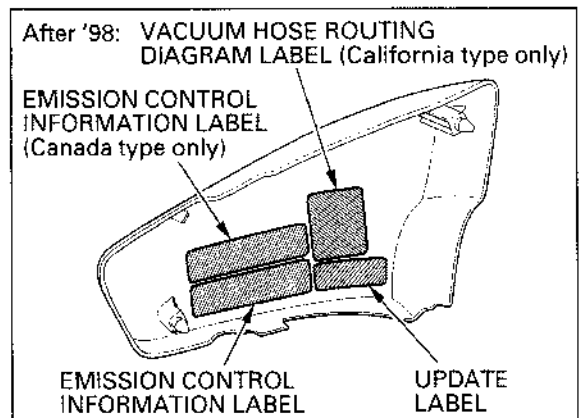
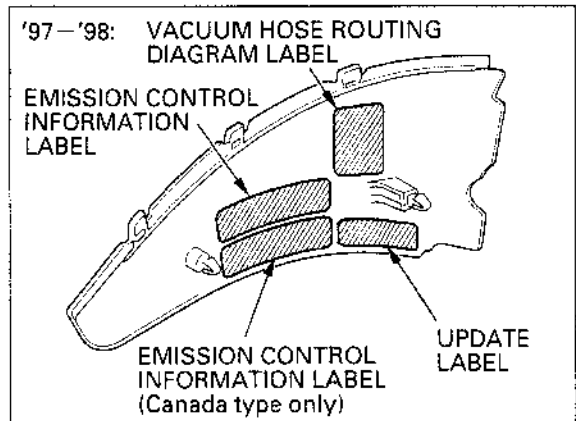

### VEHICLE EMISSION CONTROL INFORMATION UPDATE LABEL

After making a high altitude carburetor adjustment, attach an update label on the inside of the left side cover as shown.

The left side cover must be removed to read it. Refer to page 2-3 for left side cover removal.

Instructions for obtaining the update label are given in Service Letter No 132.

When readjusting the carburetor(s/'97-'98) back to the low altitude specifications, be sure to remove this update label.

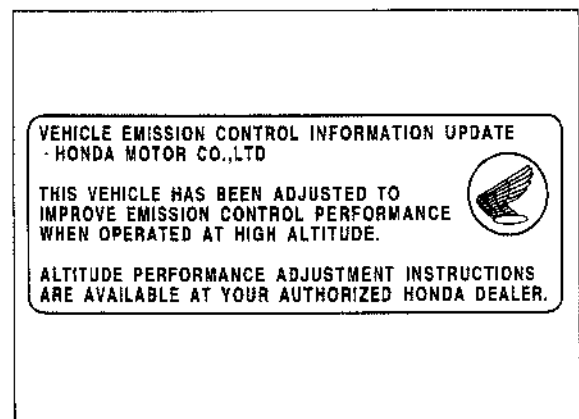

**VACUUM HOSE ROUTING DIAGRAM LABEL (CALIFORNIA TYPE ONLY)**

The Vacuum Hose Routing Diagram Label is on the inside of the left side cover as shown.

The left side cover must be removed to read it. Refer to page 2-3 for left side cover removal.

'97-'98:

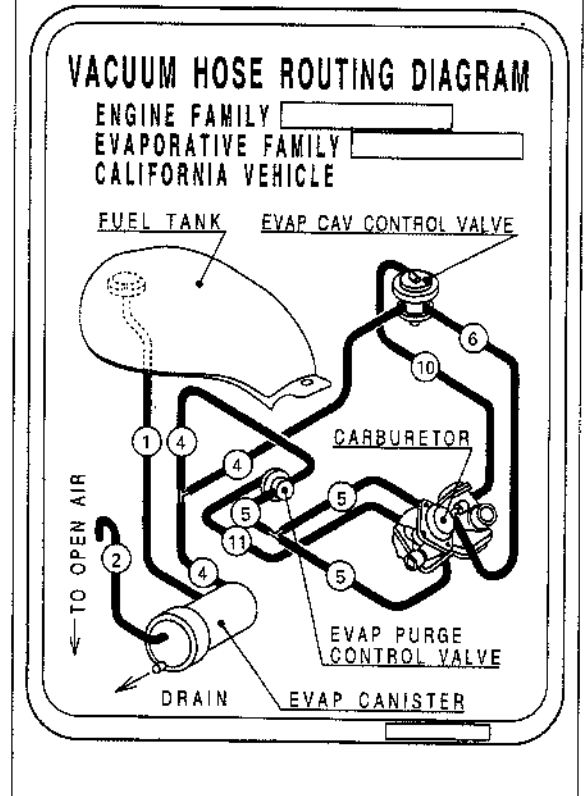

After '98:

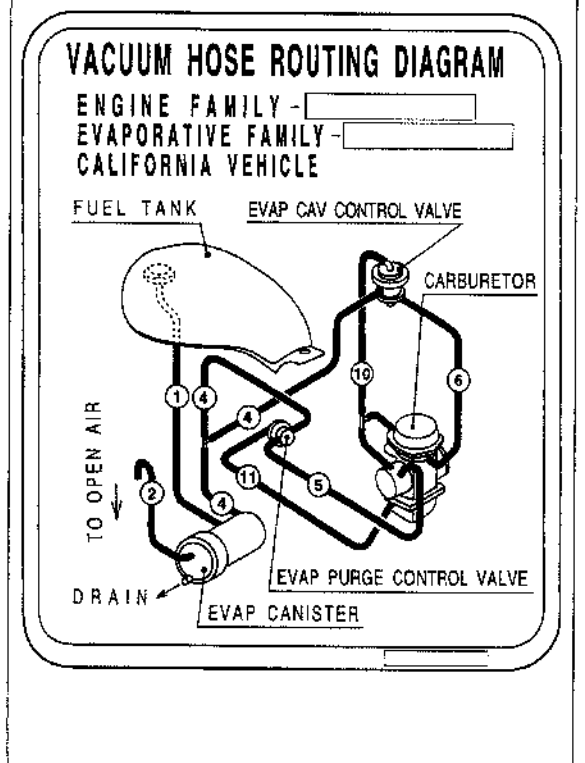

---

**MEMO**

---



# 2. FRAME/BODY PANELS/EXHAUST SYSTEM

SERVICE INFORMATION	2-1	SIDE COVER	2-3
TROUBLESHOOTING	2-1	FUEL TANK	2-4
SEAT ('97 - '98)	2-2	REAR FENDER/REAR SUB-FRAME	2-8
SEAT (After '98)	2-2	EXHAUST PIPE/MUFFLER	2-14
STEERING COVER	2-3		

## SERVICE INFORMATION

### GENERAL

#### ▲WARNING

- Gasoline is extremely flammable and is explosive under certain conditions. Work in a well ventilated area. Smoking or allowing flames or sparks in the work area or where the gasoline is stored can cause a fire or explosion.
- Engine and exhaust system parts become very hot and remain hot for some time after the engine is run. Wear insulated gloves or wait until the engine and exhaust system have cooled before handling these parts.
- When the engine must be running to do some work, make sure the area is well-ventilated. Never run the engine in an enclosed area. The exhaust contains poisonous carbon monoxide gas that may cause loss of consciousness and lead to death. Run the engine in an open area or with an exhaust evacuation system in an enclosed area.

- Work in a well ventilated area. Smoking or allowing flames or sparks in the working area or where gasoline is stored can cause a fire or explosion.
- This section covers removal and installation of the frame body panels, fuel tank and exhaust system.
- Always replace the exhaust pipe gaskets when removing the exhaust pipe from the engine.
- Always inspect the exhaust system for leaks after installation.

### TORQUE VALUES

Exhaust pipe joint nut		25 N·m (2.5 kgf·m , 18 lbf·ft)
Fuel tank mounting bolt		19 N·m (1.9 kgf·m , 14 lbf·ft)
Fuel valve nut	'97 - '98	23 N·m (2.3 kgf·m , 17 lbf·ft)
	After '98	35 N·m (3.6 kgf·m , 26 lbf·ft)
Fuel valve lever screw		4 N·m (0.4 kgf·m , 2.9 lbf·ft)
Exhaust pipe cover bolt		12 N·m (1.2 kgf·m , 9 lbf·ft)
Exhaust muffler bracket bolt		20 N·m (2.0 kgf·m , 14 lbf·ft)
	nut	20 N·m (2.0 kgf·m , 14 lbf·ft)
Sub-frame mounting bolt		12 N·m (1.2 kgf·m , 9 lbf·ft)
	nut	12 N·m (1.2 kgf·m , 9 lbf·ft)

## TROUBLESHOOTING

#### Excessive exhaust noise

- Broken exhaust system
- Exhaust gas leak

#### Poor performance

- Deformed exhaust system
- Exhaust gas leak
- Clogged muffler

## SEAT ('97 – '98)

### REMOVAL

Remove the two mounting socket bolts.  
Slide and remove the seat to the back.

### INSTALLATION

Install the seat by inserting the hook of the seat under the raised lip of the frame cross member. Install the hooks on the rear fender to the tabs of the seat and push the seat forward. Align the bolt holes and tighten the mounting socket bolts securely.

#### CAUTION:

*Be careful not to pinch the wire harness between the seat and the frame.*

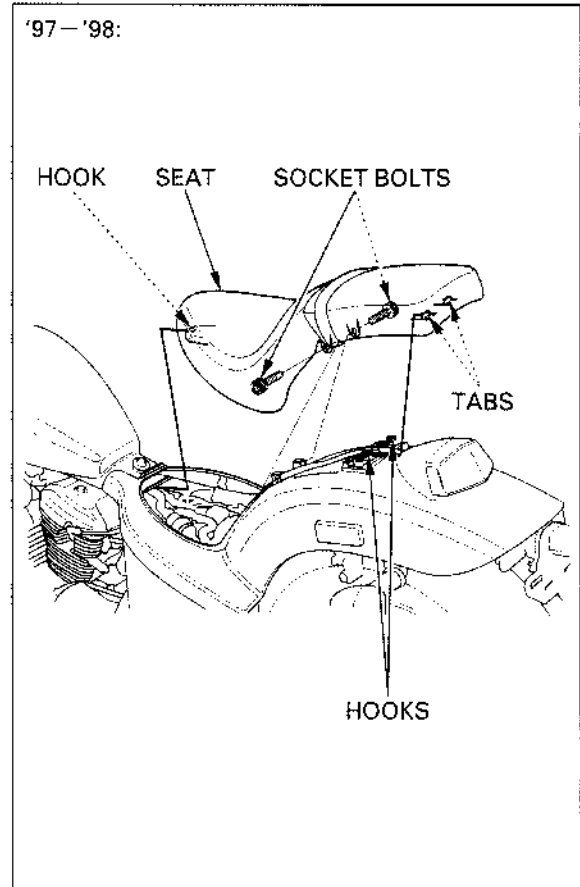

## SEAT (AFTER '98)

### REMOVAL

Remove the two mounting socket bolts.  
Slide and remove the seat toward the back.

### INSTALLATION

Install the seat by aligning the holes in the back of the seat with the bosses on the rear fender. Inserting the hook of the seat under the raised lip of the frame cross member while pushing the seat forward.

Tighten the socket bolts securely.

#### CAUTION:

*Be careful not to pinch the wire harness between the seat and the frame.*

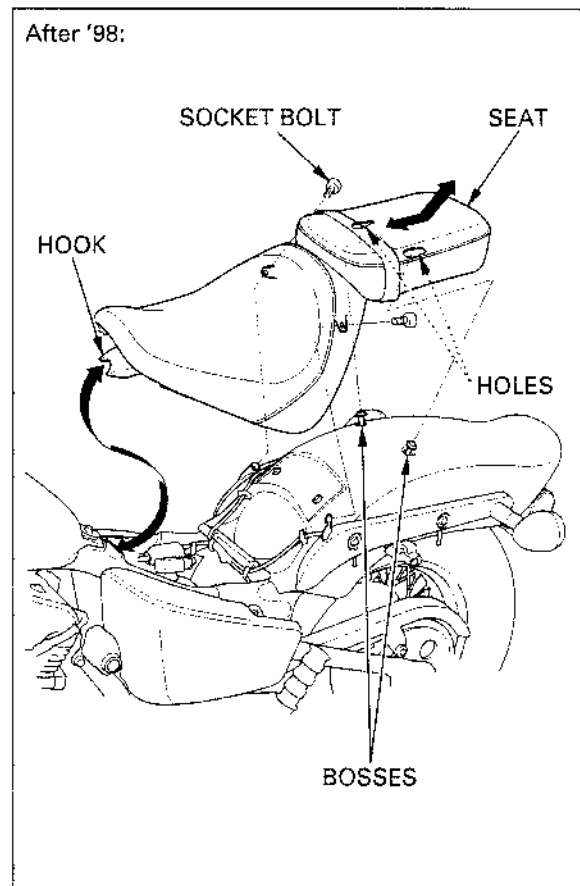

## STEERING COVER

### REMOVAL

#### CAUTION:

*Be careful not to break the steering cover bosses.*

#### NOTE:

Be careful not to dislodge the grommets in the frame.

Remove the mounting screw.  
Remove the joint cover.  
Release the cover bosses from the grommets and steering covers.

### INSTALLATION

#### NOTE:

At installation, align the steering cover bosses on the frame grommets.

Install the steering covers.  
Install and tighten the screw.  
Install the joint cover.

#### NOTE:

Check that the wire harness does not interfere with handlebar rotation.

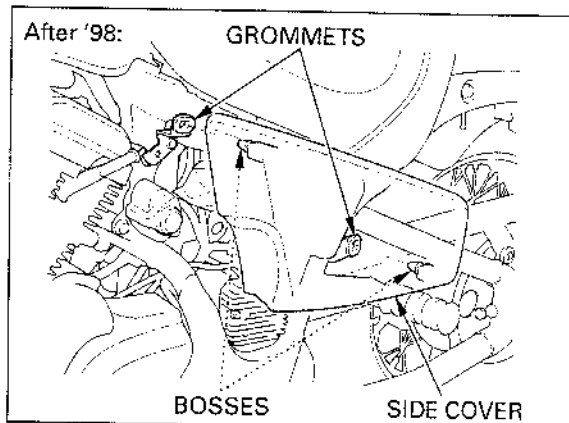
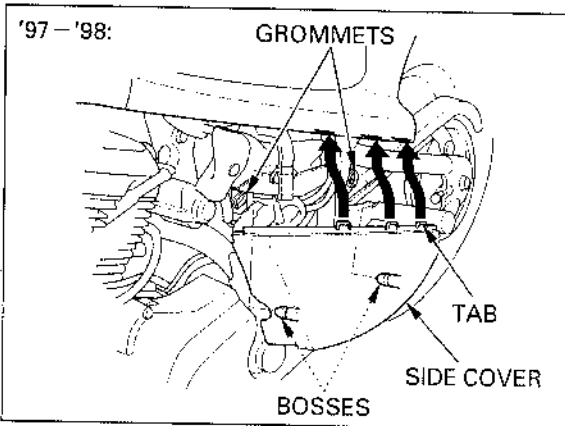
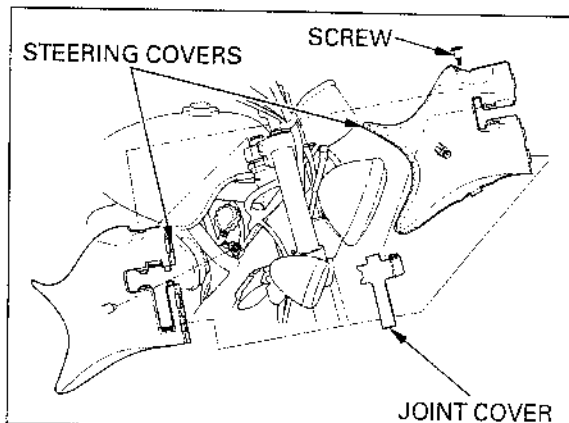
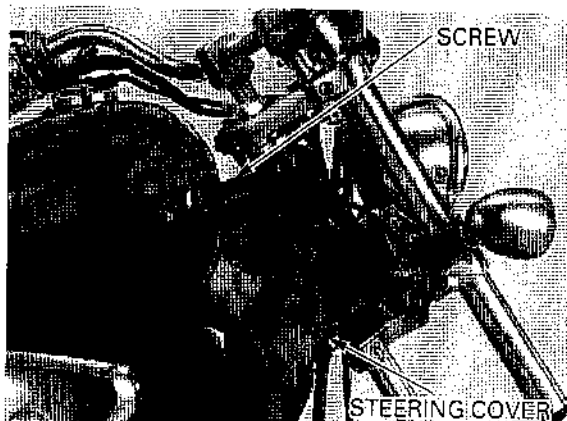

## SIDE COVER

#### CAUTION:

*Be careful not to break the side cover tabs ('97-'98).*

#### NOTE:

Be careful not to dislodge the grommets in the frame.

'97-'98: Release the cover bosses from the grommets and the cover tabs from the rear fender. Remove the side cover.

After '98: Release the cover bosses from the grommets and remove the side cover.

Installation is in the reverse order of removal.

#### NOTE:

At installation, align the cover bosses on the frame grommets.

## FUEL TANK

**▲WARNING**

*Gasoline is extremely flammable and is explosive under certain condition.*

**NOTE:**

Before disconnecting fuel tube, turn the fuel valve "OFF".

### REMOVAL

Remove the seat (page 2-2).

Remove the fuel valve knob mounting screw and fuel valve knob from the fuel valve body.

Remove the fuel tank mounting bolt.

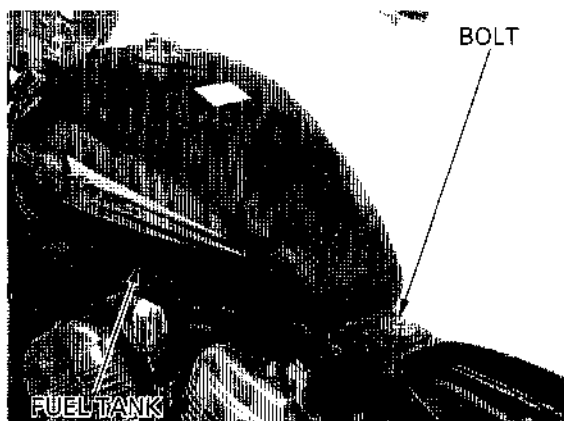

Disconnect the fuel tube.

Remove the fuel tank from the frame.



### DISASSEMBLY/ASSEMBLY

Loosen the fuel valve nut and remove the fuel valve.

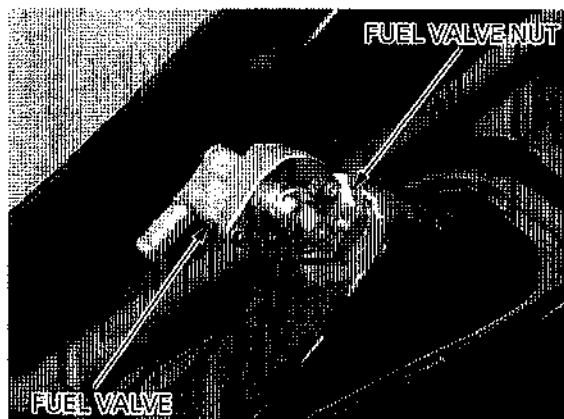

## FRAME/BODY PANELS/EXHAUST SYSTEM

Remove the fuel strainer screen and O-ring.

Check the fuel strainer screen for clogs or damage.

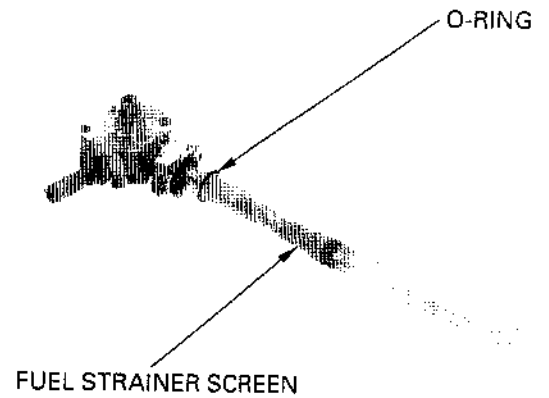

Clean by air or replace if necessary.



Install the new O-ring to the fuel strainer screen.  
Attach the fuel strainer screen to the fuel valve and  
install to the fuel tank.

**NOTE:**

Always replace the O-ring with new ones.

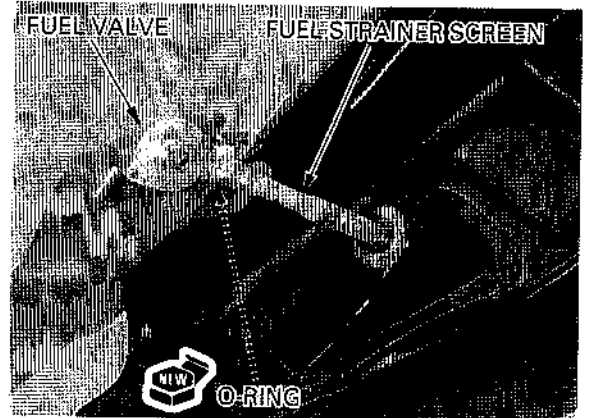

Tighten the fuel valve nut to the specified torque.

**TORQUE:** '97 - '98: 23 N·m (2.3 kgf·m, 17 lbf·ft)  
After '98: 35 N·m (3.6 kgf·m, 26 lbf·ft)

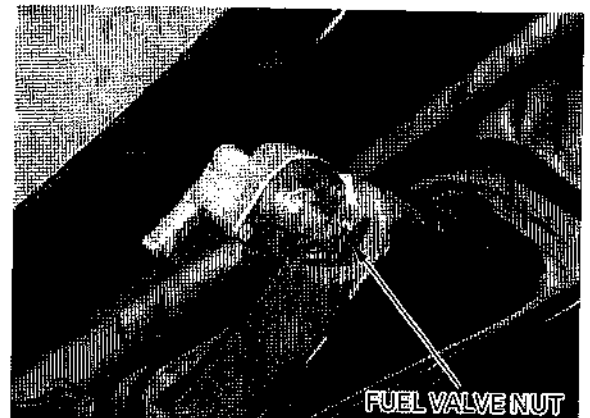

# FRAME/BODY PANELS/EXHAUST SYSTEM

'97 - '98:

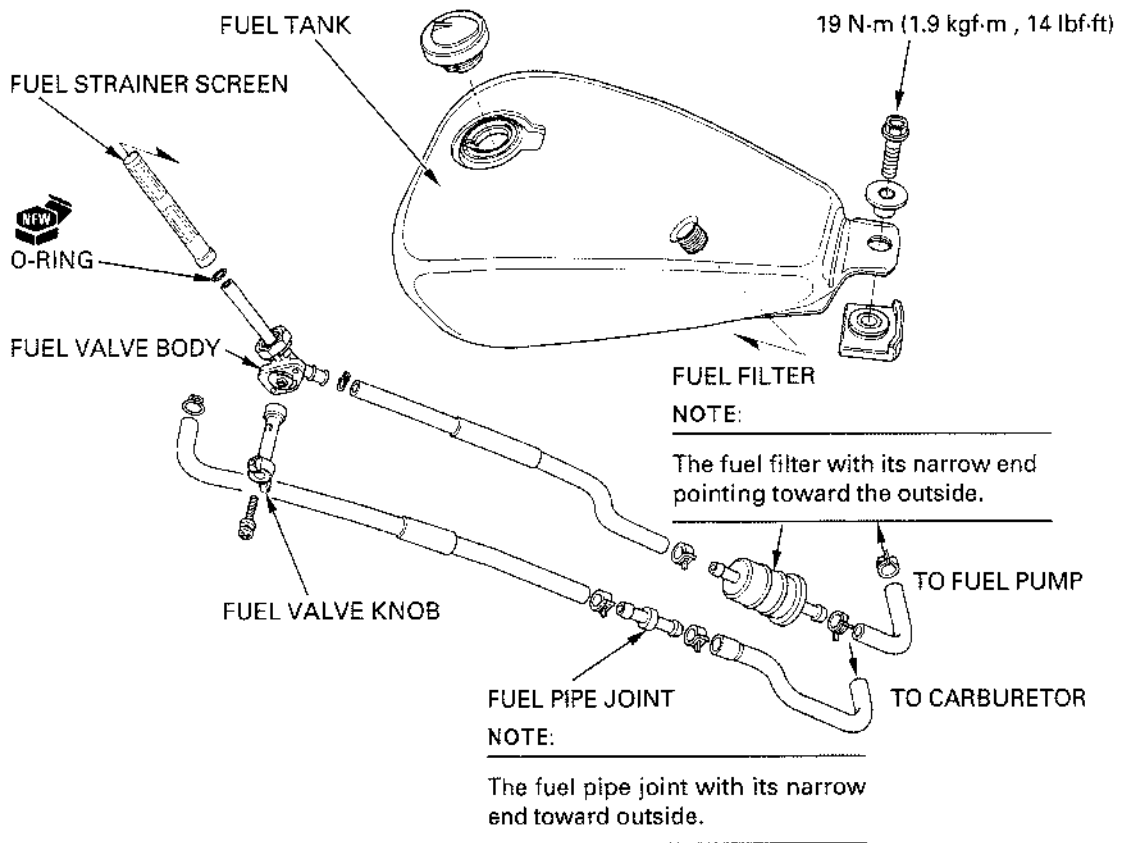

After '98:

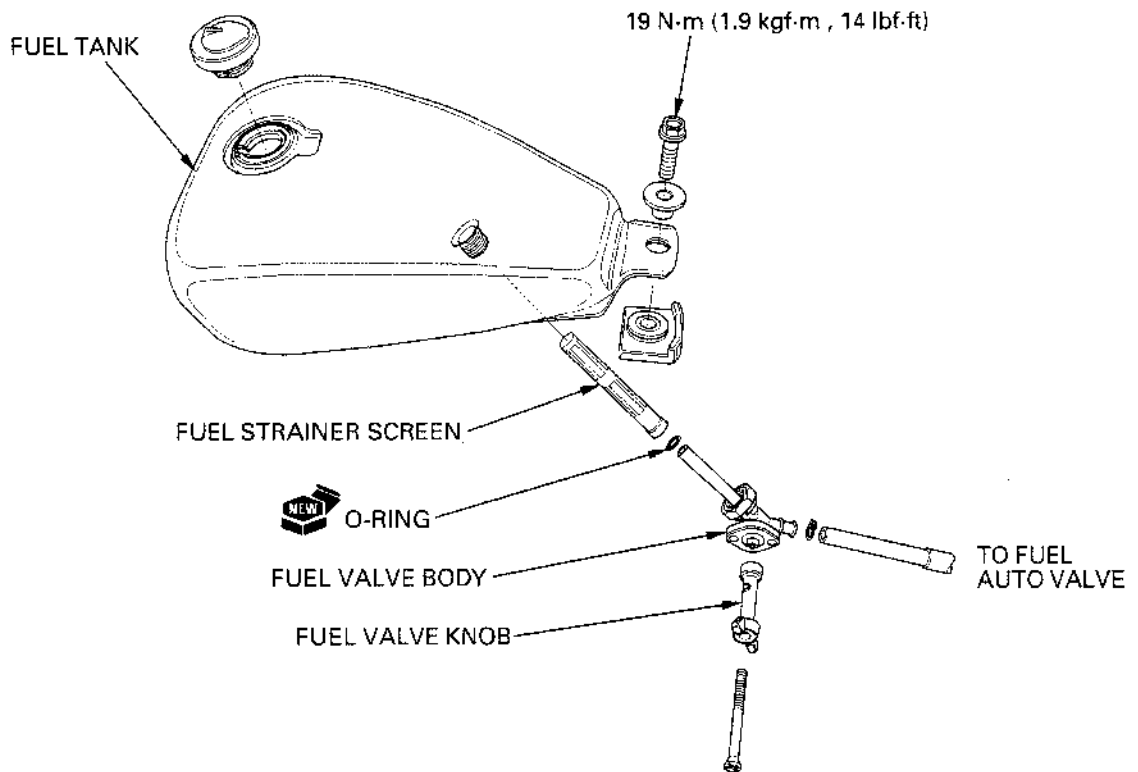

**INSTALLATION**

Connect the fuel tube to the fuel valve.

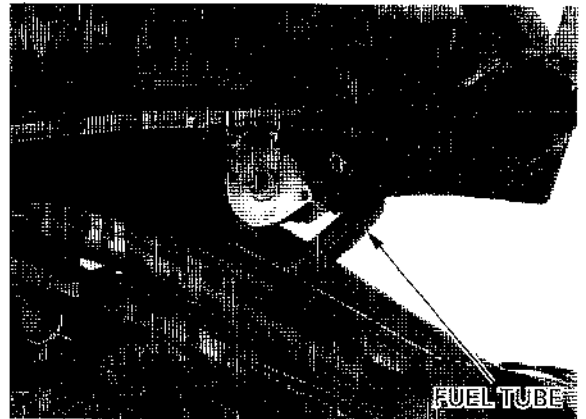

Install the fuel valve knob to the fuel valve.

**NOTE:**

At installation, align the rounded edge on the fuel valve knob with the fuel valve shaft.

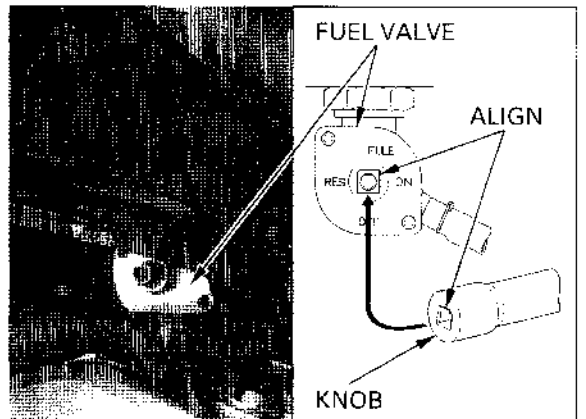

Tighten the screw to the specified torque.

**TORQUE:** 4 N-m (0.4 kgf-m , 2.9 lbf-ft)

**NOTE:**

After installation, turn the fuel valve "ON" and check the fuel line for leakage.

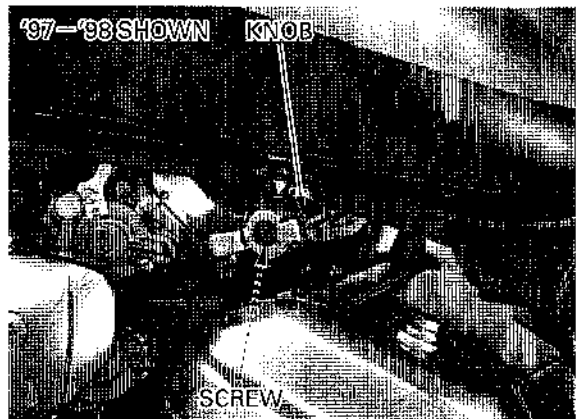

Tighten the fuel tank mounting bolt to the specified torque (page 2-6).

**TORQUE:** 19 N-m (1.9 kgf-m , 14 lbf-ft)

Install the seat (page 2-2).

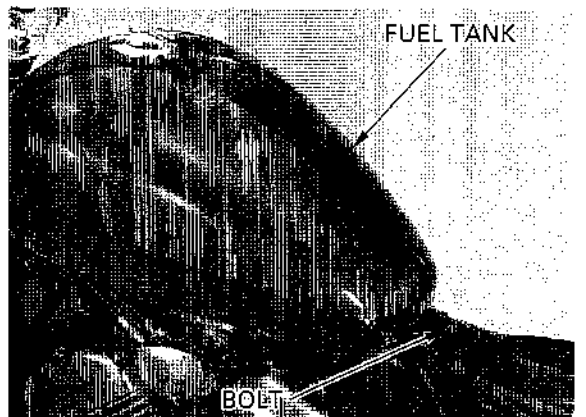

## REAR FENDER/REAR SUB-FRAME

### REMOVAL ('97 — '98)

Remove the seat (page 2-2).  
Remove the right and left side covers (page 2-3).  
Remove the fuel tank (page 2-4).

Remove the rear fender mounting bolts.

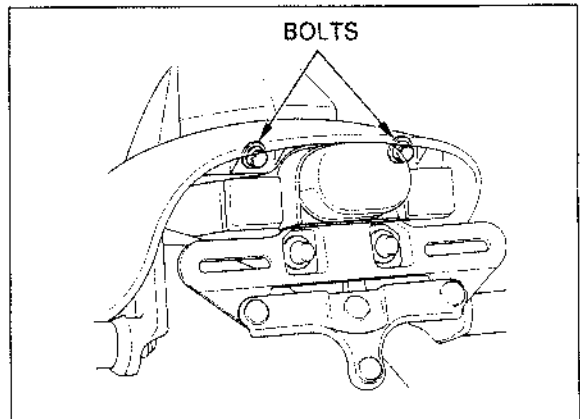

Disconnect the taillight connectors.  
Free the taillight wire harness from the clamps.

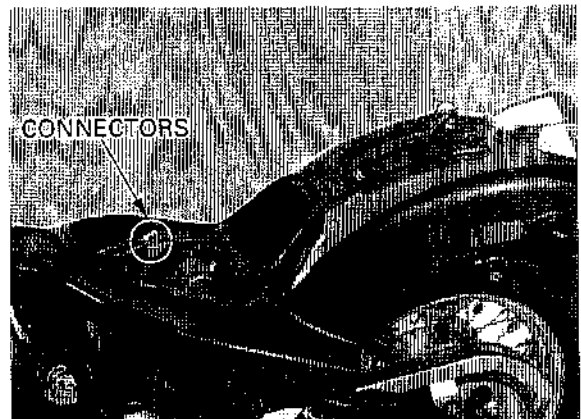

Remove the taillight mounting nuts, washers and taillight.

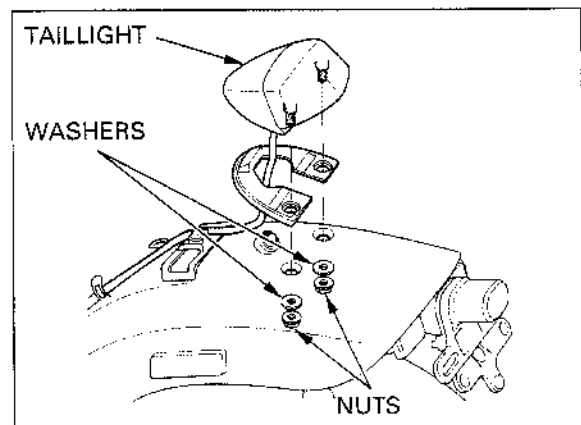

Remove the rear fender mounting bolt and nut.  
Remove the rear fender.

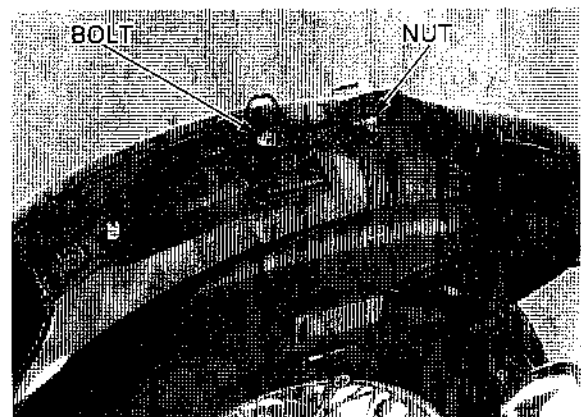



Disconnect the right and left rear turn signal lights and license light connectors.

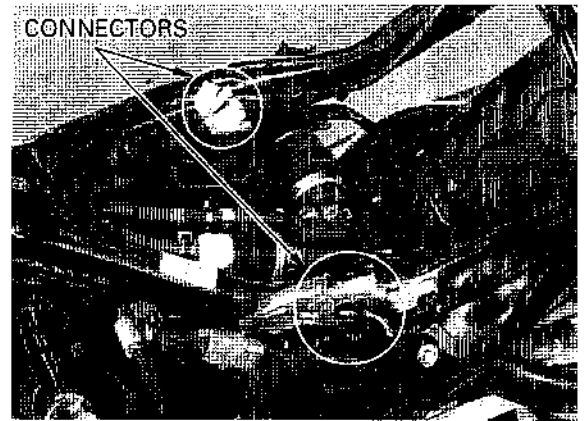

Remove the sub-frame mounting bolts, nuts and sub-frame.

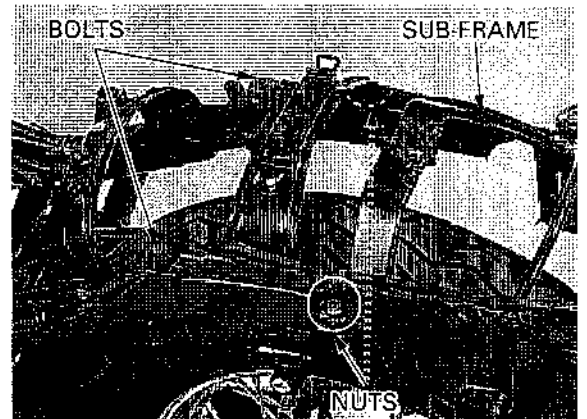

### REMOVAL (After '98)

Remove the seat (page 2-2).  
Disconnect the brake/taillight, license light and rear turn signal lights connectors.

Remove the wires from the clamps.

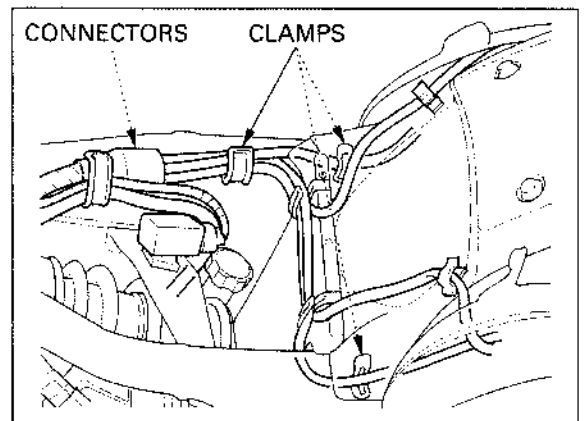

Remove the wires from the clamps.  
Remove the bolts, collars and grab rail.

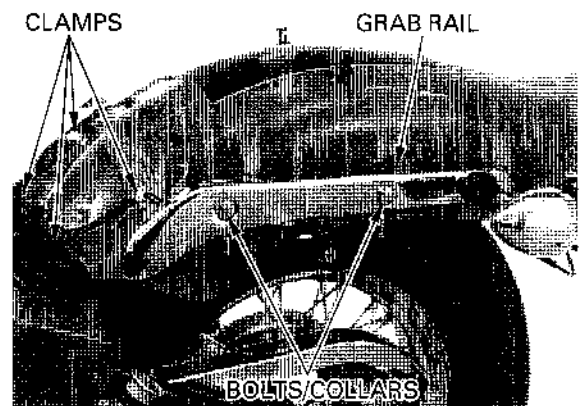

## FRAME/BODY PANELS/EXHAUST SYSTEM

Remove the four bolts, washers, and two collars.  
Remove the rear fender.

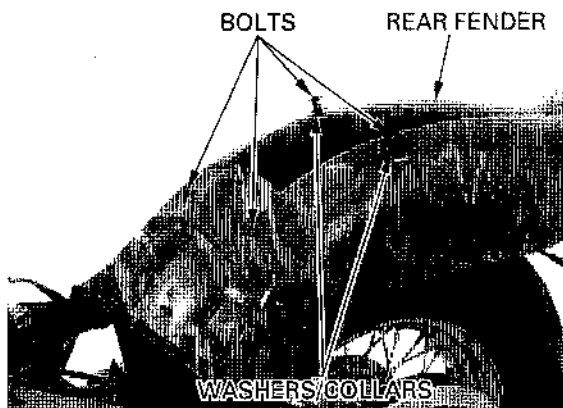

Remove the sub-frame mounting bolts, nuts and  
sub-frame.

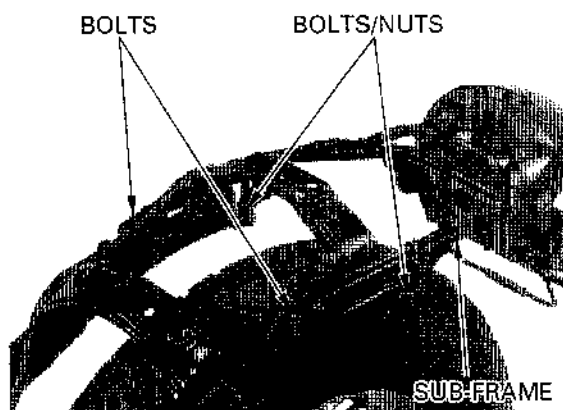

## INSTALLATION ('97 — '98)

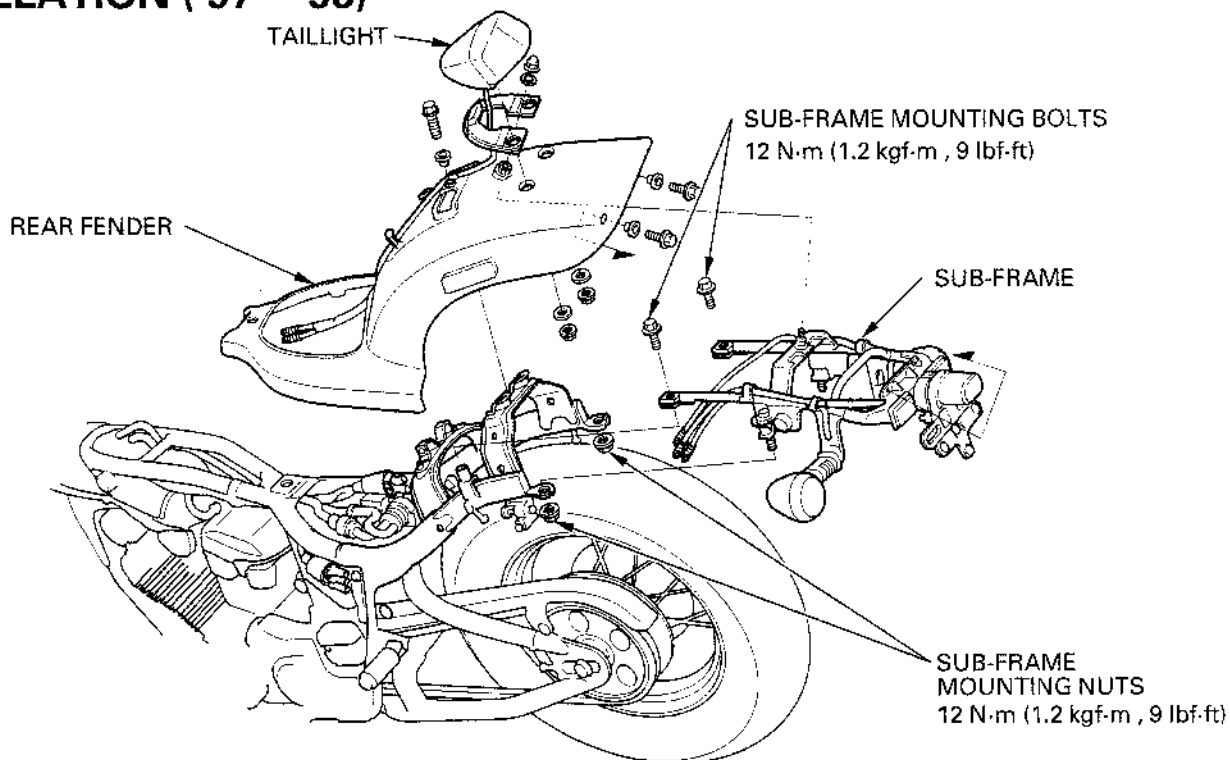

Install the sub-frame, bolts and nuts.  
Tighten the bolts and nuts to the specified torque.

**TORQUE:** 12 N·m (1.2 kgf·m , 9 lbf·ft)

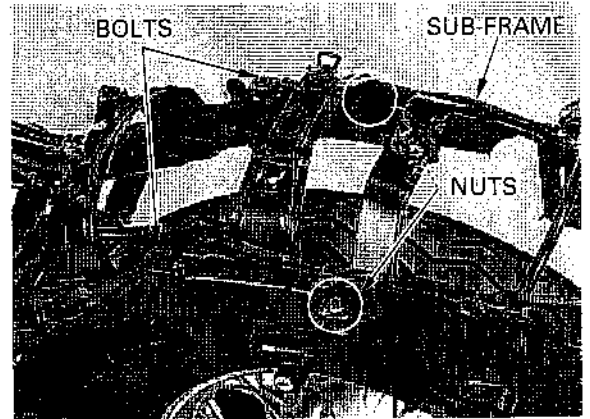

Route the right and left rear turn signal light wires and license light wires.  
Connect the turn signals and license light connectors.

**NOTE:**

Route the wire harness properly (page 1-25).

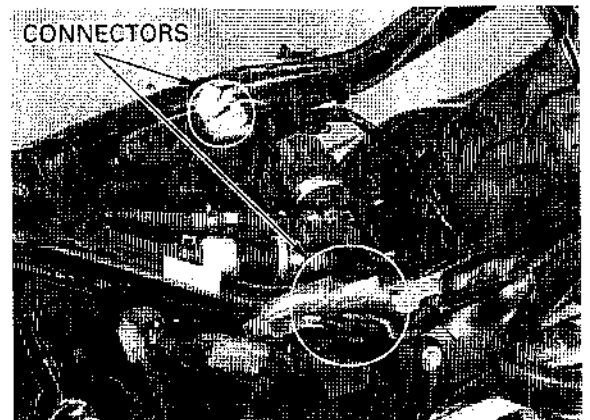

Install the rear fender.  
Install and tighten the mounting bolt and nut securely.

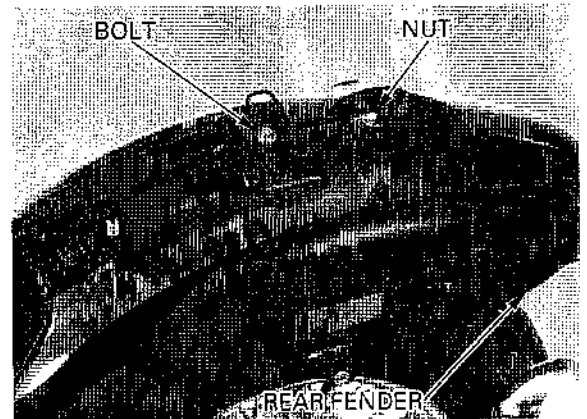

Install the taillight to the rear fender.

**NOTE:**

Install the taillight by aligning the hole on the rear fender with the tab.

Install and tighten the mounting nuts securely.

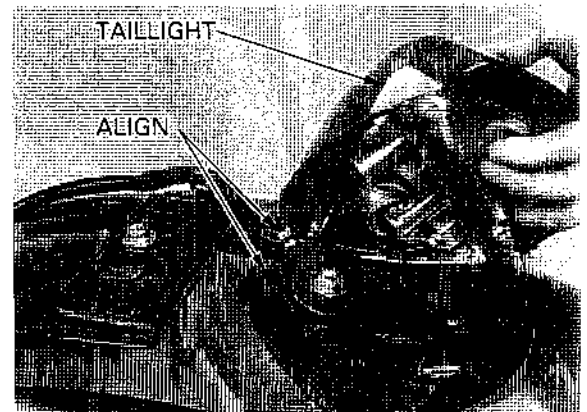

## FRAME/BODY PANELS/EXHAUST SYSTEM

Route the taillight wire harness.  
Connect the taillight connectors.

**NOTE:**

Route the wire harness securely (page 1-30).

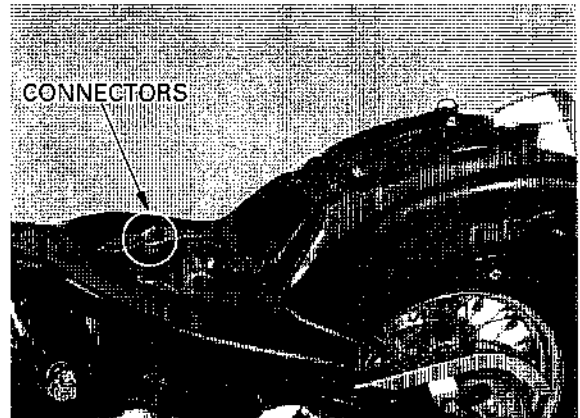

Install and tighten the rear fender mounting bolts securely.

Install the fuel tank (page 2-7).  
Install the right and left side covers (page 2-3).  
Install the seat (page 2-2).

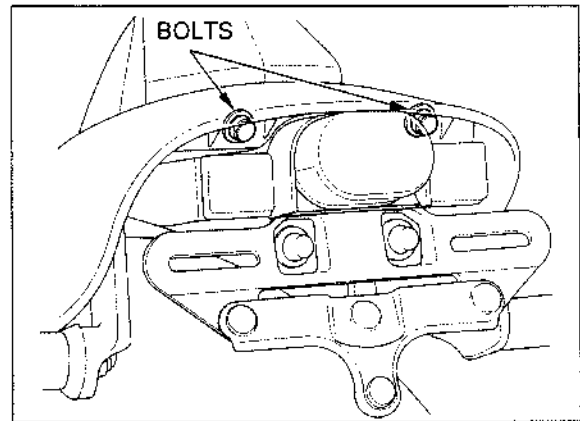

## INSTALLATION (After '98)

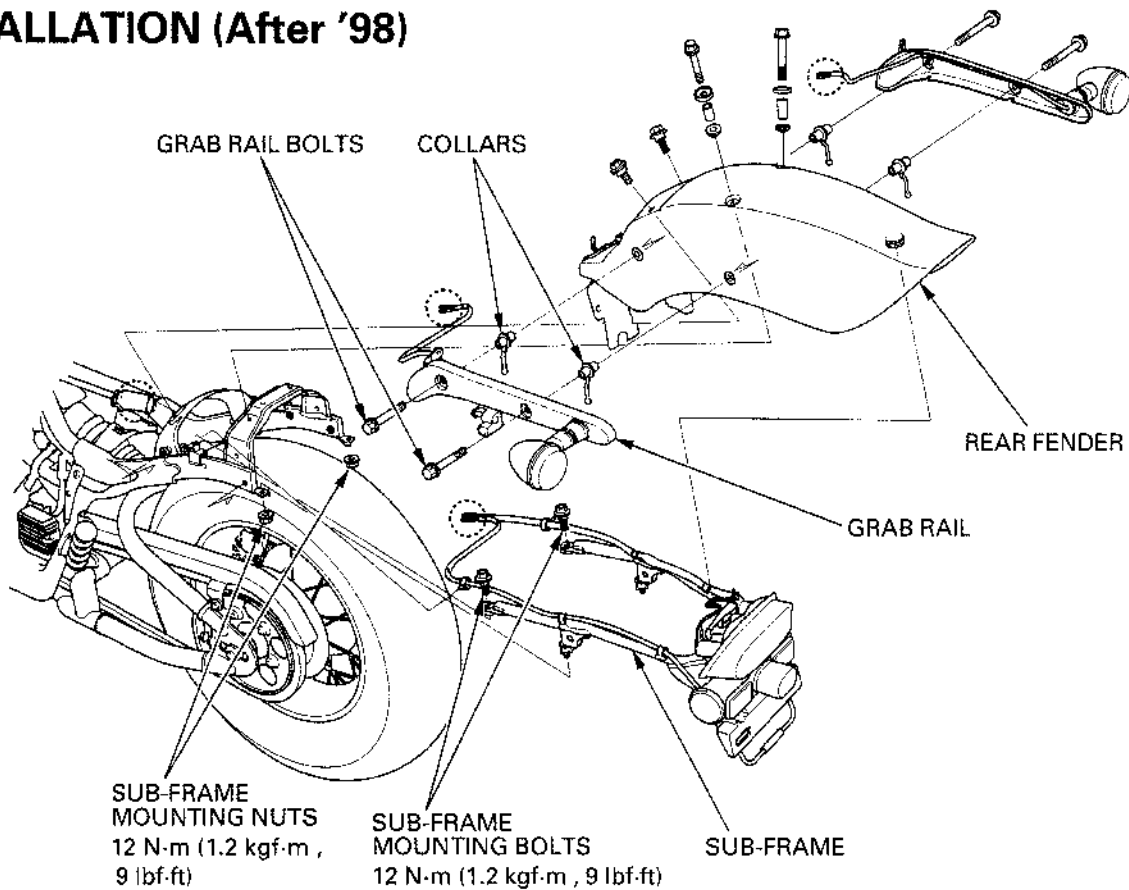

## FRAME/BODY PANELS/EXHAUST SYSTEM

Install the sub-frame, bolts and nuts.  
Tighten the bolts and nuts to the specified torque.

**TORQUE:** 12 N·m (1.2 kgf·m, 9 lbf·ft)

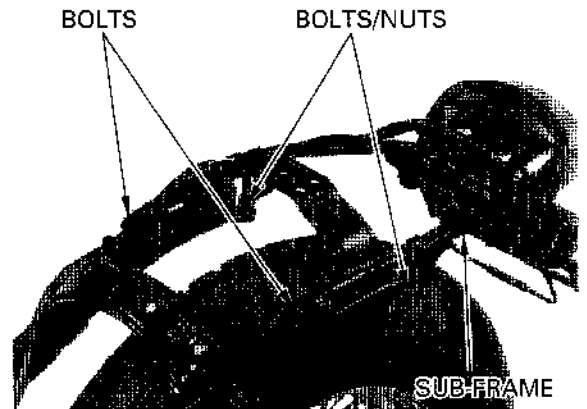

Install the boss of the rear fender to the hook on the sub-frame.

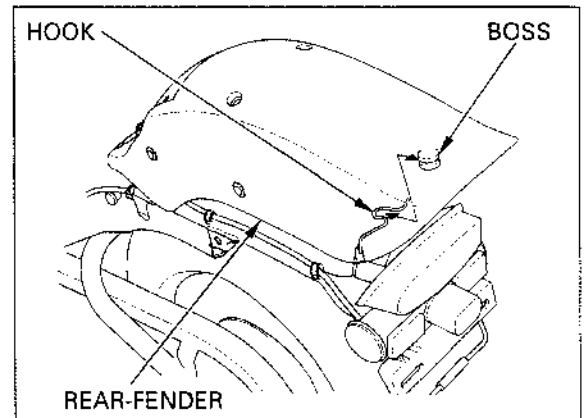

Install the washers and collars to the rear fender.  
Install and tighten the four bolts securely.

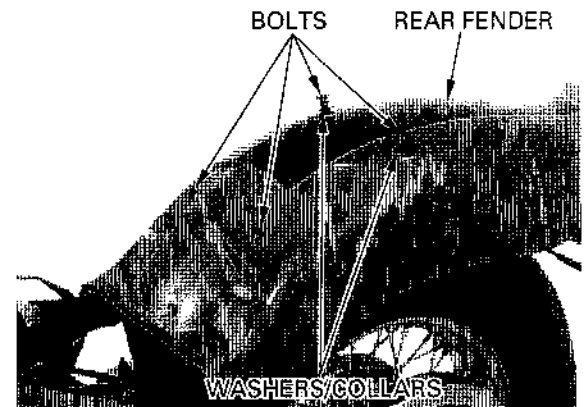

Install the collars and grab rail.  
Install and tighten the bolts.  
Install the wires in the clamps.

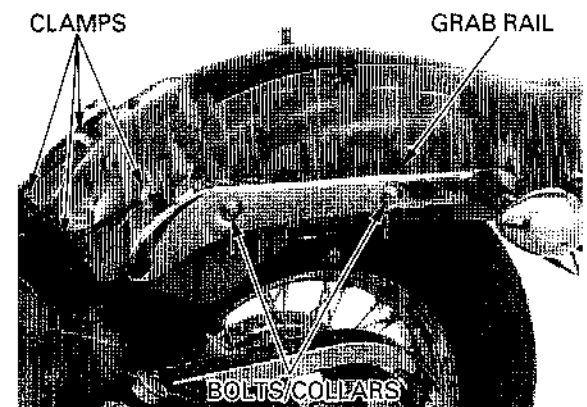

## FRAME/BODY PANELS/EXHAUST SYSTEM

Install the wires in the clamps.  
Connect the brake/taillight, license light and rear turn signal lights connectors.

Install the seat (page 2-2).

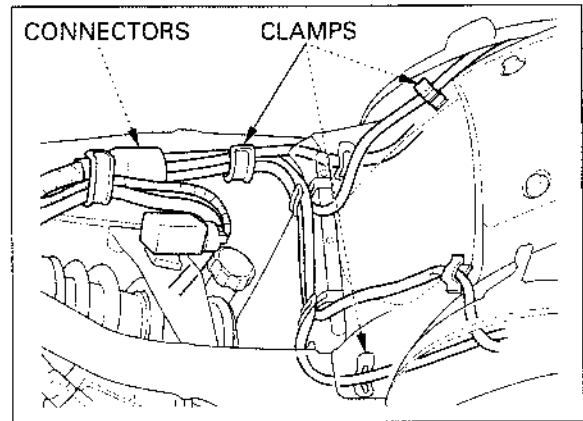

## EXHAUST PIPE/MUFFLER

### ▲WARNING

*Do not service the exhaust system while it is hot.*

### CAUTION:

*When removing/installing the exhaust pipe/muffler, be sure to loosen/tighten the exhaust system fasteners in the specified order as follows.*

### REMOVAL

- Remove the exhaust pipe joint nuts.
- Remove the muffler mounting bolt, washer and nut.
- Remove the exhaust pipe/muffler assembly.

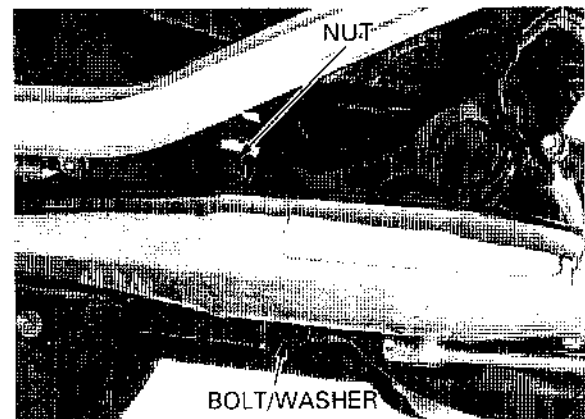
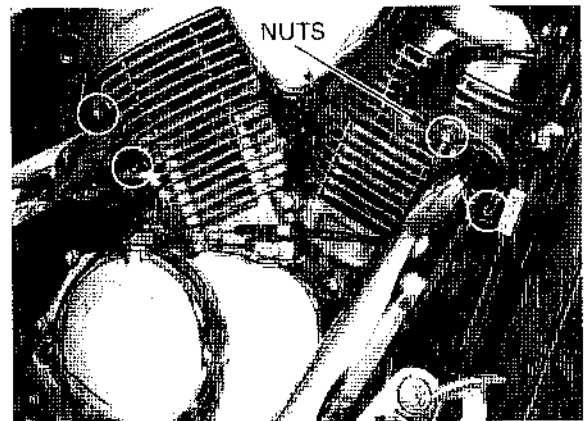

- Remove the front exhaust pipe joint and collar.
- Remove the front and rear gaskets.

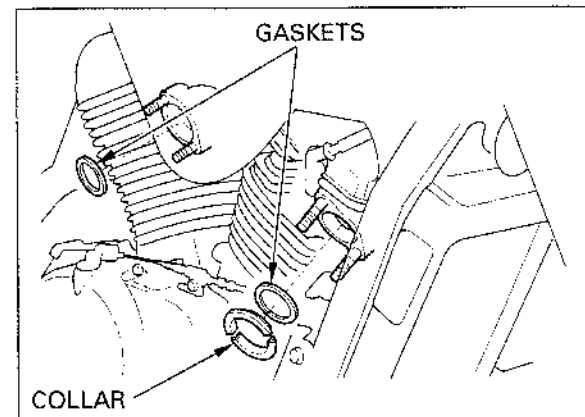

Remove the bolts and exhaust covers.

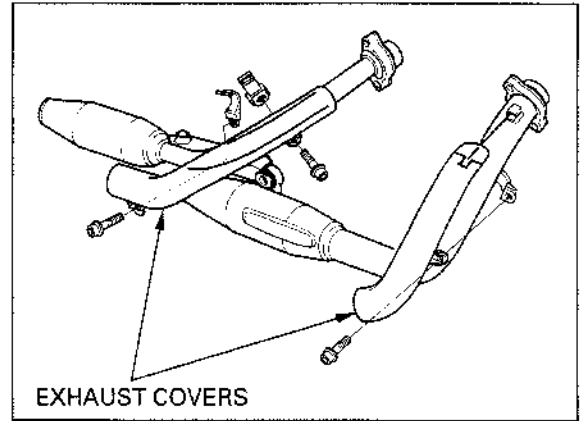

## INSTALLATION

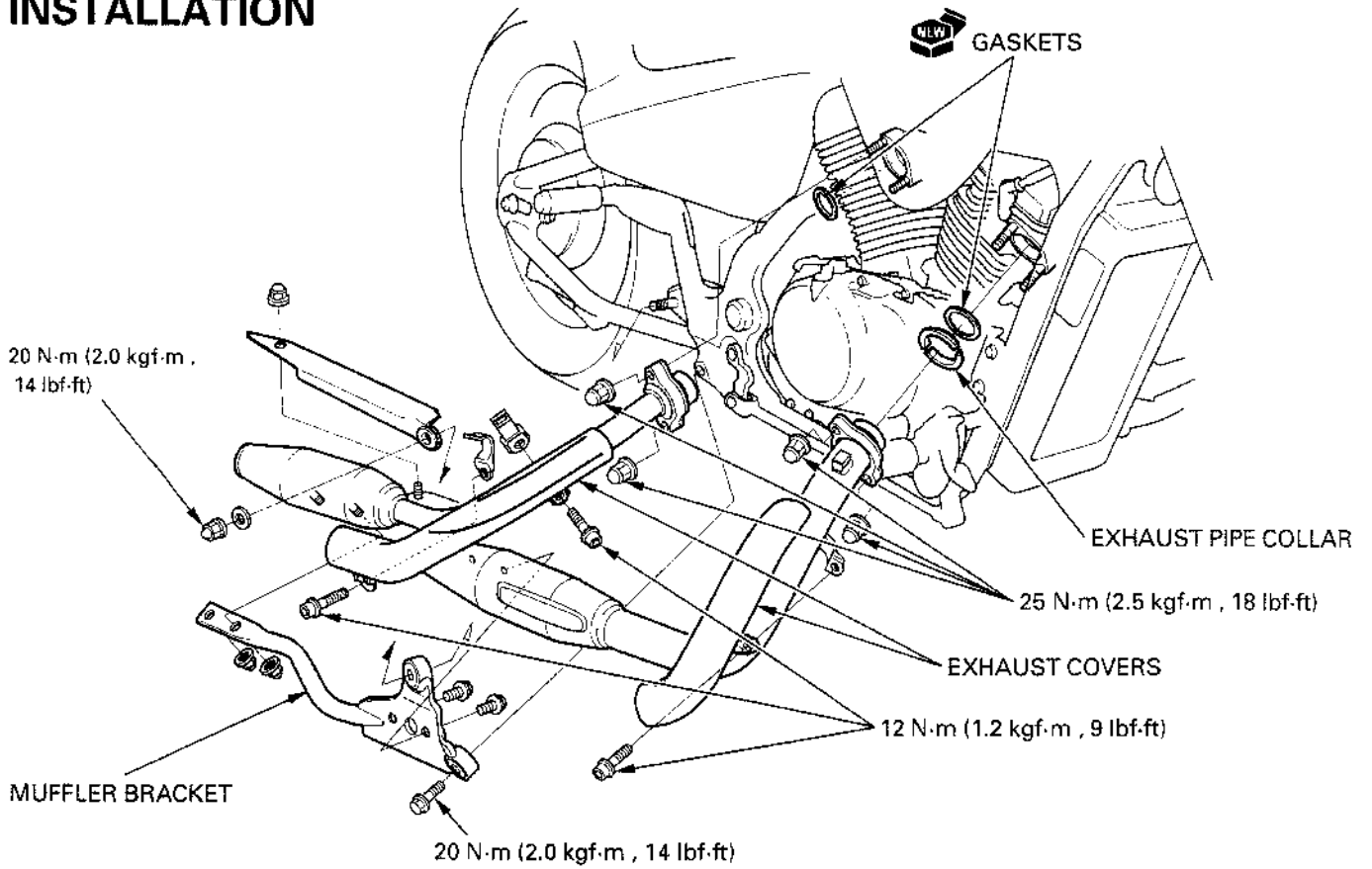

Install the exhaust covers and bolts.  
Tighten the bolts to the specified torque.

**TORQUE:** 12 N·m (1.2 kgf·m , 9 lbf·ft)

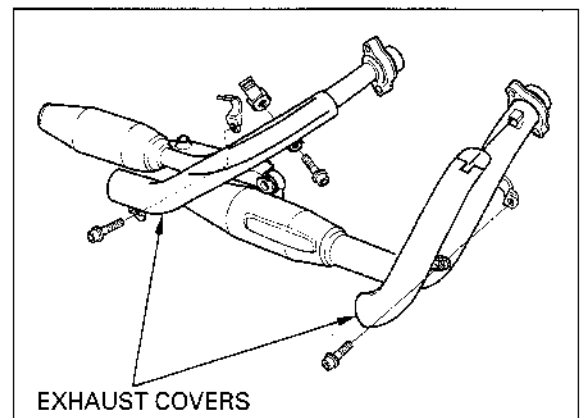

## FRAME/BODY PANELS/EXHAUST SYSTEM

Install the new gaskets.

**NOTE:**

Install the gaskets to the correct position.

- Front side: Large O.D.
- Rear side: Small O.D.

Install the front exhaust pipe collar.

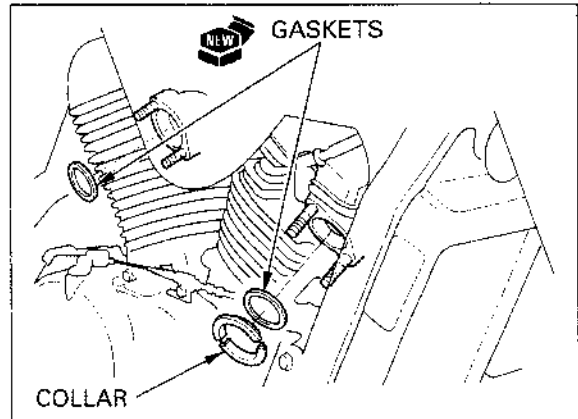

Install the muffler assembly.

Temporarily install all bolts, washer and nuts.

**NOTE:**

Do not tighten the bolts and nuts yet.

Tighten the muffler mounting bolt and nut to the specified torque.

**TORQUE:** 20 N·m (2.0 kgf·m , 14 lbf·ft)

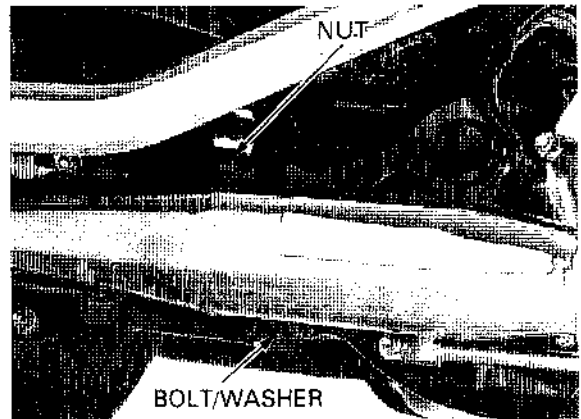

Tighten the exhaust pipe joint nuts to the specified torque.

**TORQUE:** 25 N·m (2.5 kgf·m , 18 lbf·ft)

**NOTE:**

Always inspect the exhaust system for leaks after installation.

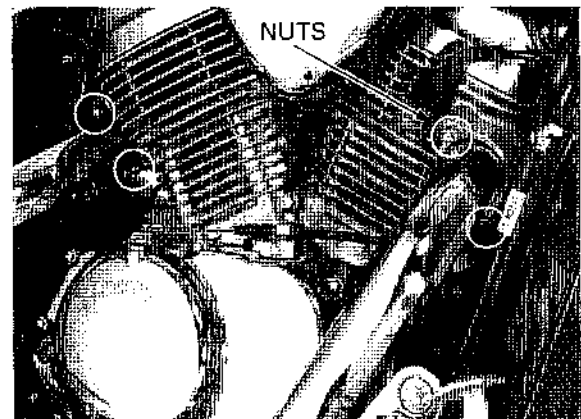



# 3. MAINTENANCE

SERVICE INFORMATION	3-1	DRIVE CHAIN	3-20
MAINTENANCE SCHEDULE	3-3	BRAKE FLUID	3-24
FUEL LINE	3-4	BRAKE SHOE/PAD WEAR	3-25
THROTTLE OPERATION	3-4	BRAKE SYSTEM	3-26
CARBURETOR CHOKE	3-6	BRAKE LIGHT SWITCH	3-27
AIR CLEANER	3-8	HEADLIGHT AIM	3-28
CRANKCASE BREATHER	3-9	CLUTCH SYSTEM	3-28
SPARK PLUG	3-9	SIDE STAND	3-29
VALVE CLEARANCE	3-11	SUSPENSION	3-29
ENGINE OIL/OIL FILTER	3-14	NUTS, BOLTS, FASTENERS	3-30
CARBURETOR SYNCHRONIZATION ('97-'98)	3-17	WHEELS/TIRES	3-30
ENGINE IDLE SPEED	3-18	STEERING HEAD BEARINGS	3-31
RADIATOR COOLANT	3-19		
COOLING SYSTEM	3-19		
EVAPORATIVE EMISSION CONTROL SYSTEM (CALIFORNIA TYPE ONLY)	3-20		

## SERVICE INFORMATION

### GENERAL

#### ▲WARNING

- Gasoline is extremely flammable and is explosive under certain conditions. Work in a well ventilated area. Smoking or allowing flames or sparks in the work area or where the gasoline is stored can cause a fire or explosion.
- When the engine must be running to do some work, make sure the area is well-ventilated. Never run the engine in an enclosed area. The exhaust contains poisonous carbon monoxide gas that may cause loss of consciousness and lead to death. Run the engine in an open area or with an exhaust evacuation system in an enclosed area.

- Place the motorcycle on a level ground before starting any work.

### SPECIFICATIONS

ITEM		SPECIFICATIONS	
Throttle grip free play		2 – 6 mm (1/12 – 1/4)	
Spark plug	Standard	DPR8EA-9 (NGK)	X24EPR-U9 (DENSO)
	For cold climate (below 5 °C/41 °F)	DPR7EA-9 (NGK)	X22EPR-U9 (DENSO)
	For extend high speed riding	DPR9EA-9 (NGK)	X27EPR-U9 (DENSO)
Spark plug gap		0.80 – 0.90 mm (0.031 – 0.035 in)	
Valve clearance	IN	0.15 mm (0.006 in)	
	EX	0.20 mm (0.008 in)	

## MAINTENANCE

ITEM		SPECIFICATIONS	
Engine oil capacity	At draining	2.1 ℓ (2.2 US qt, 1.8 Imp qt)	
	At disassembly	2.8 ℓ (3.0 US qt, 2.5 Imp qt)	
	At oil filter change	2.25 ℓ (2.38 US qt, 1.98 Imp qt)	
Recommended engine oil		HONDA GN4 or HP4 4-stroke oil or equivalent motor oil API service classification SF or SG Viscosity: SAE 10W-40	
Engine idle speed		1,200 ± 100 rpm	
Drive chain slack		20-30 mm (3/4 - 1-1/4 in)	
Standard links		120L	
Recommended brake fluid		Honda DOT 4 Brake Fluid	
Clutch lever free play		10-20 mm (3/8 - 3/4 in)	
Tire size	Front	100/90-19 57S	
	Rear	170/80-15 M/C 77S	
Tire brand	Front	'97-'98	BRIDGESTONE L309 / DUNLOP F24
		After '98	DUNLOP F24
	Rear	'97-'98	BRIDGESTONE G546 / DUNLOP K555
		After '98	DUNLOP D404
Cold tire pressure	Up to 90 kg (200 lb) load	Front	200 kPa (2.00 kgf/cm <sup>2</sup> , 29 psi)
		Rear	200 kPa (2.00 kgf/cm <sup>2</sup> , 29 psi)
	Up to maximum weight capacity	Front	200 kPa (2.00 kgf/cm <sup>2</sup> , 29 psi)
		Rear	250 kPa (2.50 kgf/cm <sup>2</sup> , 36 psi)
Minimum tire tread depth	Front	1.5 mm (0.06 in)	
	Rear	2.0 mm (0.08 in)	

## TORQUE VALUES

Spark plug	14 N·m (1.4 kgf·m, 10 lbf·ft)	
Valve adjust cover	12 N·m (1.2 kgf·m, 9 lbf·ft)	
Valve adjusting screw lock nut	23 N·m (2.3 kgf·m, 17 lbf·ft)	Apply oil to the threads and seating surface
Timing hole cap	15 N·m (1.5 kgf·m, 11 lbf·ft)	Apply molybdenum disulfide oil to the threads
Crankshaft hole cap	15 N·m (1.5 kgf·m, 11 lbf·ft)	Apply molybdenum disulfide oil to the threads
Oil drain bolt	'97-'98: 34 N·m (3.5 kgf·m, 25 lbf·ft) After '98: 30 N·m (3.1 kgf·m, 22 lbf·ft)	
Oil filter cartridge	10 N·m (1.0 kgf·m, 7 lbf·ft)	Apply a engine oil to the threads.
Vacuum plug ('97-'98)	3 N·m (0.33 kgf·m, 2.4 lbf·ft)	
Rear axle nut	88 N·m (9.0 kgf·m, 65 lbf·ft)	
Spokes	4 N·m (0.4 kgf·m, 2.9 lbf·ft)	

## TOOLS

Valve adjusting wrench	07908 - KE90000 or 07908 - KE90100 (U.S.A only)
Vacuum gauge	07404 - 0030000 or 07LMJ - 001000A (U.S.A only)
Oil filter wrench	07HAA - PJ70100
Drive chain tool set	07HMH - MR10103 or 07HMH - MR1010A (U.S.A. only)
Spoke wrench	07JMA - MR60100

# MAINTENANCE SCHEDULE

Perform the Pre-ride inspection in the Owner's Manual at each scheduled maintenance period.

I: Inspect and Clean, Adjust, Lubricate or Replace if necessary. C: Clean. R: Replace. A: Adjust. L: Lubricate.

The following items require some mechanical knowledge. Certain items (particularly those marked \* and \*\*) may require more technical information and tools. Consult your authorized HONDA dealer.

ITEMS	FREQUENCY	NOTE	ODOMETER READING (NOTE 1)								REFER TO PAGE		
			× 1,000 mi	0.6	4	8	12	16	20	24			
			× 1,000 km	1	6	12	18	24	30	36			
EMISSION RELATED ITEMS	* FUEL LINE					I			I				3-4
	* THROTTLE OPERATION					I			I				3-4
	* CARBURETOR CHOKE					I			I				3-6
	AIR CLEANER	NOTE 2						R					3-8
	CRANKCASE BREATHER	NOTE 3			C	C	C	C	C	C	C	C	3-9
	SPARK PLUG				R	R	R	R	R	R	R	R	3-9
	* VALVE CLEARANCE			I		I		I		I			3-11
	ENGINE OIL			R		R		R		R			3-14
	ENGINE OIL FILTER			R		R		R		R			3-14
	* CARBURETOR SYNCHRONIZATION	'97-'98			I		I		I		I		3-17
	* ENGINE IDLE SPEED				I	I	I	I	I	I	I	I	3-18
	RADIATOR COOLANT	NOTE 5					I		I		R		3-19
	* COOLING SYSTEM						I		I		I		3-19
	* EVAPORATIVE EMISSION CONTROL SYSTEM	NOTE 4						I				I	3-20
NON-EMISSION RELATED ITEMS	DRIVE CHAIN		EVERY 500 mi (800 km) L								3-20		
	BRAKE FLUID	NOTE 5											3-24
	BRAKE SHOES/PAD WEAR												3-25
	BRAKE SYSTEM												3-26
	* BRAKE LIGHT SWITCH												3-27
	* HEADLIGHT AIM												3-28
	CLUTCH SYSTEM												3-28
	SIDE STAND												3-29
	SUSPENSION												3-29
	* NUTS, BOLTS, FASTENERS												3-30
	** WHEELS/TIRES												3-30
** STEERING HEAD BEARINGS												3-31	

\* Should be serviced by an authorized HONDA dealer, unless the owner has proper tools and service data and is mechanically qualified.

\*\* In the interest of safety, we recommend these items be serviced only by an authorized HONDA dealer.

- NOTES:
- At higher odometer reading, repeat at the frequency interval established here.
  - Service more frequently when riding in unusually wet or dusty areas.
  - Service more frequently when riding in rain or at full throttle.
  - California type only.
  - Replace every 2 years, or at indicated odometer interval, whichever comes first. Replacement requires mechanical skill.

## FUEL LINE

**▲WARNING**

*Gasoline is extremely flammable and is explosive under certain conditions. KEEP OUT OF REACH OF CHILDREN.*

Remove the seat (page 2-2) and fuel tank (page 2-4).

Check the fuel lines for deterioration, damage or leakage.

Replace the fuel lines if necessary.

Also check the fuel valve vacuum tube for damage and replace the vacuum tube if necessary ('97 - '98).

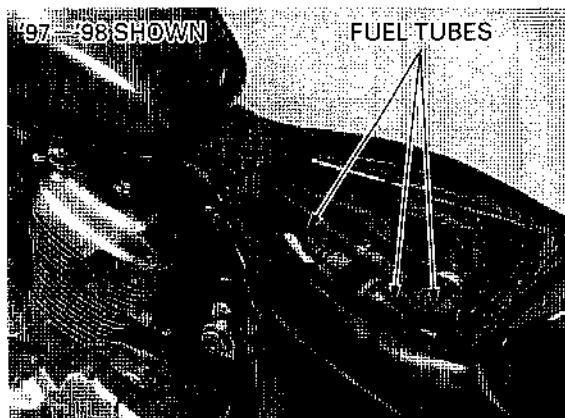

### FUEL FILTER ('97 - '98)

Pull the fuel filter out, clip the inlet line closed and remove the filter.

Replace the fuel filter with new one, if necessary (page 5-34).

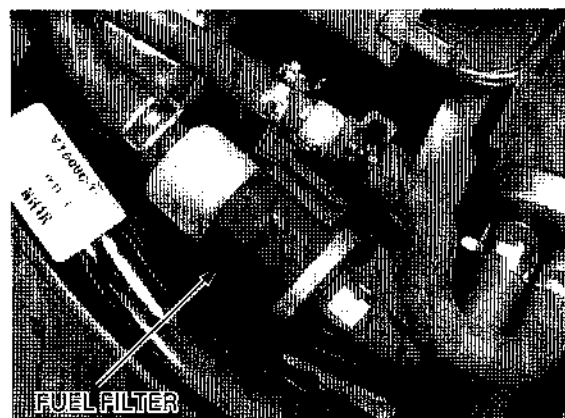

## THROTTLE OPERATION

Check for any deterioration or damage to the throttle cables.

Check the throttle grip for smooth operation. Check that the throttle grip returns from the full open to the full closed position smoothly and automatically in all steering positions.

If the throttle grip does not return properly, lubricate the throttle cable, overhaul and lubricate the throttle grip housing.

For cable lubrication: Disconnect the throttle cables at their upper ends (page 13-7). Thoroughly lubricate the cables and their pivot points with a commercially available cable lubricant or a light weight oil.

If the throttle grip still does not return properly, replace the throttle cables.

**▲WARNING**

*Reusing a damaged or abnormally bent or kinked throttle cable can prevent proper throttle side operation and may lead to a loss of throttle control while riding.*

With the engine idling, turn the handlebar all the way to the right and left to ensure that idle speed does not change.

If idle speed increases, check the throttle grip free play and the throttle cable connection.

Measure the throttle grip free play at the throttle grip flange.

**FREE PLAY:** 2–6 mm (1/12– 1/4 in)

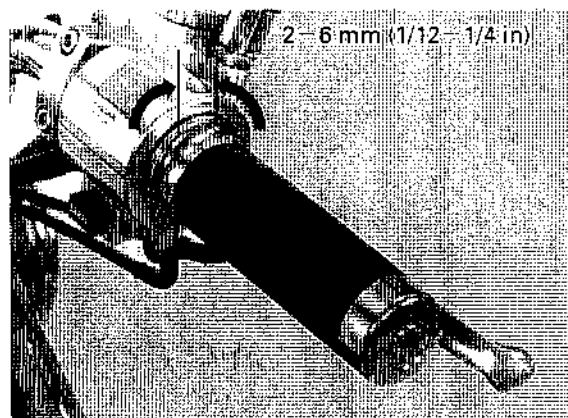

Throttle grip free play can be adjusted at either end of the throttle cable. Minor adjustments are made with the upper adjuster.

Loosen the lock nut and turn the adjuster to obtain the free play.

After the adjustment, tighten the lock nut securely and reposition the boot ('97–'98) properly.

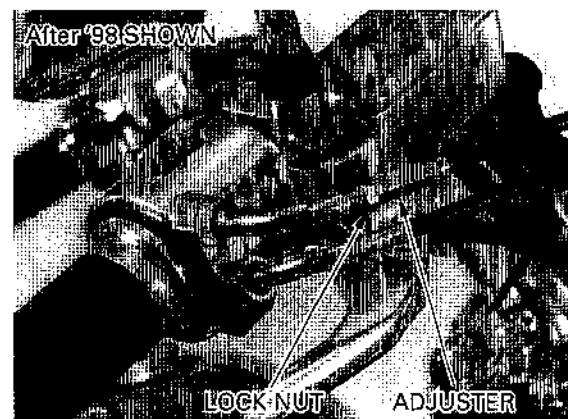
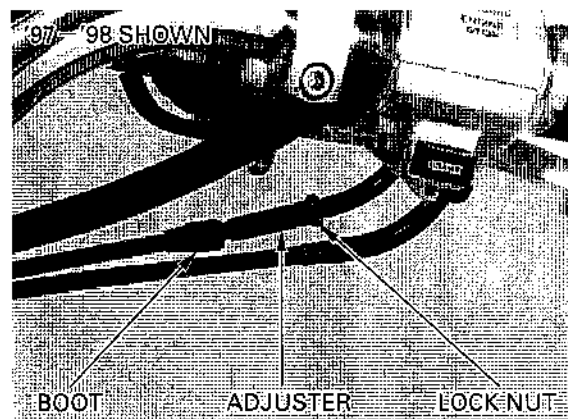

## MAINTENANCE

Remove the fuel tank (After '98: page 2-4).  
Major adjustments are made with the lower adjuster.

Loosen the lock nuts and turn the adjusters to obtain the free play.  
Tighten the lock nuts after the adjustment has been made.

Recheck the free play.



## CARBURETOR CHOKE

### STARTING ENRICHMENT (SE) VALVE

The choke system uses a fuel enriching circuit controlled by an SE valve. The SE valve opens the enriching circuit via a cable when the choke knob on the right side of the carburetor is pulled.



Check for smooth operation of the choke knob.  
Check for any deterioration or damage to the choke cable.

If the operation is not smooth, lubricate the choke cable and choke knob sliding surface with a commercially available cable lubricant or a light weight oil.

To adjust the friction, pull the rubber cover away and turn the adjuster.

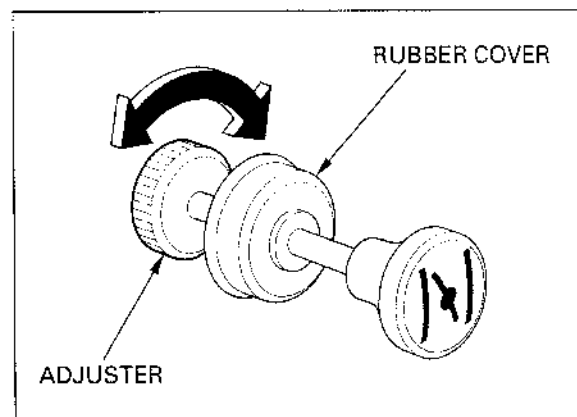

Starting enrichment system operation can be checked by the way the engine starts and runs:

- Difficulty in starting before the engine is warm up (easy once it is warmed up): SE valve is not completely opened.
- Idle speed is erratic even after warm-up (imperfect combustion): SE valve is not completely closed.

When the above symptoms occur, inspect the SE valve using the following procedure.

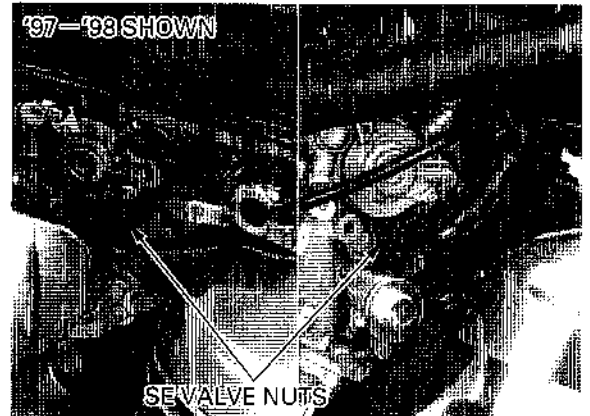

**NOTE:**

Remove the fuel tank (page 2-4) when inspecting the SE valve of AFTER '98 models.

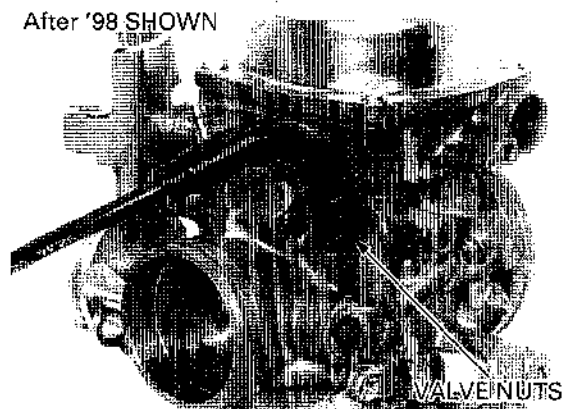

Loosen the SE valve nut(s) and remove (them) from the carburetor(s) ('97-'98).

Pull the choke knob all the way out to fully open position and recheck for smooth operation of the choke knob.

There should be no free play.

Check valve seat on the choke valve for damage. Reinstall the choke valve in the reverse order of removal.



After '98 SHOWN

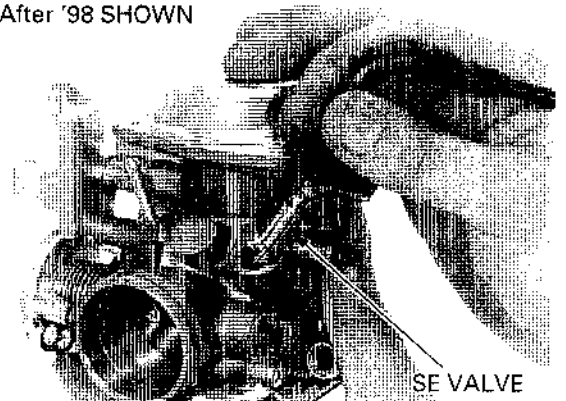

## AIR CLEANER

**NOTE:**

- The viscous paper element type air cleaner cannot be cleaned because the element contains a dust adhesive.
- If the motorcycle is used in wet or dusty areas, more frequent inspections are required.

'97-'98: Remove the air cleaner housing cover bolt and cover.

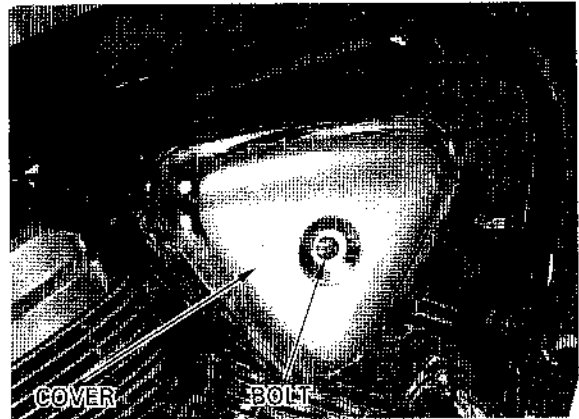

Remove the holder bolts and the air cleaner element.

Replace the element accordance with the maintenance schedule (page 3-3).

Also, replace the element any time it is excessively dirty or damaged.

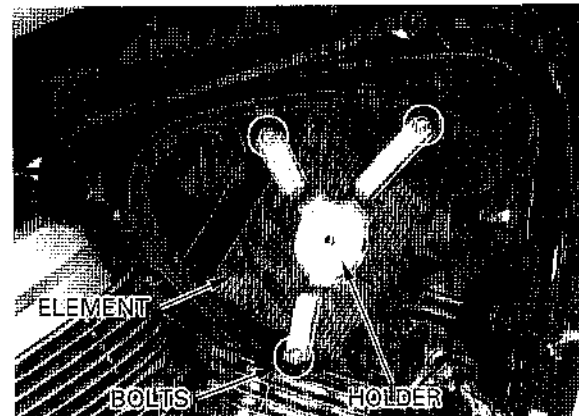

After '98: Remove the sub air cleaner case cover bolt and cover.



Remove the three bolts and air cleaner case cover.

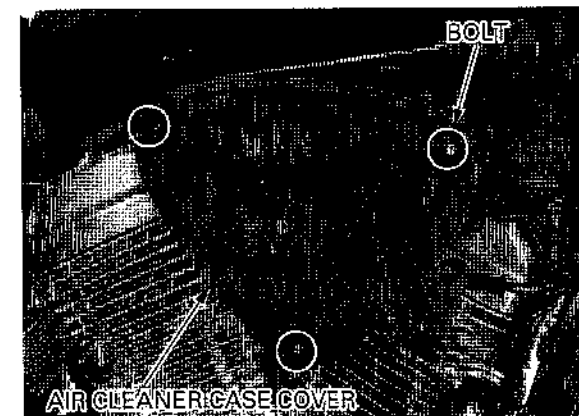



Remove the air cleaner element.  
 Replace the element accordance with the maintenance schedule (page 3-3).  
 Also, replace the element any time it is excessively dirty or damaged.



## CRANKCASE BREATHER

**NOTE:**

Service more frequently when ridden in rain, at full throttle, or after the motorcycle is washed or overturned. Service if the deposits level can be seen in the transparent section of the breather tube.

The crankcase drain tube is behind the left frame pipe.

Pull the drain tube out of the frame clamp.

Remove the drain plug from the tube to empty any deposits.

Reinstall the drain plug.

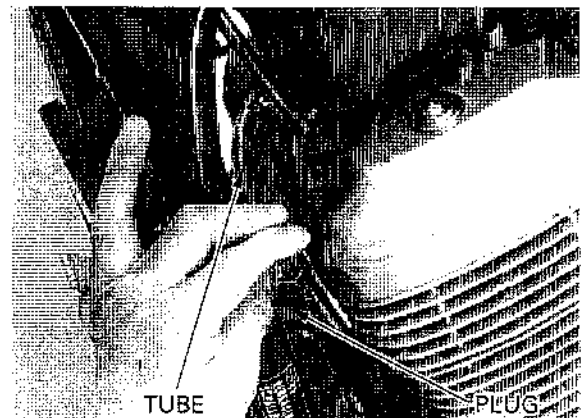

## SPARK PLUG

Disconnect the spark plug caps.

**NOTE**

Clean around the spark plug bases with compressed air before removing, and be sure that no debris enters the combustion chamber.

Remove the spark plugs using the spark plug wrench or an equivalent.

Inspect or replace as described in the maintenance schedule (page 3-3).

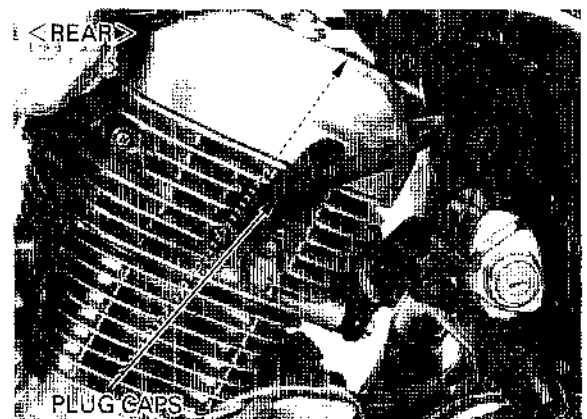

### INSPECTION

Check the following and replace if necessary (recommended spark plugs: page 3-1).

- Insulator for damage
- Electrodes for wear
- Burning condition, coloration;
  - dark to light brown indicates good condition.
  - excessive lightness indicates malfunctioning ignition system or lean mixture.
  - wet or black sooty deposit indicates over-rich mixture.

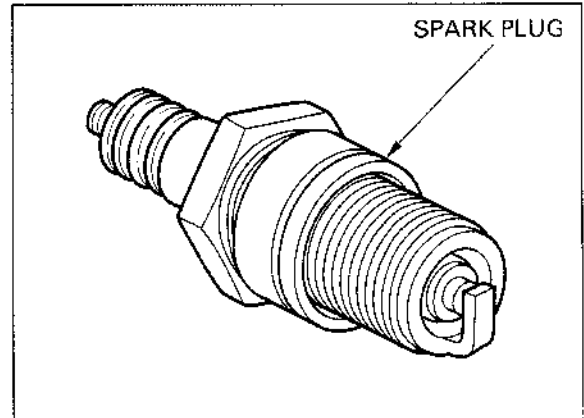

### REUSING A SPARK PLUG

Clean the spark plug electrodes with a wire brush or spark plug cleaner.

Check the gap between the center and side electrodes with a wire-type feeler gauge. If necessary, adjust the gap by bending the side electrodes carefully.

#### SPARK PLUG GAP:

0.80 – 0.90 mm (0.031 – 0.035 in)

#### CAUTION:

*To prevent damage to the cylinder head, hand tighten the spark plug before using a wrench to tighten to the specified torque.*

Reinstall the spark plug in the cylinder head and hand tighten, then torque to specification.

**TORQUE:** 14 N·m (1.4 kgf·m , 10 lbf·ft)

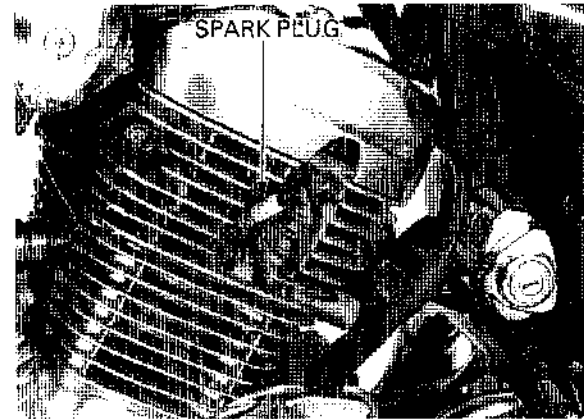
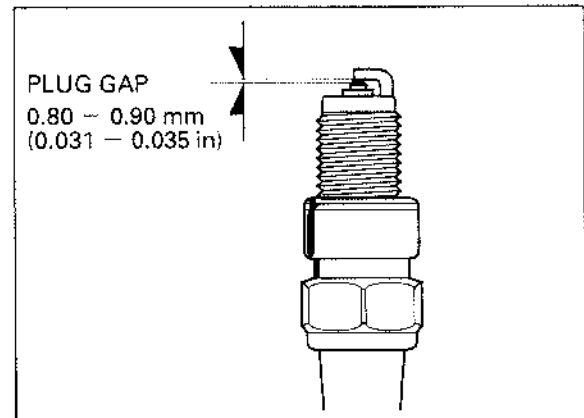

### REPLACING A SPARK PLUG

Set the plug gap to specification with a wire-type feeler gauge.

#### CAUTION:

*Do not overtighten the spark plug.*

Install and hand tighten the new spark plug, then tighten it about 1/2 of a turn after the sealing washer contacts the seat of the plug hole.

# VALVE CLEARANCE

## INSPECTION

**NOTE:**

Inspect and adjust the valve clearance while the engine is cold (below 35 °C/95 °F).

Remove the fuel tank (page 2-4).  
Remove the air cleaner housing (page 5-4).

Remove the air cleaner chamber and inlet duct.

Remove the crankshaft hole cap and timing hole cap.

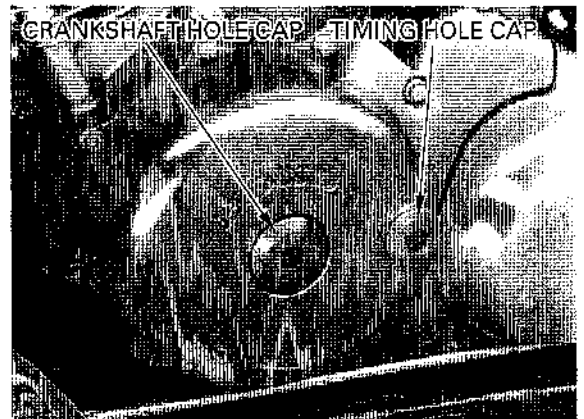

Remove the bolts and valve adjusting covers from the cylinder head covers.

**NOTE:**

Adjust the front cylinder valves first.

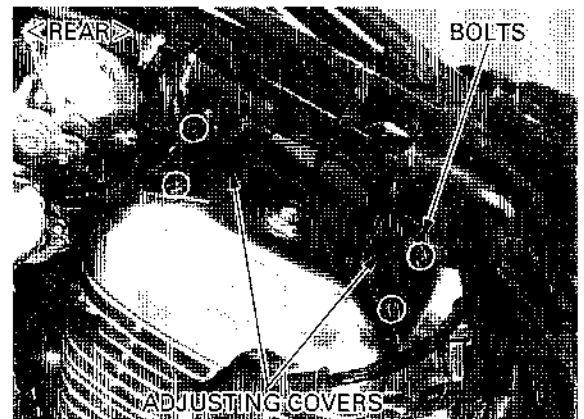
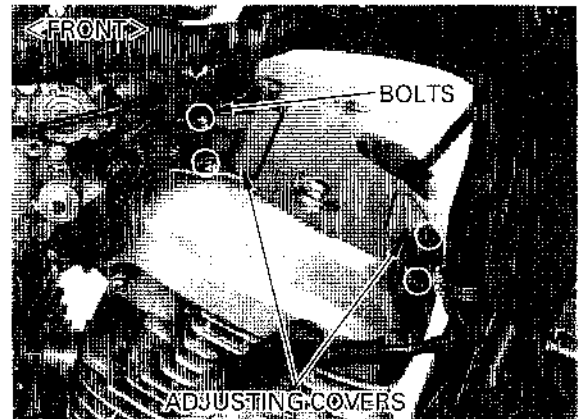

## MAINTENANCE

### FRONT CYLINDER HEAD

Rotate the flywheel counterclockwise to align the "FT" mark with the index notch on the left crankcase cover.

Make sure the piston is at TDC (Top Dead Center) on the compression stroke.

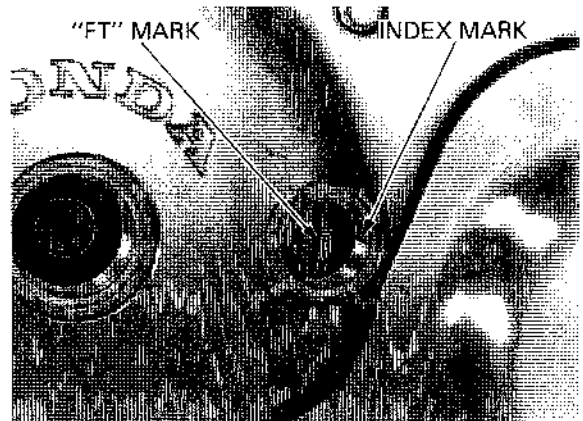

### REAR CYLINDER HEAD

Rotate the flywheel counterclockwise to align the "RT" mark with the index notch on the left crankcase cover.

Make sure the piston is at TDC (Top Dead Center) on the compression stroke.

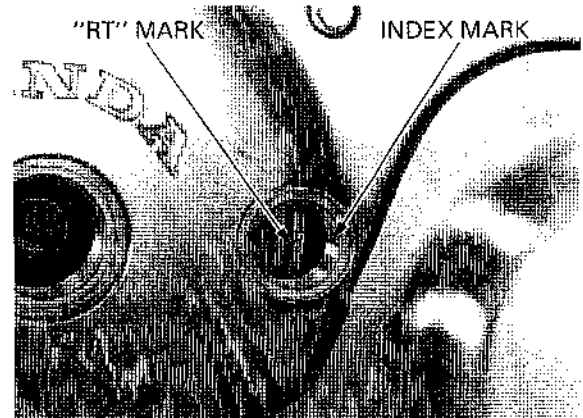

Inspect the clearance of all three valve by inserting a feeler gauge between the adjusting screw and the valve.

### VALVE CLEARANCE:

IN: 0.15 mm (0.006 in)

EX: 0.20 mm (0.008 in)

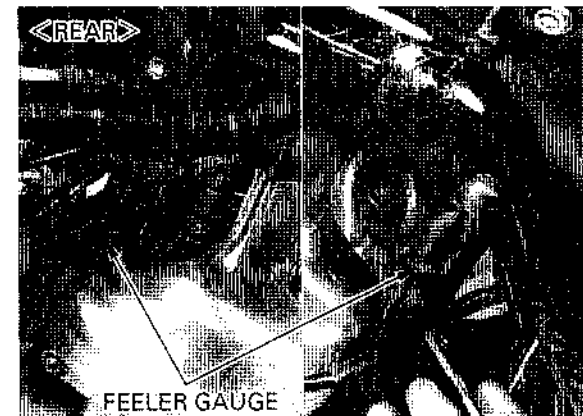
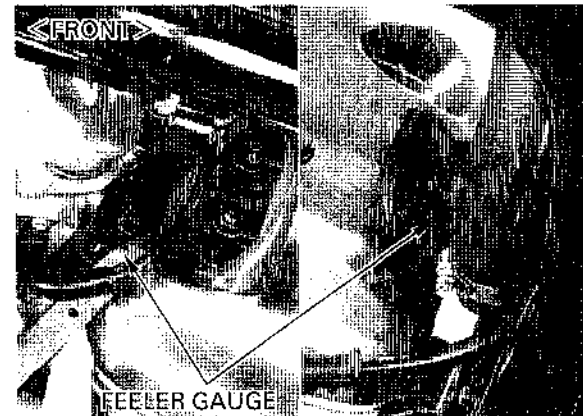

**ADJUSTMENT**

Adjust by loosening the lock nut and turning the adjusting screw until there is a slight drag on the feeler gauge.

Hold the adjusting screw and tighten the lock nut.

**TORQUE:** 23 N·m (2.3 kgf·m , 17 lbf·ft)

**TOOL:**

**Valve adjusting wrench**    07908 KE90000  
 or  
 07908---KE90100  
 (U.S.A. only)

**NOTE:**

Apply oil to the nut and bolt threads.

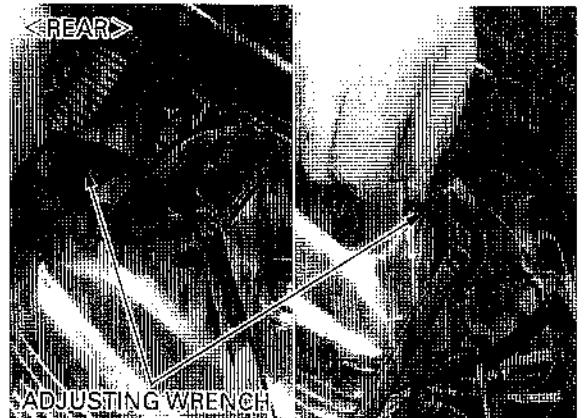
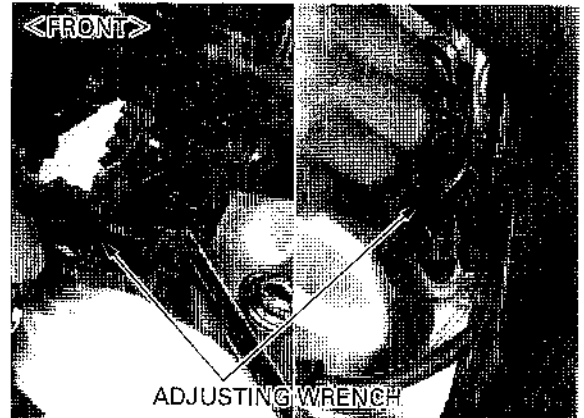

Check the O-rings of the valve adjusting covers for damage and replace if necessary.

Install the front and rear valve adjusting covers.

Tighten the cover bolts to the specified torque.

**TORQUE:** 12 N·m (1.2 kgf·m , 9 lbf·ft)

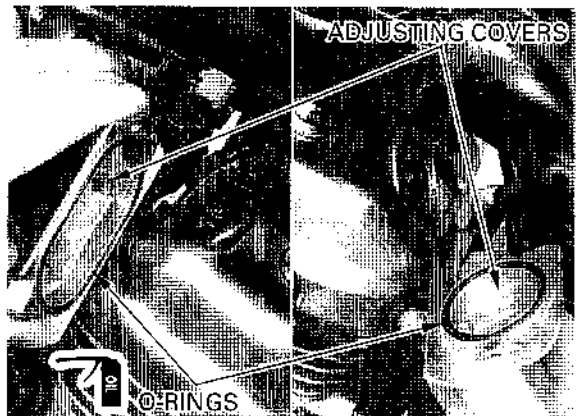

## MAINTENANCE

Apply molybdenum disulfide grease to the timing hole cap and crankshaft hole cap threads. Install and tighten the caps to the specified torque.

### TORQUE:

Timing hole cap: 15 N·m (1.5 kgf·m , 11 lbf·ft)

Crankshaft hole cap: 15 N·m (1.5 kgf·m , 11 lbf·ft)

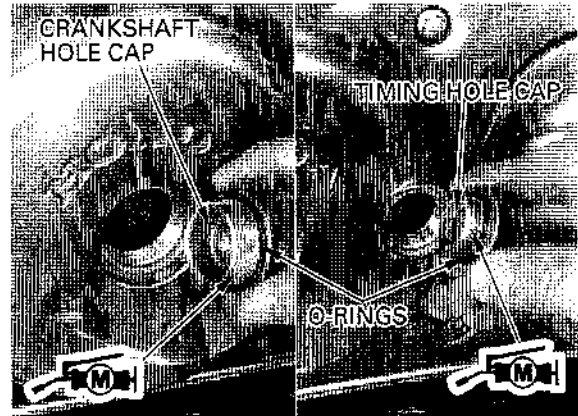

## ENGINE OIL/OIL FILTER

### OIL LEVEL INSPECTION

#### ▲WARNING

- *When the engine must be running to do some work, make sure the area is well-ventilated. Never run the engine in an enclosed area. The exhaust contains poisonous carbon monoxide gas that may cause loss of consciousness and lead to death. Run the engine in an open area or with an exhaust evacuation system in an enclosed area.*
- *Engine and exhaust system parts become very hot and remain hot for some time after the engine is run. Wear insulated gloves or wait until the engine and exhaust system have cooled before handling these parts.*

#### NOTE:

- Do not screw in the oil filler cap/level gauge when checking oil level.
- The oil level cannot be correctly measured if the motorcycle is not supported perfectly upright on a level surface.
- As the oil is gradually consumed, it is necessary to periodically check the oil level and replenish the oil volume to its proper level.
- If the oil level is too high, overall engine performance and the actuation of the clutch may be effected. Too little oil may cause engine overheating as well as premature wear to various parts.
- If a different brand or grade of oil or low quality oil is mixed when adding oil, the lubricating function deteriorates.

Support the motorcycle in an upright and level position using a hoist or a jack under the engine.

Start the engine and let it idle for a few minutes. Stop the engine and wait 2 - 3 minutes.

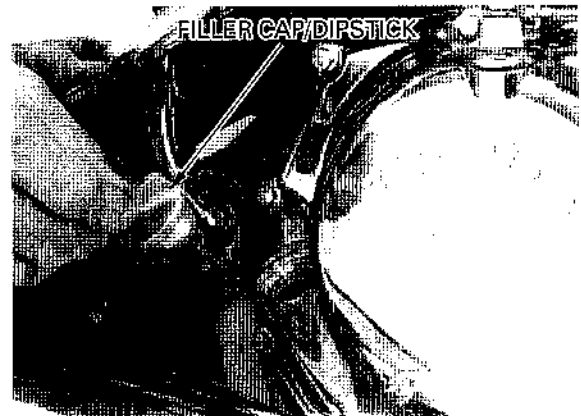

Remove the oil filler cap/dipstick and wipe off the oil from the dipstick with a clean cloth.

With the motorcycle upright on level ground, insert the oil filler cap/dipstick into the stick hole without screwing it in.

Remove the oil filler cap/dipstick and check the oil level.

If the level is below or near the lower level mark on the dipstick, fill to the upper level mark with the recommended oil.

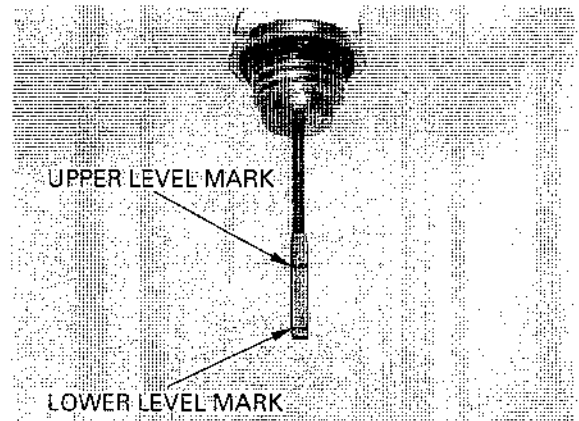

**RECOMMENDED ENGINE OIL:**

Honda GN4 or HP4 4-stroke oil or HONDA 4-stroke oil or equivalent motorcycle oil API service classification SF or SG Viscosity: SAE 10W-40

**NOTE:**

Other viscosities shown in the chart may be used when the average temperature in your riding area is within the indicated range.

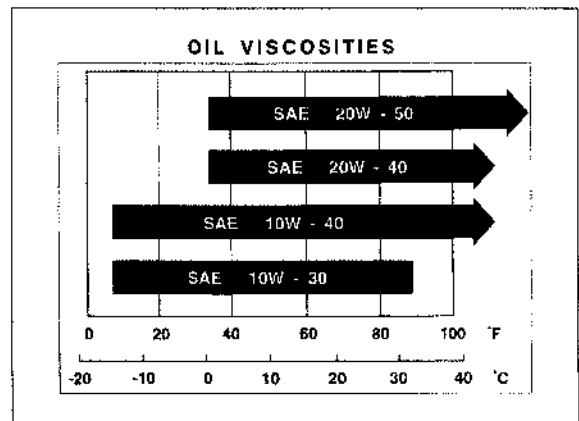

Check the O-ring for damage.  
Reinstall the oil filler cap/dipstick.

**ENGINE OIL CHANGE**

**▲WARNING**

- *When the engine must be running to do some work, make sure the area is well-ventilated. Never run the engine in an enclosed area. The exhaust contains poisonous carbon monoxide gas that may cause loss of consciousness and lead to death. Run the engine in an open area or with an exhaust evacuation system in an enclosed area.*
- *Engine and exhaust system parts become very hot and remain hot for some time after the engine is run. Wear insulated gloves or wait until the engine and exhaust system have cooled before handling these parts.*

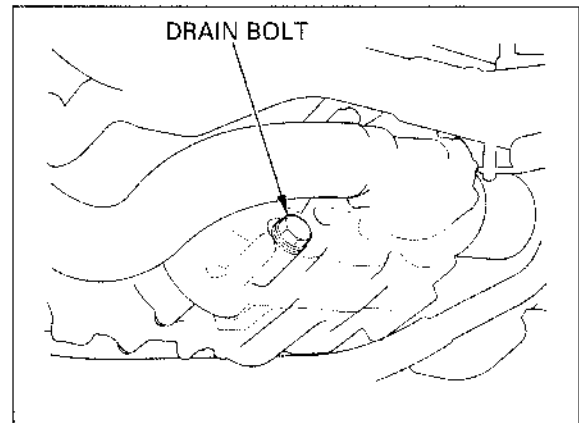

**NOTE:**

Change the engine oil with the engine warm and the motorcycle on its side stand to assure complete and rapid draining.

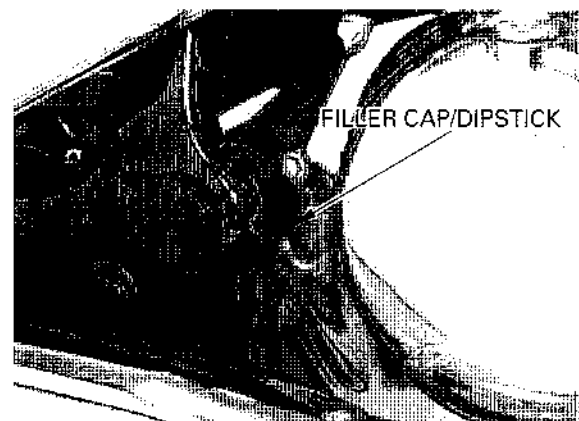

Warm up the engine.  
Place an oil drain pan under the engine to catch the oil, then remove the oil drain bolt and oil filler cap/dipstick.

## MAINTENANCE

With the engine stop switch "OFF", push the starter button for a few seconds to drain any oil which may be left in the engine.

### NOTE:

Do not operate the motor for more than few seconds.

After draining the oil completely, check that the sealing washer on the drain bolt is in good condition and replace if necessary.

Tighten the drain bolt to the specified torque.

**TORQUE:** '97 – '98: 34 N·m (3.5 kgf·m , 25 lbf·ft)  
After '98: 30 N·m (3.1 kgf·m , 22 lbf·ft)

Fill the crankcase with the recommended engine oil.

### OIL CAPACITY:

2.1 ℓ (2.2 US qt , 1.8 Imp qt) at draining  
2.8 ℓ (3.0 US qt , 2.5 Imp qt) at disassembly  
2.25 ℓ (2.38 US qt , 1.98 Imp qt) at oil filter change

Install the oil filler cap/dipstick.

Start the engine and let it idle for 2 or 3 minutes. Stop the engine and wait a few minutes, then check that the oil level is at the upper level mark with the motorcycle upright.

Check that there are no oil leaks.

## OIL FILTER CHANGE

### ▲WARNING

- *When the engine must be running to do some work, make sure the area is well-ventilated. Never run the engine in an enclosed area. The exhaust contains poisonous carbon monoxide gas that may cause loss of consciousness and lead to death. Run the engine in an open area or with an exhaust evacuation system in an enclosed area.*
- *Engine and exhaust system parts become very hot and remain hot for some time after the engine is run. Wear insulated gloves or wait until the engine and exhaust system have cooled before handling these parts.*

Drain the engine oil (page 3-16).

Remove the oil filter using the oil filter wrench.

### TOOL:

Oil filter wrench                      07HAA·PJ70100

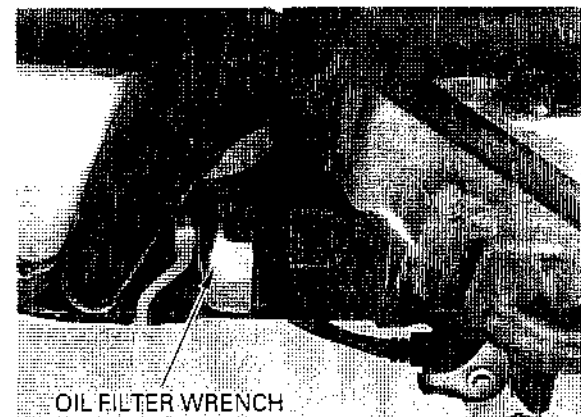
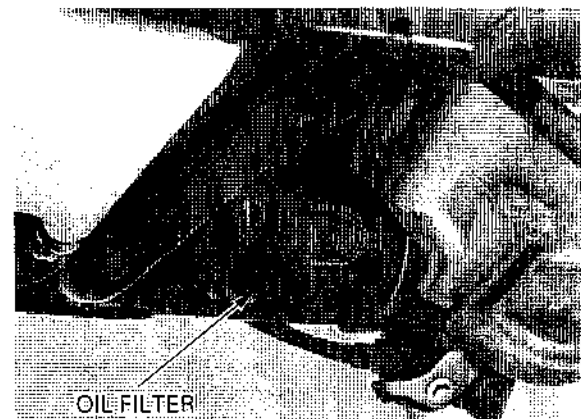
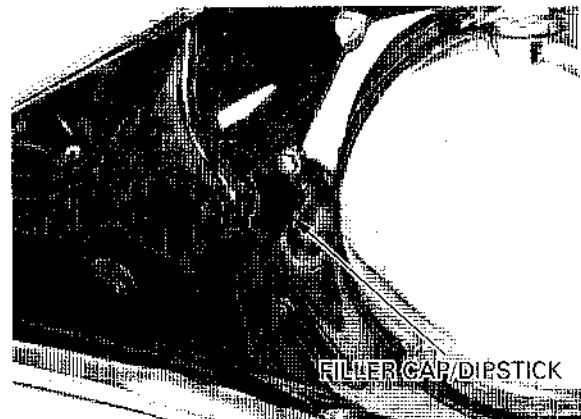
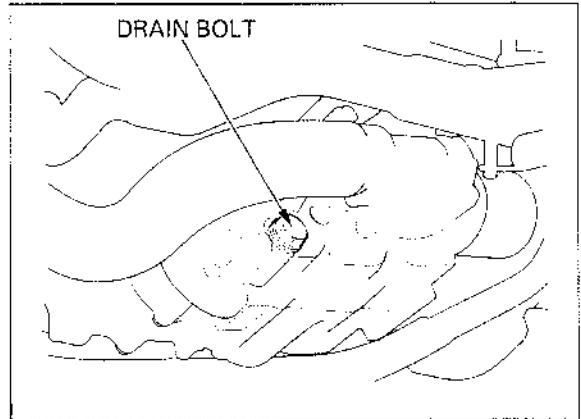



Apply engine oil to the new oil filter threads and the O-ring.  
Install and tighten the new oil filter to the specified torque.

**TORQUE:** 10 N·m (1.0 kgf·m, 7 lbf·ft)

Fill the crankcase with the recommended engine oil (page 3-15).  
Install the oil filler cap/dipstick.  
Start the engine and recheck the oil level (page 3-15).  
Make sure that there are no oil leaks.

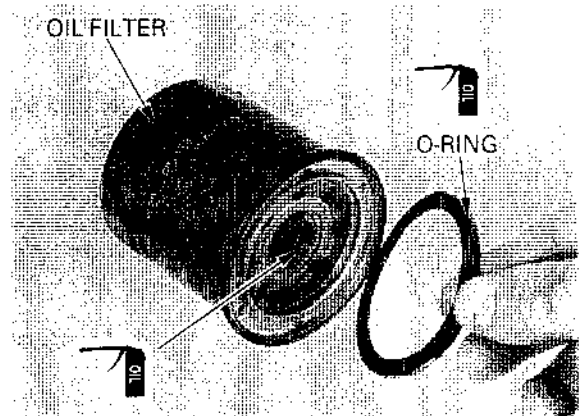

## CARBURETOR SYNCHRONIZATION ('97 - '98)

**▲WARNING**

*When the engine must be running to do some work, make sure the area is well-ventilated. Never run the engine in an enclosed area. The exhaust contains poisonous carbon monoxide gas that may cause loss of consciousness and lead to death. Run the engine in an open area or with an exhaust evacuation system in an enclosed area.*

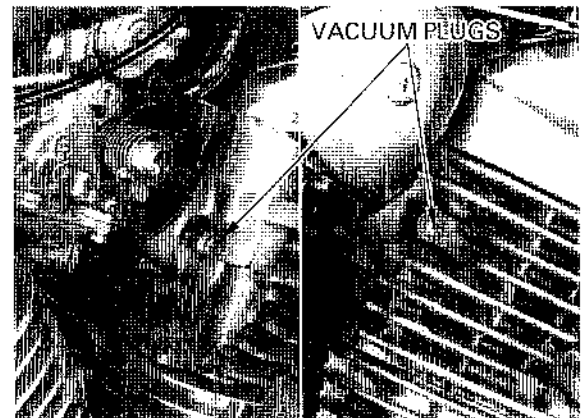

**NOTE:**

Perform this maintenance with the engine at normal operating temperature and transmission in neutral. Place the motorcycle on a level surface.

Remove the fuel tank mounting bolt. Carefully raise the tank and support it in the frame using a suitable base.

Remove the air cleaner housing (page 5-4).

Remove the vacuum plugs and washers from the cylinder head intake ports.  
Connect the vacuum gauge and attachment.

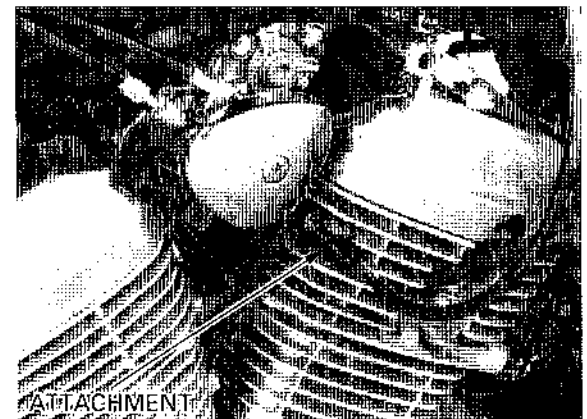

**TOOL:**

**Vacuum gauge**            07404 - 0030000  
   or  
   07LMJ - 001000A  
   (U.S.A. only)

Connect the suitable tube between fuel tank and fuel tube.

1. Turn the fuel valve ON. Start the engine and adjust the idle speed to the specification.

**IDLE SPEED:** 1,200 ± 100 rpm

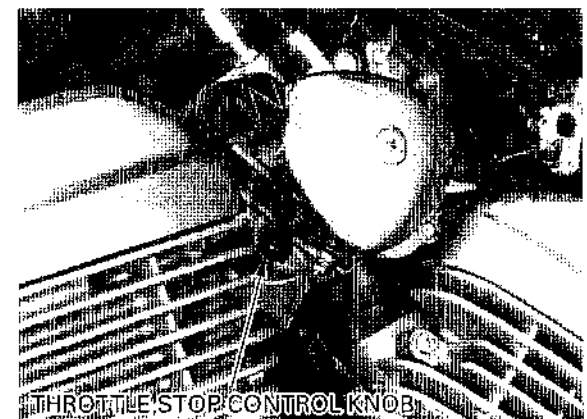

## MAINTENANCE

2. Check the difference in vacuum between each carburetor.

### CARBURETOR VACUUM DIFFERENCE:

27 kPa (20 mmHg, 0.7 in Hg)

### NOTE:

The base carburetor is the Rear (No.1) carburetor.

3. Synchronize to specification by turning the adjusting screw.
4. Be sure that the synchronization is stable by snapping the throttle grip several times.
5. Snap the throttle grip several times and recheck the idle speed and difference in vacuum between each carburetor.

Disconnect the vacuum gauge and attachment.  
Install the vacuum plugs and washers and tighten the plugs to the specified torque.  
Install the removed parts.

**TORQUE:** 3 N·m (0.33 kgf·m , 2.4 lbf·ft)

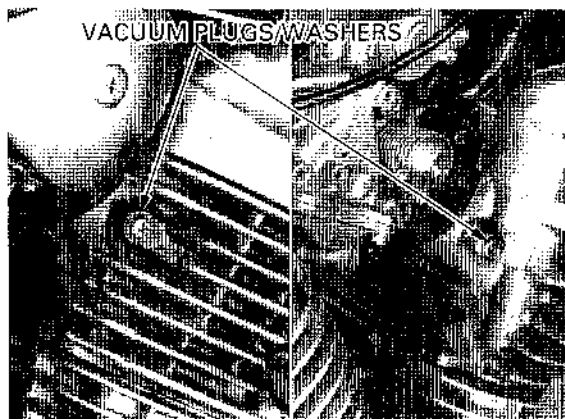
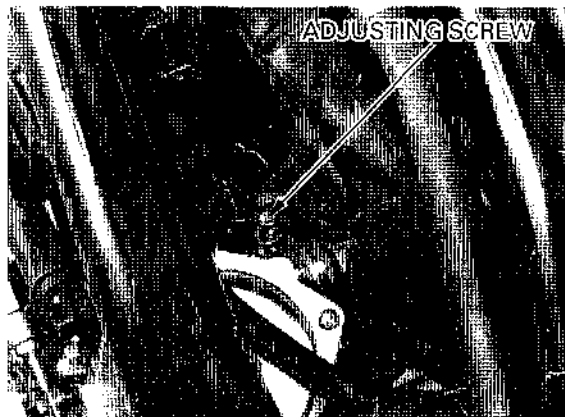

## ENGINE IDLE SPEED

### ▲WARNING

*When the engine must be running to do some work, make sure the area is well-ventilated. Never run the engine in an enclosed area. The exhaust contains poisonous carbon monoxide gas that may cause loss of consciousness and lead to death. Run the engine in an open area or with an exhaust evacuation system in an enclosed area.*

### NOTE:

- Perform this maintenance with the engine at normal operating temperature and transmission in neutral. Place the motorcycle on a level surface.
- Engine must be warm for accurate adjustment. Ten minutes of stop-and-go riding is sufficient.

Warm up the engine and shift the transmission into neutral.  
Place the motorcycle on its side stand.  
Check the idle speed and adjust by turning the throttle stop control knob if necessary.

**IDLE SPEED:** 1,200 ± 100 rpm

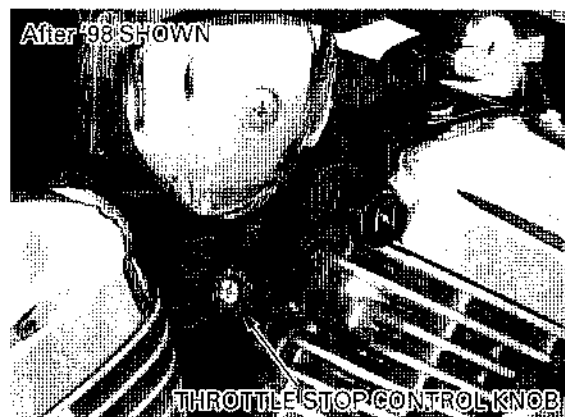
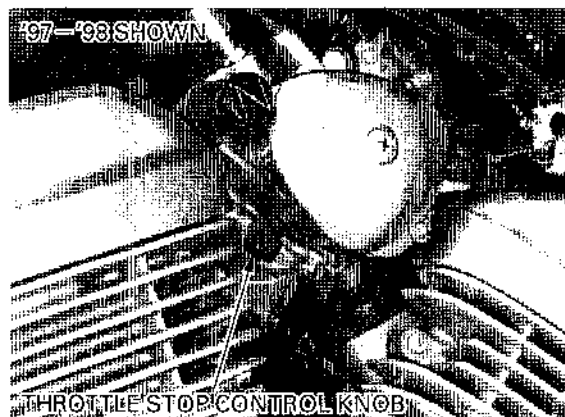

## RADIATOR COOLANT LEVEL CHECK

**▲WARNING**

- *Wait until the engine is cool before removing the radiator cap. Removing the cap while the engine is hot and the coolant is under pressure may cause serious scalding.*
- *Radiator coolant is poisonous. Take care to avoid getting coolant in your eyes, on your skin, or on your clothes.*
- *If coolant gets in your eyes, flush repeatedly with water and contact a doctor immediately.*
- *If coolant is accidentally swallowed, induce vomiting and contact a doctor immediately.*
- **KEEP OUT REACH OF CHILDREN.**

Check the coolant level of the reserve tank with the engine running at normal operating temperature. The level should be between the "UPPER" and "LOWER" level lines with the motorcycle in a vertical position on a flat, level surface.

If necessary, remove the right side cover (page 2-3) and reserve tank cap and fill to the "UPPER" level line with a 50-50 mixture of distilled water and antifreeze (coolant mixture preparation: page 6-5).

**CAUTION:**

*Be sure to use the proper mixture of antifreeze and distilled water to protect the engine. use distilled water. Tap water may cause the engine to rust or corrode.*

Check to see if there are any coolant leaks when the coolant level decreases very rapidly.

If the reserve tank becomes completely empty, there is a possibility of air getting into the cooling system.

Be sure to remove all air from the cooling system as described on page 6-6.

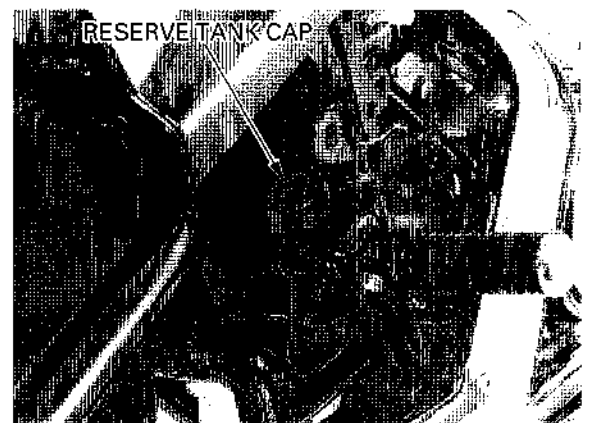
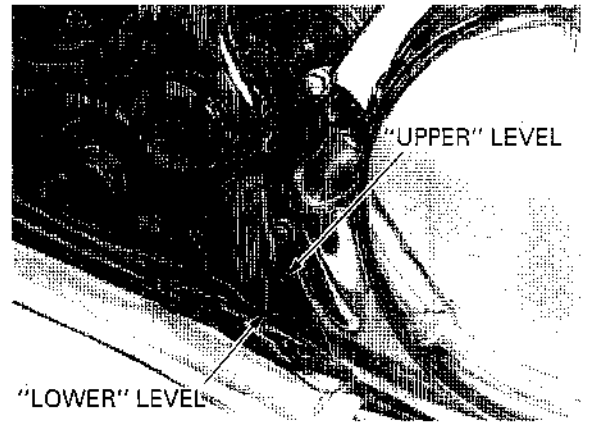

## COOLING SYSTEM

**▲WARNING**

*To prevent injury, keep your hands and clothing away from the cooling fan. It may start automatically, without warning.*

Check the radiator air passage for clogging or damage.

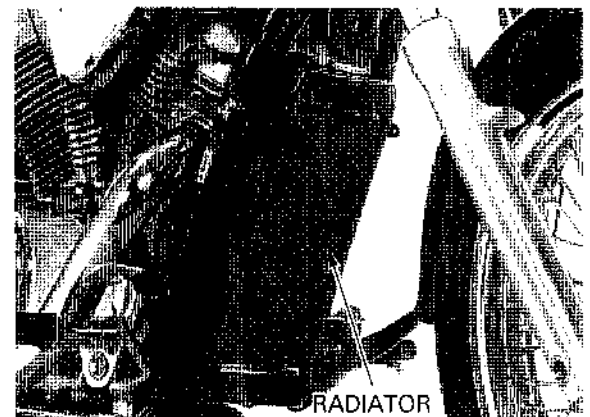

## MAINTENANCE

Straighten bent fins with a small, flat blade screwdriver and remove insects, mud or other obstructions with compressed air or low pressure water.

Replace the radiator if the air flow is restricted over more than 20 % of the radiating surface.

For radiator replacement, refer to page 6-8.



Remove the fuel tank and steering covers (section 2).

Check for any coolant leakage from the water pump, water hose and hose joints.

Make sure the hoses are in good condition; they should not show any signs of deterioration.

Replace any hose that shows any sign of deterioration.

Check that all hose clamps are tight.

For radiator replacement, refer to page 6-9.



## EVAPORATIVE EMISSION CONTROL SYSTEM (CALIFORNIA TYPE ONLY)

Check the tank between the fuel tank, EVAP canister, EVAP purge control valve and carburetor for deterioration, damage or loose connections.

Check the EVAP canister for cracks or other damage.

Refer to the Vacuum Hose Routing Diagram Label and Cable & Harness Routing (page 1-32, 37) for tube connections.

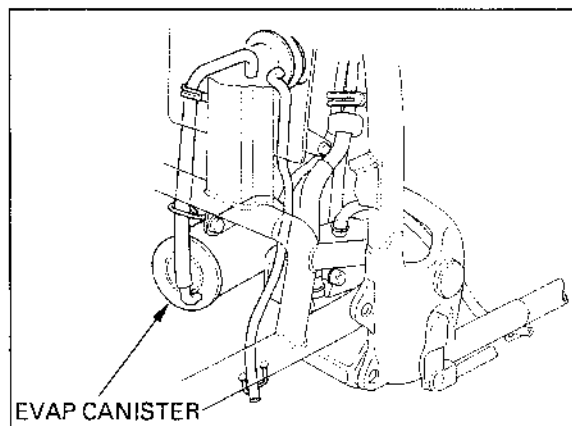

## DRIVE CHAIN

### DRIVE CHAIN SLACK INSPECTION

#### **▲WARNING**

*Inspecting the drive chain while the engine is running can result in serious hand or finger injury.*

Turn the ignition switch OFF, place the motorcycle on its side stand and shift the transmission in neutral.

Check the slack in the drive chain lower run, midway between the sprockets.

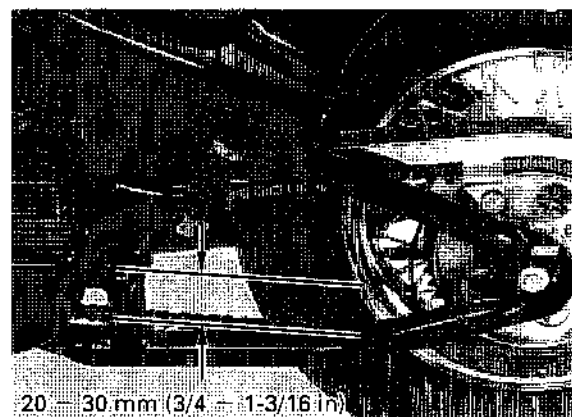

**DRIVE CHAIN SLACK:**

20–30 mm (3/4 – 1-3/16 in)

**CAUTION:**

**Excessive chain slack, 50 mm (2.0 in) or more, may damage the frame.**

Lubricate the drive chain with Pro Honda Chain Lube designed specifically for use with O-ring chains. Wipe off the excess chain lube.

**ADJUSTMENT**

**CAUTION:**

*If the adjustment is not the same on both sides, the wheel is out of alignment and can cause excessive tire, sprocket and chain wear.*

Loosen the rear axle nut.  
Turn both adjusting bolts until the correct drive chain slack is obtained.  
Make sure the index marks on the both adjusters are aligned with the rear end of the swingarm.  
Tighten the rear axle nut to the specified torque.

**TORQUE:** 88 N·m (9.0 kgf·m , 65 lbf·ft)

Recheck the drive chain slack and free wheel rotation.  
Lubricate the drive chain with Pro Honda Chain Lube designed specifically for use with O-ring chains. Wipe off the excess chain lube.  
Check the drive chain wear indicator label attached on the left drive chain adjuster.  
If the index mark reaches the red zone of the indicator label, replace the drive chain with a new one (page 3-22).

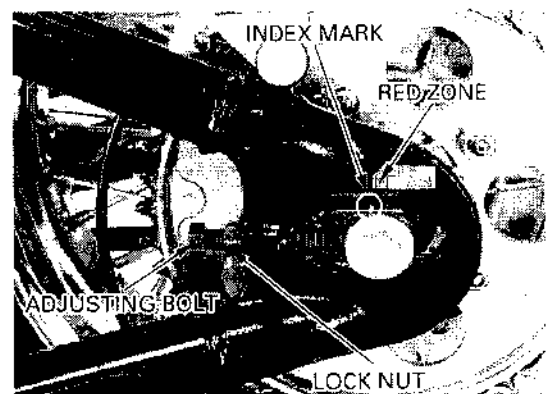
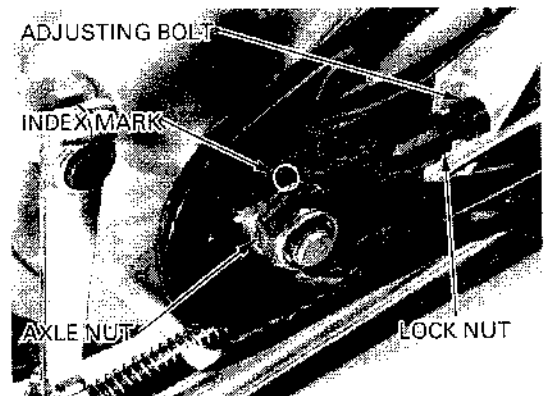

**CLEANING, INSPECTION AND LUBRICATION**

**CAUTION:**

- Chains with O-rings should not be treated to the following cleaning and oiling procedure. This treatment will cause degradation of the O-rings and loss of grease, thus shortening chain life.
- Do not use steam or high pressure water washing. Use a chain spray containing a cleaning agent or use high flash point solvent to clean the chain.

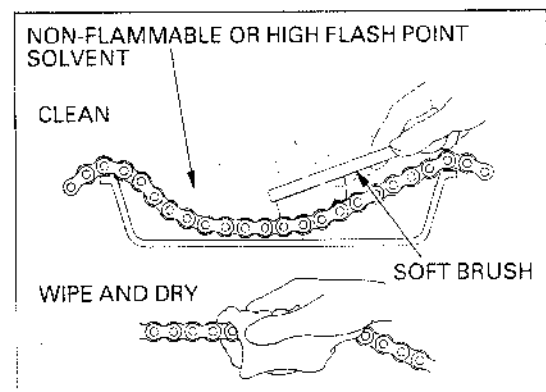

## MAINTENANCE

Clean the chain with suitable detergent and wipe it dry.

Be sure the chain has dried completely before lubricating.

Inspect the drive chain for possible damage or wear.

Replace any chain that has damaged rollers, loose fitting links, or otherwise appears unserviceable.

Installing a new chain on badly worn sprockets will cause the new chain to wear quickly. Inspect and replace sprockets as necessary.

Lubricate the drive chain with Pro Honda Chain Lube designed specifically for use with O-ring chains. Wipe off the excess chain lube.

### LUBRICATE

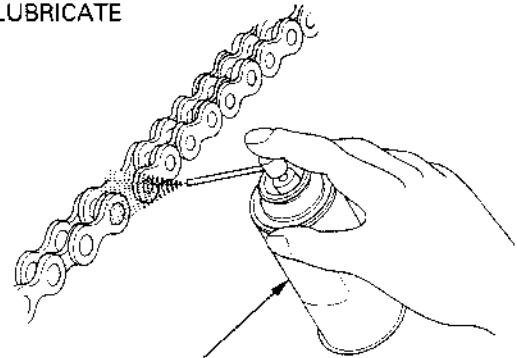

PRO HONDA CHAIN LUBE OR EQUIVALENT

## SPROCKET INSPECTION

Inspect the drive and driven sprocket teeth for damage or wear. Replace if necessary.

Never use a new drive chain on worn sprockets. Both chain and sprockets must be in good condition, or the new replacement chain will wear rapidly.

Check the attachment bolts and nuts on the drive and driven sprockets.

If any are loose, torque them to the proper specification.

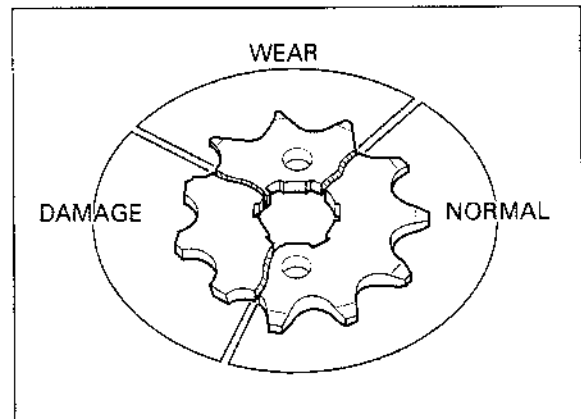

## REPLACEMENT

### CAUTION:

*Because of the drive chain is master link joint pin staking type (the ends of the pins are expanded with the special tool), the specified types of chain and special tool must be used to replace. Do not use clip type chains.*

This motorcycle uses a drive chain with a staked master link.

Loosen the drive chain (page 3-21).

Assemble the special tool.

### TOOL:

Drive chain tool set

07HMH - MR10103 or  
07HMH - MR1010A  
(U.S.A. only)

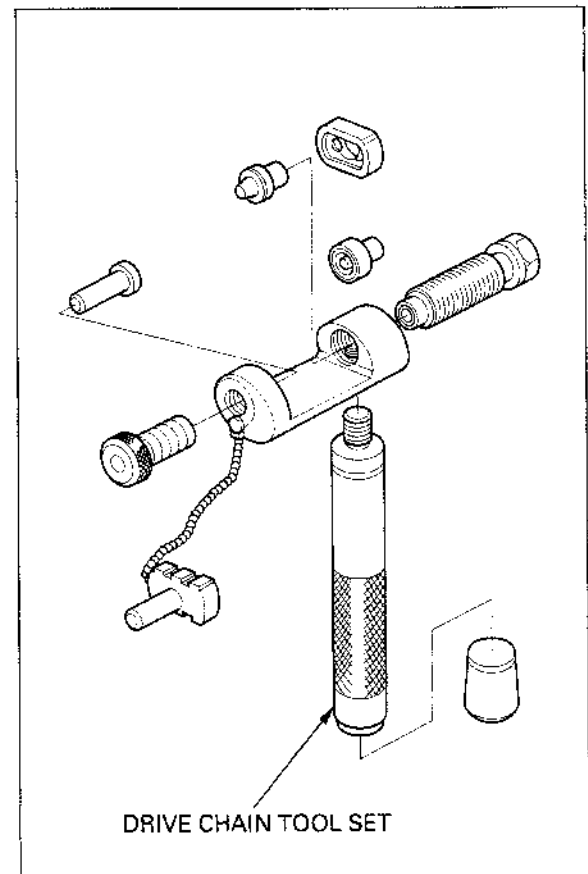

**NOTE:**

When using the special tool, follow the manufacturer's operating instructions.

Locate the drive chain cutter on the staked part of the drive chain and cut the staked pins.

**TOOL:**

**Drive chain tool set** 07HMH – MR10103 or  
07HMH – MR1010A  
(U.S.A. only)

Remove the drive chain.

Remove the excess drive chain links from the new drive chain with the drive chain cutter.

**NOTE:**

- One (1) link is indicated as the figure on the right.
- Include the master link when you count the drive chain links.

**STANDARD LINKS:** 120L  
**REPLACEMENT CHAIN:** RK: 525 SM5  
DID: 525 V8

Install the new drive chain over the swingarm.

**CAUTION:**

*Never reuse the old master link, master link plate and O-rings.*

Install the new O-rings onto the new master link, and insert the master link from the inside of the drive chain taking care to prevent squeezing. Install the O-rings and the link plate with the drive chain cutter.

**TOOL:**

**Drive chain tool set** 07HMH – MR10103 or  
07HMH – MR1010A  
(U.S.A. only)

**NOTE:**

- Install the link plate with the identification mark facing the outside.
- Take care to prevent squeezing of the O-rings.
- Do not remove initially applied grease from the link to lubricate.

Remove the special tool and check the master link pin length projected from the plate.

**STANDARD LENGTH:** 1.2 – 1.4 mm (0.05 – 0.06 in)

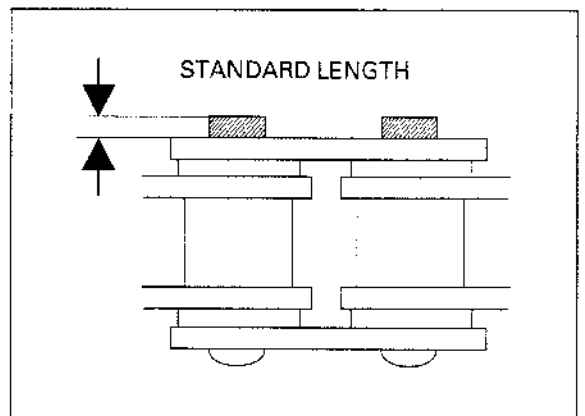
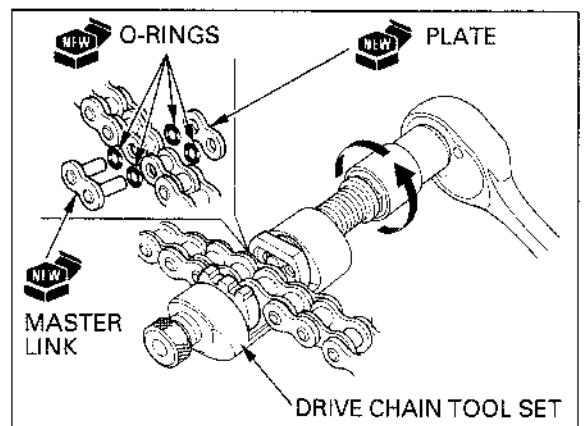
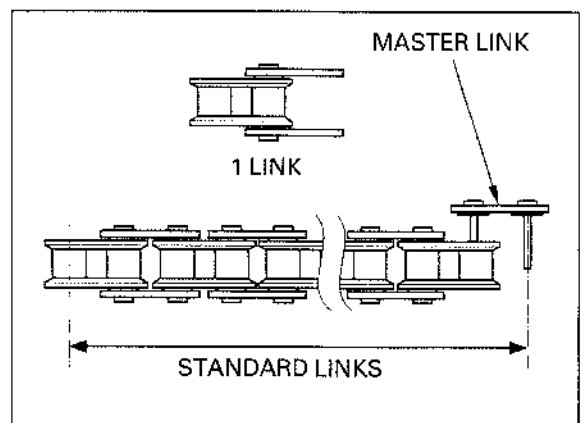
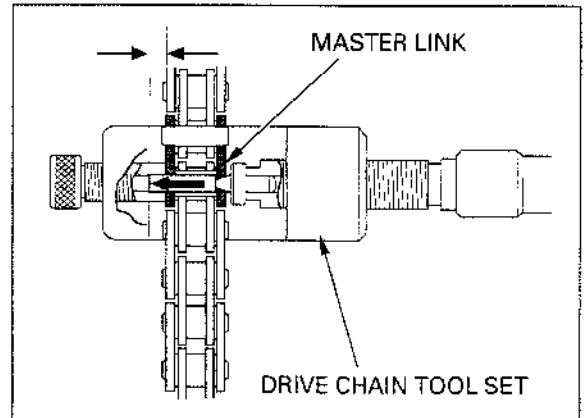

## MAINTENANCE

Stake the master link pins with the drive chain tool set.

**TOOL:**

**Drive chain tool set**      07HMH-MR10103 or  
07HMH-MR1010A  
(U.S.A. only)

**NOTE:**

To prevent over staking, stake gradually checking the diameter of the staked area using slide calipers.

After staking, check the staked area of the master link using slide calipers.

**DIAMETER OF THE STAKED AREA:**

5.50 - 5.80 mm (0.217 - 0.228 in)

**NOTE:**

- When the measured staked area is over the prescribed value, restake using the new master link, plate and O-rings.
- When the measured staked area is below the prescribed value, reinstall the drive chain cutter and restake.

Check the staked area of the master link for cracks and the O-rings for damage.

If there is any cracking or damage, replace the master link, plate and O-rings.

**CAUTION:**

*A drive chain with a clip-type master link must not be used.*

Check that master link pivots freely on the pins. If the movement is not smooth, restake using the new master link, plate and O-rings.

Adjust the drive chain play.

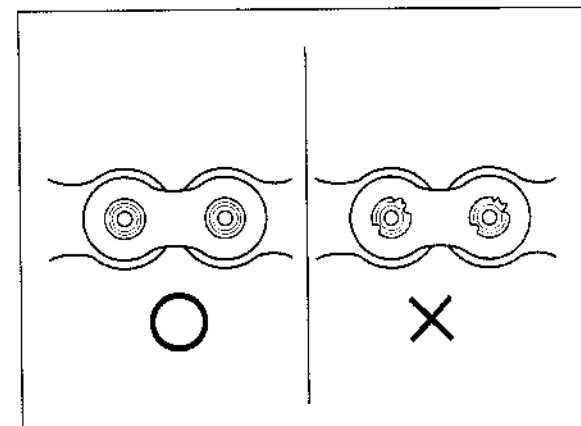
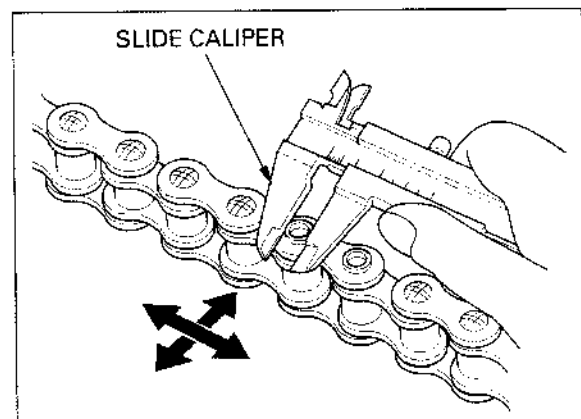
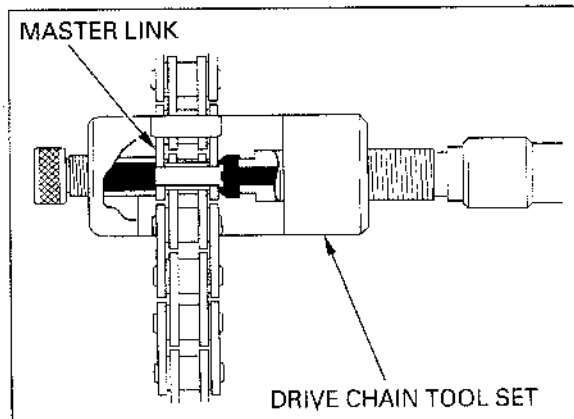

## BRAKE FLUID

**CAUTION:**

- Do not remove the cover or cap unless the reservoir is level because fluid may spill out.
- Do not mix different types of fluid, as they are not compatible with each other.
- Do not allow foreign material to enter the system when filling the reservoir.
- Avoid spilling fluid on painted, plastic or rubber parts. Place a rug over these parts whenever the system is serviced.

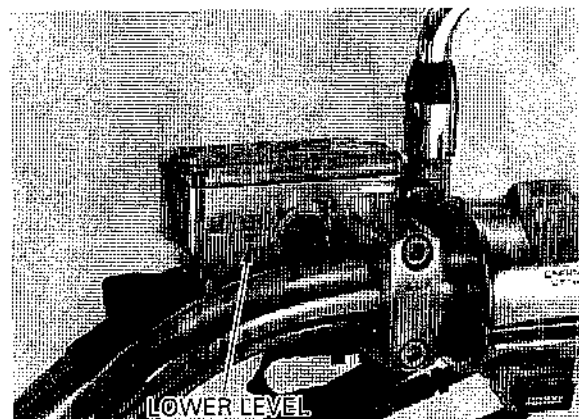



**NOTE:**

- When the fluid level is low, check the brake pads for wear (see below). A low fluid level may be due to wear of the brake pads. If the brake pads are worn, the caliper piston is pushed out, and this accounts for a low reservoir level. If the brake pads are not worn and the fluid level is low, check entire system for leaks (page 3-26).
- Do not remove the level float from the reservoir when filling with brake fluid.

Turn the handlebar to the left side so that the reservoir is level and check the front brake reservoir level through the sight glass. If the level (float edge) is near the lower level mark, remove the cover, set plate and diaphragm and fill the reservoir to the casting ledge with DOT 4 brake fluid from a sealed container.

Refer to page 15-3 for brake fluid replacement/bleeding procedures.

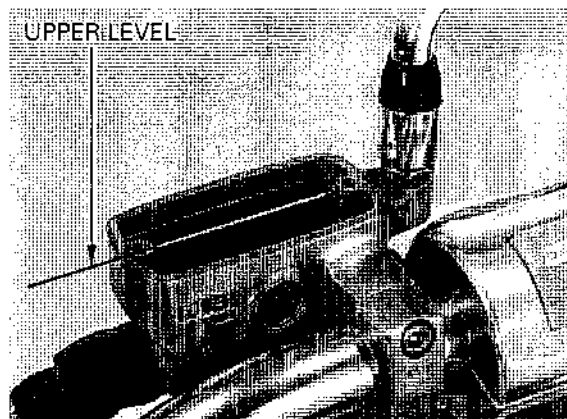

## BRAKE SHOE/PAD WEAR

### FRONT BRAKE PADS

Check the brake pad for wear. Replace the brake pads if either pad is worn to the bottom of wear limit groove.

Refer to page 15-5 for brake pad replacement.

**CAUTION:**

*Always replace the brake pads as a set to ensure even disc pressure.*

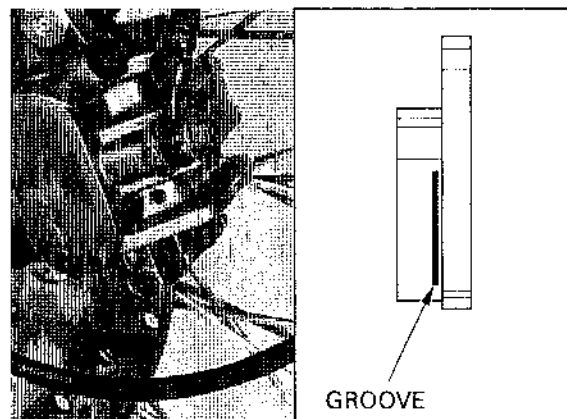

### REAR BRAKE SHOE

Replace the brake shoes if the arrow on the brake arm aligns with the reference mark "△" on full application of the rear brake pedal.

Refer to page 14-11 for brake pad replacement.

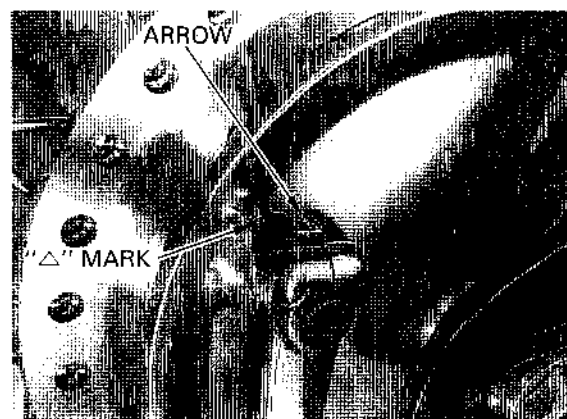

**BRAKE SYSTEM**

**INSPECTION**

Firmly apply the brake lever or pedal, and check that no air has entered the system. If the lever or pedal feels soft or spongy when operated, bleed air from the system.

Inspect the brake hoses and fittings for deterioration, cracks and signs of leakage. Tighten any loose fittings.  
Replace hoses and fittings as required.

Refer to page 15-3 for brake bleeding procedures.

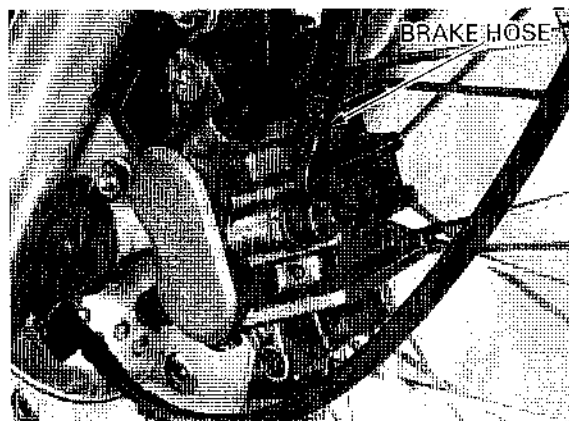
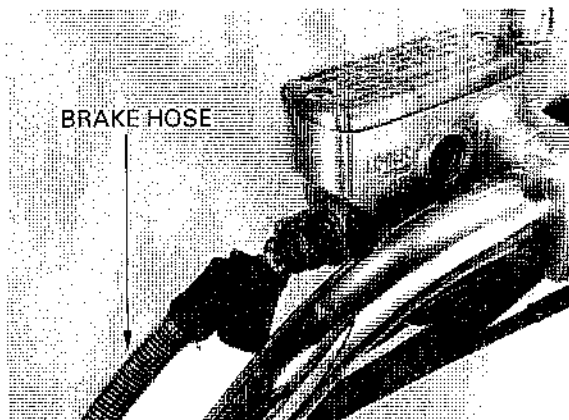

**BRAKE PEDAL HEIGHT**

Check the brake pedal height

**BRAKE PEDAL HEIGHT:**

43 mm (1.7 in) above the top of the footpeg

To adjust:

Loosen the stopper bolt lock nut and turn the stopper bolt.

Retighten the lock nut.

**NOTE:**

After adjustment the brake pedal height, check the rear brake light switch and brake pedal free play, adjust if necessary.

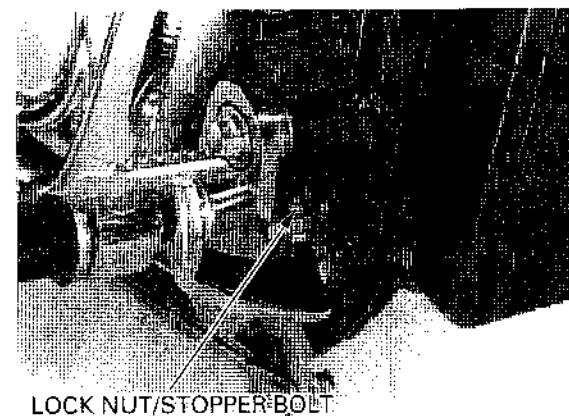
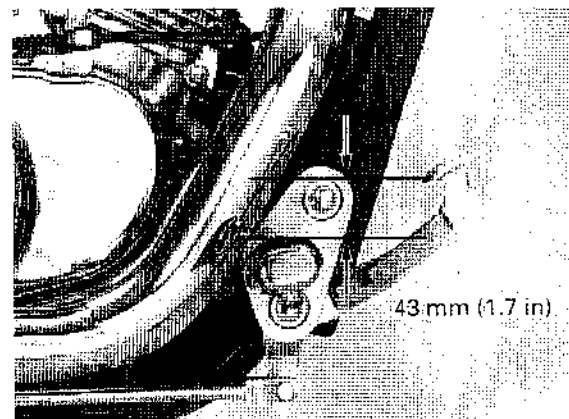

## BRAKE PEDAL FREE PLAY

**NOTE:**

Perform brake pedal free play adjustment after adjusting brake pedal height.

Check the brake pedal free play.

**FREE PLAY:** 20–30 mm (3/4 – 1-1/4 in)

If adjustment is necessary, use the rear brake adjusting nut.

**NOTE:**

After adjusting the brake pedal free play, check the rear brake light switch operation and adjust if necessary.

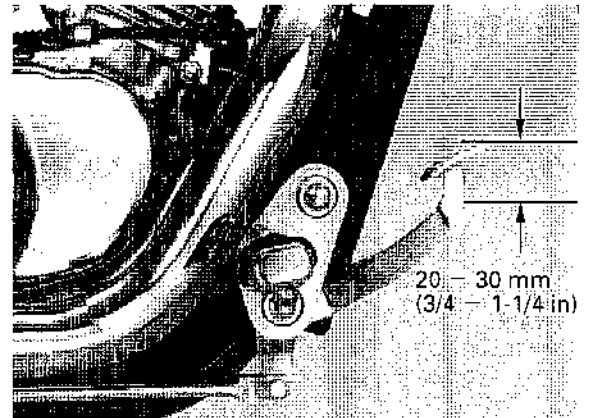

## BRAKE LIGHT SWITCH

**CAUTION:**

*Allowing the switch body to turn during adjustment can break the wires in the switch.*

**NOTE:**

- The brake light switch on the front brake lever cannot be adjusted. If the front brake light switch actuation and brake engagement are off, either replace the switch unit or the malfunctioning parts of the system.
- Make all rear brake light switch adjustments after the height adjustment and the brake pedal free play adjustments have been made.

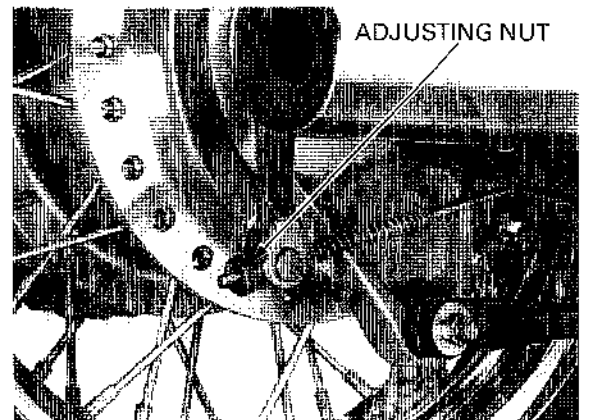

Check the brake light switch operation and adjustment by applying the brakes. Visually inspect for any damage and make sure the reflector plate is clean within the light.

Adjust the rear brake light switch so that the brake light comes on just prior to the brake actually being engaged. If the light fails to come on, adjust the switch so that the light comes on at the proper time.

Turn the adjusting nut on the brake light switch and not the switch body and wires to make switch actuation adjustments.

*Be sure to hold the switch body firmly while turning the adjusting nut.*

After adjustment, recheck to be sure the brake light comes on at the proper time.

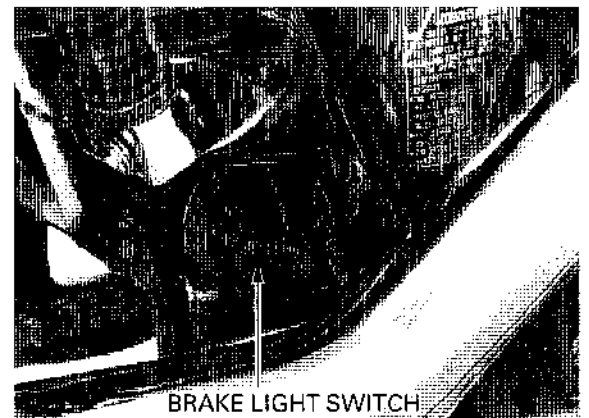

## HEADLIGHT AIM

**▲WARNING**

*An improperly adjusted headlight may blind oncoming drivers, or it may fail to light the road for a safe distance.*

*Adjust the headlight beam as specified by local laws and regulation.*

Place the motorcycle on a level surface.

Adjust the headlight beam vertically turning the vertical beam adjusting screw.

A clockwise rotation moves the beam up.

Horizontal beam adjustments are made using the horizontal beam adjusting screw.

A clockwise rotation moves the beam toward the right side of the rider.

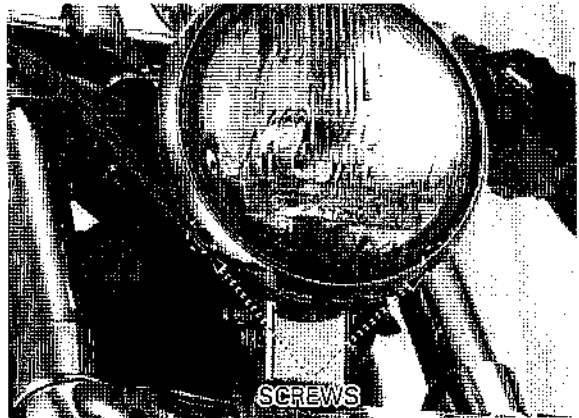

## CLUTCH SYSTEM

Measure the clutch free play at the end of the clutch lever.

**FREE PLAY:** 10–20 mm (3/8 – 3/4 in)

Adjust as follows:

Minor adjustments are made at the adjuster near the lever.

Loosen the lock nut and turn the adjuster. Tighten the lock nut.

**CAUTION:**

*The adjuster may be damaged if it is positioned too far out, leaving minimal thread engagement.*

If the adjuster is threaded out near its limit and the correct free play cannot be obtained, turn the adjuster all the way in and back out one turn. Tighten the lock nut and make a major adjustment as described below.

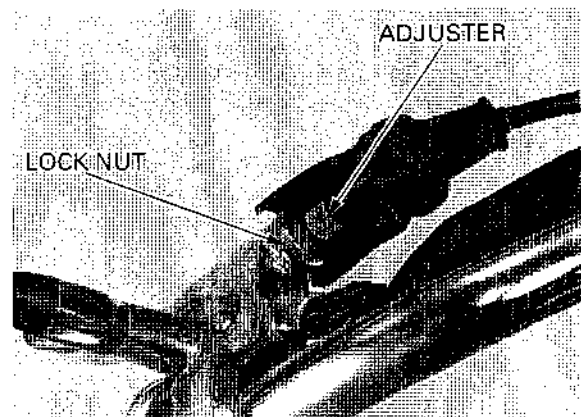
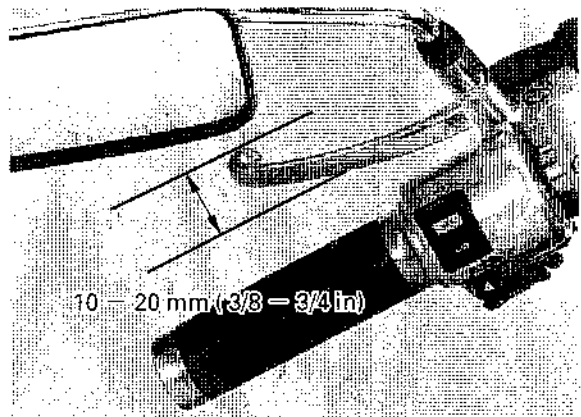

Major adjustments are performed at the clutch arm. Loosen the lock nut and turn the adjusting nut to adjust free play. Hold the adjusting nut securely while tightening the lock nut.

If proper free play cannot be obtained, or the clutch slips during the test ride, disassemble and inspect the clutch (see section 8).

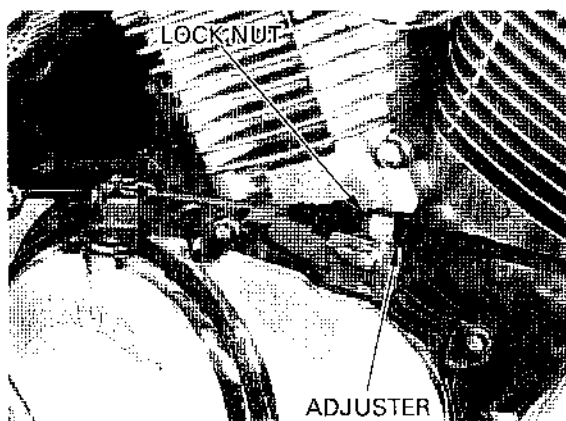

## SIDE STAND

Support the motorcycle on a level surface.

Check the side stand spring for damage or loss of tension.

Check the side stand assembly for freedom of movement and lubricate the side stand pivot if necessary.

Make sure that the side stand is not bent.

Check the side stand ignition cut-off system:

- Sit astride the motorcycle and raise the side stand.
- Start the engine with the transmission in neutral, then shift the transmission into gear, with the clutch lever squeezed.
- Move the side stand fully down.
- The engine should stop as the side stand is lowered.

If there is a problem with the system, check the side stand switch (section 19).

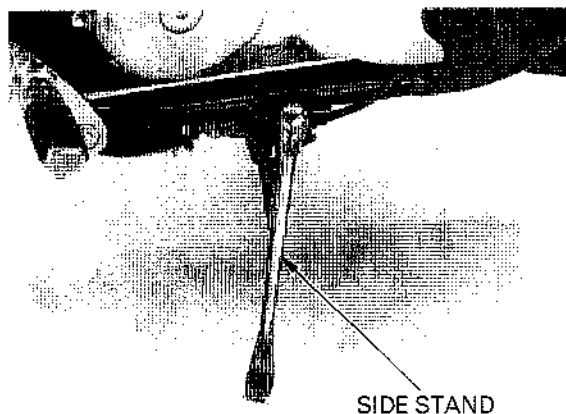

## SUSPENSION

### ▲WARNING

*Loose, worn, or damaged suspension parts impair motorcycle stability and control. Repair or replace any damaged components before riding. Riding a motorcycle with faulty suspension increases your risk of an accident and possible injury.*

### FRONT

Check the action of the forks by operating the front brakes and compressing the front suspension several times.

Check the entire fork assembly for signs of leaks, damage or loose fasteners.

Replace damaged components which cannot be repaired.

Tighten all nuts and bolts.

Refer to section 13 for front fork service.

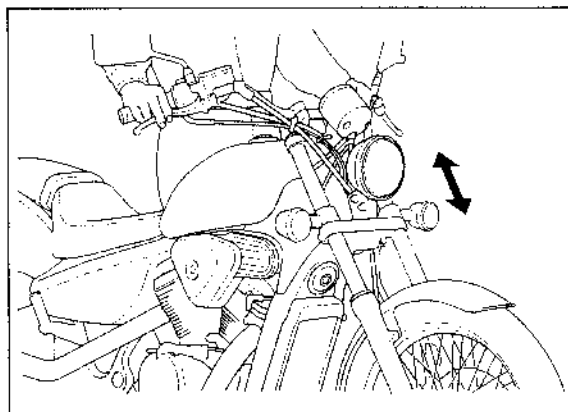

## MAINTENANCE

### REAR

Support the motorcycle securely using safety stand or hoist and raise the rear wheel off the ground.

Check for worn swingarm bearings by grabbing the rear wheel and attempting to move the wheel side to side.

Replace the bearings if any looseness is noted (section 14).

Check the action of the shock absorbers by compressing them several times.

Check the entire shock absorber assembly for signs of leaks, damage or loose fasteners.

Replace damaged components which cannot be repaired.

Tighten all nuts and bolts.

Refer to section 14 for shock absorber service.

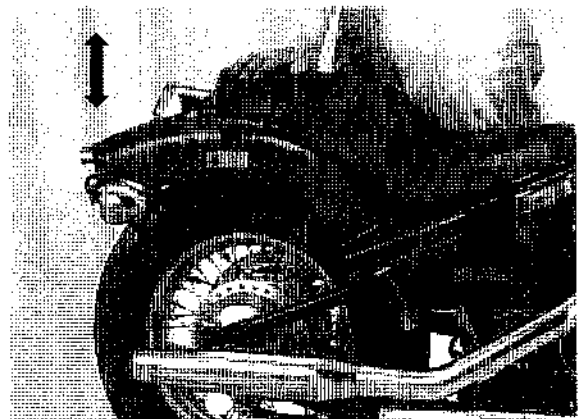
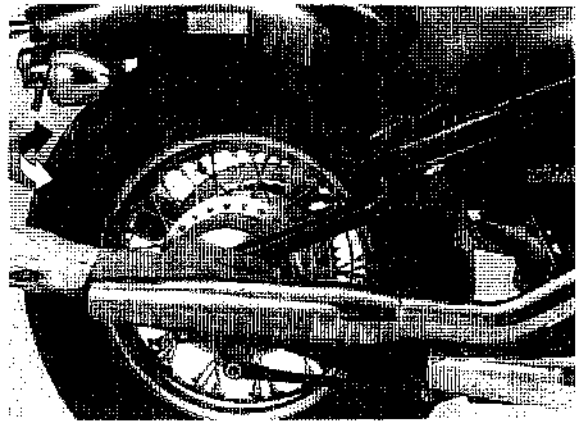

### NUTS, BOLTS, FASTENERS

Check that all chassis nuts, bolts and screws are tightened to their correct torque values (page 1-14) at the interval shown in the Maintenance Schedule (page 3-3).

Check that all cotter pins, slip clips, hose clamps and cable stays are in place and properly secured.

### WHEELS/TIRES

Making sure the fork is not allowed to move, raise the front wheel and check for play. Turn the wheel and check that it rotates smoothly with no unusual noises.

If faults are found, inspect the wheel bearings.

Support the motorcycle securely and raise the rear wheel off the ground.

Check for play in either the wheel or the swingarm pivot. Turn the wheel and check that it rotates smoothly with no unusual noises.

If abnormal conditions are suspected, check the rear wheel bearings.

#### NOTE:

As the swingarm pivot is included in this check, be sure to confirm the location of the play; i.e. from the wheel bearings or the swingarm pivot.

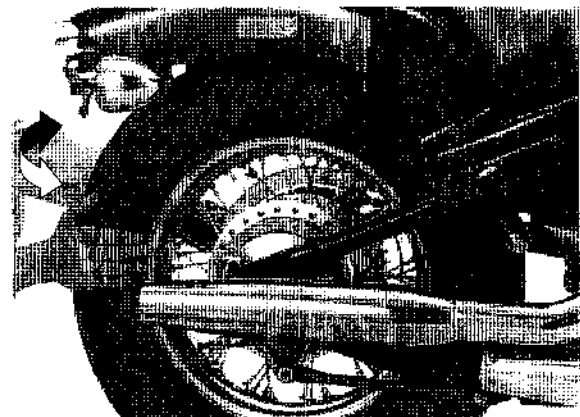

Inspect the spokes for looseness by tapping them with a screwdriver.

*Tap on the spokes and be sure that the clear metallic sound of the same resonant metallic sound can be heard on all spokes.* If a spoke does not have a resonant metallic sound, or if it sounds different from the other spokes, tighten it to the specified torque.

**TOOL:**  
**Spoke wrench** 07JMA – MR60100

**TORQUE:** 4 N·m (0.4 kgf·m , 2.9 lbf·ft)

**NOTE:**

Tire pressure should be checked when tires are COLD.

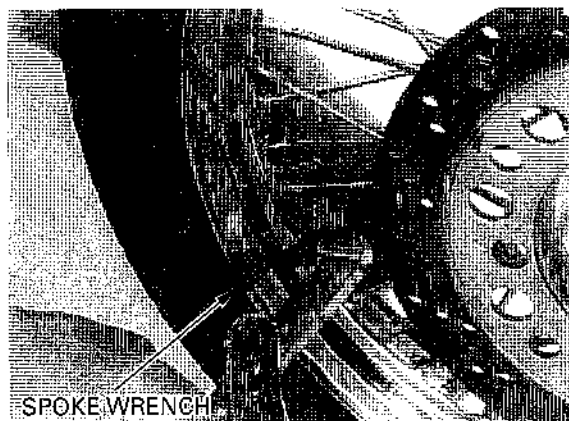

Check the pressure of each tire with a pressure gauge.

**RECOMMENDED TIRE PRESSURE AND SIZE**

Tire size		Front	Rear
		100/90-19 57S	170/80-15 M/C 77S
Cold tire pressures kPa (kgf/cm <sup>2</sup> , psi)	Up to 90 kg (200 lb) load	200 (2.00 , 29)	200 (2.00 , 29)
	Up to maximum weight capacity	200 (2.00 , 29)	250 (2.50 , 36)
Maximum weight capacity		161 kg (355 lbs)	
Tire brand	'97 – '98	BRIDGESTONE L309	BRIDGESTONE G646
		DUNLOP F24	DUNLOP K555
	After '98	DUNLOP F24	DUNLOP D404

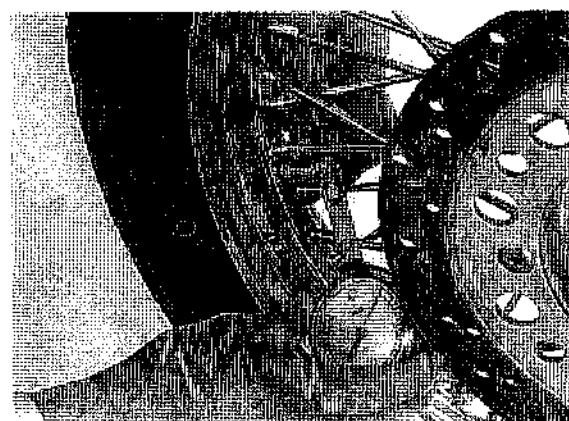

Check the tires for cuts, embedded nails, or other damage.

Check the front and rear wheels for trueness (refer to section 13 and 14).

Measure the tread depth at the center of the tires. Replace the tires when the tread depth reaches the following limits.

**MINIMUM TREAD DEPTH:**

**FRONT:** 1.5 mm (0.06 in)

**REAR:** 2.0 mm (0.08 in)

**STEERING HEAD BEARINGS**

**NOTE:**

Check that the control cables do not interfere with handlebar rotation

Support the motorcycle securely and raise the front wheel off ground check that the handlebar moves freely from side to side. If the handlebar moves unevenly, binds, or has vertical movement, inspect the steering head bearings (section 13).

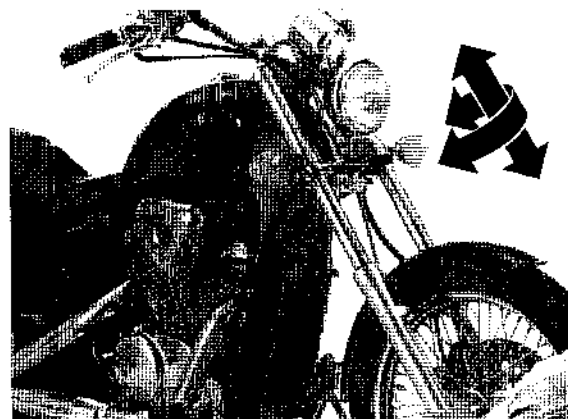
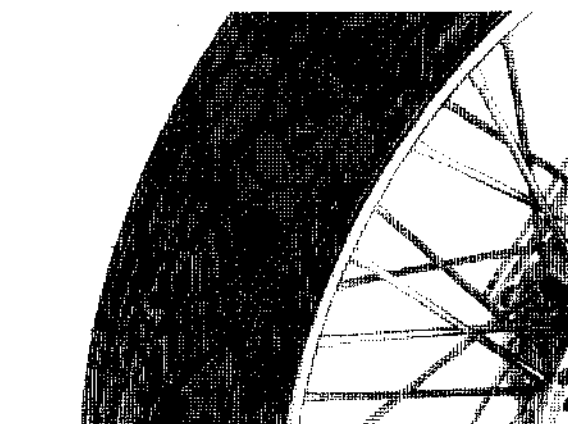

# LUBRICATION SYSTEM

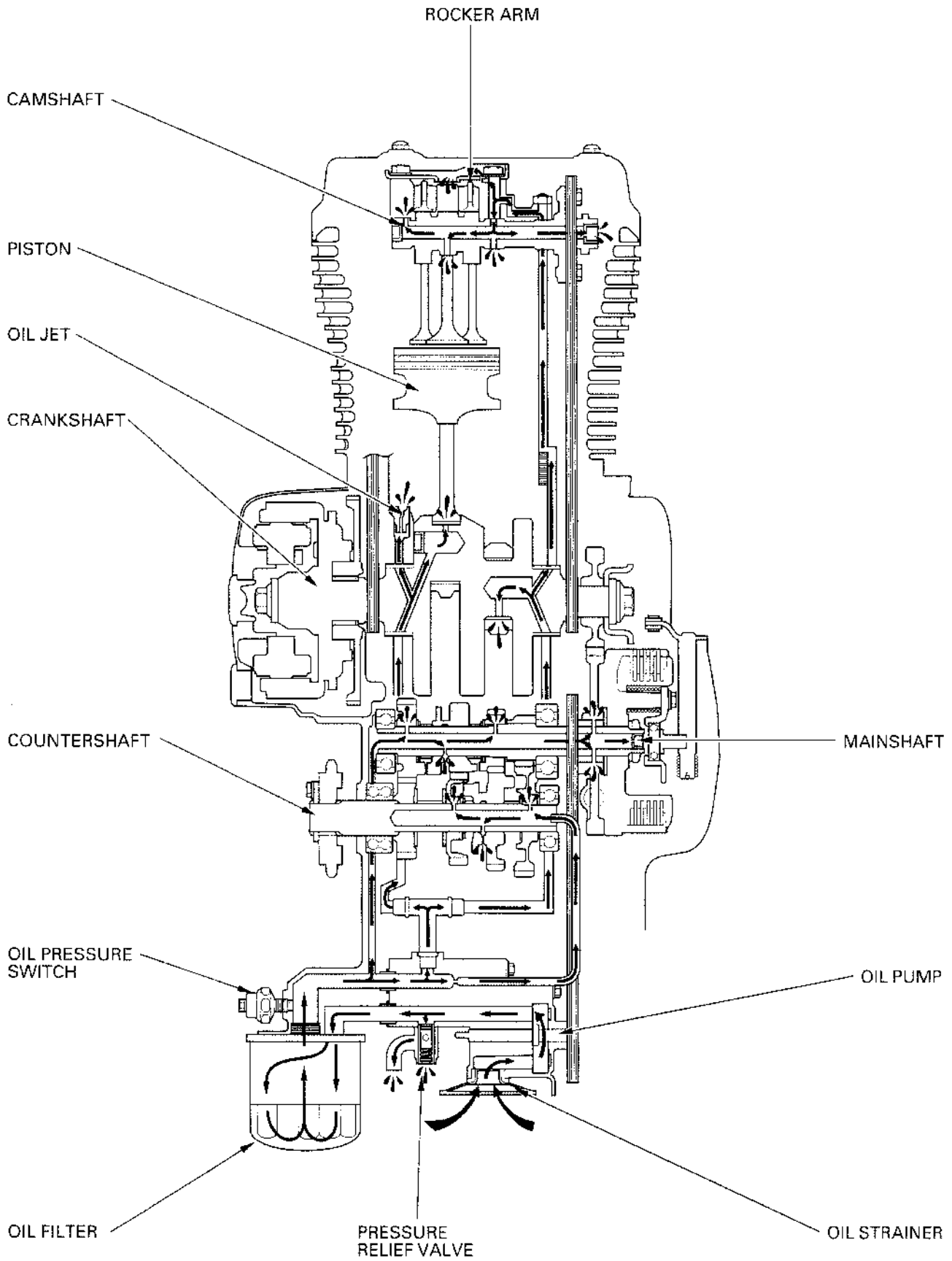



# 4. LUBRICATION SYSTEM

SERVICE INFORMATION	4-1	OIL PRESSURE CHECK	4-3
TROUBLESHOOTING	4-2	OIL PUMP	4-4

## SERVICE INFORMATION

### GENERAL

4

#### ▲WARNING

- *When the engine must be running to do some work, make sure the area is well-ventilated. Never run the engine in an enclosed area. The exhaust contains poisonous carbon monoxide gas that may cause loss of consciousness and lead to death. Run the engine in an open area or with an exhaust evacuation system in an enclosed area.*
- *Used engine oil may cause skin cancer if repeatedly left in contact with the skin for prolonged periods. Although this is unlikely unless you handle used oil on a daily basis, it is still advisable to thoroughly wash your hands with soap and water as soon as possible after handling used oil. KEEP OUT OF REACH OF CHILDREN.*

- The engine must be removed from the frame before servicing the oil pump.
- When removing and installing the oil pump use care not to allow dust or dirt to enter the engine.
- If any portion of the oil pump is worn beyond the specified service limits, replace the oil pump as an assembly.
- After the engine has been installed check that there are no oil leaks and that oil pressure is correct.
- For oil pressure indicator inspection, refer to section 19 of this manual.

### SPECIFICATIONS

Unit: mm (in)

ITEM		STANDARD	SERVICE LIMIT
Engine oil capacity	At draining	2.1 ℓ (2.2 US qt, 1.8 Imp qt)	_____
	At disassembly	2.8 ℓ (3.0 US qt, 2.5 Imp qt)	_____
	At oil filter change	2.25 ℓ (2.38 US qt, 1.98 Imp qt)	_____
Recommended engine oil		HONDA GN4 or HP4 4-stroke oil or equivalent motor oil API service classification SF or SG Viscosity: SAE 10W-40	_____
Oil pressure at oil pressure switch		441 kPa (4.5 kgf/cm <sup>2</sup> , 64 psi) at 6,000 rpm (80 °C/176 °F)	_____
Oil pump rotor	Tip clearance	0.15 (0.006)	0.20 (0.008)
	Body clearance	0.15 - 0.22 (0.006 - 0.009)	0.35 (0.014)
	Side clearance	0.02 - 0.07 (0.001 - 0.003)	0.10 (0.004)

## LUBRICATION SYSTEM

---

### TORQUE VALUES

Oil pump cover bolt	13 N·m (1.3 kgf·m , 9 lbf·ft)	
Oil pump driven sprocket bolt	15 N·m (1.5 kgf·m , 11 lbf·ft)	Apply a locking agent to the threads
Oil filter cartridge	10 N·m (1.0 kgf·m , 7 lbf·ft)	Apply a engine oil to the threads Apply oil to the O-ring
Oil drain bolt	'97 – '98: 34 N·m (3.5 kgf·m , 25 lbf·ft) After '98: 30 N·m (3.1 kgf·m , 22 lbf·ft)	
Oil pressure switch	'97 – '98: 10 N·m (1.0 kgf·m , 7 lbf·ft) After '98: 12 N·m (1.2 kgf·m , 9 lbf·ft)	Apply sealant to the threads
Oil pressure switch cord	2 N·m (0.23 kgf·m , 1.7 lbf·ft)	

### TOOLS

Oil filter wrench	07HAA – PJ70100
Oil pressure gauge	07506 – 3000000
Oil pressure gauge attachment	07510 – 4220100

## TROUBLESHOOTING

#### Oil level low

- Oil consumption
- External oil leak
- Worn piston ring or incorrect piston ring installation
- Worn valve guide or seal

#### Oil contamination (White appearance)

- From coolant mixing with oil
  - Faulty water pump mechanical seal
  - Faulty head gasket
  - Water leak in crankcase

#### No oil pressure

- Oil level too low
- Oil pump drive chain or drive sprocket broken
- Oil pump damaged (pump shaft)
- Internal oil leak

#### Low oil pressure

- Pressure relief valve stuck open
- Clogged oil filter and strainer screen
- Oil pump worn or damaged
- Internal oil leak
- Incorrect oil being used
- Oil level too low

#### High oil pressure

- Pressure relief valve stuck closed
- Plugged oil filter, gallery, or metering orifice
- Incorrect oil being used

#### Seized engine

- No or low oil pressure
- Clogged oil orifice/passage
- Internal oil leak
- Non-recommended oil used

#### Oil contamination

- Deteriorated oil
- Faulty oil filter
- Worn piston ring (White appearance with water or moisture)
  - Damaged water pump mechanical seal
  - Damaged head gasket
  - Oil relief not frequent enough

#### Oil pressure warning indicator does not work

- Faulty oil pressure switch
- Short circuit in the indicator wire
- Low or no oil pressure
- Blown LED

# OIL PRESSURE CHECK

**NOTE:**

If the engine is cold, the pressure reading will be abnormally high. Warm up the engine to normal operating temperature before starting this test.

Warm up the engine.  
 Stop the engine.  
 Remove the left rear cover (page 7-4).

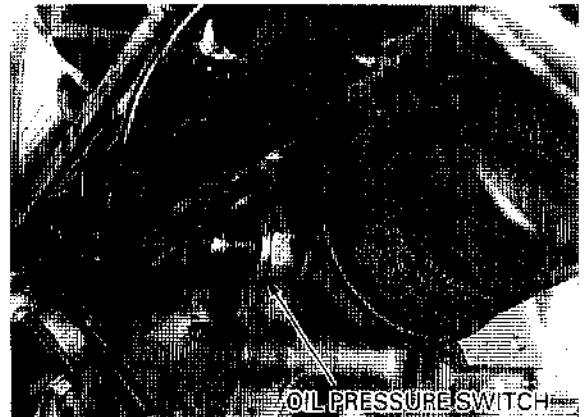

Remove the screw and disconnect the oil pressure switch wire.

Remove the oil pressure switch.  
 Connect the oil pressure gauge attachment and gauge to the pressure switch hole.

**TOOLS:**  
**Oil pressure gauge** 07506-3000000  
**Oil pressure gauge attachment** 07510-4220100

Check the oil level and add the recommended oil if necessary (page 3-14).

Start the engine and check the oil pressure at 6,000 rpm.

**OIL PRESSURE:** 441 kPa (4.5 kgf/cm<sup>2</sup>, 64 psi) at 6,000 rpm (80 °C/176 °F)

Stop the engine and remove the oil pressure gauge attachment and gauge from the pressure switch hole.

Apply sealant to the oil pressure switch threads as shown and tighten it to the specified torque.

**TORQUE:** '97 - '98: 10 N-m (1.0 kgf-m, 7 lbf-ft)  
 After '98: 12 N-m (1.2 kgf-m, 9 lbf-ft)

Connect the oil pressure switch wire and tighten the screw to specified torque.

**TORQUE:** 2 N-m (0.23 kgf-m, 1.7 lbf-ft)

**NOTE:**

Route the oil pressure switch wire correctly (page 1-28).

Start the engine.  
 Check the oil pressure indicator goes out after one or two seconds. If the oil pressure indicator stays on, stop the engine immediately and determine the cause (page 19-8).

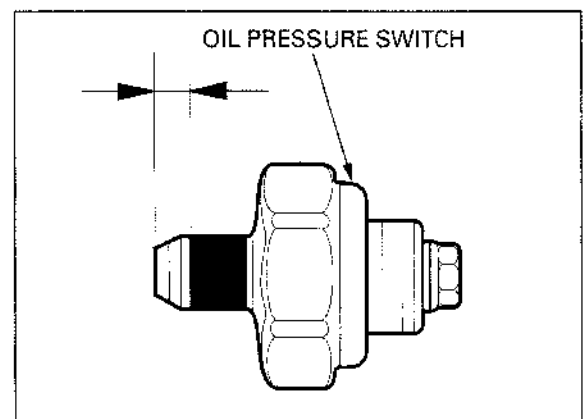
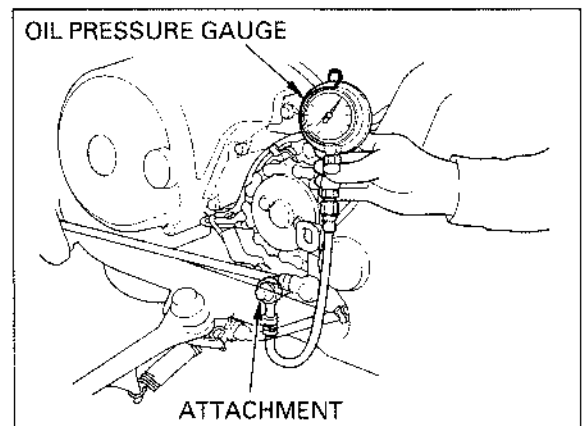
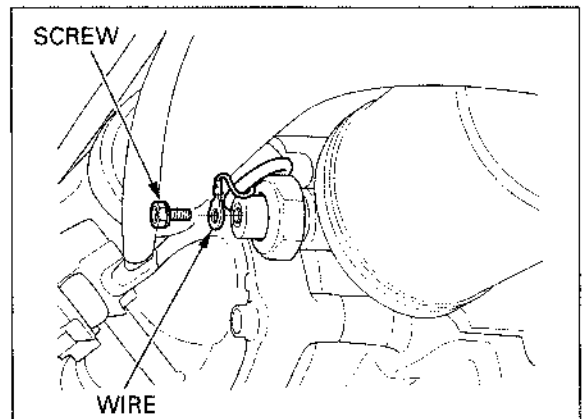

## OIL PUMP

### NOTE:

When removing and installing the oil pump, use care not to allow dust or dirt to enter the engine.

### REMOVAL

Separate the crankcase (page 12-4).

Remove the bolt and oil relief pipe.

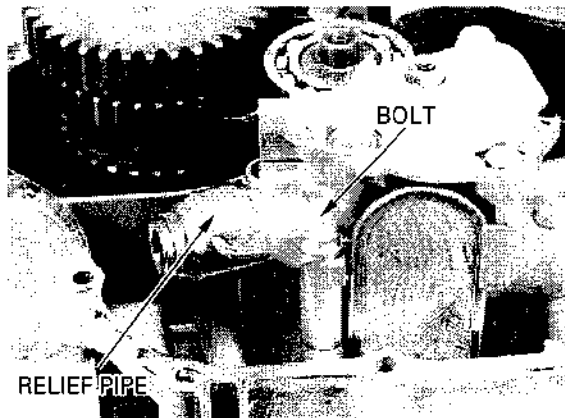

Remove the oil relief valve and O-ring.



Remove the oil pump mounting bolts.

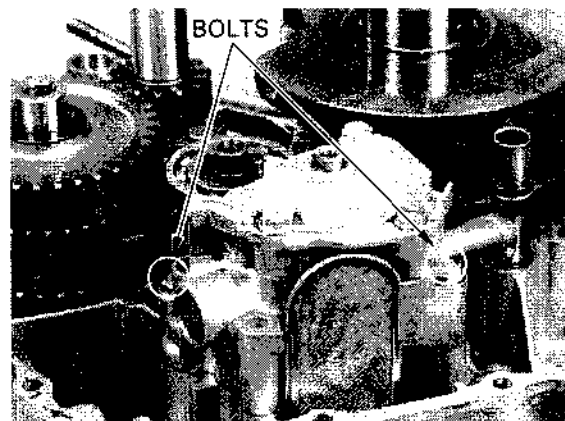

Remove the oil pump.  
Remove the collars and O-rings.  
Remove the dowel pin.

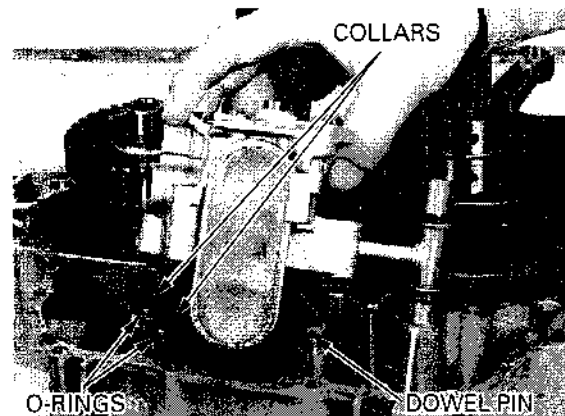

**DISASSEMBLY**

**OIL PUMP DISASSEMBLY**

**NOTE:**

If any portion of the oil pump is worn beyond the specified service limits, replace the oil pump as an assembly.

Remove the oil pipe, oil pipe seals and O-ring.

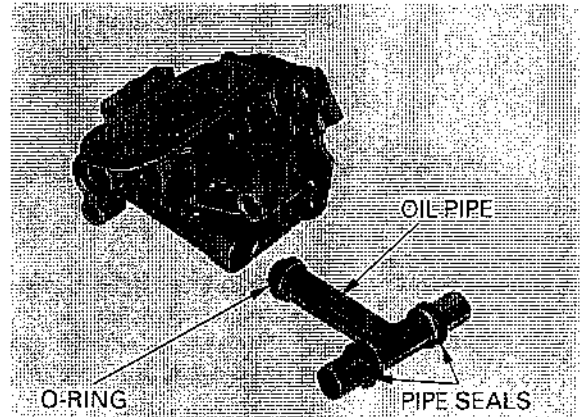

Remove the oil strainer and gasket.

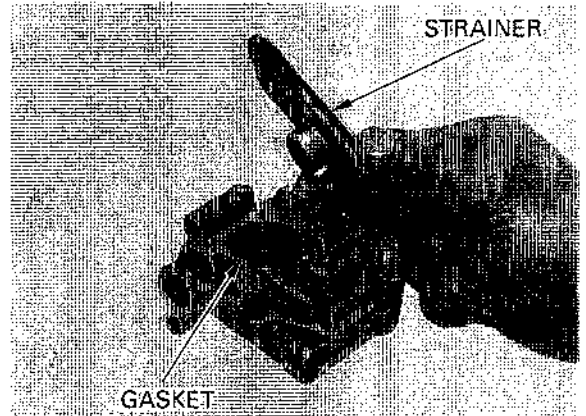

Remove the bolts and pump cover from pump body.

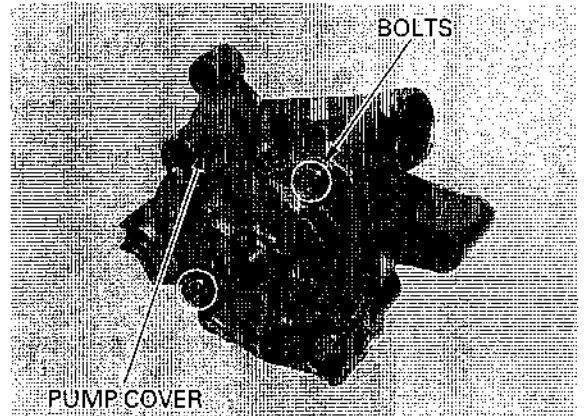

Remove the dowel pins.  
Remove the washer, drive shaft, drive pin, inner rotor and outer rotor.

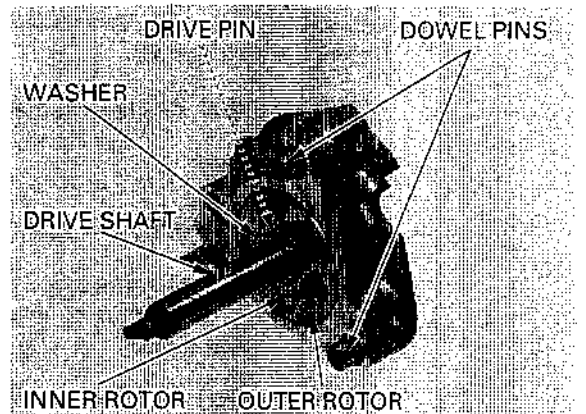

## LUBRICATION SYSTEM

### PRESSURE RELIEF VALVE CHECK

#### **▲WARNING**

*The snap ring is under spring pressure. Use care when removing it and wear eye and face protection.*

Be careful not to lose the disassembled parts.

Check the operation of the pressure relief valve by pushing on the piston.  
Remove the pressure relief valve snap ring and disassemble the pressure relief valve.

Check the piston for wear, sticking or damage.  
Check the valve spring and piston for wear or damage.  
Check the relief valve for clogging or damage.

Clean the remaining parts and assemble the relief valve in the reverse order of disassembly.

SNAP RING



RELIEF VALVE

PISTON

SPRING

WASHER

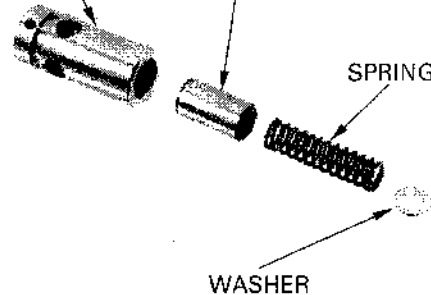

### INSPECTION

#### NOTE:

- Measure at several places and use the largest reading to compare to the service limit.
- If any portion of the oil pump is worn beyond the specified service limits, replace the oil pump as an assembly.

#### BODY CLEARANCE

Install the inner rotor and outer rotor to the pump body.

Install the drive shaft properly.

Measure the pump body-to-outer rotor clearance using the feeler gauge.

**SERVICE LIMIT:** 0.35 mm (0.014 in)

#### TIP CLEARANCE

Install the inner rotor and outer rotor to the pump body.

Install the drive shaft properly.

Measure the outer rotor-to-inner rotor clearance using the feeler gauge.

**SERVICE LIMIT:** 0.20 mm (0.008 in)

#### BODY CLEARANCE

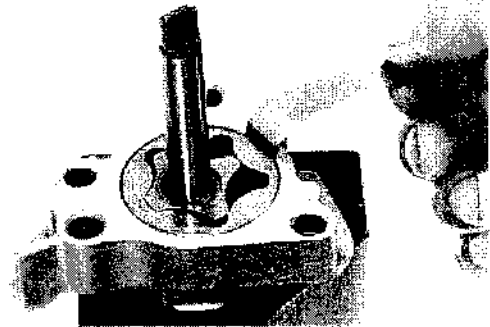

#### TIP CLEARANCE

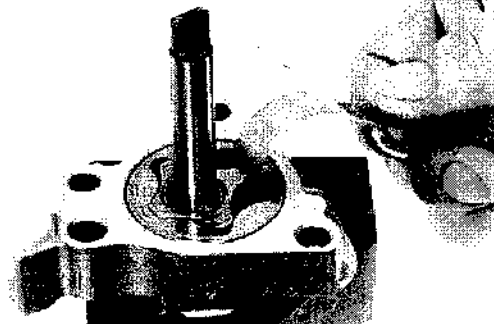

**SIDE CLEARANCE**

Install the inner rotor and outer rotor to the pump body.  
 Measure the rotor side-to-pump body clearance using the feeler gauge and straight edge.

**SERVICE LIMIT:** 0.10 mm (0.004 in)

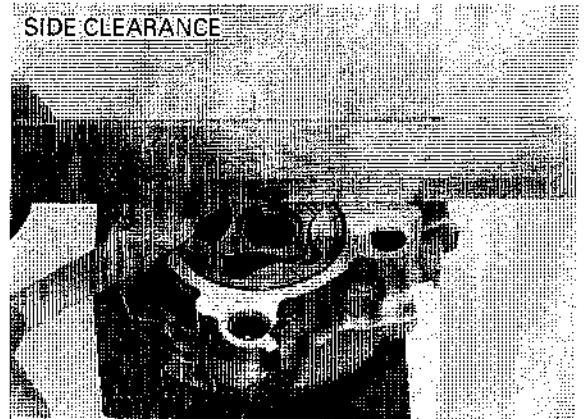

**ASSEMBLY**

**NOTE:**

Before assembly, clean all disassembled parts thoroughly with clean engine oil.

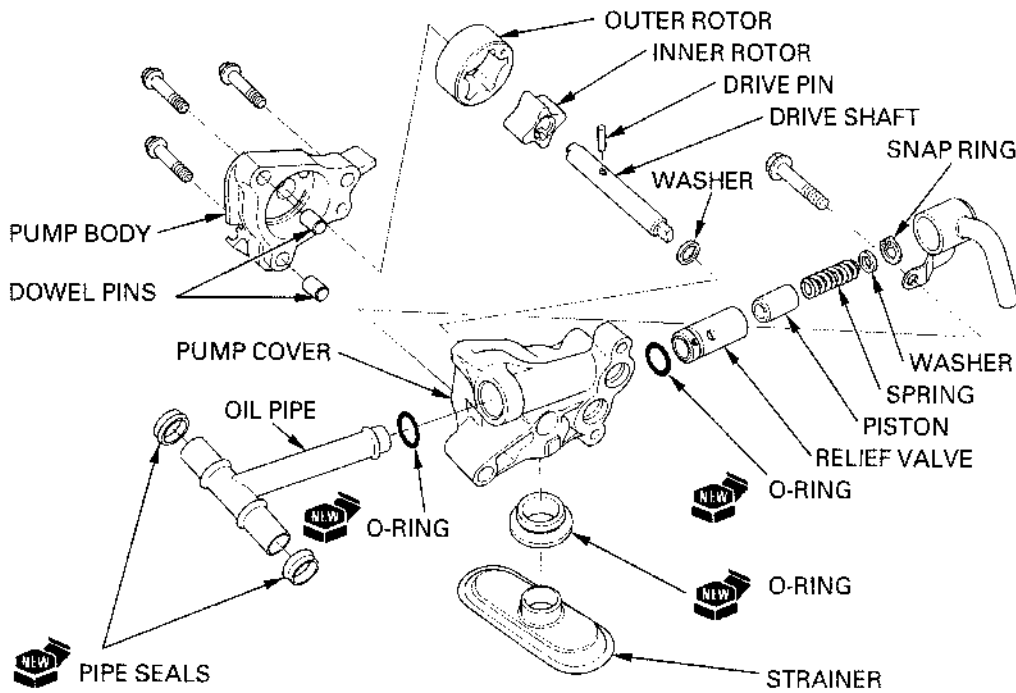

**NOTE:**

When installing the inner rotor, install it with the groove side facing the pump body.

Install the outer rotor and inner rotor to the pump body.

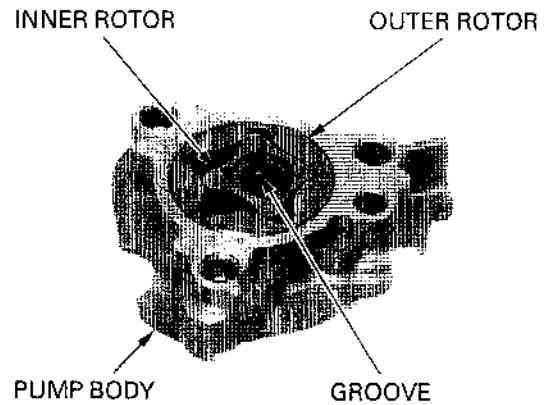

## LUBRICATION SYSTEM

Install the drive shaft and drive pin by aligning the slots in the inner rotor.  
Place the washer into the inner rotor groove.  
Install the dowel pin to the pump cover.

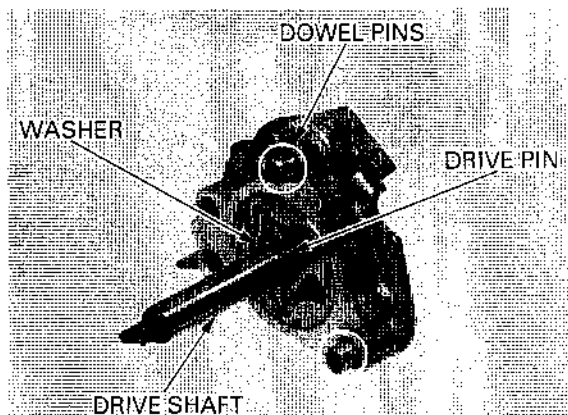

Install the pump body to the pump cover.  
Install and tighten the bolts to the specified torque.

**TORQUE:** 13 N·m (1.3 kgf·m , 9 lbf·ft)

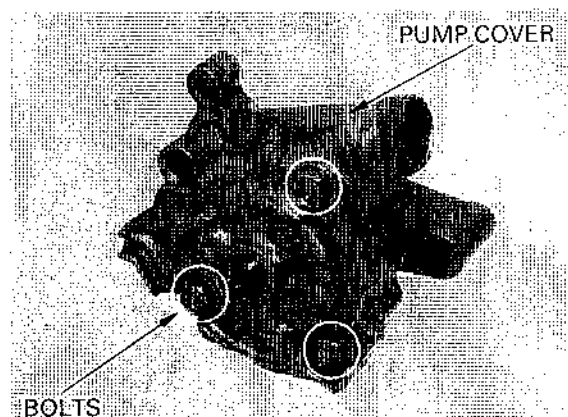

Clean the oil strainer.  
Apply oil to the new O-ring and install the oil strainer.  
Install the oil strainer to the oil pump aligning it to the groove on the oil pump.

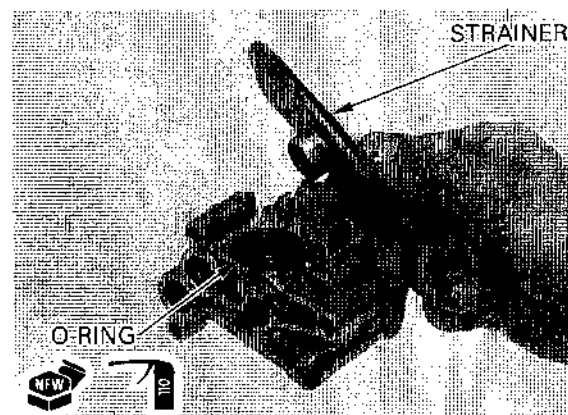

### NOTE:

Install the oil strainer to the pump body groove securely.

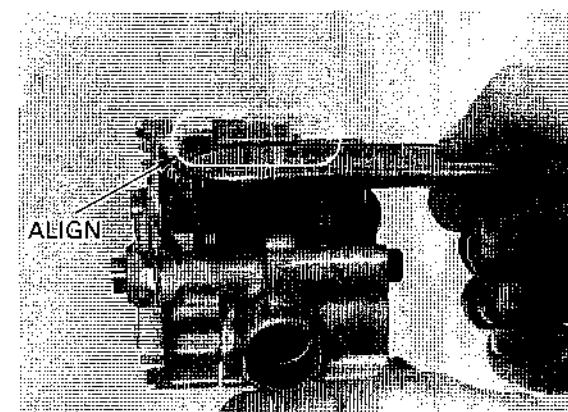



Apply oil to the new oil pipe seal and new O-rings, then install to the oil pipe.

**NOTE:**

Install the O-rings with their tapered side facing out.

Install the oil pipe to the oil pump securely.

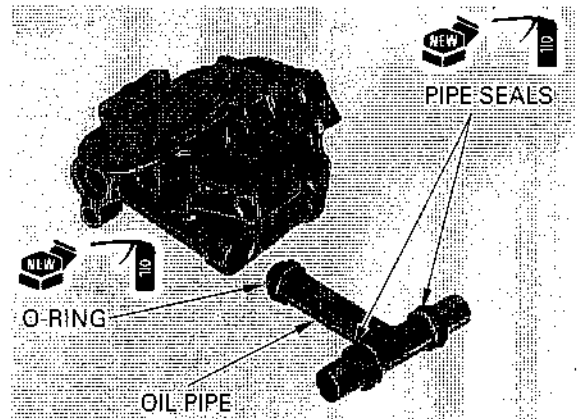

**INSTALLATION**

Install the dowel pin.  
 Install the collars.  
 Apply oil to the new O-rings and install onto the collars.

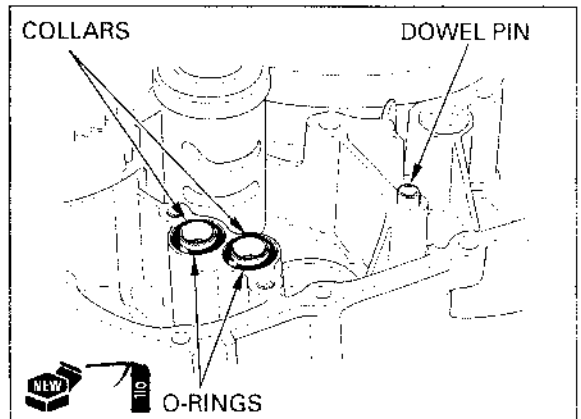

Install the oil pump into the crankcase securely.

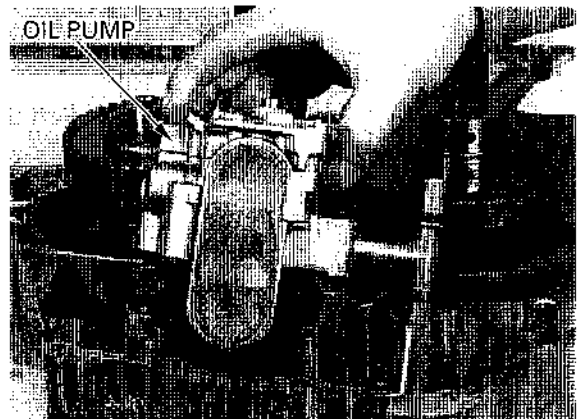

**NOTE:**

Be careful not to damage the O-rings and pipe seals at oil pump installation.

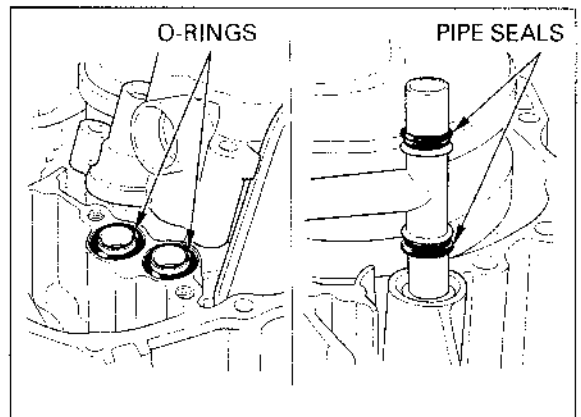

## LUBRICATION SYSTEM

Install and tighten the bolts securely.

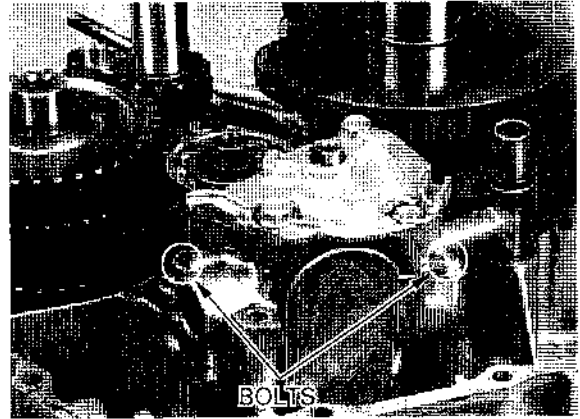

Apply oil to the new O-ring and install the pressure relief valve groove, and install the relief valve to the oil pump.

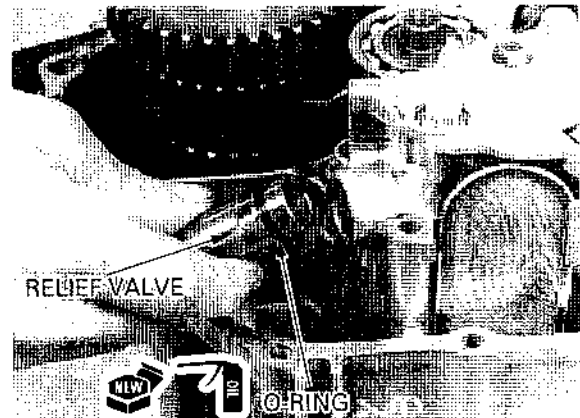

Install the oil relief pipe.  
Install and tighten the bolt securely.

Reassemble the crankcase (page 12-25).  
Check that there are no oil leaks and that oil pressure is correct.

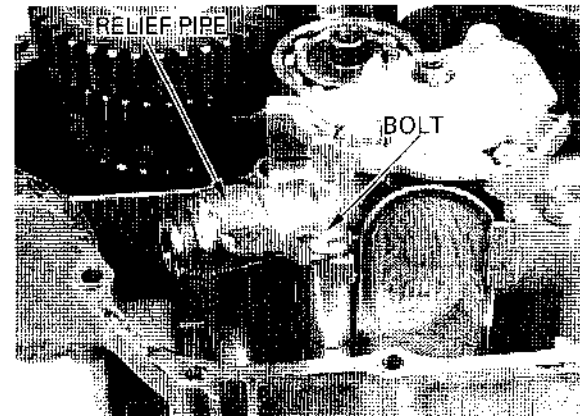

---

**MEMO**

---

# FUEL SYSTEM

'97 - '98:

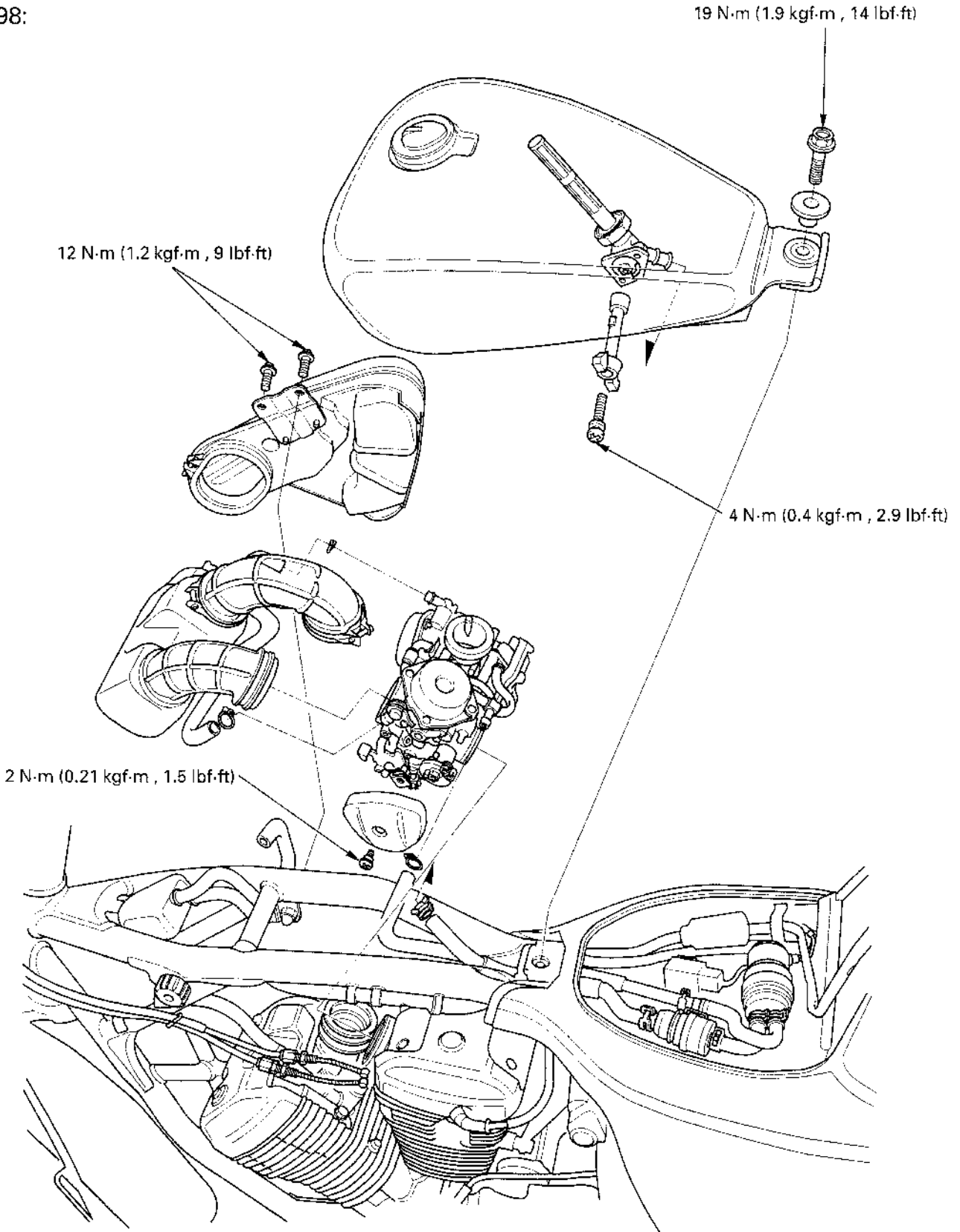

# 5. FUEL SYSTEM

SERVICE INFORMATION	5-2	CARBURETOR INSTALLATION ('97 - '98)	5-26
TROUBLESHOOTING	5-3	CARBURETOR INSTALLATION (After '98)	5-27
AIR CLEANER HOUSING	5-4	PILOT SCREW ADJUSTMENT ('97 - '98)	5-29
SUB-AIR CLEANER ELEMENT ('97 - '98)	5-6	PILOT SCREW ADJUSTMENT (After '98)	5-30
AIR CLEANER CHAMBER	5-7	FUEL PUMP ('97 - '98)	5-32
CARBURETOR REMOVAL ('97 - '98)	5-10	FUEL FILTER ('97 - '98)	5-34
CARBURETOR REMOVAL (After '98)	5-11	FUEL AUTO VALVE (After '98)	5-35
CARBURETOR SEPARATION ('97 - '98)	5-12	HIGH ALTITUDE ADJUSTMENT (U.S.A. ONLY/'97 - '98)	5-37
CARBURETOR DISASSEMBLY/ASSEMBLY	5-13	HIGH ALTITUDE ADJUSTMENT (U.S.A. ONLY/After '98)	5-38
VACUUM CHAMBER	5-15	EVAPORATIVE EMISSION PURGE CONTROL VALVE INSPECTION (CALIFORNIA TYPE ONLY)	5-39
FLOAT CHAMBER	5-17	EVAPORATIVE CARBURETOR AIR VENT CONTROL VALVE INSPECTION (CALIFORNIA TYPE ONLY)	5-41
AIR CUT-OFF VALVE	5-22		
CARBURETOR BODY CLEANING	5-23		
CARBURETOR REASSEMBLY ('97 - '98)	5-24		
CARBURETOR REASSEMBLY (After '98)	5-26		

After '98:

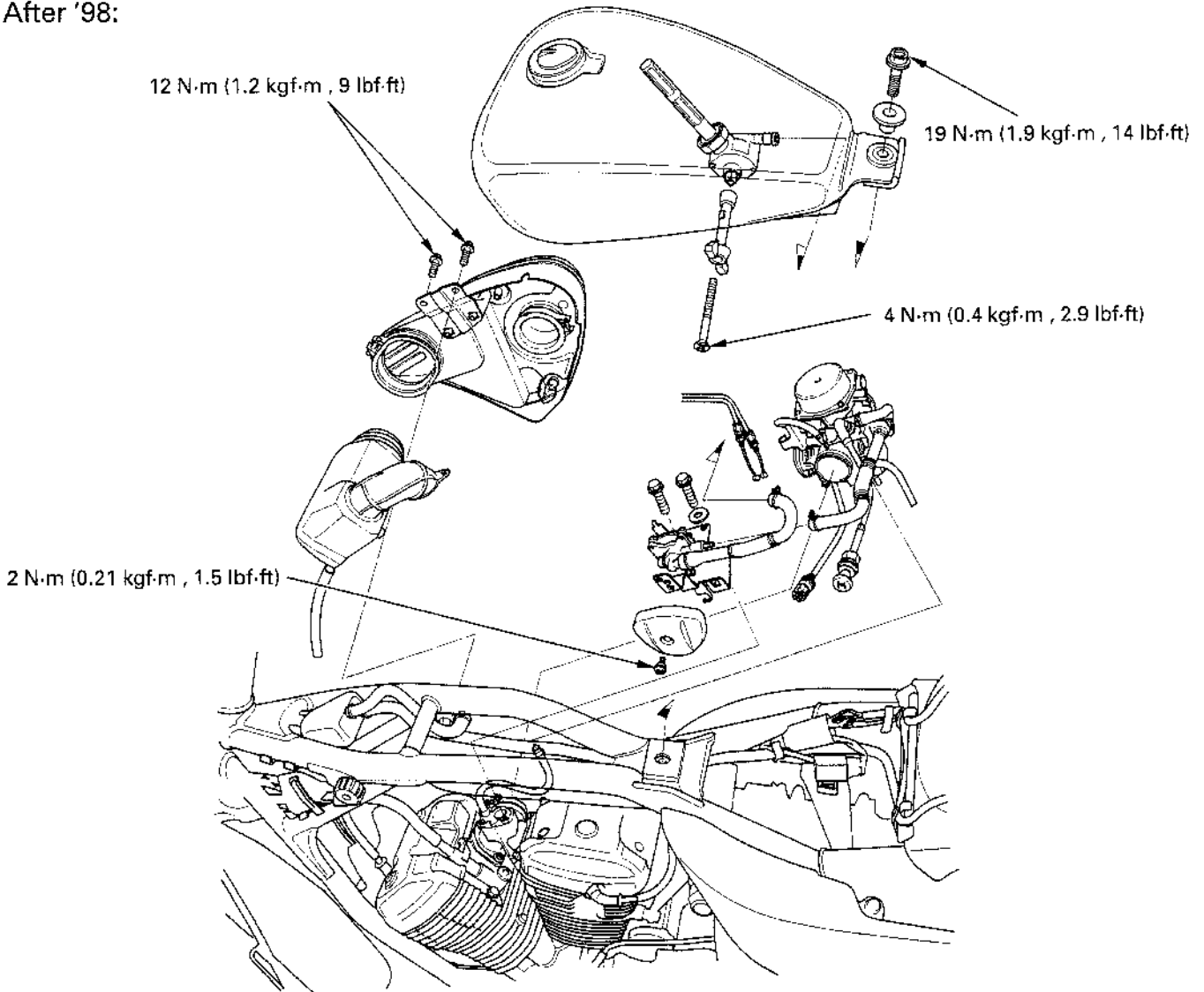

## FUEL SYSTEM

# SERVICE INFORMATION

## GENERAL

### ▲WARNING

- Gasoline is extremely flammable and is explosive under certain conditions. **KEEP OUT OF REACH OF CHILDREN.**
- When the engine must be running to do some work, make sure the area is well-ventilated. Never run the engine in an enclosed area. The exhaust contains poisonous carbon monoxide gas that may cause loss of consciousness and lead to death. Run the engine in an open area or with an exhaust evacuation system in an enclosed area.
- Bending or twisting the control cables will impair smooth operation and could cause the cable to stick or bind, resulting in loss of vehicle control.

- Work in a well ventilated area. Smoking or allowing flames or sparks in the work area or where gasoline is stored can cause a fire or explosion.

### CAUTION:

Be sure to remove the diaphragms before cleaning air and fuel passages with compressed air. The diaphragms might be damaged.

- For fuel tank removal and installation, refer to Section 2.
- Before disassembling the carburetor, place an approved gasoline container under the carburetor drain tube, loosen the carburetor drain screw and drain the carburetor.
- When disassembling the fuel system parts, note the locations of the O-rings. Replace them with new ones on reassembly.
- After removing the carburetor, wrap the intake ports of the engine with a shop towel or cover them with a piece of tape to prevent any foreign material from dropping into the engine. Be sure to remove the cover when reinstalling the carburetor.

### NOTE:

If the vehicle is to be stored for more than one month, drain the float bowls. Fuel left in the float bowls may cause clogged jets resulting in hard starting or poor driveability.

FUEL SYSTEM		STANDARD	
		49 state/Canada type	California type
Carburetor identification number	'97 - '98	VDFDA	VDFEA
	After '98	VE5AC	VE5AB
Main jet	'97 - '98	# 115	
	After '98	# 125	
Slow jet	'97 - '98	# 40	
	After '98	# 45	
Pilot screw	Initial/opening	See page 5-30	
	High altitude adjustment	See page 5-37	
Float level	'97 - '98	7.0 mm (0.28 in)	
	After '98	18.5 mm (0.73 in)	
Base carburetor (for synchronization, '97 - '98 models only)		Rear cylinder (# 1)	
Idle speed		1,200 ± 100 rpm	
Throttle grip free play		2 - 6 mm (1/12 - 1/4 in)	
Fuel pump flow capacity ('97 - '98 models only)		Minimum 800 cm <sup>3</sup> (27.1 US oz, 28.2 Imp oz) per minute at 13V	

**TORQUE VALUES**

Fuel tank mounting bolt		19 N·m (1.9 kgf·m , 14 lbf·ft)
Fuel valve nut	'97 – '98:	23 N·m (2.3 kgf·m , 17 lbf·ft)
	After '98:	35 N·m (3.6 kgf·m , 26 lbf·ft)
Air cleaner housing mounting bolt		12 N·m (1.2 kgf·m , 9 lbf·ft)
Air cleaner housing cover bolt		10 N·m (1.0 kgf·m , 7 lbf·ft)
Fuel valve lever screw		4 N·m (0.4 kgf·m , 2.9 lbf·ft)
Throttle link cover screw		2 N·m (0.21 kgf·m , 1.5 lbf·ft)

**TOOLS**

Carburetor float level gauge	07401-0010000	
Pilot screw wrench	07LMA-MT8010A	After '98 model
	with	
	07PMA-MZ2011A	
Vacuum/Pressure pump	A937X-041-XXXXX or	
Pressure pump	ST-AH-255-MC7 (U.S.A. only)	
Vacuum pump	ST-AH-260-MC7 (U.S.A. only)	

**TROUBLESHOOTING**

**Engine won't to start**

- No fuel in tank
- No fuel to carburetor
  - Fuel strainer clogged
  - Fuel filter clogged
  - Fuel valve stuck
  - Fuel auto cock malfunction (After '98)
  - Fuel line clogged
  - Fuel tank breather clogged
  - Float level faulty
  - Fuel pump malfunction ('97 – '98)
- Too much fuel getting to the engine
  - Air cleaner clogged
  - Flooded carburetor
- Intake air leak
- Fuel contaminated/deteriorated
  - Jet clogged
- Improper starting enrichment valve operation
- Slow circuit or starting enrichment valve circuit clogged
- Improper throttle operation
- No spark at plug (ignition system faulty)

**Lean mixture**

- Fuel jets clogged
- Float valve faulty
- Float level too low
- Fuel line restricted
- Intake air leak
- Throttle valve faulty
- Vacuum piston faulty
- Fuel pump malfunction ('97 – '98)

**Rich mixture**

- Starting enrichment valve open
- Float valve faulty
- Float level too high
- Air jets clogged
- Air cleaner element contaminated
- Flooded carburetor

**Engine stalls, hard to start, rough idling**

- Fuel line restricted
- Ignition system malfunction
- Fuel mixture too lean/rich
- Fuel contaminated/deteriorated
  - Jet clogged
- Intake air leak
- Idle speed misadjusted
- Float level misadjusted
- Fuel tank breather clogged
- Pilot screw misadjusted
- Slow circuit or starting enrichment valve circuit clogged
- Carburetor synchronization misadjusted ('97 – '98)
- Fuel pump malfunction ('97 – '98)
- Fuel auto valve malfunction (After '98)
- Valve clearance misadjusted
- Cylinder compression too low

**Afterburn when engine braking is used**

- Lean mixture in slow circuit
- Air cut-off valve malfunction

**Backfiring or misfiring during acceleration**

- Ignition system malfunction (Section 17)
- Fuel mixture too lean

**Poor performance (driveability) and poor fuel economy**

- Fuel system clogged
- Ignition system malfunction (Section 17)

## AIR CLEANER HOUSING

### REMOVAL ('97 - '98)

Remove the fuel tank (page 2-4).

Remove the air cleaner housing mounting bolts.

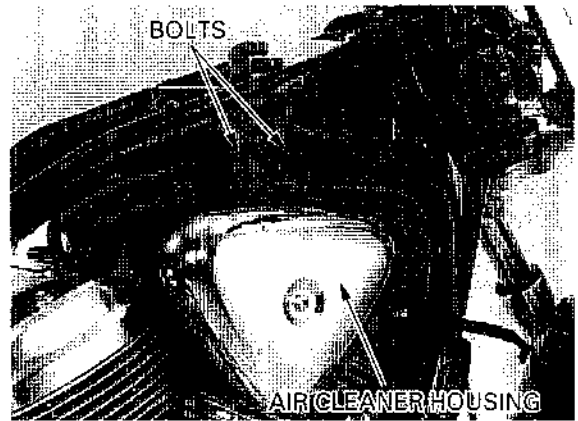

Loosen the air cleaner housing-to-air cleaner chamber band.

Disconnect the crankcase breather tube from the air cleaner housing.

Remove the air cleaner housing.

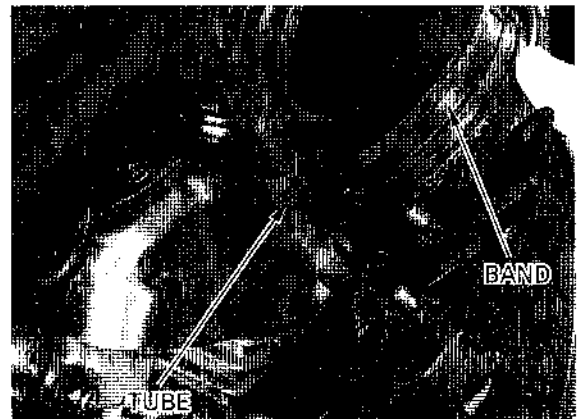

### REMOVAL ('97 - '98)

Loosen the connecting band screws.

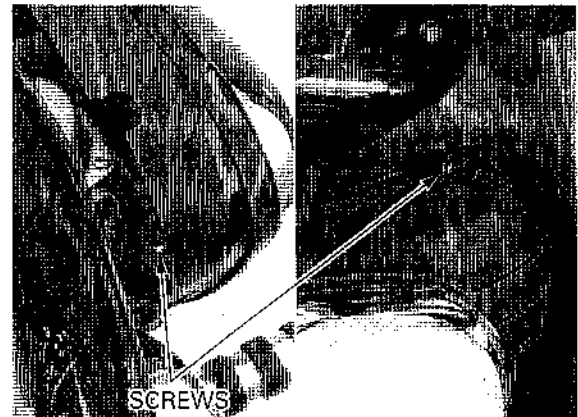

Remove the air cleaner housing mounting bolts.

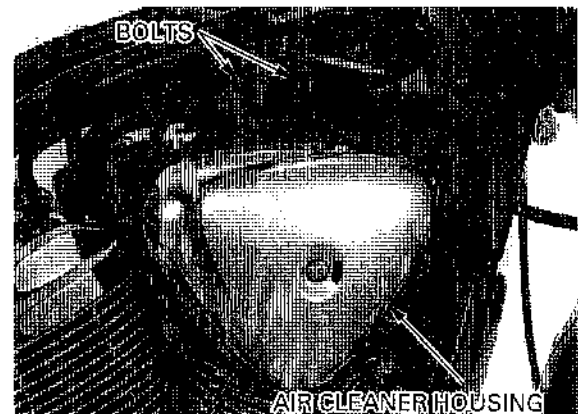



Disconnect the breather tube from the air cleaner housing.

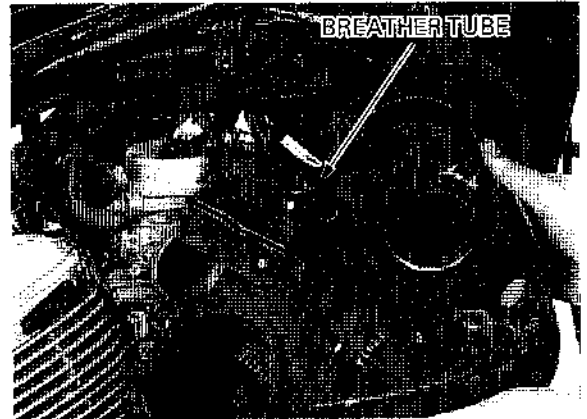

**INSTALLATION ('97 – '98)**

*Route the tubes correctly (page 1-22).*

Wipe clean the mating surfaces and apply a Honda Bond A or equivalent.

Connect the crankcase breather tubes.  
Install the air cleaner housing.  
Tighten the air cleaner housing-to-air cleaner chamber band.



Install and tighten the air cleaner housing mounting bolt to the specified torque.

**TORQUE:** 12 N·m (1.2 kgf·m , 9 lbf·ft)

Install the fuel tank (page 2-7).

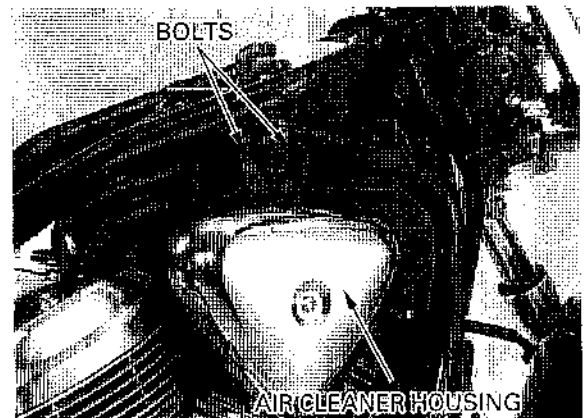

**INSTALLATION (After '98)**

Connect the breather tube to the air cleaner housing.

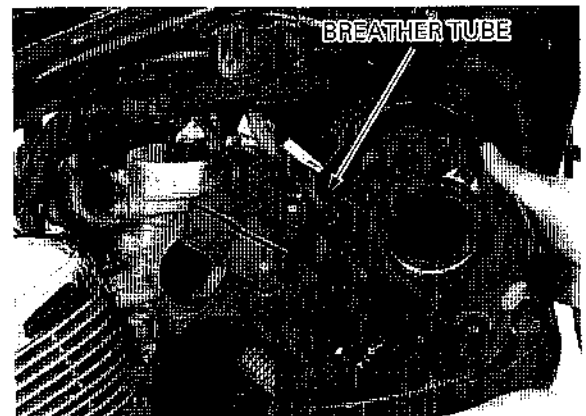

## FUEL SYSTEM

Connect the air cleaner case to the carburetor and air cleaner chamber.  
Install and tighten the air cleaner case mounting bolts to the specified torque.

**TORQUE:** 12 N·m (1.2 kgf·m , 9 lbf·ft)

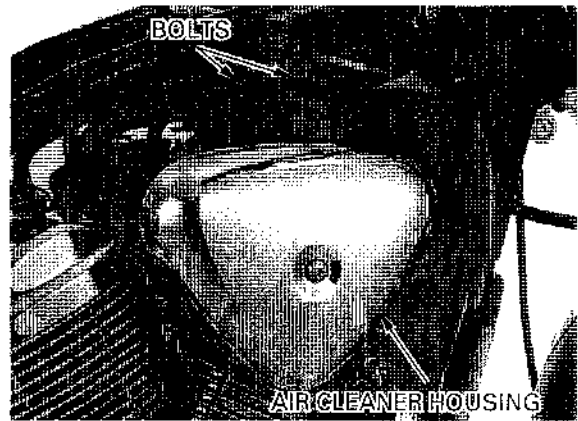

Tighten the connecting band screws (page 5-9).

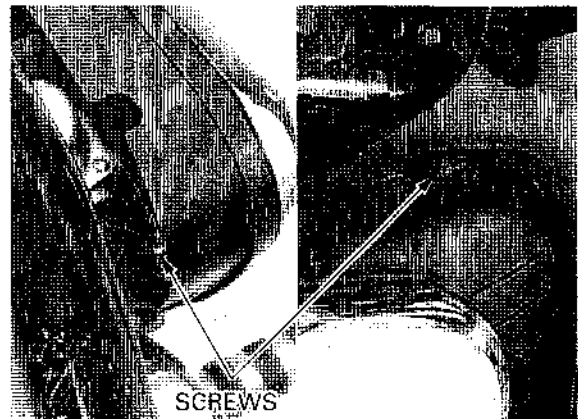

## SUB-AIR CLEANER ELEMENT ('97 — '98)

Remove the air cleaner housing (page 5-4).

Disconnect the air hose (carburetors-to-sub-air cleaner housing cover).

Remove the sub-air cleaner housing cover screw and cover.

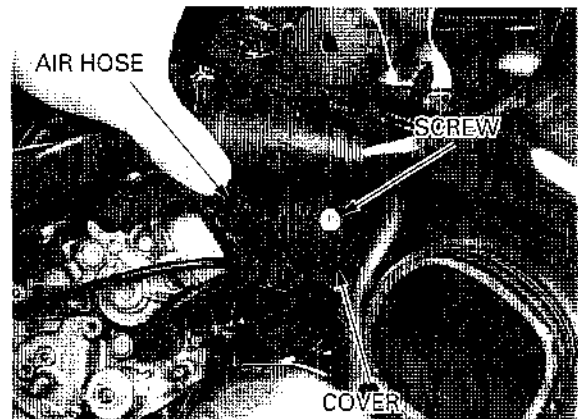

Remove the element.

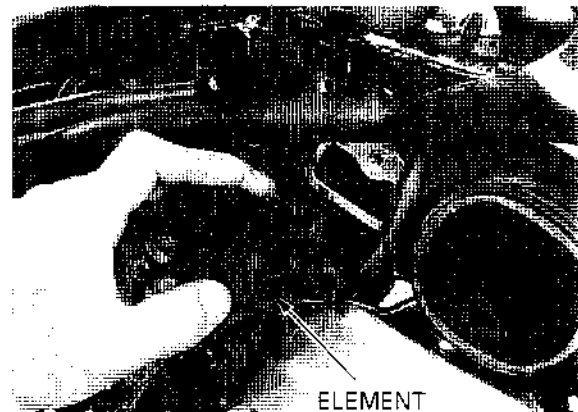

Wash the element in non-flammable or high flash point solvent, squeeze out the solvent thoroughly, and allow the element to dry.

**▲WARNING**

*Never use gasoline or low flash point solvents for cleaning the element. A fire or explosion could result.*

Allow the element to dry thoroughly. Soak the element in gear oil (SAE #80-90) and squeeze out the excess.

Install the element and cover. Install and tighten the mounting screw securely. Connect the air hose from the carburetors.

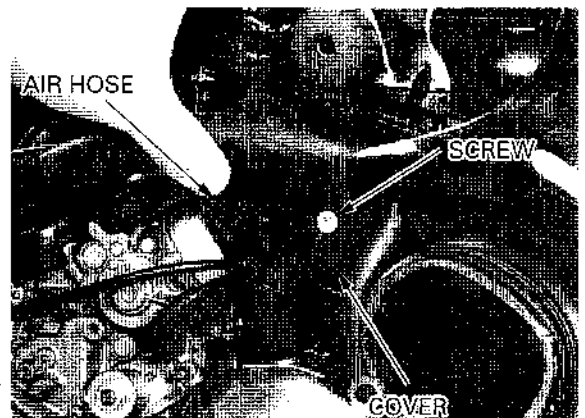
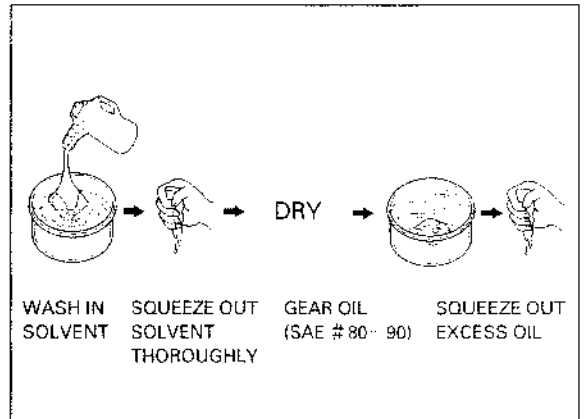

## AIR CLEANER CHAMBER

### REMOVAL ('97 - '98)

Remove the air cleaner housing and sub-air cleaner element (page 5-4, 6).

Loosen the intake duct hose bands at the carburetors and unhook the air cleaner chamber drain tube from the frame.

Remove the air cleaner chamber from the frame.



### REMOVAL (After '98)

Remove the air cleaner housing (page 5-4). Disconnect the spark plug cap (L. front side). Remove the air cleaner chamber from the boss. Remove the air cleaner chamber from the left side of the frame.

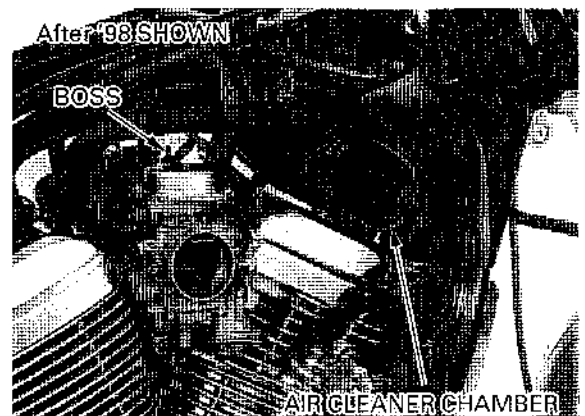

## FUEL SYSTEM

### INSTALLATION ('97 - '98)

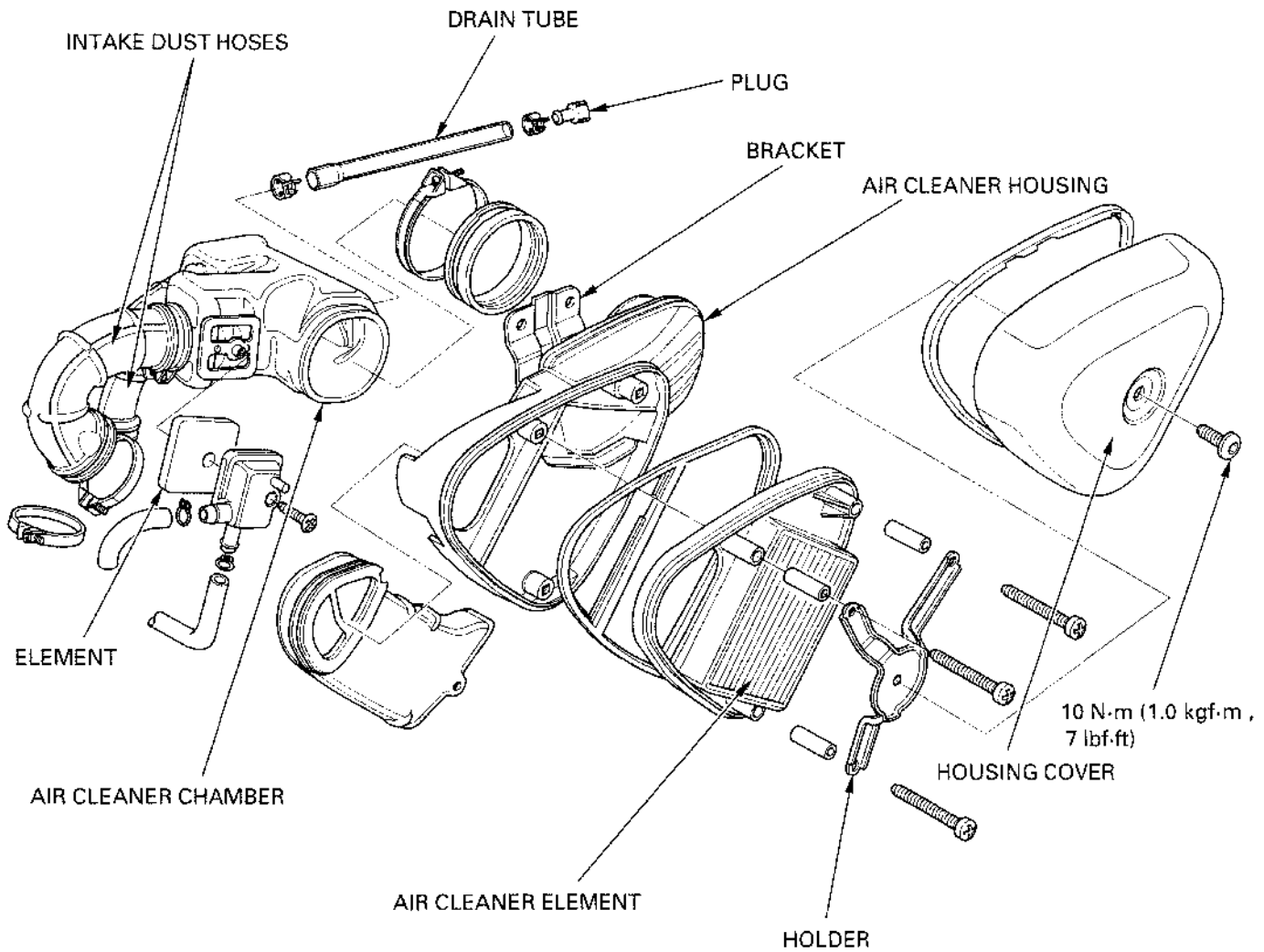

Install the air cleaner chamber in the frame and connect the intake ducts to the carburetors and tighten the band screws.

Install the sub-air cleaner element (page 5-7).  
Install the air cleaner housing (page 5-5).



INSTALLATION (After '98)

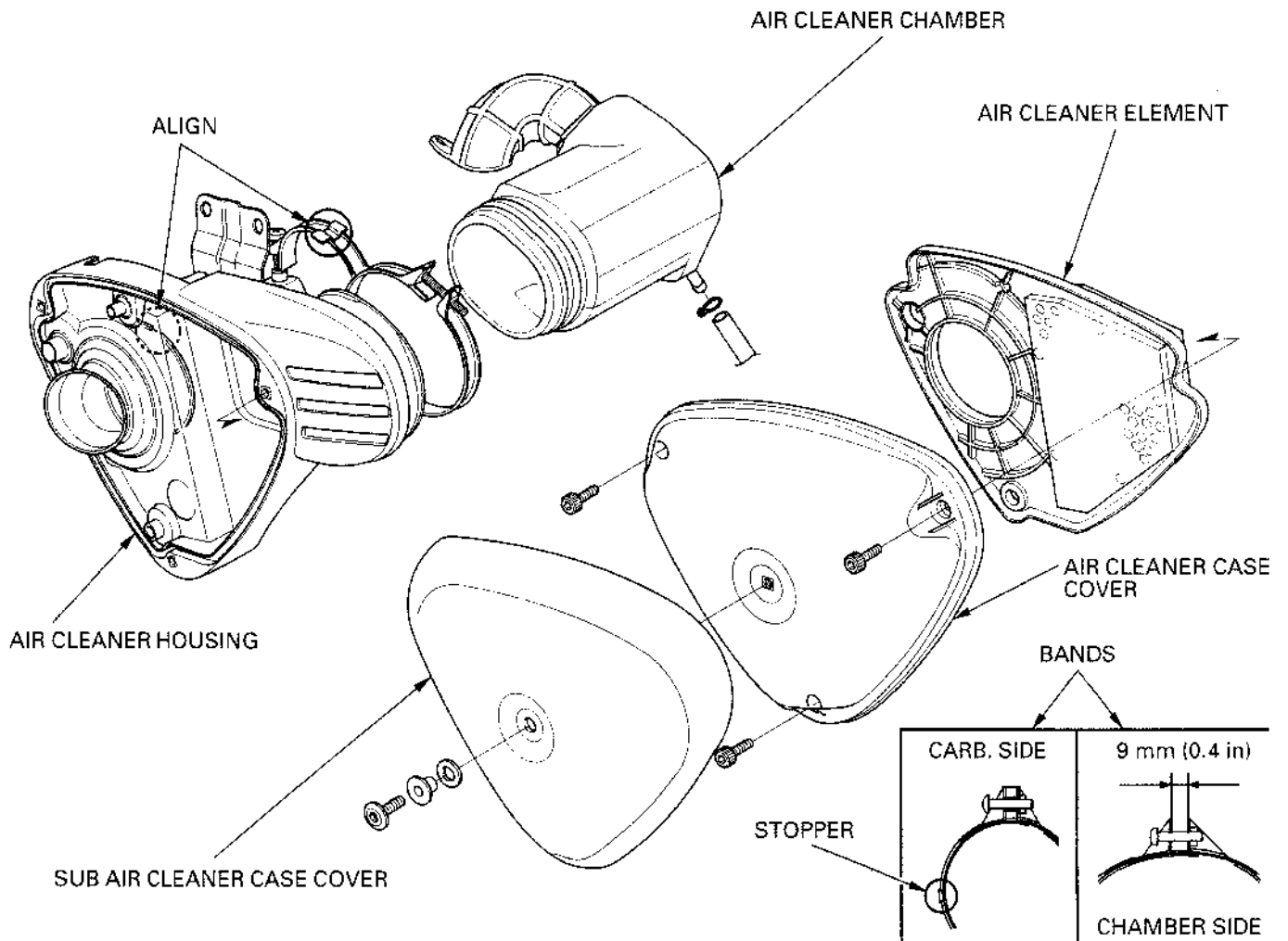

Install the air cleaner chamber from the left side of the frame.  
 Insert the air cleaner chamber to the boss.  
 Connect the spark plug cap (L. front side).  
 Install the air cleaner housing (page 5-4).

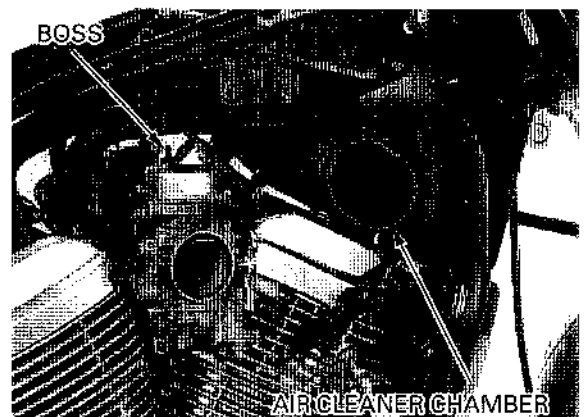

## CARBURETOR REMOVAL ('97 – '98)

**▲WARNING**

*Gasoline is extremely flammable and is explosive under certain conditions. KEEP OUT OF REACH OF CHILDREN.*

Loosen the carburetor drain screw and drain the carburetor.

Remove the air cleaner chamber (page 5-7).  
Remove the throttle link cover and disconnect the throttle cables from the carburetor.

Loosen the carburetor insulator bands.

Disconnect the evaporative emission purge control valve No.5 tubes and evaporative emission carburetor air vent control valve No.6 and 10 tubes from the carburetor (California type only, refer to 1-31).

Pull the carburetors the upward and out of the engine.

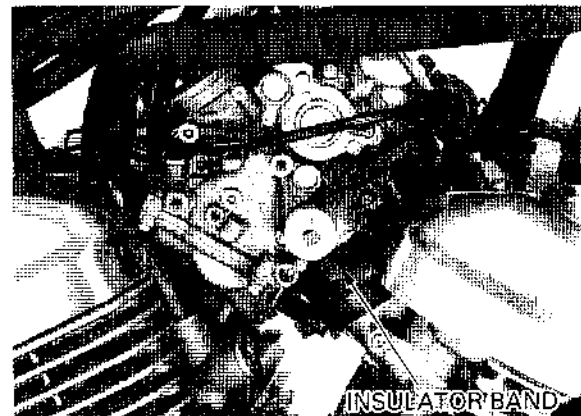
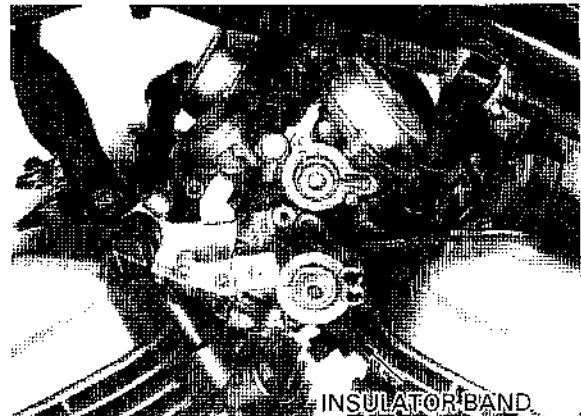
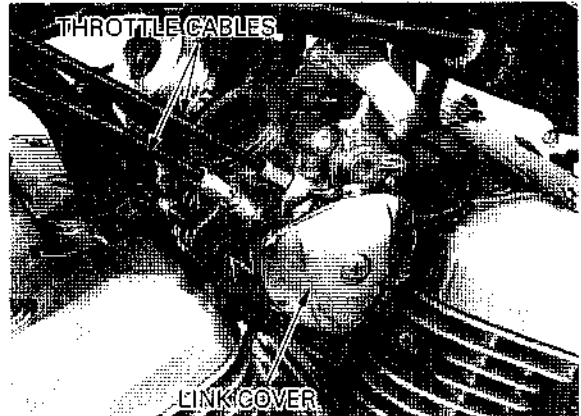

Remove the starting enrichment (SE) valve cable and SE valve from the carburetor by loosening each lock nut.

Remove the air tubes (carburetors-to-air cleaner), and fuel tube from the carburetor.

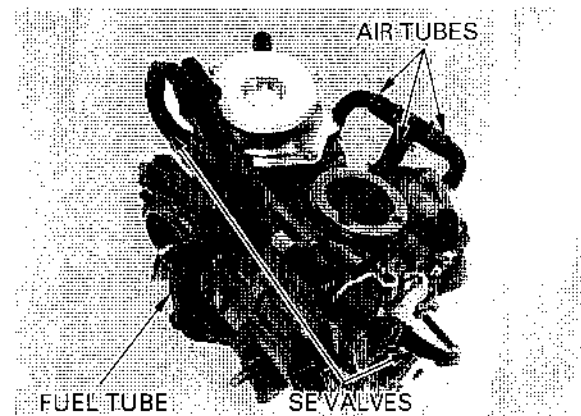

## CARBURETOR REMOVAL (After '98)

**▲WARNING**

*Gasoline is extremely flammable and is explosive under certain conditions. KEEP OUT OF REACH OF CHILDREN.*

Loosen the carburetor drain screw and drain the fuel from the float chamber.  
 Remove the fuel tank (page 2-4).  
 Remove the link cover (page 5-35).  
 Loosen the nut and remove the choke knob.  
 Remove the throttle stop control knob.

Disconnect the fuel tube.  
 Disconnect the following tubes from the EVAP CAV CONTROL VALVE (California type only).

- No. 6 tube - See page 1-37
- No. 10 tube - Vacuum hose routing diagram/After '98

Disconnect the water tube from the inlet manifold.  
 Disconnect the No. 5 tube (California type only/ After '98: page 1-37).

Loosen the throttle cable adjusters.

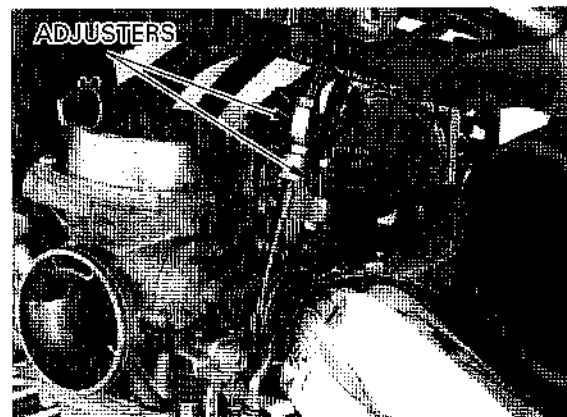
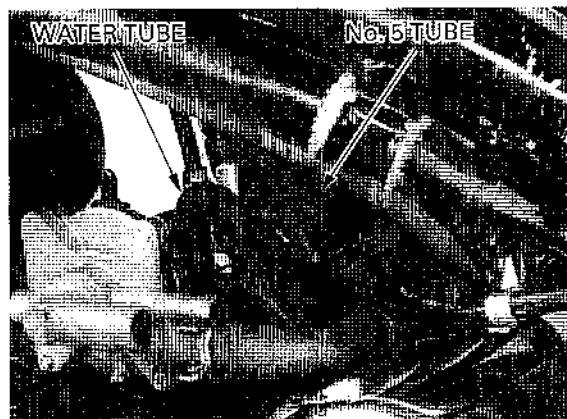
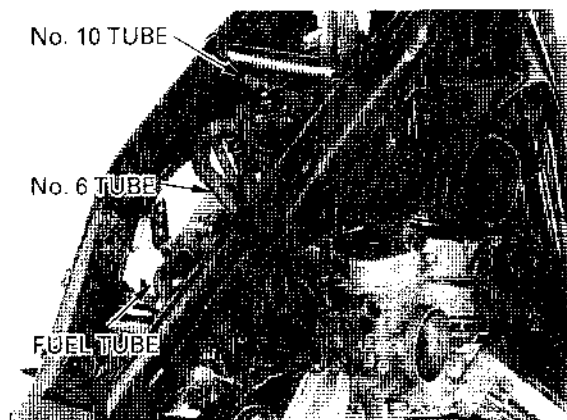
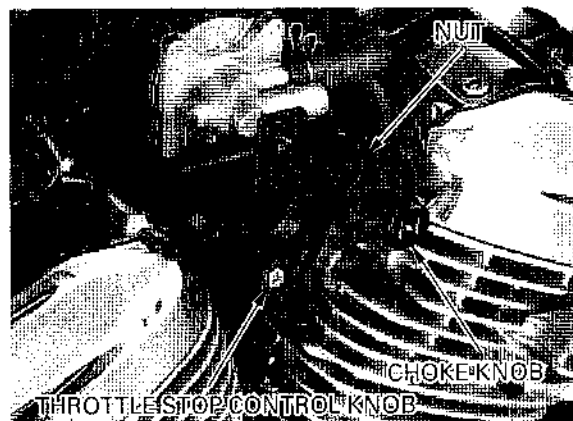

## FUEL SYSTEM

Loosen the carburetor insulator band screws and disconnect the carburetor.

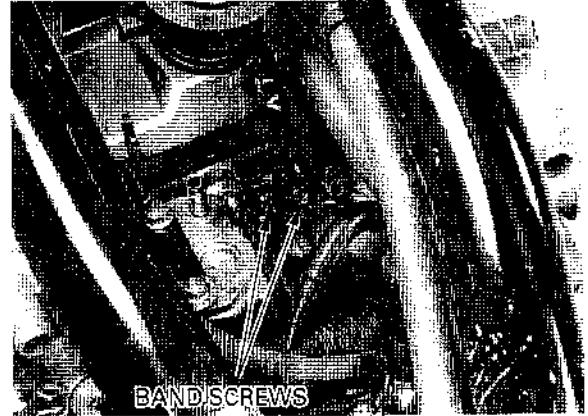

Disconnect the water tubes.  
Disconnect the No. 11 tube (California type only/  
After '98: page 1-37).

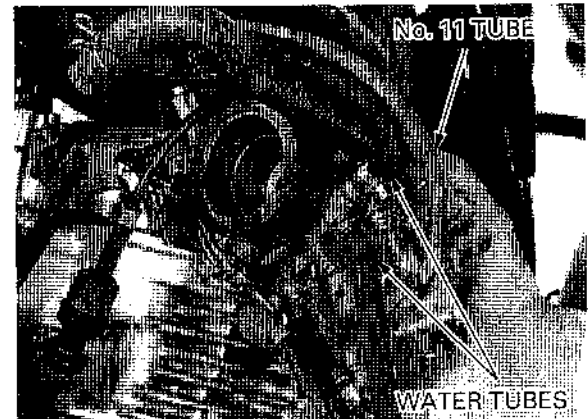

Remove the adjusters from the stay.  
Remove the throttle cables from the throttle drum.



## CARBURETOR SEPARATION ('97 — '98)

*The vacuum chamber, float chamber and jets can be serviced without separating the carburetors. When separating the carburetors, be careful not to lose the thrust spring and synchronization adjusting spring.*

Loosen the synchronization adjusting screw.

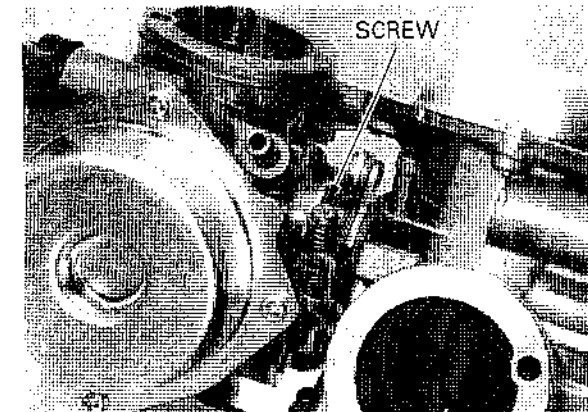



Separate the carburetors by removing the two attaching screws.

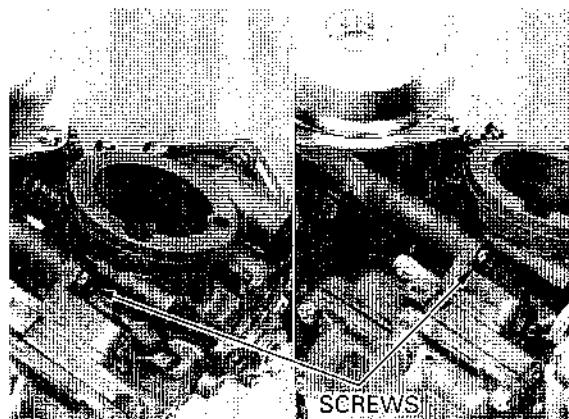

Remove the thrust spring.

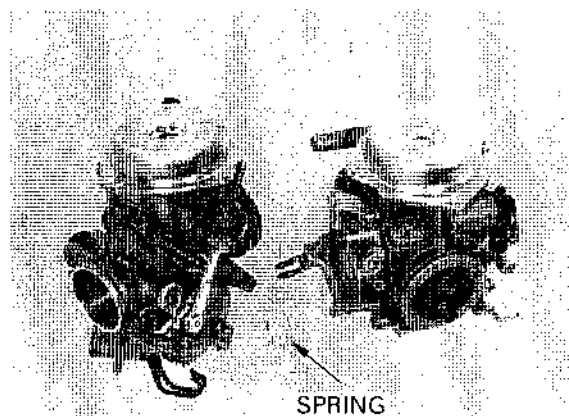

## CARBURETOR DISASSEMBLY/ ASSEMBLY

**NOTE:**

- Vacuum chamber, float chamber and jets can be serviced without separating the carburetors.
- Note the location of the each carburetor parts so they can be put back into the original location.
- Keep each carburetor's parts separate from the others so you can install the parts in their original positions.
- For the following component inspections refer to the applicable pages.
  - Vacuum chamber (page 5-15)
  - Float chamber ('97-'98: page 5-17)  
(After '98: page 5-19)
  - Pilot screw (page 5-20)
  - Jets (page 5-20)

# FUEL SYSTEM

'97 - '98:

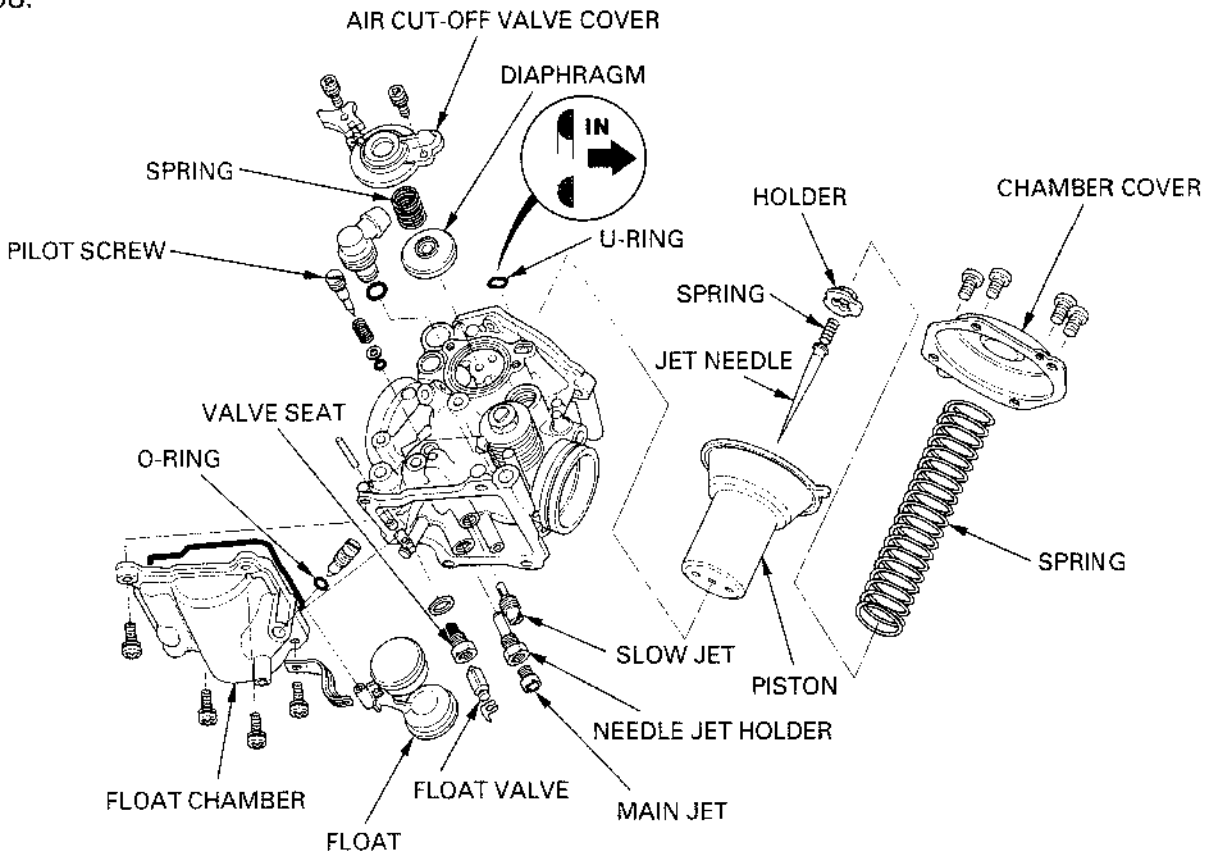

After '98

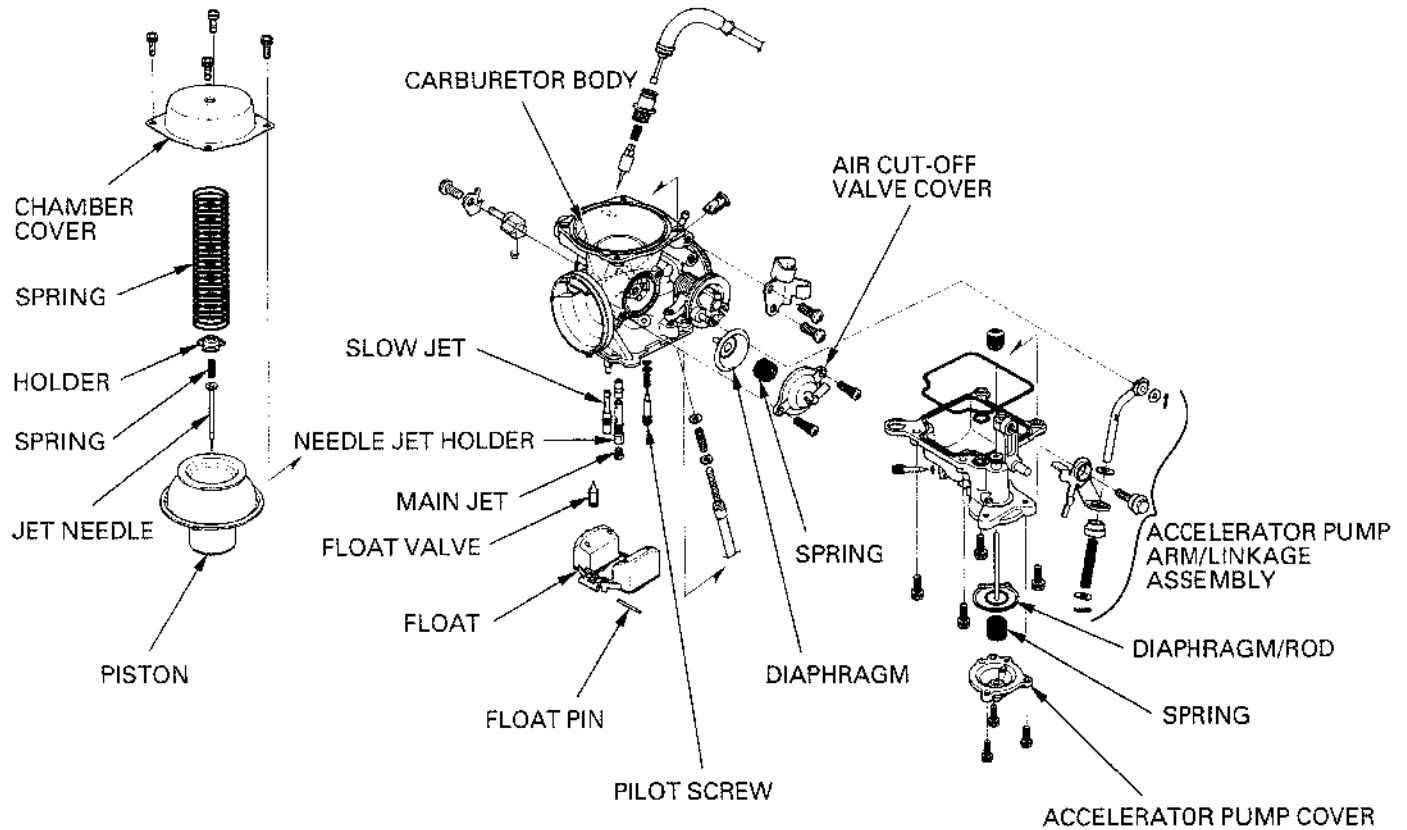

## VACUUM CHAMBER

### DISASSEMBLY

Remove the four screws and vacuum chamber cover.

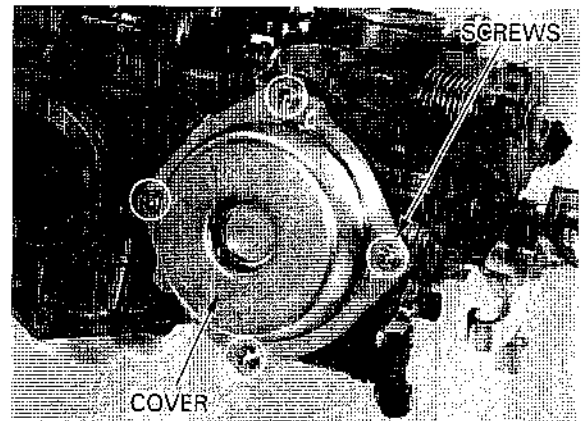

Remove the spring, and diaphragm/vacuum piston.

Inspect the vacuum piston for wear, nicks, scratches or other damage.

Make sure the piston moves up and down freely in the chamber.

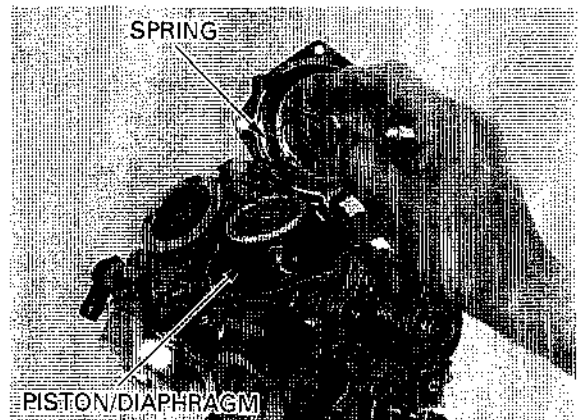

Push the jet needle holder in and turn it in 90 degrees counterclockwise.

**CAUTION:**

*Be careful not to damage the diaphragm.*

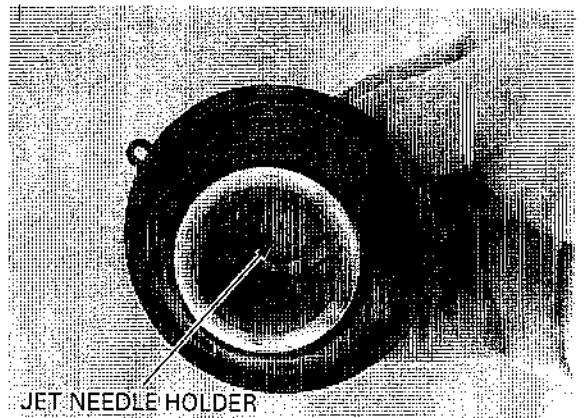

Remove the jet needle holder, spring and jet needle from the piston.

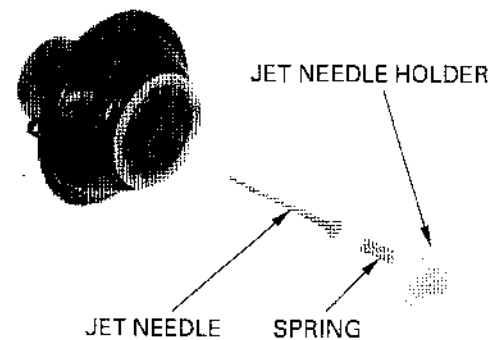

## INSPECTION

Inspect the needle for excessive wear at the tip, bending or other damage.

Inspect the diaphragm for damage, fatigue or pin holes.

Inspect the vacuum piston for wear or damage.

Replace these parts if necessary.

Air will leak out of the vacuum chamber if the diaphragm is damaged in any way-even a pin hole.

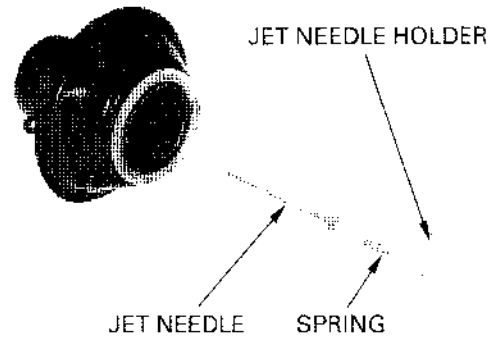

## ASSEMBLY

Install the jet needle, spring and jet needle holder to the vacuum piston.

Push the jet needle holder in and turn it in 90 degrees clockwise.

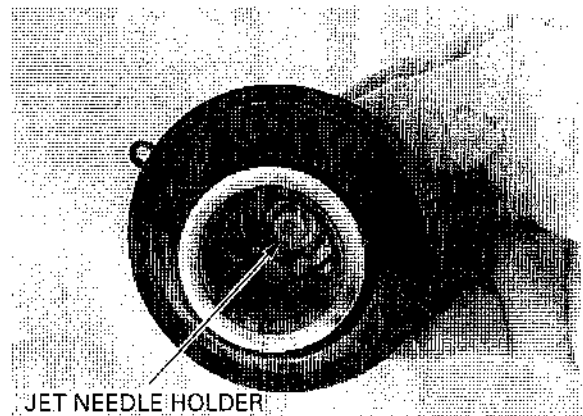

Install the vacuum piston/diaphragm to the cavity. Lift the bottom of the vacuum piston with your finger to set the diaphragm lip in the carburetor body.

### NOTE:

Align the tab of the diaphragm with the cavity.

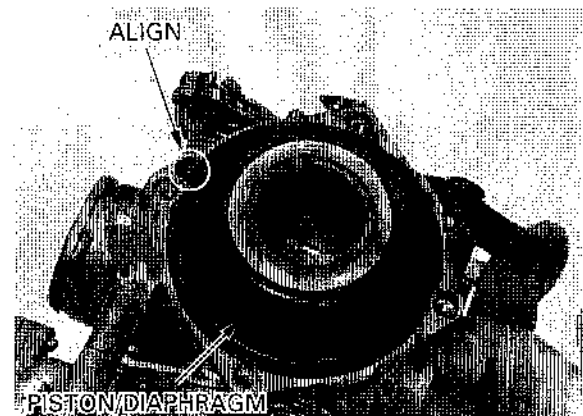

### NOTE:

Be careful not to pinch the diaphragm, and to keep the spring straight when installing the chamber cover by compressing the spring.

Install the spring and chamber cover while the piston remains in place. Secure the cover with screws before releasing the vacuum piston.

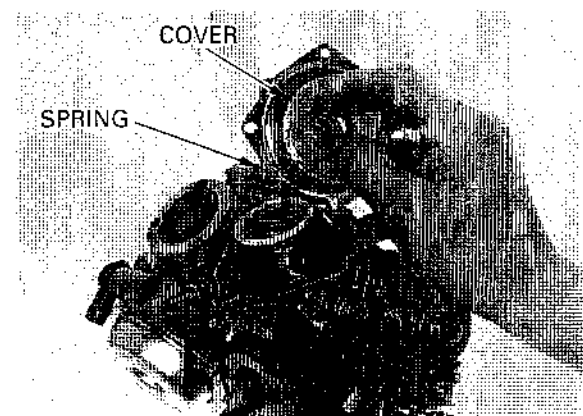

Install and tighten the screws securely.

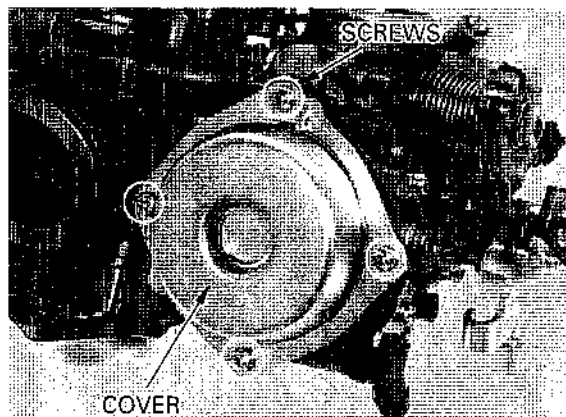

## FLOAT CHAMBER

### DISASSEMBLY ('97 - '98)

Remove the screws, float chamber and O-ring.

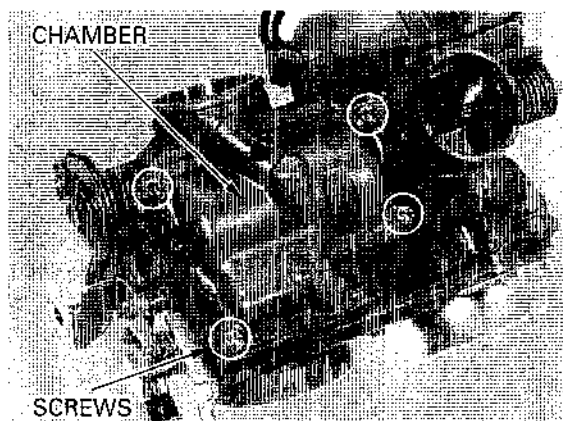

Remove the float pin, float and float valve.

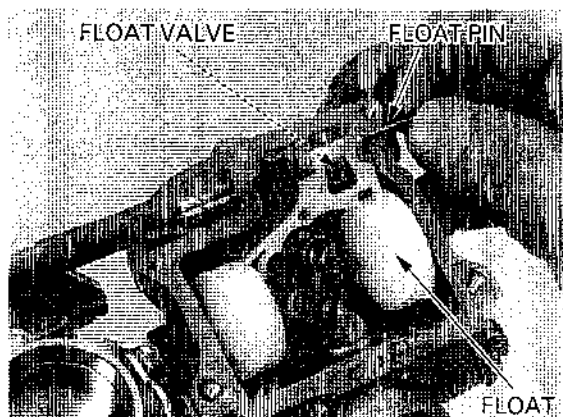

**CAUTION:**

*Handle all jets with care. They can easily be scored or scratched.*

Remove the main jet, needle jet holder, slow jet and valve seat/filter.

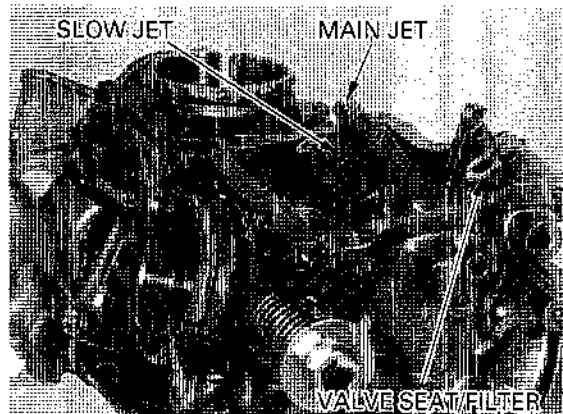

## FUEL SYSTEM

### NOTE:

- The pilot screws are factory pre-set and should not be removed unless the carburetors are overhauled.
- The pilot screw plugs are factory installed to prevent pilot screw misadjustment. Do not remove the plugs unless the pilot screws are being removed.
- Cover all openings with tape to keep metal particles out when the plugs are drilled.

Center punch the pilot screw plug. Center the drill point on the pilot screw plug. Drill through the plug with a 4 mm (5/32 in) drill bit. Attach a drill stop to the bit 3 mm (1/8 in) from the end to prevent drilling into the pilot screw.

### CAUTION:

- *Be careful not to drill into the pilot screw.*
- *Both pilot screws must be replaced even if only one requires it, for proper pilot screw adjustment (page 5-29).*

Force a self-tapping 4 mm screw, (P/N 93903-35410) into the drilled plug and continue turning the screw driver until the plug rotates with the screw.

Pull on the screw head with pliers to remove the plug.

Use compressed air to clean the pilot screw area and remove metal shavings.

Turn each pilot screw in and carefully count the number of turns until it seats lightly. Make a note of this to use as a reference when reinstalling the pilot screws.

### CAUTION:

*Damage to the pilot screw seat will occur if the pilot screw is tightened against the seat.*

Remove the pilot screw, spring, washer and O-ring.

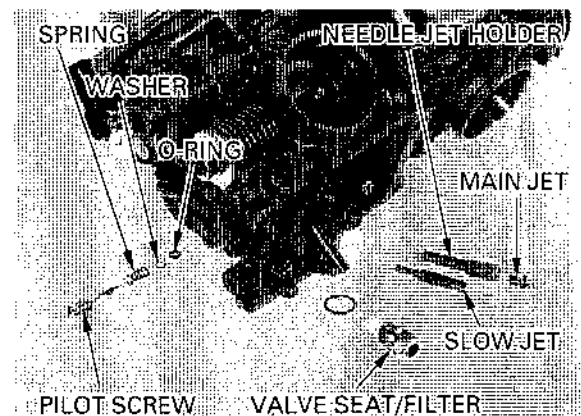
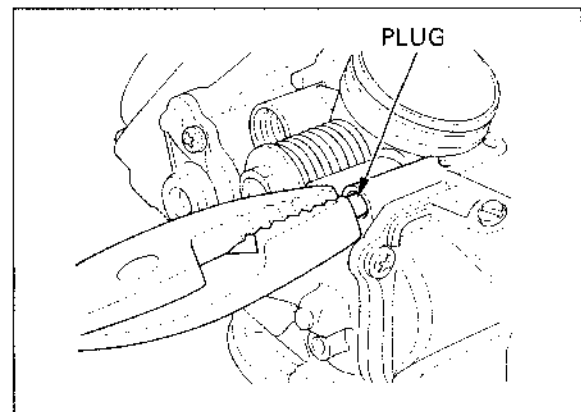
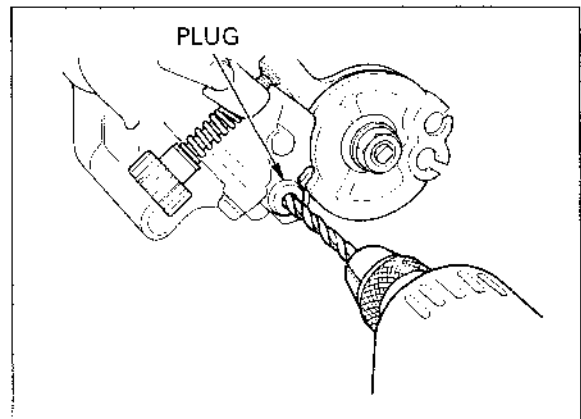

**DISASSEMBLY (After '98)**

Remove the bolt and disconnect the accelerator pump arm linkage.

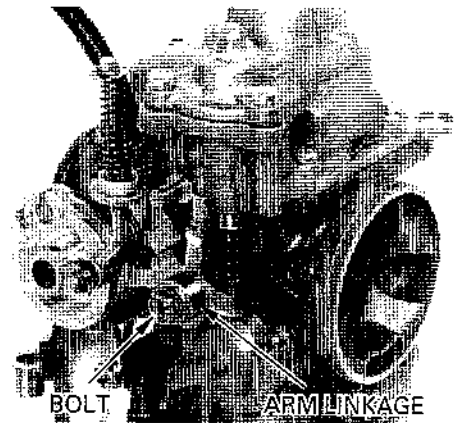

Remove the screws, float chamber and O-ring.

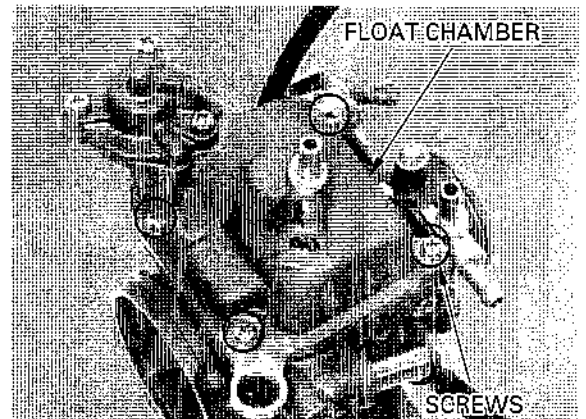

Remove the float pin, float and float valve.

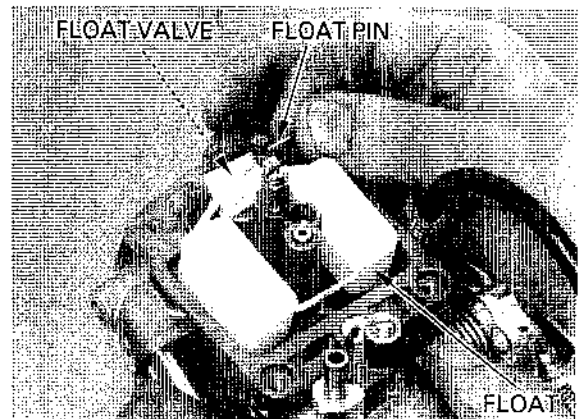

**CAUTION:**

*Handle all jets with care. They can easily be scored or scratched.*

Remove the main jet, needle jet holder, slow jet and pilot screw.

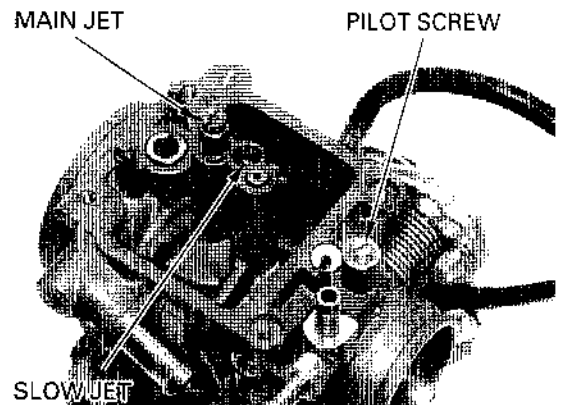

# FUEL SYSTEM

## INSPECTION

### FLOAT VALVE, VALVE SEAT

*A worn or contaminated valve does not seat properly and will eventually flood the carburetor.*

Check the float valve and valve seat for scoring, scratches, clogging or damage. Check the tip of the float valve where it contacts the valve seat, for stepped wear or contamination.

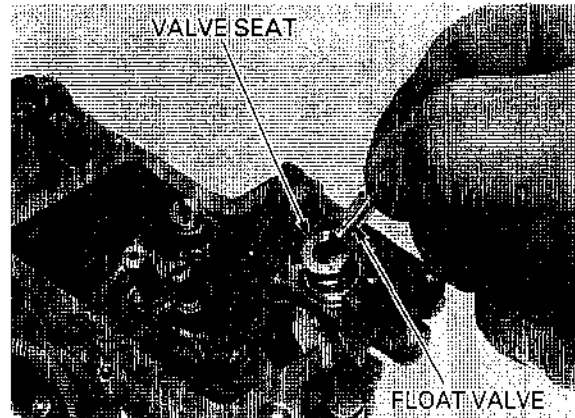

### JETS

Check the each jets for wear or damage. Clean the jets with non-flammable or high flash point solvent and blow open with compressed air.

### VALVE SEAT/FILTER

Check the float valve seat and filter for grooves, nicks or deposits.

### PILOT SCREW

Check the pilot screw for stepped wear or damage.

Replace these parts if necessary.

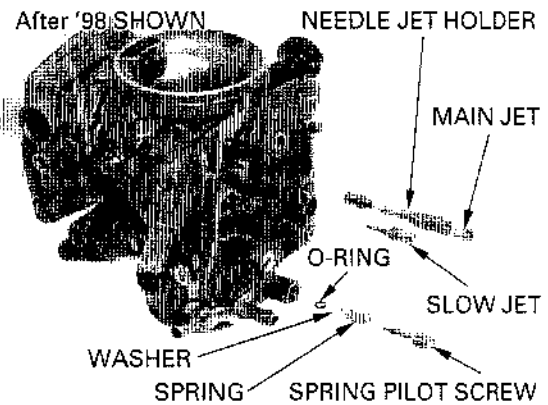
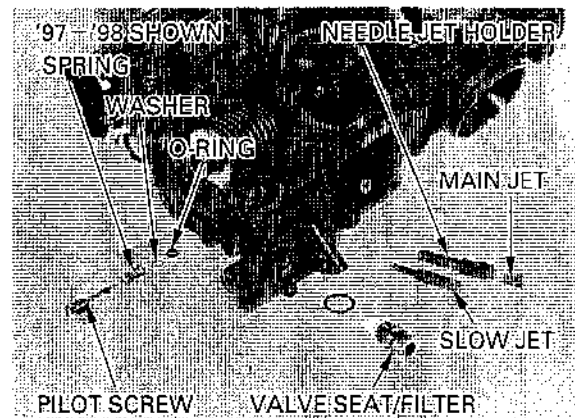

## ASSEMBLY

Install the main jet, needle jet holder, slow jet and valve seat/filter.

Install the O-ring, washer, spring, pilot screw and new pilot screw plug ('97-'98 models only).

### NOTE:

- Install the pilot screw and return it to its original position as noted during removal.
- Perform pilot screw adjustment if new pilot screw is installed (page 5-29).





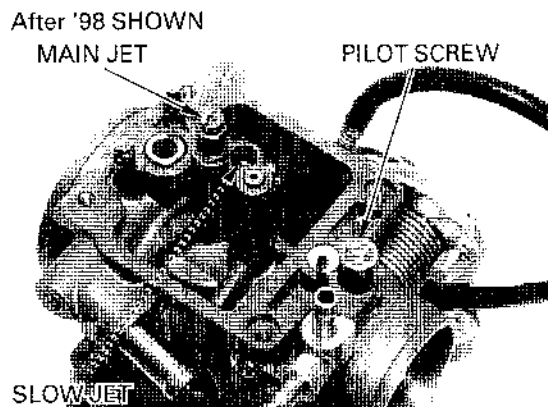

Hang the float valve onto the float arm lip.  
Install the float valve with the float in the carburetor body, then install the float pin through the body and float.

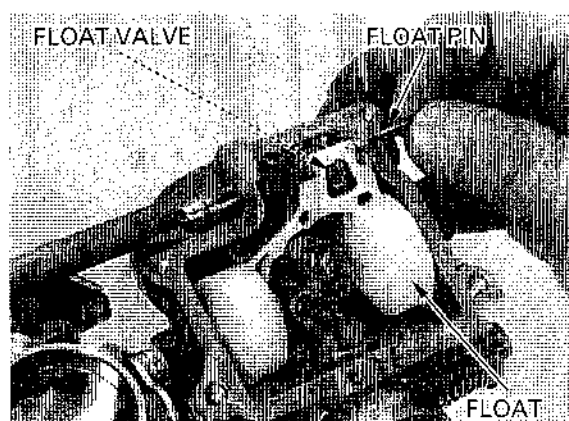

**FLOAT LEVEL**

**NOTE:**

- Check the float level after checking the float valve and float.
- Set the float level gauge so that it is perpendicular to the float chamber face and in line with the main jet.

Set the carburetor so that the float valve just contacts the float arm lip. Be sure that the float valve tip is securely in contact with the valve seat. Check the float level with the float level gauge.

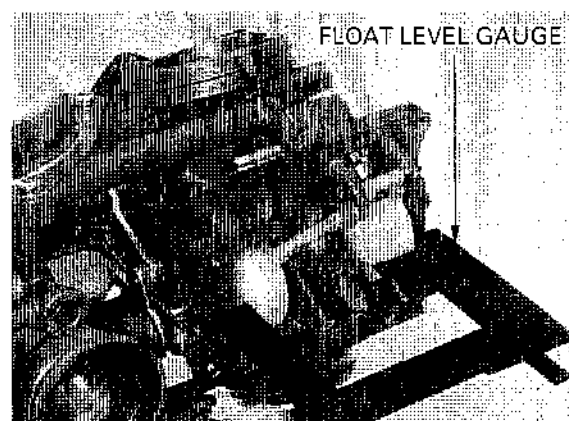

**TOOLS:**

Carburetor float level gauge: 07401-0010000

**FLOAT LEVEL**

- '97 - '98: 7.0 mm (0.28 in)
- After '98: 18.5 mm (0.73 in)

If the level is out of specification, replace the float.

## FUEL SYSTEM

Install the new O-ring into the float chamber groove.

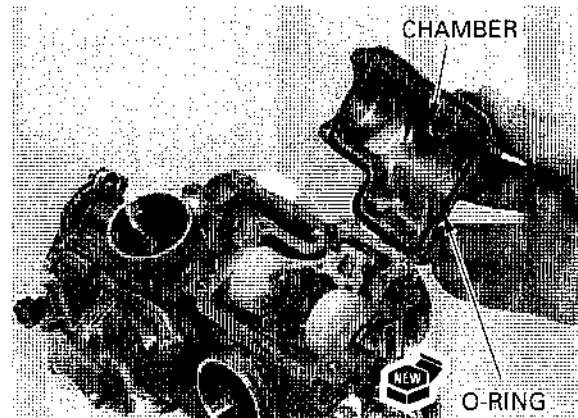

Install the float chamber.  
Install and tighten the screw securely.

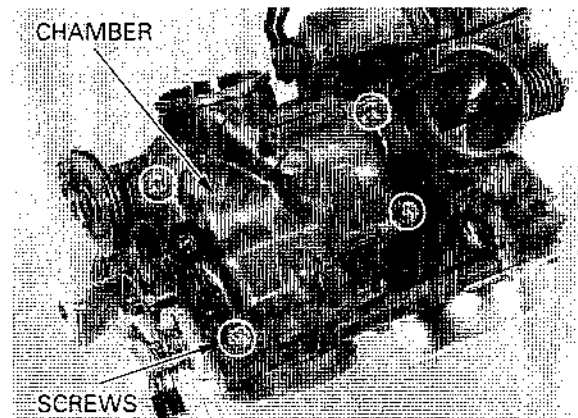

Install the accelerator pump arm linkage and tighten the bolt securely (After '98).

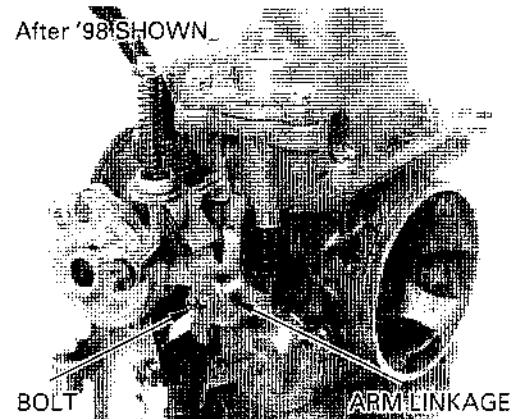

## AIR CUT-OFF VALVE

### DISASSEMBLY

Remove the two screws, the set plate and the air cut-off valve cover.

#### NOTE:

The air cut-off valve cover is under spring pressure.  
Do not lose the spring and screws.

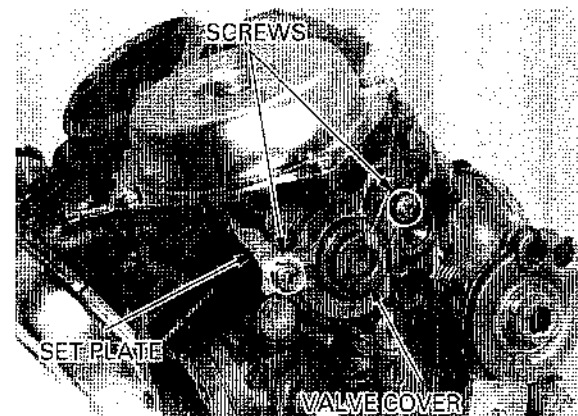

### INSPECTION

- Check the diaphragm for deterioration, pin hole or other damage.
- Check the spring for deterioration or other damage.
- Check the diaphragm needle for excessive wear at the tip or other damage.
- Check the air vent orifice for clogging.
- Check the U-ring for damage ('97 - '98).

Replace the air cut off valve as an assembly, if necessary.

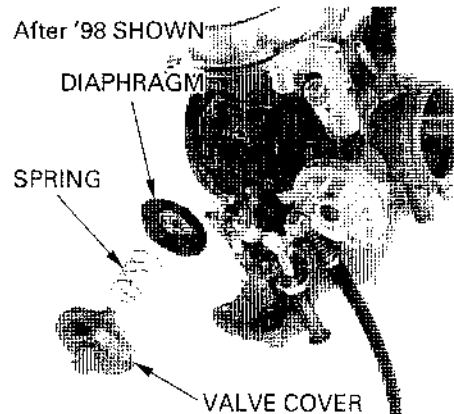
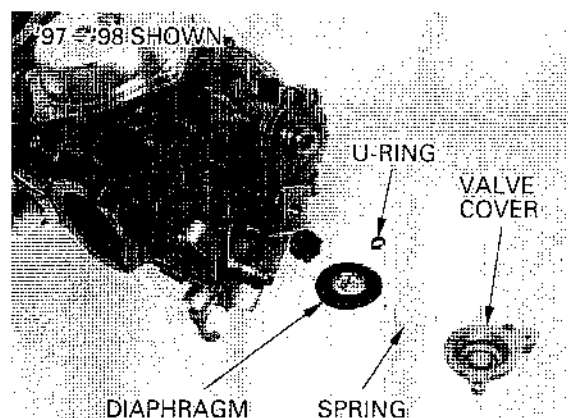

### ASSEMBLY

Assembly is in the reverse order of disassembly.

**NOTE:**

- Install the U-ring with its flat side toward the carburetor body as shown ('97 - '98).
- Be careful not pinch the diaphragm.

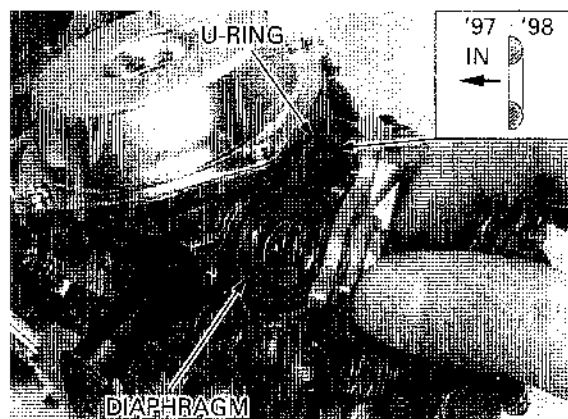

## CARBURETOR BODY CLEANING

**CAUTION:**

- *Cleaning the air and fuel passages with a piece of wire will damage the carburetor body.*
- *Remove the diaphragms to prevent damage to them before using air to blow open passage.*

Disassembled the carburetor (page 5-14).

Blow open all air and fuel passages in the carburetor body with compressed air.  
Clean the fuel strainer in the float valve using compressed air from the float valve seat side.

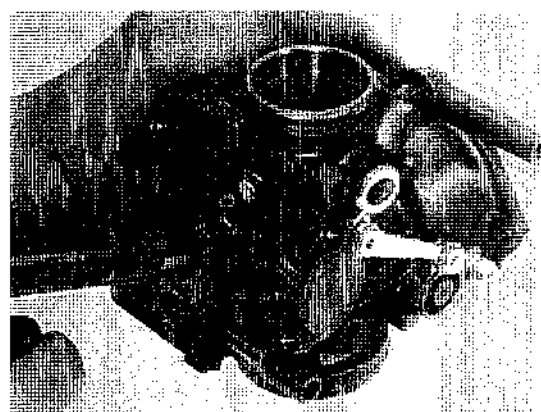

**CARBURETOR REASSEMBLY ('97 - '98)**

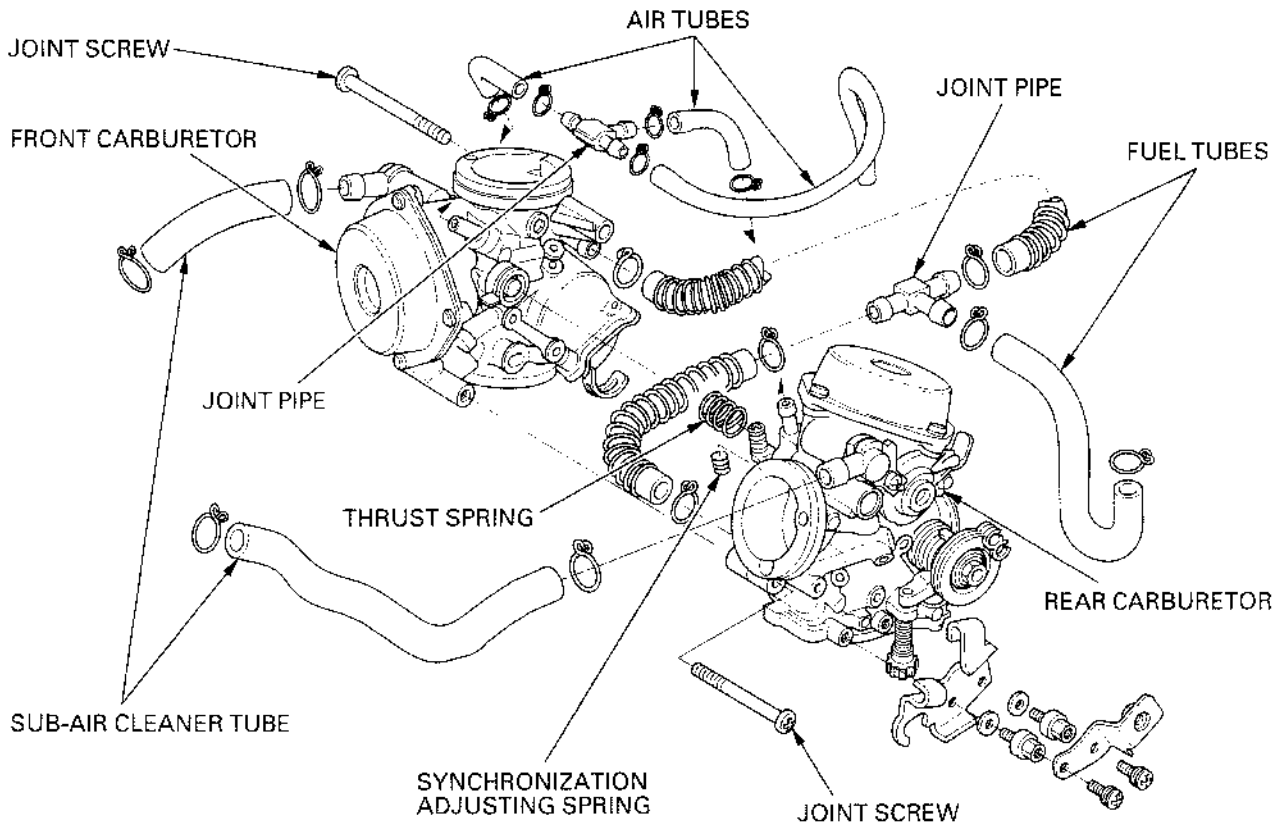

Loosen the synchronization adjusting screw until there is no spring tension.

Install the thrust spring between the throttle links.

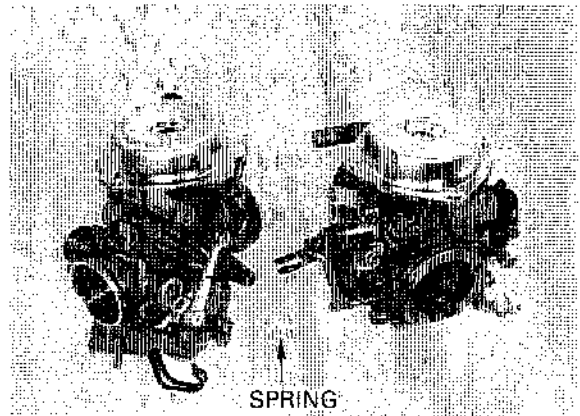

Secure the carburetors together with the two screws.

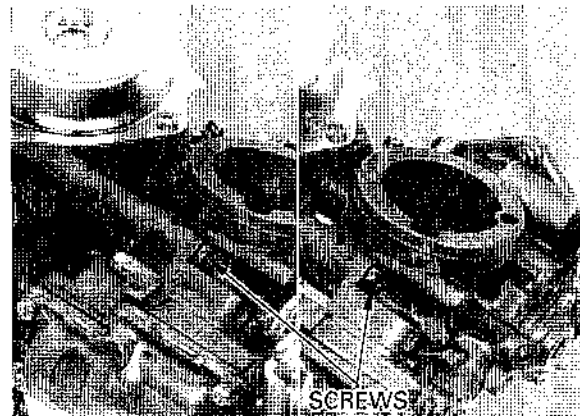

Install the synchronization spring and synchronization adjusting screw.

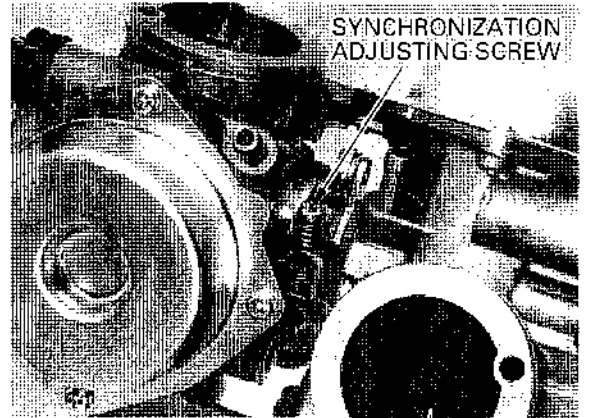

**INSPECT THROTTLE OPERATION AS DESCRIBED BELOW:**

Open the throttle slightly by rotating the throttle valve, then release the throttle. Make sure that there is no drag when opening and closing the throttle.

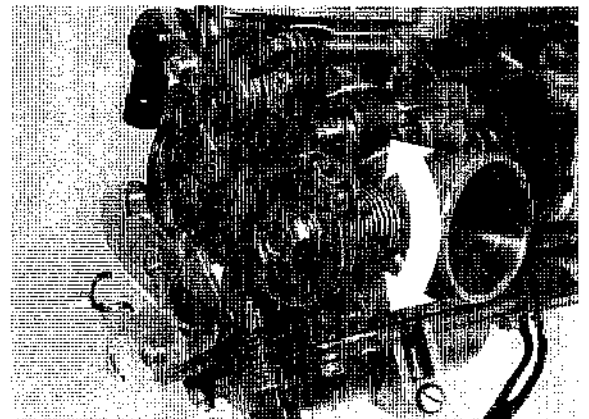

Turn the throttle stop control knob to align the rear cylinder carburetor throttle valve with the edge of the by-pass hole.

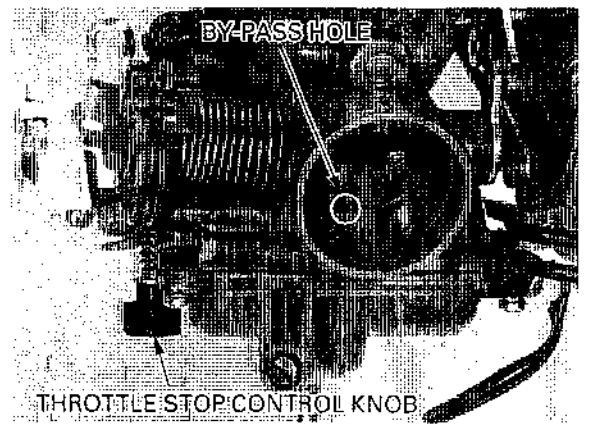

Align the front cylinder carburetor throttle valve with the by-pass hole edge by turning the synchronization adjusting screw.

Make sure the throttle returns smoothly.

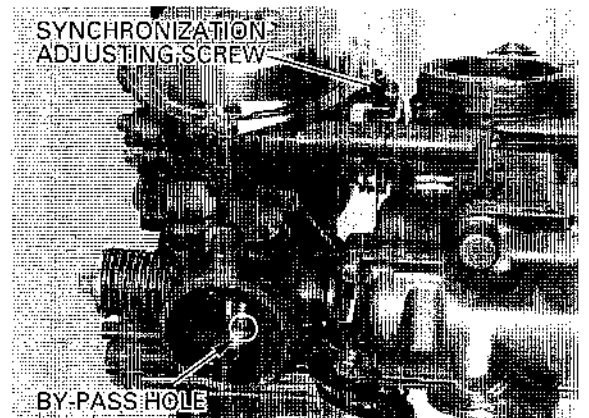

## FUEL SYSTEM

### CARBURETOR REASSEMBLY (After '98)

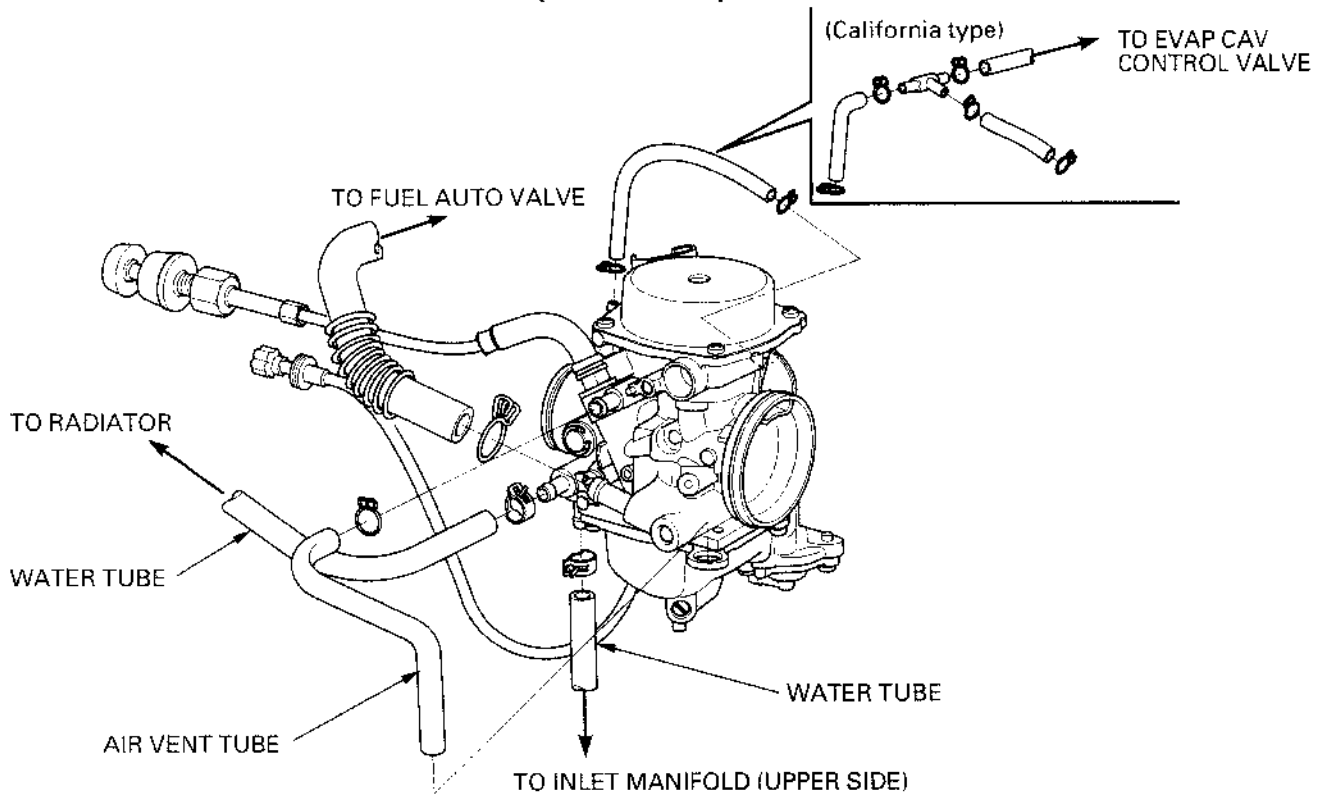

### CARBURETOR INSTALLATION ('97 - '98)

*Route the wires and tubes properly (page 1-22).* Install the starting enrichment (SE) valve and cable. Install the fuel and air tubes as shown.

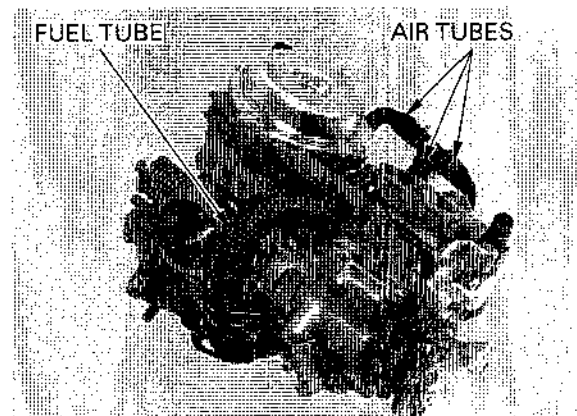
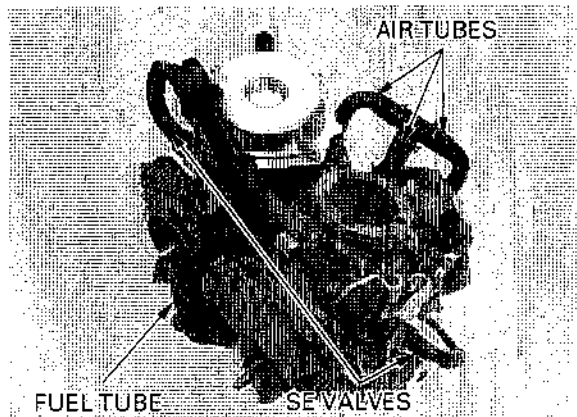

Install the carburetor to the insulator.  
Tighten the insulator band screws securely.

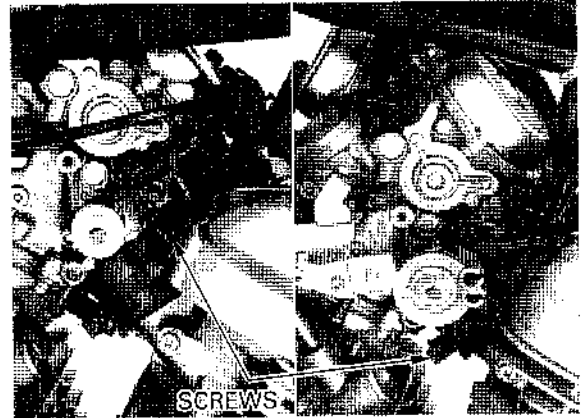

Connect the throttle cables to the throttle drum.  
Install the throttle link cover and screw.

**TORQUE:** 2 N·m (0.21 kgf·m , 1.5 lbf·ft)

- Install the following parts:
- Air cleaner chamber (page 5-16)
  - Air cleaner housing (page 5-5)
  - Fuel tank (page 2-7)

- Perform the following inspections and adjustment.
- Pilot screw (page 5-29)
  - Carburetor synchronization (page 3-17)
  - Throttle grip free play (page 3-4)
  - Engine idle speed (page 3-18)
  - Carburetor choke (page 3-6)

After installation, turn the ignition switch ON and check the fuel line for leakage.

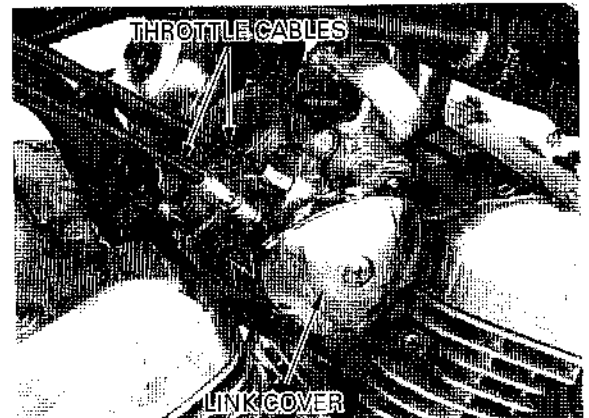

## CARBURETOR INSTALLATION (After '98)

**NOTE:**

*Route the wires and tubes properly (page 1-24).*

At the carburetor insulator installation, install the insulator with the "CARB" mark facing the carburetor.

Install the carburetor insulator onto the carburetor by aligning its groove with the lug of the carburetor.

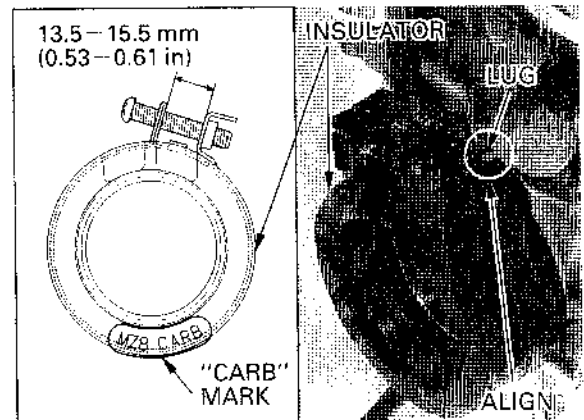

Install the throttle cables to the throttle drum.  
Install the adjusters to the stay.



## FUEL SYSTEM

Connect the water tubes.  
Connect the No. 11 tube (California type only/  
After '98: page 1-37).

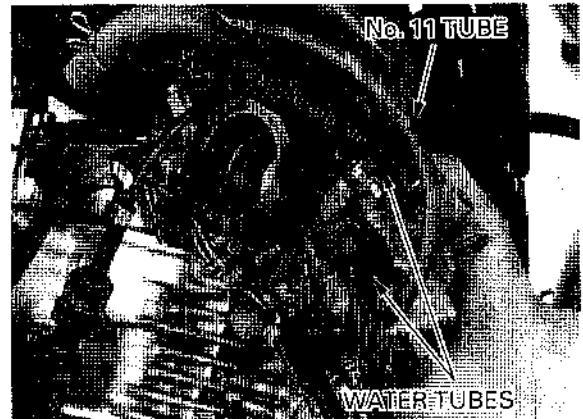

Install the carburetor on to the inlet manifold by  
aligning the insulator groove with the lug of the  
inlet manifold.  
Tighten the insulator band screws.

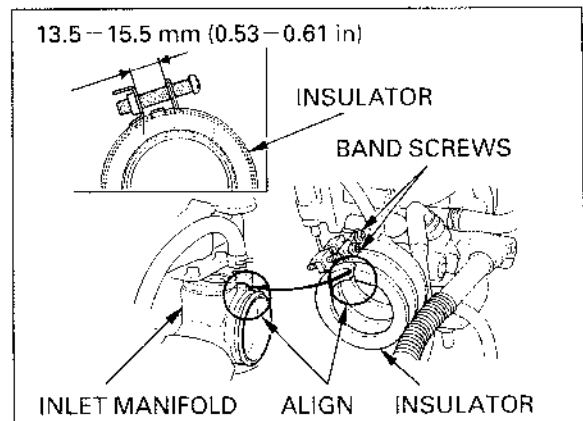

Adjust the throttle grip free play by tightening the  
adjusters (page 3-6).

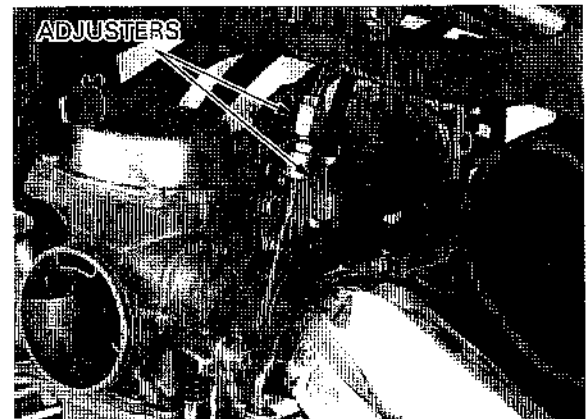

Connect the water tube to the inlet manifold.  
Connect the No. 5 tube (California type only/  
After '98: page 1-37).

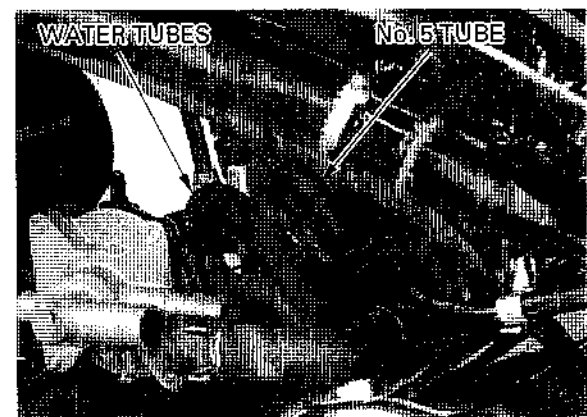



Connect the fuel tube.  
 Connect the following tubes to the EVAP CAV CONTROL VALVE (California type only).  
 - No. 6 tube — See page 1-37  
 - No. 10 tube — Vacuum hose routing diagram/After '98

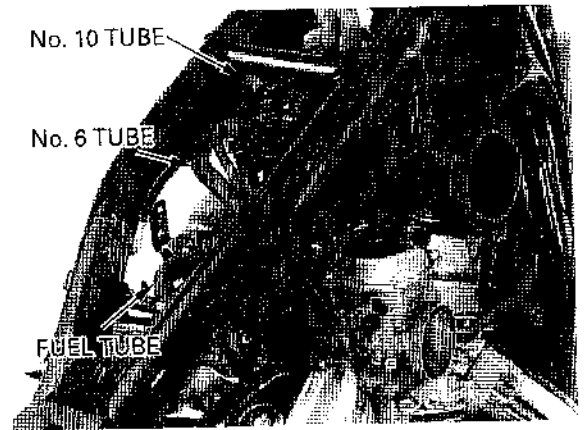

Install the choke knob and tighten the nut.  
 Install the throttle stop control knob.  
 Install the fuel tank (page 2-7).  
 Install the link cover (page 5-35).

Perform the following inspections and adjustments.  
 - Pilot screw (page 5-29)  
 - Engine idle speed (page 3-18)  
 - Carburetor choke (page 3-6)

After installation, check the fuel and water lines for leakage.

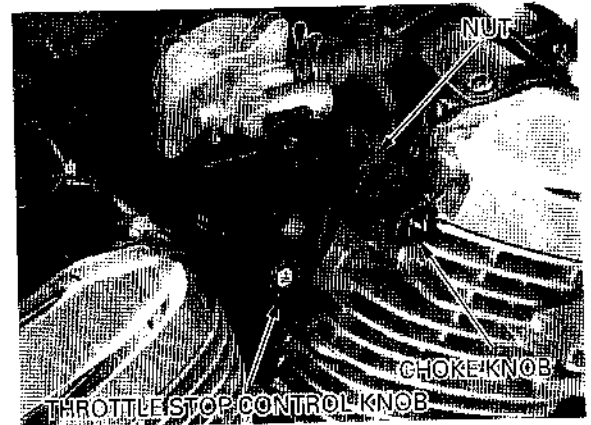

## PILOT SCREW ADJUSTMENT ('97 - '98)

### IDLE DROP PROCEDURE

#### ▲WARNING

- If the engine must be running to do some work, make sure the area is well-ventilated. Never run the engine in an enclosed area.
- The exhaust contains poisonous carbon monoxide gas that may cause loss of consciousness and may lead to death.

#### NOTE:

- Make sure the carburetor synchronization is within specification before pilot screw adjustment ('97 - '98 only; page 3-17).
- The pilot screw factory pre-set and no adjustment can be done unless it is replaced.
- Use a tachometer with graduations of 50 rpm or smaller that will accurately indicate a 50 rpm change.

1. Remove the pilot screw plugs (page 5-13).
2. Turn each pilot screw clockwise until it seats lightly, then back it out to specification given.

INITIAL OPENING: 1 1/4 turns out

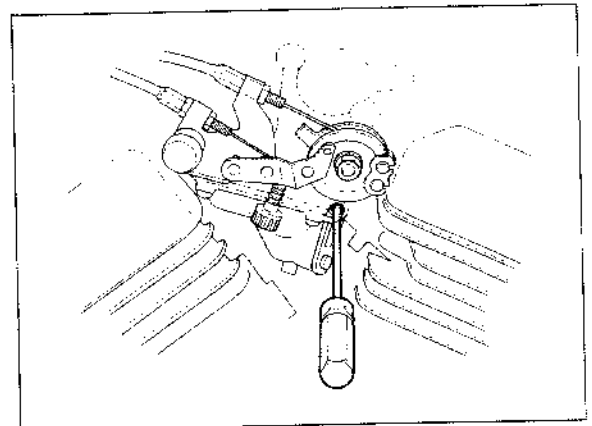

### CAUTION:

*Damage to the pilot screw seat will occur if the pilot screw is tightened against the seat.*

3. Warm up the engine to operating temperature. Stop and go riding for 10 minutes is sufficient.
4. Attach a tachometer according to its manufacturer's instructions.
5. Start the engine and adjust the engine idle speed to the specified rpm with the throttle stop control knob.

**IDLE SPEED:** 1,200 ± 100 rpm

6. Turn each pilot screw 1/2 turn out from the initial setting.
7. If the engine speed increase by 50 rpm or more, turn each pilot screw out by successive 1/2 turn increments until engine speed does not increase.
8. Adjust the idle speed with the throttle stop screw.
9. Turn the rear cylinder carburetor pilot screw in until the engine speed drops 50 rpm.
10. Turn the rear cylinder carburetor pilot screw counterclockwise to the final opening from the position in step 9.

**FINAL OPENING:** 1 turn out

11. Adjust the idle speed with the throttle stop screw.
12. Perform steps 9, 10 and 11 for the front cylinder carburetor pilot screw.
13. Drive new pilot screw plugs into the pilot screw bores with a 7 mm valve guide driver (P/N 07942-8230000). When fully seated, the plug surfaces will be recessed 1 mm.

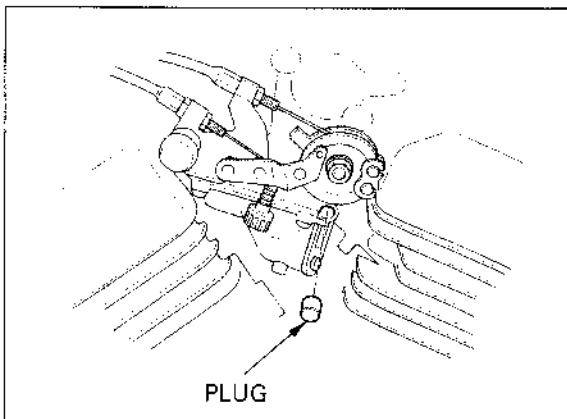
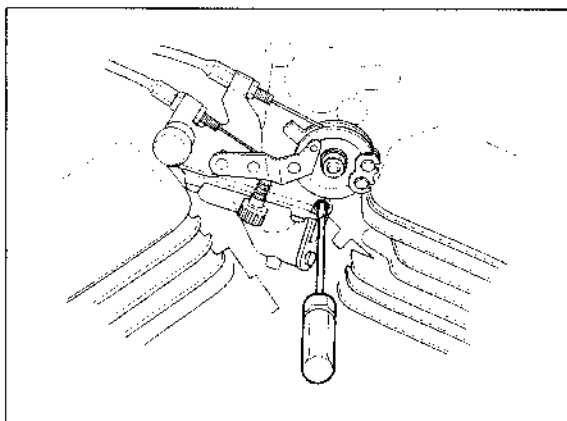
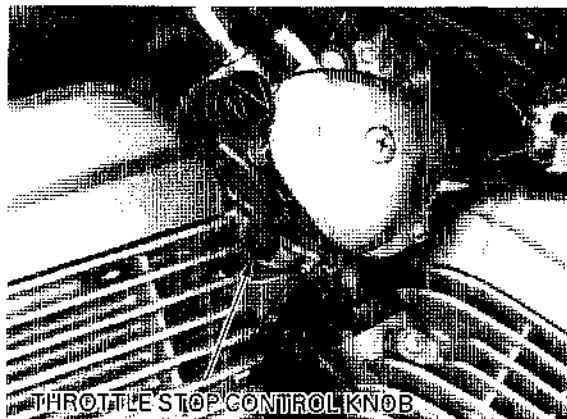

## PILOT SCREW ADJUSTMENT (After '98)

### IDLE DROP PROCEDURE

#### ▲WARNING

- If the engine must be running some work, make sure the area is well-ventilated. Never run the engine in an enclosed area.
- The exhaust contains poisonous carbon monoxide gas that may cause loss of consciousness and may lead to death.

### NOTE:

- The pilot screw is factory pre-set. Adjustment is not necessary unless the carburetor is overhauled or a new pilot screw is installed.
- Use a tachometer with graduations of 50 rpm or smaller that will accurately indicate a 50 rpm change.

1. Turn the pilot screw with the pilot screw wrench clockwise until it seats lightly, and then back it out to the specification given. This is an initial setting prior to the final pilot screw adjustment.

**TOOL:**

**Pilot screw wrench**             07LMA-MT8010A  
  with  
  07PMA-MZ2011A

**CAUTION:**

*Damage to the pilot screw seat will occur if the pilot screw is tightened against the seat.*

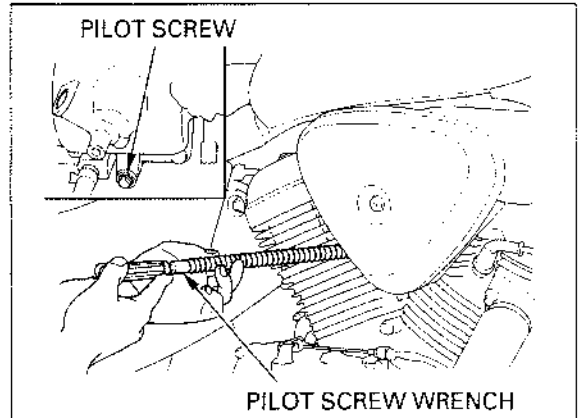

**INITIAL OPENING:**

**49 state/Canada type:** 3 turns out  
**California type:**         2 3/4 turns out

2. Warm the engine up to operating temperature. Stop and go riding for 10 minutes is sufficient.
3. Stop the engine and connect a tachometer according to the tachometer manufacturer's instructions.
4. Start the engine and adjust the idle speed with the throttle stop control knob.

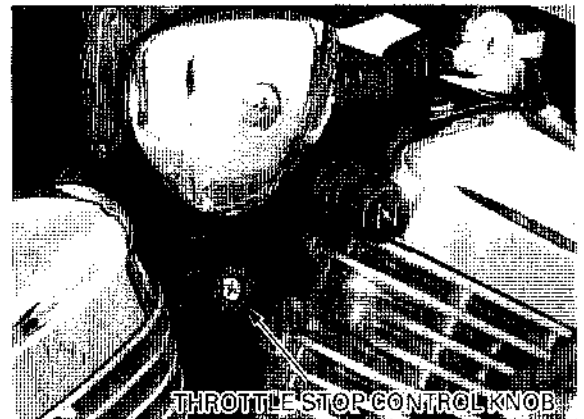

**IDLE SPEED:** 1,200 ± 100 rpm

5. Turn the pilot screw in or out slowly to obtain the highest engine speed.
6. Readjust the idle speed with the throttle stop control knob.
7. Turn the pilot screw in until the engine speed drops 50 rpm.
8. Turn the pilot screw counterclockwise to the final opening from the position in step 7.

**FINAL OPENING:** 3/4 turns out

9. Readjust the idle speed with the throttle stop screw.

## FUEL SYSTEM

### FUEL PUMP ('97 – '98)

#### **▲WARNING**

*Gasoline is extremely flammable and is explosive under certain conditions. KEEP OUT OF REACH OF CHILDREN.*

#### **SYSTEM INSPECTION**

Remove the seat (page 2-2).

Turn the ignition switch OFF.  
Disconnect the fuel cut relay 3P connector and connect the voltmeter at the 3P connector wire harness side.

**CONNECTION:** Black (+) - body ground (-)

Turn the ignition switch ON.  
There should be battery voltage.  
If there is no voltage, check for an open circuit or loose connection in Black wire.  
If there is battery voltage, check for continuity in the Black/Blue wire.

Check for continuity between the Black/Blue wire and ground at the 3P connector wire harness side.

**CONNECTION:** Black/Blue - body ground  
**STANDARD:** No continuity

If there is continuity, replace the fuel cut relay.

If there is no continuity, short the terminals of the 3P connector wire harness side with the suitable jumper wire.

**SHORT TERMINALS:** Black/Blue - Black

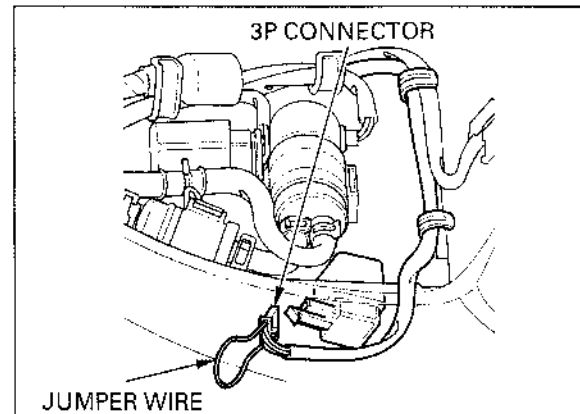
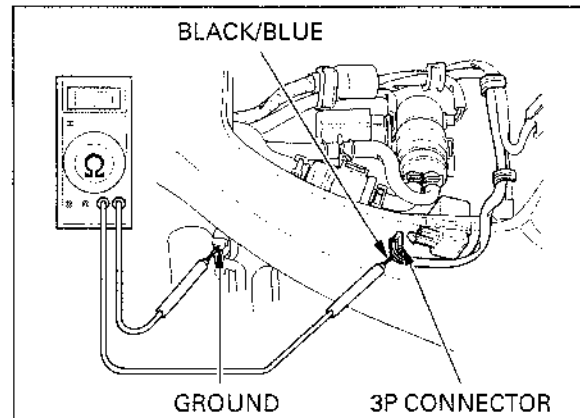
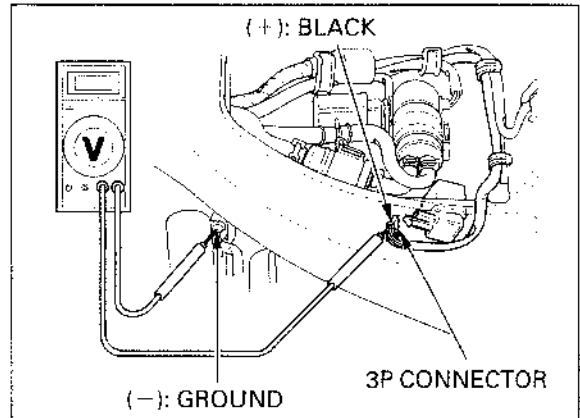

Disconnect the fuel pump 2P (White) connector and connect the voltmeter at the 2P (White) connector wire harness side.

**CONNECTION:** Black/Blue (+) - Green (-)

Turn the ignition switch ON and measure the voltage at the 2P (White) connector.

**STANDARD:** Battery voltage

If there is no voltage, check for an open circuit or loose connection in Black/Blue and Green wires. If there is battery voltage, replace the fuel pump.

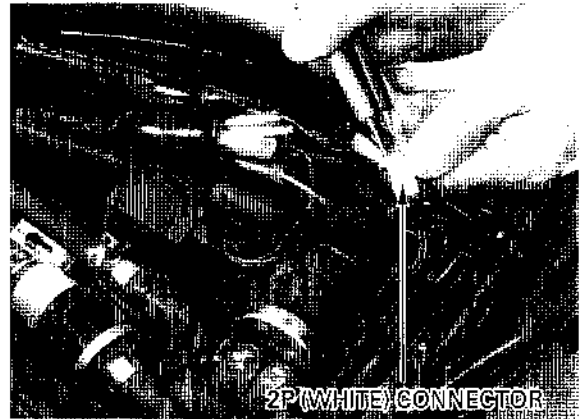

### DISCHARGE VOLUME INSPECTION

Remove the seat (page 2-2).

Disconnect the fuel cut relay 3P connector. Short the Black and Black/Blue terminals with a suitable jumper wire. Disconnect the fuel pump outlet tube from the tube joint. Hold a graduated beaker under the fuel pump outlet tube.

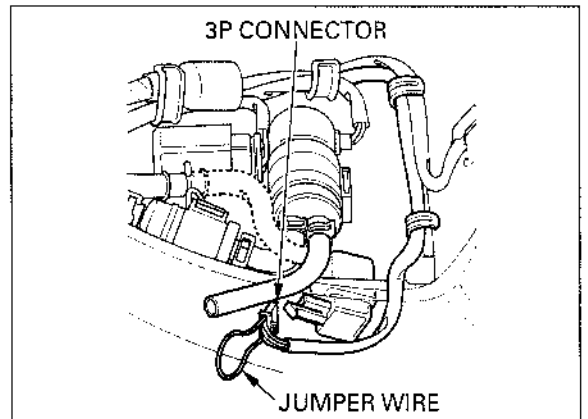

Turn the ignition switch ON and let the fuel flow into the beaker for 5 seconds, then turn the ignition switch OFF. Multiply the amount in the beaker by 12 to determine the fuel pump flow capacity per minute.

**FUEL PUMP FLOW CAPACITY:**  
800 cm<sup>3</sup> (27.1 US oz, 28.2 Imp oz) min./minute

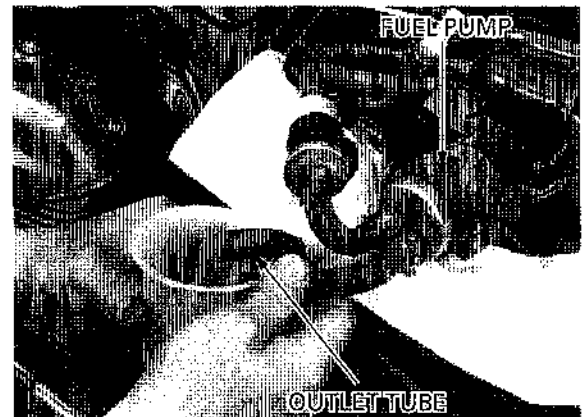

### REMOVAL

Remove the fuel tank (page 2-4).

Disconnect the fuel pump 2P (white) connector and remove the fuel pump wire from the clamps.

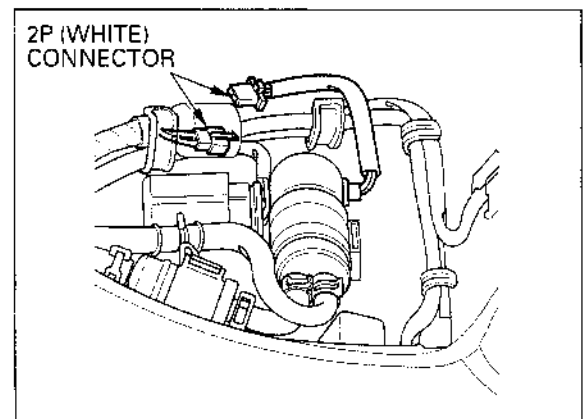

## FUEL SYSTEM

Disconnect the fuel tubes (pump-to-filter, pump-to-carburetor).

Disconnect the fuel pump tube.  
Remove the fuel pump from the pump bracket.

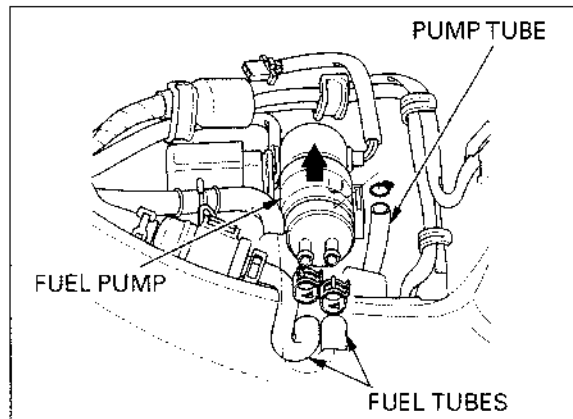

## INSTALLATION

### NOTE:

Route the wire harness and tubes properly (page 1-25).

Connect the fuel pump tube to the fuel pump.  
Install the fuel pump to the pump bracket.  
Connect the fuel tubes (pump-to-filter, pump-to-carburetor).

### NOTE:

Connect the fuel tubes (pump-to-filter) to fuel pump "IN" mark side.

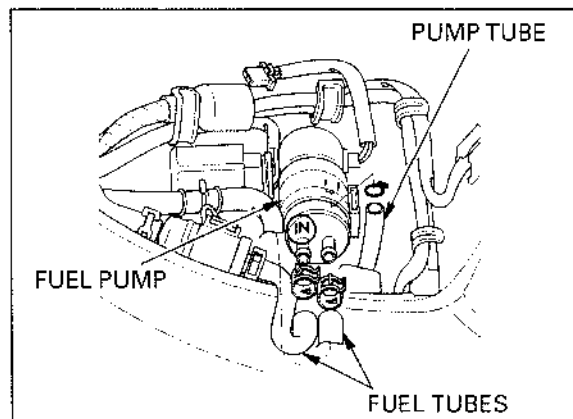

Connect the fuel pump 2P (white) connector and install the fuel pump wire to the clamps.

Install the seat (page 2-2).

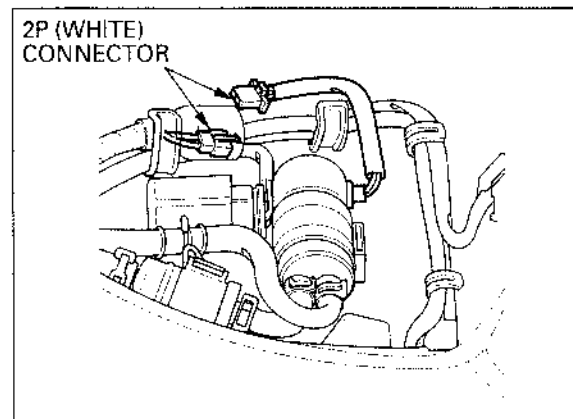

## FUEL FILTER ('97 — '98)

### REMOVAL

Remove the seat (page 2-2).

Disconnect the fuel tube (pump-to-filter).  
Remove the fuel filter and rubber cushion from the filter bracket.

Disconnect the fuel tubes from the fuel filter.  
Remove the rubber cushion from the fuel filter.

Check the fuel filter for damage or contamination.  
Replace the fuel filter if necessary.



## INSTALLATION

Installation is in the reverse order of removal.

### NOTE:

At fuel filter and rubber cushion installation, install the filter with the "⇒" mark facing the fuel pump.

Install the seat (page 2-2).

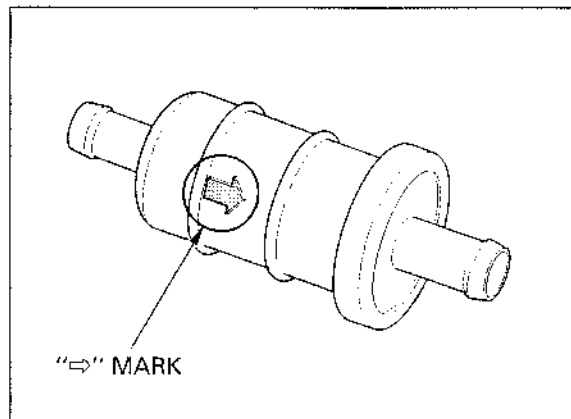

## FUEL AUTO VALVE (After '98)

### INSPECTION

#### ▲WARNING

*Gasoline is extremely flammable and is explosive under certain conditions. KEEP OUT OF REACH OF CHILDREN.*

Remove the fuel tank mount bolt (page 2-4).  
 Disconnect the air tube and fuel (fuel auto valve-to-carburetor) tube.  
 Connect the vacuum pump to the air tube joint.  
 Apply the vacuum pump and inspect the fuel flow from the fuel tube.

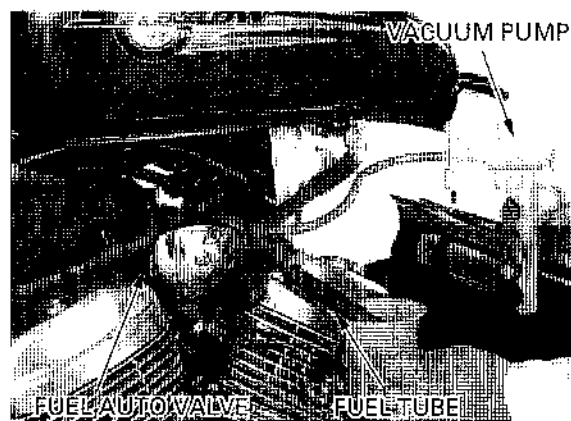

### REMOVAL

Remove the fuel tank (page 2-3).  
 Remove the screw and the cover.  
 Remove the choke knob and throttle stop control knob (page 5-11).

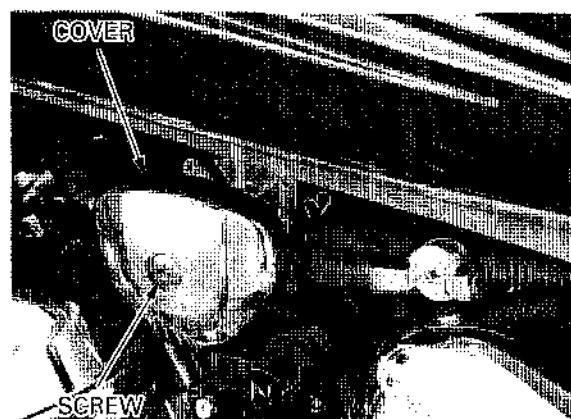

Disconnect the fuel tube and air tube.  
 Remove the two bolts and washer.  
 Remove the fuel auto valve.

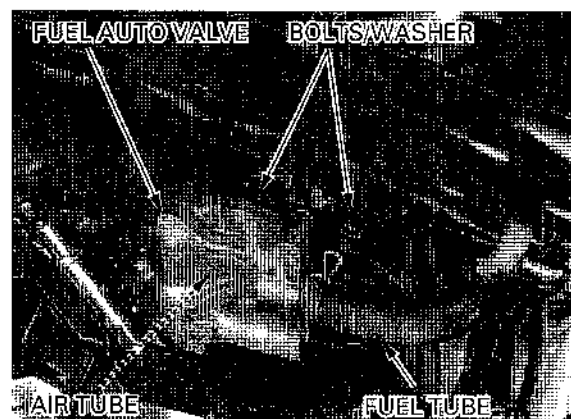

## FUEL SYSTEM

### DISASSEMBLY

Remove the screws, clamp and the diaphragm cover.

#### NOTE:

The diaphragm cover is under spring pressure.  
Do not lose the spring and screws.

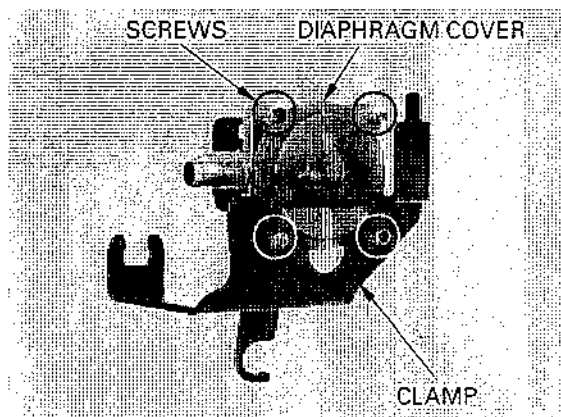

Remove the diaphragms and spring.  
Check the diaphragms for damage or pin holes.

#### NOTE:

Be careful not to damage the diaphragms.

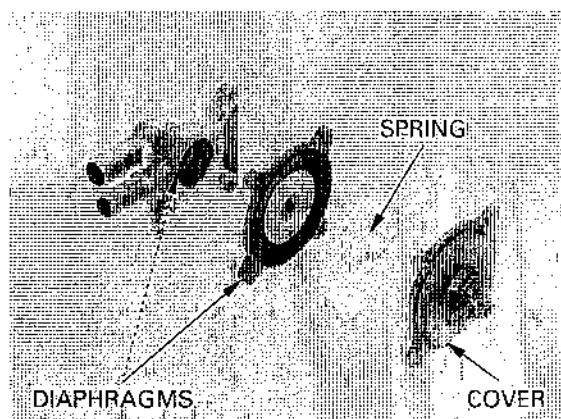

### ASSEMBLY

Install the diaphragms and spring.

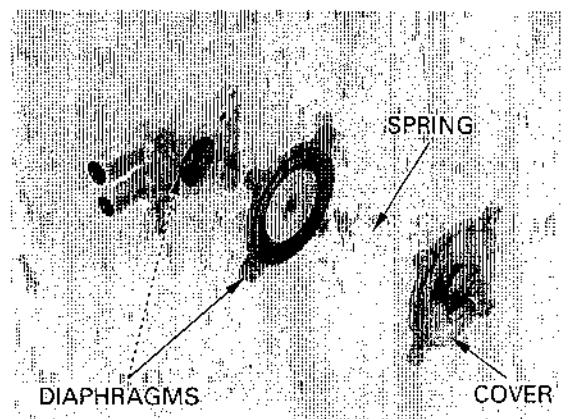

Install the diaphragm cover and clamp.  
Tighten the screws.

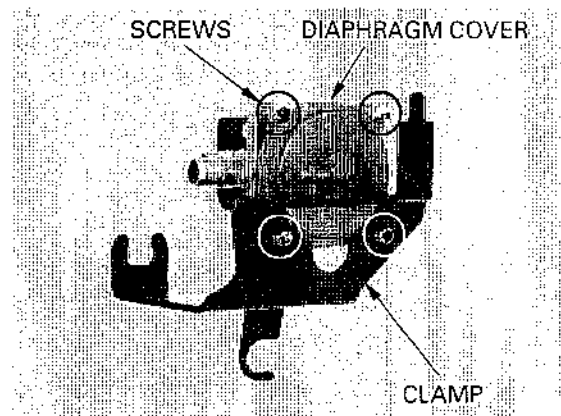



## INSTALLATION

Install the fuel auto valve to the inlet manifold.  
Install the washer and tighten the two bolts.  
Connect the air tube and fuel tube.

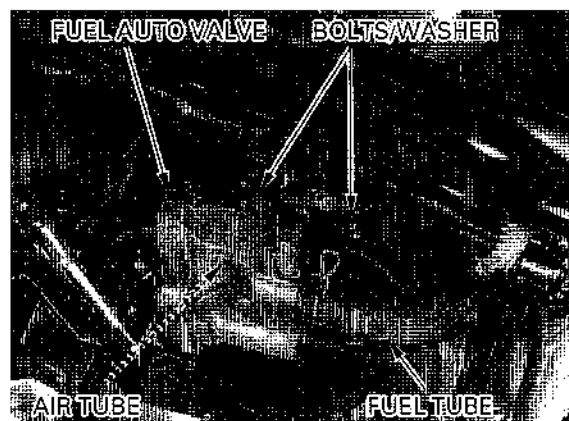

Install the choke knob and throttle stop control knob (page 5-29).  
Install the cover and tighten the screw to the specified torque.

**TORQUE:** 2 N·m (0.21 kgf·m , 1.5 lbf·ft)

Install the fuel tank (page 2-7).

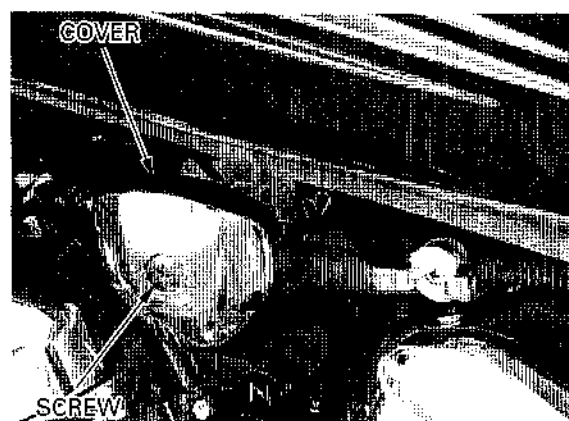

## HIGH ALTITUDE ADJUSTMENT (U.S.A. ONLY/'97 - '98)

### NOTE:

When the vehicle is to be operated continuously above 2,000 m (6,500 feet) the carburetors must be readjusted as follows to improve driveability and decrease exhaust emissions.

Remove each pilot screw plug (page 5-13).  
Warm up the engine to operating temperature.  
Stop and go driving for 10 minutes is sufficient.  
Turn each pilot screw to the specification shown below.

**HIGH ALTITUDE SETTING:** 1/2 turn in  
from low altitude  
setting

Adjust the idle speed to 1,200 ± 100 rpm, with the throttle stop control knob.  
Drive new pilot screw plugs into the pilot screw bores (page 5-21).

### NOTE:

This adjustment must be made at high altitude to ensure proper high altitude operation.

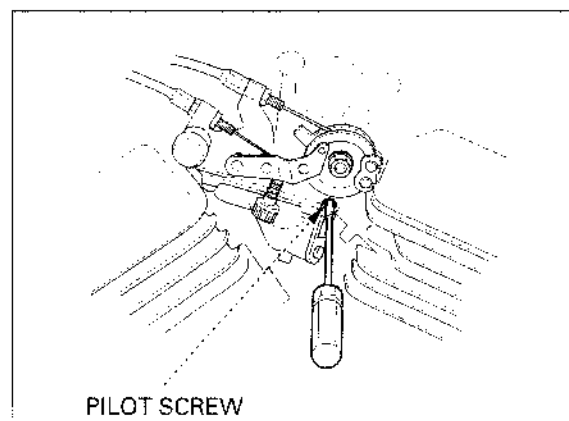

## FUEL SYSTEM

Do not attach the label to any part that can be easily removed from the vehicle.

Attach a vehicle Emission Control Information update Label onto the inside of the left side cover as shown. See SL # 132 for information on obtaining the label.

### ▲WARNING

**Sustained operation at an altitude lower than 1,500 m (5,000 feet) with the carburetors adjusted for high altitude may cause the engine to idle roughly and engine may stall in traffic and may cause engine damage due to overheating.**

When the vehicle is to be operated continuously below 1,500 m (5,000 feet), turn each pilot screw to the specification below, its original, low altitude, position.

**LOW ALTITUDE SETTING:** 1/2 turn out from high altitude setting.

Adjust the idle speed to 1,200  $\pm$  100 rpm with the throttle stop control knob.

Drive new pilot screw plugs into the pilot screw bores (page 5-21).

Be sure to make these adjustments at low altitude. Remove the Vehicle Emission Control Update Label that attached to the inside of the left side cover after adjusting for the low altitude.

'97-'98 SHOWN: **NEW**

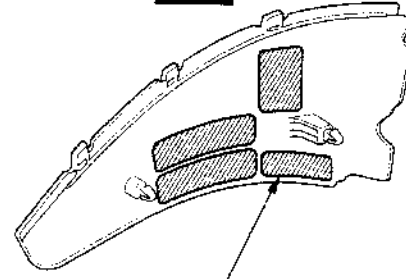

VEHICLE EMISSION CONTROL INFORMATION UPDATE LABEL

VEHICLE EMISSION CONTROL INFORMATION UPDATE  
HONDA MOTOR CO., LTD

THIS VEHICLE HAS BEEN ADJUSTED TO  
IMPROVE EMISSION CONTROL PERFORMANCE  
WHEN OPERATED AT HIGH ALTITUDE.



ALTITUDE PERFORMANCE ADJUSTMENT INSTRUCTIONS  
ARE AVAILABLE AT YOUR AUTHORIZED HONDA DEALER.

## HIGH ALTITUDE ADJUSTMENT (U.S.A. ONLY/After '98)

### NOTE:

When the vehicle is to be operated continuously above 2,000 m (6,500 feet) the carburetor must be readjusted as follows to improve driveability and decrease exhaust emissions.

Warm up the engine to operating temperature. Stop and go driving for 10 minutes is sufficient. Turn the pilot screw to the specification shown below.

### TOOLS:

**Pilot screw wrench** 07LMA-MT8010A  
with  
PMA-MZ2011A

**HIGH ALTITUDE SETTING:** 1/2 turn in from low altitude setting

Adjust the idle speed to 1,200  $\pm$  100 rpm, with the throttle stop control knob.

PILOT SCREW

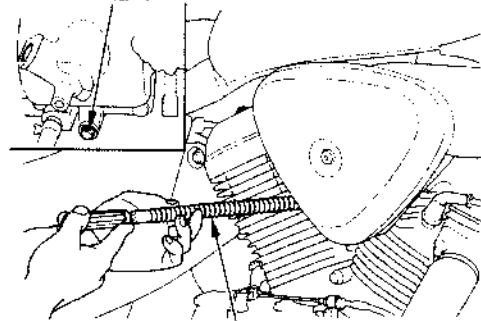

PILOT SCREW WRENCH

'99 SHOWN:

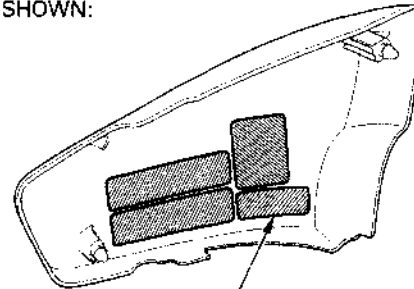

VEHICLE EMISSION CONTROL INFORMATION UPDATE LABEL

**NOTE:**

This adjustment must be made at high altitude to ensure proper high altitude operation.

*Do not attach the label to any part that can be easily removed from the vehicle.*

Attach a Vehicle Emission Control Information update Label as shown. See SL # 132 for information on obtaining the label.

**▲WARNING**

**Sustained operation at an altitude lower than 1,500 m (5,000 feet) with the carburetor adjusted for high altitude may cause the engine to idle roughly and engine may stall in traffic and may cause engine damage due to overheating.**

When the vehicle is to be operated continuously below 1,500 m (5,000 feet), turn the pilot screw to the specification below, its original, low altitude, position.

**LOW ALTITUDE SETTING:**

- 49 state/Canada type:** 2 1/2 turns out
- California type:** 2 1/4 turns out from high altitude setting.

Adjust the idle speed to 1,200 ± 100 rpm with the throttle stop control knob.

Be sure to make these adjustments at low altitude. Remove the Vehicle Emission Control Update Label that attached to the inside of the left side cover after adjusting for the low altitude.

## EVAPORATIVE EMISSION PURGE CONTROL VALVE INSPECTION (CALIFORNIA TYPE ONLY)

*The evaporative emission purge control valve should be inspected if hot restart is difficult.* Check all fuel tank, Evaporative Emission Purge Control Valve (EVAP PURGE CONTROL VALVE), and evaporative emission canister hoses to be sure they are not kinked and are securely connected. Replace any hose that shows signs of damage or deterioration.

*The EVAP PURGE CONTROL VALVE is located under the fuel tank.* Disconnect the EVAP PURGE CONTROL VALVE hoses from their connections and remove the EVAP PURGE CONTROL VALVE from its mount. Refer to the routing label on the inside of the left side cover for hose connections.

**NEW** '97-'99 Refer to the routing label on the inside of the left side cover for hose connection.

**NEW** After '99 Refer to the routing label on the frame pipe under the fuel tank for hose connection.

After '99 **NEW** VEHICLE EMISSION CONTROL INFORMATION UPDATE LABEL

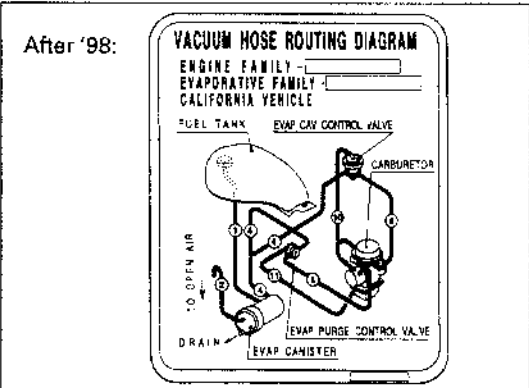
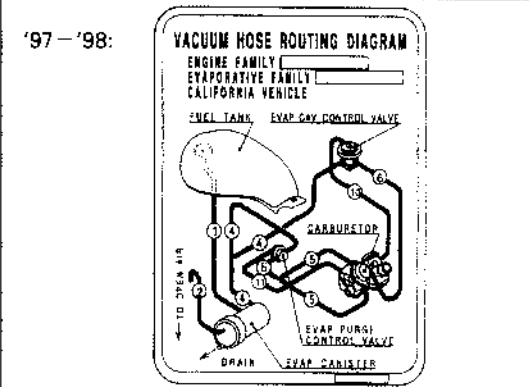
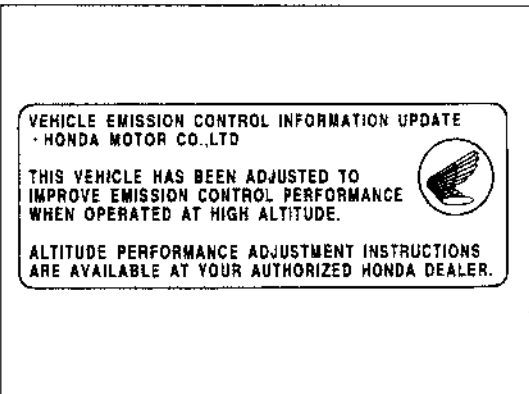
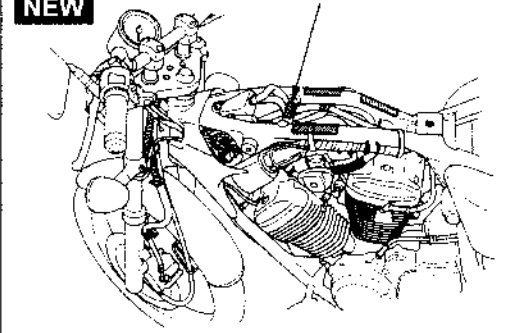

## FUEL SYSTEM

Connect the vacuum pump to the No. 10 hose that goes to the right carburetor body ('97-'98)/goes to the 3-way joint (After '98).

Connect the pressure pump to the air vent port of the EVAP CAV CONTROL VALVE.

While applying the vacuum to the EVAP CAV CONTROL VALVE No. 10 hose that goes to the right carburetor body ('97-'98)/goes to the 3-way joint (After '98), pump air through the EVAP CAV CONTROL VALVE and out the hose that goes to the carburetor air joint pipe ('97-'98)/goes to the carburetor body (After '98).

### TOOL:

<b>Vacuum/pressure pump</b>	A937-041-XXXXX or
<b>Vacuum pump</b>	ST-AH-260-MC7
<b>Pressure pump</b>	ST-AH-255-MC7

Plug the hose that goes to the carburetor air joint pipe ('97-'98)/goes to the carburetor body (After '98).

While applying vacuum to the EVAP CAV CONTROL VALVE No. 10 hose that goes to the right carburetor body ('97-'98)/goes to the 3-way joint (After '98), apply air pressure.

Remove the pumps, install the EVAP CAV CONTROL VALVE on its mount, route and reconnect the hoses according to the routing label.

### TOOL:

<b>Vacuum/pressure pump</b>	A937-041-XXXXX or
<b>Vacuum pump</b>	ST-AH-260-MC7
<b>Pressure pump</b>	ST-AH-255-MC7

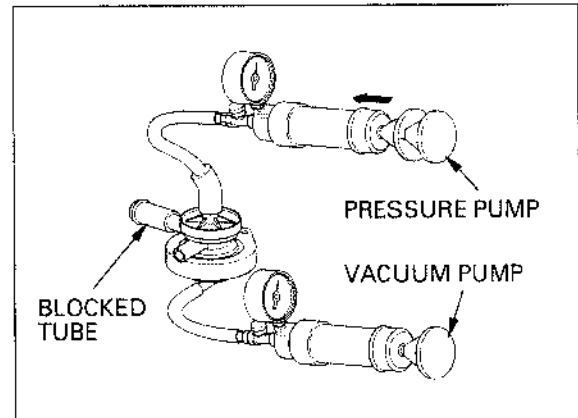
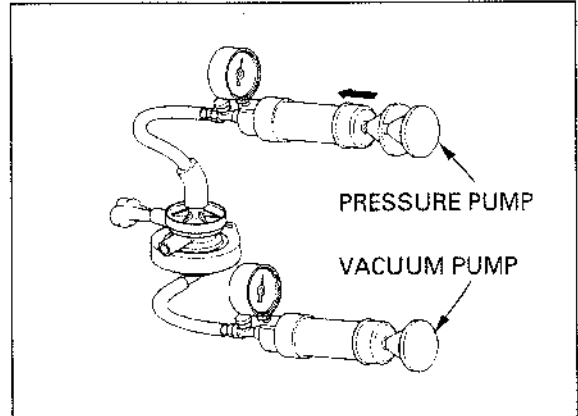

---

**NOTE**

---

## COOLING SYSTEM

---

### SYSTEM FLOW PATTERN

'97-'98:

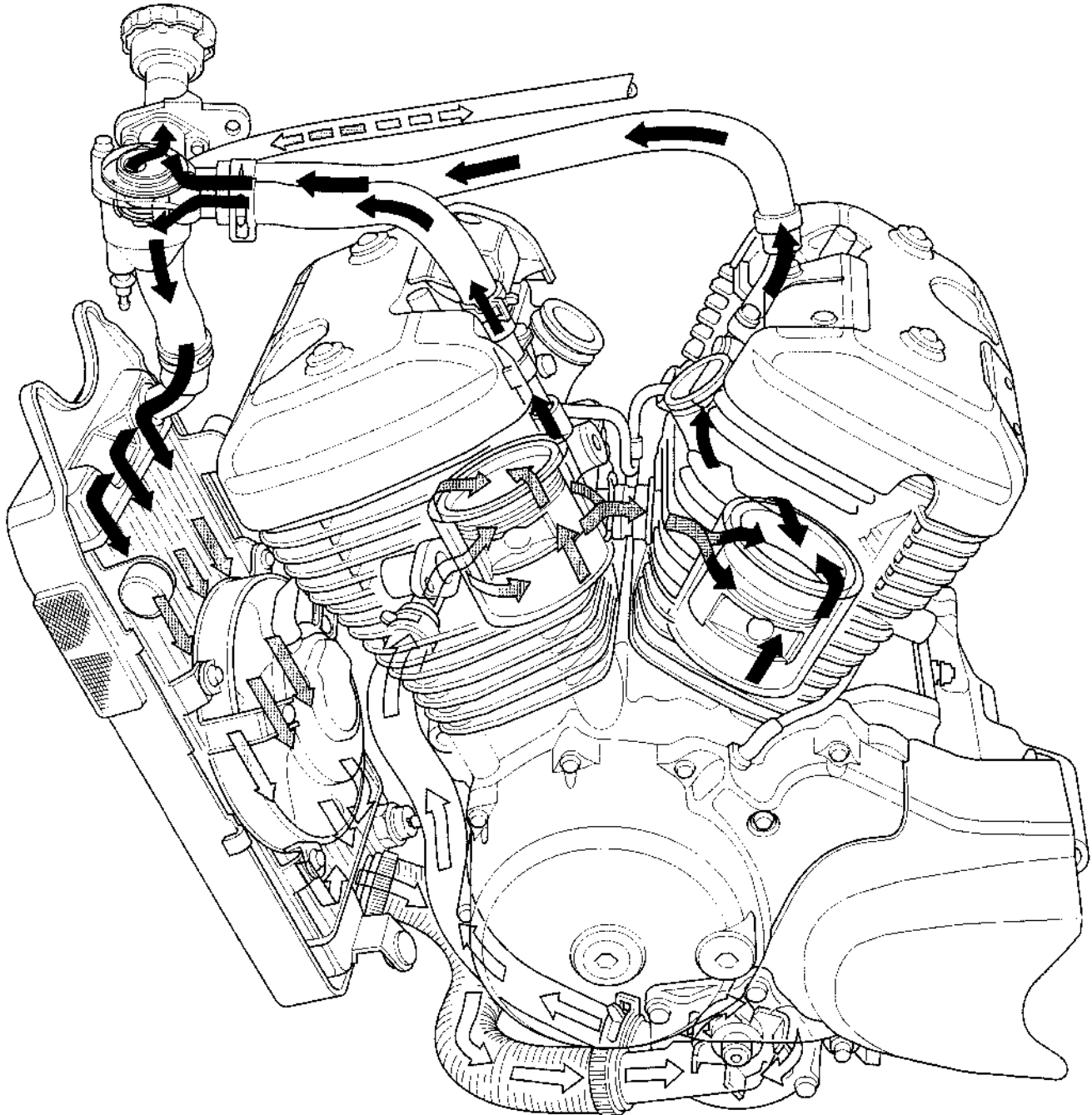

# 6. COOLING SYSTEM

SERVICE INFORMATION	6-2	THERMOSTAT	6-7
TROUBLESHOOTING	6-3	RADIATOR/COOLING FAN	6-9
SYSTEM TESTING	6-4	WATER PUMP	6-15
COOLANT	6-5	RADIATOR RESERVE TANK	6-18

After '98:

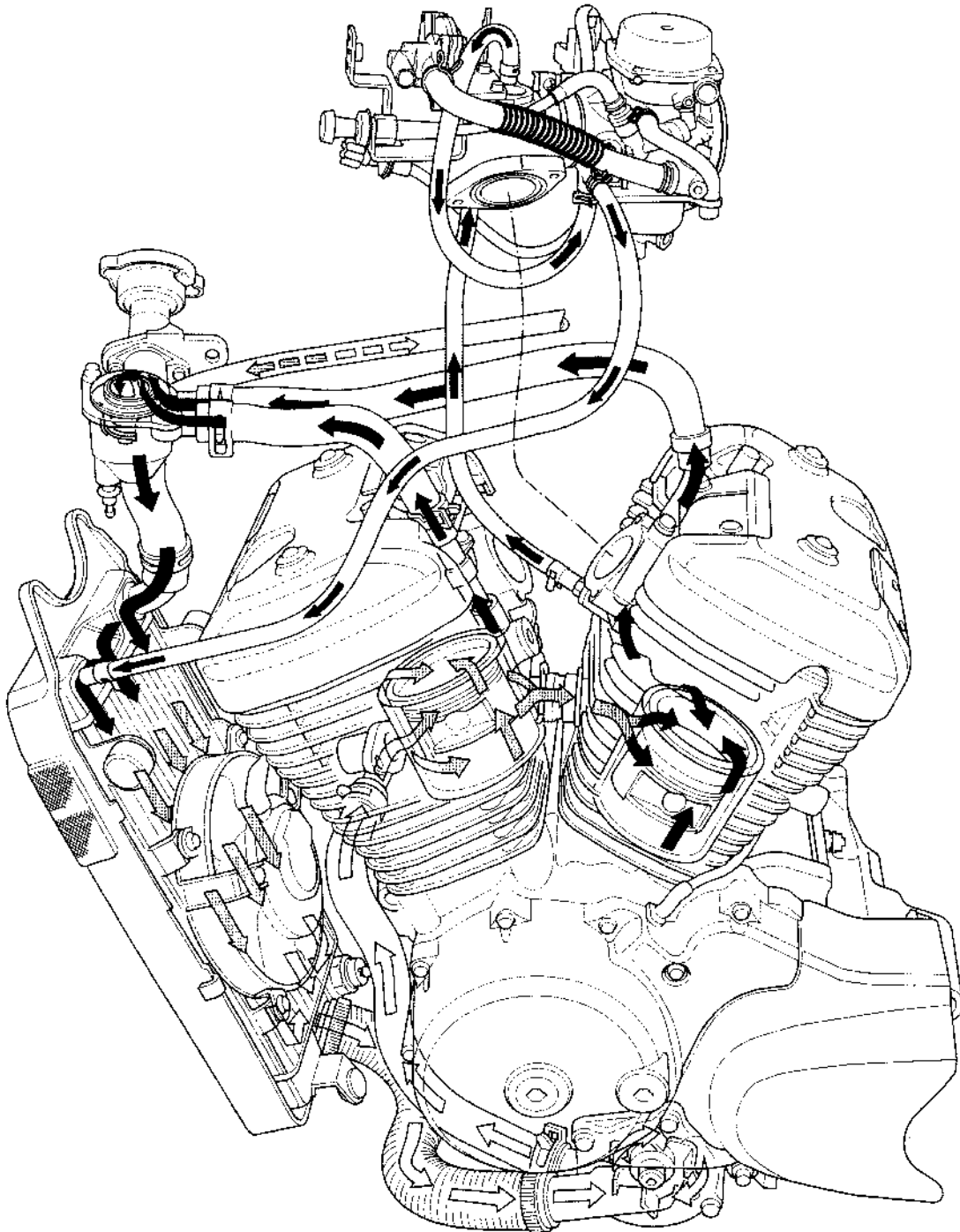

## SERVICE INFORMATION

### GENERAL

#### ▲WARNING

- *Wait until the engine is cool before slowly removing the radiator cap. Removing the cap while the engine is hot and the coolant is under pressure may cause serious scalding.*
- *Radiator coolant is toxic. Keep it away from eyes, mouth, skin and clothes.*
  - *If any coolant gets in your eyes, rinse them with water and consult a doctor immediately.*
  - *If any coolant is swallowed, induce vomiting, gargle and consult a physician immediately.*
  - *If any coolant gets on your skin or clothes, rinse thoroughly with plenty of water.*
- **KEEP OUT OF REACH OF CHILDREN.**

- Use only distilled water and ethylene glycol in the cooling system. A 50-50 mixture is recommended for maximum corrosion protection. Do not use alcohol-based antifreeze or an antifreeze with self sealing properties.
- Add coolant at the reserve tank. Do not remove the radiator cap except to refill or drain the system.
- All cooling system services can be done with the engine in the frame.
- Avoid spilling coolant on painted surfaces.
- After servicing the system, check for leaks with a cooling system tester.
- Refer to Section 19 for fan motor switch and thermosensor ('97-'00)/thermo switch (After '00) inspection. **NEW**

### SPECIFICATIONS

ITEM		SPECIFICATIONS
Cooling capacity	Radiator and engine	1.6 ℓ (1.7 US qt , 1.4 Imp qt)
	Reserve tank	0.4 ℓ (0.4 US qt , 0.4 Imp qt)
Radiator cap relief pressure		88 – 127 kPa (0.9 – 1.3 kgf/cm <sup>2</sup> , 12.8 – 18 psi)
Thermostat	Begin to open	80 – 84 °C (176 – 183 °F)
	Fully open	95 °C (203 °F)
	Valve lift	8 mm (0.3 in) minimum
Standard coolant concentration		50 % mixture with soft water

### TORQUE VALUES

Radiator mounting bolt	9 N·m (0.9 kgf·m , 6.5 lbf·ft)	
Radiator grille mounting screw	9 N·m (0.9 kgf·m , 6.5 lbf·ft)	
Thermostat bracket bolt	10 N·m (1.0 kgf·m , 7 lbf·ft)	
Thermostat housing cover bolt	10 N·m (1.0 kgf·m , 7 lbf·ft)	
Thermo sensor ('97 – '00)	10 N·m (1.0 kgf·m , 7 lbf·ft)	Apply sealant to the threads
Thermo switch (After '00)	8 N·m (0.8 kgf·m , 5.8 lbf·ft)	Apply sealant to the threads <b>NEW</b>
Water hose band screw	7 N·m (0.7 kgf·m , 5.1 lbf·ft)	
Fan motor switch	18 N·m (1.8 kgf·m , 13 lbf·ft)	Apply sealant to the threads

### TOOLS

Pressure pump	Equivalent commercially available
---------------	-----------------------------------



## TROUBLESHOOTING

### Engine temperature too high

- Faulty temperature gauge or thermo sensor (Section 19)
- Faulty radiator cap
- Insufficient coolant
- Passages blocked in radiator, hoses or water jacket
- Air in system
- Faulty water pump
- Thermostat stuck closed
- Faulty cooling fan motor
- Faulty fan motor switch

### Engine temperature too low

- Faulty temperature gauge or thermo sensor (Section 19)
- Thermostat stuck open
- Faulty cooling fan motor switch

### Coolant leaks

- Faulty water pump mechanical seal
- Deteriorated O-ring
- Damaged or deteriorated gasket
- Loose hose connection or clamp
- Damaged or deteriorated hose
- Faulty radiator cap

SYSTEM TESTING

COOLANT (HYDROMETER TEST)

**▲WARNING**

*Be sure the engine is cool before removing the cap or you may be severely scalded.*

Remove the steering covers (page 2-3).

Remove the radiator cap.

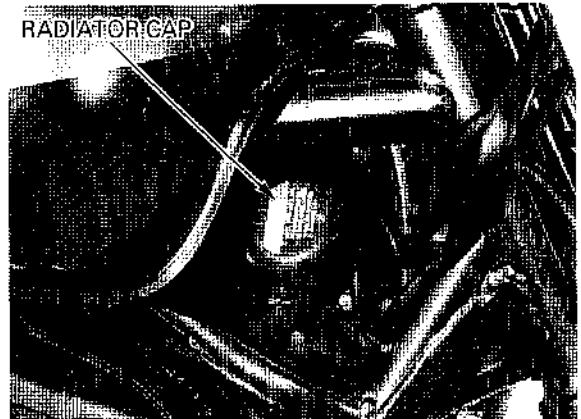

Check the coolant gravity using a hydrometer.

**STANDARD COOLANT CONCENTRATION: 50 %**

Look for contamination and replace the coolant if necessary.

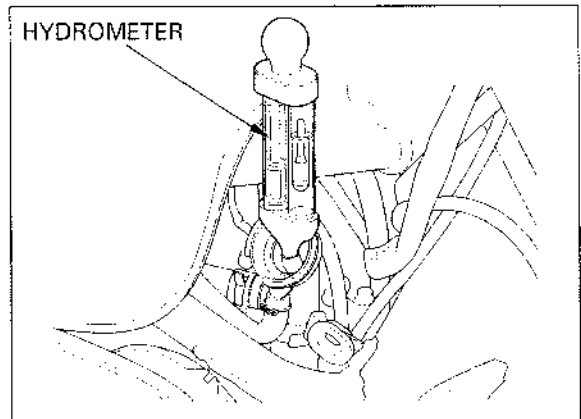

Coolant specific gravity chart

Coolant temperature °C (°F)	0 (32)	5 (41)	10 (50)	15 (59)	20 (68)	25 (77)	30 (86)	35 (95)	40 (104)	45 (113)	50 (122)
Coolant ratio %											
5	1.009	1.009	1.008	1.008	1.007	1.006	1.005	1.003	1.001	0.999	0.997
10	1.018	1.017	1.017	1.016	1.015	1.014	1.013	1.011	1.009	1.007	1.005
15	1.028	1.027	1.026	1.025	1.024	1.022	1.020	1.018	1.016	1.014	1.012
20	1.036	1.035	1.034	1.033	1.031	1.029	1.027	1.025	1.023	1.021	1.019
25	1.045	1.044	1.043	1.042	1.040	1.038	1.036	1.034	1.031	1.028	1.025
30	1.053	1.052	1.051	1.049	1.047	1.045	1.043	1.041	1.038	1.035	1.032
35	1.063	1.062	1.060	1.058	1.056	1.054	1.052	1.049	1.046	1.043	1.040
40	1.072	1.070	1.068	1.066	1.064	1.062	1.059	1.056	1.053	1.050	1.047
45	1.080	1.078	1.076	1.074	1.072	1.069	1.066	1.063	1.060	1.057	1.054
50	1.086	1.084	1.082	1.080	1.077	1.074	1.071	1.068	1.065	1.062	1.059
55	1.095	1.093	1.091	1.088	1.085	1.082	1.079	1.076	1.073	1.070	1.067
60	1.100	1.098	1.095	1.092	1.089	1.086	1.083	1.080	1.077	1.074	1.071

## RADIATOR CAP/SYSTEM PRESSURE INSPECTION

### ▲WARNING

*The engine must be cool before removing the radiator cap, or severe scalding may result.*

Remove the steering covers (page 2-3).  
Remove the radiator cap.

*Before installing the cap in the tester, wet the sealing surface.*

Pressure test the radiator cap. Replace the radiator cap if it does not hold pressure, or if relief pressure is too high or too low. It must hold specified pressure for at least 6 seconds.

### RADIATOR CAP RELIEF PRESSURE:

88 – 127 kPa (0.9 – 1.3 kgf/cm<sup>2</sup>, 12.8 – 18 psi)

Pressure the radiator, engine and hoses, and check for leaks.

### CAUTION:

*Excessive pressure can damage the cooling system components. Do not exceed 127 kPa (1.3 kgf/cm<sup>2</sup>, 18.5 psi).*

Check the following components if the system will not hold specified pressure for at least 6 seconds.

- All hose and connections
- Water pump installation
- Water pump seal (for leakage)
- Deformed radiator filler neck

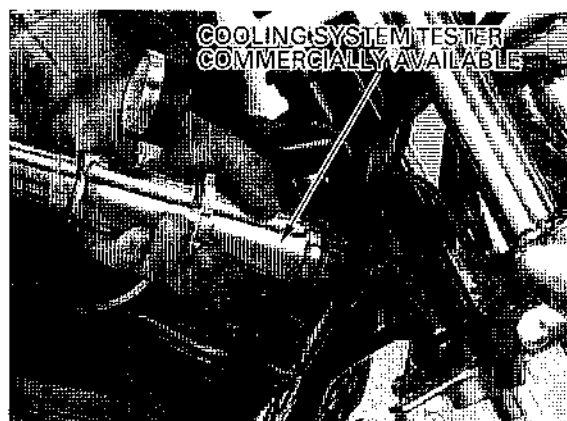
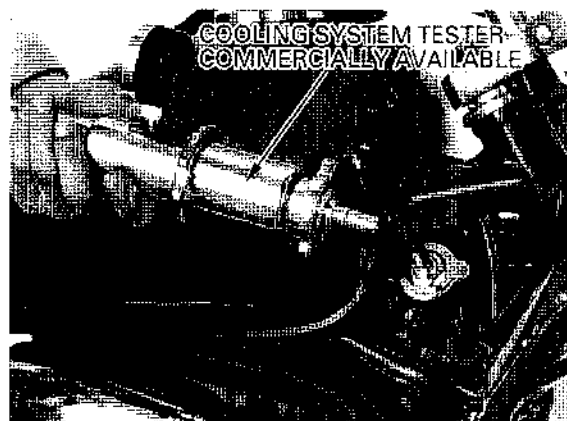

## COOLANT

### ▲WARNING

- *Radiator coolant is toxic. Keep it away from eyes, mouth, skin and clothes.*
  - *If any coolant gets in your eyes, rinse them with water and consult a doctor immediately.*
  - *If any coolant is swallowed, induce vomiting, gargle and consult a physician immediately.*
  - *If any coolant gets on your skin or clothes, rinse thoroughly with plenty of water.*
- **KEEP OUT OF REACH OF CHILDREN.**

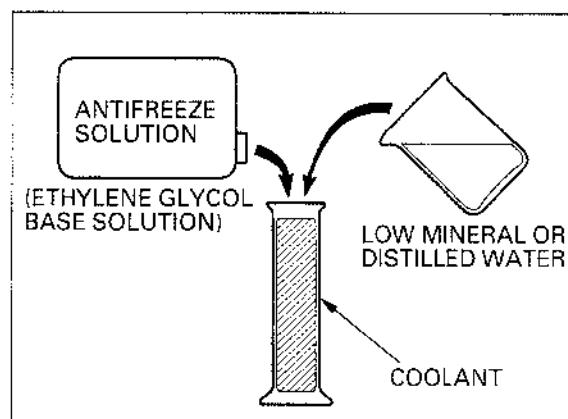

## COOLING SYSTEM

### NOTE:

- The effectiveness of coolant decreases with the accumulation of rust or if there is a change in the mixing proportion during usage. Therefore, for best performance change the coolant regularly as specified in the maintenance schedule.
- Mix only distilled, low mineral water with the antifreeze.

### RECOMMENDED MIXTURE:

50—50 (Distilled water and antifreeze)

## REPLACEMENT/AIR BLEEDING

### ⚠WARNING

*The engine must be cool before removing the radiator cap, or severe scalding may result.*

### NOTE:

When filling the system or reserve tank with a coolant (checking the coolant level), place the motorcycle in a vertical position on a flat, level surface.

Remove the steering covers (page 2-3).  
Remove the radiator cap.

Drain the coolant from the system by removing the drain bolt and sealing washer on the water pump cover.

Remove the rear cylinder coolant drain bolt and drain the coolant using a funnel as shown.

Reinstall and tighten the drain bolt securely with a new sealing washer.

Remove the reserve tank (page 6-18).

Remove the reserve tank cap from the reserve tank and drain the reserve coolant.

Empty the coolant and rinse the inside of the reserve tank with water.

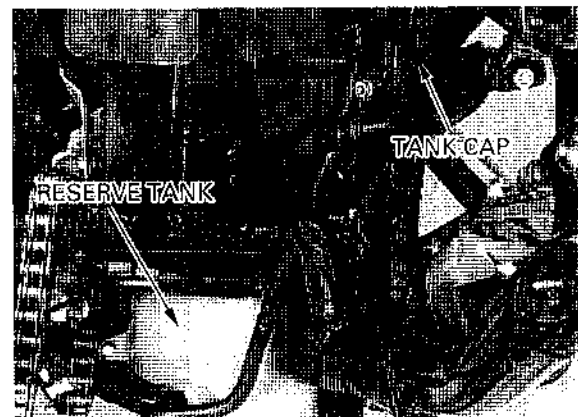
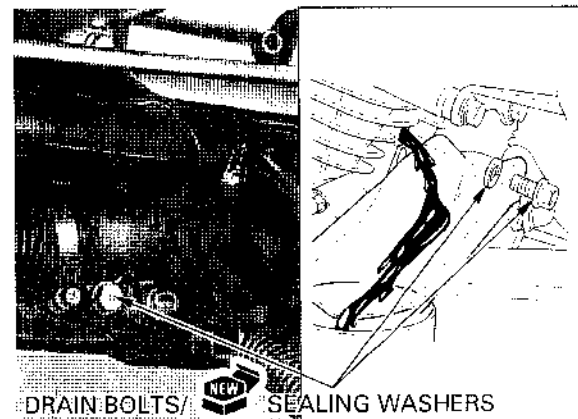
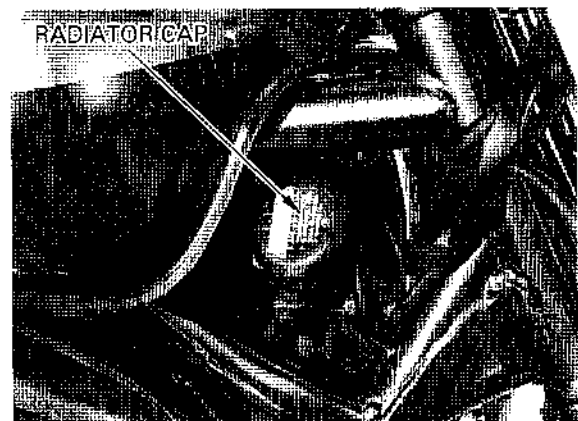

Install the reserve tank (page 6-18).

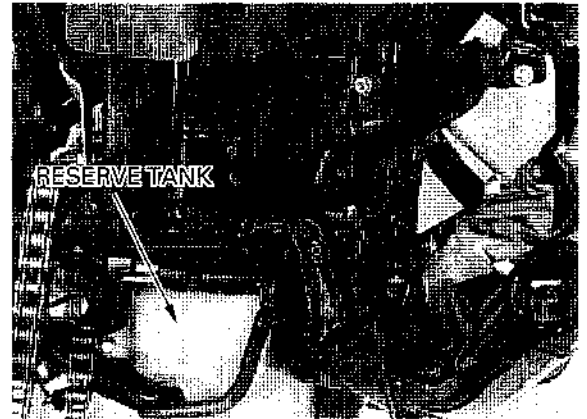

Using the filler opening, fill the system with the recommended coolant up to filler neck. Remove the reserve tank cap and fill the reserve tank to the upper level line.

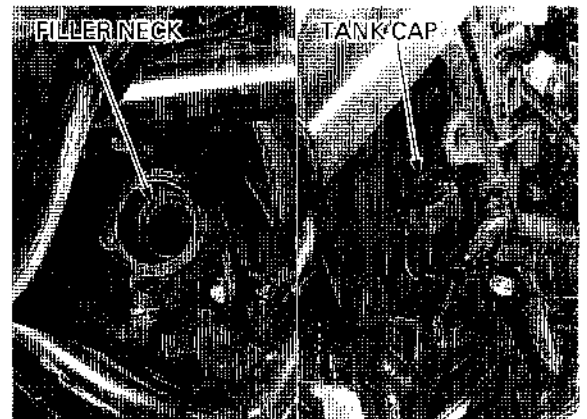

Bleed air from the system as follows:

1. Shift the transmission into neutral.  
Start the engine and let it idle for 2 – 3 minutes.
2. Snap the throttle 3 – 4 times to bleed air from the system.
3. Stop the engine and add coolant up to the filler neck. Reinstall the radiator cap.
4. Check the level of coolant in the reserve tank and fill to the upper level if it is low.

## THERMOSTAT

### REMOVAL

Remove the following:

- Fuel tank (page 2-4)
- Air cleaner housing (page 5-4)
- Drain the coolant (page 6-6).

Remove the thermostat housing and radiator filler mounting bolts.

Disconnect the siphon tube from the radiator filler. Disconnect the upper radiator hose at the radiator and remove the filler and radiator hose from the frame.

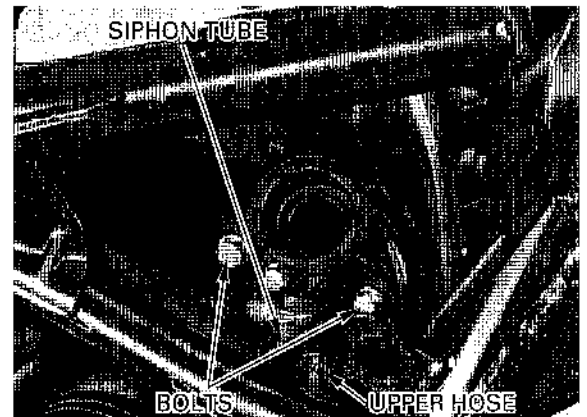

Remove the bolts and thermostat housing cover.

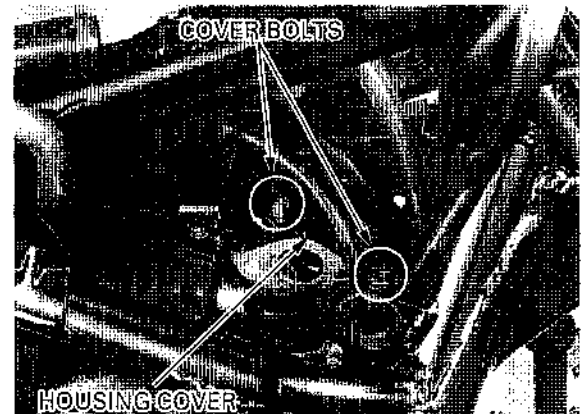

## COOLING SYSTEM

Remove the thermostat from the housing.

Coolant temperature, thermosensor inspection and removal (page 19-13).

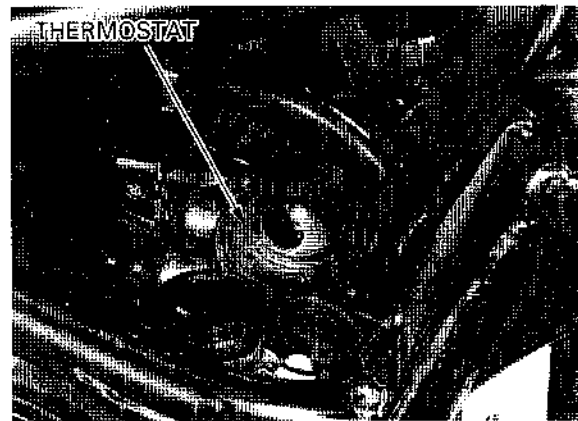

### INSPECTION

#### ▲WARNING

- *Wear insulated gloves and adequate eye protection.*
- *Keep flammable materials away from the electric heating element.*

#### NOTE:

- Do not let the thermostat or thermometer touch the pan, or you will get false readings.
- Replace the thermostat if valve stays open at room temperature, or if it responds at temperatures other than those specified.

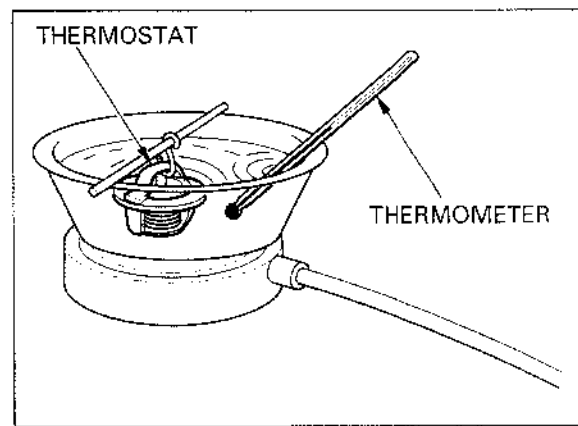

Visually inspect the thermostat for damage.

Heat the water with an electric heating element to operating temperature for 5 minutes.  
Suspend the thermostat in heated water to check its operation.

#### THERMOSTAT BEGINS TO OPEN:

80–84 °C (176–183 °F)

#### VALVE LIFT:

8 mm (0.3 in) minimum at 95 °C (203 °F)

### INSTALLATION

Install the thermostat into the housing.

#### NOTE:

Install the thermostat with its hole facing up and fit it properly in the housing.

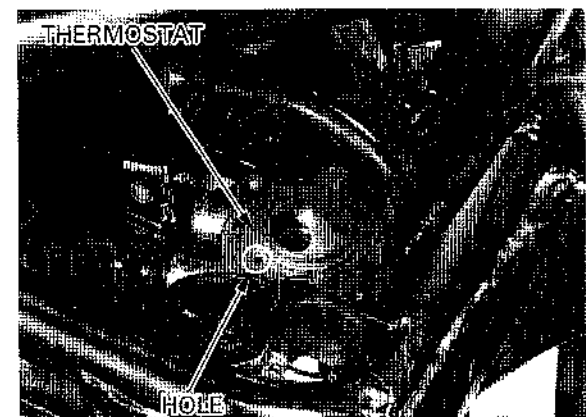

Install a new O-ring on the housing cover and install the housing cover onto the housing.

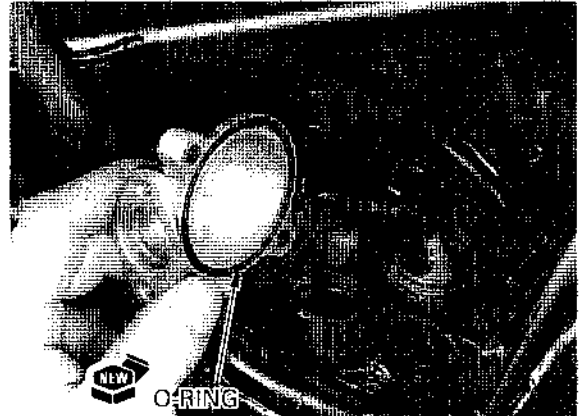

Be sure to secure the thermostat ground wire with the cover mounting bolt as shown.

Install and tighten the thermostat housing cover mounting bolts to the specified torque.

**TORQUE:** 10 N·m (1.0 kgf·m , 7 lbf·ft)

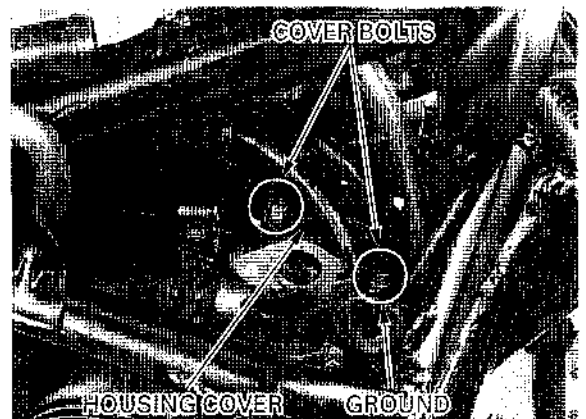

Install a new O-ring on the radiator filler, and connect the upper radiator hose and siphon tube to the radiator filler.

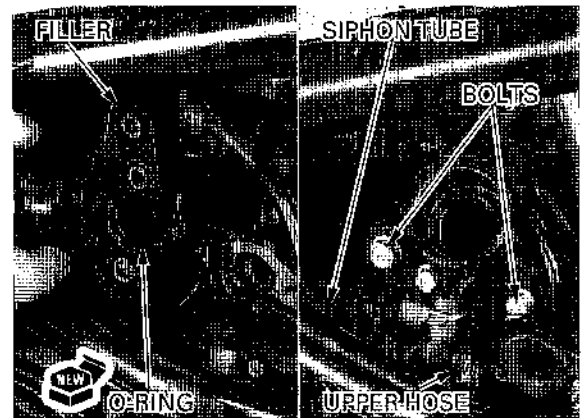

Install the radiator filler onto the thermostat housing.

Tighten the filler and thermostat housing mounting bolts.

- Install the following:
- Air cleaner housing (page 5-5)
  - Fuel tank (page 2-7)

Fill and bleed the cooling system (page 6-7).

## RADIATOR/COOLING FAN

### CAUTION:

*Be careful not to damage the radiator fins.*

### REMOVAL

- Drain the coolant (page 6-6).
- Remove the fuel tank (page 2-4).
- Disconnect the fan motor 2P (black) connector.

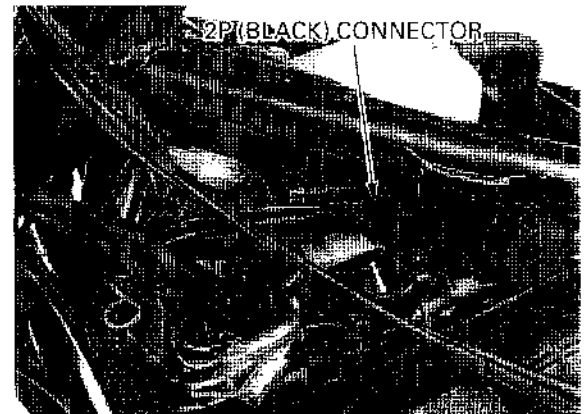

## COOLING SYSTEM

Disconnect the horn wires and remove the horn mounting bolt and horn ('97 - '98).

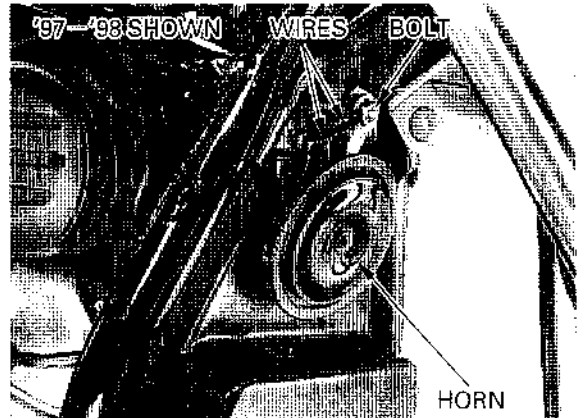

Remove the radiator mounting bolt.

Loosen the hose band and disconnect the lower radiator hose from the radiator.

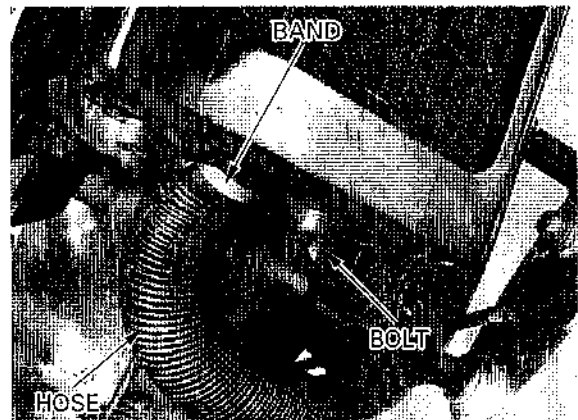

'97 - '98: Unhook the radiator mount rubbers from the frame stays.

Unclamp the hose band and disconnect the upper radiator hose from the radiator.  
Remove the radiator.

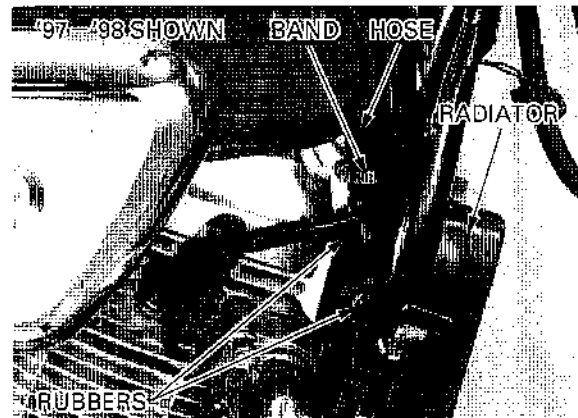

After '98: Unhook the radiator mount rubbers from the frame stays.

Loosen the hose band and disconnect the upper radiator hose.  
Unclamp the tube band and disconnect the water tube.

Remove the radiator.

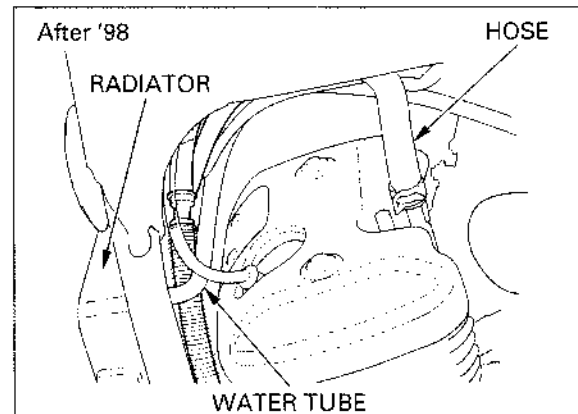



**DISASSEMBLY**

Remove the radiator grille mounting screw and radiator shroud.

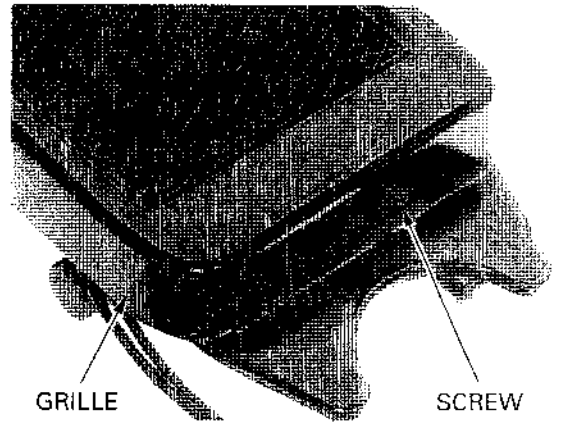

Disconnect the fan motor switch connector.  
Remove the wires from the clamp.

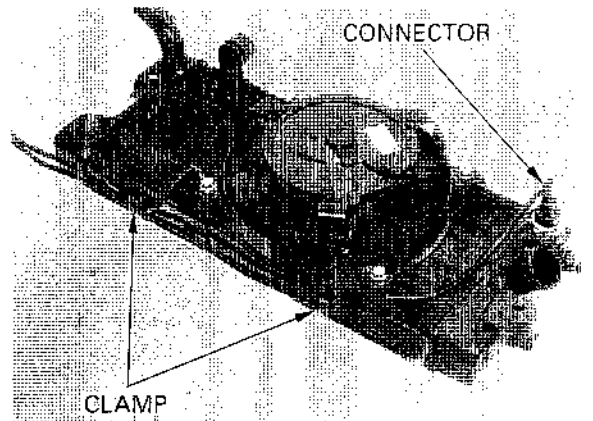

Remove the bolts and ground terminal.  
Remove the cooling fan assembly from the radiator.

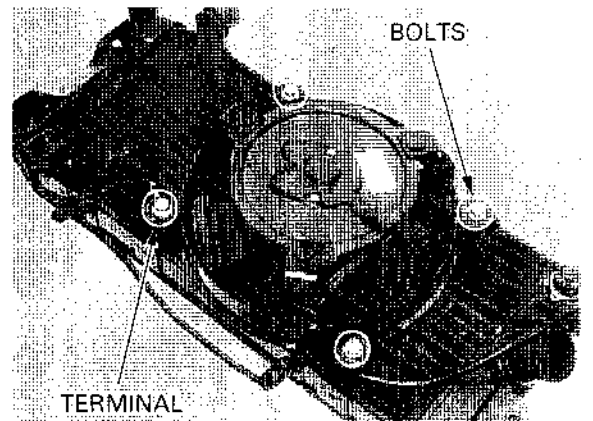

Remove the nut and cooling fan.

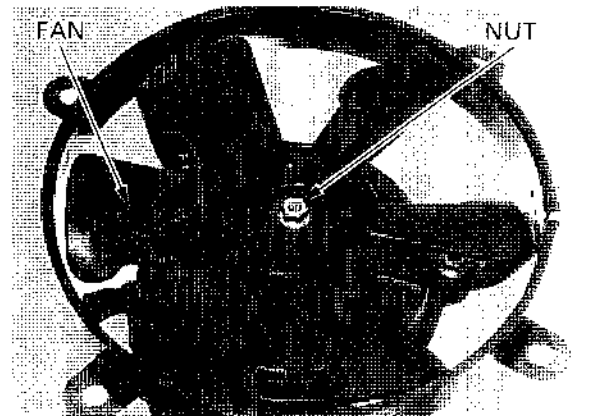

## COOLING SYSTEM

Remove the nuts and fan motor from the shroud.

The fan motor switch removal and inspection procedure is described on page 19-12.

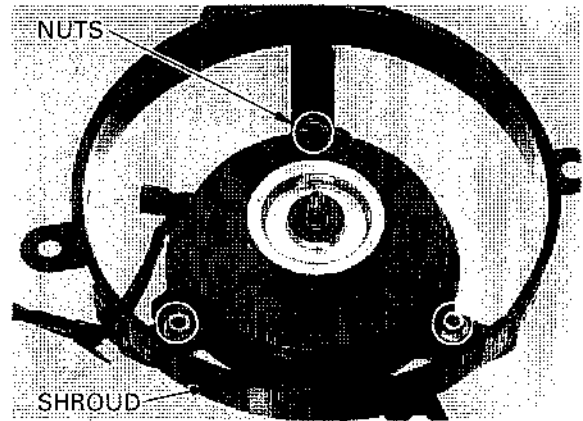

## ASSEMBLY

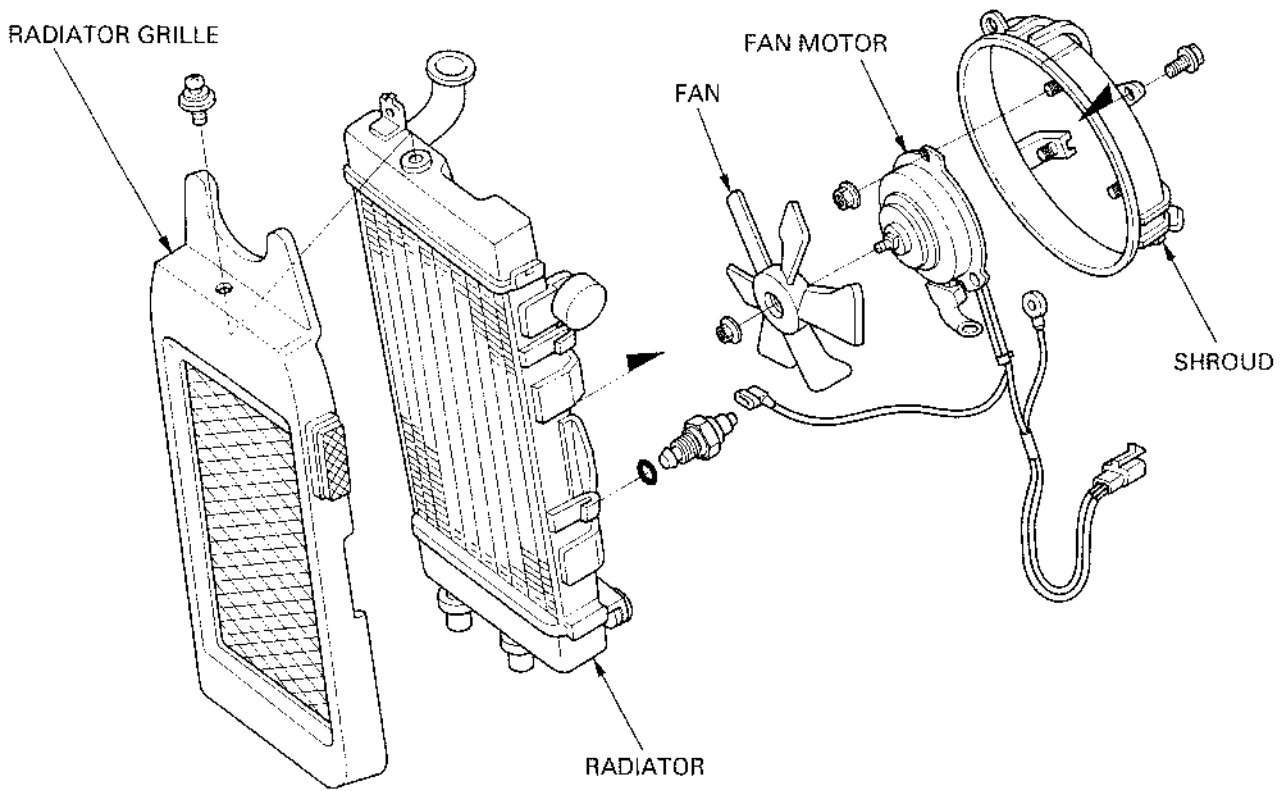

*Install the fan motor to the shroud with the drain tube direction as shown.*

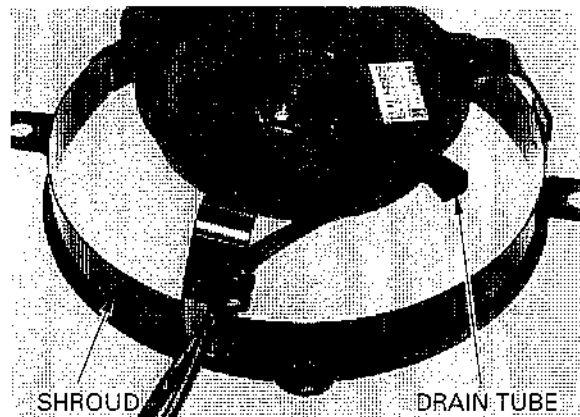

Install and tighten the nuts securely.

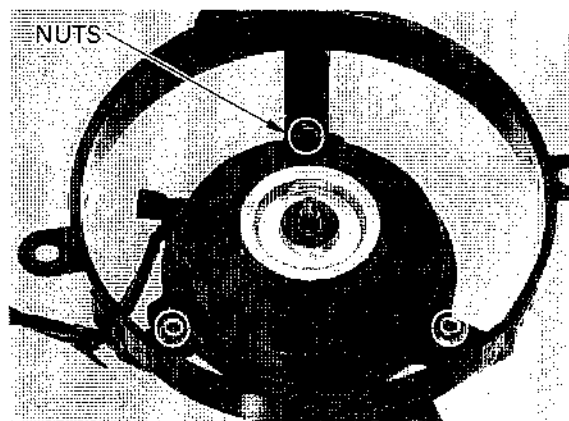

Install the cooling fan onto the motor shaft by aligning the flat surfaces.

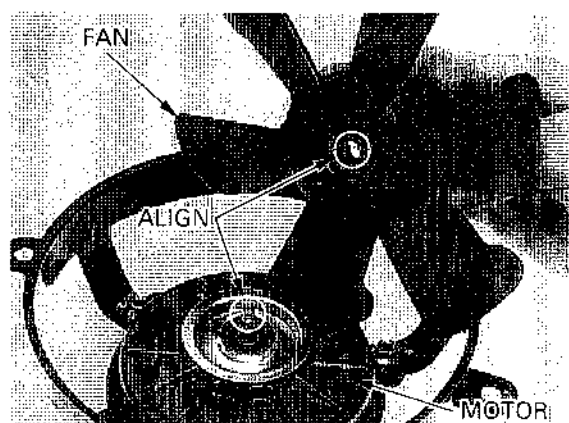

Tighten the nut securely.

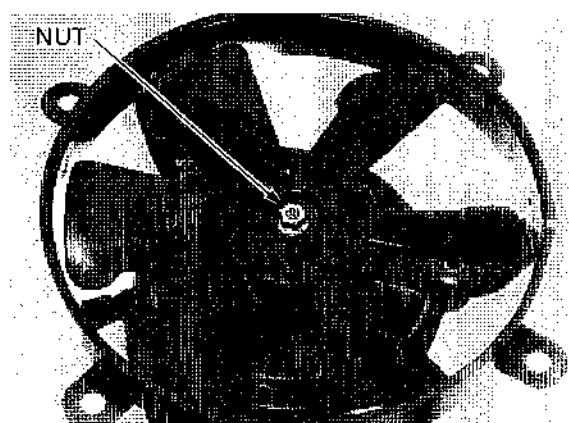

Install the cooling fan assembly to the radiator. Tighten the bolts securely with the ground terminal.

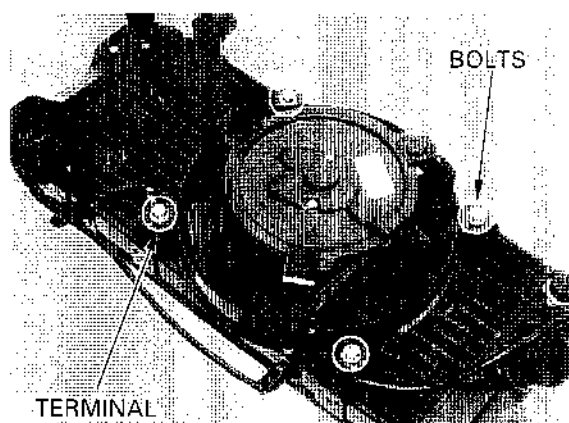

## COOLING SYSTEM

Connect the fan motor switch connector.

Route the ground wire and fan motor switch wire properly, clamp the wires.

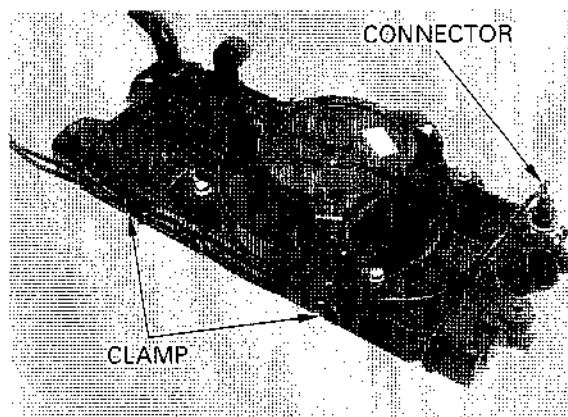

Install the radiator grille.  
Install and tighten the screw to the specified torque.

**TORQUE:** 9 N·m (0.9 kgf·m , 6.5 lbf·ft)

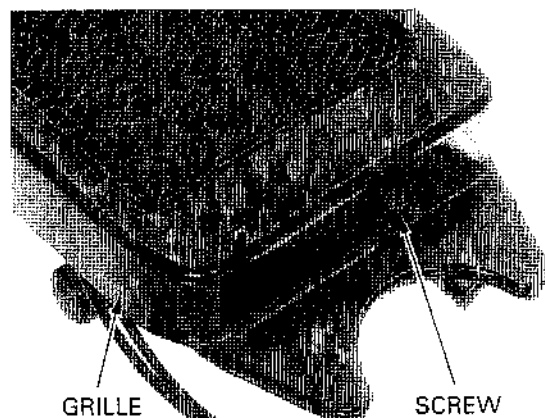

## INSTALLATION

'97-'98: Connect the upper radiator hose and clamp the radiator hose band to the radiator.

Hook the radiator mount rubbers to the frame stays.

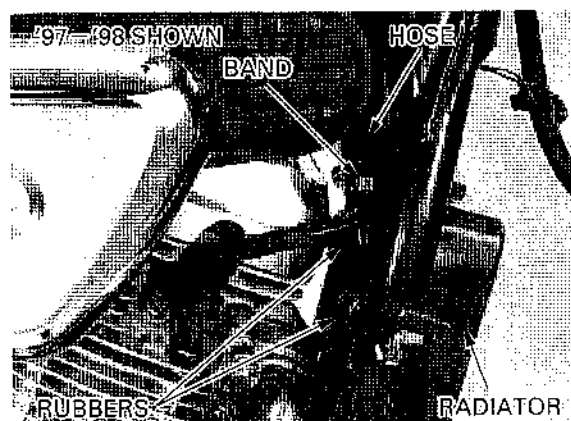

After '98: Connect the upper radiator hose and tighten the radiator hose band screw.  
Connect the water tube and clamp the water tube band.

Hook the radiator mount rubbers to the frame stays.

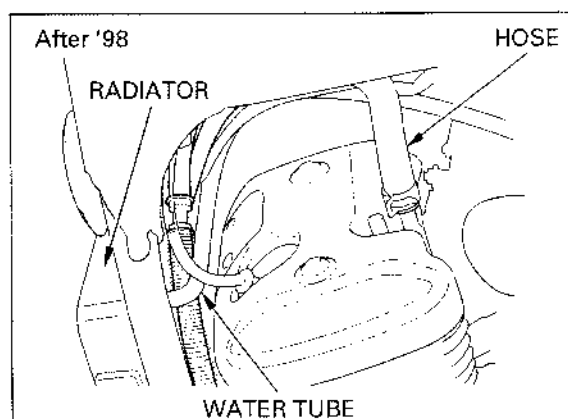

Connect the lower radiator hose and tighten the radiator hose band screw to the specified torque.

**TORQUE:** 7 N·m (0.7 kgf·m , 5.1 lbf·ft)

Install and tighten the radiator mounting bolt to the specified torque.

**TORQUE:** 9 N·m (0.9 kgf·m , 6.5 lbf·ft)

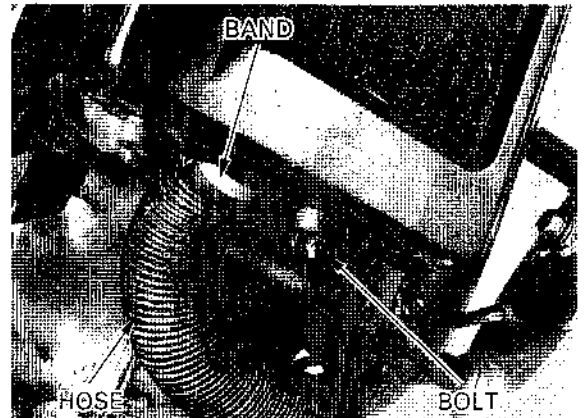

Install the horn and tighten the mounting bolt to the specified torque.

**TORQUE:** 26 N·m (2.7 kgf·m , 20 lbf·ft)

Connect the horn wires.

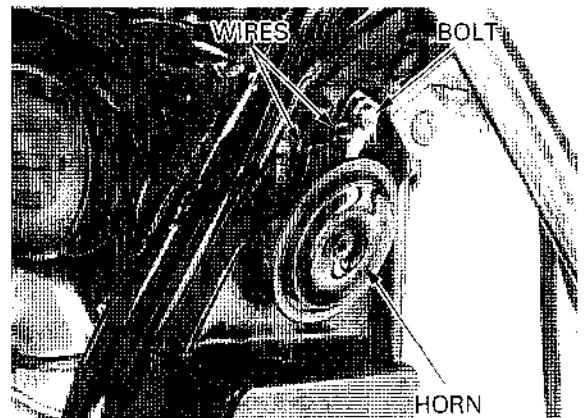

Connect the fan motor 2P (black) connector.

Install the steering covers (page 2-3).

Install the fuel tank (page 2-4).

Fill and bleed the cooling system (page 6-7).

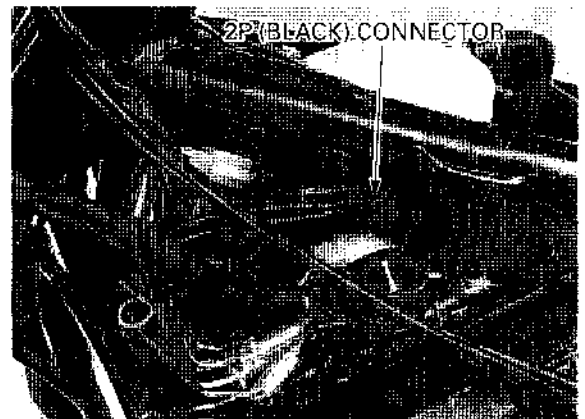

## WATER PUMP

### MECHANICAL SEAL INSPECTION

**NOTE:**

The water pump cover and O-ring can be removed with engine in the frame.

Inspect the telltale hole for signs of coolant leakage. If there is leakage, the mechanical seal is defective and the water pump assembly must be replaced.

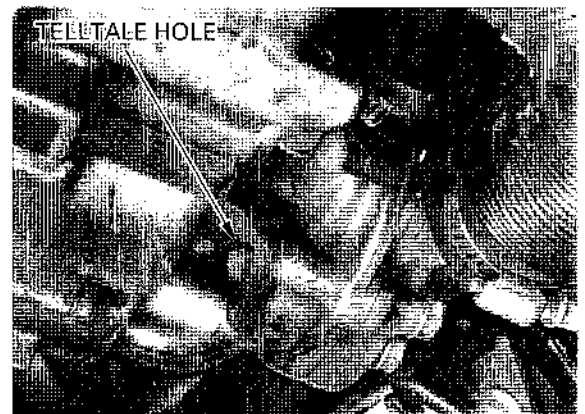

## COOLING SYSTEM

### REMOVAL

Remove the engine from the frame (section 7).

Remove the water pump cover mounting bolts and cover.

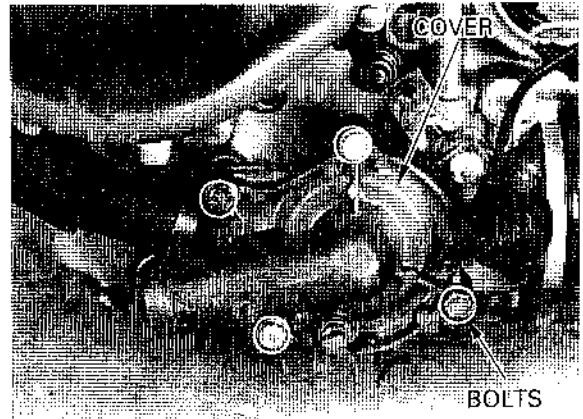

Remove the O-ring and dowel pins from the water pump assembly and disconnect the water hose.

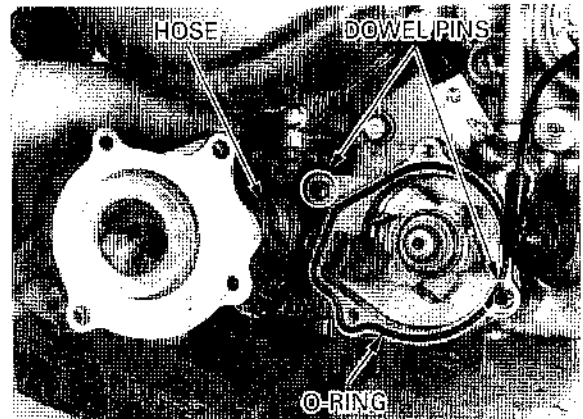

*Do not disassemble the water pump.* Remove the water pump and O-ring from the crankcase.

*Replace the pump as an assembly if it is damaged.*

### INSPECTION

Check the water pump for mechanical seal leakage and bearing deterioration. Replace the water pump as an assembly if necessary.

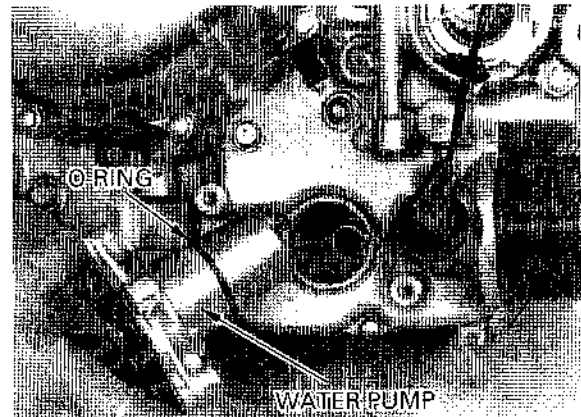

INSTALLATION

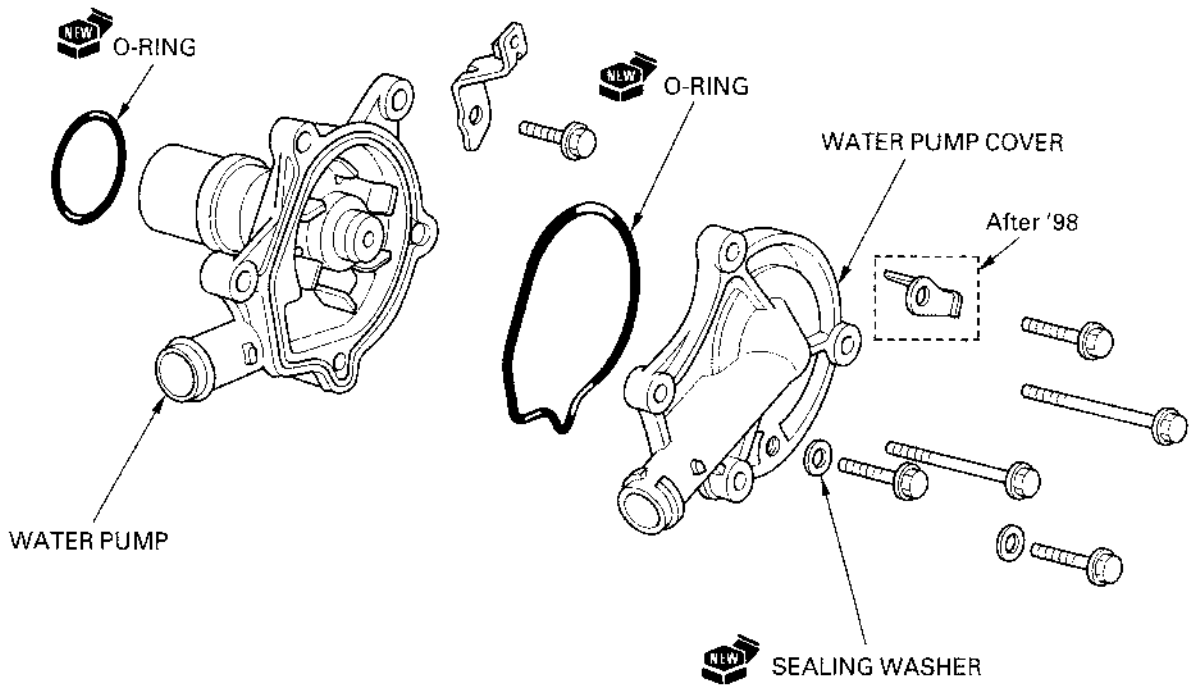

Apply a coat of clean engine oil to a new O-ring and install it in the water pump shaft housing groove.

Align the water pump shaft groove with the oil pump shaft and insert the water pump into the crankcase.

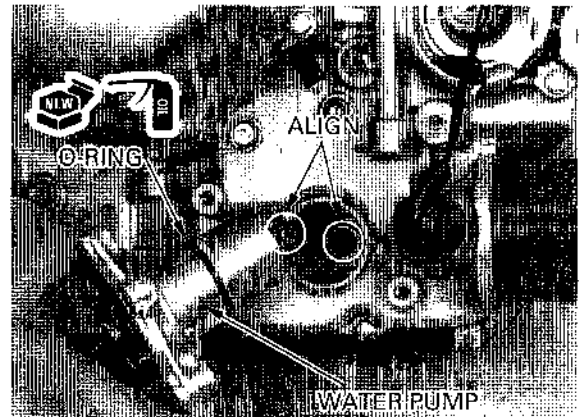

Connect the water hose to the water pump assembly and clamp the hose band securely.

Apply a coat of clean engine oil to a new O-ring and install it around the impeller housing. Install the dowel pins.

Install the water pump cover to the water pump.

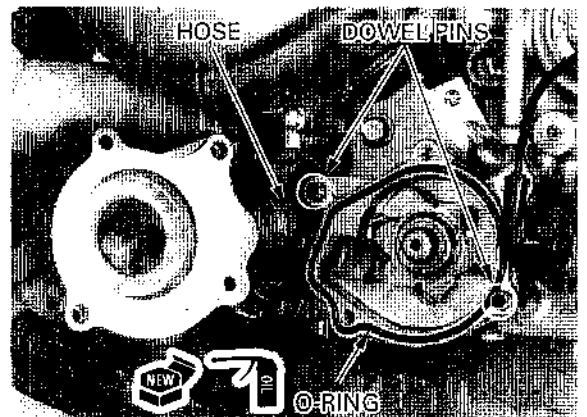

## COOLING SYSTEM

Install and tighten the cover bolts securely.

Install the engine in the frame (section 7).

Fill and bleed the cooling system (page 6-7).  
Fill the engine with the recommended engine oil (page 3-14).

Check the cooling system for leakage.

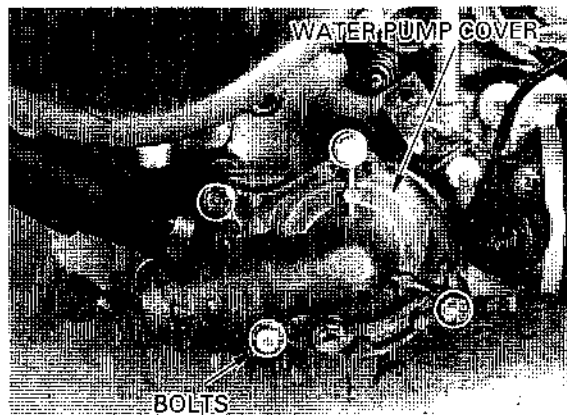

## RADIATOR RESERVE TANK

### REMOVAL/INSTALLATION

*The radiator reserve tank can be serviced with the rear wheel in the swingarm.*

Raise and support the motorcycle rear frame using a hoist or jack under the engine.

#### CAUTION:

***Do not support the motorcycle using oil filter.***

Remove the evaporative emission canister (California type only).

Place a suitable container under the siphon tube joint of the reserve tank.

Disconnect the radiator siphon tube and overflow tube at the reserve tank.

Remove the reserve tank mounting bolt, filler mounting nut and reserve tank.

Installation is in the reverse order of removal.

Fill the reserve tank with coolant (page 6-7).

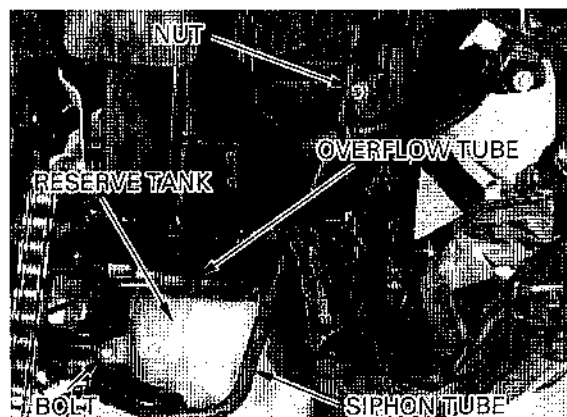



---

**MEMO**

---

# ENGINE REMOVAL/INSTALLATION

'97 - '98:

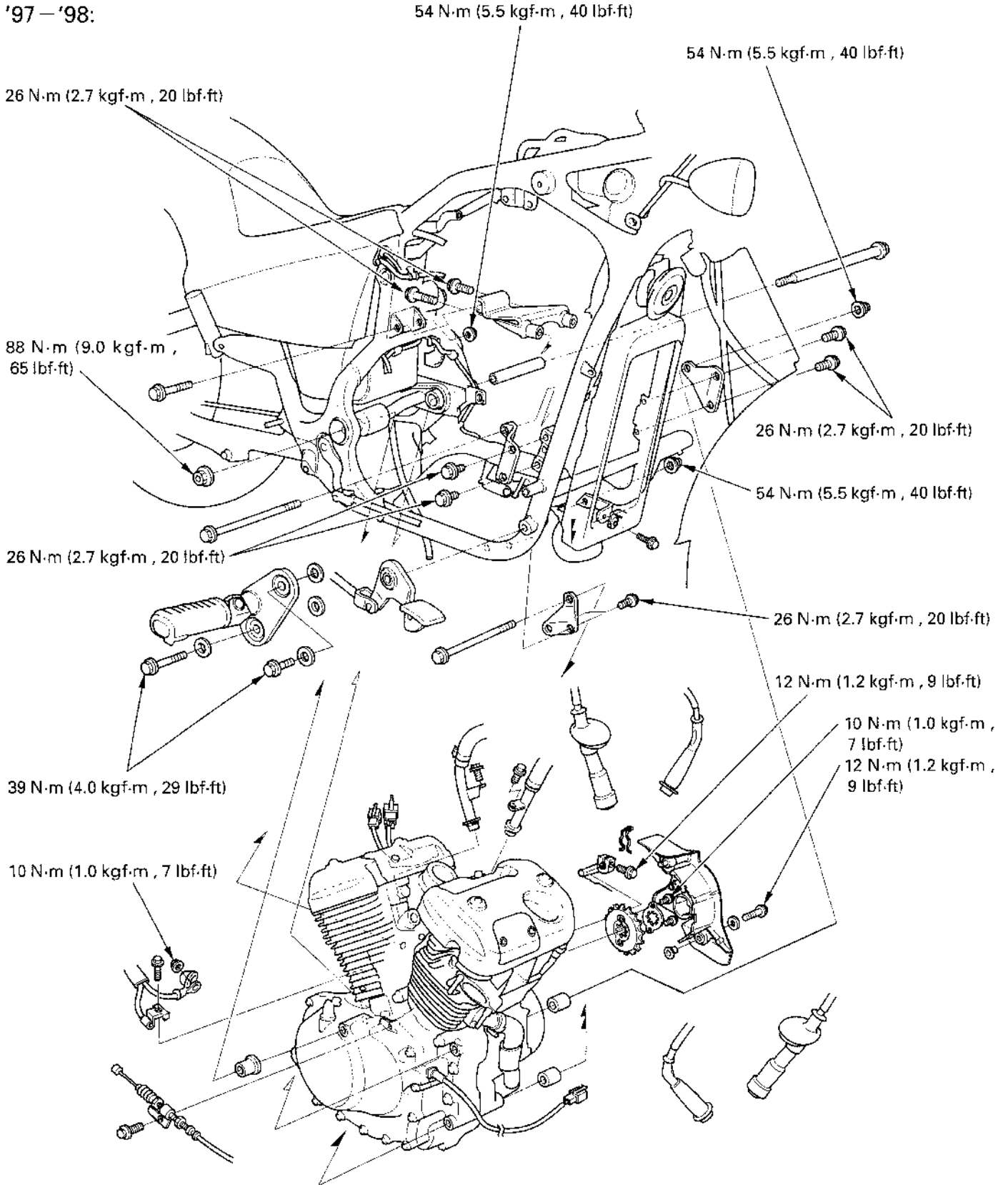

# 7. ENGINE REMOVAL/INSTALLATION

SERVICE INFORMATION	7-3	ENGINE INSTALLATION	7-9
DRIVE SPROCKET REMOVAL	7-4	DRIVE SPROCKET INSTALLATION	7-14
ENGINE REMOVAL	7-5		

After '98:

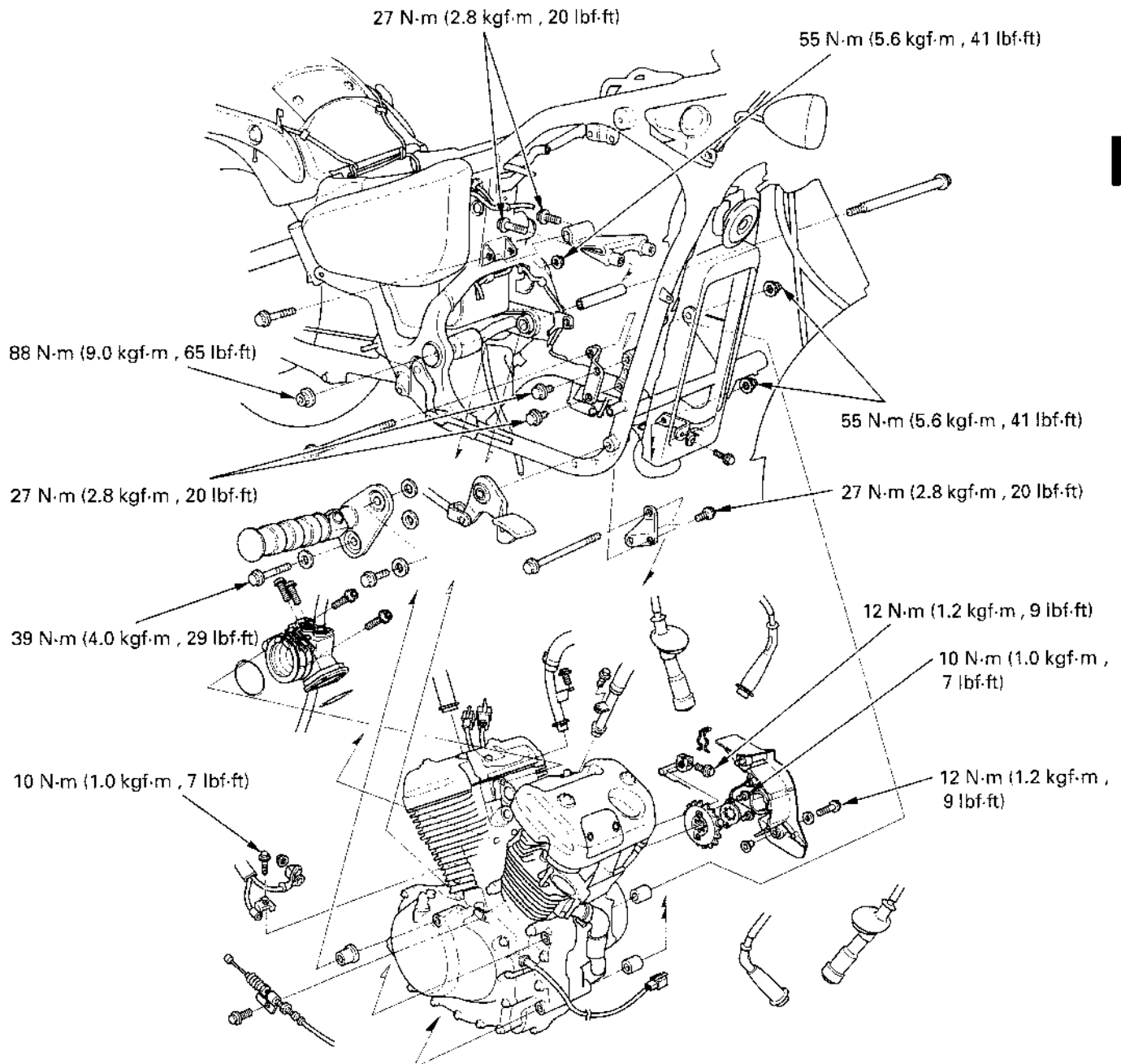

## ENGINE REMOVAL/INSTALLATION

---

### SERVICE INFORMATION

#### GENERAL

- A floor jack or other adjustable support is required to support and maneuver the engine.

#### CAUTION:

---

*Do not support the engine using the oil filter.*

---

- When removing/installing the engine, cover the frame around the engine with tape beforehand for frame protection.
- The following components can be serviced with the engine installed in the frame.
  - Alternator (Section 9)
  - Camshaft (Section 10)
  - Carburetor (Section 5)
  - Clutch/gearshift linkage (Section 8)
  - Front cylinder (Section 11)
  - Front cylinder head (Section 10)
  - Ignition pulse generator (Section 17)
  - Starter motor/starter clutch (Section 18)
- The following components require engine removal for service.
  - Cylinder/piston (Section 11)
  - Crankshaft (Section 12)
  - Oil pump (Section 4)
  - Rear cylinder (Section 11)
  - Rear cylinder head (Section 10)
  - Shift fork, shift drum and gearshift spindle (Section 12)
  - Transmission (Section 12)
  - Water pump body (Section 6)
- After engine installation, adjust the following.
  - Clutch cable (page 3-28)
  - Drive chain (page 3-20)
  - Throttle cable (page 3-4)

#### SPECIFICATION

ITEM		SPECIFICATIONS	
Engine dry weight	VT600C	'97	61.0 kg (134.5 lbs)
		After '98	62.0 kg (136.7 lbs)
	VT600CD		64.0 kg (141.1 lbs)
Engine oil capacity			2.8 ℓ (3.0 US qt , 2.5 imp qt)
Coolant capacity			1.6 ℓ (1.7 US qt , 1.4 imp qt)

**TORQUE VALUES**

Left rear cover bolt		12 N·m (1.2 kgf·m , 9 lbf·ft)
Drive sprocket setting plate bolt		10 N·m (1.0 kgf·m , 7 lbf·ft)
Clutch cable holder bolt		12 N·m (1.2 kgf·m , 9 lbf·ft)
Gearshift pedal pinch bolt		12 N·m (1.2 kgf·m , 9 lbf·ft)
Footpeg bracket bolt		39 N·m (4.0 kgf·m , 29 lbf·ft)
Swingarm pivot nut		88 N·m (9.0 kgf·m , 65 lbf·ft)
Front engine mounting bolt (upper)	'97-'98:	54 N·m (5.5 kgf·m , 40 lbf·ft)
	After '98:	55 N·m (5.6 kgf·m , 41 lbf·ft)
	(lower) '97-'98:	54 N·m (5.5 kgf·m , 40 lbf·ft)
	After '98:	55 N·m (5.6 kgf·m , 41 lbf·ft)
Rear engine mounting bolt	'97-'98:	54 N·m (5.5 kgf·m , 40 lbf·ft)
	After '98:	55 N·m (5.6 kgf·m , 41 lbf·ft)
Engine bracket bolt (front)	'97-'98:	26 N·m (2.7 kgf·m , 20 lbf·ft)
	After '98:	27 N·m (2.8 kgf·m , 20 lbf·ft)
	(rear) '97-'98:	26 N·m (2.7 kgf·m , 20 lbf·ft)
	After '98:	27 N·m (2.8 kgf·m , 20 lbf·ft)

**DRIVE SPROCKET REMOVAL**

Loosen the rear axle nut.  
Loosen both lock nuts and turn both adjusting bolts as necessary.  
Push the rear wheel forward fully, creating maximum drive chain slack.

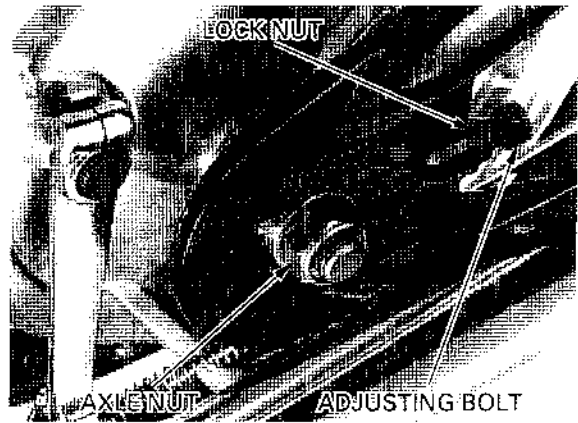

Remove the bolt, clip, washer and left rear cover.

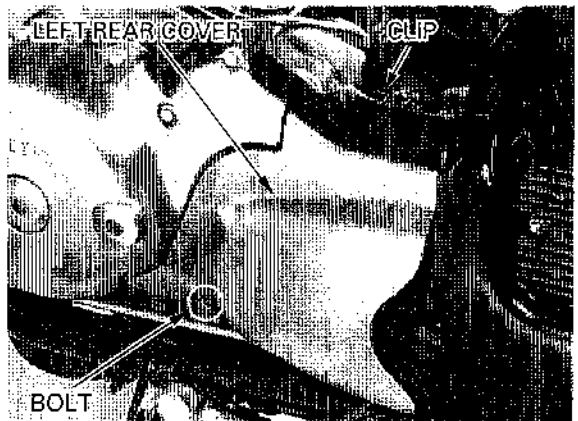

Remove the drive sprocket setting plate bolts.

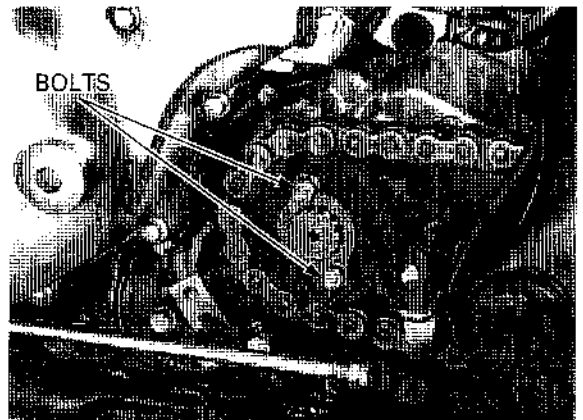

Align the drive sprocket setting plate teeth and countershaft teeth, then remove the drive sprocket setting plate.

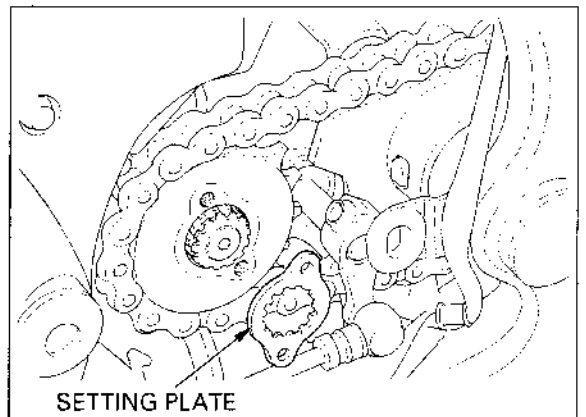

Remove the drive sprocket.

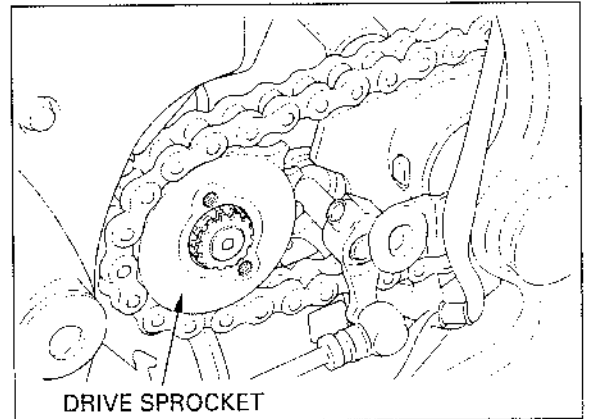

## ENGINE REMOVAL

### CAUTION:

*Do not support the engine using the oil filter.*

### NOTE:

- Support the motorcycle safety stand or a hoist.
- Turn the ignition switch OFF and disconnect the battery ground (–) cable (page 16-5).
- A floor jack or adjustable support is required to support and maneuver the engine. The jack height must be continually adjusted to relieve stress for ease of bolt removal.

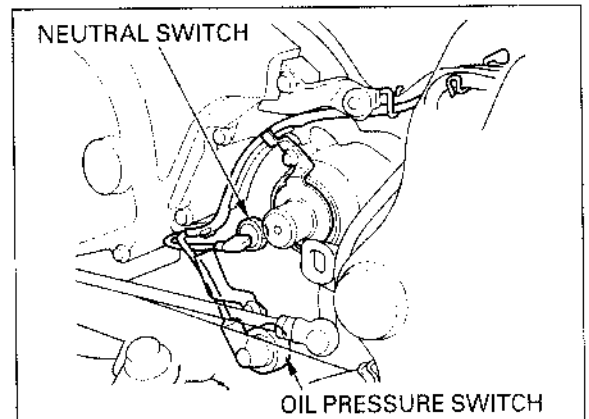

Drain the engine oil (page 3-14) and the radiator coolant (page 6-6).

Disconnect the battery negative cable from the battery terminal.

Remove the following:

- Fuel tank (page 2-4)
- Air cleaner housing (page 5-4)
- Air cleaner chamber (page 5-7)
- Carburetor (page 5-10)
- Exhaust pipe/muffler (page 2-14)
- Drive sprocket (page 7-4)

Disconnect the oil pressure and neutral switch wires from the switch terminals and free the switch wire harness from the engine and frame.

## ENGINE REMOVAL/INSTALLATION

---

Remove the nuts and disconnect the starter motor cable and ground cable from the starter motor.

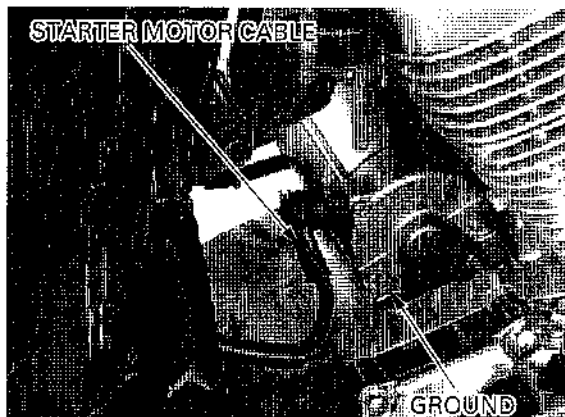

Remove the clutch cable holder bolt and disconnect the clutch cable from the clutch lifter arm.

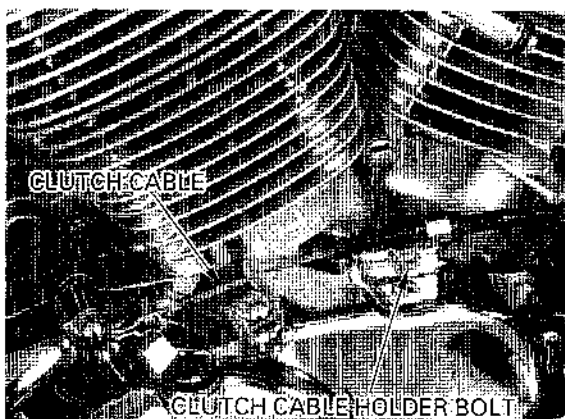

Remove the right footpeg bracket bolts.  
Remove the right footpeg and rear brake pedal.

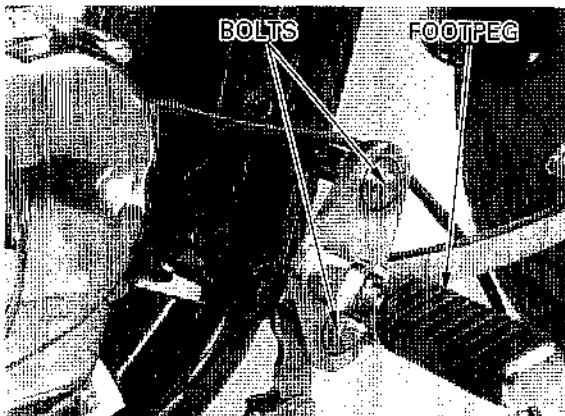

Disconnect the ignition pulse generator wire 4P (White) connector and free the wire harness from the engine and frame.

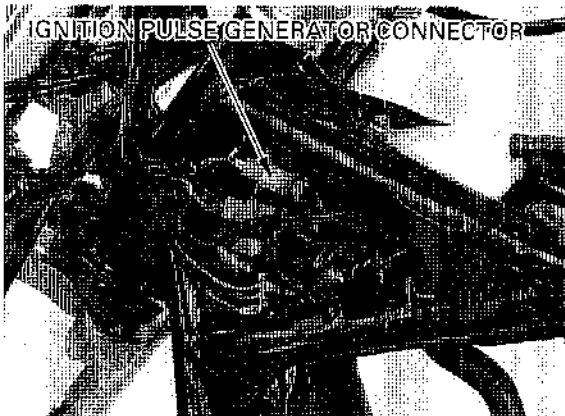



Disconnect the alternator wire 3P (White) connector and free the wire harness from the engine and frame.



Loosen the radiator hose band screw and remove the lower radiator hose (radiator-to-water pump).

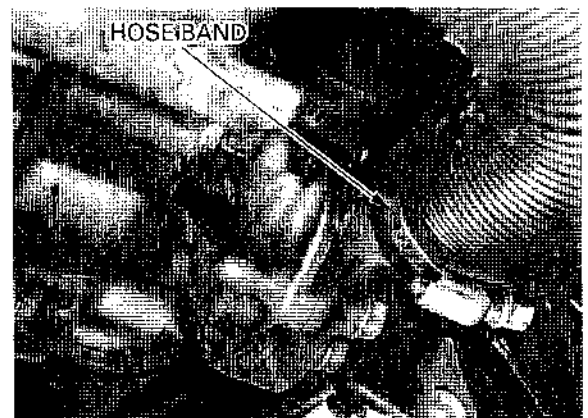

Remove the radiator mounting bolt.

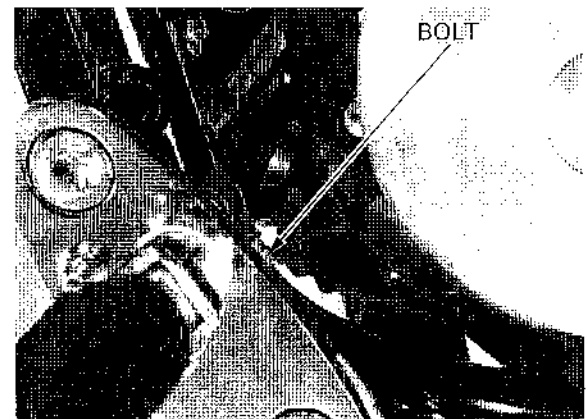

'97-'98: Disconnect the water hoses (thermostat housing-to-cylinder heads) from the cylinder heads (page 10-5).

Place a floor jack or other adjustable support under the engine.

**CAUTION:**

*Do not support the engine using the oil filter. This may break the oil filter mount resulting in crankcase replacement.*

**NOTE:**

The jack height must be continually adjusted to relieve stress for ease of bolt removal.

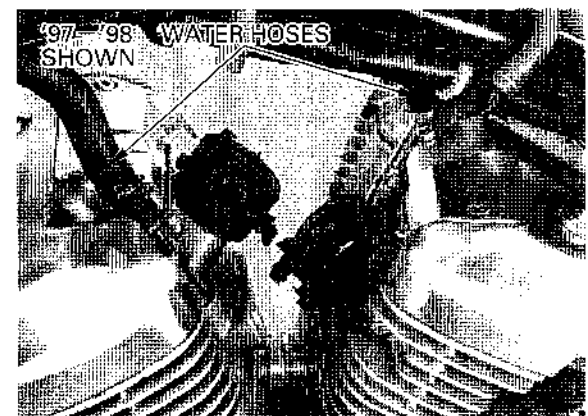

## ENGINE REMOVAL/INSTALLATION

*After '98:* Remove the water tube from the rear cylinder.  
Remove the bolts and the inlet manifold.

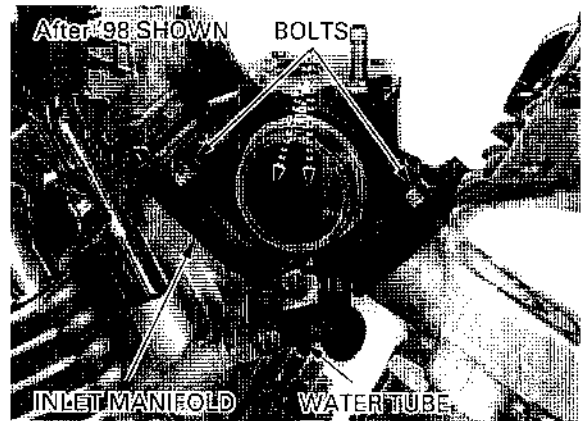

Unclamp the hose bands and disconnect the water hoses.

Disconnect the engine breather tube.

Place a floor jack or other adjustable support under the engine.

### CAUTION:

*Do not support the engine using the oil filter. This may break the oil filter mount resulting in crankcase replacement.*

### NOTE:

The jack height must be continually adjusted to relieve stress for ease of bolt removal.

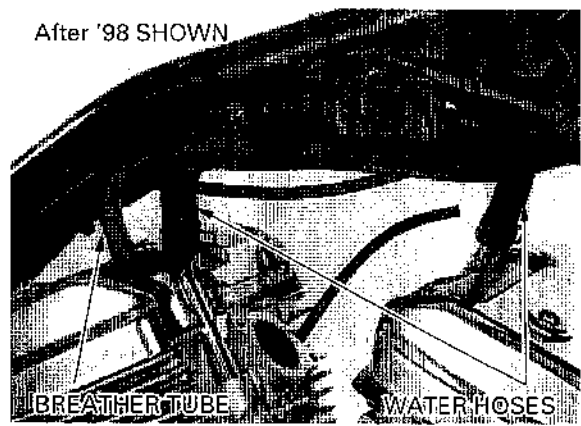

Remove the front upper engine mounting bolt/nut (10 mm) and collar.

Remove the front upper engine bracket bolts (8 mm) and bracket.

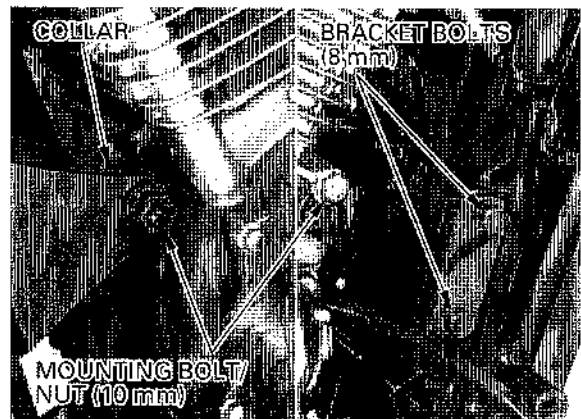

Remove the front lower engine mounting bolt/nut (10 mm).

Remove the front lower engine bracket bolts (8 mm) and bracket.

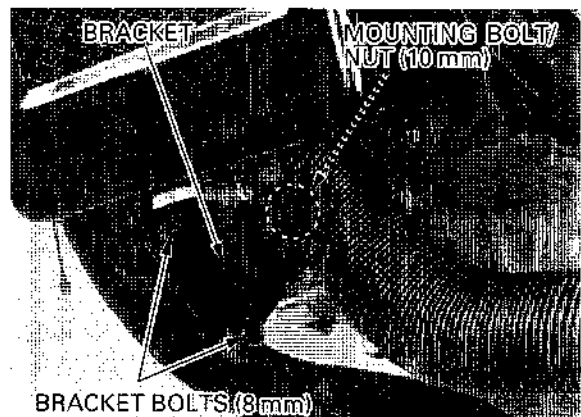

Remove the rear engine mounting bolt/nut (10 mm).  
Remove the rear engine bracket bolts (8 mm) and bracket.



Remove the swingarm pivot bolt caps.  
Remove the swingarm pivot bolt, nut and collars.

**CAUTION:**

*During engine removal, hold the engine securely and be careful not to damage the frame, engine and radiator fins.*

Remove the engine from the right side of the frame.

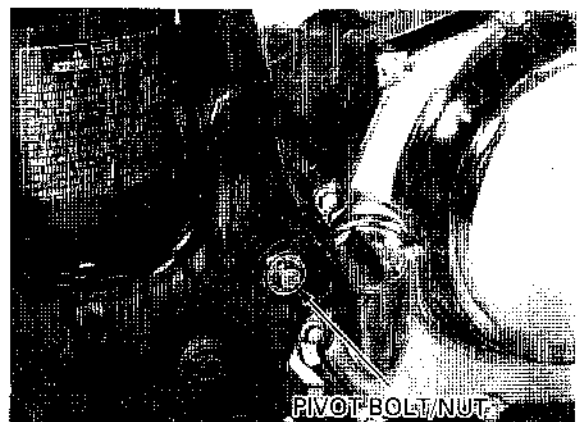

## ENGINE INSTALLATION

**CAUTION:**

*Carefully align the mounting points with the jack to prevent damage to engine, frame, wires and cables.*

**NOTE:**

- Loosely install all the engine mounting bolts and nuts, then tighten the bolts and nuts to the specified torque.
- At engine installation, temporarily install the drive chain to the gearshift spindle.
- Be sure to install the mounting collars and swingarm dust seals in their correct positions.

Use a floor jack or other adjustable support to carefully maneuver the engine in to place.  
Carefully align the bolt holes in the frame and engine.

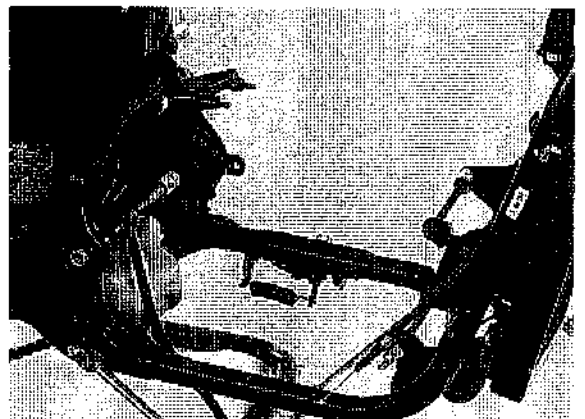

## ENGINE REMOVAL/INSTALLATION

Install the swingarm pivot collars, bolt and nut.

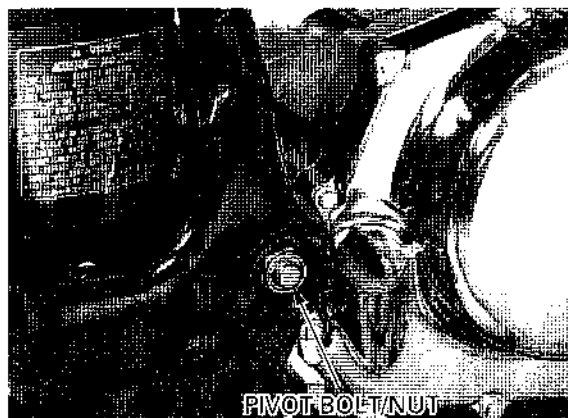

Install the rear engine bracket and bracket bolts (8 mm).

Install the rear engine mounting bolt/nut (10 mm).

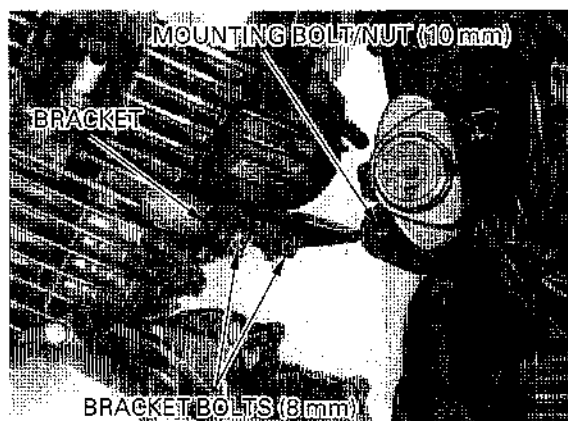

Install the front lower engine bracket and bracket bolts (8 mm).

Install the front lower engine mounting bolt/nut (10 mm).

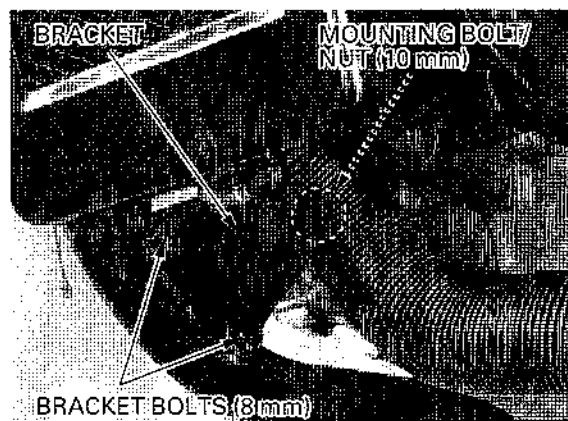

Install the front upper engine bracket and bracket bolts (8 mm).

Install the collar and front upper engine mounting bolt/nut (10 mm).

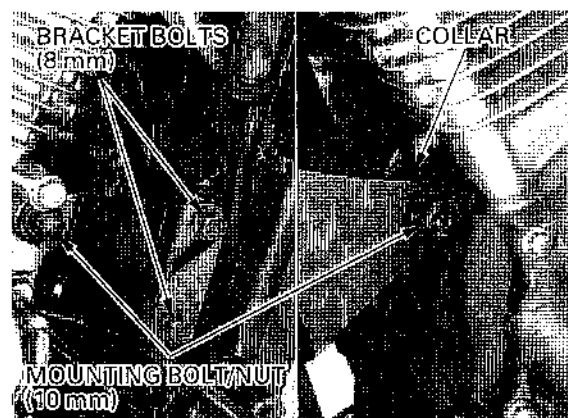

Tighten the engine bracket and mounting bolt/nut to the specified torque.

### TORQUE:

#### Engine bracket bolt (upper/lower)

'97-'98: 26 N·m (2.7 kgf·m, 20 lbf·ft)

After '98: 27 N·m (2.8 kgf·m, 20 lbf·ft)

#### Front engine mounting bolt (upper/lower)

'97-'98: 54 N·m (5.5 kgf·m, 40 lbf·ft)

After '98: 55 N·m (5.6 kgf·m, 41 lbf·ft)

#### Rear engine mounting bolt

'97-'98: 54 N·m (5.5 kgf·m, 40 lbf·ft)

After '98: 55 N·m (5.6 kgf·m, 41 lbf·ft)

## ENGINE REMOVAL/INSTALLATION

Tighten the swingarm pivot nut to the specified torque.

**TORQUE:** 88 N·m (9.0 kgf·m , 65 lbf·ft)

Install the swingarm pivot bolt caps.

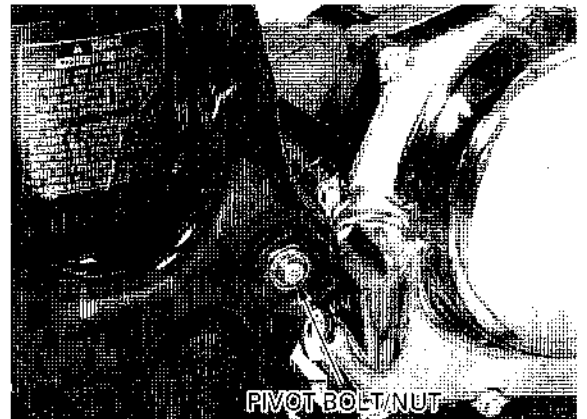

'97 - '98: Connect the water hoses (thermostat housing-to-cylinder heads) to the cylinder heads.

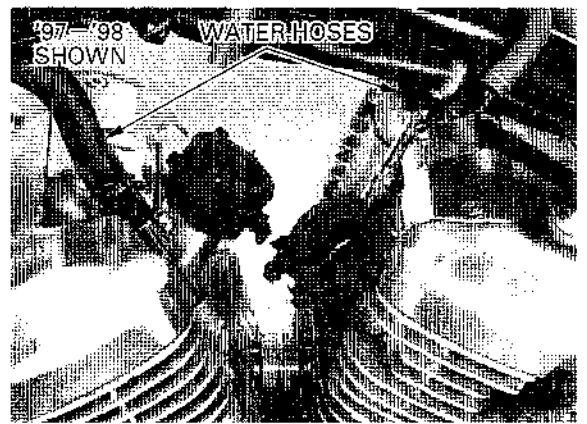

After '98: Connect the water hoses (thermostat housing-to-cylinder heads) to the cylinder heads and clamp the hose bands.  
Connect the engine breather tube.

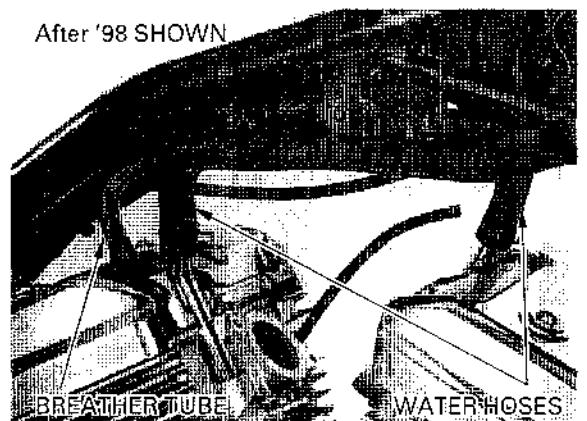

Apply engine oil to the new O-rings, then install to the inlet manifold.

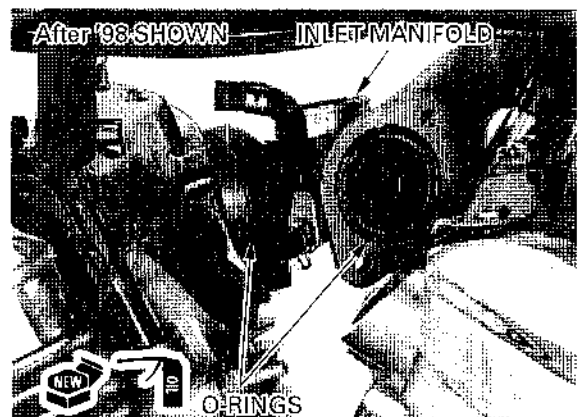

## ENGINE REMOVAL/INSTALLATION

Install the inlet manifold and tighten the bolts.  
Connect the water tube to the rear cylinder.

Install the following:

- Carburetor (page 5-26)
- Fuel auto valve (page 5-35)

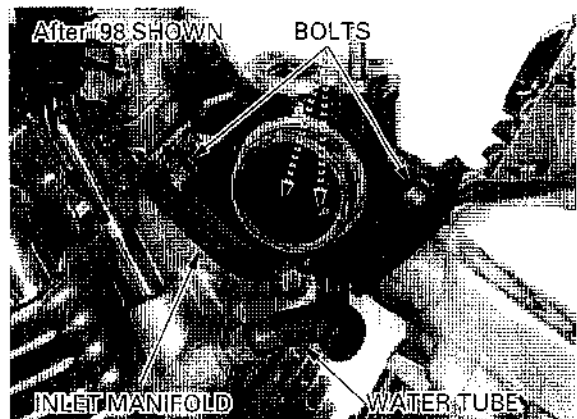

Install and tighten the radiator mount bolt to the specified torque.

**TORQUE:** 9 N·m (0.9 kgf·m , 6.5 lbf·ft)

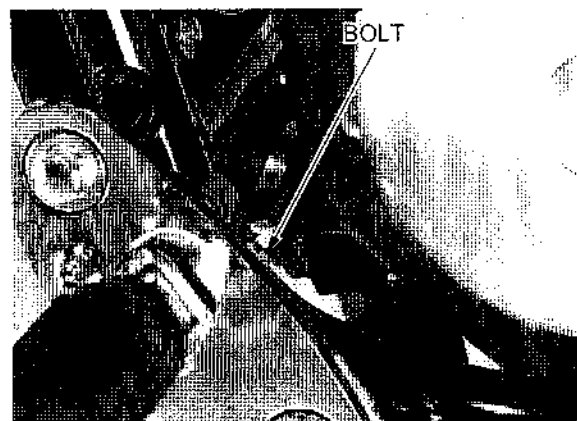

Connect the lower radiator hose (radiator-to-water pump) to the water pump.  
Tighten the band screw to the specified torque.

**TORQUE:** 7 N·m (0.7 kgf·m , 5.1 lbf·ft)



Route the alternator wire harness properly (refer to section 1).

Connect the alternator wire 3P (White) connector.



Route the ignition pulse generator wire harness properly (refer to section 2).  
Connect the ignition pulse generator wire 2P (White) connector.

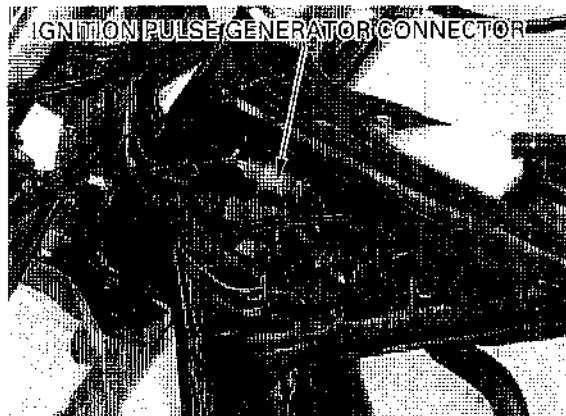

Install the rear brake pedal and right footpeg.  
Install and tighten the bracket bolt to the specified torque.

**TORQUE:** 39 N·m (4.0 kgf·m , 29 lbf·ft)

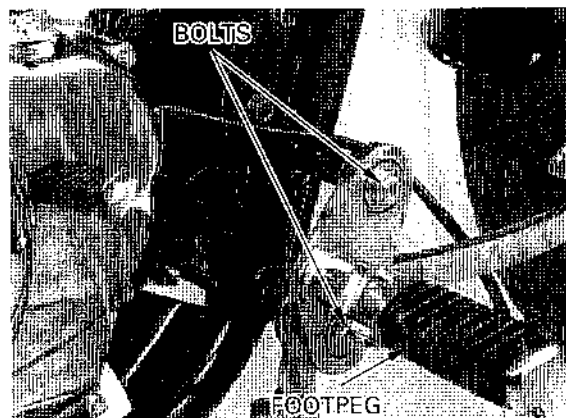

Connect the clutch cable to the clutch lifter arm.  
Install the clutch cable holder and bolt.  
Tighten the holder bolt to the specified torque.

**TORQUE:** 12 N·m (1.2 kgf·m , 9 lbf·ft)

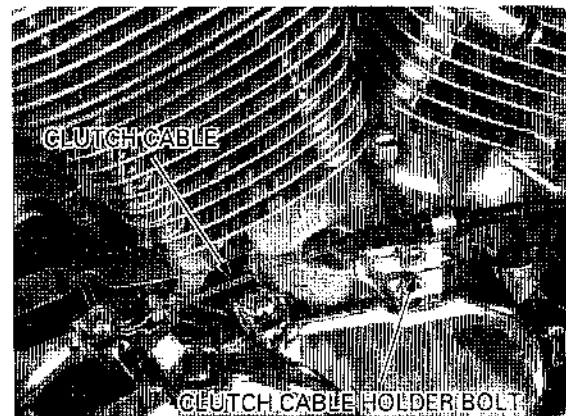

Connect the starter motor cable and ground cable to the starter motor.  
Install and tighten the cable nut to the specified torque.

**TORQUE:** 10 N·m (1.0 kgf·m , 7 lbf·ft)

Route the neutral switch and oil pressure switch wire harness properly (refer to section 2).  
Connect the wire terminals.  
Install and tighten the oil pressure switch terminal screw to the specified torque.

**TORQUE:** 2 N·m (0.23 kgf·m , 1.7 lbf·ft)

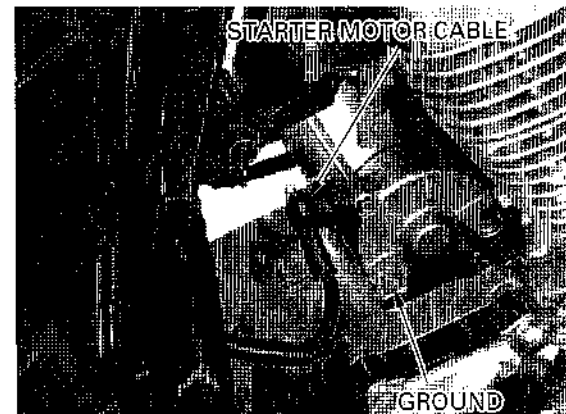

## ENGINE REMOVAL/INSTALLATION

Install the following:

- Drive sprocket (page 7-14)
- Gearshift arm (page 8-16)
- Exhaust pipe/muffler (page 2-15)
- Carburetor (page 5-26)
- Air cleaner chamber (page 5-7)
- Air cleaner housing (page 5-5)
- Fuel tank (page 2-7)

Fill the engine oil (page 3-14).

Fill and bleed the cooling system (page 6-6).

Connect the battery negative cable to the battery terminal.

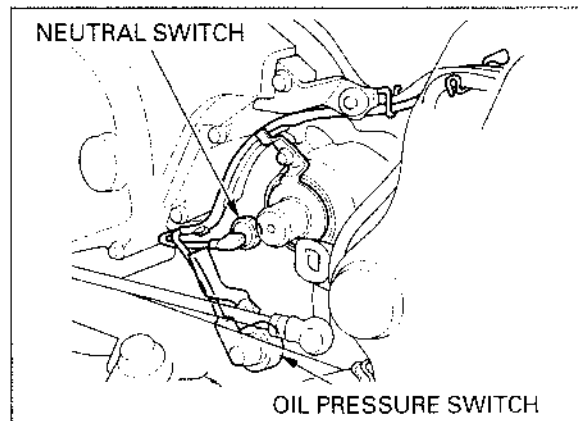

## DRIVE SPROCKET INSTALLATION

Install the drive chain to the drive sprocket.

Install the drive sprocket to the countershaft with its marking side facing out.

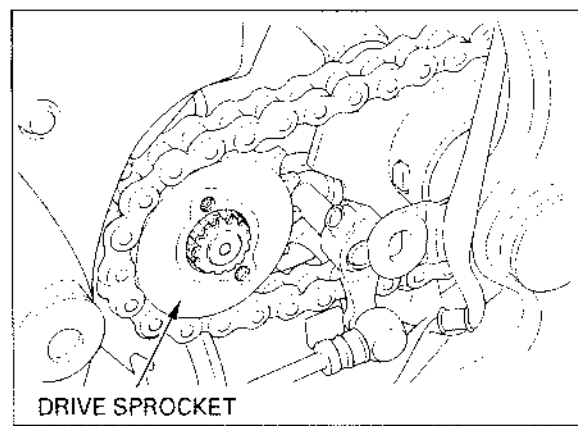

Install the drive sprocket setting plate onto the countershaft and align the bolt holes on the plate with the holes of the sprocket.

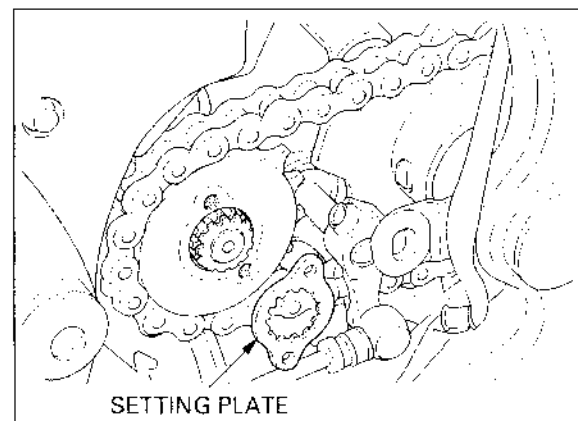

Install and tighten the drive sprocket setting plate bolts to the specified torque.

**TORQUE:** 10 N·m (1.0 kgf·m , 7 lbf·ft)

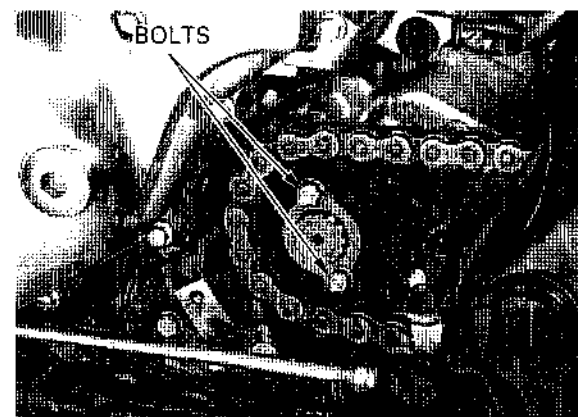



Install the left rear cover, washer and clip to the securely.

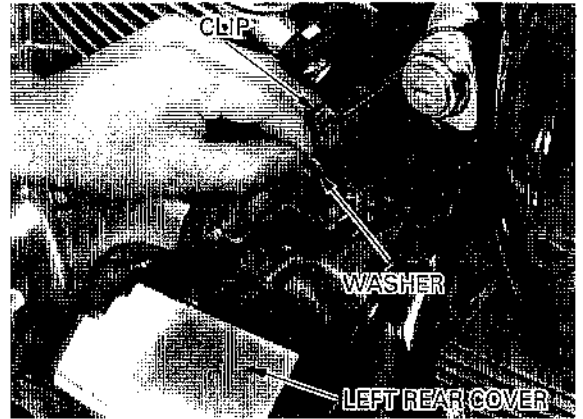

Install and tighten the left rear cover bolt to the specified torque.

**TORQUE:** 12 N·m (1.2 kgf·m , 9 lbf·ft)

Adjust the drive chain slack (page 3-20).

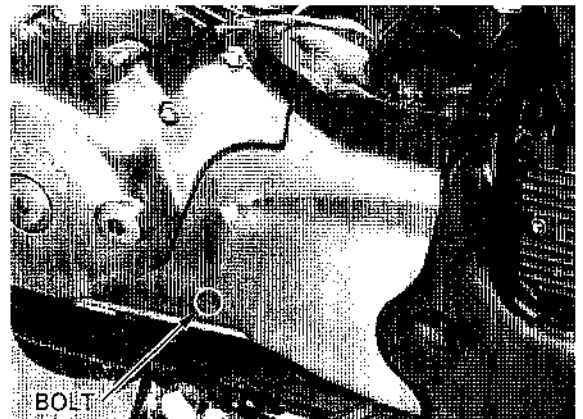

# CLUTCH/GEARSHIFT LINKAGE

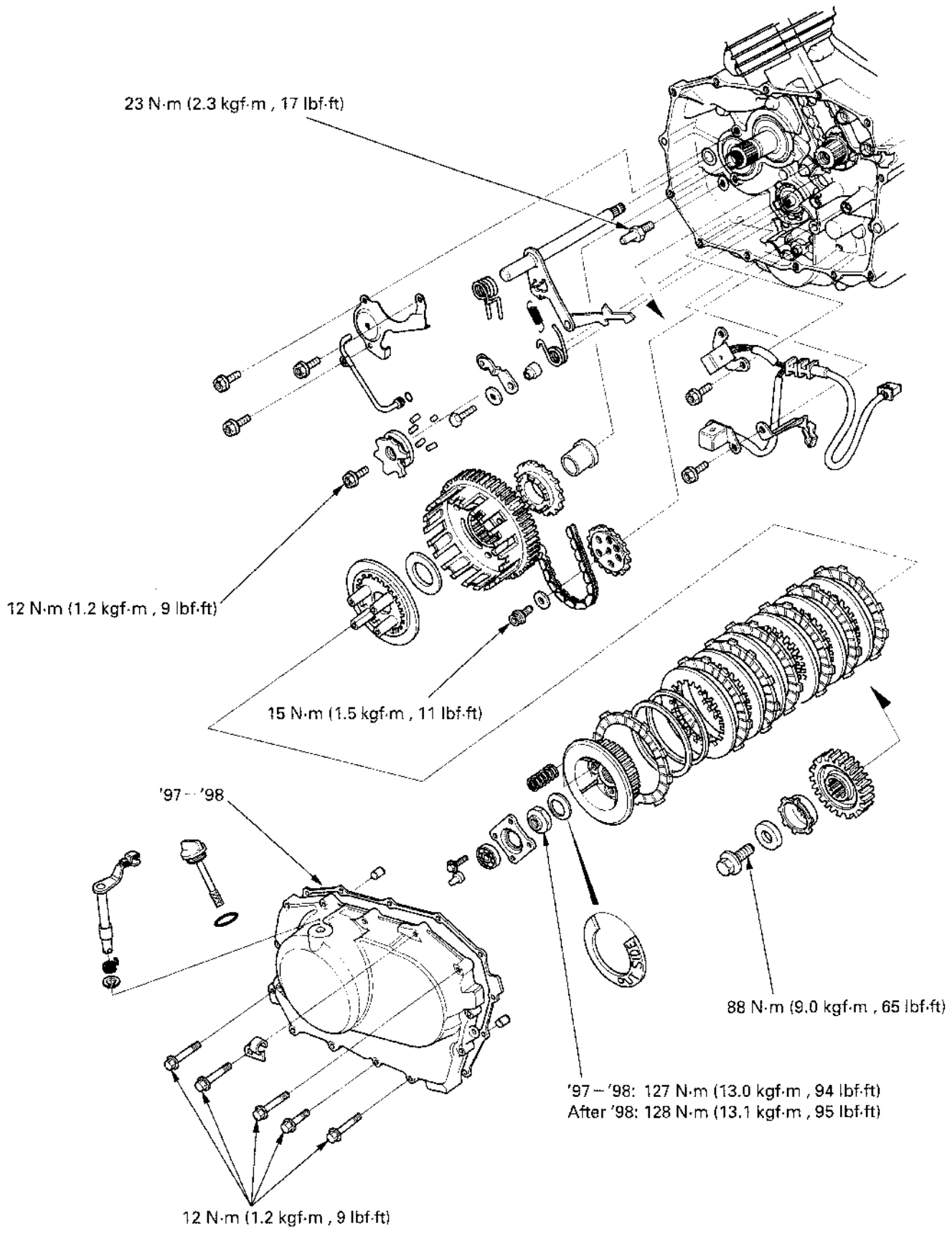

# 8. CLUTCH/GEARSHIFT LINKAGE

<b>SERVICE INFORMATION</b>	8-1	<b>PRIMARY DRIVE GEAR</b>	8-9
<b>TROUBLESHOOTING</b>	8-2	<b>GEARSHIFT LINKAGE</b>	8-12
<b>RIGHT CRANKCASE COVER REMOVAL</b>	8-3	<b>CLUTCH INSTALLATION</b>	8-16
<b>CLUTCH REMOVAL</b>	8-5	<b>RIGHT CRANKCASE COVER INSTALLATION</b>	8-20

## SERVICE INFORMATION

### GENERAL

- The clutch and gearshift linkage maintenance can be done with the engine in the frame.
- Engine oil viscosity and level, and the use of oil additives have an effect on clutch disengagement. Oil additives of kind are not recommended. When the clutch does not disengage or the motorcycle creeps with the clutch disengaged, inspect the engine oil viscosity and level before servicing the clutch system.
- Clean off any gasket material from the right crankcase cover surface.
- Be careful not to damage the crankcase cover mating surface when servicing.
- When removing or servicing the clutch and gearshift linkage, use care not to allow dust or dirt to enter the engine.
- The crankcase must be separated when the transmission requires service (Section 12).
- Refer to section 17 for ignition pulse generator inspection.

8

### SPECIFICATIONS

UNIT: mm (in)

ITEM		STANDARD	SERVICE LIMIT
Clutch lever free play		10 – 20 (3/8 – 3/4)	—
Clutch spring free length		43.2 (1.70)	41.6 (1.64)
Clutch disc thickness	A	2.92 – 3.08 (0.115 – 0.121)	2.6 (0.10)
	B	2.92 – 3.08 (0.115 – 0.121)	2.6 (0.10)
Clutch plate warpage		—	0.30 (0.012)
Clutch outer guide	I.D.	21.991 – 22.016 (0.8658 – 0.8668)	22.09 (0.870)
	O.D.	31.959 – 31.975 (1.2582 – 1.2589)	31.98 (1.259)
Clutch outer I.D.		32.000 – 32.025 (1.2598 – 1.2608)	32.10 (1.264)
Oil pump drive sprocket I.D.		32.000 – 32.025 (1.2598 – 1.2608)	32.10 (1.264)
Mainshaft O.D. at clutch outer guide		21.967 – 21.980 (0.8648 – 0.8654)	21.92 (0.863)

### TORQUE VALUES

Right crankcase cover bolt	12 N·m (1.2 kgf·m , 9 lbf·ft)	
Clutch cable holder bolt	12 N·m (1.2 kgf·m , 9 lbf·ft)	
Clutch lifter plate bolt	12 N·m (1.2 kgf·m , 9 lbf·ft)	
Clutch center lock nut	'97 – '98: 127 N·m (13.0 kgf·m , 94 lbf·ft)	Stake
	After '98: 128 N·m (13.1 kgf·m , 95 lbf·ft)	
Primary drive gear bolt	88 N·m (9.0 kgf·m , 65 lbf·ft)	UBS bolt
		Apply oil to the threads and seating surface
Gearshift cam plate bolt	12 N·m (1.2 kgf·m , 9 lbf·ft)	Apply a locking agent to the threads
Gearshift pedal pinch bolt	12 N·m (1.2 kgf·m , 9 lbf·ft)	
Gearshift return spring pin	23 N·m (2.3 kgf·m , 17 lbf·ft)	
Oil pump driven sprocket bolt	15 N·m (1.5 kgf·m , 11 lbf·ft)	Apply a locking agent to the threads

## CLUTCH/GEARSHIFT LINKAGE

---

### TOOLS

Lock nut wrench, 17 × 27 mm  
Gear holder  
Clutch center holder

07716--0020300 or equivalent commercially available in U.S.A.  
07724--0010100  
07JMB--MN50301 or 07HGB--001010A or (U.S.A. only)  
07HGB--001010B and  
07HGB--001020A  
07HGB--001020B

### TROUBLESHOOTING

#### Clutch lever too hard

- Damaged, kinked or dirty clutch cable
- Faulty clutch lifter plate bearing
- Damaged clutch lifter mechanism
- Improperly routed clutch cable

#### Clutch will not disengage or motorcycle creeps with clutch disengaged

- Too much clutch lever free play
- Warped clutch plates
- Loose clutch center lock nut
- Engine oil too high, improper oil viscosity

#### Clutch slips

- Clutch lifter sticking
- Worn clutch discs
- Weak clutch springs
- No clutch lever free play

#### Hard to shift

- Improper clutch operation or incorrect clutch adjustment
- Bent or damaged shift forks (Section 12)
- Bent shift fork shaft (Section 12)
- Bent or damaged gearshift spindle
- Damaged shift drum cam grooves

#### Transmission jumps out of gear

- Worn gear dogs or slots
- Bent shift fork shaft (Section 12)
- Broken shift drum stopper arm
- Worn or bent shift forks (Section 12)
- Broken gearshift linkage return spring

## RIGHT CRANKCASE COVER REMOVAL

Drain the engine oil (page 3-14).  
Disconnect the clutch cable from the clutch lifter arm.

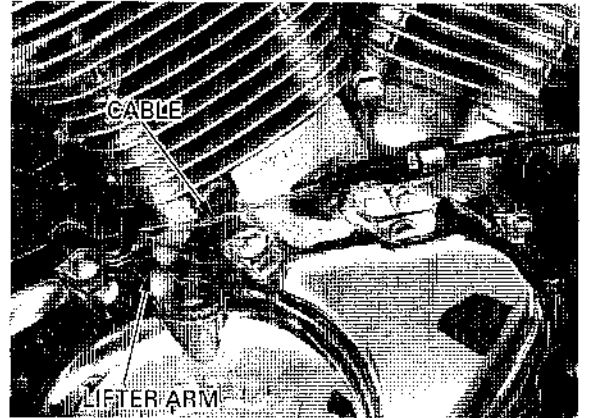

Remove the right crankcase bolts and cover.

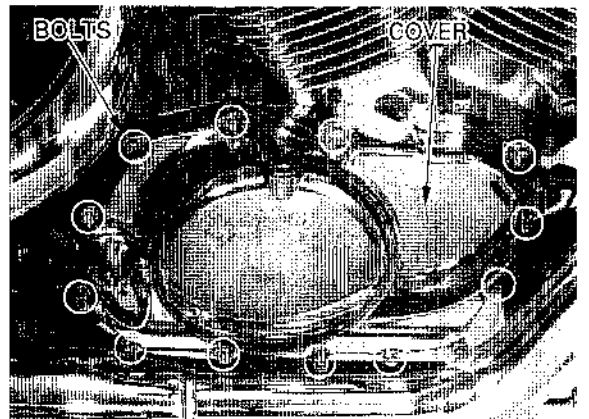

'97 '98: Remove the dowel pins and gasket.

**NOTE:**

After '98 models have sealant instead of a paper gasket.

*After '98: Be careful not to damage the mating surface.*

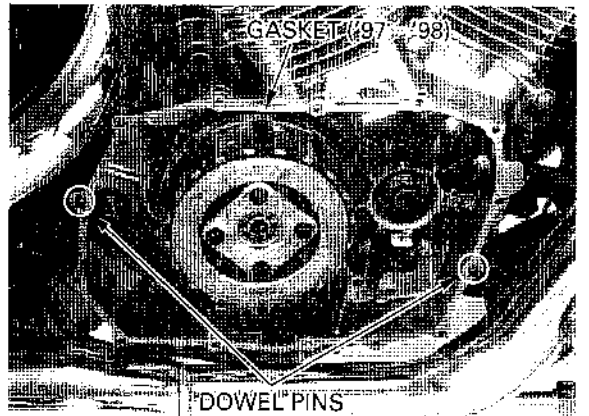

## DISASSEMBLY

Remove the clutch lifter piece.

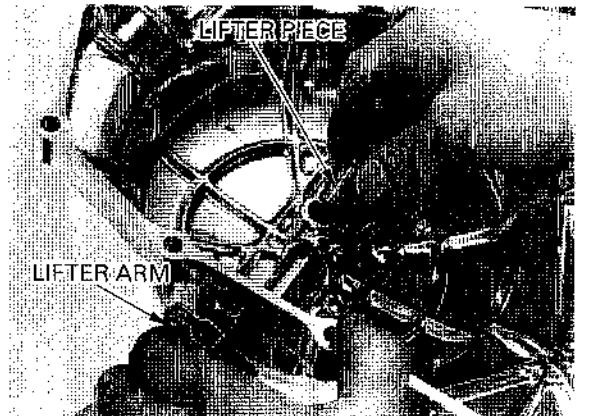

## CLUTCH/GEARSHIFT LINKAGE

Remove the snap ring and return spring from the right crankcase cover.

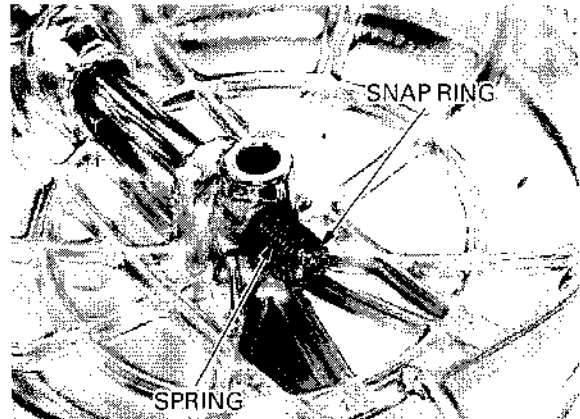

Remove the clutch lifter arm.

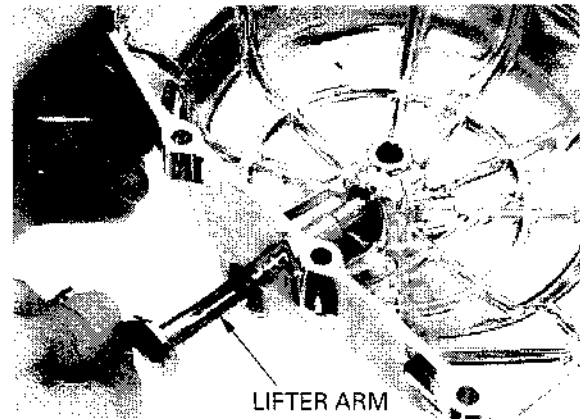

### INSPECTION

Check the dust seal fatigue or damage.  
Check the needle bearing for wear, damage or loose fit.  
Replace these parts if necessary.

#### NOTE:

If the dust seal replacement is required, press the dust seal to the case surface.

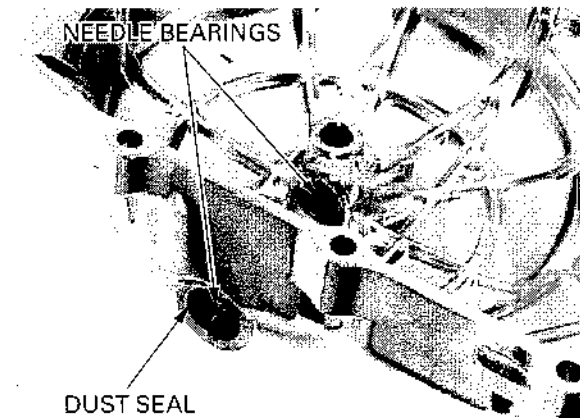

Check the clutch lifter arm for damage or bending.  
Check the spring for fatigue or damage.  
Replace these parts if necessary.

Apply grease to the clutch lifter arm sliding surface.  
Apply grease to the dust seal lips and needle bearing.

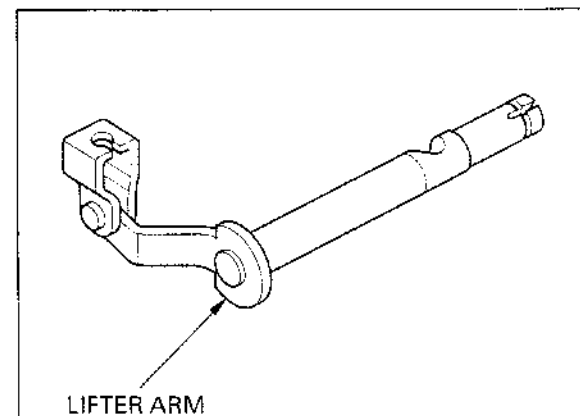

## CLUTCH REMOVAL

*If the oil pump driven sprocket will be removed, loosen the driven sprocket bolt with the clutch is still installed.*

Remove the right crankcase cover (page 8-3).

Loosen the clutch lifter plate bolts in a crisscross pattern in 2 or 3 steps.  
Remove the lifter plate/bearing and clutch springs.

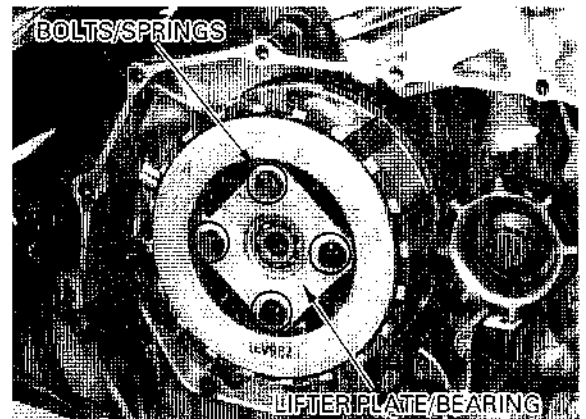

Unstake the clutch center lock nut.

**CAUTION:**

*Be careful not to damage the mainshaft threads.*

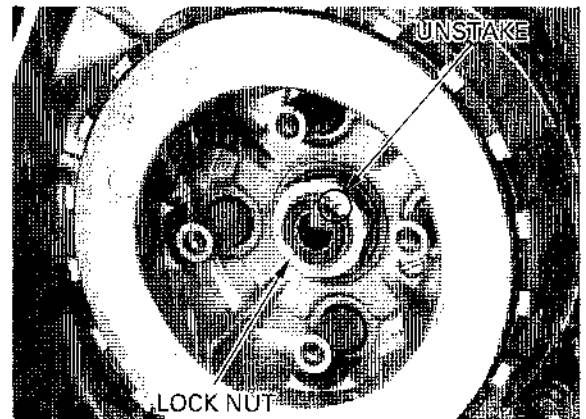

Hold the pressure plate with the clutch center holder and loosen the clutch center lock nut.

**TOOL:**

- |                             |  |
|-----------------------------|--|
| <b>Clutch center holder</b> | 07JMB-MN50301 or<br>07HGB-001010A or<br>07HGB-001010B and<br>07HGB-001020A<br>07HGB-001020B<br>(U.S.A. only) |
| <b>Lock nut wrench</b>      | 07716-0020300<br>Equivalent commercially<br>available in U.S.A.  |

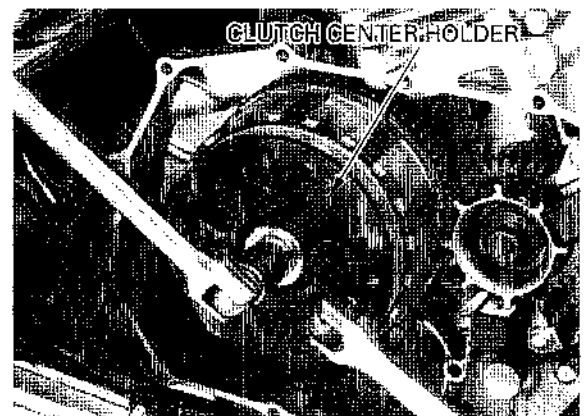

## CLUTCH/GEARSHIFT LINKAGE

---

Remove the clutch center lock nut and washer.

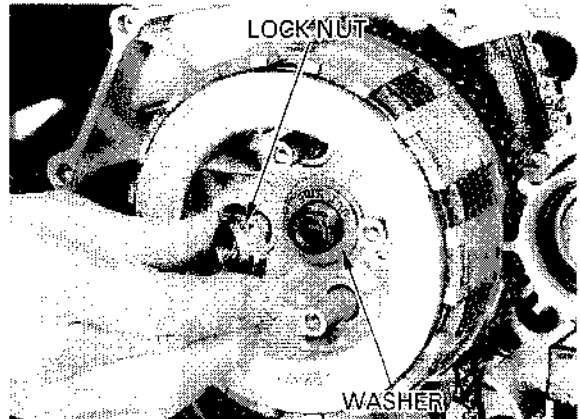

Remove the clutch center.  
Remove the judder spring, spring seat, clutch discs and clutch plates as a set.  
Remove the pressure plate.



Remove the washer and clutch outer.

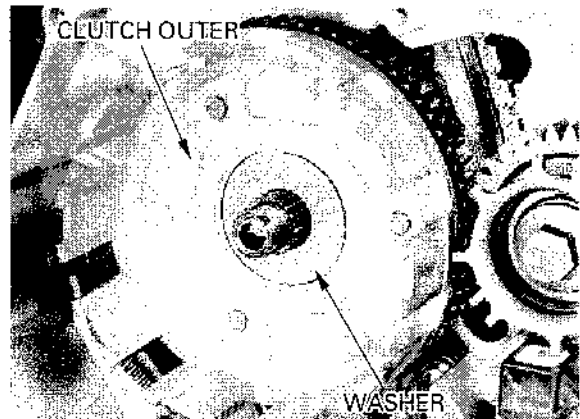

Remove the oil pump driven sprocket bolt and washer.

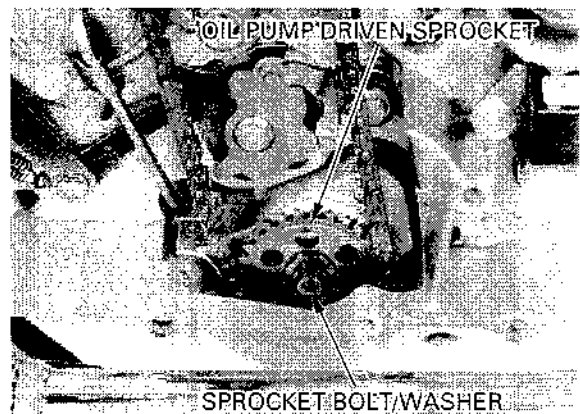



Remove the oil pump drive sprocket, driven sprocket and oil pump drive chain as a set.  
Remove the clutch outer guide.

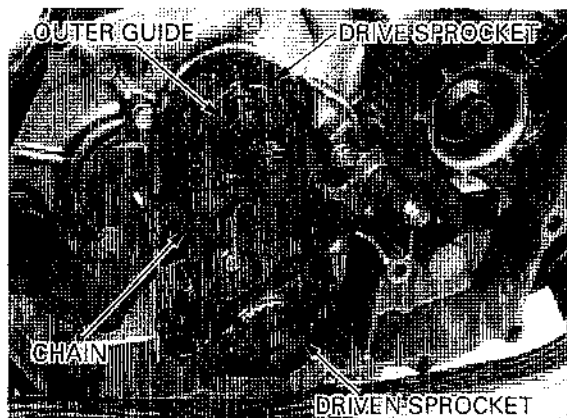

### INSPECTION

#### LIFTER PLATE BEARING

Check the lifter plate bearing for damage.  
Turn the bearing inner race with your finger. The bearing should turn smoothly and quietly without play.  
Also check that the bearing outer race fits in the plate.  
Replace the bearing if necessary.

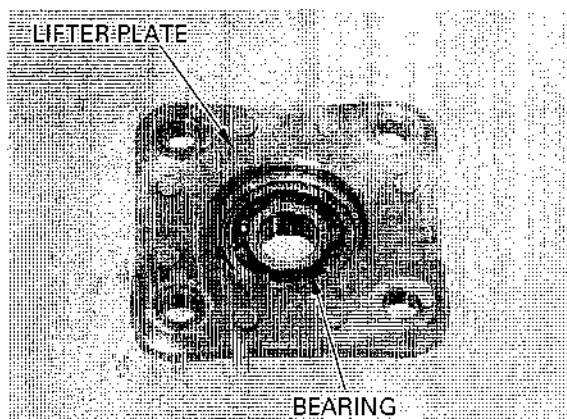

#### CLUTCH SPRING

*Replace the clutch springs as a set.*

Measure the clutch spring free length.

**SERVICE LIMIT:** 41.6 mm (1.64 in)

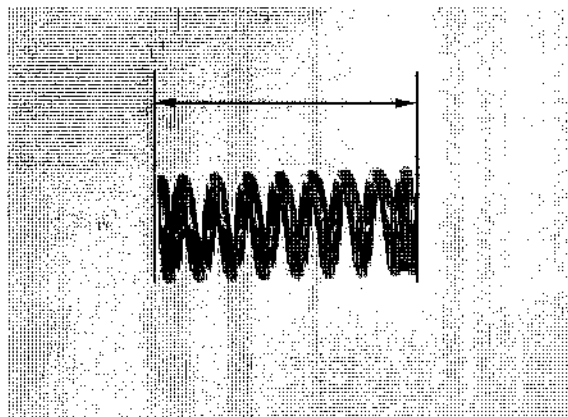

#### CLUTCH DISC

*Replace the discs and plates as a set.*

Check the clutch discs for signs of scoring or discoloration.

Measure the thickness of the discs.

#### SERVICE LIMITS:

**Disk A:** 2.6 mm (0.10 in)

**Disk B:** 2.6 mm (0.10 in)

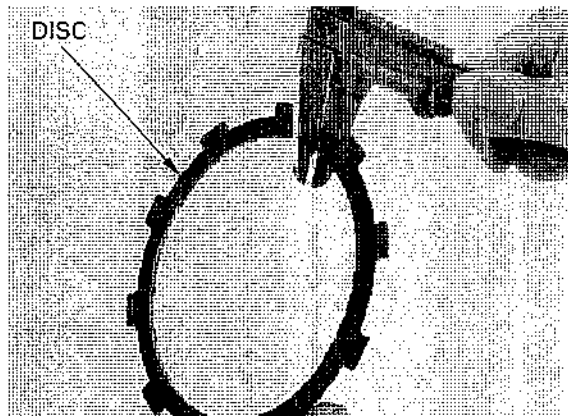

## CLUTCH/GEARSHIFT LINKAGE

---

### CLUTCH PLATE

*Replace the discs and plates as a set.*

Check the plate for excessive warpage or discoloration.  
Check the plate warpage on a surface plate using a feeler gauge.

**SERVICE LIMIT:** 0.30 mm (0.012 in)

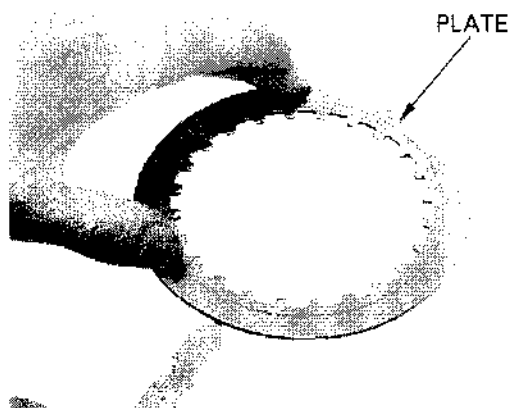

### CLUTCH CENTER

Check the clutch center for nicks, indentations or abnormal wear made by the clutch plates.

CLUTCH CENTER

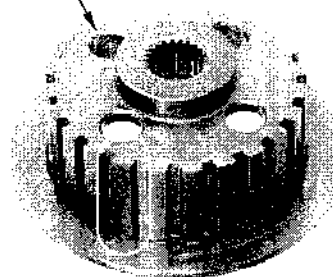

### CLUTCH OUTER

Check the slots in the clutch outer for nicks or indentations made by clutch discs.

Measure the I.D. of the clutch outer.

**SERVICE LIMIT:** 32.10 mm (1.264 in)

CLUTCH OUTER

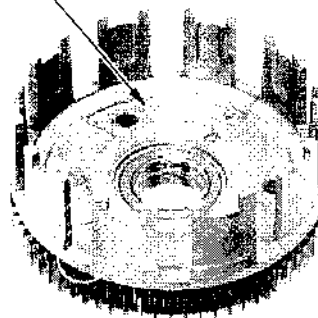

### CLUTCH OUTER GUIDE

Measure the clutch outer guide.

**SERVICE LIMITS:** O.D.: 31.98 mm (1.259 in)

I.D.: 22.09 mm (0.870 in)



### OIL PUMP DRIVE SPROCKET

Check the oil pump drive sprocket for damage.  
Measure the I.D. of the drive sprocket.

**SERVICE LIMIT:** 32.10 mm (1.264 in)

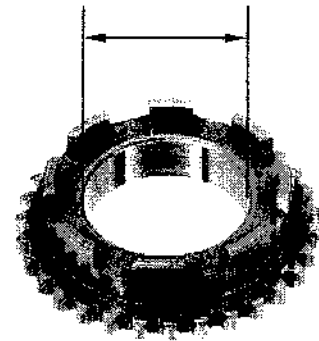

### MAINSHAFT

Measure the mainshaft O.D. at the clutch outer guide.

**SERVICE LIMIT:** 21.92 mm (0.863 in)

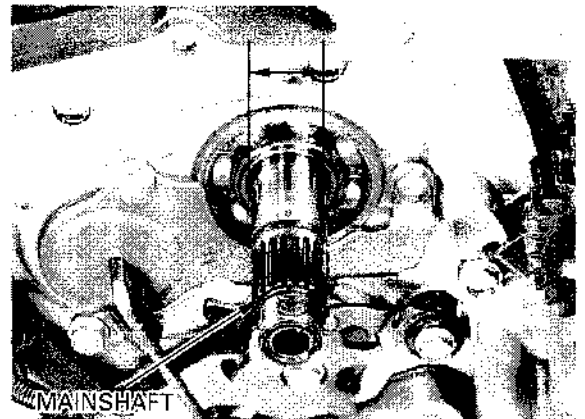

### JUDDER SPRING, SPRING SEAT

Check the spring seat and judder spring for distortion, wear or damage.

SPRING SEAT

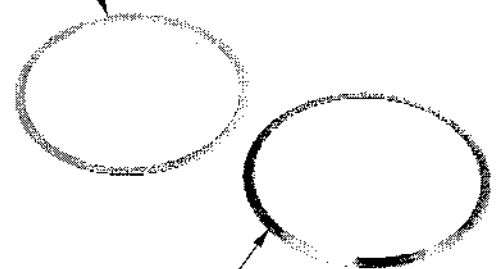

JUDDER SPRING

## PRIMARY DRIVE GEAR

### REMOVAL

Remove the clutch (page 8-5).

Remove the ignition pulse generator mounting bolts and ignition pulse generators.

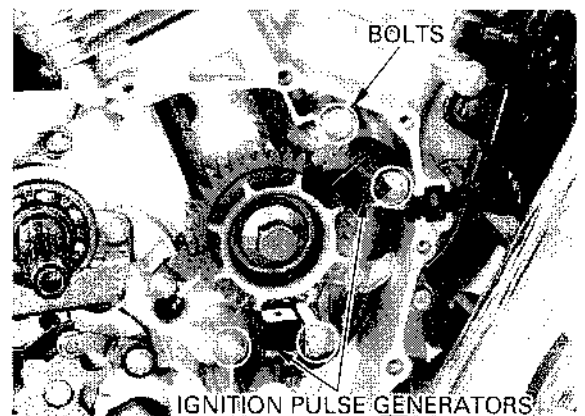

## CLUTCH/GEARSHIFT LINKAGE

Temporarily install the clutch outer onto the mainshaft.  
Hold the primary drive gear with the gear holder and remove the primary drive gear bolt.

**TOOL:**

**Gear holder**

07724-0010100

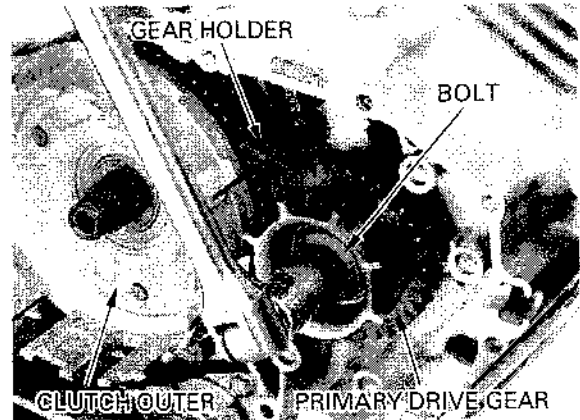

Remove the clutch outer and gear holder.  
Remove the ignition pulse generator rotor and primary drive gear.

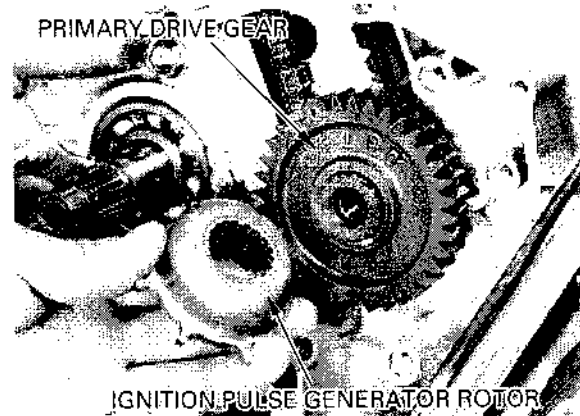

### INSPECTION

Check the serrated teeth of the primary drive gear for wear or damage.  
Check the serrated teeth of the sub gear for wear or damage.

PRIMARY DRIVE GEAR

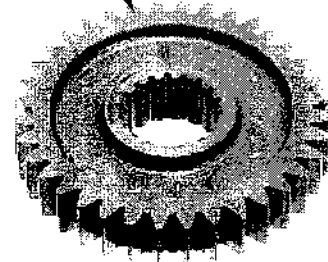

### INSTALLATION

*The primary drive gear will only go on in one position because of the extra wide aligning spline.*

Install the primary drive gear with the "OUT" mark facing out.

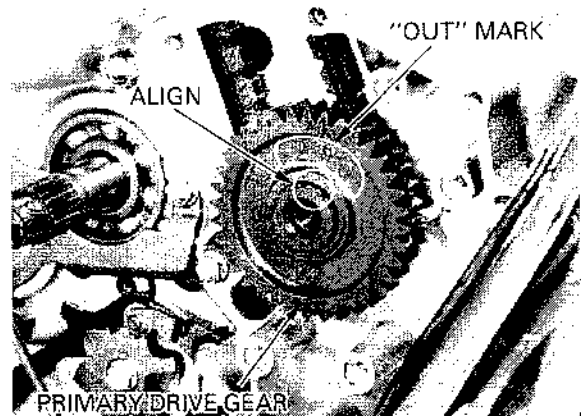

*The ignition pulse generator rotor will only go on in one position because of the extra wide aligning spline.*

Install the ignition pulse generator rotor.

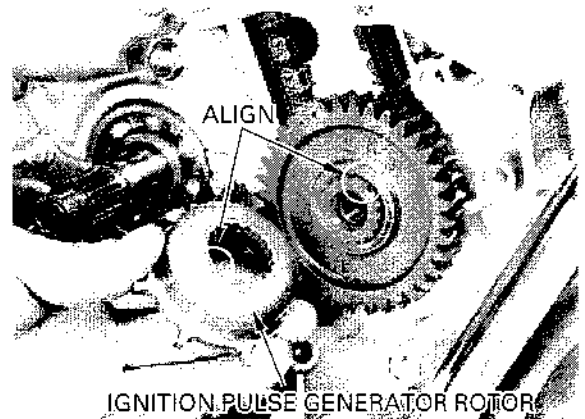

Apply engine oil to the primary drive gear bolt threads and seating surface.  
Install the washer and primary drive gear bolt.

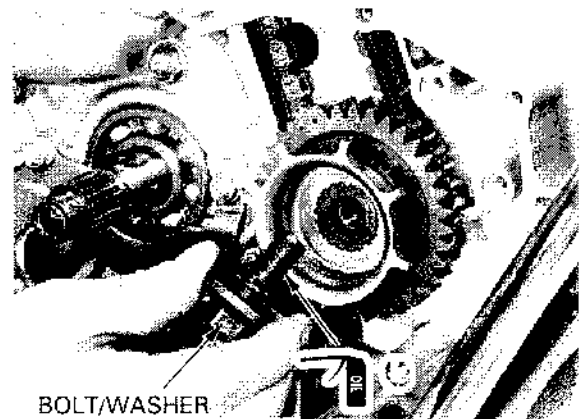

Temporarily install the clutch outer onto the mainshaft.  
Hold the primary drive gear with the gear holder.

**TOOL:**  
**Gear holder** 07724-0010100

Tighten the primary drive gear bolt to the specified torque.

**TORQUE:** 88 N·m (9.0 kgf·m , 65 lbf·ft)

Remove the gear holder, clutch outer and clutch outer guide.

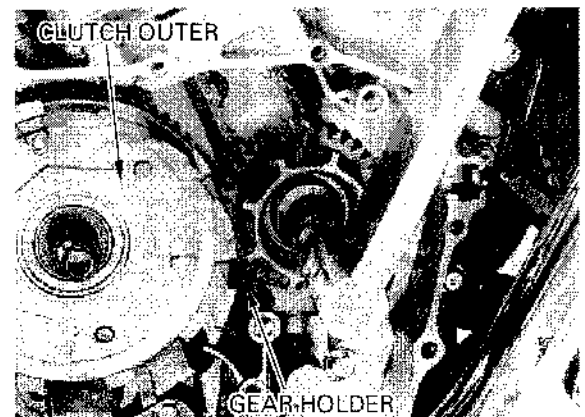

Apply a locking agent to the ignition pulse generator bolt threads.  
Install the ignition pulse generators and tighten the bolts to the specified torque.

**TORQUE:** 12 N·m (1.2 kgf·m , 9 lbf·ft)

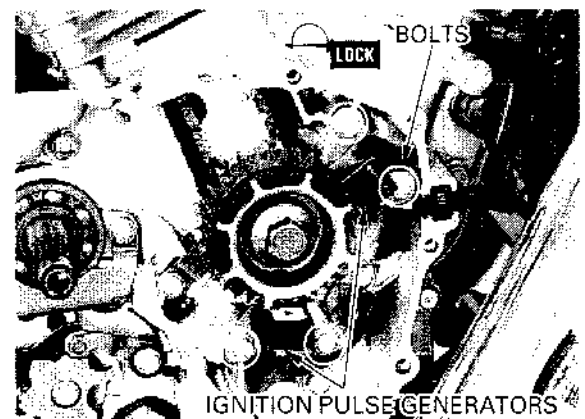

## CLUTCH/GEARSHIFT LINKAGE

Install the clutch (page 8-16).

### NOTE:

If the ignition pulse generator wire grommets were removed from the case groove, reinstall them securely.

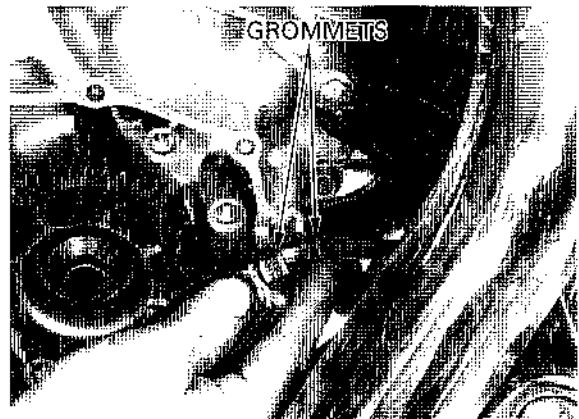

## GEARSHIFT LINKAGE

### REMOVAL

Remove the left rear cover (page 7-4).  
Remove the gearshift arm pinch bolt and gearshift arm from the gearshift spindle.

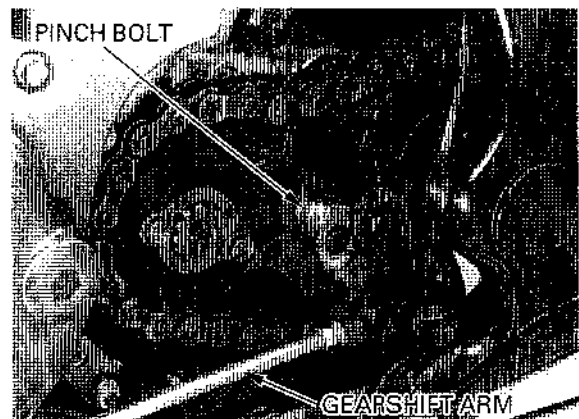

Remove the bolts and gearshift pedal/arm from the left footpeg.

Remove the following:

- Right crankcase cover (page 8-3)
- Clutch (page 8-5)
- Oil pump drive chain (page 8-6)

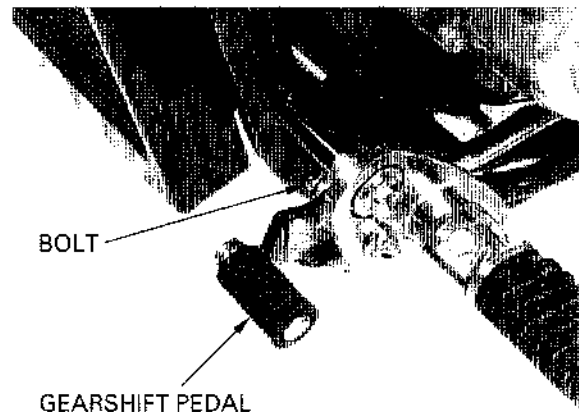

Remove the oil pipe stay mounting bolt and oil pipe mounting bolt.  
Pull the oil pipe out of the stay and oil pump.

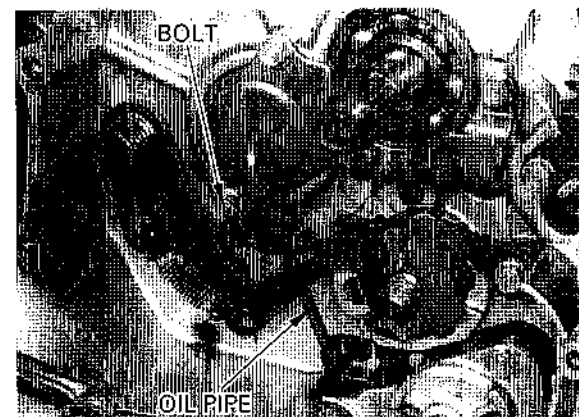

## CLUTCH/GEARSHIFT LINKAGE

Remove the O-ring from the oil pipe.

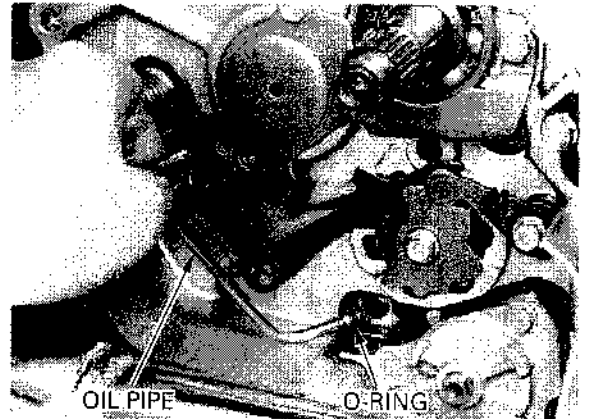

Remove the gearshift spindle from the crankcase while unhooking the shifter arm from the gearshift cam plate.

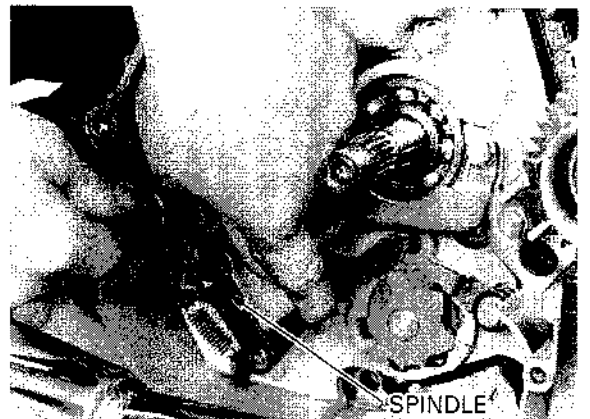

Remove the bolt, washer, gearshift drum stopper, collar and spring.

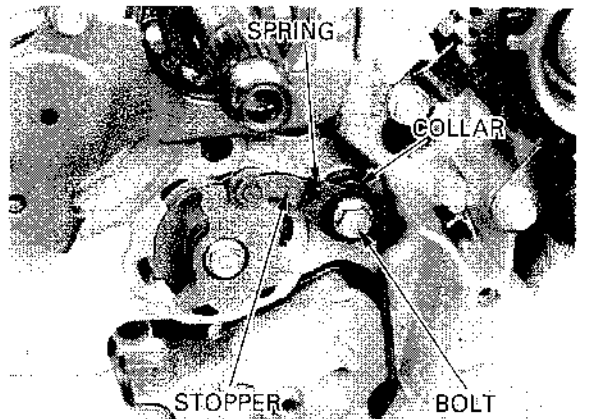

Remove the bolt and gearshift cam plate.

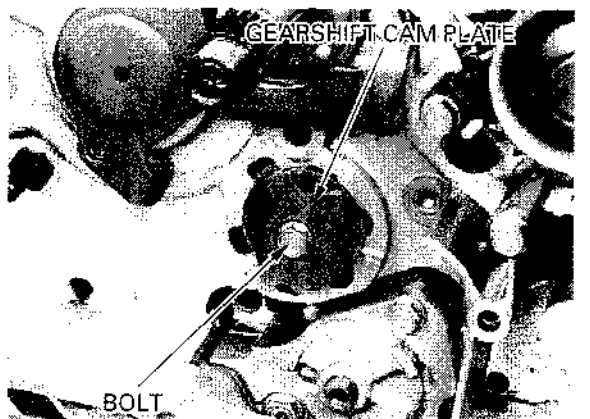

## CLUTCH/GEARSHIFT LINKAGE

### INSPECTION

Check the gearshift spindle for wear or damage.  
Check the return spring for fatigue or damage.

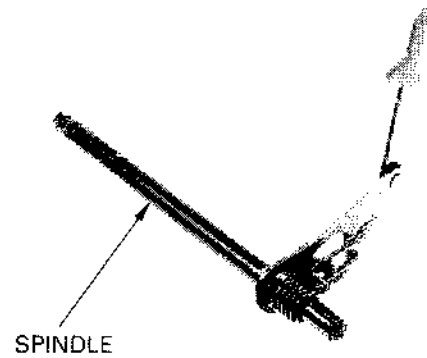

Inspect the gearshift pedal shaft for damage or loose lock nuts.

Replace the shaft if necessary.

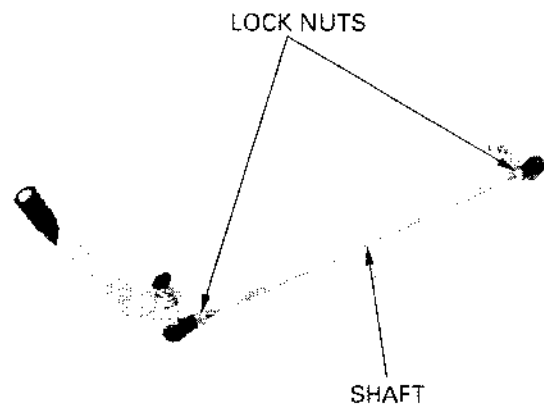

Inspect the dust seals and pivot collar for wear or damage.

Replace if necessary.

Apply grease to the dust seal lips and pivot collar.  
Install them into the pedal shaft.

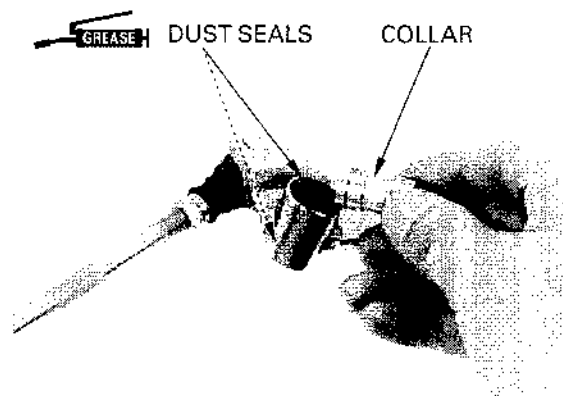

### INSTALLATION

Install the gearshift cam plate to the shift drum.

#### NOTE:

Install the gearshift cam plate aligning the hole on the cam plate with the dowel pin.

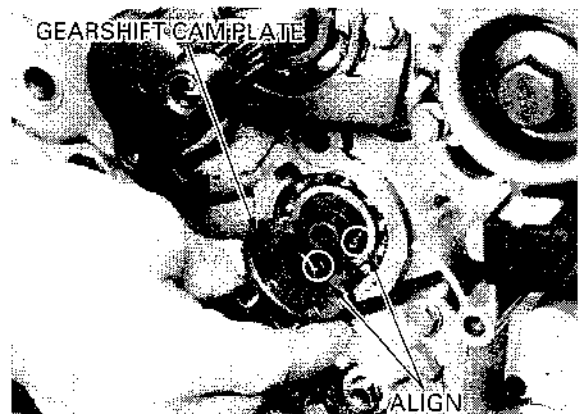



Clean and apply a locking agent to the gearshift cam plate bolt threads.

Install and tighten the bolt to the specified torque.

**TORQUE:** 12 N·m (1.2 kgf·m , 9 lbf·ft)

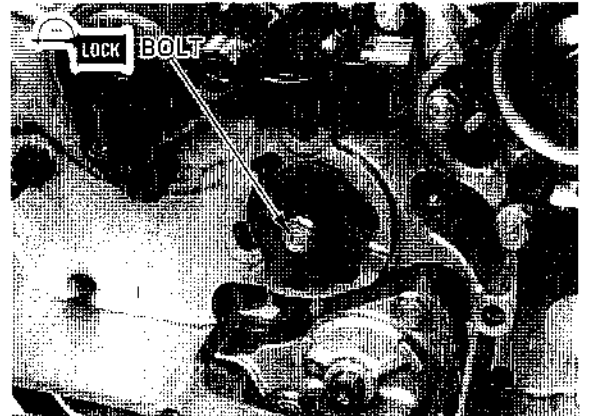

Install the collar, spring, gearshift drum stopper, washer and bolt as a set. Tighten the bolt securely.

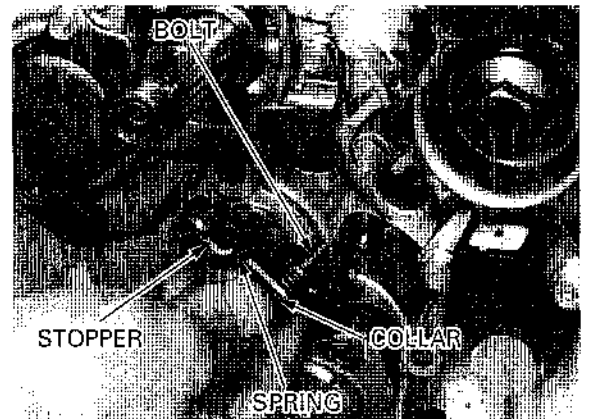

Install the gearshift spindle by aligning the return spring ends with the pin in the case.

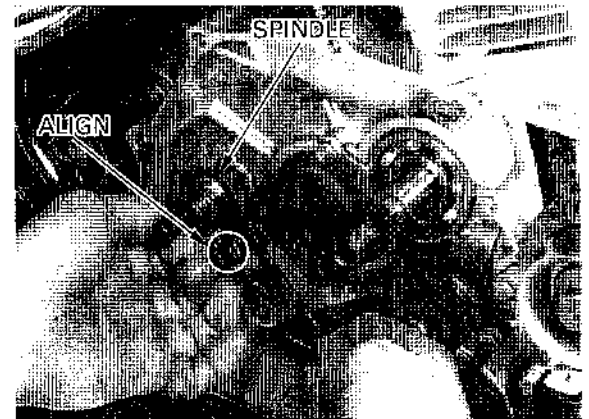

Apply oil to the new O-ring. Install the oil pipe with a new O-ring onto the oil pipe stay and oil pump.

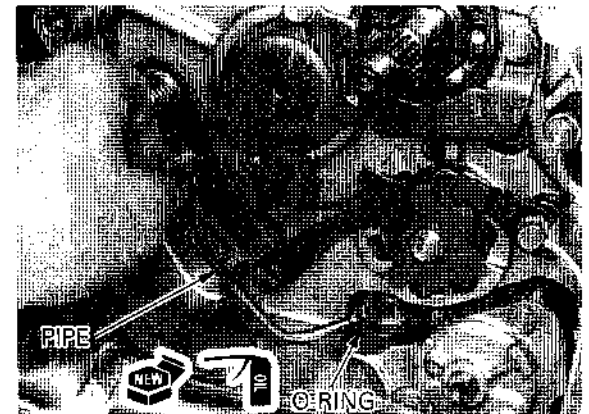

## CLUTCH/GEARSHIFT LINKAGE

Install and tighten the bolt securely.

Install the following:

- Oil pump drive chain/Clutch (see below)
- Right crankcase cover (page 8-20)

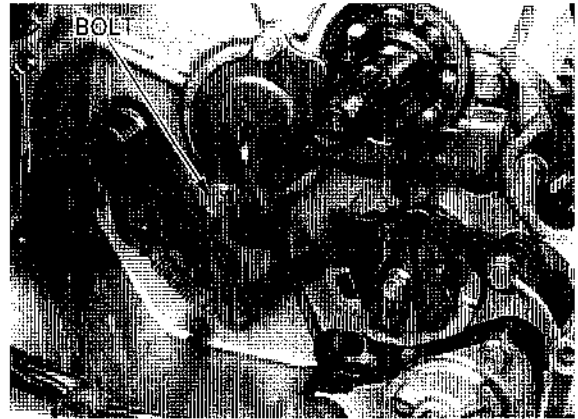

Install the gearshift pedal and gearshift pedal mounting bolt.

Tighten the mounting bolt securely.

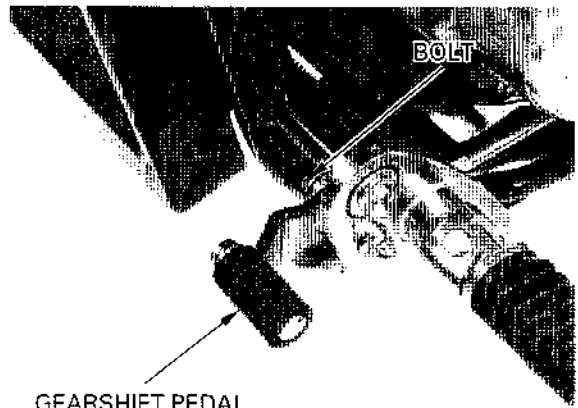

Install the gearshift arm to the gearshift spindle aligning the punch mark on the spindle with the punch mark of the gearshift arm.

Install and tighten the gearshift arm pinch bolt to the specified torque.

**TORQUE:** 12 N·m (1.2 kgf·m , 9 lbf·ft)

Install the left rear cover (page 7-15).

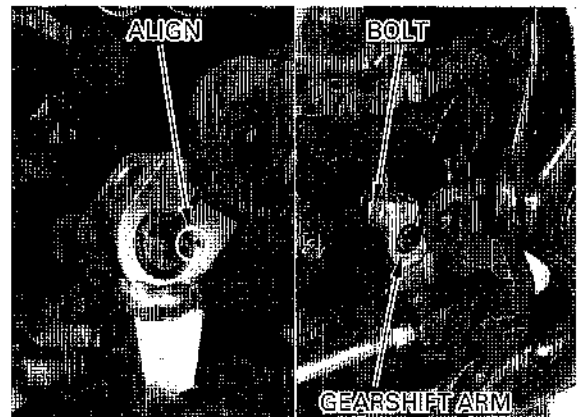

## CLUTCH INSTALLATION

**NOTE:**

If the oil pump driven sprocket is removed, tighten the driven sprocket bolt to the specified torque after clutch installation.

*Install the oil pump drive sprocket with its tabs side facing out.*

Apply molybdenum disulfide oil to the clutch outer guide outer surface.  
Install the clutch outer guide to the mainshaft.  
Install the oil pump drive sprocket to the clutch outer guide.

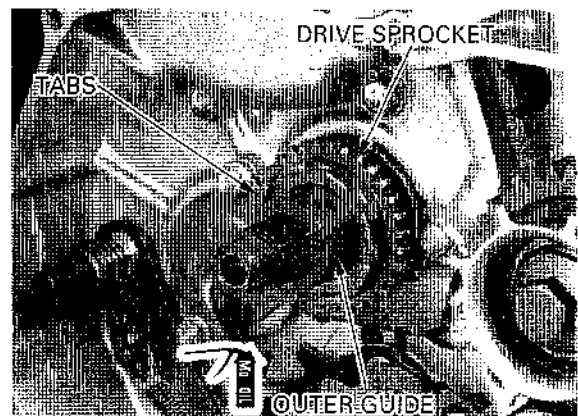

Install the oil pump drive chain to the oil pump drive and driven sprocket.  
Install the oil pump driven sprocket with the "IN" mark on the driven sprocket facing inside.  
Align the flat surfaces of the driven sprocket hole and oil pump shaft end.

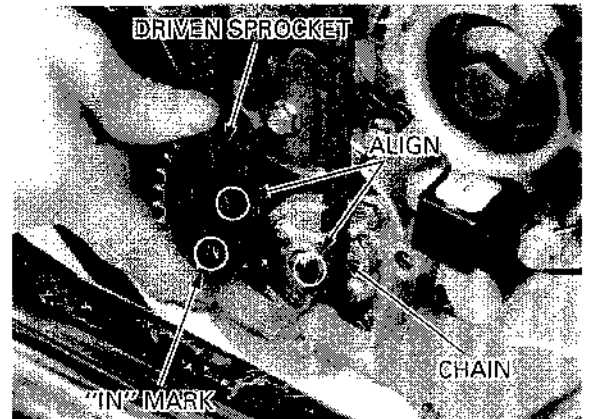

Clean and apply a locking agent to the oil pump driven sprocket bolt threads.  
Install the oil pump driven sprocket bolt.

**NOTE:**

If the oil pump driven sprocket is removed, tighten the driven sprocket bolt to the specified torque after clutch installation.

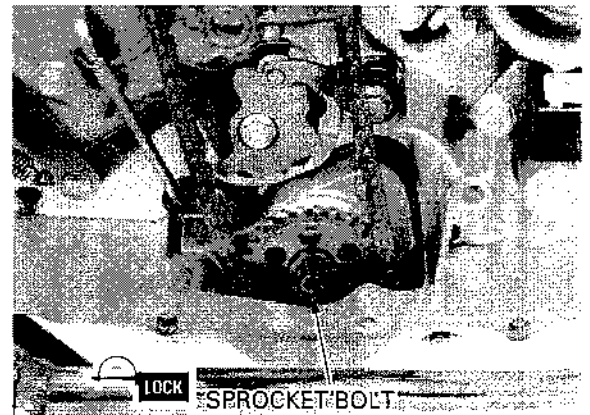

Align the cut-outs in the clutch outer with the tabs on the oil pump drive sprocket while turning the sprocket with the chain and pushing the clutch outer on to the shaft.

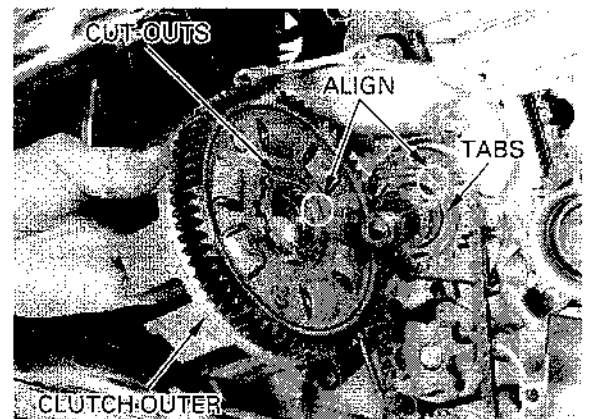

Install the thrust washer onto the mainshaft.

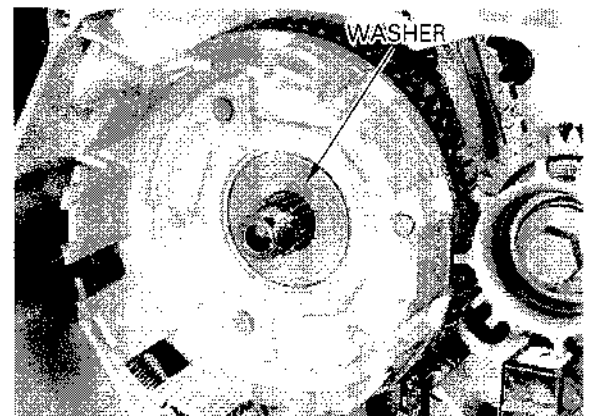

## CLUTCH/GEARSHIFT LINKAGE

Coat the clutch discs and clutch plates with clean engine oil.

Install the clutch disc B, spring seat and judder spring on the clutch center as shown.

Install the six clutch plates and six clutch discs A alternately, starting with a clutch plate to the clutch center.

Install the washer, pressure plate, clutch discs, clutch plates, judder spring, spring seat and clutch center as a set to the clutch outer.

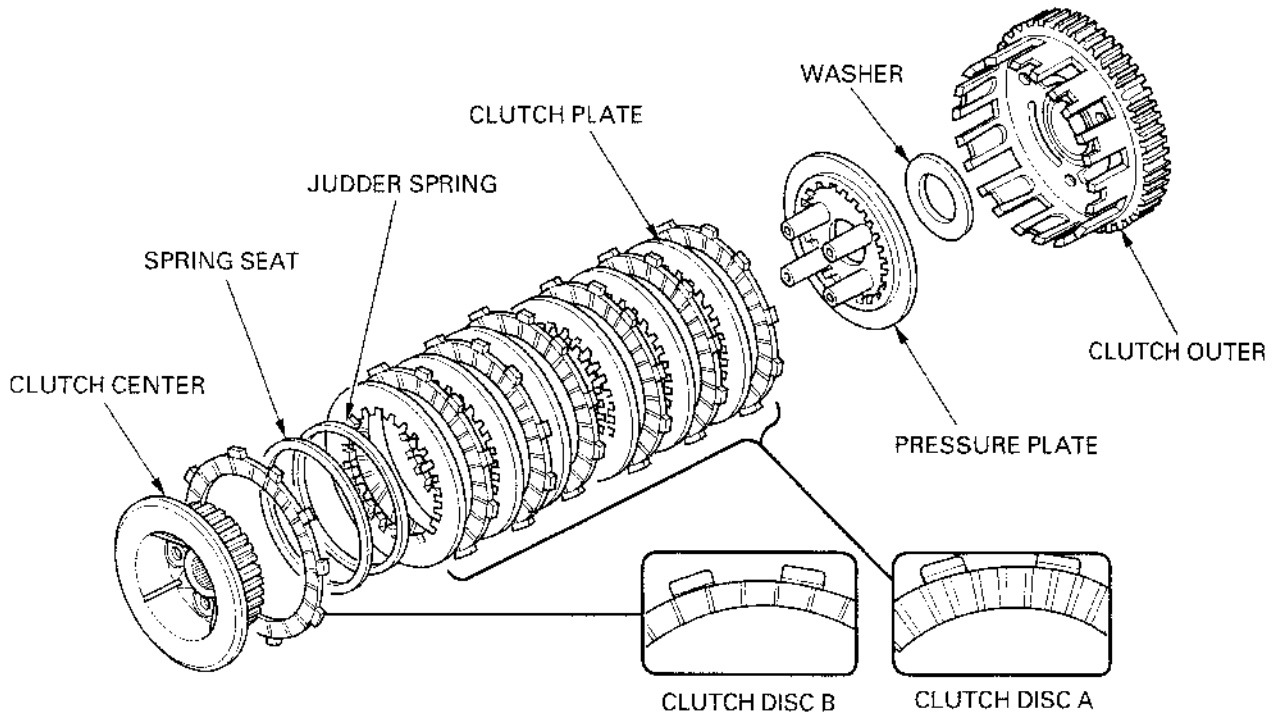
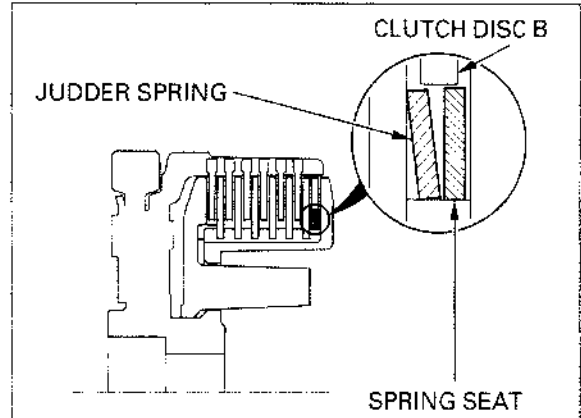

Install the clutch assembly to the mainshaft.  
Install the new spring washer with its "OUT SIDE" mark facing out.

Apply engine oil to new clutch center lock nut threads.

Install the new clutch center lock nut.

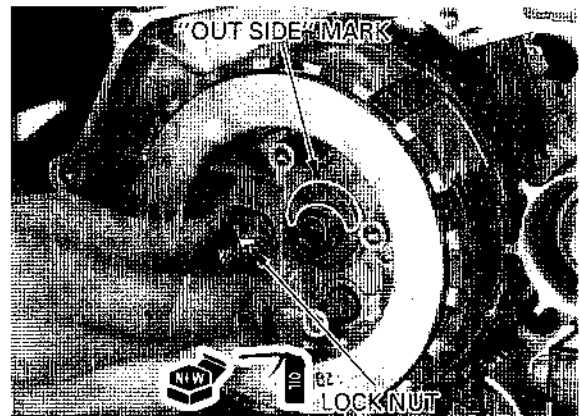

Hold the clutch center with the clutch center holder.

**TOOLS:**

**Clutch center holder**      07JMB-MN50301 or  
07HGB-001010A or  
07HGB-001010B and  
07HGB-001020A  
07HGB-001020B  
(U.S.A. only)

Tighten the lock nut to the specified torque.

**TORQUE:** '97-'98: 127 N·m (13.0 kgf·m , 94 lbf·ft)  
After '98: 128 N·m (13.1 kgf·m , 95 lbf·ft)

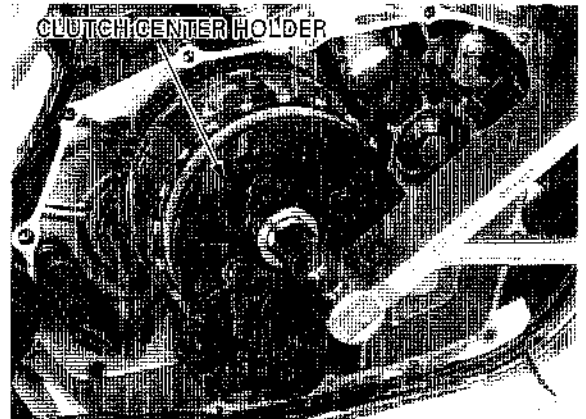

Remove the special tools and stake the lock nut into the mainshaft groove.

**CAUTION:**

*Be careful not to damage the mainshaft threads.*

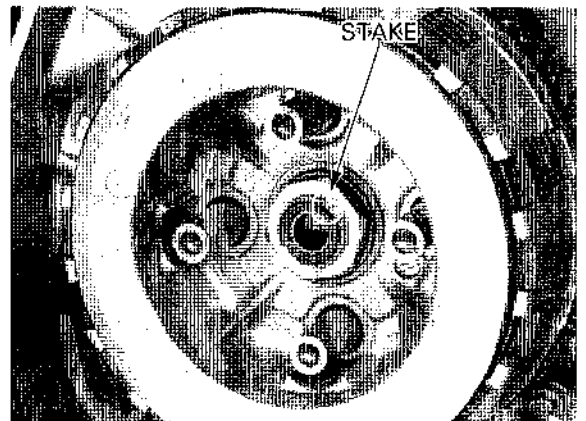

Install the clutch springs and lifter plate/bearing. Install and tighten the clutch lifter plate bolts in a crisscross pattern in several steps.

**TORQUE:** 12 N·m (1.2 kgf·m , 9 lbf·ft)

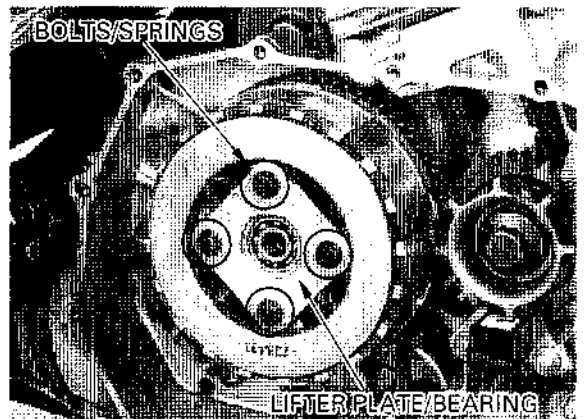

If the oil pump driven sprocket is removed, tighten the driven sprocket bolt to the specified torque.

**TORQUE:** 15 N·m (1.5 kgf·m , 11 lbf·ft)

Install the right crankcase cover (see next page).

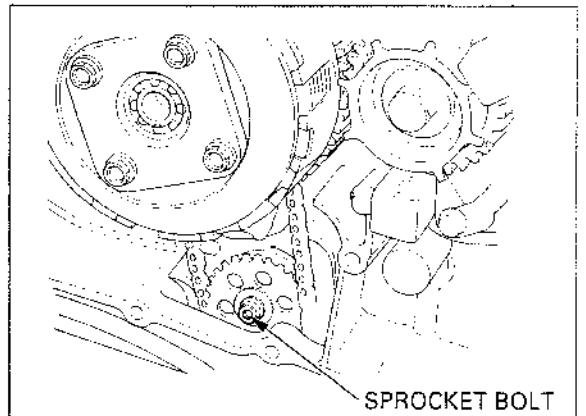

**RIGHT CRANKCASE COVER  
INSTALLATION**

**ASSEMBLY**

Apply grease to the clutch lifter arm pivot needle bearings and dust seal lips.

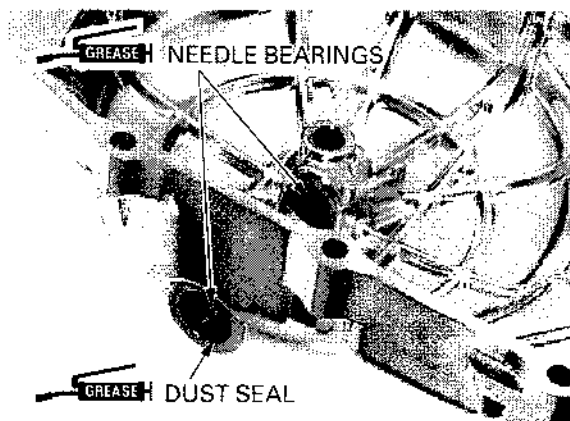

Apply grease to the clutch lifter arm sliding surfaces and slit.  
Install the clutch lifter arm.

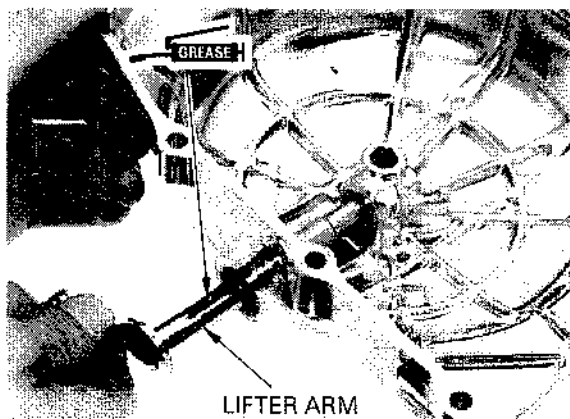

Install the return spring and snap ring.  
Hook the spring end in the cover tab securely, and turn the shaft.

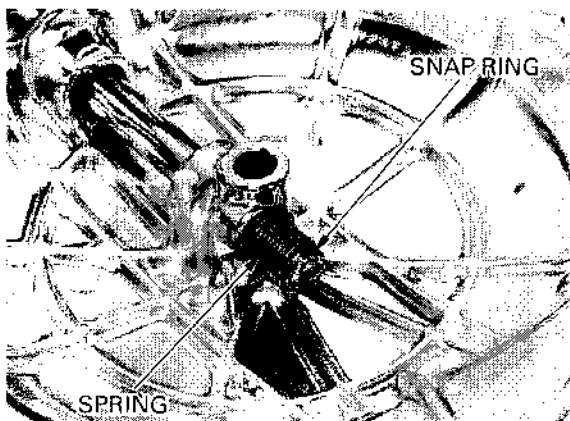

Apply grease to the clutch lifter piece.  
Install the clutch lifter piece, aligning the piece end with the groove in the clutch lifter arm.

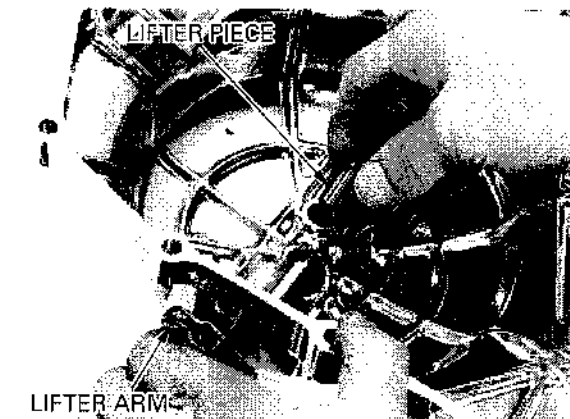

**INSTALLATION**

'97- '98: Install the dowel pins and new gasket.

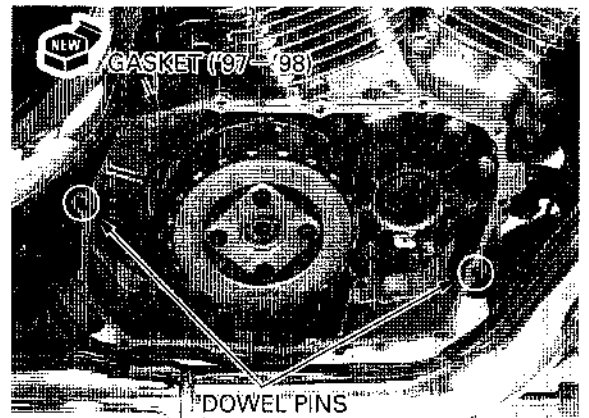

After '98: Clean the right crankcase cover mating surface.  
*Be careful not to damage the mating surface.* Apply sealant well to the right crankcase cover mating surface as shown.

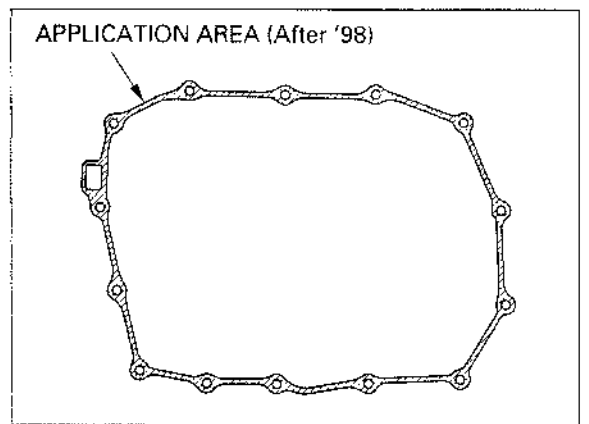

**CAUTION:**

***Do not wipe off the excessive sealant by using the organic solvent.***

Install the dowel pins.

Install the right crankcase cover.  
 Install and tighten the right crankcase cover bolts in a crisscross pattern in several steps.

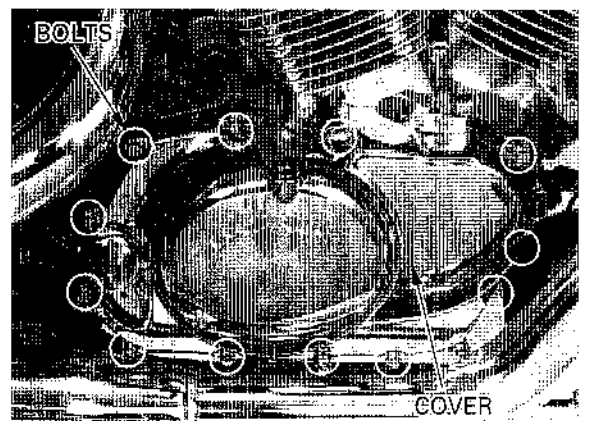

**TORQUE:** 12 N·m (1.2 kgf·m , 9 lbf·ft)

Connect the clutch cable and install the cable holder and bolt.

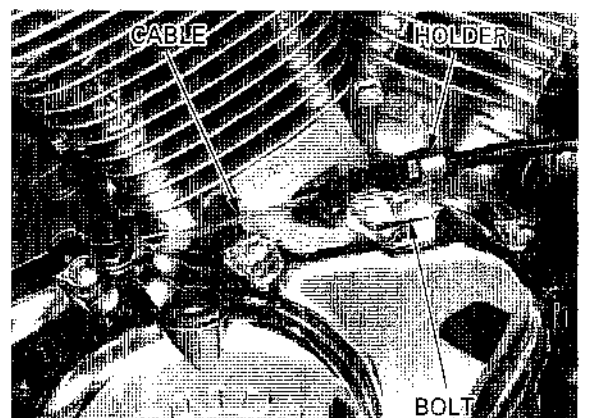

**TORQUE:** 12 N·m (1.2 kgf·m , 9 lbf·ft)

Fill the engine oil (page 3-14).  
 Perform the clutch adjustment (page 3-28).

# ALTERNATOR/STARTER CLUTCH

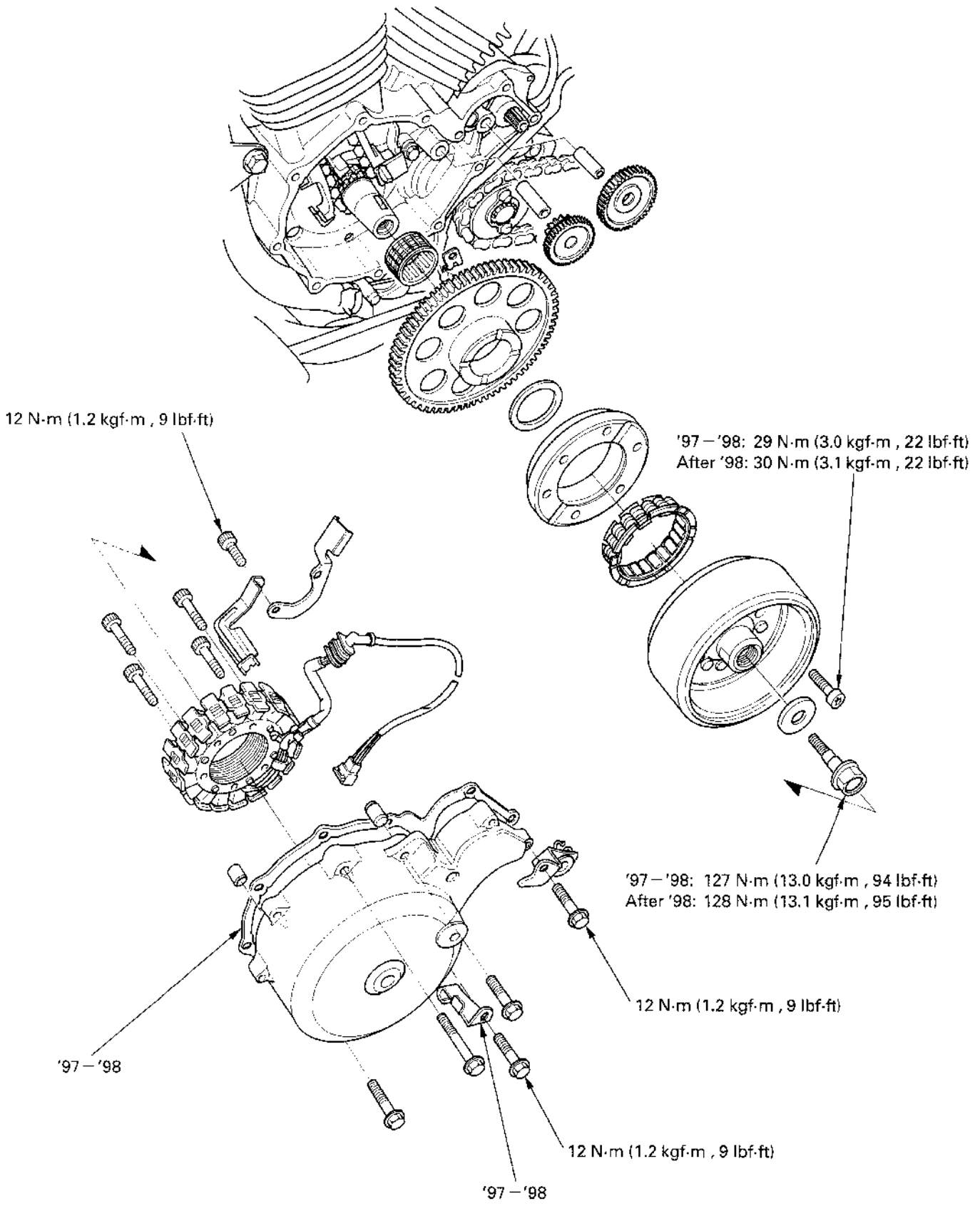



# 9. ALTERNATOR/STARTER CLUTCH

<b>SERVICE INFORMATION</b>	<b>9-1</b>	<b>FLYWHEEL, STARTER CLUTCH</b>	<b>9-3</b>
<b>TROUBLESHOOTING</b>	<b>9-1</b>	<b>STATOR INSTALLATION</b>	<b>9-9</b>
<b>STATOR REMOVAL</b>	<b>9-2</b>		

## SERVICE INFORMATION

### GENERAL

- The alternator and starter clutch maintenance can be done with the engine in the frame.
- Refer to section 16 for alternator inspection.

### SPECIFICATIONS

Unit: mm (in)

ITEM		STANDARD	SERVICE LIMIT
Starter driven gear	I.D.	37.000 – 37.025 (1.4567 – 1.4577)	37.10 (1.461)
	O.D.	57.749 – 57.768 (2.2736 – 2.2743)	57.73 (2.273)
Starter clutch outer I.D.		74.414 – 74.440 (2.9297 – 2.9307)	74.46 (2.931)

9

### TORQUE VALUES

Left crankcase cover bolt	12 N·m (1.2 kgf·m , 9 lbf·ft)	
Flywheel bolt	'97 – '98: 127 N·m (13.0 kgf·m , 94 lbf·ft) After '98: 128 N·m (13.1 kgf·m , 95 lbf·ft)	Left hand threads Apply oil to the threads and seating surface
Starter one-way clutch torx bolt	'97 – '98: 29 N·m (3.0 kgf·m , 22 lbf·ft) After '98: 30 N·m (3.1 kgf·m , 22 lbf·ft)	Apply a locking agent to the threads
Stator mounting socket bolt	12 N·m (1.2 kgf·m , 9 lbf·ft)	Apply a locking agent to the threads
Alternator cord clamber	12 N·m (1.2 kgf·m , 9 lbf·ft)	Apply a locking agent to the threads
Ignition pulse generator bolt	12 N·m (1.2 kgf·m , 9 lbf·ft)	Apply a locking agent to the threads

### TOOLS

Flywheel holder	07725 – 0040000
Rotor puller	07733 – 0020001 or 07933 – 3290001 (U.S.A. only)

## TROUBLESHOOTING

### Starter motor turns, but engine does not turn

- Faulty starter clutch
- Damaged reduction gear
- Damaged starter idle gear

## ALTERNATOR/STARTER CLUTCH

### STATOR REMOVAL

Refer to page 16-7 for alternator (charging coil) inspection. Remove the left side cover (page 2-3) and disconnect the alternator 3P (White) connector.

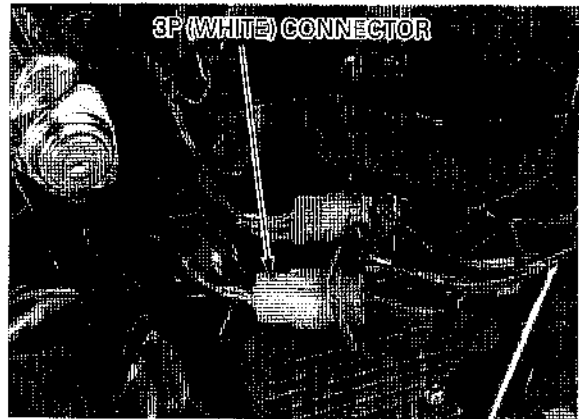

Remove the left rear cover (page 7-4).

Place a container under the left crankcase cover to catch the engine oil.

Loosen the left crankcase cover bolts in a crisscross pattern in several steps. Remove the eleven left crankcase cover bolts and cover.

**CAUTION:**

*The left crankcase cover (stator) is magnetically attached to the flywheel, be careful to removal.*

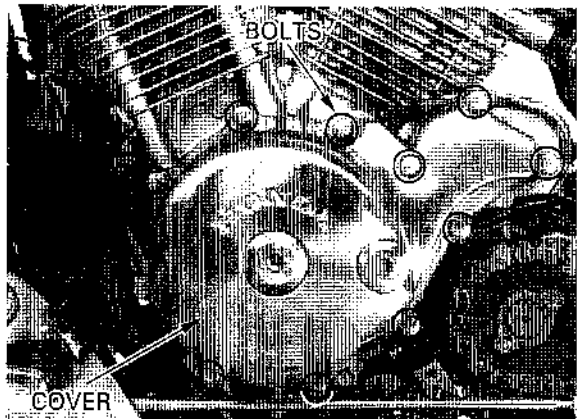

'97 - '98: Remove the gasket and dowel pins.

**NOTE:**

After '98 models have sealant instead of a paper gasket.

After '98: Remove the dowel pins and clean off the sealant from the mating surface. Be careful not to damage the mating surface.

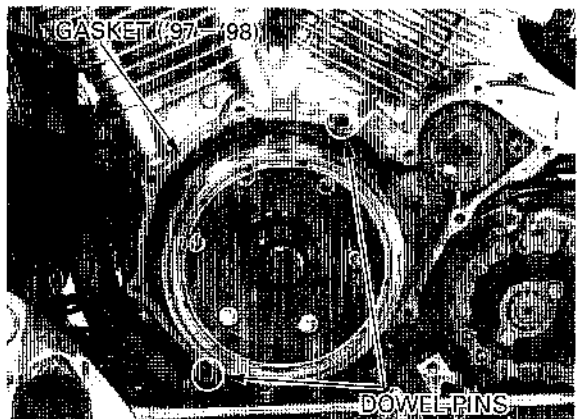

Remove the socket bolts and wire clamp from the left crankcase cover.

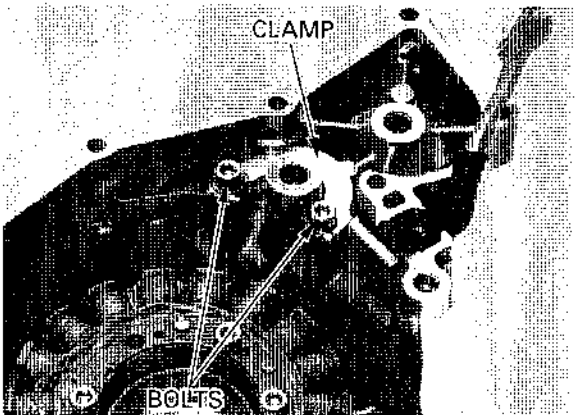

Remove the stator grommets from the left crankcase cover.

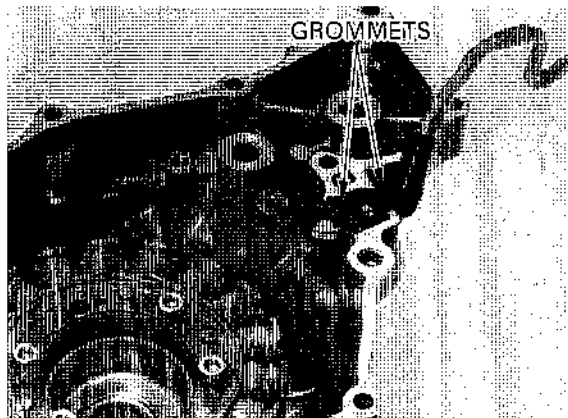

Remove the socket bolts and stator from the left crankcase cover.

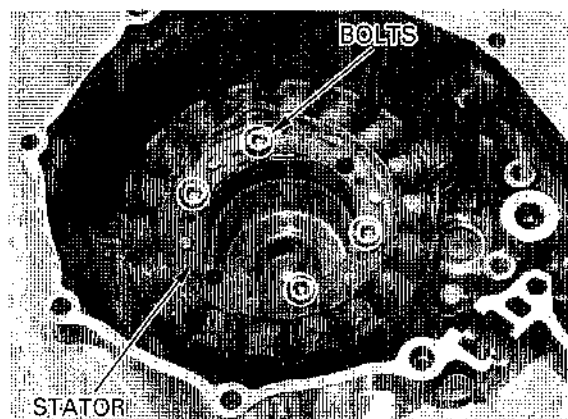

## FLYWHEEL, STARTER CLUTCH

- Refer to page 16-7 for alternator (charging coil) inspection.
- Remove the left crankcase cover (page 9-2).
  - Remove the starter idle gear and shaft.
  - Remove the starter reduction gear and shaft.

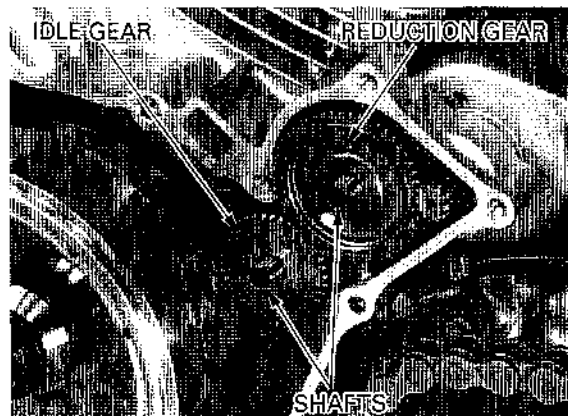

**CAUTION:**

*The flywheel bolt has left hand threads.*

Remove the flywheel bolt and washer while holding the flywheel with a flywheel holder.

**TOOL:**

**Flywheel holder**

07725-0040000  
Equivalent commercially available in U.S.A.

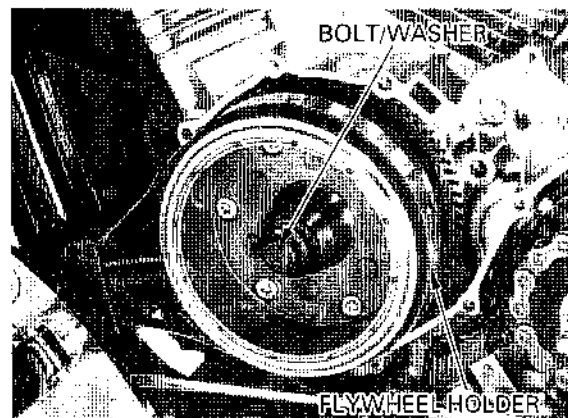

## ALTERNATOR/STARTER CLUTCH

Remove the flywheel using the rotor puller.

**TOOL:**

**Rotor puller**

07733-0020001 or  
07933-3290001  
(U.S.A. only)

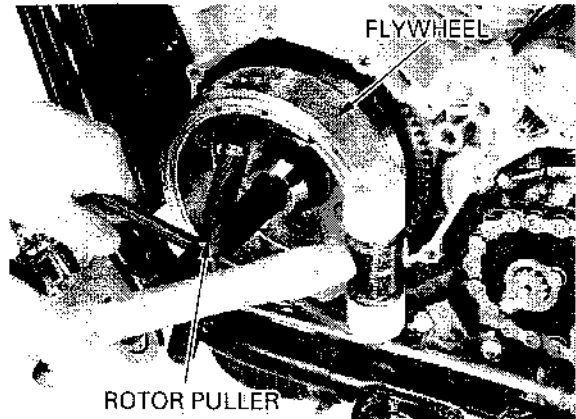

Remove the needle bearing and woodruff key from the crankshaft.

**NOTE:**

- During woodruff key removal, be careful not to damage the key groove or crankshaft.
- Do not lose the woodruff key.

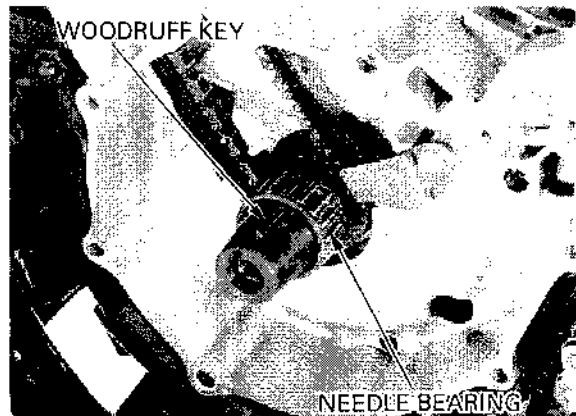

### STARTER DRIVEN GEAR, STARTER CLUTCH REMOVAL

Check that the driven gear turns smoothly in one direction and locks up in the other direction.

Remove the starter driven gear from the flywheel while turning the driven gear counterclockwise.

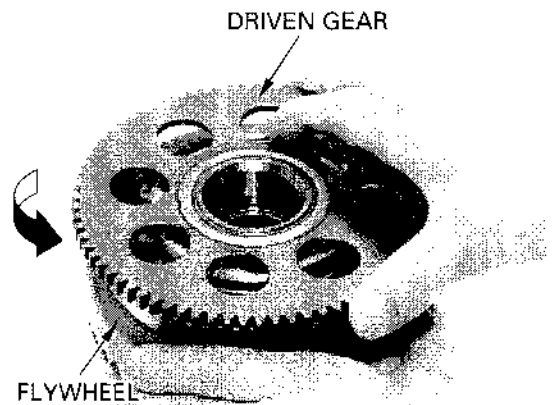

Remove the starter one-way clutch torx bolts while holding the flywheel with a flywheel holder.

**TOOL:**

**Flywheel holder**

07725-0040000  
Equivalent commercially  
available in U.S.A.

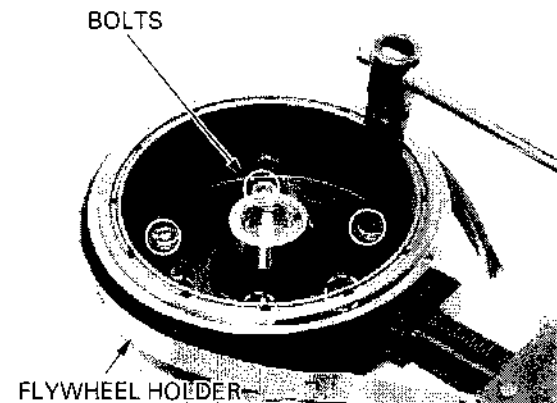

Remove the clutch housing and one-way clutch from the flywheel.  
Remove the washer.

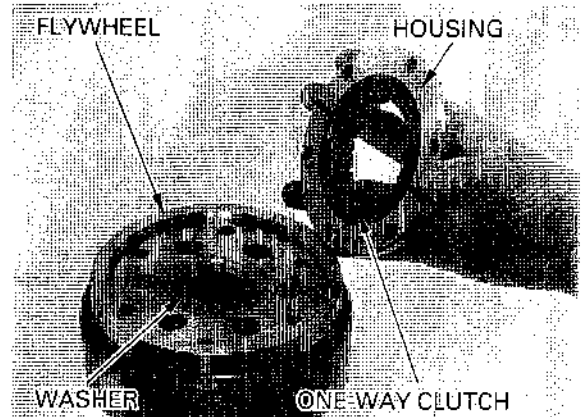

### STARTER CLUTCH INSPECTION

#### NEEDLE BEARING

Check the needle bearing clutch sprag for abnormal wear, damage.

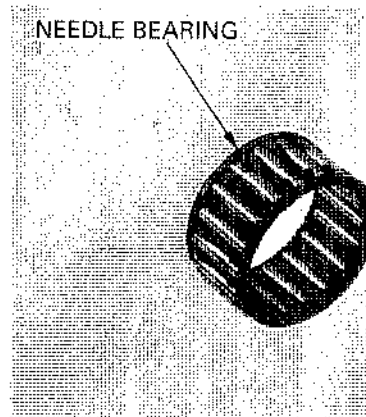

#### ONE-WAY CLUTCH

Check the one-way clutch sprag for abnormal wear, damage or irregular movement.

#### CLUTCH HOUSING

Check the clutch inner contact surface of the housing for damage.

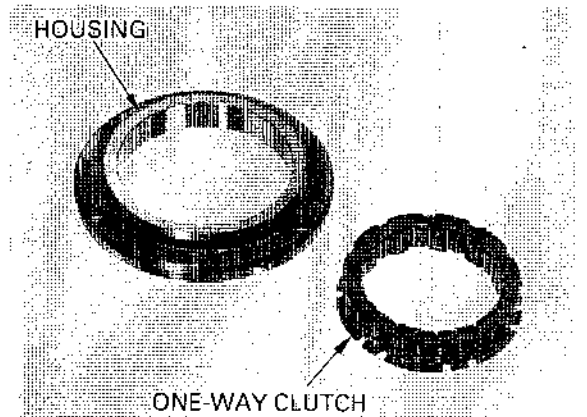

#### STARTER DRIVEN GEAR

Check the roller contact surface for damage.

Measure the driven gear O.D.

**SERVICE LIMIT:** 57.73 mm (2.273 in)

Measure the driven gear I.D.

**SERVICE LIMIT:** 37.10 mm (1.461 in)

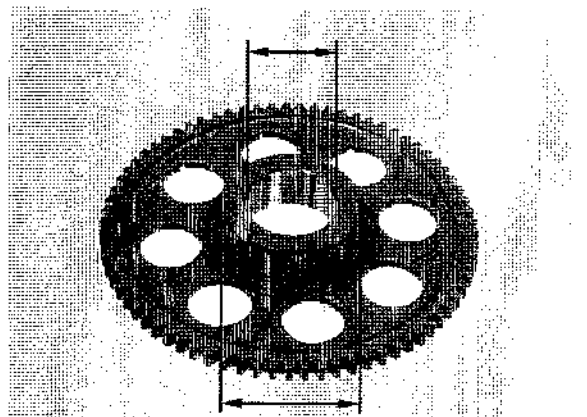

## ALTERNATOR/STARTER CLUTCH

### STARTER DRIVEN GEAR, STARTER CLUTCH INSTALLATION

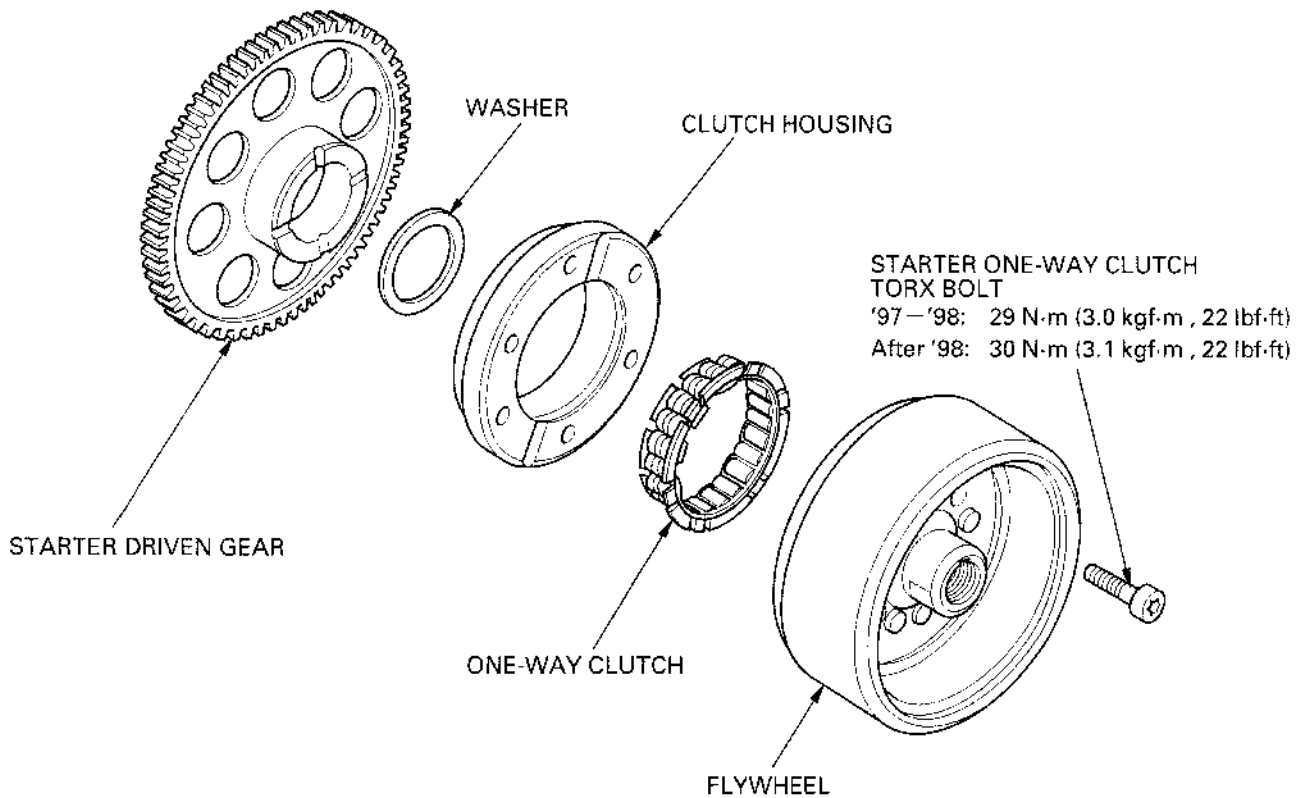

Clean the one-way clutch and apply engine oil to the sprag.  
Install the one-way clutch into the clutch housing with its flange side facing flywheel.

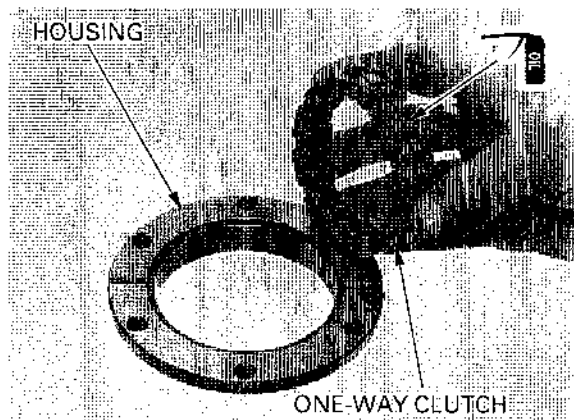

Install the washer.  
Install the clutch housing/one-way clutch to the flywheel.

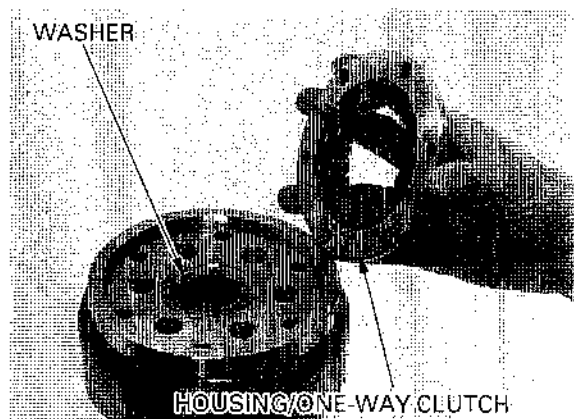

Hold the flywheel using the flywheel holder.

**TOOL:**

**Flywheel holder** 07725--0040000

Clean and apply a locking agent to the starter one-way clutch torx bolt threads.  
Install and tighten the starter one-way clutch torx bolts to the specified torque.

**TORQUE:** '97-'98: 29 N·m (3.0 kgf·m, 22 lbf·ft)  
After '99: 30 N·m (3.1 kgf·m, 22 lbf·ft)

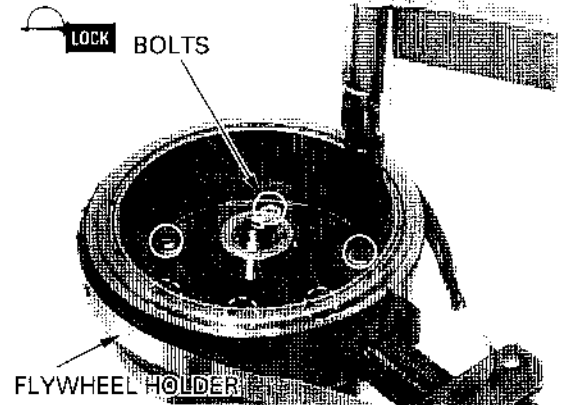

Install the starter driven gear to the flywheel while turning the driven gear counterclockwise.

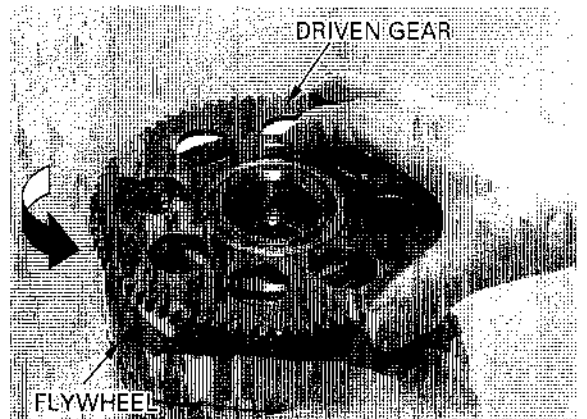

## FLYWHEEL INSTALLATION

*When woodruff key installation, be careful not to damage the key groove or crankshaft.*

Apply engine oil to the needle bearing and install it onto the crankshaft.  
Wipe any oil off the mating surface of the crankshaft.  
Install the woodruff key to the key groove of crankshaft.

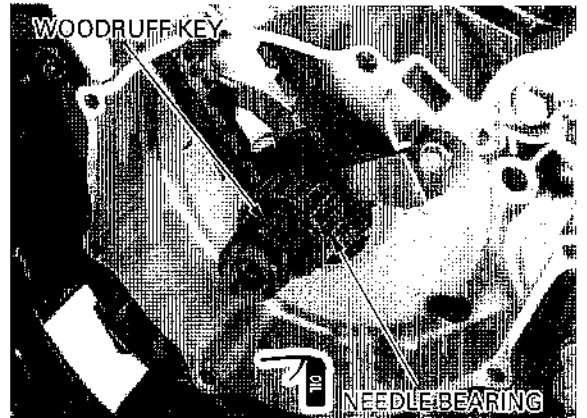

Wipe any oil off the mating surface of the flywheel.  
Install the flywheel to the crankshaft aligning the key groove of the flywheel with the woodruff key on the crankshaft.

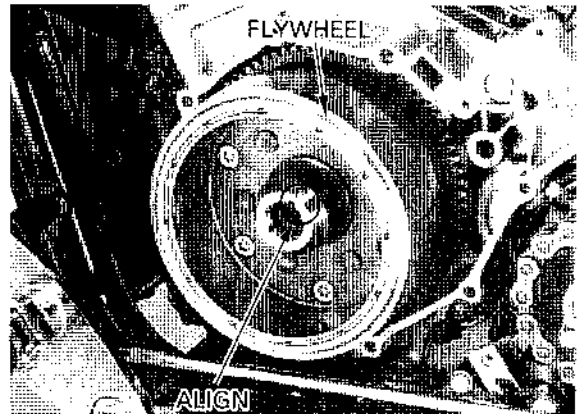

## ALTERNATOR/STARTER CLUTCH

Hold the flywheel using the flywheel holder.

**TOOL:**

**Flywheel holder** 07725 - 0040000  
Equivalent commercially available in U.S.A.

Install the washer.

**CAUTION:**

*The flywheel bolt has left hand threads.*

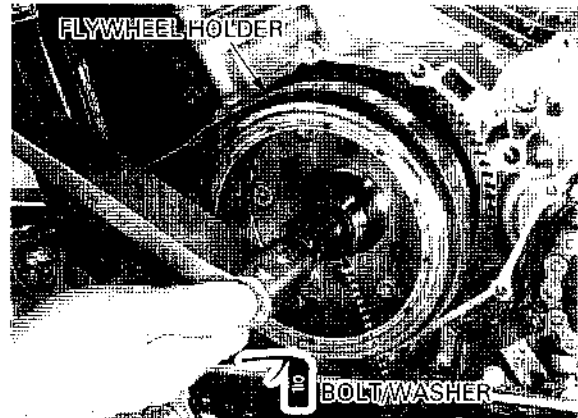

Apply engine oil to the flywheel bolt threads and seating surface.  
Install and tighten the flywheel bolt to the specified torque.

**TORQUE:** '97 - '98: 127 N·m (13.0 kgf·m, 94 lbf·ft)  
After '98: 128 N·m (13.1 kgf·m, 95 lbf·ft)

Check the starter reduction gear, shaft and journal for wear or damage.

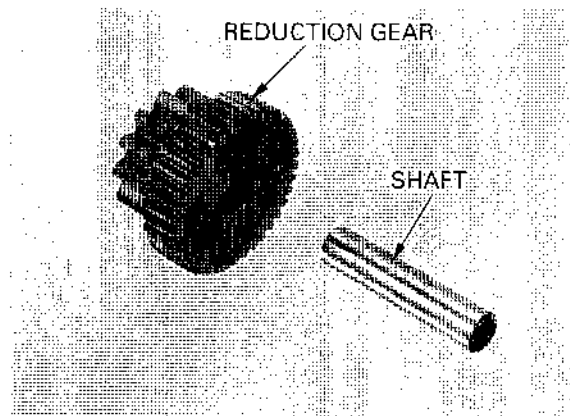

Check the starter idle gear, shaft and journal for wear or damage.

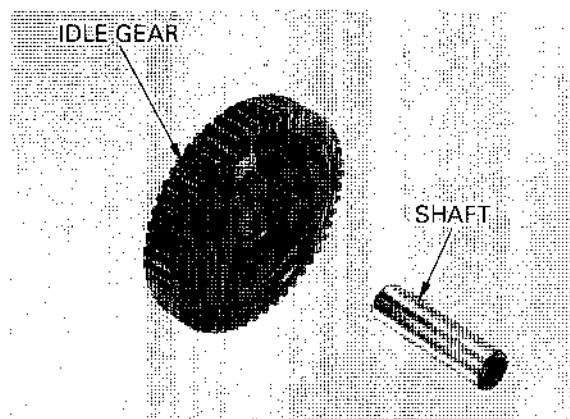

Apply engine oil to the starter reduction gear, starter idle gear and shafts.  
Install the starter reduction gear, starter idle gear and shafts to the left crankcase as assembly.

**NOTE:**

Install the starter reduction gear with its "OUT" mark facing out.

Install the stator and left crankcase cover (page 9-9).

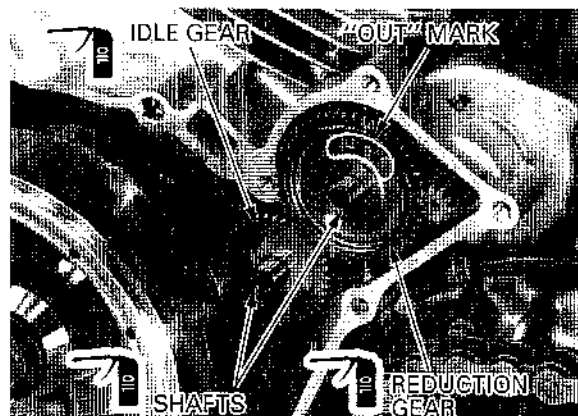



STATOR INSTALLATION

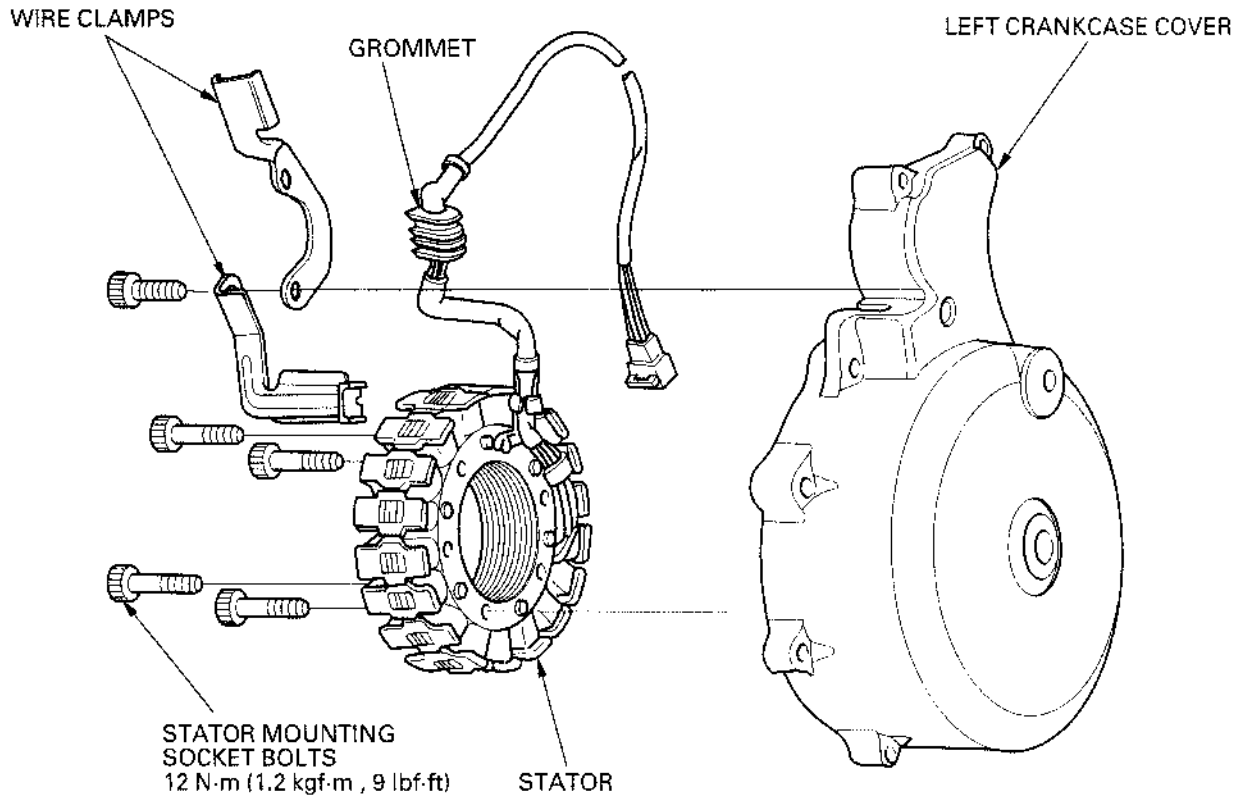

Install the stator to the left crankcase cover. Clean and apply a locking agent to the stator mounting socket bolt threads. Install and tighten the stator mounting socket bolts to the specified torque.

**TORQUE:** 12 N·m (1.2 kgf·m, 9 lbf·ft)

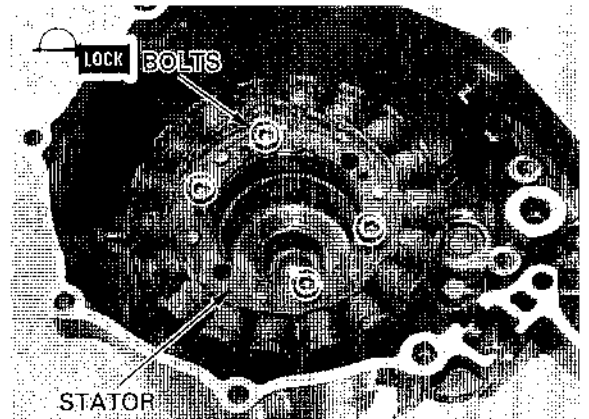

Clean and apply sealant to the wire grommets seating surface and install the grommets into the grooves in the left crankcase cover.

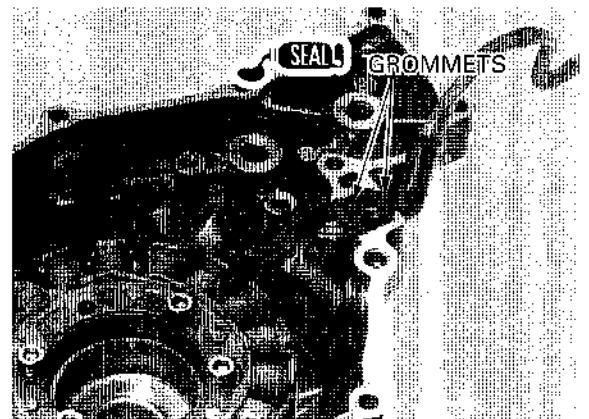

## ALTERNATOR/STARTER CLUTCH

Clean and apply a locking agent to the cord clamp socket bolt threads.  
Install the cord clamp to the left crankcase cover.  
Install and tighten the socket bolt to the specified torque.

**TORQUE:** 12 N·m (1.2 kgf·m , 9 lbf·ft)

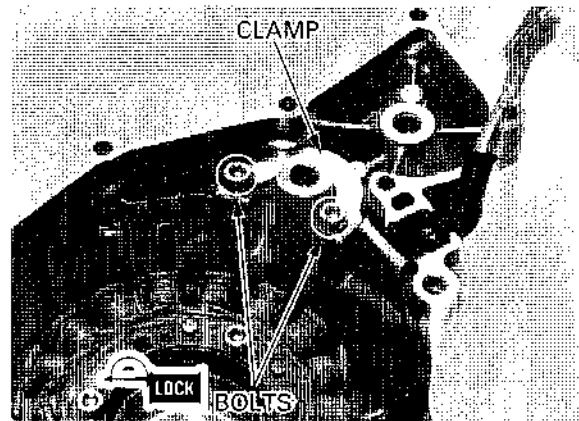

'97- '98: Install the dowel pins and new gasket.

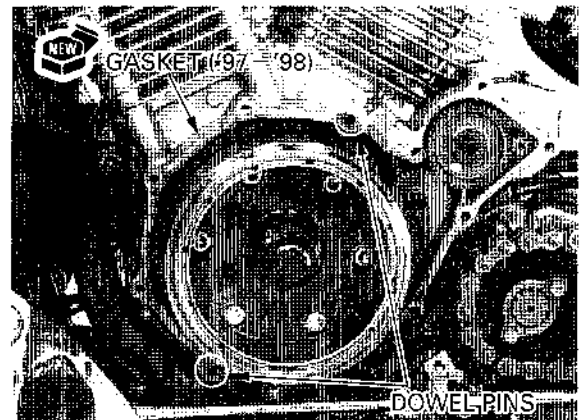

*After '98:* Clean off the sealant from the left crankcase cover mating surface.  
*Be careful not to damage the mating surface.* Apply sealant well to the left crankcase cover mating surface.

### CAUTION:

***Do not wipe off the excessive sealant by using the organic solvent.***

Install the dowel pins.

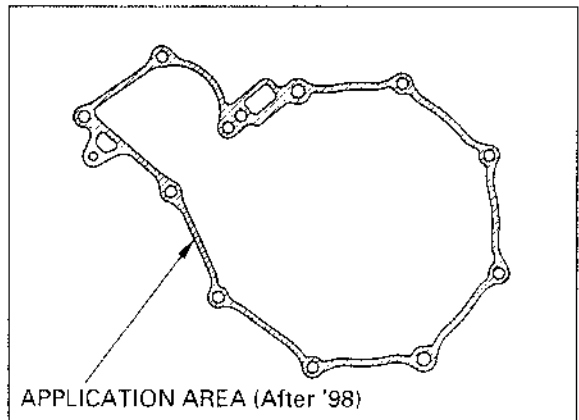

Install the left crankcase cover.

### NOTE:

The left crankcase cover (stator) is magnetically attached to the flywheel, so be careful during installation.

Install and tighten the left crankcase cover bolts to the specified torque in a crisscross pattern in several steps.

**TORQUE:** 12 N·m (1.2 kgf·m , 9 lbf·ft)

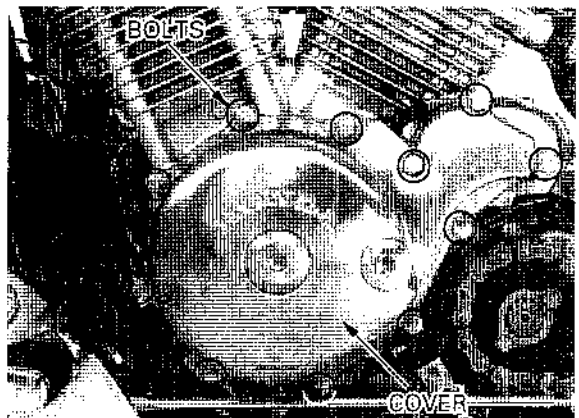

**NOTE:**

Route the wire harness properly (page 1-24, 28).

Install the clamps onto the wires.

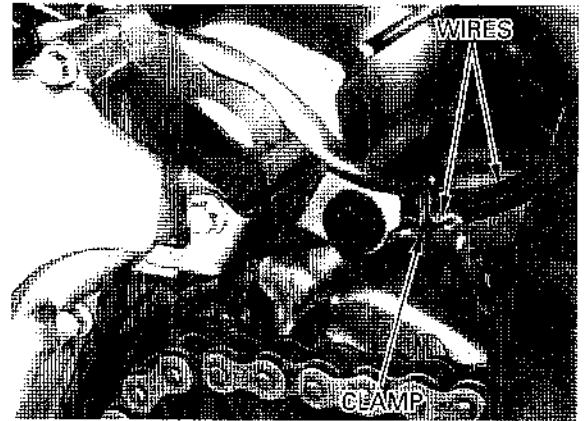

Connect the alternator 3P (White) connector.

Install the left rear cover (page 7-15).

Install the left side cover (page 2-3).

Check the engine oil level (page 3-14).

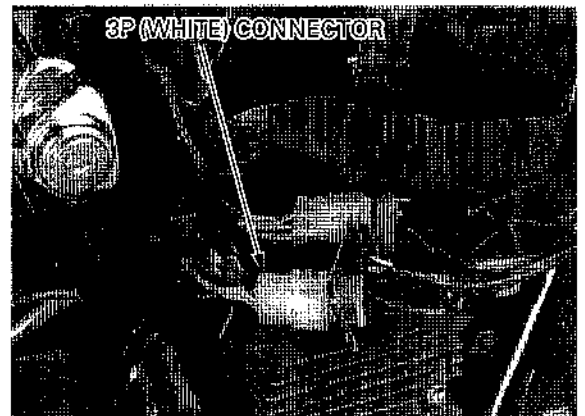

# CYLINDER HEAD/VALVES

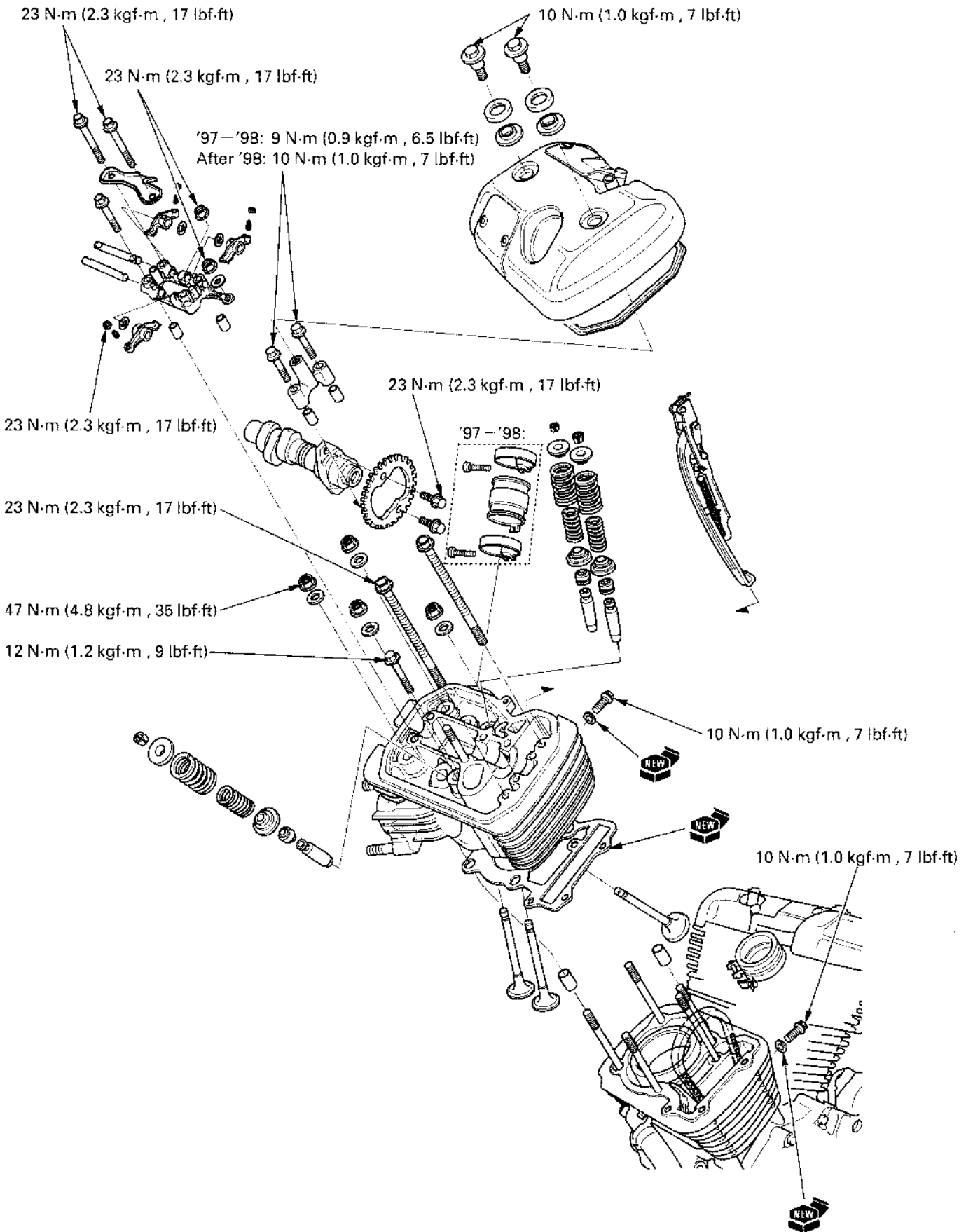

# 10. CYLINDER HEAD/VALVES

SERVICE INFORMATION	10-1	VALVE GUIDE REPLACEMENT	10-17
TROUBLESHOOTING	10-3	VALVE SEAT INSPECTION/REFACING	10-19
CYLINDER COMPRESSION	10-4	CYLINDER HEAD ASSEMBLY	10-21
CYLINDER HEAD COVER REMOVAL	10-5	CYLINDER HEAD INSTALLATION	10-23
CAMSHAFT REMOVAL	10-7	CAMSHAFT INSTALLTION	10-25
CYLINDER HEAD REMOVAL	10-13	CYLINDER HEAD COVER INSTALLATION	10-31
CYLINDER HEAD DISASSEMBLY	10-14		

## SERVICE INFORMATION

### GENERAL

- The engine must be removed from the frame before servicing the rear cylinder head.
- The front and rear cylinder head cover and front cylinder head can be serviced with the engine in the frame.
- The camshaft can be serviced with the engine in the frame.
- Be careful not to damage the mating surfaces when removing the cylinder head cover and cylinder head.
- When disassembling, mark and store the disassembled parts to ensure that they are reinstalled in their original locations.
- Clean all disassembled parts with clean solvent and dry them using compressed air before inspection.
- During assembly apply molybdenum disulfid oil to the camshaft holders, camshaft journals of the cylinder head, rocker arm shafts, rocker arm slipper faces and valve stems to provide initial lubrication.

10

### SPECIFICATIONS

Unit: mm (in)

ITEM			STANDARD	SERVICE LIMIT	
Cylinder compression			1,324 ± 98 kPa (13.5 ± 1.0 kgf/cm <sup>2</sup> , 192 ± 14 psi) at 400 rpm	-----	
Cylinder head warpage			-----	0.10 (0.004)	
Valve, valve guide	Valve clearance	IN	0.15 (0.006)	-----	
		EX	0.20 (0.008)	-----	
	Valve stem O.D.	IN	5.475 - 5.490 (0.2156 - 0.2161)	5.45 (0.215)	
		EX	6.555 - 6.570 (0.2581 - 0.2587)	6.55 (0.258)	
	Valve guide I.D.	IN	5.500 - 5.512 (0.2165 - 0.2170)	5.56 (0.219)	
		EX	6.600 - 6.615 (0.2598 - 0.2604)	6.65 (0.262)	
	Stem-to-guide clearance	IN	0.010 - 0.037 (0.0004 - 0.0015)	0.10 (0.004)	
		EX	0.030 - 0.060 (0.0012 - 0.0024)	0.11 (0.004)	
Valve guide projection above cylinder head	IN	19.4 - 19.6 (0.76 - 0.77)	-----		
	EX	17.9 - 18.1 (0.70 - 0.71)	-----		
Valve seat width		IN/EX	0.90 - 1.10 (0.035 - 0.043)	1.5 (0.06)	
Valve spring free length	Inner	IN	38.11 (1.500)	36.47 (1.436)	
		EX	38.81 (1.528)	37.51 (1.477)	
	Outer	IN	42.14 (1.659)	40.58 (1.598)	
		EX	42.83 (1.686)	41.25 (1.624)	
Camshaft	Cam lobe height	IN	'97-'98	37.930 (1.4933)	37.73 (1.485)
			After '98	37.188 - 37.348 (1.4641 - 1.4704)	37.16 (1.463)
		EX	'97-'98	37.950 (1.4941)	37.75 (1.486)
			After '98	37.605 - 37.765 (1.4805 - 1.4868)	37.58 (1.480)
	Journal O.D.			21.959 - 21.980 (0.8645 - 0.8654)	21.90 (0.862)
	Runout			0.030 (0.0012)	0.05 (0.002)
	Oil clearance			0.050 - 0.111 (0.0020 - 0.0044)	0.13 (0.005)
Identification marks			"F": Front, "R": Rear	-----	
Rocker arm I.D.		IN/EX	12.000 - 12.018 (0.4724 - 0.4731)	12.05 (0.474)	
Rocker arm shaft O.D.		IN/EX	11.966 - 11.984 (0.4711 - 0.4718)	11.91 (0.469)	
Rocker arm-to-rocker arm shaft clearance			0.016 - 0.052 (0.0006 - 0.0020)	0.07 (0.003)	

## CYLINDER HEAD/VALVES

---

### TORQUE VALUES

Spark plug	14 N·m (1.4 kgf·m , 10 lbf·ft)	
Cylinder head cover bolt	10 N·m (1.0 kgf·m , 7 lbf·ft)	
Valve adjust cover bolt	12 N·m (1.2 kgf·m , 9 lbf·ft)	
Valve adjusting screw lock nut	23 N·m (2.3 kgf·m , 17 lbf·ft)	Apply oil to the threads and seating surface
Cam sprocket bolt	23 N·m (2.3 kgf·m , 17 lbf·ft)	Apply a locking agent to the threads
Camshaft holder 8 mm bolt	23 N·m (2.3 kgf·m , 17 lbf·ft)	
8 mm nut	23 N·m (2.3 kgf·m , 17 lbf·ft)	
Camshaft end holder bolt	'97-'98: 9 N·m (0.9 kgf·m , 6.5 lbf·ft)	
	After '98: 10 N·m (1.0 kgf·m , 7 lbf·ft)	
Cam chain tensioner mounting bolt	10 N·m (1.0 kgf·m , 7 lbf·ft)	Apply a locking agent to the threads
Cylinder head 8 mm bolt	23 N·m (2.3 kgf·m , 17 lbf·ft)	Apply oil to the threads and seating surface
6 mm bolt	12 N·m (1.2 kgf·m , 9 lbf·ft)	Apply oil to the threads and seating surface
10 mm nut	47 N·m (4.8 kgf·m , 35 lbf·ft)	

### TOOLS

Valve guide driver, 5.5 mm (IN)	07742 - 0010100	
Valve guide driver, 6.6 mm (EX)	07742 - 0010200	Not available in U.S.A. or 07942 - 6570100
Valve spring compressor	07757 - 0010000	or 07957 - 3290001
Valve seat cutter (Commercially available in U.S.A.)		
Seat cutter	IN 27.5 mm (45°)	07780 - 0010200
	EX 35 mm (45°)	07780 - 0010400
— Flat cutter	IN 28 mm (32°)	07780 - 0012100
	EX 35 mm (32°)	07780 - 0012300
— Interior cutter	IN 30 mm (60°)	07780 - 0014000
	EX 37.5 mm (60°)	07780 - 0014100
— Cutter holder	IN 5.5 mm	07781 - 0010101
	EX 6.6 mm	07781 - 0010201
Valve guide driver attachment (IN)	07943 - MF50100	
Valve guide driver attachment (EX)	07943 - MF50200	
Valve guide reamer (IN)	07984 - 2000001	or 07984 - 200000D
Valve guide reamer (EX)	07984 - ZE20001	or 07984 - ZE2000D

## **TROUBLESHOOTING**

- Engine top-end problems usually affect engine performance. These can be diagnosed by a compression test, or by tracking noises to the top-end.
- If performance is poor at low speeds, check for white smoke in the crankcase breather tube. If the tube is smoky, check for a seized piston ring.

### **Compression too low, hard starting or poor performance at low speed**

- Valves
  - Incorrect valve adjustment
  - Burned or bent valves
  - Incorrect valve timing
  - Broken valve spring
  - Uneven valve seating
- Cylinder head
  - Leaking or damaged cylinder head gasket
  - Warped or cracked cylinder head
- Loose spark plug
- Faulty cylinder, piston (Section 11)

### **Compression too high**

- Excessive carbon build-up in cylinder head or on top of piston

### **Excessive smoke**

- Worn valve stem or valve guide
- Damaged stem seal
- Faulty cylinder, piston (Section 11)

### **Excessive noise**

- Incorrect valve adjustment
- Sticking valve or broken valve spring
- Damaged or worn camshaft
- Loose or worn cam chain
- Worn or damaged cam chain tensioner
- Worn cam sprocket teeth
- Faulty cylinder, piston (Section 11)

### **Rough idle**

- Low cylinder compression

### CYLINDER COMPRESSION

#### ▲WARNING

*If the engine must be running to do some work, make sure the area is well-ventilated. Never run the engine in an enclosed area.*

Warm up the engine to normal operating temperature.

Stop the engine, disconnect the spark plug caps and remove one spark plug cap at a time.

#### NOTE:

To measure the cylinder compression of each cylinder, remove only one plug at a time.

Shift the transmission into neutral.  
Install the compression gauge attachment in a spark plug hole.

Connect the compression gauge to the attachment. Open the throttle all the way and crank the engine with the starter motor.

#### NOTE:

Crank the engine until the gauge reading stops rising. The maximum reading is usually reached within 4–7 seconds.

**STANDARD:**  $1,324 \pm 98$  kPa ( $13.5 \pm 1.0$  kgf/cm<sup>2</sup>,  
 $192 \pm 14$  psi) at 400 rpm

If compression is high, it indicates that carbon deposits have accumulated on the combustion chamber and/or the piston crown.

If compression is low, pour 3–5 cc (0.1–0.2 oz) of clean engine oil into the cylinder through the spark plug hole and recheck the compression.

If the compression increases from the previous value, check the cylinder, piston and piston rings.

- Leaking cylinder head gasket
- Worn piston ring
- Worn cylinder and piston

If compression is the same as the previous value, check the valves for leakage.

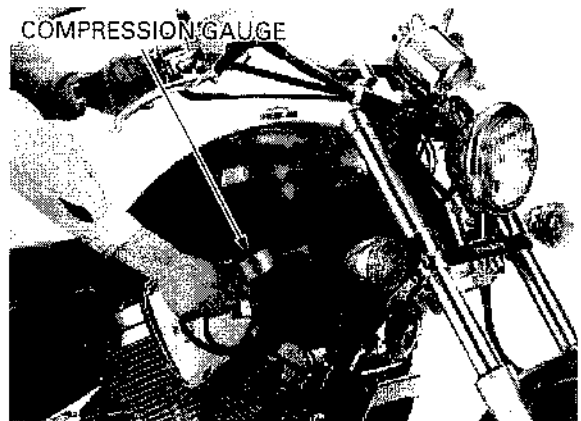
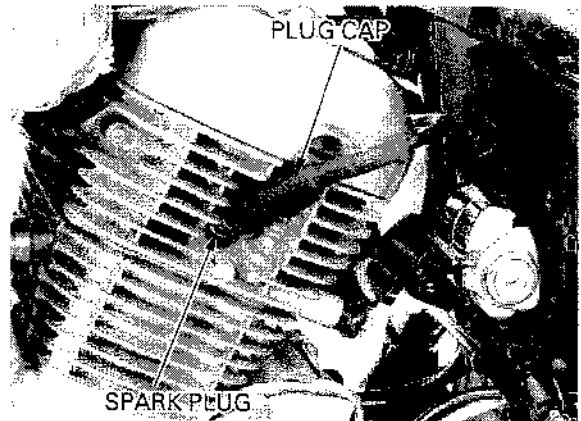



## CYLINDER HEAD COVER REMOVAL

### FRONT

- Drain the coolant (page 6-6).
- Remove the steering covers (page 2-3).
- Remove the fuel tank (page 2-4).
- Remove the air cleaner housing (page 5-4).
- Remove the carburetors ('97 - '98: page 5-10).

Disconnect the spark plug caps.

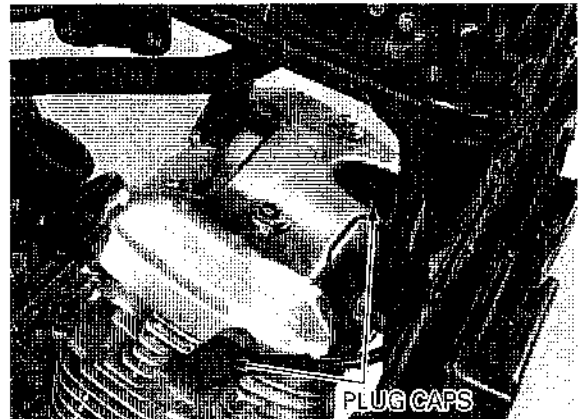

Remove the water pipe mounting bolt, front water pipe and O-ring.

**NOTE:**

If coolant drips on the engine, wipe it off immediately.

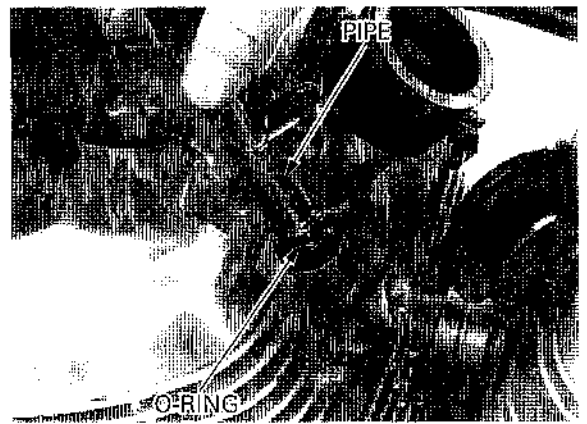

Remove the cylinder head cover bolts, washers and rubber seals.

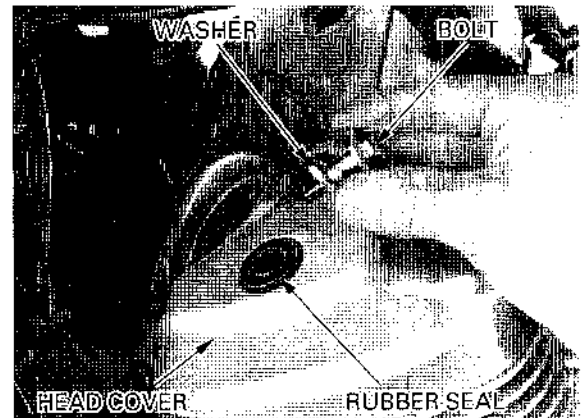

*Be careful not to damage the wire harness and mating surfaces when removing the cylinder head cover.*

Remove the cylinder head cover and gasket.



## CYLINDER HEAD/VALVES

### REAR

Drain the coolant (page 6-6).  
Remove the steering covers (page 2-3).  
Remove the fuel tank (page 2-4).  
Remove the air cleaner housing (page 5-4).  
Remove the carburetor(s) ('97 '98: page 5-10,  
After '98: page 5-11).  
Remove the inlet manifold (After '98: page 7-8).

Remove the socket bolts and valve adjusting cover.

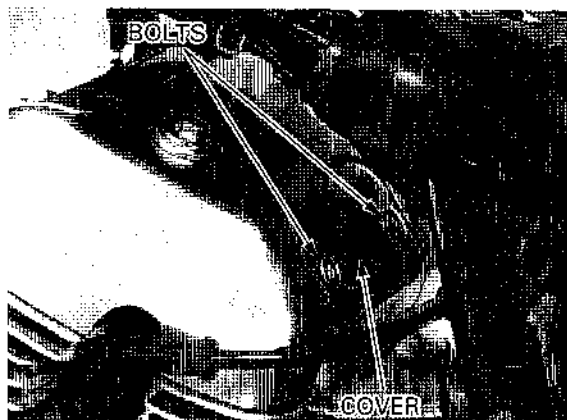

Disconnect the spark plug caps and crankcase breather tube.

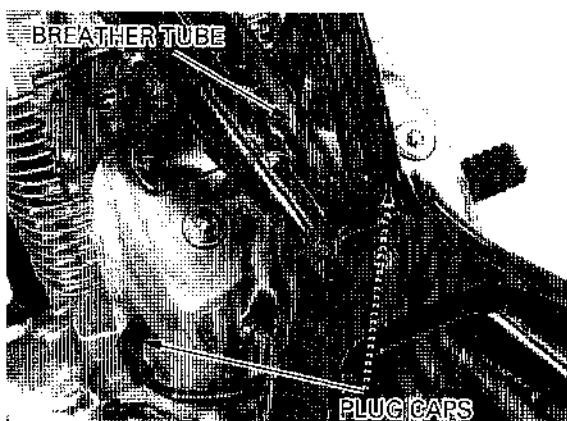

Remove the water pipe mounting bolt, rear water pipe and O-ring.

#### NOTE:

If coolant drips on the engine, wipe it off immediately.

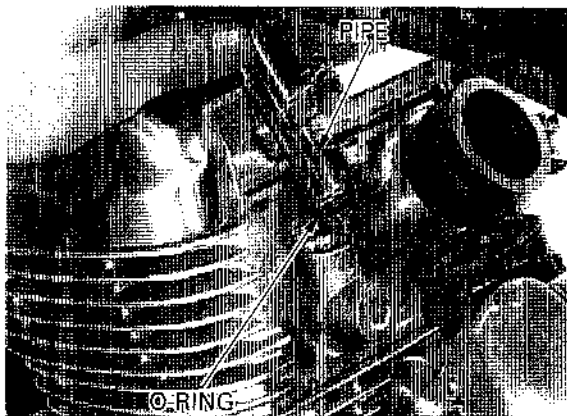

Remove the cylinder head cover bolts, washers and rubber seals.

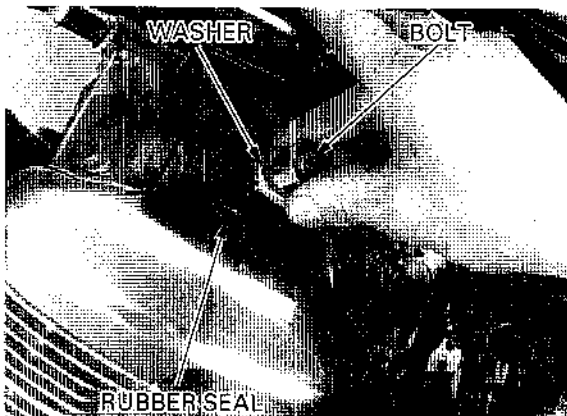

*Be careful not to damage the wire harness and mating surfaces when removing the cylinder head cover.*

Align the wire harness with the valve adjusting hole, then remove the rear cylinder head cover to forward.

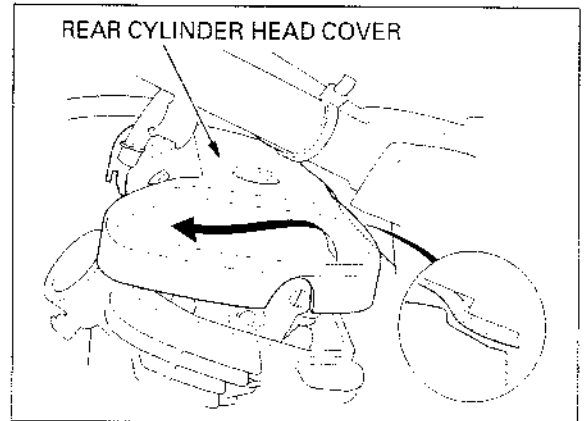

## **CAMSHAFT REMOVAL**

**NOTE:**

- The camshaft can be serviced with the engine in the frame.
- The rear cylinder camshaft service procedure is the same as the front cylinder camshaft service procedure.

Remove the front cylinder head cover (page 10-5).

Remove the crankshaft hole cap and timing hole cap from the left crankcase cover.

Remove the camshaft end holder bolts and camshaft end holder.

Remove the dowel pins.

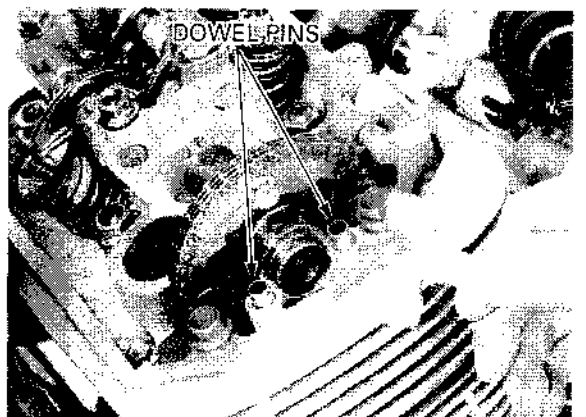
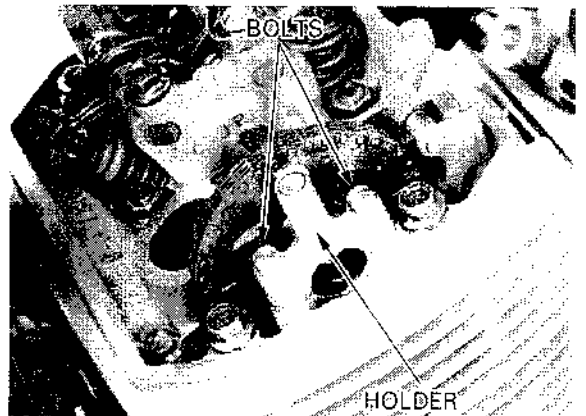
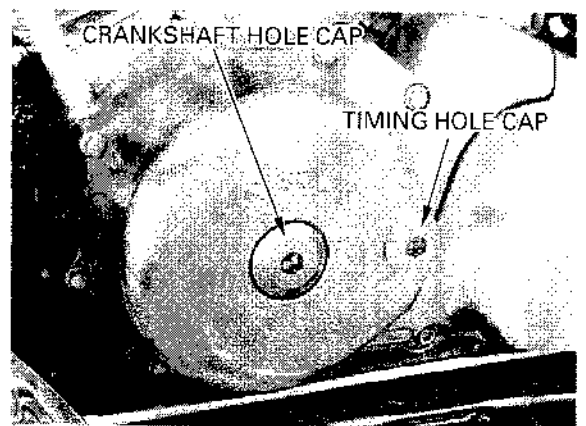

## CYLINDER HEAD/VALVES

Turn the crankshaft counterclockwise and align the "FT" mark (rear cylinder: "RT" mark) with the index mark on the left crankcase cover. Make sure the rear cylinder is at TDC (top dead center).

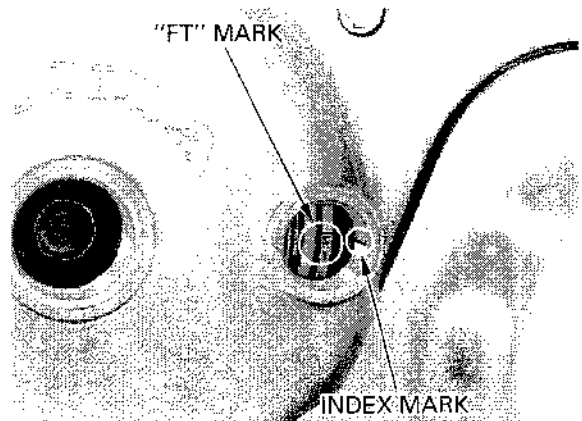

Measure the cam chain tensioner wedge B length as shown.

**SERVICE LIMIT:** 6 mm (0.2 in)

When the service limit is exceeded, replace the cam chain.

The cam chain can be replaced after removing the following parts:

Front:

- Front camshaft
- Flywheel (Section 9)

Rear:

- Rear camshaft
- Primary drive gear (Section 8)

Pull the cam chain tensioner wedge A straight up while holding wedge B down. Secure wedge A with a 2 mm pin as shown.

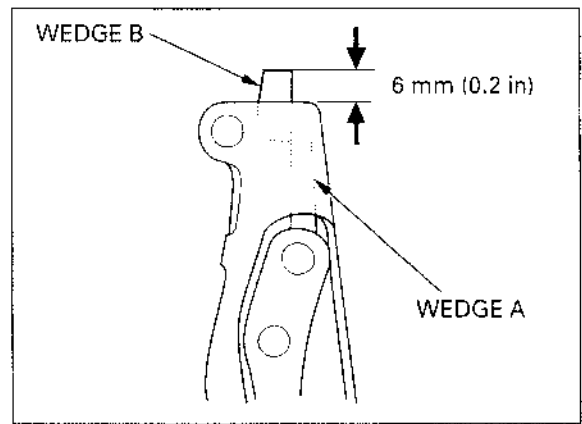

**NOTE**

Be careful not to let the 2 mm pin fall into the crankcase.

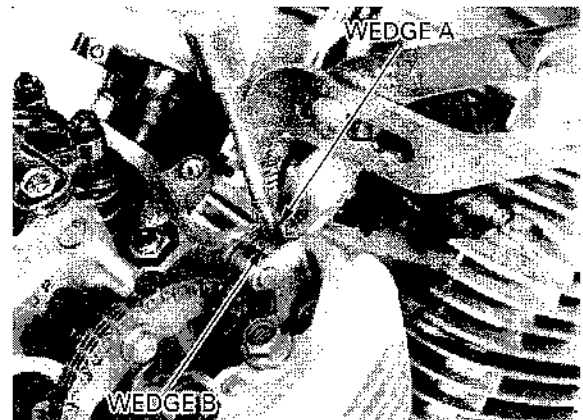

Remove the cam sprocket bolt, turn the crankshaft counterclockwise one full turn (360°) and remove the other cam sprocket bolt.

**NOTE**

Be careful not to let the cam sprocket bolts fall into the crankcase.

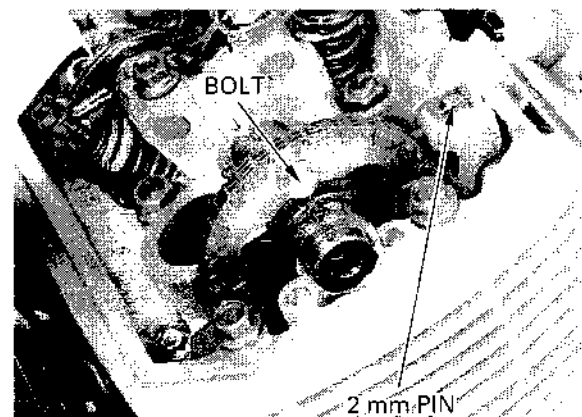

Remove the cam sprocket from the camshaft flange surface.

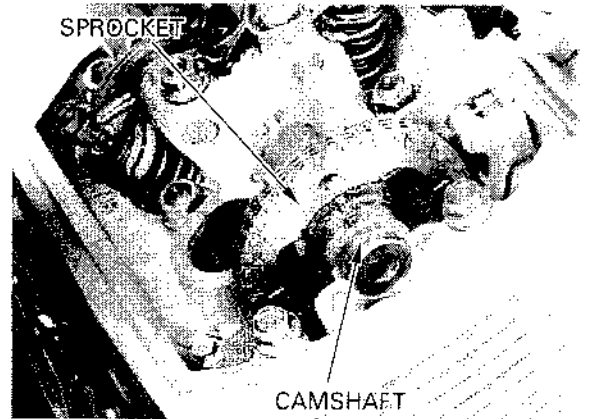

Remove the camshaft holder nuts (8 mm)/washer.  
Remove the camshaft holder bolts (8 mm) and oil guide plate.  
Remove the camshaft holder assembly.

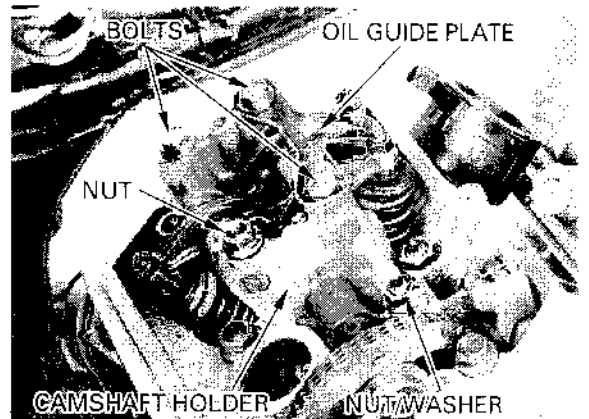

Remove the dowel pins.

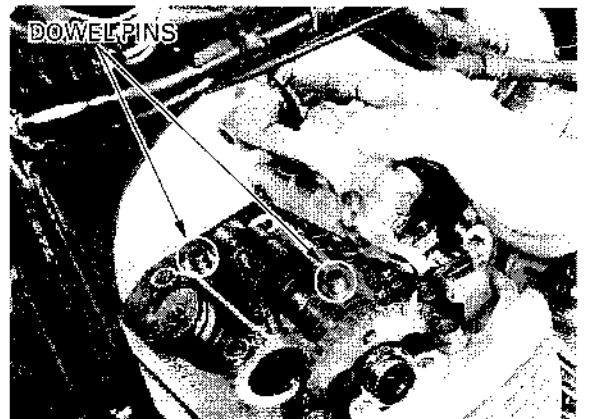

Remove the camshaft.

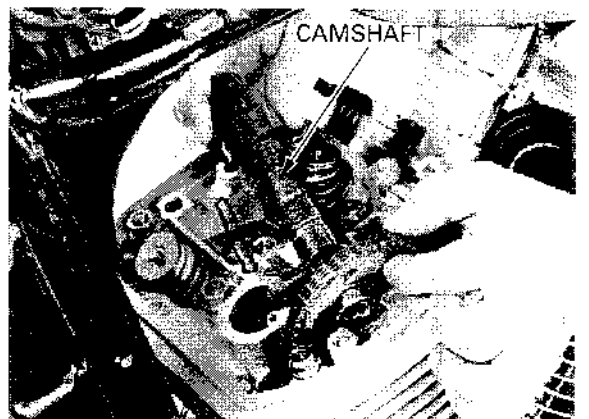

## CYLINDER HEAD/VALVES

Remove the cam sprocket from cam chain.  
Attach a piece of mechanic's wire to the cam chain to prevent it from being dropped into the crankcase.

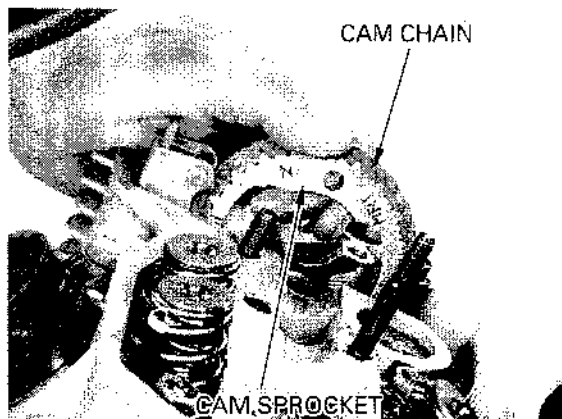

### CAMSHAFT HOLDER DISASSEMBLY

#### NOTE:

The rear cylinder camshaft holder service uses the same procedure as the front cylinder camshaft holder.

Remove the exhaust rocker arm shaft, exhaust rocker arm and wave washer from the camshaft holder.

< EXHAUST >

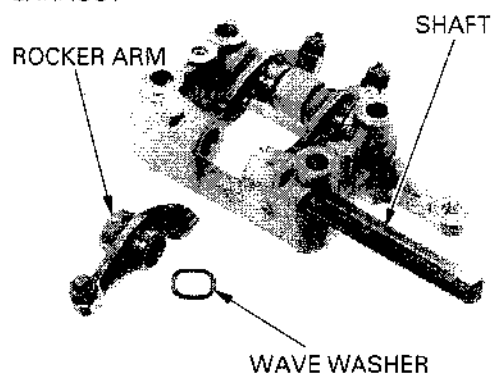

Remove the intake rocker arm shaft, intake rocker arms and wave washers from the camshaft holder.

< INTAKE >

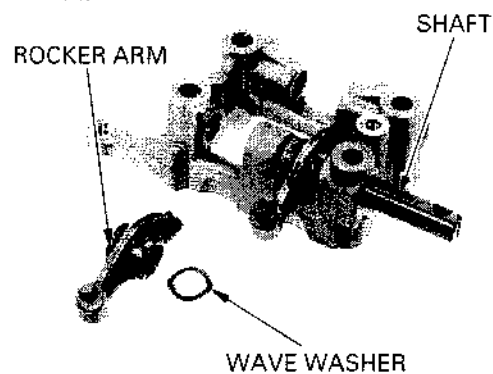

Remove the valve adjuster lock nut and valve adjusting screw.

ADJUSTING SCREW

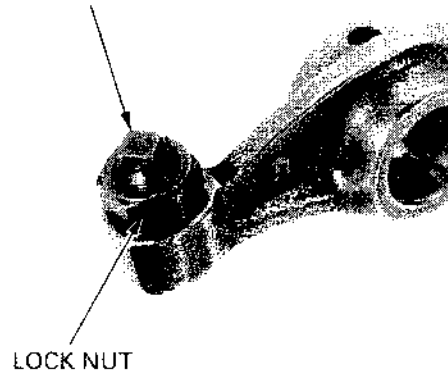

**INSPECTION**

**CAMSHAFT RUNOUT**

Support both ends of the camshaft with V-blocks and check the camshaft runout with a dial indicator. Actual runout is 1/2 the total indicator reading.

**SERVICE LIMIT:** 0.05 mm (0.002 in)

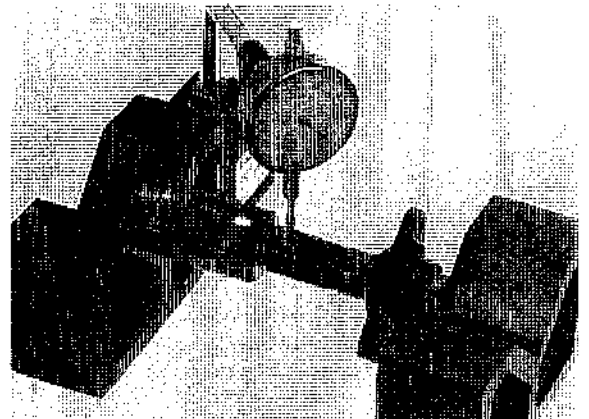

**CAM LOBE HEIGHT**

Inspect the cam lobe surfaces for scoring or evidence of insufficient lubrication. Measure the height of each cam lobe using a micrometer.

**SERVICE LIMITS:**

**IN:** '97-'98: 37.73 mm (1.485 in)

**After '98:** 37.16 mm (1.463 in)

**EX:** '97-'98: 37.75 mm (1.486 in)

**After '98:** 37.58 mm (1.480 in)

**NOTE:**

Inspect the rocker arm if the cam lobe is worn or damaged.

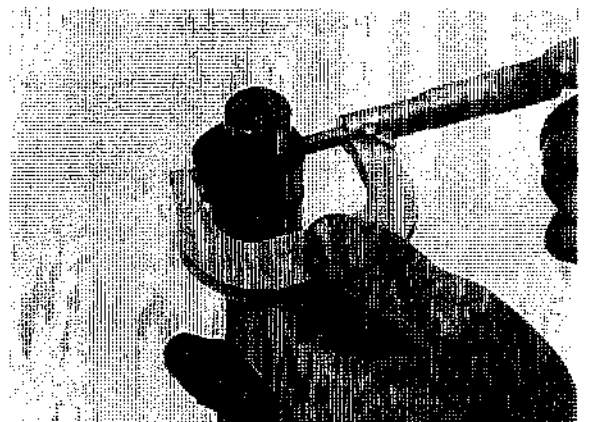

**CAMSHAFT JOURNAL**

Inspect the camshaft journal surfaces for scoring or evidence of insufficient lubrication.

Measure the O.D. of each camshaft journal.

**SERVICE LIMIT:** 21.90 mm (0.862 in)

**NOTE:**

Inspect the oil passages and camshaft holder for wear or damage if the journal surface is worn or damaged.

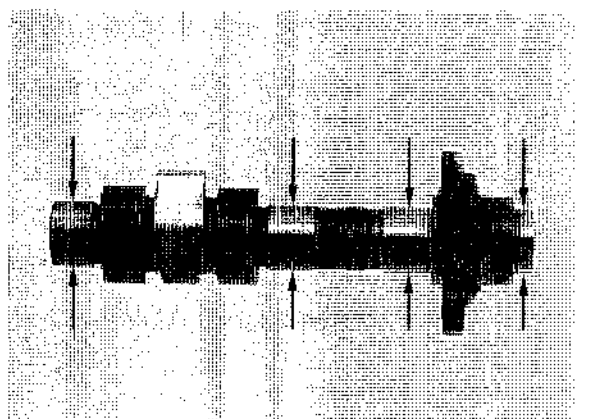
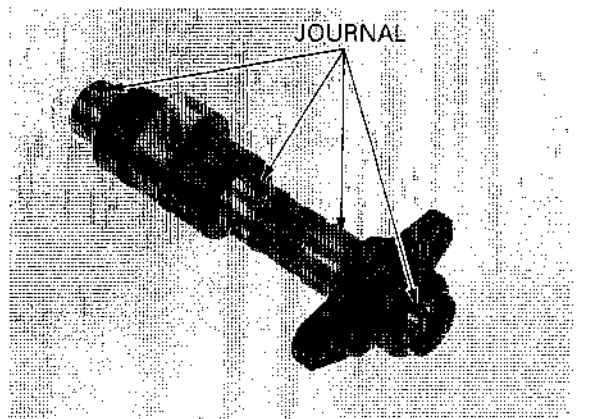

## CYLINDER HEAD/VALVES

### CAMSHAFT OIL CLEARANCE

Clean off any oil from the journals of the camshaft holders, head and camshafts.  
Put the camshaft onto the cylinder head and lay a strip of plastigauge lengthwise on the top of each camshaft journal.

#### NOTE:

- Do not block any oil holes with the plastigauge.
- Do not rotate the camshaft during inspection.

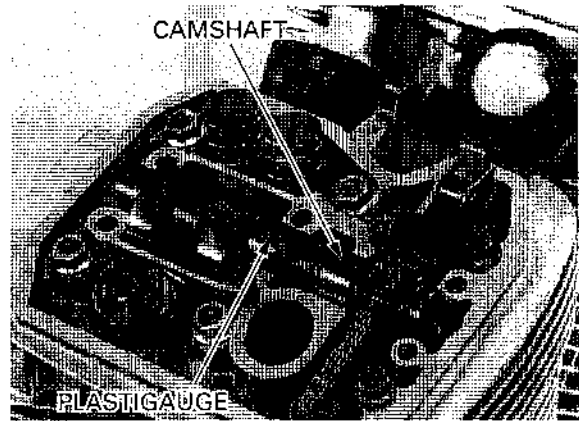

Install the camshaft holder and camshaft end holder.  
Install and tighten the camshaft holder bolts/nuts (8 mm) to the specified torque in 2–3 steps.

**TORQUE:** 23 N·m (2.3 kgf·m , 17 lbf·ft)

Install and tighten the camshaft holder bolts (6 mm) to the specified torque in 2–3 steps.

**TORQUE:** 10 N·m (1.0 kgf·m , 7 lbf·ft)

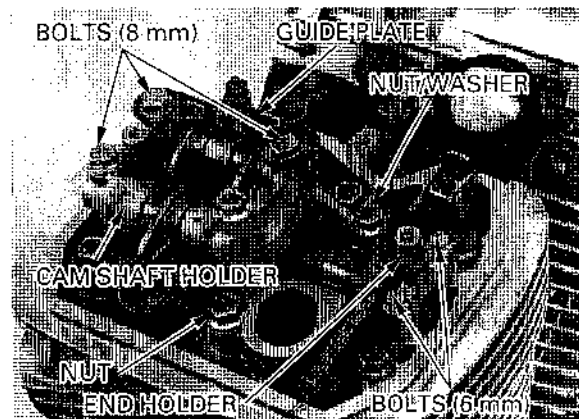

Remove the camshaft holder and measure the width of each plastigauge.  
The widest thickness determines the oil clearance.

**SERVICE LIMIT:** 0.13 mm (0.005 in)

When the service limit is exceeded, replace the camshaft and recheck the oil clearance.

Replace the cylinder head and camshaft holders if the clearance still exceeds the service limit.

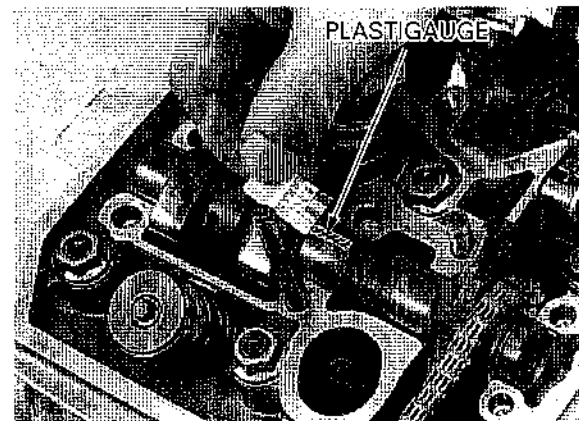

### ROCKER ARM, ROCKER ARM SHAFT

Inspect the sliding surface of the rocker arms for wear or damage where they contact the camshaft, or for clogged oil holes.  
Inspect the contact surface of the valve adjuster screw for wear or damage.

Measure the I.D. of each rocker arm.

**SERVICE LIMIT:** 12.05 mm (0.474 in)

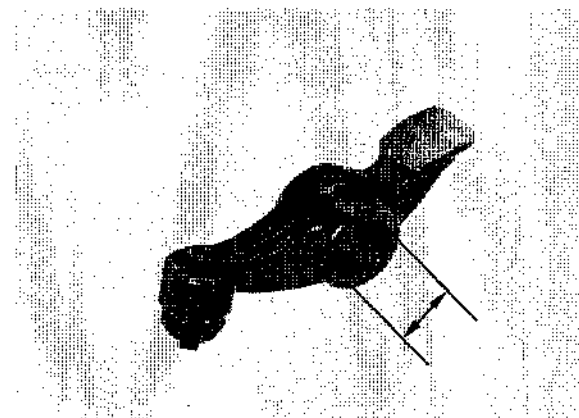



Measure the each rocker arm shaft O.D.

**SERVICE LIMIT:** 11.91 mm (0.469 in)

Inspect the shaft for wear or damage and calculate the shaft to rocker arm clearance.

**SERVICE LIMIT:** 0.07 mm (0.003 in)

Replace the rocker arm and/or shaft if necessary.

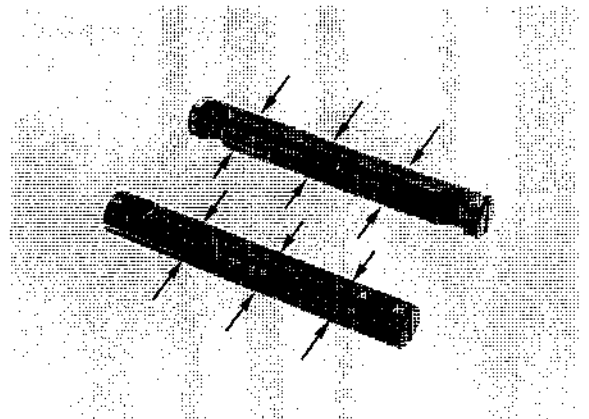

## CYLINDER HEAD REMOVAL

**NOTE:**

- The engine must be removed from the frame before servicing the rear cylinder head.
- The front cylinder head and rear cylinder head cover can be serviced with the engine in the frame.
- The rear cylinder head service uses the same procedure as the front cylinder head.

Remove the engine from the frame (rear cylinder only/Section 7).

Remove the cylinder head cover (page 10-5).

Remove the camshaft (page 10-7).

Remove the cam chain tensioner mounting bolts and sealing washers.

Remove the cam chain tensioner.

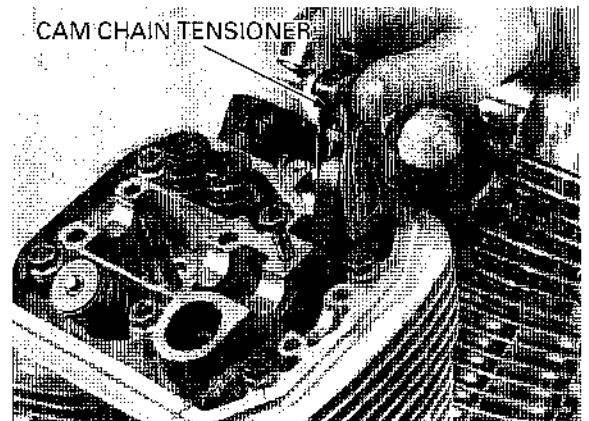

*Loosen the bolts and nuts in a crisscross pattern in several times.*

Remove the following cylinder head bolts and nuts:

- 8 mm bolts/washers
- 6 mm bolt
- 10 mm nuts/washers

*Be careful not to damage the mating surfaces when removing the cylinder head.*

Remove the cylinder head.

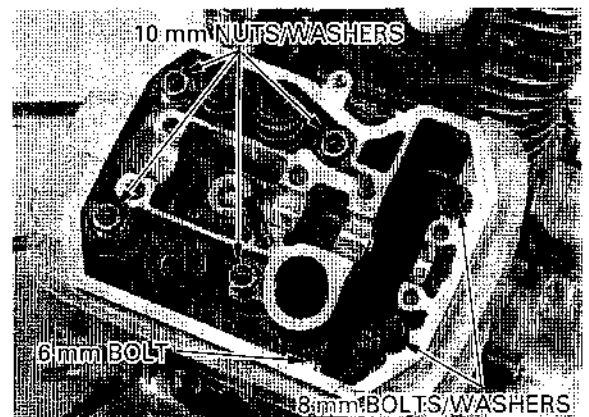

## CYLINDER HEAD/VALVES

Remove the gasket and dowel pins.

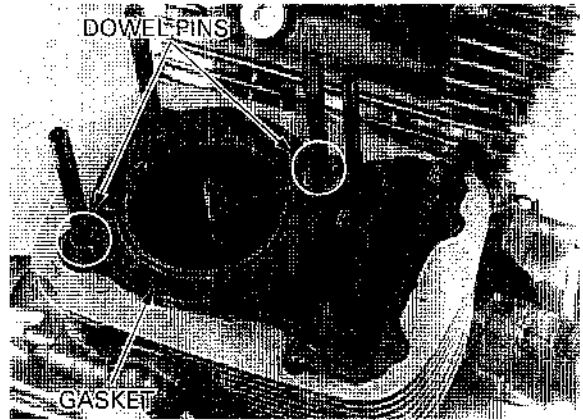

Remove the cam chain guide.

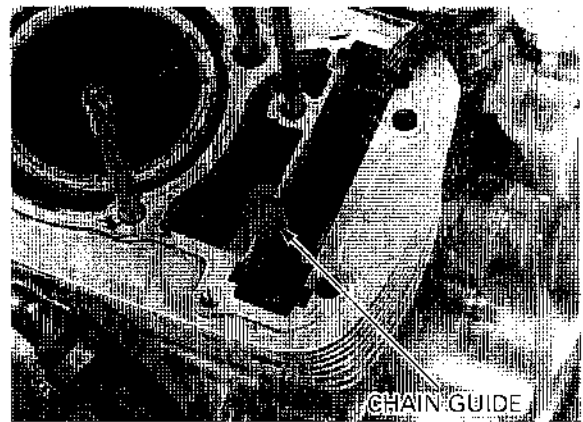

'97-'98: Loosen the screw and remove the carburetor insulator.

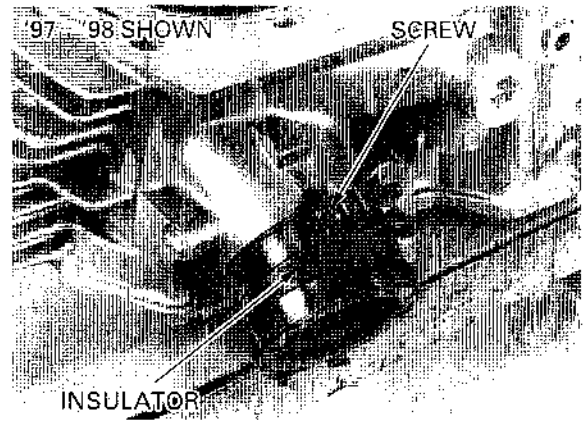

## CYLINDER HEAD DISASSEMBLY

*Mark all parts during disassembly so they can be placed back in their original position.*

Install the valve spring compressor onto the valve and compress the valve spring.

**TOOL:**

**Valve spring compressor** 07757-0010000 or 07957-3290001

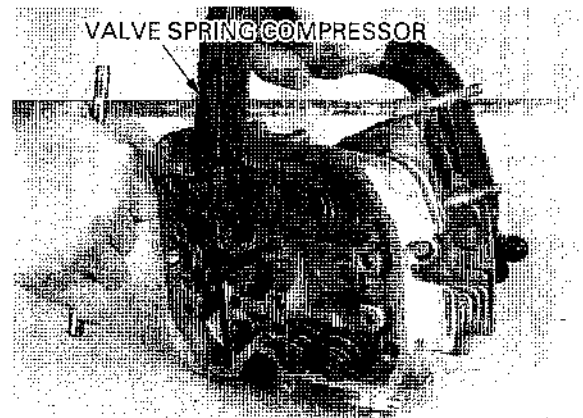

**CAUTION:**

*Compressing the valve springs more than necessary will cause loss of valve spring tension.*

Remove the valve cotters and valve spring compressor, then remove the retainers, springs and valves.  
Remove the stem seals and spring seats.

**NOTE:**

Do not reuse a removed stem seals.

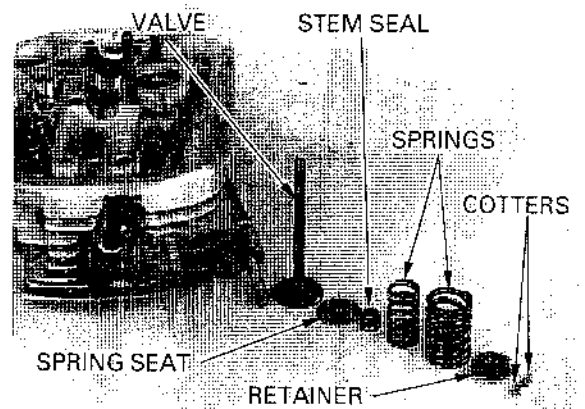

Remove carbon deposits from the combustion chamber and clean off the head gasket surface.

**CAUTION:**

*Avoid damaging the gasket and valve seat surface.*

Check the spark plug hole and valve areas for cracks.

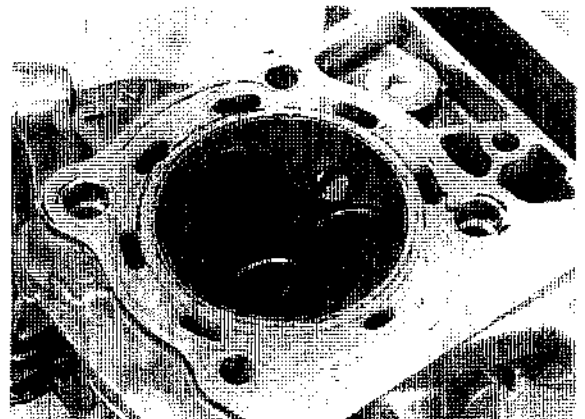

**INSPECTION**

**CYLINDER HEAD**

Check the cylinder head for warpage with a straight edge and feeler gauge.

**SERVICE LIMIT:** 0.10 mm (0.004 in)

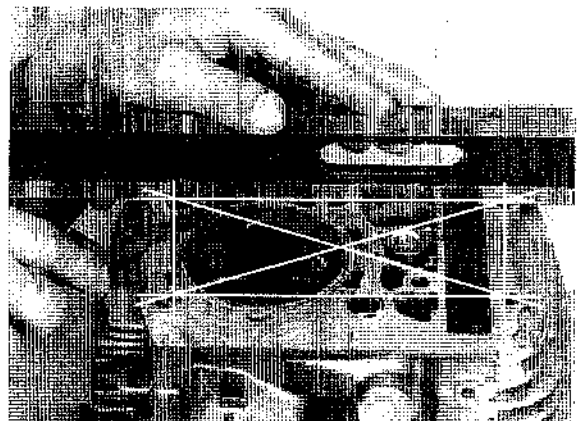

**VALVE SPRING**

Check the valve spring for fatigue or damage. Measure the free length of inner and outer valve springs.

**SERVICE LIMIT:**

- Inner (IN): 36.47 mm (1.436 in)
- (EX): 37.51 mm (1.477 in)
- Outer (IN): 40.58 mm (1.598 in)
- (EX): 41.25 mm (1.624 in)

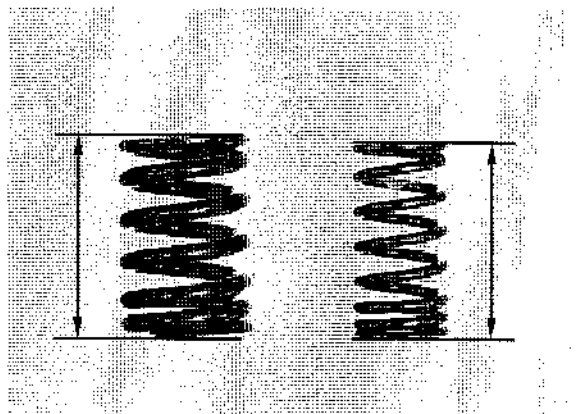



### CAM CHAIN GUIDE

Check the cam chain guide for wear or damage.  
Replace the cam chain guide if necessary.

CHAIN GUIDE



### CAM CHAIN TENSIONER

Check the cam chain tensioner for wear or damage.  
Replace the cam chain tensioner if necessary.

CHAIN TENSIONER

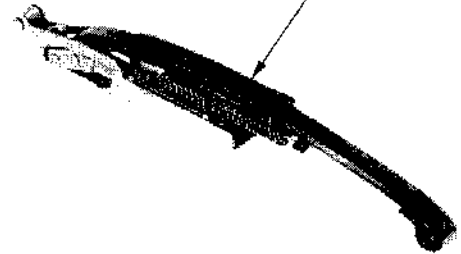

## VALVE GUIDE REPLACEMENT

### NOTE:

---

Refinish the valve seats whenever the valve guides are replaced to prevent uneven seating.

---

Chill the valve guides in the freezer section of refrigerator for about an hour.

### **▲WARNING**

---

*Wear insulated gloves to avoid burns when handling the heated cylinder head.*

---

Heat the cylinder head to 130–140 °C (275–290 °F) with a hot plate or oven. Do not heat the cylinder head beyond 150 °C (300 °F). Use temperature indicator sticks, available from welding supply stores, to be sure the cylinder head is heated to proper temperature.

### CAUTION:

---

*Using a torch to heat the cylinder head may cause warping.*

---

## CYLINDER HEAD/VALVES

Support the cylinder head and drive out the old guides from the combustion chamber side of the cylinder head.

### TOOLS:

#### Valve guide driver

5.5 mm (IN)	07742-0010100
6.6 mm (EX)	07742-0010200 Not available in U.S.A. or 07942-6570100

### CAUTION:

*Be careful not to damage the cylinder head.*

Drive the new guides in from the camshaft side of the cylinder head to the valve guide height while the cylinder head is still heated.

### TOOLS:

#### Valve guide driver

5.5 mm (IN)	07742-0010100
6.6 mm (EX)	07742-0010200 Not available in U.S.A. or 07942-6570100

**NEW**

#### Attachment

5.5 mm (IN)	07943-MF50100
6.6 mm (EX)	07943-MF50200

### VALVE GUIDE PROJECTION:

IN:	19.4	19.6 mm (0.76 - 0.77 in)
EX:	17.9	18.1 mm (0.70 - 0.71 in)

Let the cylinder head cool to room temperature, then ream the new valve guides.

### TOOLS:

#### Valve guide reamer

IN:	07984-2000001 or 07984-200000D
EX:	07984-ZE20001 or 07984-ZE2000D

### NOTE

- Take care not to tilt or lean the reamer in the guide while reaming. Otherwise, the valves will be installed slanted, causing oil leaks from the stem seal and improper valve seat contact. If this occurs, valve seat refacing cannot be performed.
- Insert the reamer from the combustion chamber side of the head and always rotate the reamer clockwise.

Clean the cylinder head thoroughly to remove any metal particles after reaming and refacing the valve seat.

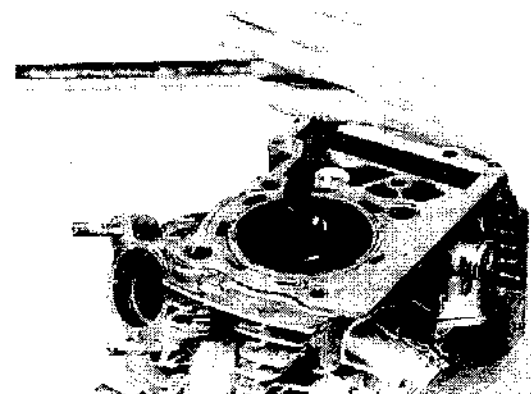
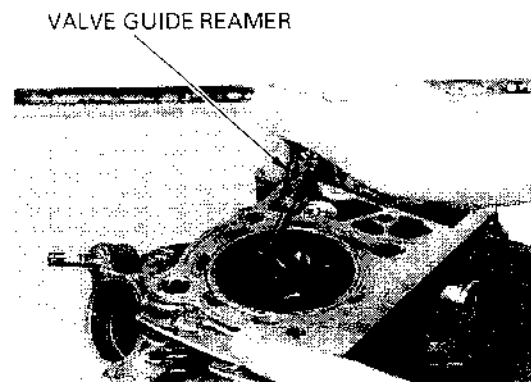
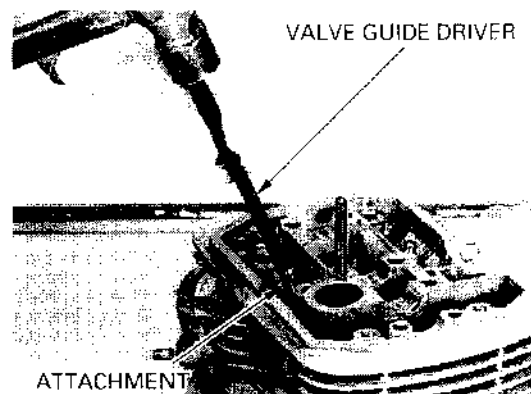
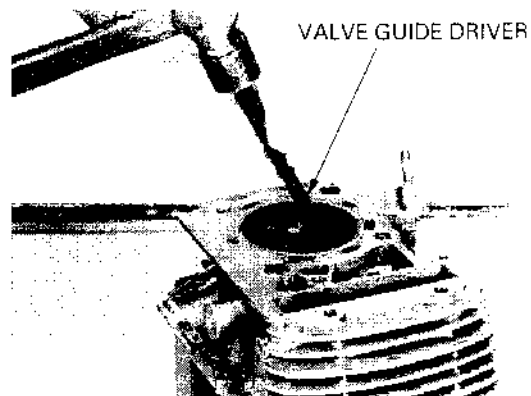

## VALVE SEAT INSPECTION/REFACING

### INSPECTION

Clean all intake and exhaust valves thoroughly to remove carbon deposits.

Apply a light coating of Prussian Blue to each valve face.

Tap the valve against the valve seat several times using a hand-lapping tool, without rotating valve, to make a clear pattern.

Remove the valve and inspect the valve seat face.

#### NOTE:

The valve cannot be ground. If the valve face is burned or badly worn or if it contacts the seat unevenly, replace the valve.

Inspect the valve seat face for:

- Uneven seat width:
  - Bent or collapsed valve stem;
    - Replace the valve and reface the valve seat.
- Damaged face:
  - Replace the valve and reface the valve seat.
- Contact area (too high or too low area):
  - Reface the valve seat.

Inspect the width of the valve seat.

The valve seat contact width should be within the specified dimension and uniform all around the circumference.

**STANDARD:** 0.90 – 1.10 mm (0.035 – 0.043 in)

**SERVICE LIMIT:** 1.5 mm (0.06 in)

If valve seat width is not within specification, reface the valve seat.

### VALVE SEAT REFACING

#### NOTE:

- Follow the refacer manufacture's operating instruction.
- Reface the valve seat whenever the valve guide has been replaced.
- Be careful not to grind the seat more than necessary.

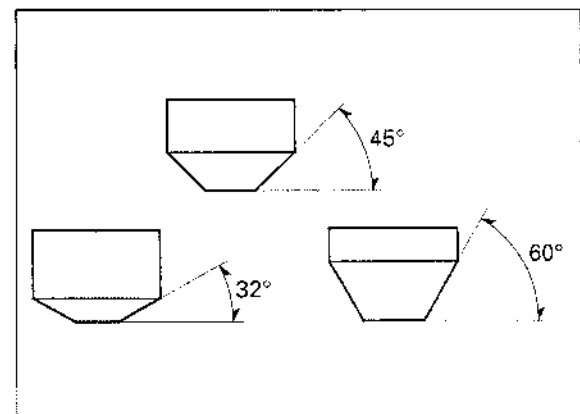
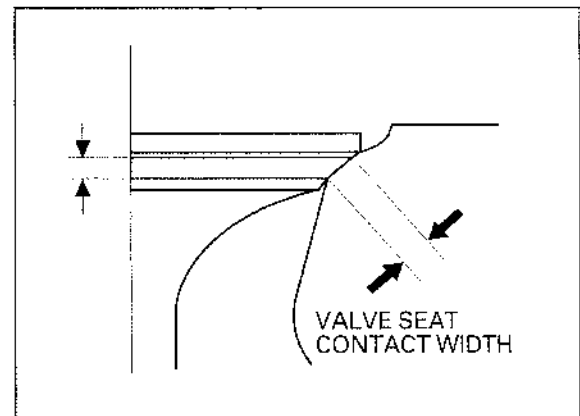
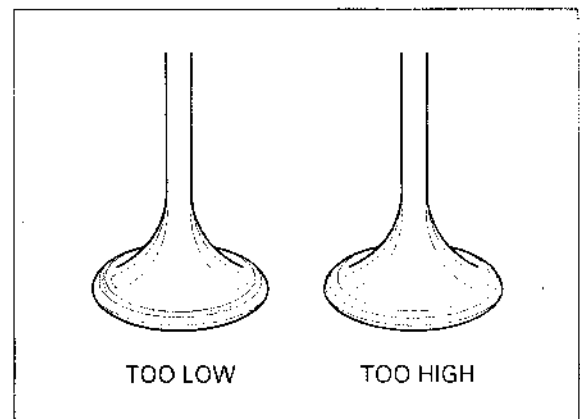
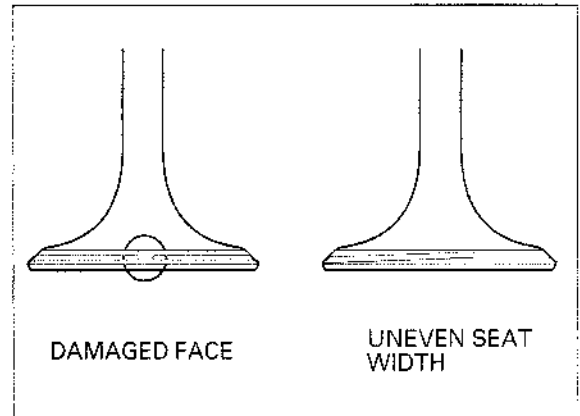

## CYLINDER HEAD/VALVES

If the contact area is too high on the valve, the seat must be lowered using a 32° flat cutter.

If the contact area is too low on the valve, the seat must be raised using a 60° inner cutter. Refinish the seat to specifications, using a 45° finish cutter.

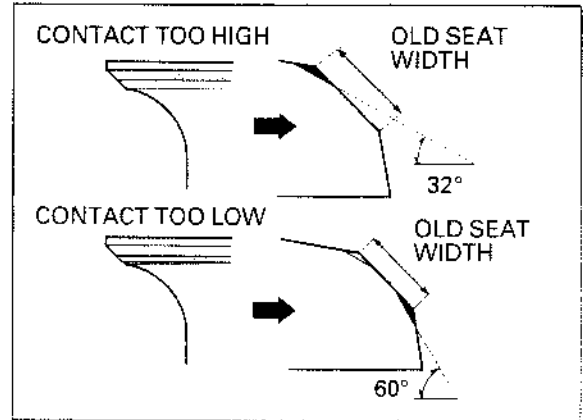

Using a 45° cutter, remove any roughness or irregularities from the seat.

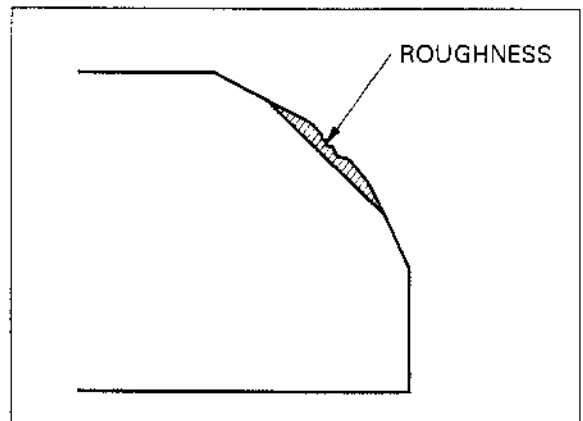

Using a 32° cutter, remove 1/4 of the existing valve seat material.

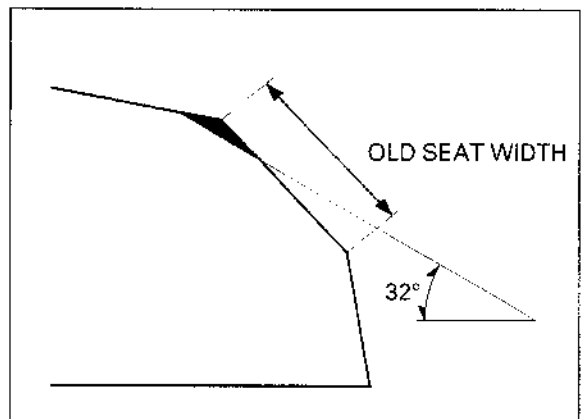

Using a 60° cutter, remove the bottom 1/4 of the old seat.

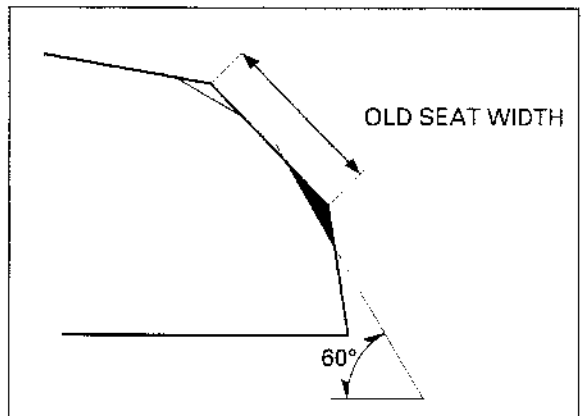



Using a 45° cutter, cut the seat to the proper width. Make sure that all pitting and irregularities are removed.

**CAUTION:**

- *Excessive lapping pressure may deform or damage the seat.*
- *Change the angle of lapping tool frequently to prevent uneven seat wear.*
- *Lapping compound can cause damage if it enters between the valve stem and guide.*

After cutting the seat, apply lapping compound to the valve face, and lap the valve using light pressure.

After lapping, wash any residual compound off the cylinder head and valve.

Recheck the seat contact after lapping.

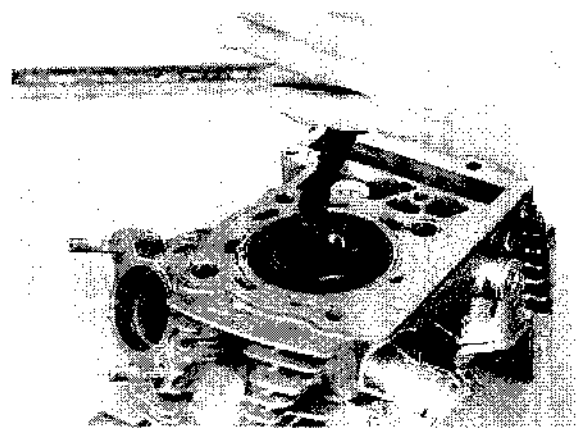
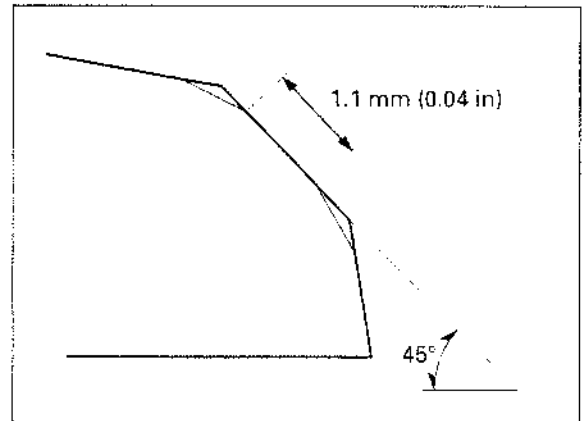

## CYLINDER HEAD ASSEMBLY

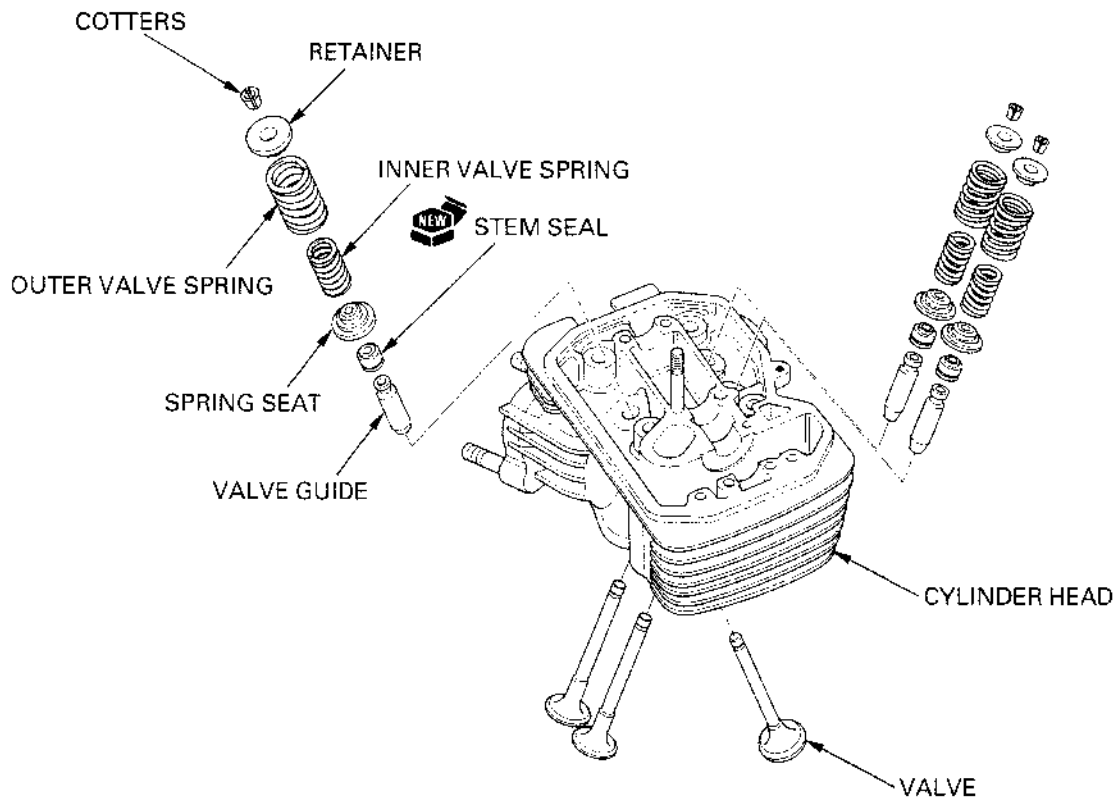

## CYLINDER HEAD/VALVES

Install the spring seats and new stem seals.  
Lubricate each valve stems and valve guide inner surfaces with molybdenum oil solution.

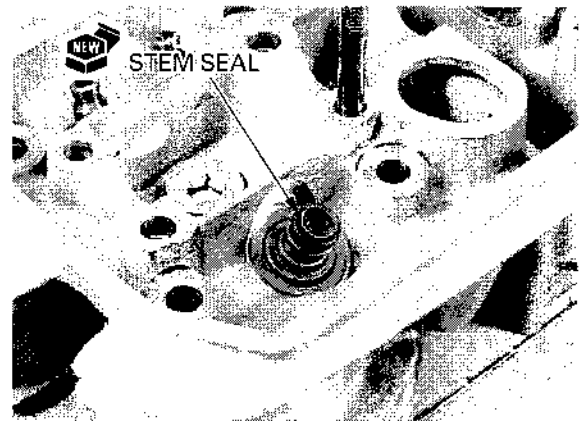

Install the valves into the valve guides.

### NOTE:

To avoid damage to the stem seal, turn the valve slowly when valve installing.

Install the inner, outer valve springs with tightly wound coils side facing the combustion chamber.

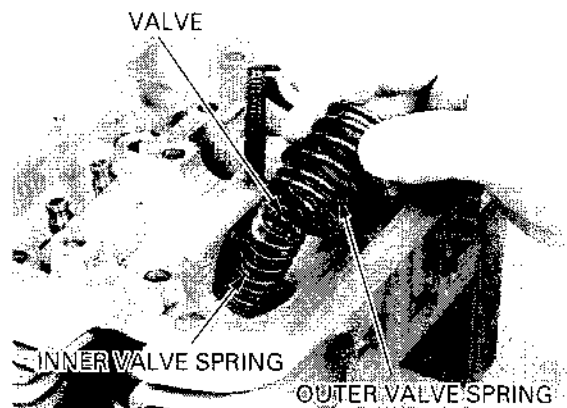

Install the retainers.  
Install the valve spring compressor onto the valve and compress the valve springs.

### TOOL:

Valve spring compressor 07757-0010000 or  
07957-3290001

### CAUTION:

*Compressing the valve springs more than necessary will cause loss of valve spring tension.*

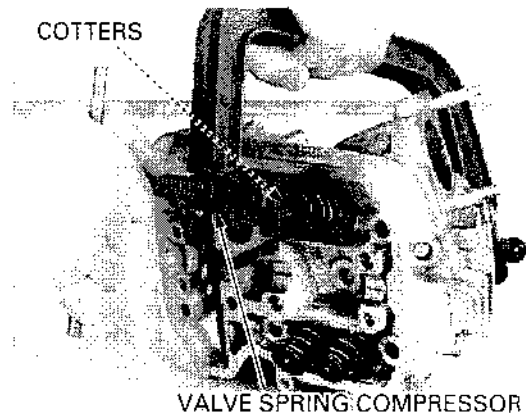

*To ease installation of the cotters, grease them first.*

Install the valve cotters.

### NOTE:

Support the cylinder head so that the valve heads will not contact anything that causes damage.

Set the cotters firmly using two soft hammers as shown. Hold one hammer on the valve stem and gently tap it with the other hammer.

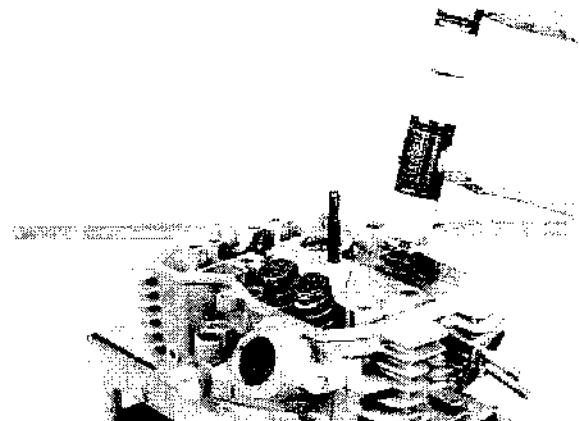

## CYLINDER HEAD INSTALLATION

**NOTE:**

- The rear cylinder head uses the same service procedure as the front cylinder head.
- Be careful not to damage the mating surfaces when cleaning the cylinder mating surface.
- When cleaning the cylinder mating surface, place the shop towel over the cylinder opening to prevent dust or dirt from entering the engine.

Clean any gasket material from the cylinder mating surfaces.

Install the cam chain guide aligning its tab with the groove on the cylinder. Make sure that the end of the guide is inserted into place in the crankcase.

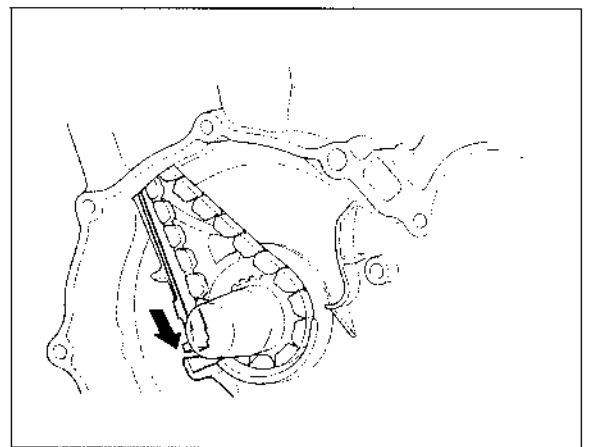
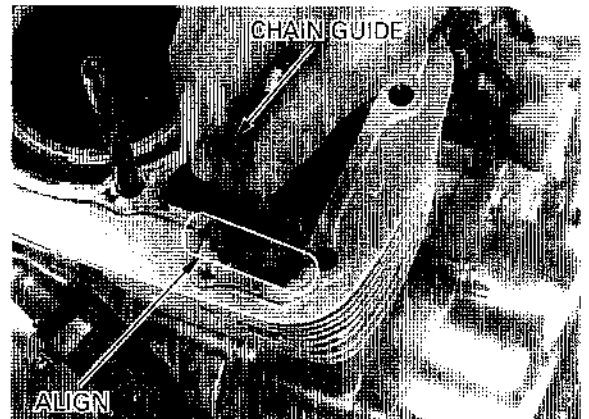

Install the dowel pins and new gasket.

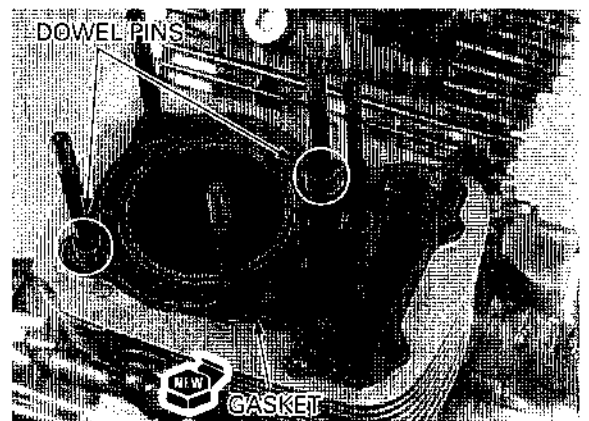

*49 state, Canada ('97-'98) type:* Install the insulator, aligning the boss on the cylinder head with the slot in the insulator as shown.

Install the insulator bands and tighten the screws securely.

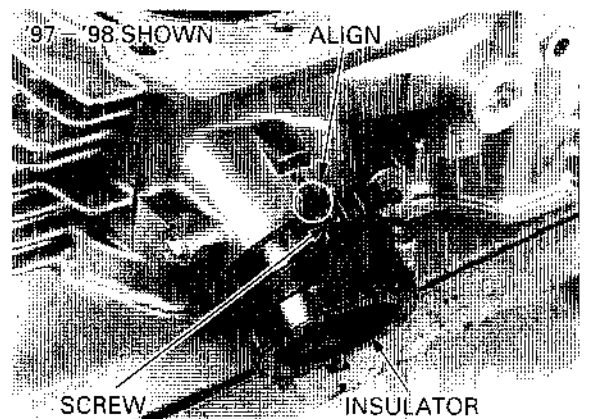

## CYLINDER HEAD/VALVES

*California ('97-'98) type:* Install the insulator bands aligning the pins on the insulator bands with the slots on the insulators as shown.

Tighten the band screws securely.

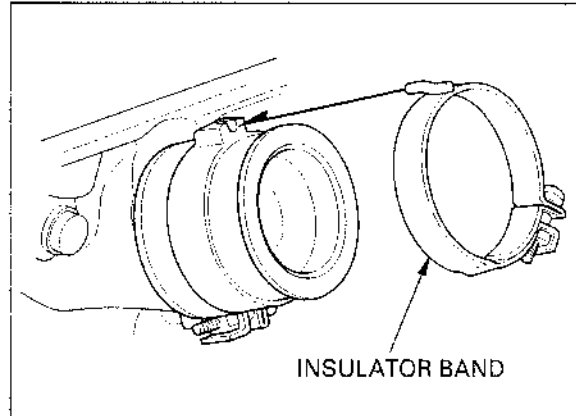

Install the cylinder head to the cylinder.

### NOTE:

The cylinder heads are identified by marks on its camshaft side.

"F": Front cylinder head

"R": Rear cylinder head

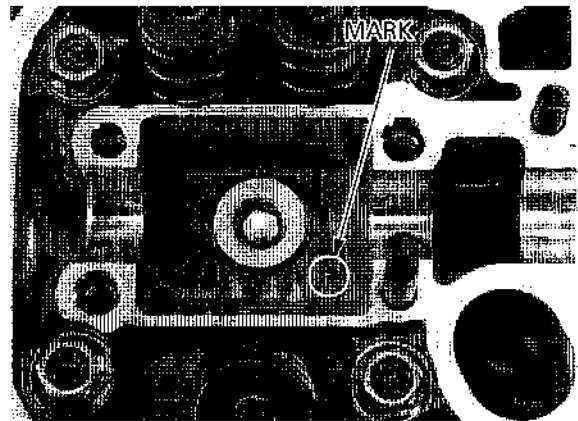

Apply oil to the cylinder head 10 mm nut threads and flange surfaces.

Install and tighten the cylinder head bolts and nuts to the specified torque:

### TORQUE:

**10 mm nut:** 47 N·m (4.8 kgf·m , 35 lbf·ft)

**8 mm bolt:** 23 N·m (2.3 kgf·m , 17 lbf·ft)

**6 mm bolt:** 12 N·m (1.2 kgf·m , 9 lbf·ft)

### NOTE:

- Tighten all hand-tight, then torque the big fasteners before little fasteners.
- Tighten the bolts and nuts in a crisscross pattern in several times.

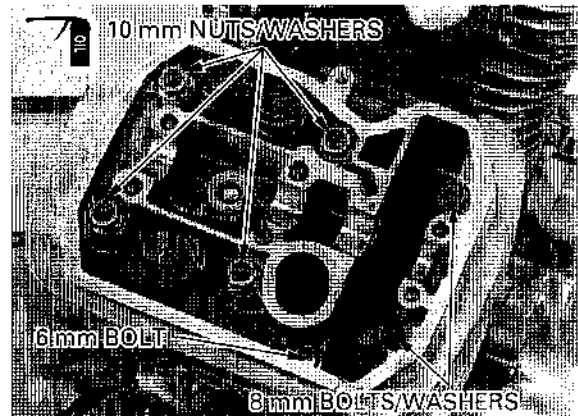

Install the cam chain tensioner by aligning its end with the groove on the crankcase.

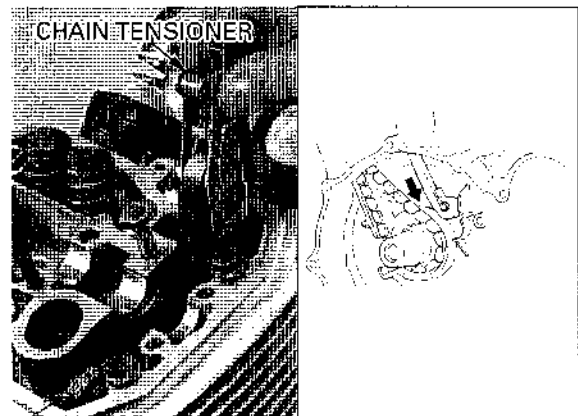

Install the new sealing washers.  
 Clean and apply a locking agent to the cam chain tensioner bolt threads.  
 Install and tighten the cam chain tensioner mounting bolt to the specified torque.

**TORQUE:** 10 N·m (1.0 kgf·m , 7 lbf·ft)

Install the engine to the frame (rear cylinder only/ Section 7).  
 Install the camshaft (see below).  
 Install the cylinder head cover (page 10-31).



## CAMSHAFT INSTALLATION

### CAMSHAFT HOLDER ASSEMBLY

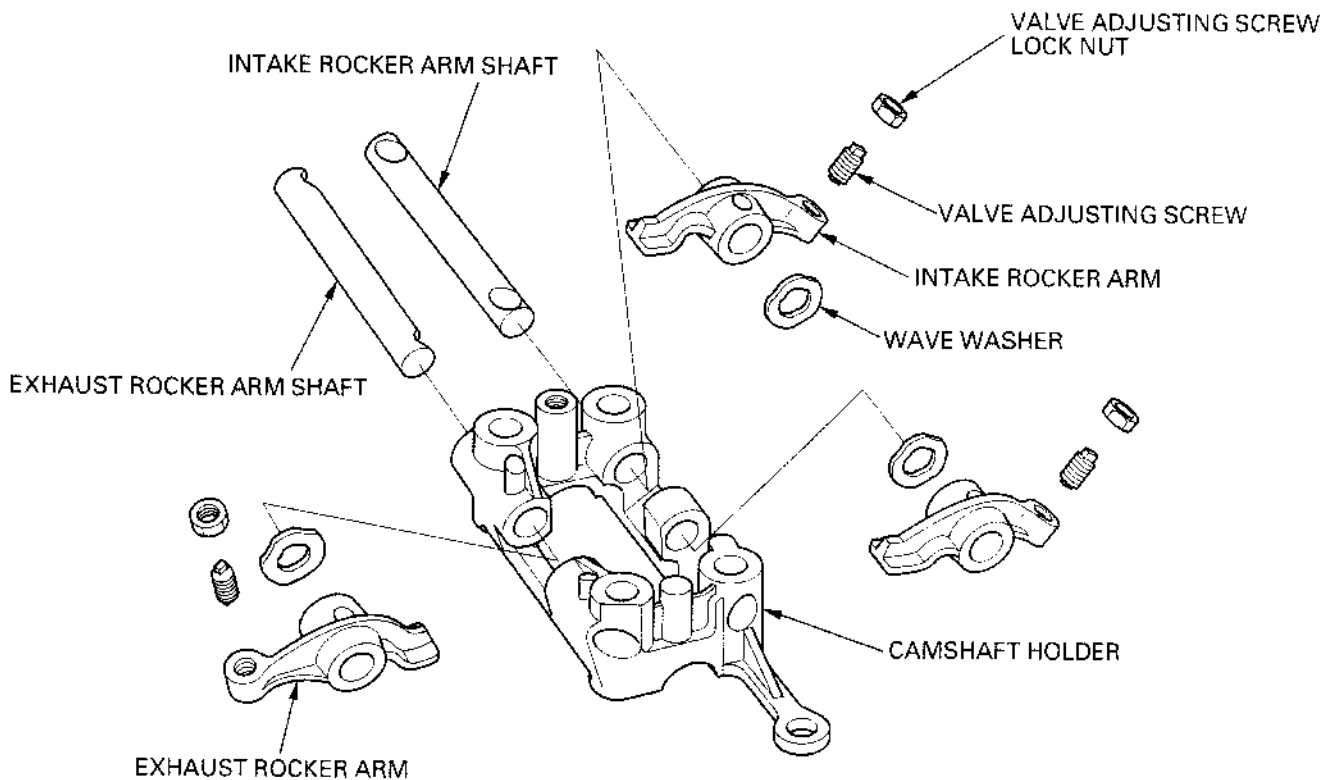

**NOTE:**

Camshaft lubricating oil is fed through oil passages in the cylinder head and camshaft holder. Clean the oil passages before assembling the cylinder head and camshaft holder.

Lubricate each rocker arm shaft outer sliding surfaces with molybdenum oil solution.

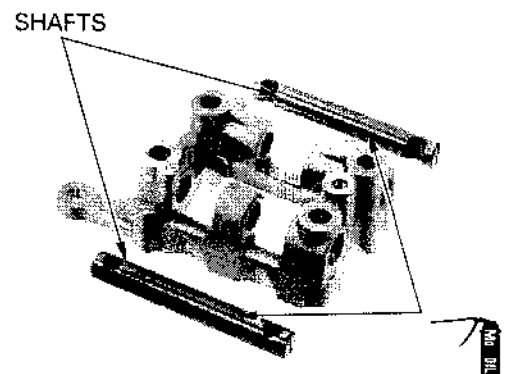

## CYLINDER HEAD/VALVES

Install the valve adjusting screw and lock nut.

ADJUSTING SCREW

LOCK NUT

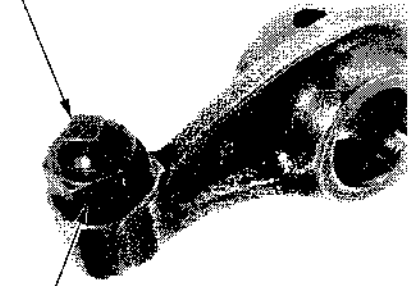

### NOTE:

- The exhaust rocker arm has larger slipper face than the intake rocker arm.
- The intake rocker arm shaft has two holes on each end.
- The exhaust rocker arm shaft has two grooves on each end.

Install the wave washer, intake rocker arm and intake rocker arm shaft to the camshaft holder.

<INTAKE>

SHAFT

ROCKER ARM

WAVE WASHER

<EXHAUST>

"△" MARK

ROCKER ARM

WAVE WASHER

SHAFT

Install the wave washer to the "△" mark side on the camshaft holder.

Install the exhaust rocker arm and exhaust rocker arm shaft to the camshaft holder.

ROCKER ARM

ALIGN

"△" MARK

WAVE WASHERS

ALIGN

Position the grooves and holes in the rocker arm shafts vertically, aligning the bolt holes of the holder.

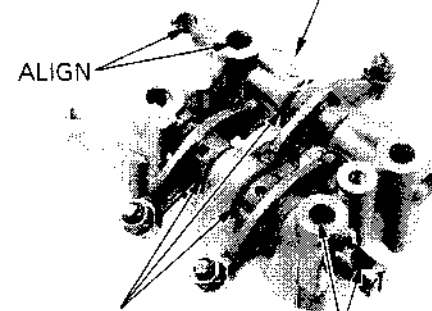

**CAMSHAFT INSTALLATION**

**NOTE:**

- The camshafts are identified by marks on the their flanges:  
 "F": Front cylinder camshaft  
 "R": Rear cylinder camshaft  
 "Index notch" : TDC (Top Dead Center) mark
- If both (front and rear) camshafts are removed, install the front cylinder camshaft first, then install the rear cylinder camshaft.
- If the rear cylinder head was not serviced, remove the rear cylinder head cover to check the camshaft position.
- If the front cylinder head was not serviced, remove the front cylinder head cover to check the camshaft position.

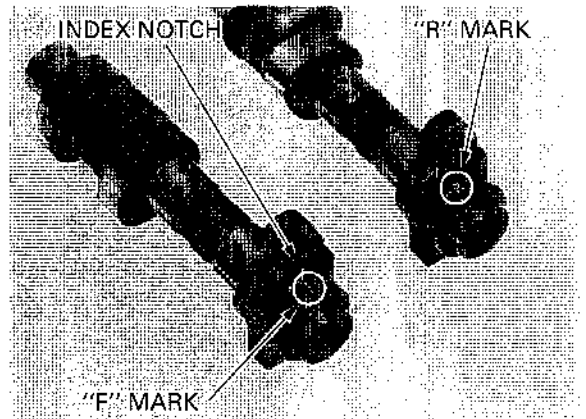

**VALVE TIMING**

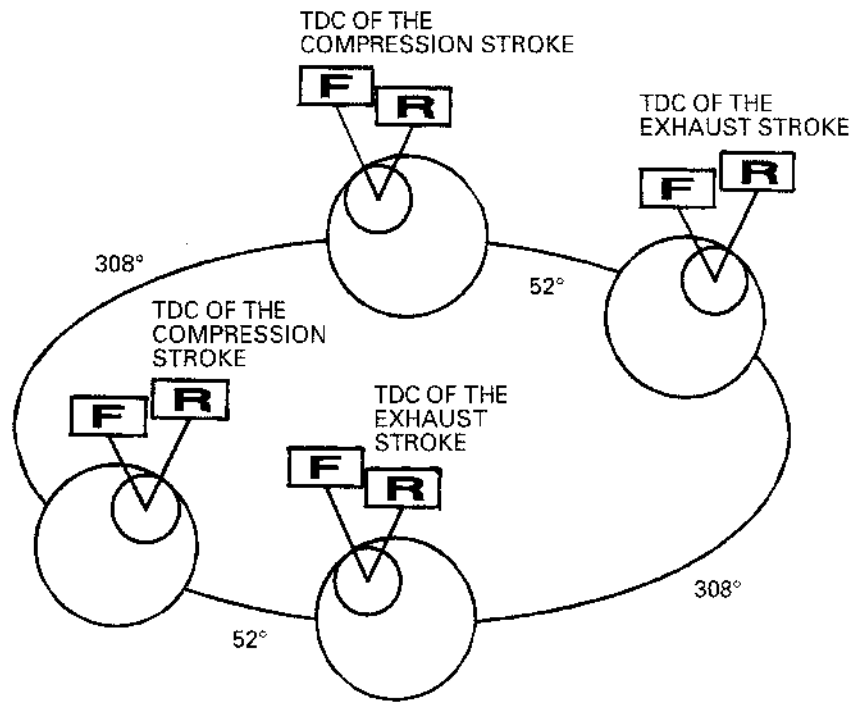

**CAMSHAFT SERVICE FOR BOTH CYLINDER**

Remove the timing hole cap.  
 Turn the crankshaft counterclockwise and align the "FT" mark on the flywheel with the index mark on the left crankcase cover, then check the front cylinder piston is "TDC (Top Dead Center)".  
 Install the front cylinder camshaft (page 10-29).

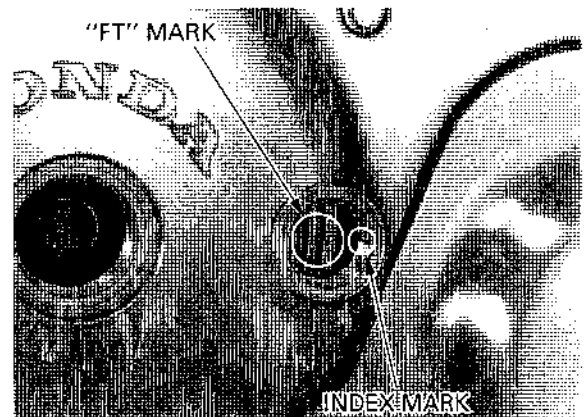

## CYLINDER HEAD/VALVES

Then turn the crankshaft counterclockwise  $308^\circ$  and align the "RT" mark on the flywheel with the index mark on the left crankcase cover, then install the rear camshaft (see after page).

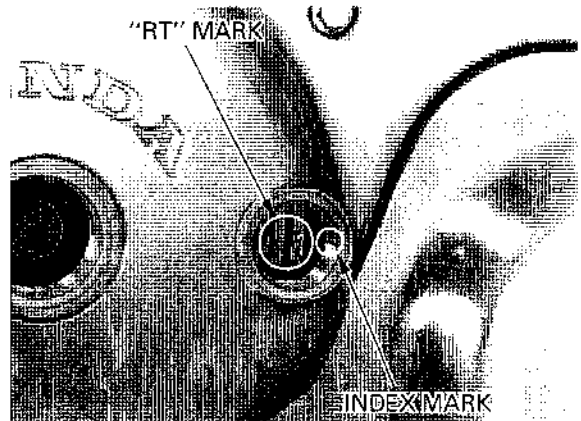

### REAR CYLINDER CAMSHAFT SERVICE ONLY (FRONT CYLINDER CAMSHAFT WAS NOT SERVICED)

If the front cylinder head was not serviced, remove the front cylinder head cover (page 10-5) and check the camshaft position as follows:

Remove the front cylinder head camshaft end holder (page 10-7).

Remove the timing hole cap and crankshaft hole cap.

Turn the crankshaft counterclockwise and align the "FT" mark on the flywheel with the index mark on the left crankcase cover, then check that the camshaft "TDC (Top Dead Center)" mark is facing up.

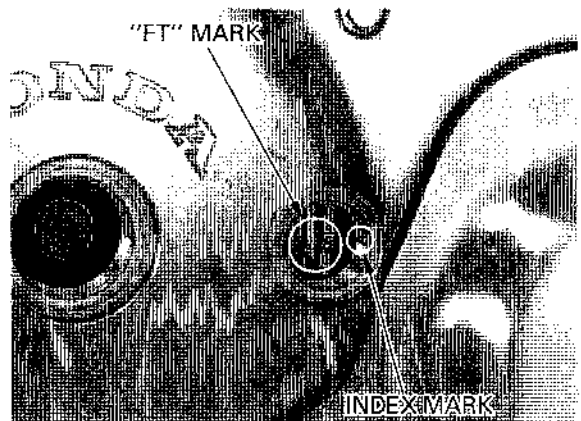

If the "TDC (Top Dead Center)" mark is facing up, turn the crankshaft counterclockwise  $308^\circ$  and align the "RT" mark on the flywheel with the index mark on the left crankcase cover, then install the rear camshaft (see after page).

If the "TDC (Top Dead Center)" mark is facing down, turn the crankshaft counterclockwise  $668^\circ$  ( $360^\circ + 308^\circ$ ) and align the "RT" mark on the flywheel with the index mark on the left crankcase cover, then install the rear camshaft (see after page).

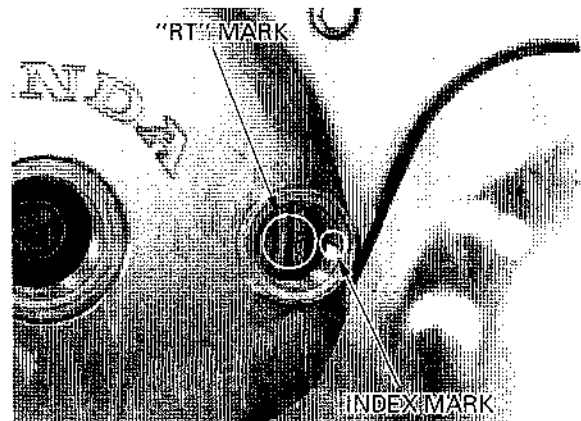

### FRONT CYLINDER CAMSHAFT SERVICE ONLY (REAR CYLINDER CAMSHAFT WAS NOT SERVICED)

If the rear cylinder head was not serviced, remove the rear cylinder head cover (page 10-6) and check the camshaft position as follows:

Remove the front cylinder head camshaft end holder (page 10-7).

Remove the timing hole cap.

Turn the crankshaft counterclockwise and align the "RT" mark on the flywheel with the index mark on the left crankcase cover, then check that the camshaft "TDC (Top Dead Center)" mark is facing up.

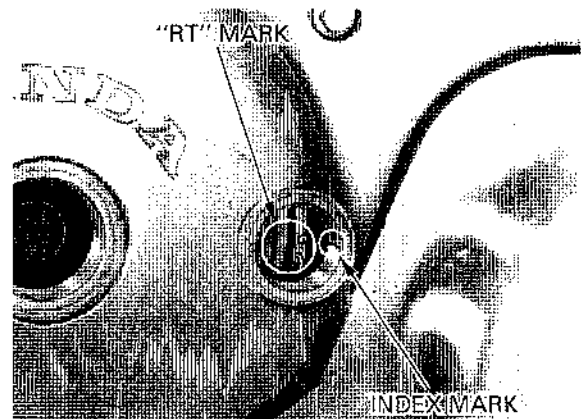



If the "TDC (Top Dead Center)" mark is facing up, turn the crankshaft counterclockwise  $412^{\circ}$  ( $360^{\circ} + 52^{\circ}$ ) and align the "FT" mark on the flywheel with the index mark on the left crankcase cover, then install the front camshaft (page 10-30).

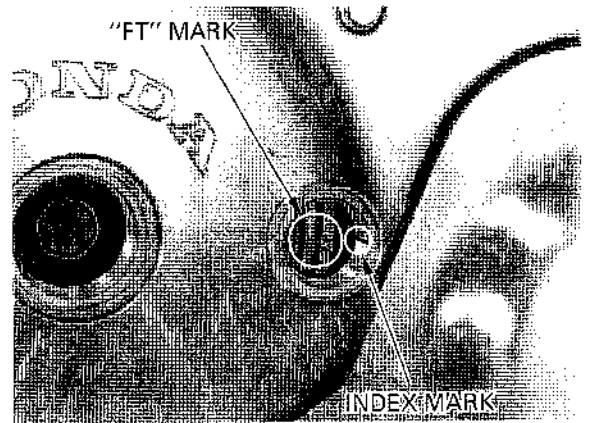

If the "TDC (Top Dead Center)" mark is facing down, turn the crankshaft counterclockwise  $52^{\circ}$  and align the "FT" mark on the flywheel with the index mark on the left crankcase cover, then install the front camshaft (page 10-30).

**CAMSHAFT INSTALLATION**

Remove the timing hole cap. Turn the crankshaft counterclockwise and align the "FT" mark (rear cylinder: "RT" mark) on the flywheel with the index mark on the left crankcase cover.

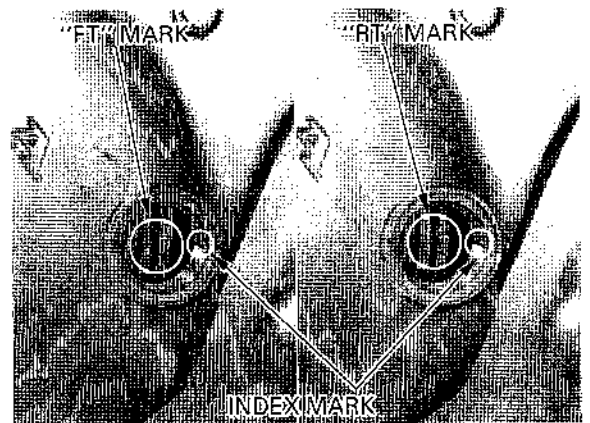

Install the cam sprocket to the cam chain with the "IN" mark facing the inside and align the timing marks (index line) on the cam sprocket and the upper surface of the cylinder head.

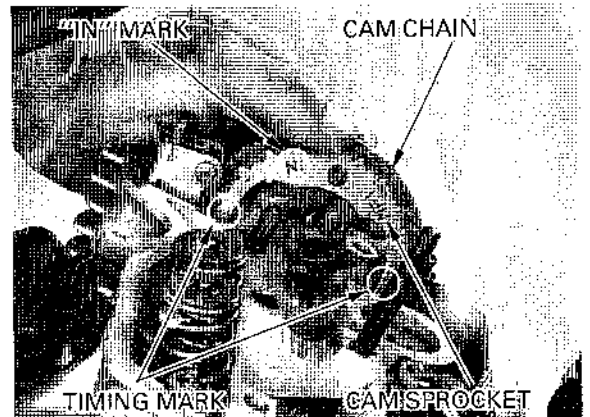

Install the camshaft through the cam chain and cam sprocket with the camshaft "TDC" mark is facing up.

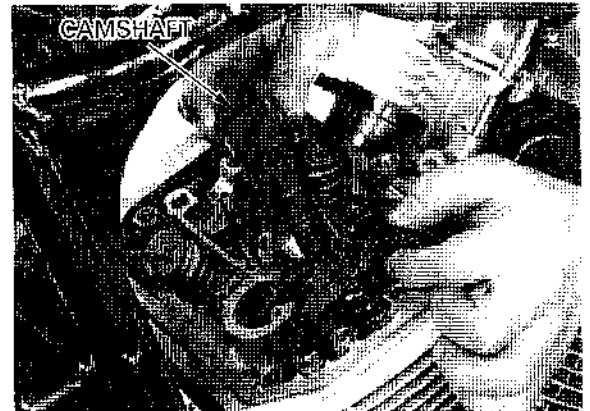

**NOTE:**

The camshafts are identified by marks on the their flanges:

- "F": Front cylinder camshaft
- "R": Rear cylinder camshaft
- "Index notch": TDC (Top Dead Center) mark

## CYLINDER HEAD/VALVES

Install the dowel pins.  
Lubricate each rocker arm slipper surfaces with molybdenum oil solution.

### NOTE:

Before camshaft holder installation, loosen the valve adjusting screw and lock nut fully.

Install the camshaft holder assembly.

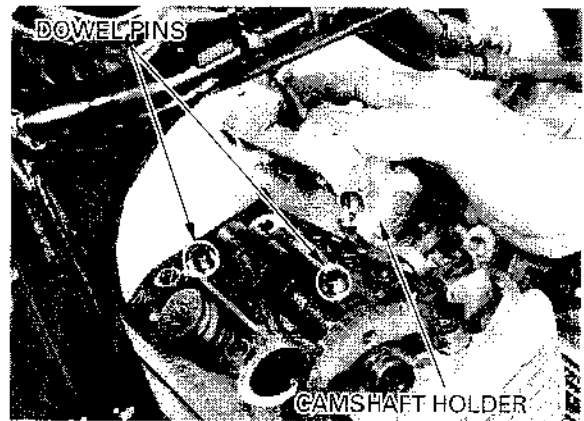

Install the oil guide plate.  
Install the camshaft holder bolts (8 mm), nuts and washer (8 mm).  
Tighten the bolts (8 mm) and nuts (8 mm) to the specified torque.

**TORQUE: 8 mm bolt:** 23 N·m (2.3 kgf·m , 17 lbf·ft)  
**8 mm nut:** 23 N·m (2.3 kgf·m , 17 lbf·ft)

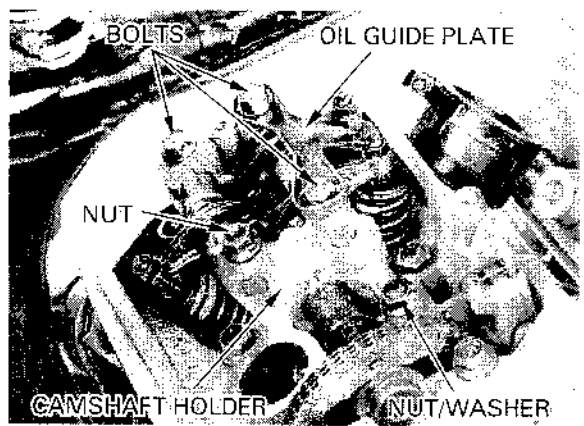

Install the cam sprocket on the camshaft flange and recheck that the timing marks align with the upper surface of the cylinder head.

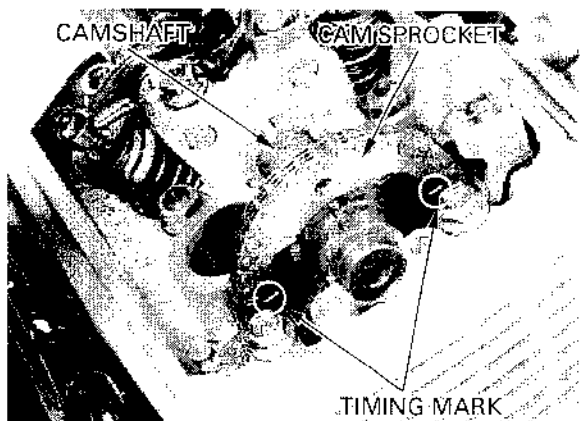

Clean and apply a locking agent to the cam sprocket bolt threads.

### NOTE:

Be careful not to let the cam sprocket bolts fall into the crankcase.

Align the cam sprocket bolt holes in the cam sprocket and camshaft.  
Temporarily install the cam sprocket bolt.  
Turn the crankshaft counterclockwise 360° and tighten other sprocket bolt to the specified torque.

**TORQUE:** 23 N·m (2.3 kgf·m , 17 lbf·ft)

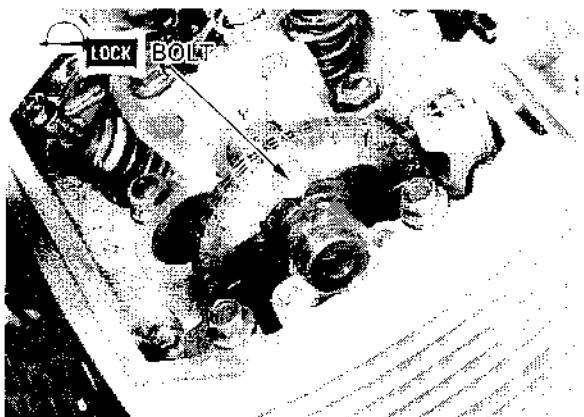

Turn the crankshaft counterclockwise 360° and tighten other sprocket bolt to the specified torque.

Remove the 2 mm pin holding cam chain tensioner wedge A.

**NOTE:**

- Be careful not to let the 2 mm pin fall into the crankcase.
- Do not forget to remove the 2 mm pin before installing the cylinder head cover.

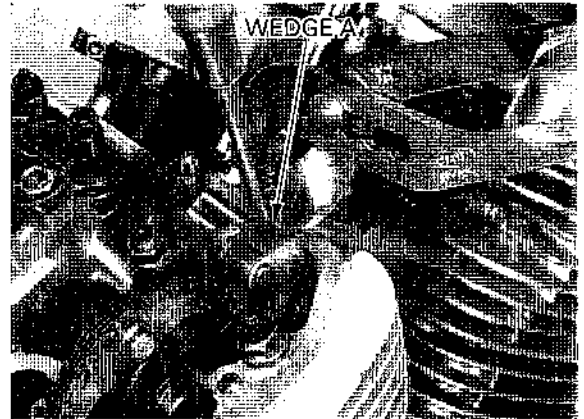

Install the dowel pins.  
Install the camshaft end holder with its flat surface on the holder facing in.

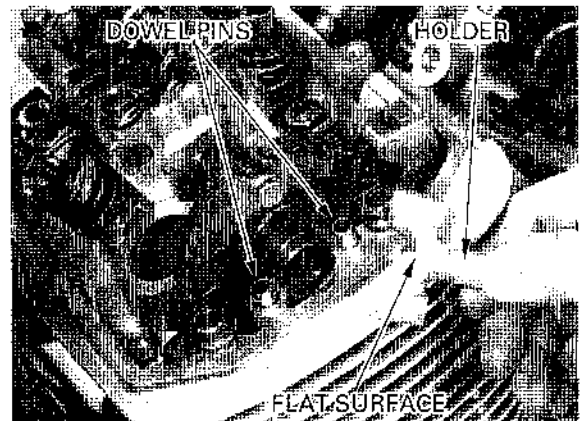

Install and tighten the camshaft end holder bolts to the specified torque.

**TORQUE:** '97 – '98: 9 N·m (0.9 kgf·m, 6.5 lbf·ft)  
After '98: 10 N·m (1.0 kgf·m, 7 lbf·ft)

Adjust the valve clearance (page 3-11).

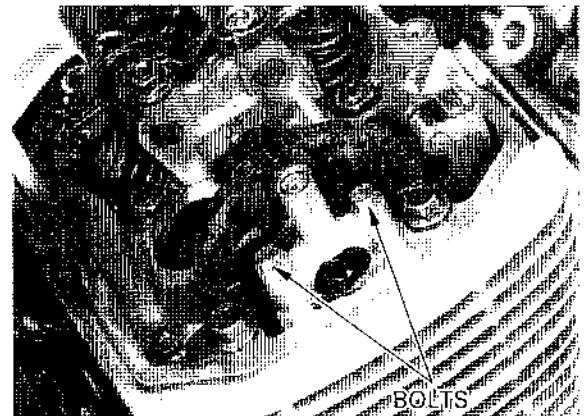

## CYLINDER HEAD COVER INSTALLATION

Fill the oil pockets in the head with the engine oil.

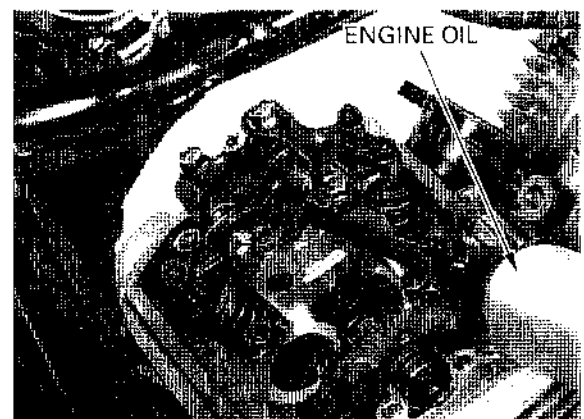

## CYLINDER HEAD/VALVES

Clean the gasket groove of the cylinder head cover. Apply Honda Bond A or equivalent to the gasket groove of the cylinder head cover, then install the new gasket into the groove.



### FRONT

Install the front cylinder head cover to the front cylinder.

Install the rubber seals and washers. Install and tighten the cylinder head cover bolts to the specified torque.

**TORQUE:** 10 N·m (1.0 kgf·m, 7 lbf·ft)



Install the new O-ring to the water pipe with the small diameter side facing the cylinder head. Install the water pipe to the front cylinder head. Install and tighten the bolt securely.

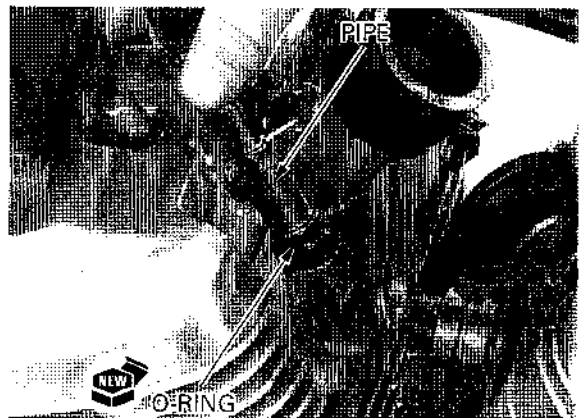

Connect the spark plug caps.  
Install the inlet manifold (After '98: page 7-11).  
Install the carburetors ('97 - '98: page 5-26).  
Install the air cleaner housing (page 5-5).  
Install the fuel tank (page 2-7).  
Install the steering covers (page 2-3).  
Replace the coolant (page 6-6).



### REAR

Install the rear cylinder head cover to the rear cylinder.

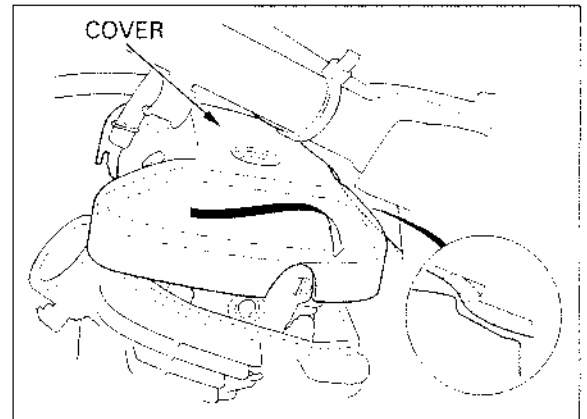

Install the rubber seals and washers.  
Install and tighten the cylinder head cover bolts to the specified torque.

**TORQUE:** 10 N·m (1.0 kgf·m , 7 lbf·ft)

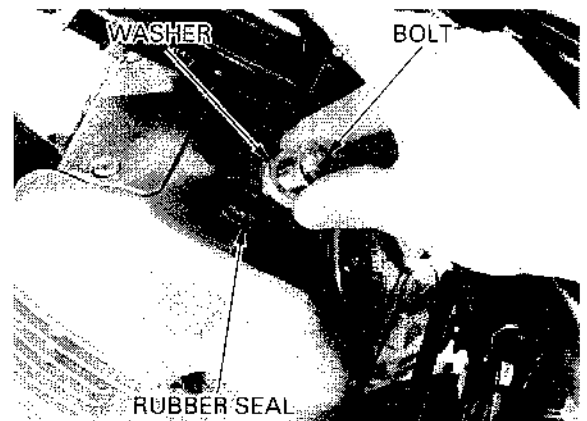

Install the new O-ring to the water pipe with the small diameter side facing the cylinder head.  
Install the water pipe to the rear cylinder head.  
Install and tighten the bolt securely.

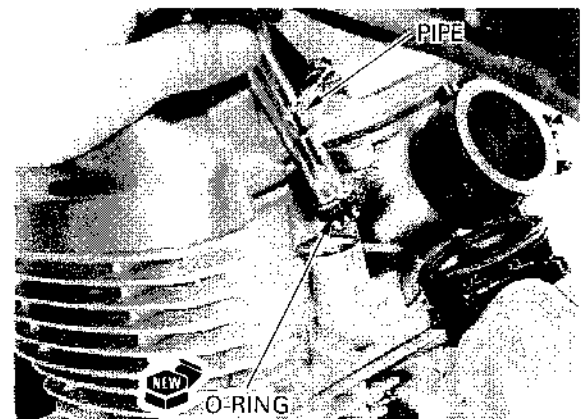

Connect the spark plug caps.



## CYLINDER HEAD/VALVES

---

Install the valve adjusting cover and socket bolt.  
Tighten the socket bolt to the specified torque.

**TORQUE:** 12 N·m (1.2 kgf·m , 9 lbf·ft)

Install the inlet manifold (After '98: page 7-11).  
Install the carburetor(s) ('97 - '98: page 5-26,  
After '98: page 5-27).  
Install the air cleaner housing (page 5-5).  
Install the fuel tank (page 2-7).  
Install the steering covers (page 2-3).  
Replace the coolant (page 6-6).

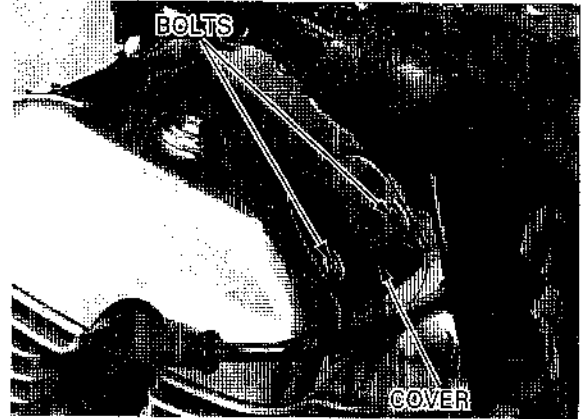

---

**MEMO**

---

CYLINDER/PISTON

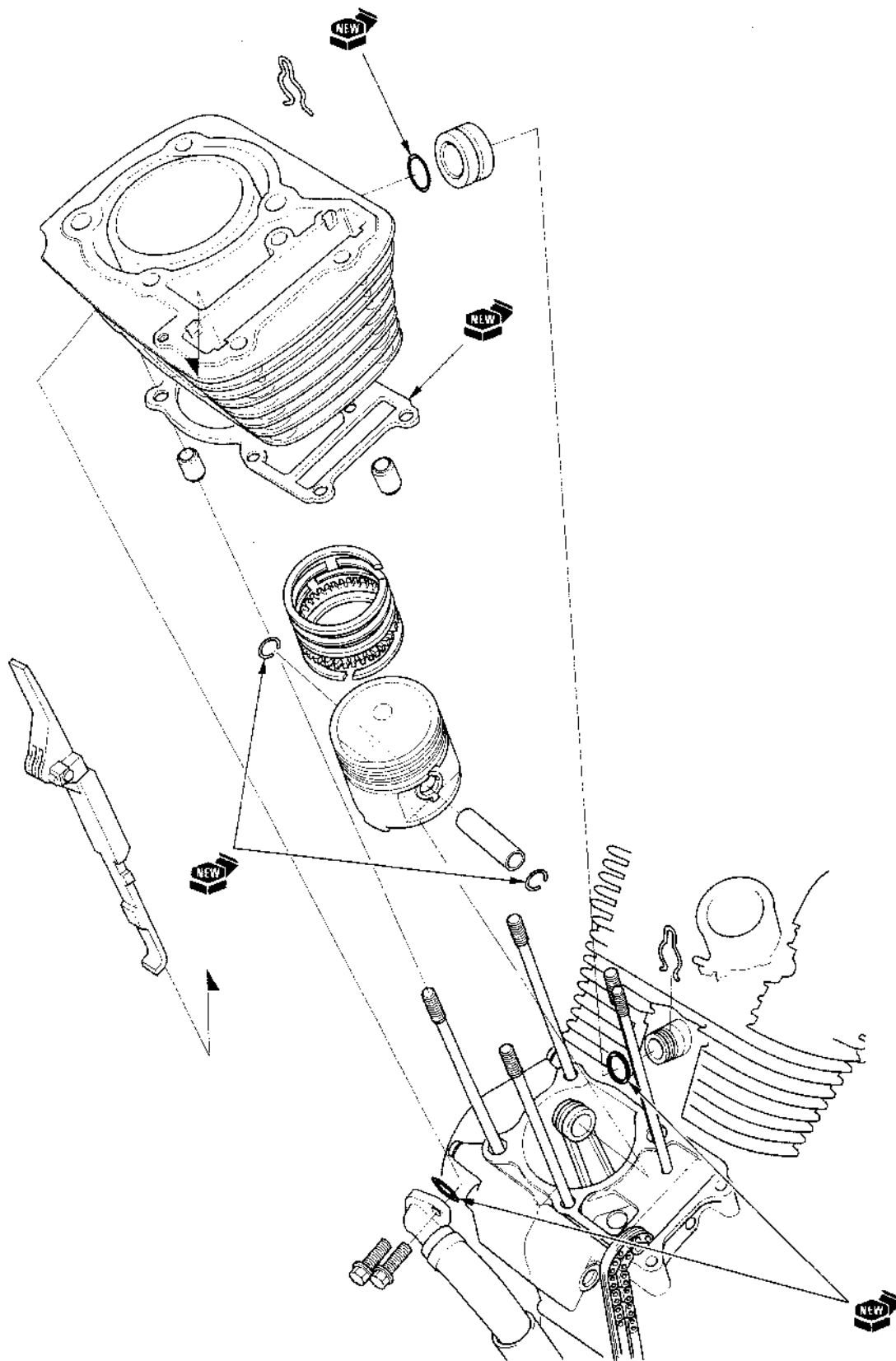



# 11. CYLINDER/PISTON

SERVICE INFORMATION	11-1	CRANKCASE STUD BOLT INSPECTION	11-7
TROUBLESHOOTING	11-2	PISTON INSTALLATION	11-8
CYLINDER REMOVAL	11-3	CYLINDER INSTALLATION	11-9
PISTON REMOVAL	11-5		

## SERVICE INFORMATION

### GENERAL

- The engine must be removed from the frame before servicing the cylinder and piston.
- Take care not to damage the cylinder wall and piston.
- Be careful not to damage the mating surfaces by using a screwdriver when disassembling the cylinder.
- Clean all disassembled parts with clean solvent and dry them using compressed air before inspection.
- When disassembling, mark and store the disassembled parts to ensure that they are reinstalled in their original locations.

### SPECIFICATIONS

Unit: mm (in)

ITEM		STANDARD	SERVICE LIMIT	
Cylinder	I.D.	75.000 – 75.015 (2.9528 – 2.9533)	75.10 (2.957)	
	Out of round	—	0.06 (0.002)	
	Taper	—	0.06 (0.002)	
	Warpage	—	0.10 (0.004)	
Piston, piston rings	Piston mark direction	"IN" mark facing toward the intake side	—	
	Piston O.D.	74.965 – 74.990 (2.9514 – 2.9524)	74.90 (2.949)	
	Piston O.D. measurement point	10 mm (0.4 in) from bottom of skirt	—	
	Piston pin bore I.D.	18.002 – 18.008 (0.7087 – 0.7090)	18.05 (0.711)	
	Piston pin O.D.	17.994 – 18.000 (0.7084 – 0.7087)	17.98 (0.708)	
	Piston-to-piston pin clearance	0.002 – 0.014 (0.0001 – 0.0006)	0.04 (0.002)	
	Piston ring-to-ring groove clearance	Top	0.015 – 0.045 (0.0006 – 0.0018)	0.10 (0.004)
		Second	0.015 – 0.045 (0.0006 – 0.0018)	0.10 (0.004)
	Piston ring end gap	Top	0.10 – 0.30 (0.004 – 0.012)	0.5 (0.02)
		Second	0.10 – 0.30 (0.004 – 0.012)	0.5 (0.02)
		Oil (side rail)	0.20 – 0.70 (0.008 – 0.028)	0.9 (0.04)
Piston ring mark	Top/second	"N" mark	—	
Cylinder-to-piston clearance		0.010 – 0.050 (0.0004 – 0.0020)	0.10 (0.004)	
Connecting rod small end I.D.		18.016 – 18.034 (0.7093 – 0.7100)	18.07 (0.711)	
Connecting rod-to-piston pin clearance		0.016 – 0.040 (0.0006 – 0.0016)	0.06 (0.002)	

### TROUBLESHOOTING

#### **Compression too low, hard starting or poor performance at low speed**

- Leaking cylinder head gasket
- Worn, stuck or broken piston rings
- Worn or damaged cylinder and piston
- Loose spark plug

#### **Compression too high, over heating or knocking**

- Excessive carbon build-up in cylinder head or on top of piston

#### **Abnormal noise**

- Worn cylinder and piston
- Worn piston pin or piston pin hole
- Worn connecting rod small end

#### **Excessive smoke**

- Worn cylinder, piston and piston rings
- Improper installation of piston rings
- Scored or scratched piston or cylinder wall

## CYLINDER REMOVAL

### NOTE:

The front cylinder service uses the same procedure as the rear cylinder.

Remove the cylinder head (page 10-12).

Remove the joint collar clips.

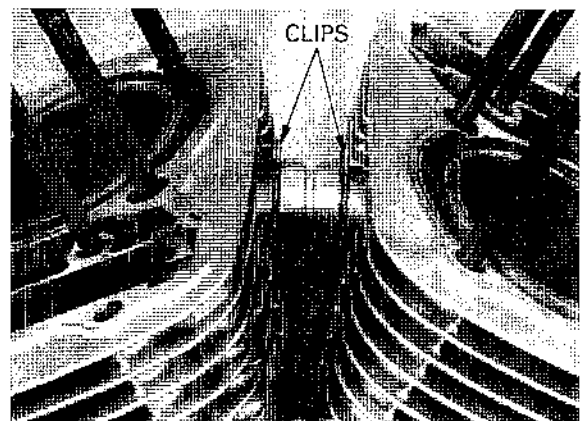

Slide the cylinder joint collar toward either the front or rear cylinder.

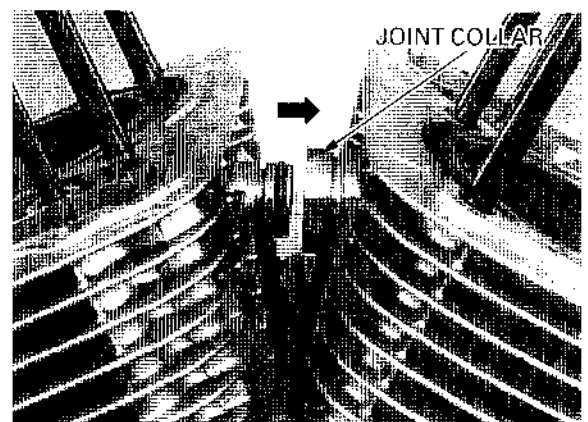

Remove the bolts, water hose joint and O-ring (front cylinder only).

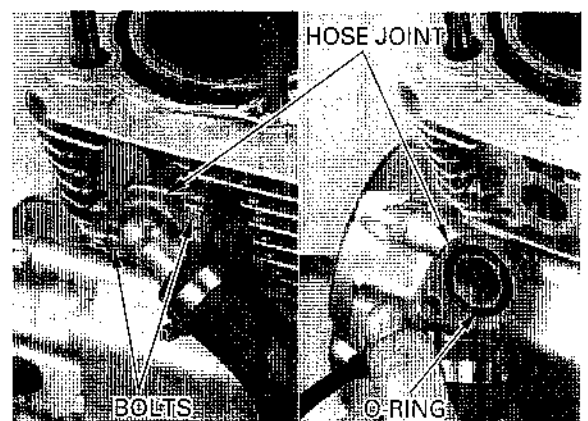

Remove the cylinder.

### NOTE:

- Attach a piece of mechanic's wire to the cam chain to prevent it from being dropped into the crankcase.
- Be careful not to damage the mating surfaces by using a screwdriver when disassembling the cylinder.

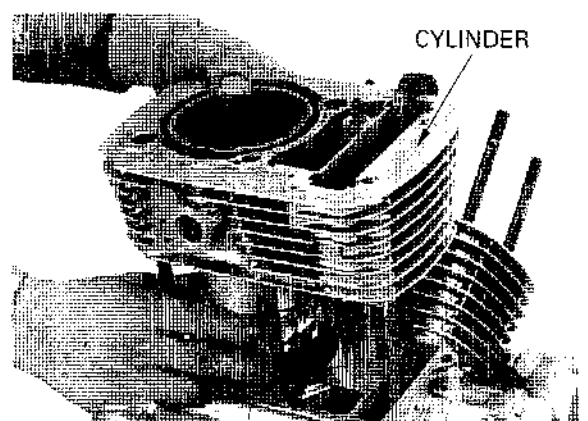

## CYLINDER/PISTON

Remove the O-ring.

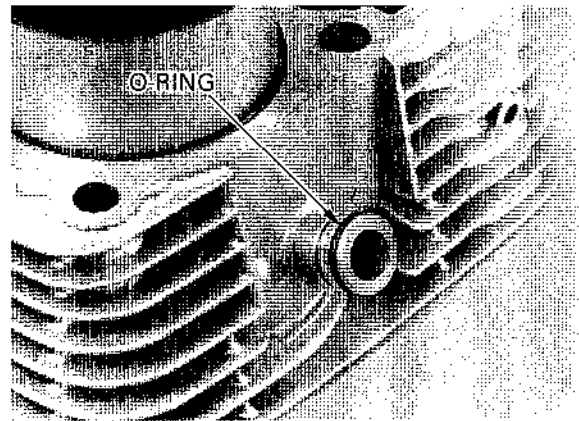

Remove the gasket and dowel pins.  
Clean off any gasket material from the cylinder upper surface.

**NOTE:**

Be careful not to damage the gasket surface.

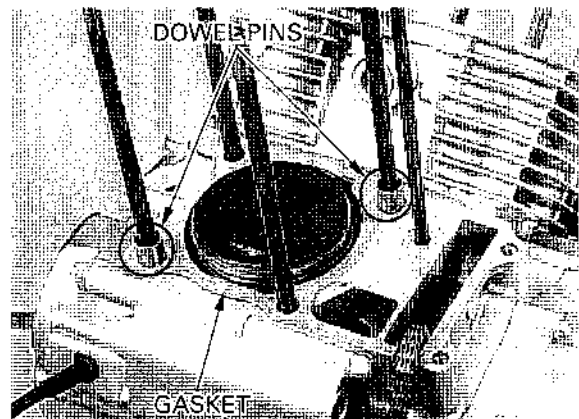

### INSPECTION

Inspect the cylinder wall for scratches and wear.  
Measure and record the cylinder I.D. at three levels in both the X and Y axes. Take the maximum reading to determine the cylinder wear.

**SERVICE LIMIT:** 75.10 mm (2.957 in)

Measure the cylinder for out of round at the three levels in an X and Y axis. Take the maximum reading to determine the out of round.

**SERVICE LIMIT:** 0.06 mm (0.002 in)

Measure the cylinder for taper at three levels in an X and Y axis. Take the maximum reading to determine the taper.

**SERVICE LIMIT:** 0.06 mm (0.002 in)

The cylinder must be rebored and an oversize piston fitted if the service limits are exceeded.

The following oversize pistons are available:  
0.25 mm (0.010 in), 0.50 mm (0.020 in).

The cylinder must be rebored so that the clearance for an oversize piston is 0.020 – 0.060 mm (0.0008 – 0.0024 in).

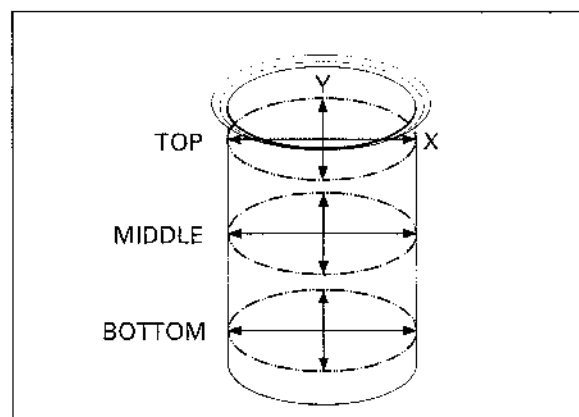
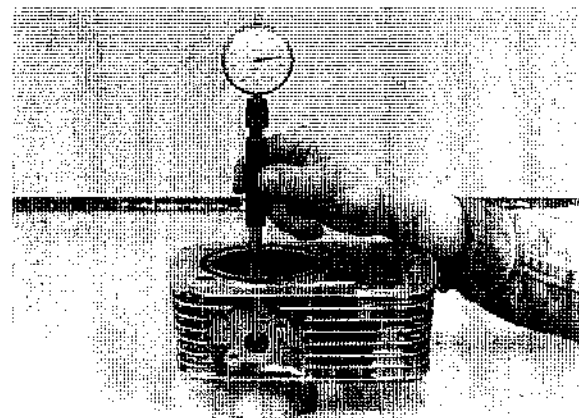

Check the cylinder for warpage by placing a straight edge and a feeler gauge.

**SERVICE LIMIT:** 0.10 mm (0.004 in)

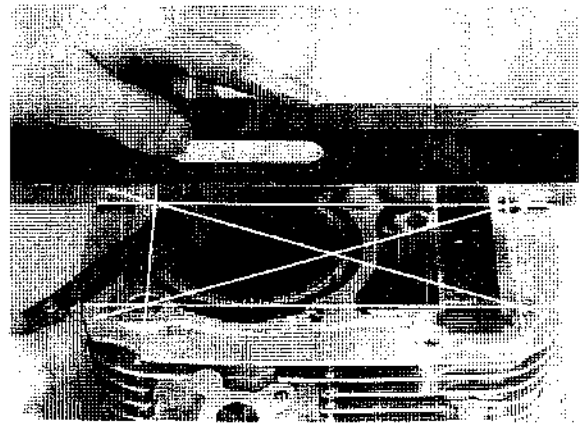

## PISTON REMOVAL

**NOTE:**

- Place a shop towel over the crankcase opening to prevent piston pin clips from falling into the crankcase.
- The rear piston service using the same procedure as for the front piston.

Remove the piston pin clip, piston pin and piston.

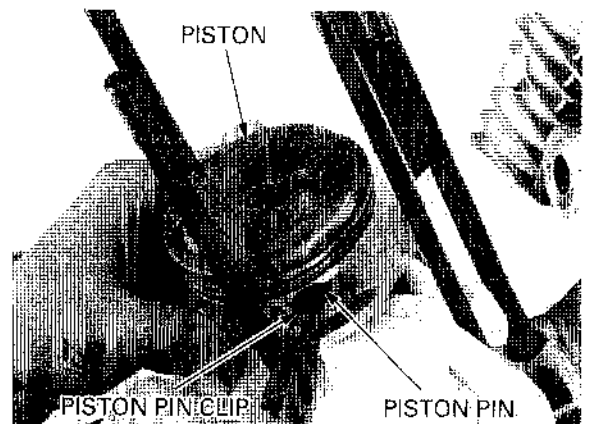

Spread each piston ring and remove it by lifting it up at a point just opposite the gap.

**CAUTION:**

- *Do not damage the piston ring by spreading the ends too far.*
- *Be careful not to damage the piston when the piston ring removal.*

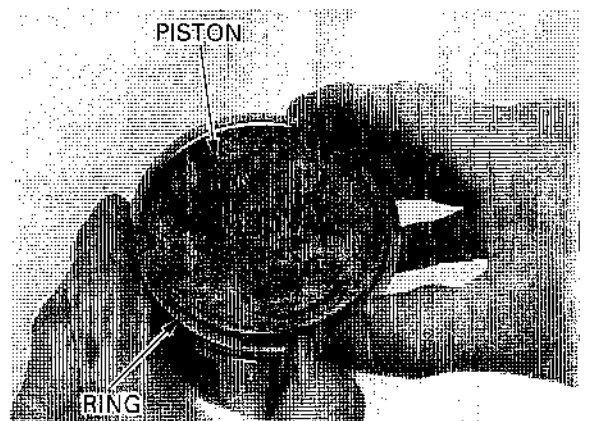

Clean carbon deposits from the piston.

**NOTE:**

Clean carbon deposits from the piston ring grooves with a ring that will be discarded. Never use a wire brush; it will scratch the grooves.

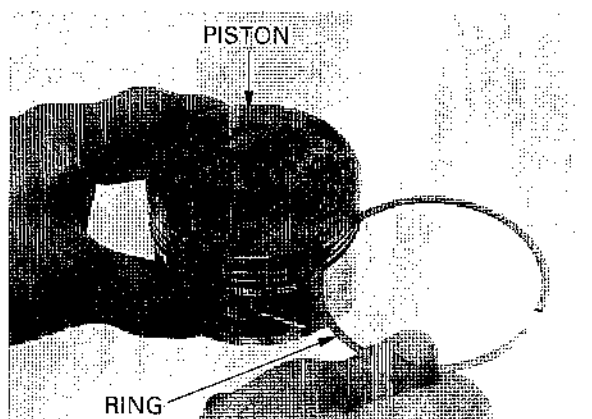

## CYLINDER/PISTON

### INSPECTION

Inspect the piston for cracks or other damage. Inspect the ring grooves for excessive wear and carbon build-up. Measure each piston O.D..

#### NOTE:

Take measurements 10 mm (0.4 in) from the bottom, and 90° to the piston pin hole.

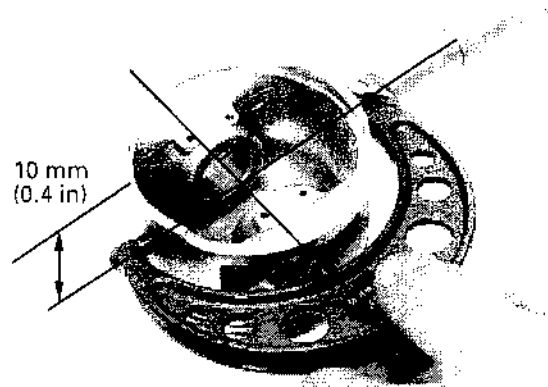

**SERVICE LIMIT:** 74.90 mm (2.949 in)

Calculate the piston-to-cylinder clearance. Take the maximum reading to determine the clearance (Cylinder I.D.: 11-4).

**SERVICE LIMIT:** 0.10 mm (0.004 in)

Measure each piston pin hole I.D. in an X and Y axis. Take the maximum reading to determine I.D..

**SERVICE LIMIT:** 18.05 mm (0.711 in)

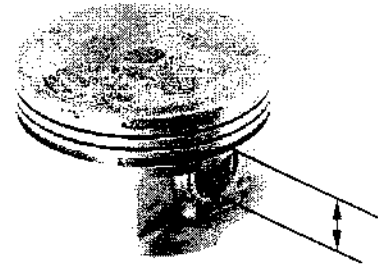

Measure the piston pin O.D. at three points.

**SERVICE LIMIT:** 17.98 mm (0.708 in)

Calculate the piston-to-piston pin clearance.

**SERVICE LIMIT:** 0.04 mm (0.002 in)

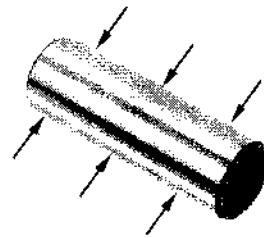

Measure the connecting rod small end I.D..

**SERVICE LIMIT:** 18.07 mm (0.711 in)

Calculate the connecting rod small end-to-piston pin clearance.

**SERVICE LIMIT:** 0.06 mm (0.002 in)



Always replace the piston rings as a set. Inspect the piston ring, and replace them if they are worn.

Reinstall the piston rings (page 11-8) into the piston grooves.

Push in the ring until the outer surface of the piston ring is nearly flush with the piston and measure the clearance using a feeler gauge.

**SERVICE LIMIT:**

- Top:** 0.10 mm (0.004 in)
- Second:** 0.10 mm (0.004 in)

Using a piston, push the ring securely into the cylinder and measure the end gap using a feeler gauge.

**SERVICE LIMIT:**

- Top:** 0.5 mm (0.02 in)
- Second:** 0.5 mm (0.02 in)
- Oil:** 0.9 mm (0.04 in)

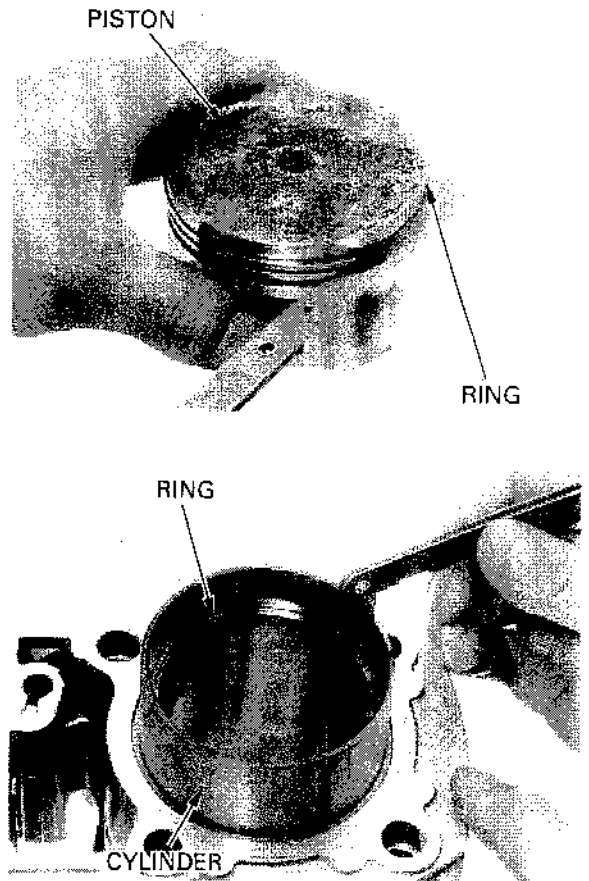

## CRANKCASE STUD BOLT INSPECTION

Check the stud bolts for looseness. If the stud bolts are loose, remove the stud bolts and apply engine oil to the threads and tighten the stud bolt securely or replace the stud bolt and clean and apply a locking agent to the new stud bolt threads and tighten the stud bolt securely.

**NOTE:**

Install the stud bolts with its tab side facing to the cylinder head side.

After installing, be sure to measure the length from the top of each stud to crankcase surface.

**STANDARD LENGTH:**

- 8 × 189 mm:** 186 mm (7.3 in)
- 10 × 177 mm:** 169 mm (6.6 in)
- 12 × 177 mm:** 169 mm (6.6 in)

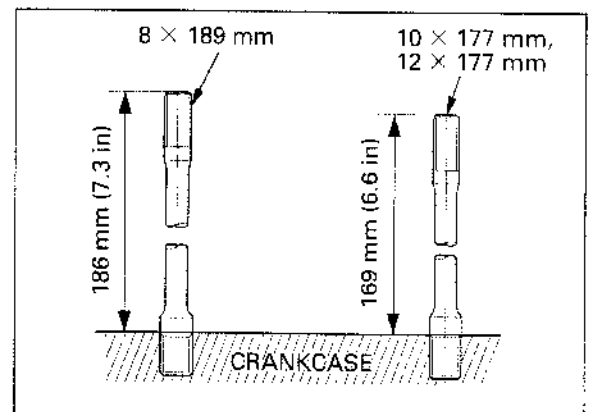
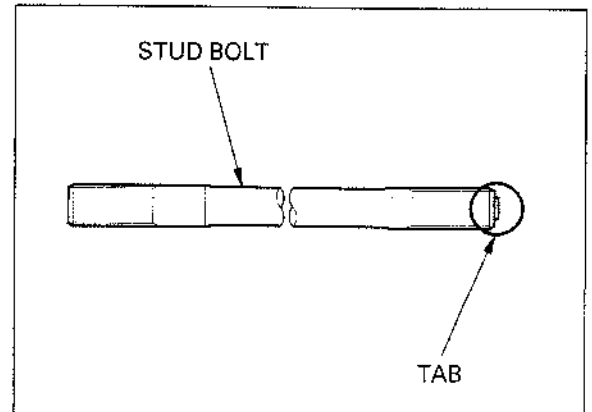

## PISTON INSTALLATION

**NOTE:**

The rear piston service uses the same procedure as the front piston.

Clean the piston heads, ring lands and skirts.

Carefully install the piston rings onto the piston with their markings facing up.

**CAUTION:**

- Do not damage the piston ring by spreading the ends too far.
- Be careful not to damage the piston when the piston ring installation.

**NOTE:**

- Do not confuse the top and second rings: The top ring is chrome-coated and second ring is not coated (black).
- After installing the rings they should rotate freely, without sticking.
- Space the ring end gaps 180 degrees apart.

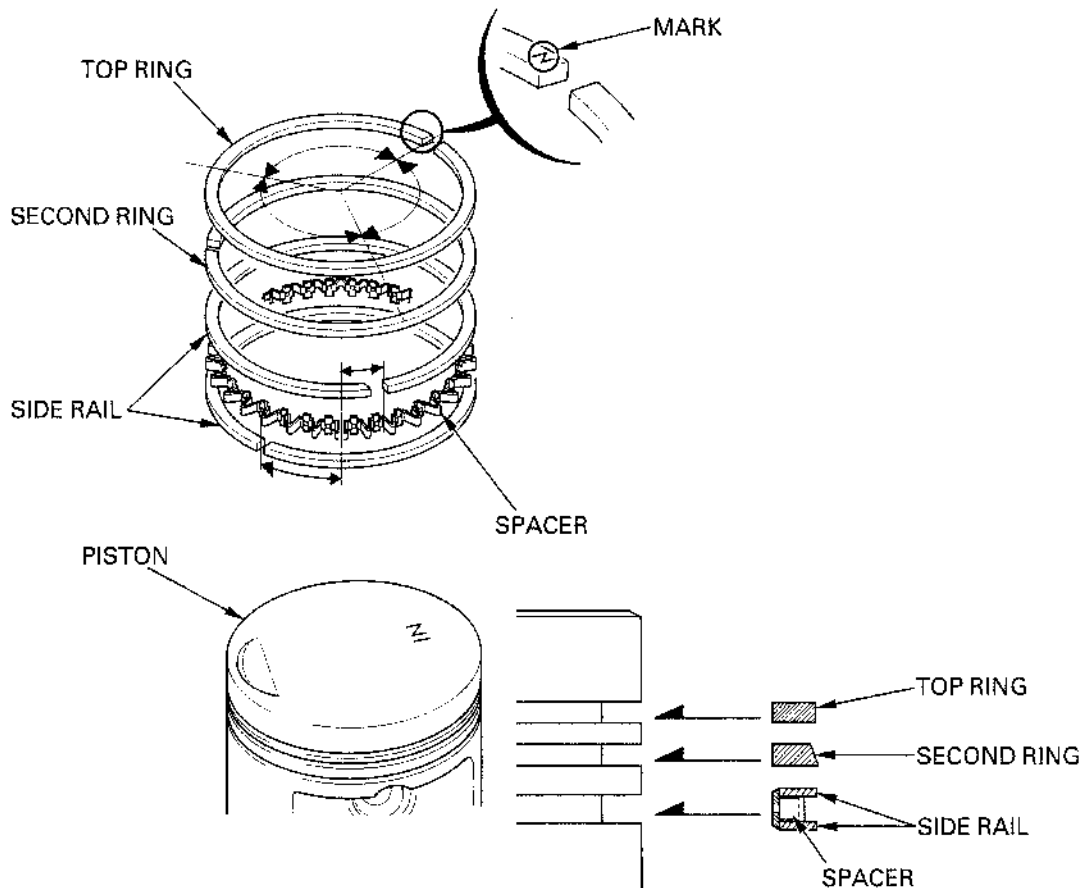
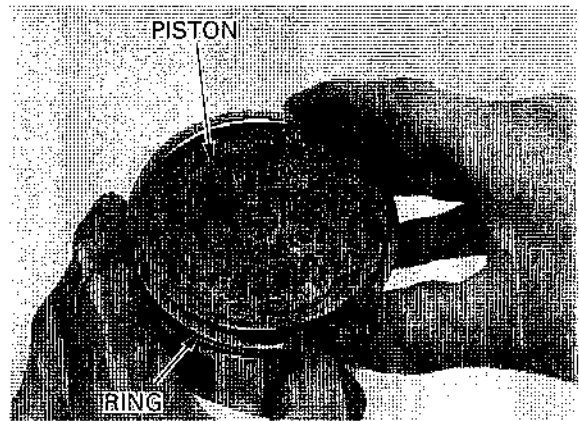



**NOTE:**

When cleaning the cylinder mating surface, place a shop towel over the cylinder opening to prevent dust or dirt enter the engine.

Clean any gasket material from the cylinder mating surfaces of the crankcase.

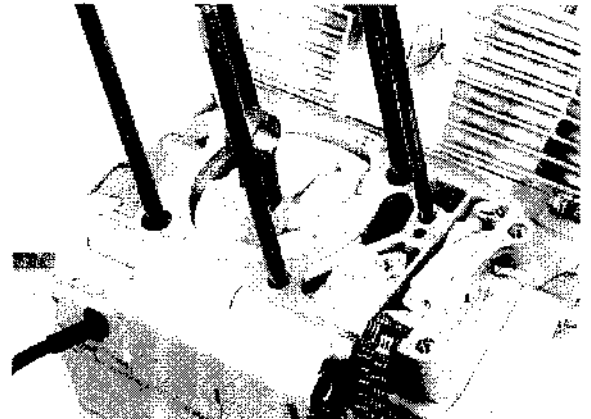

**NOTE:**

Place a shop towel over the crankcase opening to prevent piston pin clips from falling into the crankcase.

Apply molybdenum solution to the piston pin outer surfaces.

Apply engine oil to the connecting rod small end and piston pin hole.

Install the piston with its "IN" mark facing the intake side.

Install the piston pin.

Install the new piston pin clips.

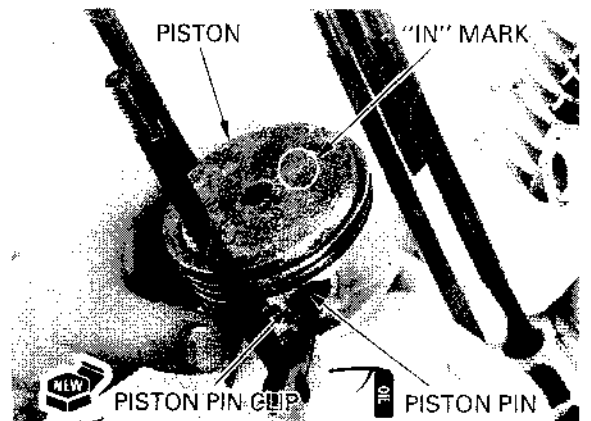

**CAUTION:**

***Always use new piston pin clips. Reinstalling used piston pin clips may lead to serious engine damage.***

**NOTE:**

- Set the piston pin clip in the groove properly.
- Do not align the clip's end gap with the piston cut-out.

## CYLINDER INSTALLATION

**NOTE:**

- The rear cylinder service using the same procedure as for the front cylinder.
- When cleaning the cylinder mating surface, place a shop towel over the cylinder opening to prevent dust or dirt enter the engine.

Install the dowel pins and new gasket.

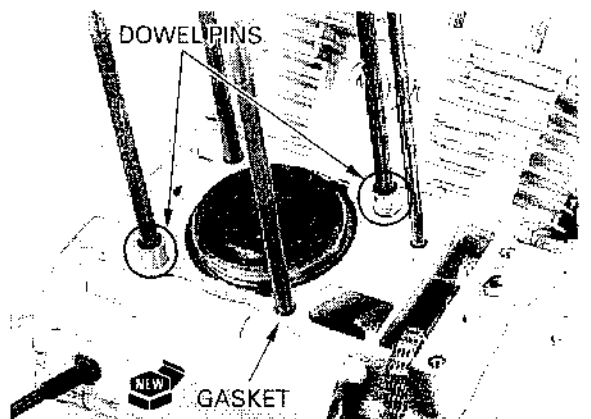

## CYLINDER/PISTON

---

Apply coolant to the new O-ring and install it to the water joint of the cylinder.

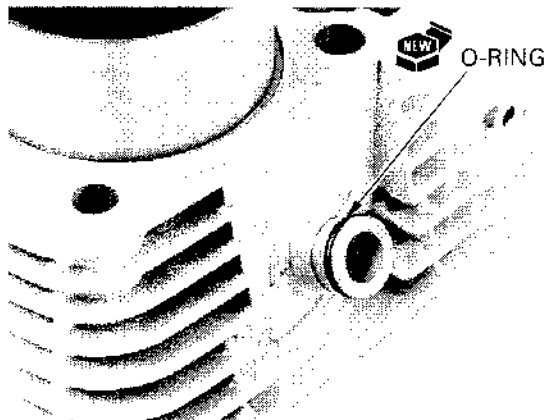

Apply engine oil to the cylinder wall and piston outer surfaces and piston rings.

**CAUTION:**

*Be careful not to damage the piston rings and cylinder walls.*

Route the cam chain through the cylinder. Install the cylinder over the piston rings by hand while compressing the piston rings.

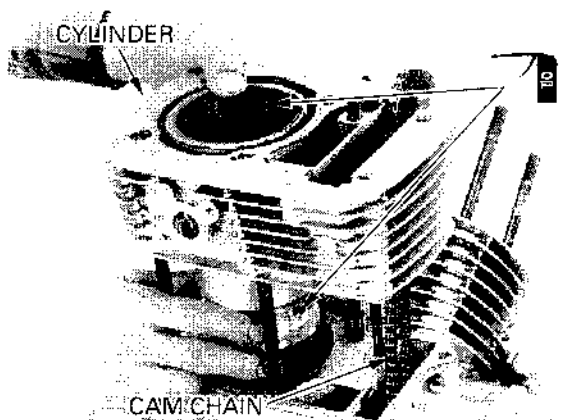

Slide the cylinder joint collar to its original position.

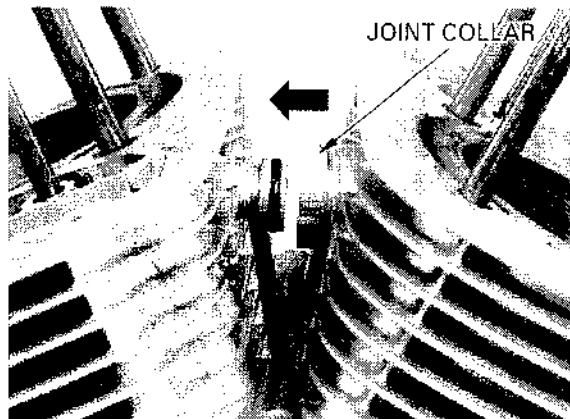

Install the joint collar clips to the groove on the water joint of the cylinder.

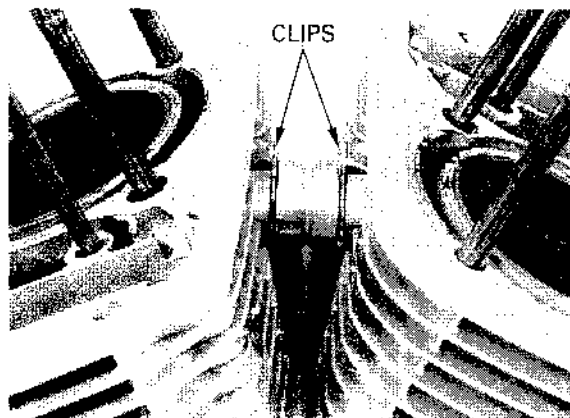

Apply coolant to the new O-ring and install it to the groove on the water hose joint of the front cylinder (front cylinder only).

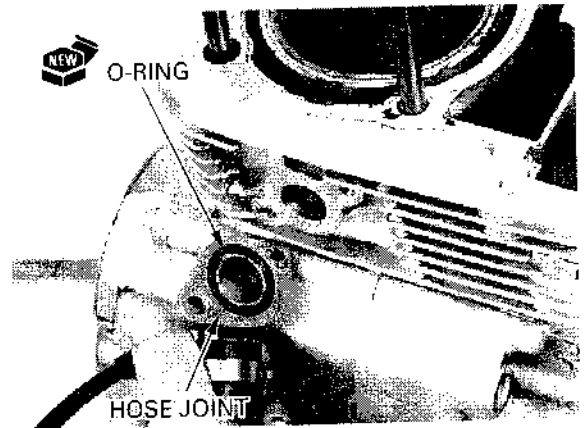

Install and tighten the hose joint bolts securely (front cylinder only).

Install the cylinder head (page 10-23).

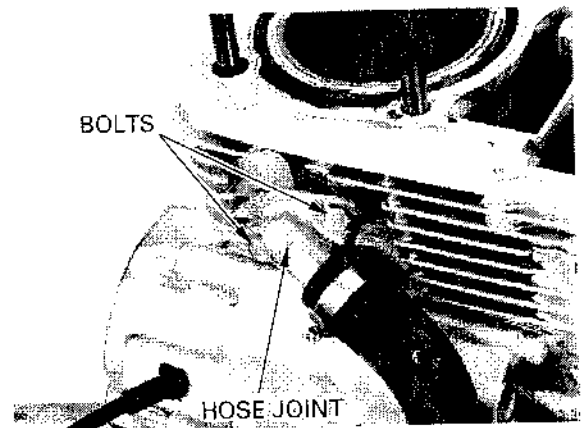

# CRANKSHAFT/TRANSMISSION

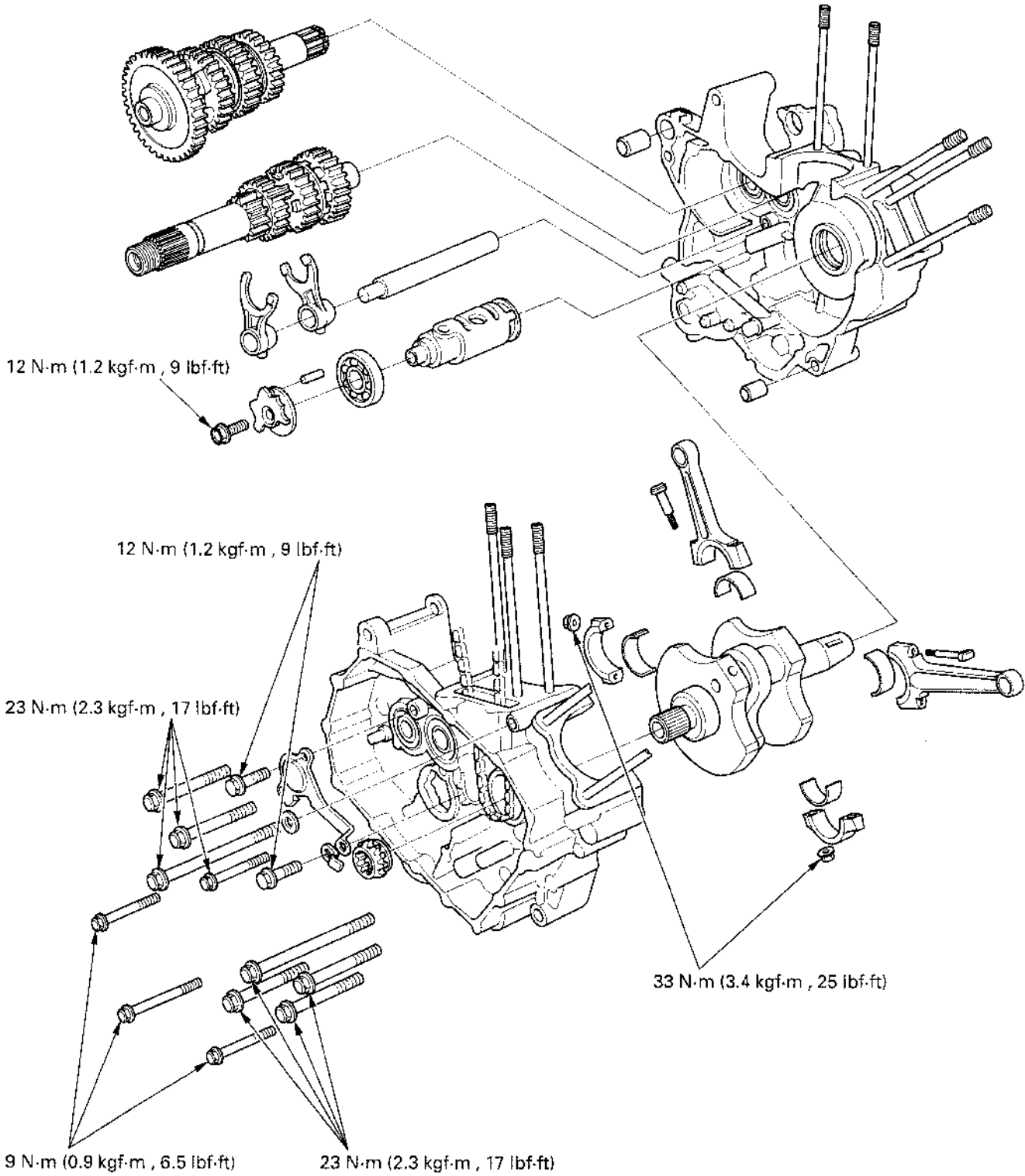

# 12. CRANKSHAFT/TRANSMISSION

SERVICE INFORMATION	12-2	TRANSMISSION	12-14
TROUBLESHOOTING	12-3	CRANKCASE BEARING REPLACEMENT	12-23
CRANKCASE SEPARATION	12-4	CRANKCASE ASSEMBLY	12-25
CRANKSHAFT/CONNECTING ROD	12-6		

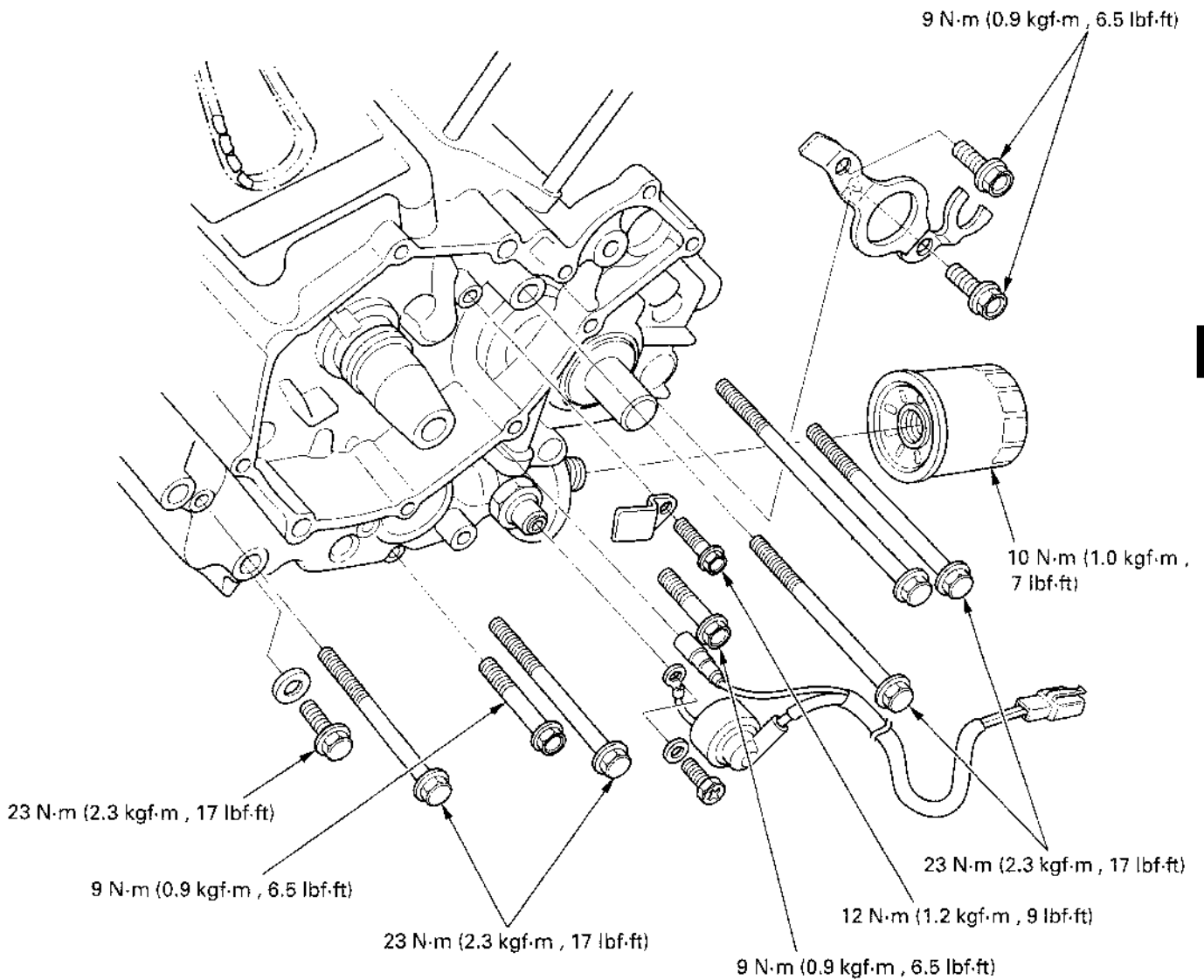

## CRANKSHAFT/TRANSMISSION

### SERVICE INFORMATION

#### GENERAL

- The crankcase halves must be separated to service the crankshaft, connecting rod and transmission (including the shift fork and shift drum). To service these parts, the engine must be removed from the engine (Section 7).
- The following parts must be removed before separating the crankcase:
  - Water pump (Section 6)
  - Cylinder head (Section 10)
  - Cylinder, piston (Section 11)
  - Clutch, gearshift linkage and primary drive gear (Section 8)
  - Alternator, flywheel (Section 9)
  - Starter motor (Section 18)
  - Neutral switch, oil pressure switch (Section 19)
- Be careful not to damage the crankcase mating surface.
- When disassembling, mark and store the disassembled parts to ensure that they are reinstalled in their original locations.
- Connecting rod and crankshaft bearing inserts are select fitted and are identified by color code. Select the replacement bearings using the selection tables. After installing new bearings, recheck them with plastigauge to verify correct clearance.
- Clean and apply sealant to the crankcase mating surfaces. Wipe off excess sealant thoroughly.

#### SPECIFICATIONS

Unit: mm (in)

ITEM		STANDARD	SERVICE LIMIT
Crankshaft	Side clearance	0.05 – 0.20 (0.002 – 0.008)	0.30 (0.012)
	Runout		0.05 (0.002)
	Crank pin oil clearance	0.028 – 0.052 (0.0011 – 0.0020)	0.07 (0.003)
	Main journal oil clearance 50 dia.	0.025 – 0.041 (0.0010 – 0.0016)	0.06 (0.002)
Transmission	Gear I.D.	M2, M4, C3	28.000 – 28.021 (1.1024 – 1.1032)
		C1	24.000 – 24.021 (0.9449 – 0.9457)
	Bushing O.D.	M2, M4, C3	27.959 – 27.980 (1.1007 – 1.1016)
		C1	23.959 – 23.980 (0.9433 – 0.9441)
	Bushing I.D.	M2	25.000 – 25.021 (0.9843 – 0.9851)
		C1	20.016 – 20.037 (0.7880 – 0.7889)
	Gear-to-bushing clearance	M2, M4	0.020 – 0.062 (0.0008 – 0.0024)
		C1, C3	0.020 – 0.062 (0.0008 – 0.0024)
	Mainshaft O.D.	M2 bushing	24.959 – 24.980 (0.9826 – 0.9835)
	Countershaft O.D.	C1 bushing	19.980 – 19.993 (0.7866 – 0.7871)
Shift fork, fork shaft	Bushing-to-shaft clearance	M2	0.020 – 0.062 (0.0008 – 0.0024)
		C1	0.023 – 0.057 (0.0009 – 0.0022)
	Fork	I.D.	13.000 – 13.018 (0.5118 – 0.5125)
		Claw thickness	5.93 – 6.00 (0.233 – 0.236)
Fork shaft O.D.		12.966 – 12.984 (0.5105 – 0.5112)	
Shift drum O.D. (at left side journal)		11.966 – 11.984 (0.4711 – 0.4718)	

**TORQUE VALUES**

Mainshaft bearing set plate bolt	12 N·m (1.2 kgf·m , 9 lbf·ft)	Apply a locking agent to the threads
Countershaft bearing set plate bolt	9 N·m (0.9 kgf·m , 6.5 lbf·ft)	Apply a locking agent to the threads
Cam chain tensioner set plate bolt	12 N·m (1.2 kgf·m , 9 lbf·ft)	Apply a locking agent to the threads
Crankcase 8 mm bolt	23 N·m (2.3 kgf·m , 17 lbf·ft)	
6 mm bolt	'97—'98: 9 N·m (0.9 kgf·m , 6.5 lbf·ft)	
	After '98: 12 N·m (1.2 kgf·m , 9 lbf·ft)	
Connecting rod bearing cap nut	33 N·m (3.4 kgf·m , 25 lbf·ft)	Apply oil to the threads and seating surface

**TOOLS**

Attachment, 42 × 47 mm	07746—0010300	
Attachment, 52 × 55 mm	07746—0010400	
Pilot, 20 mm	07746—0040500	
Pilot, 25 mm	07746—0040600	
Pilot, 22 mm	07746—0041000	
Driver	07749—0010000	
Main bearing driver attachment	07HMF—MM90400	
Bearing remover set	07936—3710001	Not available in U.S.A. or 07936—3710200
— Remover weight	07741—0010201	
— Remover handle	07936—3710100	
— Bearing remover head	07936—3710600	

**TROUBLESHOOTING**

**Excessive noise**

- Worn connecting rod big end bearing
- Bent connecting rod
- Worn crankshaft main bearing
- Worn transmission gear

**Hard to shift**

- Improper clutch adjustment
- Improper clutch operation
- Bent shift fork
- Bent shift fork shaft
- Bent shift spindle
- Damaged shift drum cam grooves
- Incorrect engine oil weight

**Transmission jumps out of gear**

- Worn gear dogs or slots
- Bent fork shaft
- Broken shift drum stopper
- Worn or bent shift forks
- Broken gearshift linkage return spring

### CRANKCASE SEPARATION

Remove the engine from the frame (Section 7).

Refer to Service Information (page 12-1) for removal of necessary parts before disassembling the crankcase.

Remove the bolts and countershaft bearing set plate.  
Remove the engine sub harness.

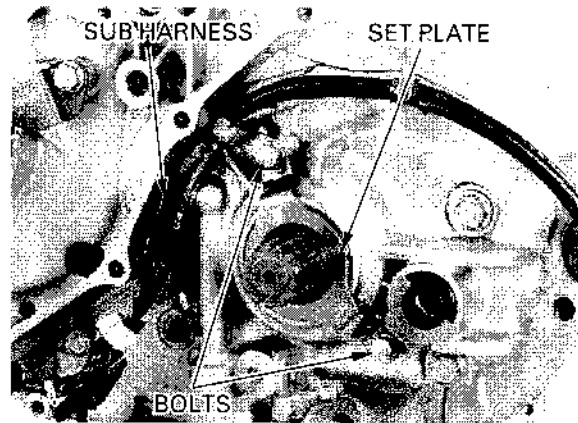

Remove the bolt and front cam chain tensioner set plate.  
Remove the front cam chain from the crankshaft.

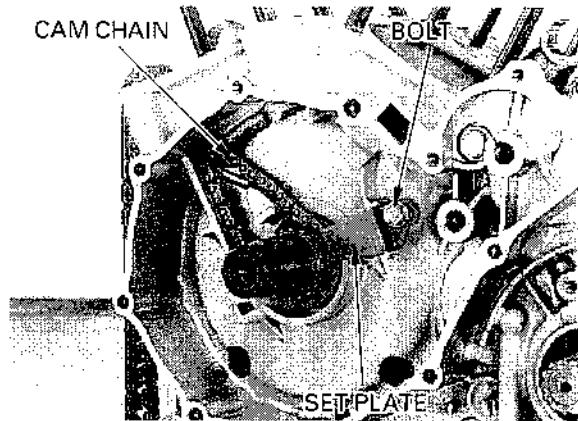

Remove the bolt and rear cam chain tensioner set plate.  
Remove the rear cam chain and cam chain drive sprocket.

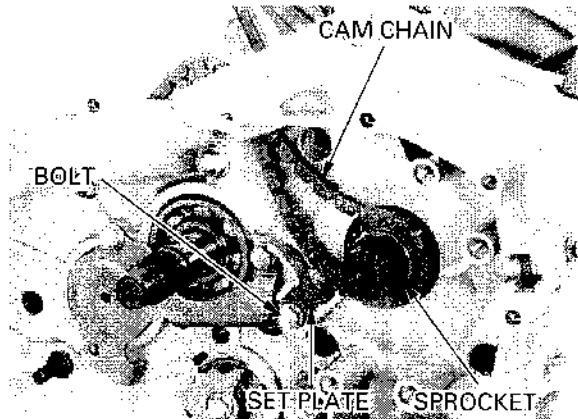

Remove the mainshaft bearing set plate by removing the bolts.

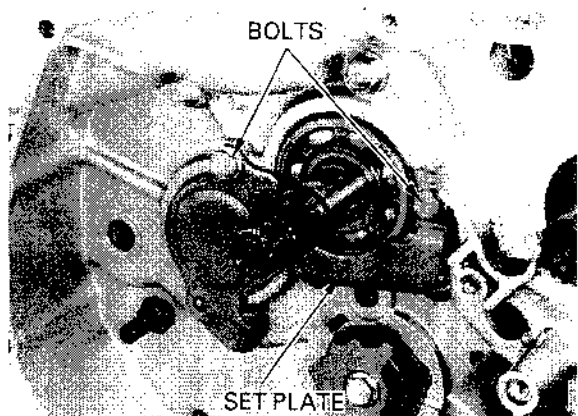



Remove the bolt and gearshift cam plate.

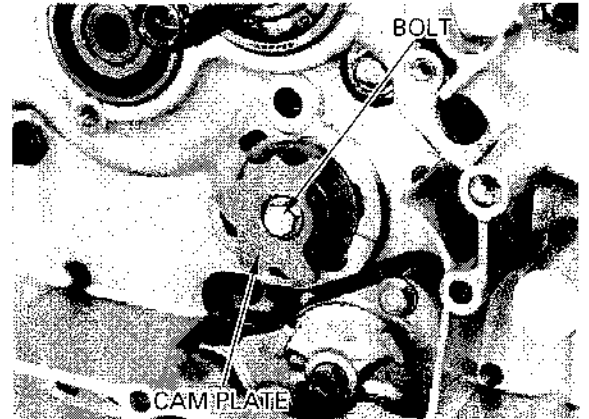

Remove the left crankcase bolts.

**NOTE:**

- Loosen the 6 mm bolts first, then 8 mm bolts.
- Loosen the left crankcase bolts in a crisscross pattern in several steps.

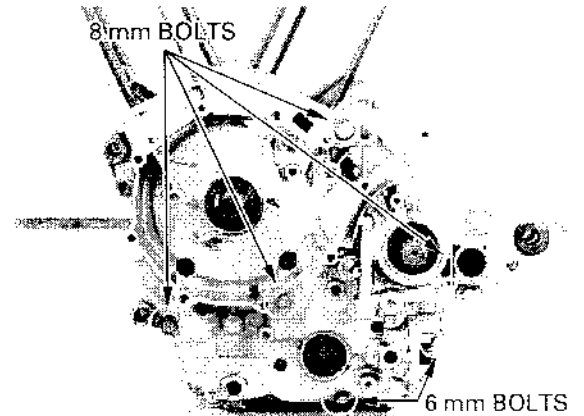

Remove the right crankcase bolts.

**NOTE:**

- Loosen the 6 mm bolts first, then 8 mm bolts.
- Loosen the right crankcase bolts in a crisscross pattern in several steps.

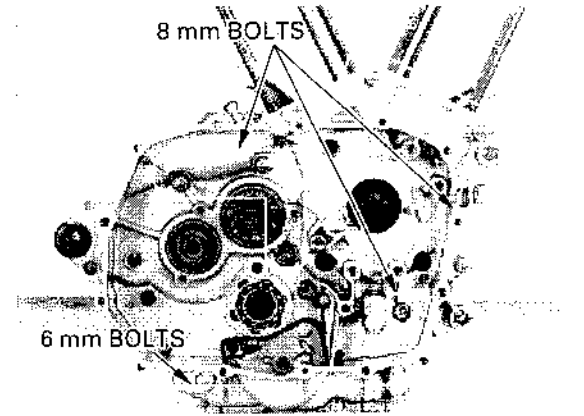

Place the crankcase with the left crankcase down and remove the right crankcase.

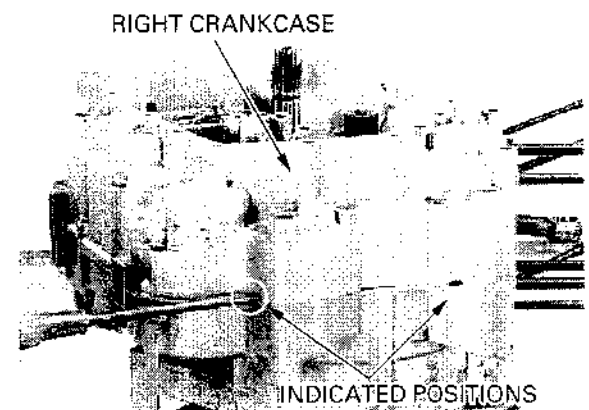

## CRANKSHAFT/TRANSMISSION

### NOTE:

- Separate the right crankcase from the left crankcase while prying at the points as shown.
- Separate the right crankcase from the left crankcase while tapping them at several locations with a soft hammer.

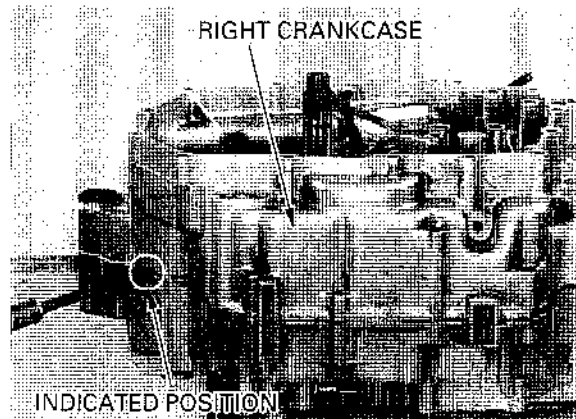

Remove the dowel pins.  
Clean off the sealant from the left and right crankcase mating surfaces.

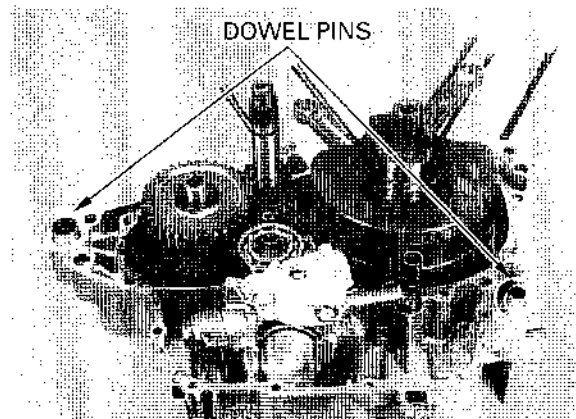

## CRANKSHAFT/CONNECTING ROD

### CAUTION:

*Be careful not to damage the crankshaft main bearing and connecting rod bearing while servicing the crankshaft/connecting rod.*

### REMOVAL

Separate the crankcase (page 12-4).

Remove the crankshaft/connecting rod from left crankcase.

### INSPECTION

Inspect the connecting rod big end side clearance. Measure the side clearance by inserting the feeler gauge between the crankshaft and connecting rod large end as shown.

**STANDARD:** 0.30 mm (0.012 in)

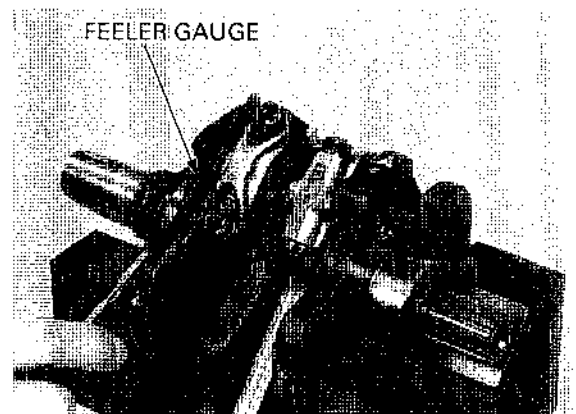
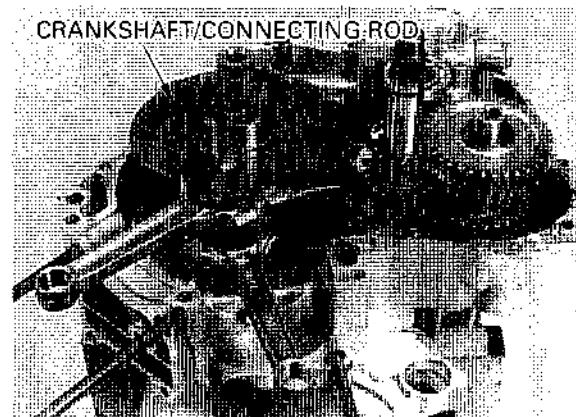

Place the crankshaft on V-blocks.  
 Rotate the crankshaft two revolutions and read the runout with a dial indicator.  
 Divide the total indicator reading in half to get the actual runout.

**SERVICE LIMIT:** 0.05 mm (0.002 in)

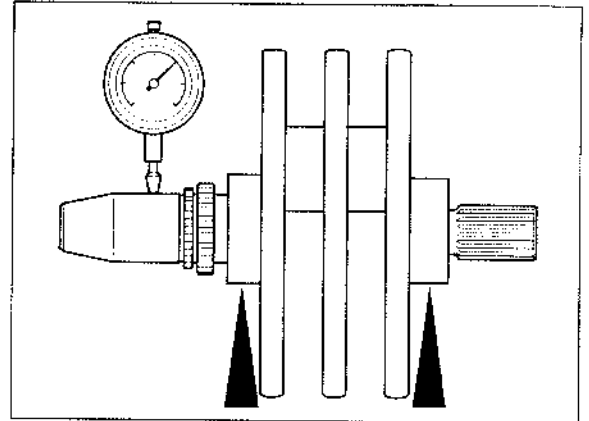

Remove the connecting rod bearing cap nuts, bearing caps and connecting rod.

**NOTE:**

Tap the side of the cap lightly if the bearing cap is hard to remove.

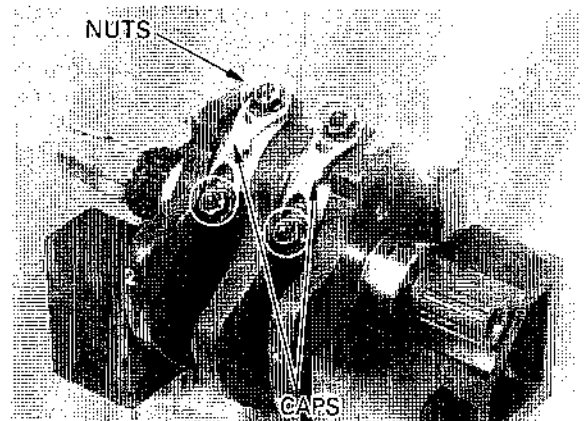

Mark the bearing caps, bearings and connecting rod as you remove them to indicate the correct cylinder and position on the crankpins for reassembly.

Connecting rod small end inspection (page 11-6)

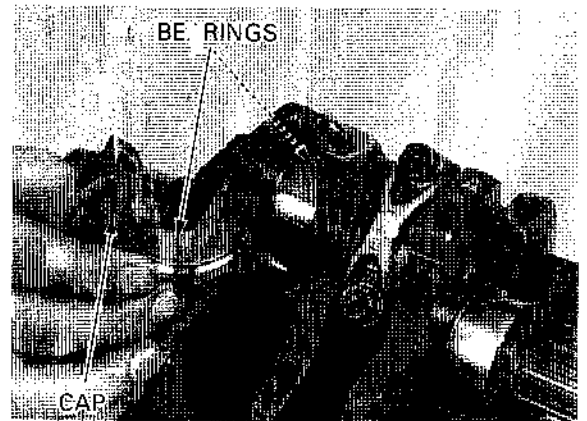

**CONNECTING ROD BEARING INSPECTION**

Inspect the bearing inserts for unusual wear, damage or peeling and replace if necessary.

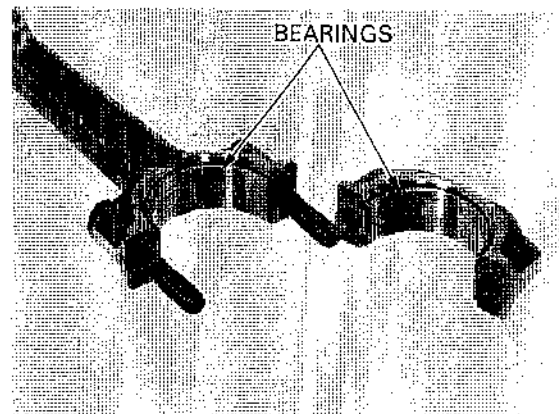

## CRANKSHAFT/TRANSMISSION

### CRANKPIN OIL CLEARANCE

*Do not rotate the crankshaft during inspection.*

Clean off any oil from the connecting rod bearing inserts and crankpin. Put a strip of plastigauge on each crank pin avoiding oil hole.

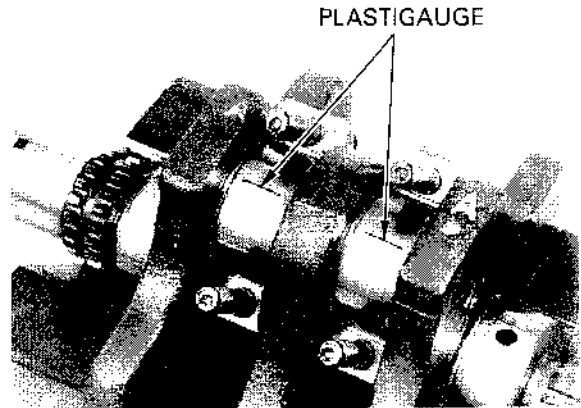

Install the connecting rod bearing and bearing cap to the original location. Install and tighten the connecting rod bearing cap nuts in a crisscross pattern in several steps.

**TORQUE:** 33 N·m (3.4 kgf·m, 25 lbf·ft)

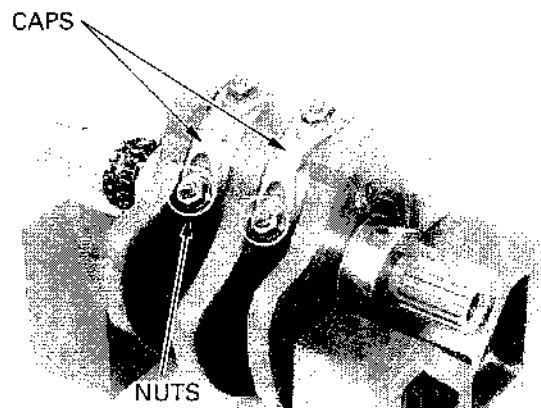

Remove the connecting rod bearing cap nuts, bearing cap and bearing. Measure the compressed plastigauge at its widest point on each crank pin to determine the oil clearance.

**SERVICE LIMIT:** 0.07 mm (0.003 in)

If the clearance exceeds the service limit, select the correct replacement bearings as follows.

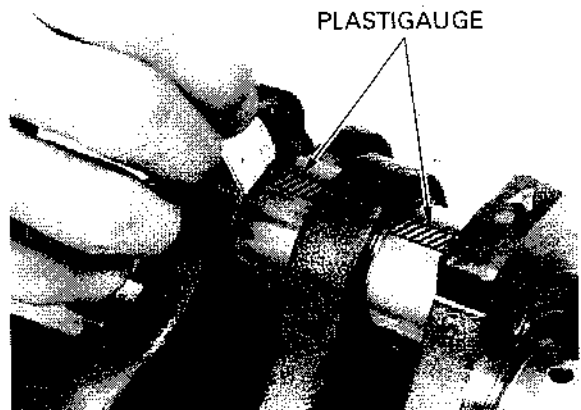

### CONNECTING ROD BEARING SELECTION

Determine the connecting rod I.D. number. The code will be either a number 1 or 2 located on the rod in the area shown.

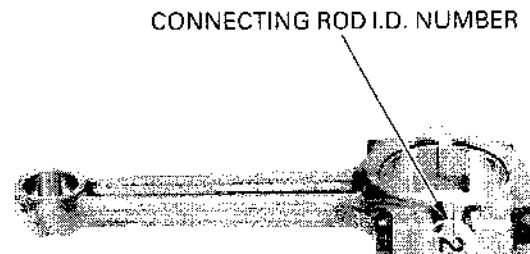

Determine the corresponding crankpin O.D. code (or measure the crankpin O.D.). The code will be either a letter A or B on the crank weight.

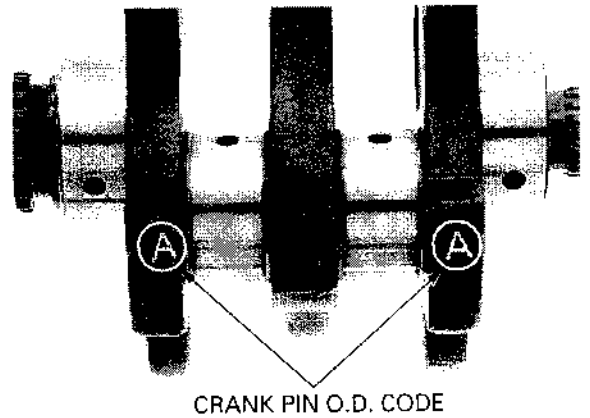

Cross reference the crankpin and connecting rod codes to determine the replacement bearing collar.

Unit: mm (in)

Crankpin O.D. code		A	B
Connecting rod I.D. code		39.982 - 39.990 (1.5741 - 1.5744)	39.974 - 39.981 (1.5738 - 1.5741)
1	43.000 - 43.007 (1.6929 - 1.6932)	C (Brown)	B (Black)
2	43.008 - 43.016 (1.6932 - 1.6935)	B (Black)	A (Blue)

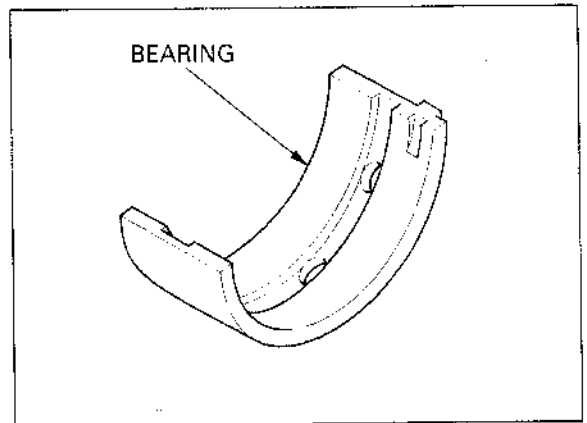

**BEARING INSERT THICKNESS:**

- A (Blue): 1.495 - 1.499 mm (0.0589 - 0.0590 in)
- B (Black): 1.491 - 1.495 mm (0.0587 - 0.0589 in)
- C (Brown): 1.487 - 1.491 mm (0.0585 - 0.0587 in)

**CONNECTING ROD/CRANKSHAFT SELECTION**

Connecting rod and crankshaft are select fitted. Record the connecting rod weight code (A, B or C). Record the crankshaft weight code (L, H or No code).

If the connecting rod and/or crankshaft are replaced, select them with the following fitting table.

**NOTE:**

The "O" mark in the table indicates that mating is possible in the crossed codes.

CONNECTING ROD WEIGHT CODE

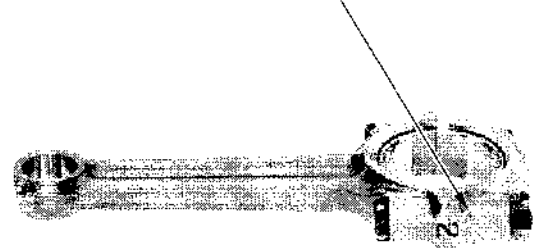

# CRANKSHAFT/TRANSMISSION

Unit: mm (in)

Front connecting rod weight code	A	B	C
Rear connecting rod weight code			
A	*	○	○
B	○	○	○
C	○	○	**

## CRANKSHAFT WEIGHT CODE

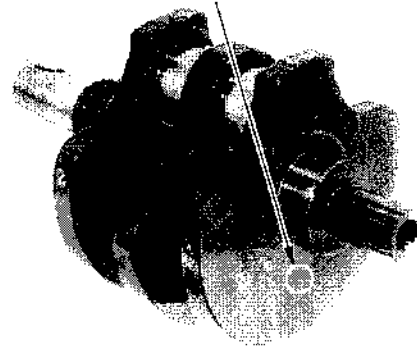

### CAUTION:

*For selecting crankshaft weight.*

- Select "L" crankshaft weight, if the front rod and rear rod have code A (\*).
- Select "H" crankshaft weight, if the front rod and rear rod have code C (\*\*).
- Select crankshaft weight with no code, other than the above two cases.

## CRANKSHAFT/CRANKCASE SELECTION

Crankcase and crankshaft are select fitted.

Record the main journal O.D. code number (1 or 2).

Record the main bearing I.D. code (A or B).

If the crankcase and/or crankshaft are replaced, select them with the following fitting table.

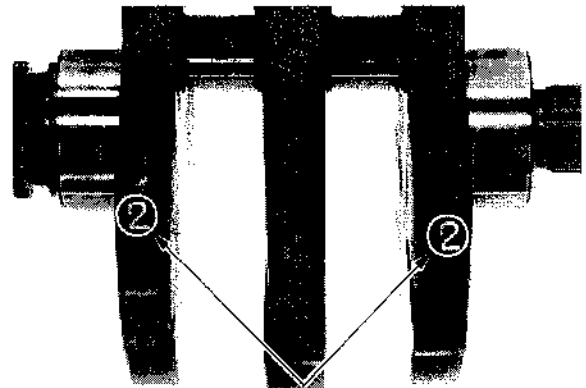

MAIN JOURNAL O.D. CODE NUMBER

### NOTE:

The "○" mark in the table indicates that mating is possible in the crossed codes.

Main journal O.D. code	1	2
Main bearing I.D. code		
A	○	
B		○

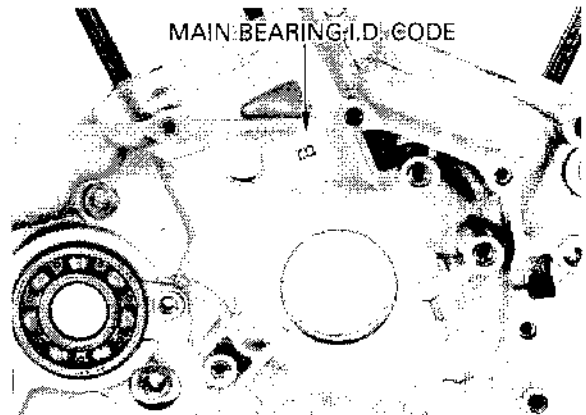

MAIN BEARING I.D. CODE

### MAIN BEARING INSPECTION

Inspect the bearing inserts for unusual wear, damage or peeling and replace if necessary.

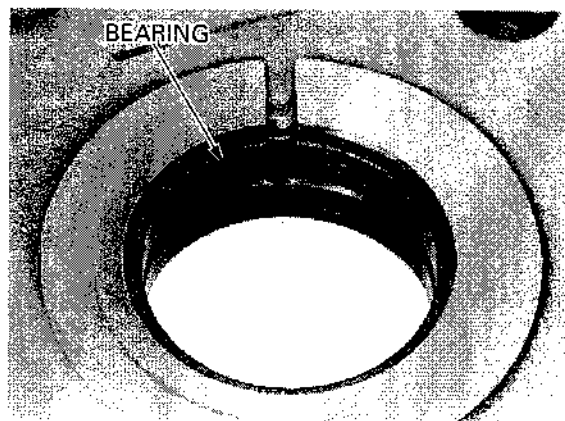

### MAIN BEARING OIL CLEARANCE

Clean off any oil from the main bearing inserts and crankshaft journals.

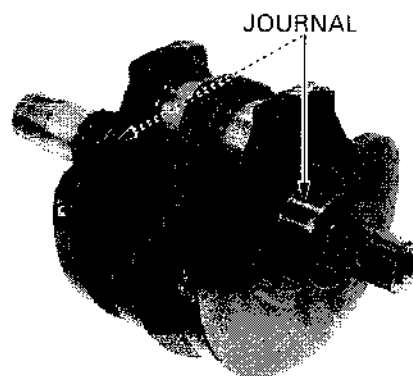

Measure and record the crankshaft main journal O.D..

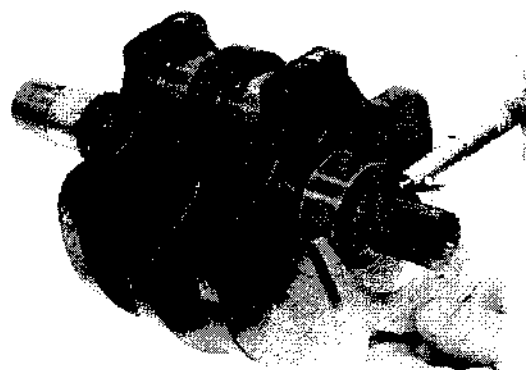

Measure and record the main bearing I.D..

Calculate the oil clearance by subtracting the journal O.D. from bearing I.D..

**SERVICE LIMIT:** 0.06 mm (0.002 in)

Replace the bearing if the service limit is exceeded. Select the replacement bearing (see below).

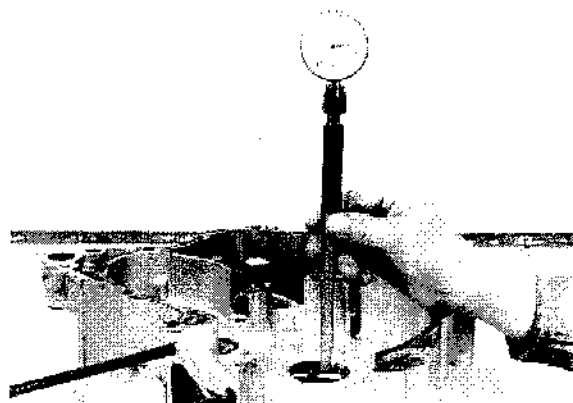

# CRANKSHAFT/TRANSMISSION

## MAIN BEARING SELECTION

Record the main journal O.D. code number (1 or 2).

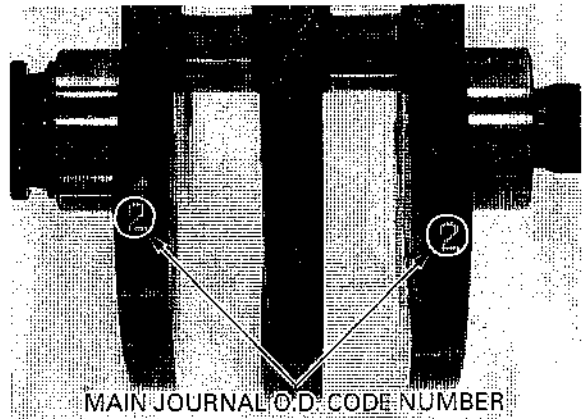

Press out the main bearing using the special tools and hydraulic press:

### CAUTION:

*When removing bearings, always use a hydraulic press and special tools to prevent crankcase damage.*

### TOOLS:

**Driver** 07749-0010000  
**Main bearing driver attachment** 07HMF-MM90400

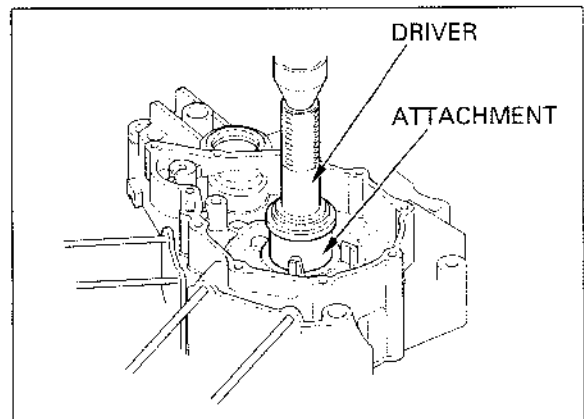

Measure and record the crankcase I.D. (A or B).

Cross-reference the crankcase and main journal codes to determine the replacement bearing color.

Unit: mm (in)

Main journal O.D. code		1	2
Crankcase I.D. code		44.992 - 45.000 (1.7713 - 1.7717)	44.984 - 44.991 (1.7710 - 1.7713)
A	48.990 - 49.000 (1.9287 - 1.9291)	C (Brown)	B (Black)
B	49.000 - 49.010 (1.9291 - 1.9295)	B (Black)	A (Blue)

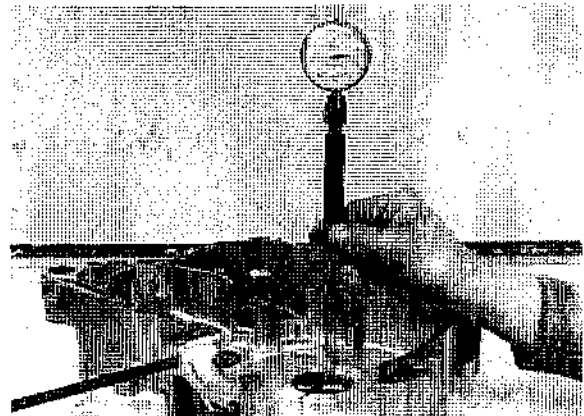

### BEARING INSERT THICKNESS:

A (Blue): 2.003 - 2.013 mm (0.0789 - 0.0793 in)  
 B (Black): 1.998 - 2.008 mm (0.0787 - 0.0791 in)  
 C (Brown): 1.993 - 2.003 mm (0.0785 - 0.0789 in)

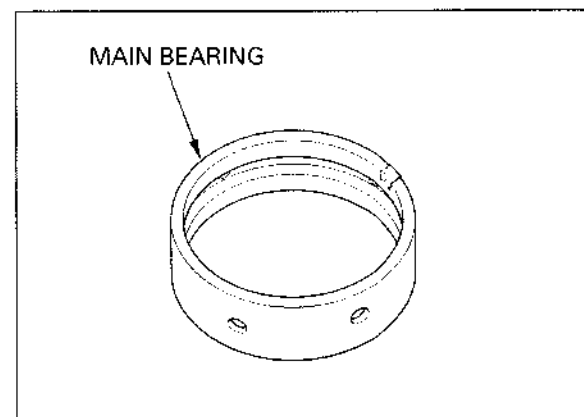



Apply molybdenum disulfide oil to the outer surface of the new main bearing.  
 Place the bearing in the crankcase by aligning the tab with the crankcase groove.  
 Press the main bearing into the crankcase.

*At installation, align the bearing oil hole with the crankcase oil hole.*

**CAUTION:**

***Be careful not to damage the bearing.***

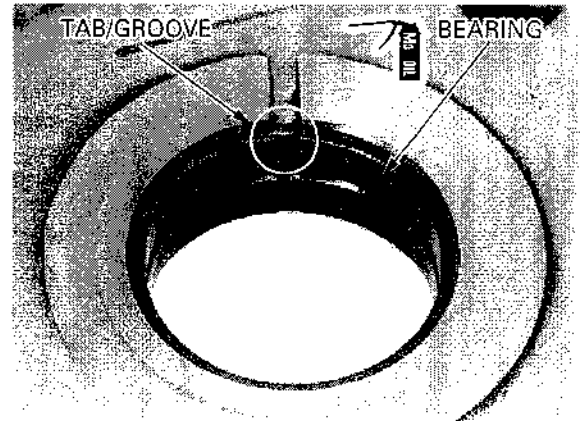

**TOOLS:**

**Driver** 07749-0010000  
**Main bearing driver attachment** 07HMF-MM90400

**NOTE:**

If the main bearing is replaced, record the new main bearing I.D. code letter on the crankcase.

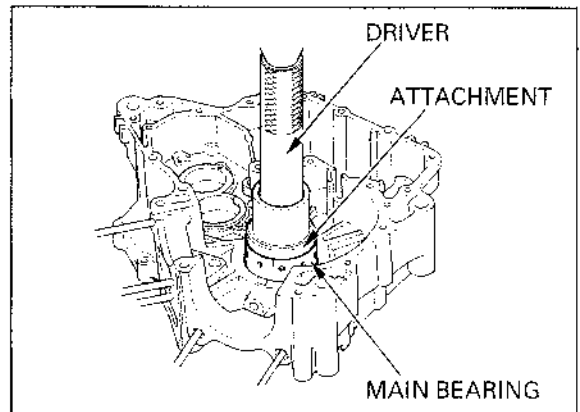

**INSTALLATION**

Clean off any oil from the main bearing inserts and connecting rod bearing cap.  
 Install the main bearing to the connecting rod and bearing cap by aligning the tab on the bearing with the groove on the connecting rod and bearing cap.

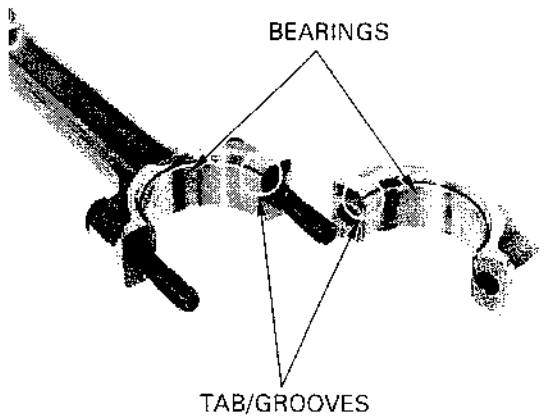

Install the connecting rods and bearing caps on the crankpin.  
 Be sure the each part is installed in its original position.

**NOTE:**

Align the I.D. code on the bearing cap and connecting rod.

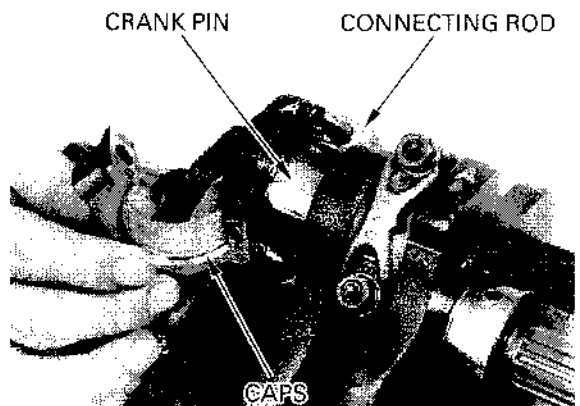

## CRANKSHAFT/TRANSMISSION

Apply oil to the connecting rod bearing cap nut threads and flange surface. Install and tighten the connecting rod bearing cap nuts to the specified torque in several steps.

**TORQUE:** 33 N·m (3.4 kgf·m , 25 lbf·ft)

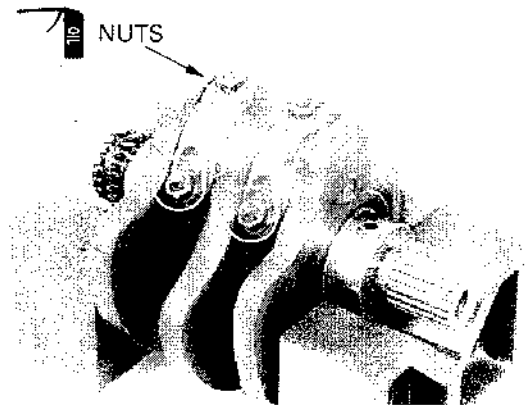

After tightening, check that the connecting rods move freely without binding.

Apply molybdenum disulfide oil to the main bearing sliding surfaces and install the crankshaft into the left crankcase.

Assemble the crankcase (page 12-24).

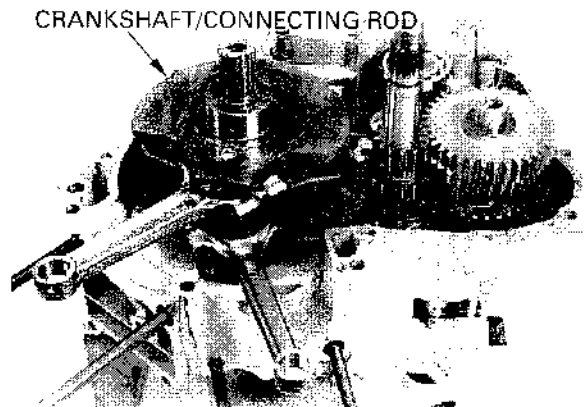

## TRANSMISSION

### REMOVAL

Separate the crankcase (page 12-4).

Remove the shift fork shaft from the shift forks.  
Remove the shift drum and shift forks.

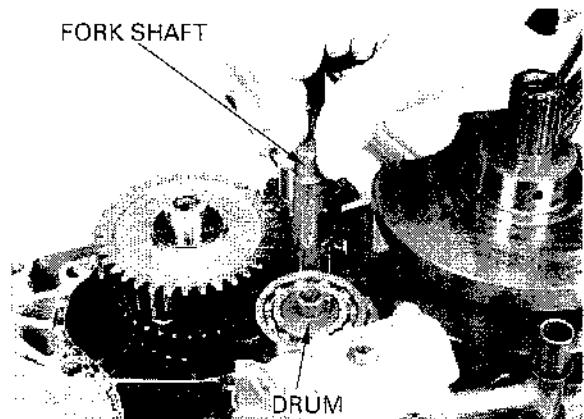

*Do not forget to install the transmission end washer.* Remove the mainshaft and countershaft from the left crankcase as assembly.

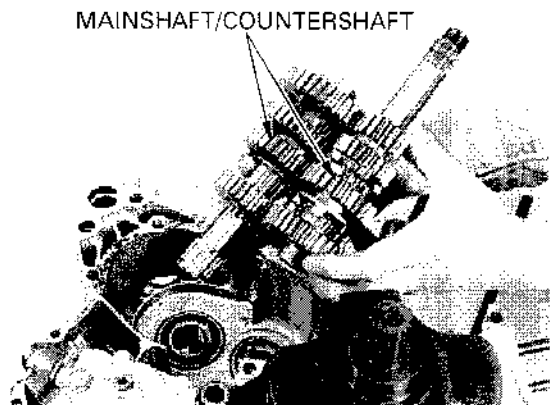

**DISASSEMBLY**

**NOTE:**

- Keep track of the disassembled parts (gears, bushings, washers, and snap rings) by stacking them on a tool or slipping them onto a piece of wire.
- Do not expand the snap ring more than necessary for removal. To remove a snap ring, expand the snap ring and pull it off using the gear behind it.

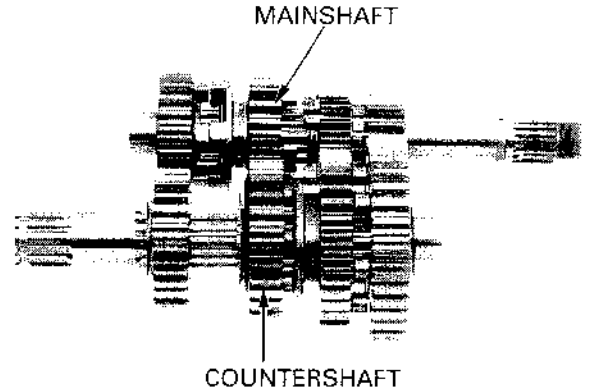

Disassemble the mainshaft and countershaft.

**INSPECTION**

**GEAR**

Check the gear dogs, dog holders and teeth for damage or excessive wear.  
Measure the I.D. of each gears.

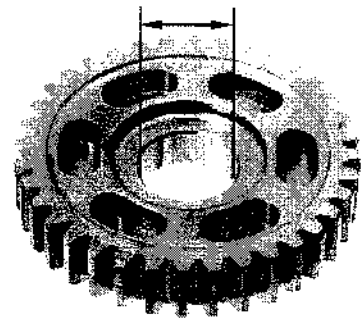

**SERVICE LIMITS:**

- M2, M4, C3:** 28.04 mm (1.104 in)
- C1:** 24.94 mm (0.982 in)

**BUSHING**

Check the bushings for damage or excessive wear.  
Measure the O.D. of each bushings.

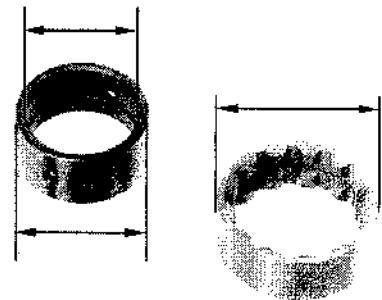

**SERVICE LIMITS:**

- M2, M4, C3:** 27.94 mm (1.100 in)
- C1:** 23.94 mm (0.943 in)

Measure the I.D. of each bushings.

**SERVICE LIMITS:**

- M2:** 25.04 mm (0.986 in)
- C1:** 20.06 mm (0.790 in)

**MAINSHAFT/COUNTERSHAFT**

Check the spline grooves and sliding surfaces for damage or abnormal wear.  
Measure the O.D. of the mainshaft and countershaft at the gear and bushing sliding areas.

**SERVICE LIMITS:**

- Mainshaft:**
- M2 gear bushing:** 24.94 mm (0.982 in)
- Countershaft:**
- C1 gear bushing:** 19.96 mm (0.786 in)

Calculate the clearance by subtracting mainshaft and countershaft O.D. from gear bushing I.D..

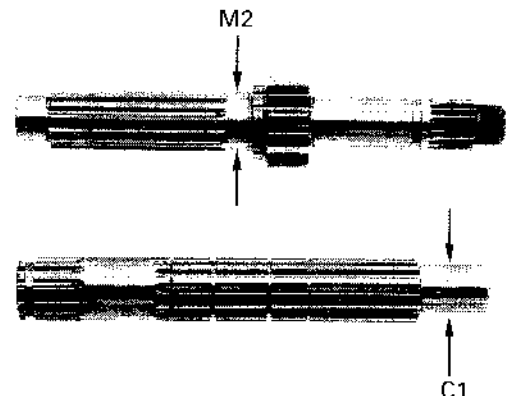

## CRANKSHAFT/TRANSMISSION

---

### SERVICE LIMITS:

M2, C1: 0.10 mm (0.004 in)

Calculate the clearance by subtracting gear bushing O.D. from gear I.D..

### SERVICE LIMITS:

M2, M4, C1, C3: 0.10 mm (0.004 in)

### SHIFT DRUM/SHIFT DRUM BEARING

Remove the dowel pin.

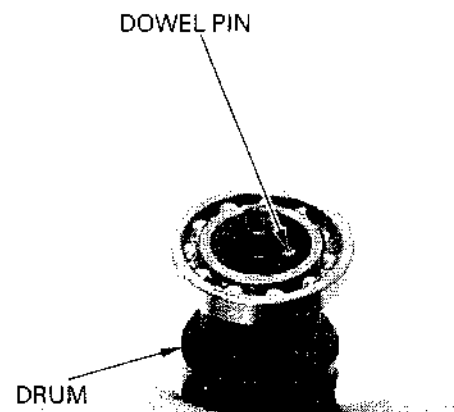

Inspect the shift drum for scoring, scratches or evidence of insufficient lubrication.  
Check the shift drum grooves for abnormal wear or damage.  
Turn the inner race of bearing with your finger. The bearing should turn smoothly and quietly.

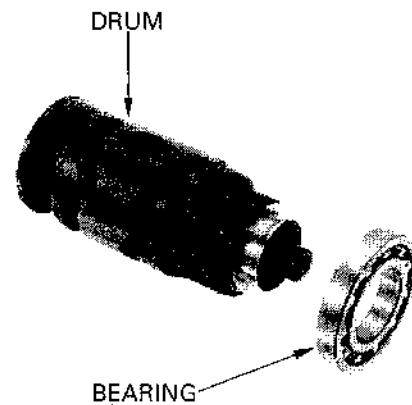

Measure the shift drum shaft O.D. at the left side journal.

**SERVICE LIMIT:** 11.94 mm (0.470 in)

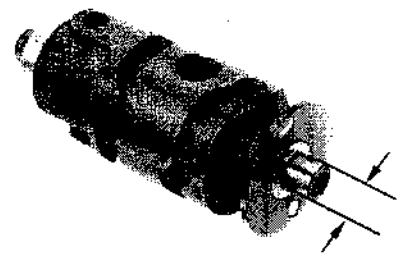

Install the dowel pin into the shift drum.

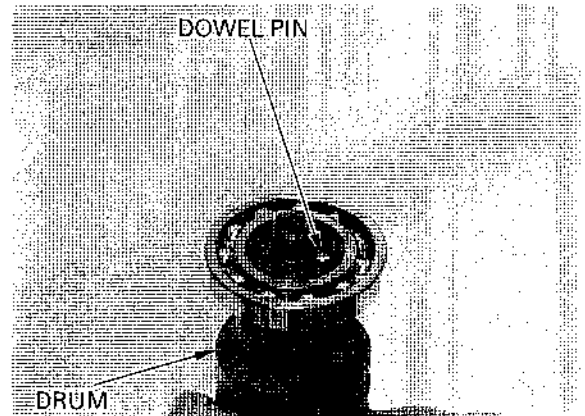

### SHIFT FORK, SHIFT FORK SHAFT

Check for abnormal wear or deformation.  
Measure the shift fork I.D. and claw thickness.

#### SERVICE LIMITS:

I.D. : 13.04 mm (0.513 in)

Claw thickness: 5.6 mm (0.22 in)

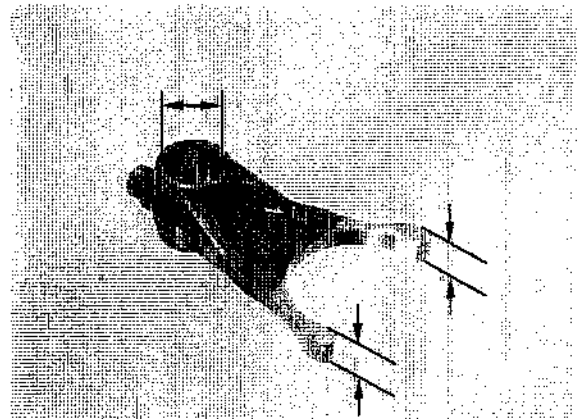

Check for abnormal wear, damage or straightness.  
Measure the shift fork shaft O.D..

SERVICE LIMIT: 12.90 mm (0.508 in)

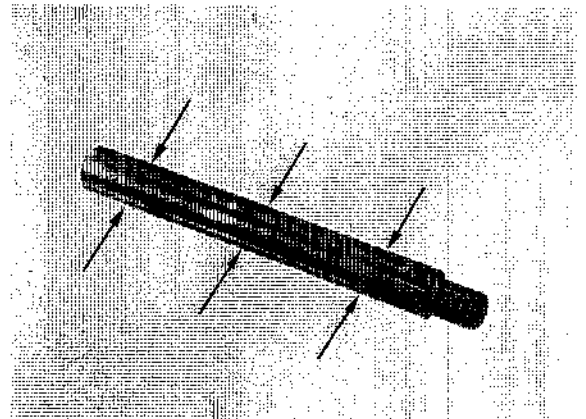

### SHIFT DRUM JOURNAL, SHIFT FORK SHAFT JOURNAL

Check the right and left crankcase shift fork shaft journal for wear or damage.  
Check the left crankcase shift drum journal for wear or damage.

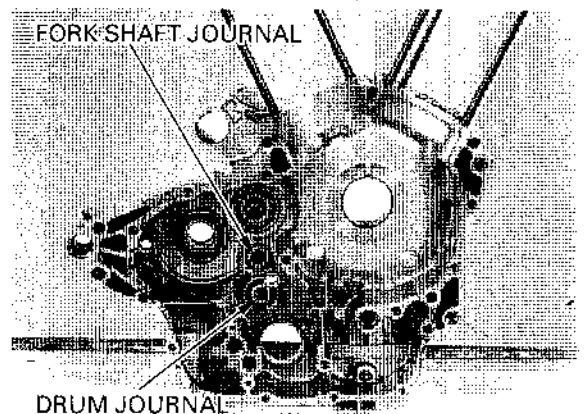

## CRANKSHAFT/TRANSMISSION

---

### OIL JET

Remove the oil jets from the front cylinder bore of the right and left crankcase.

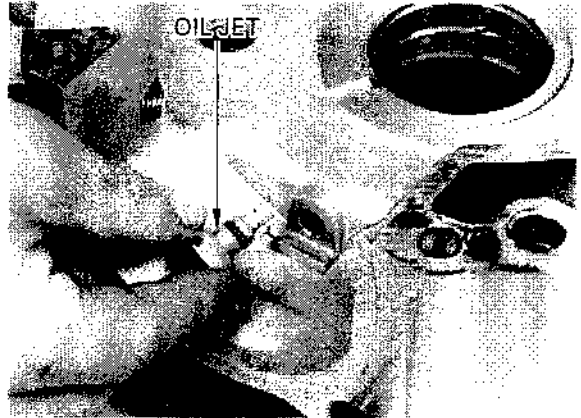

Check the O-ring for fatigue and damage.

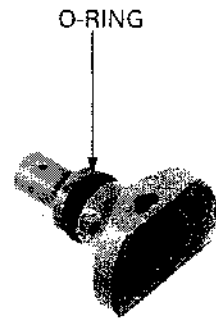

**ASSEMBLY**

Clean all parts in solvent.  
 Apply molybdenum oil solution to the gear and bushing sliding surface and shift fork grooves to ensure initial lubrication.  
 Assemble all parts into their original positions.

**NOTE:**

- Check the gears for freedom of movement or rotation on the shaft.
- Install the washers and snap rings with the chamfered edges facing the thrust load side.
- Do not reuse worn snap rings which could easily spin in the grooves.
- Check that the snap rings are seated in the grooves. Align their end gaps with the grooves of the spline.

**MAINSHAFT**

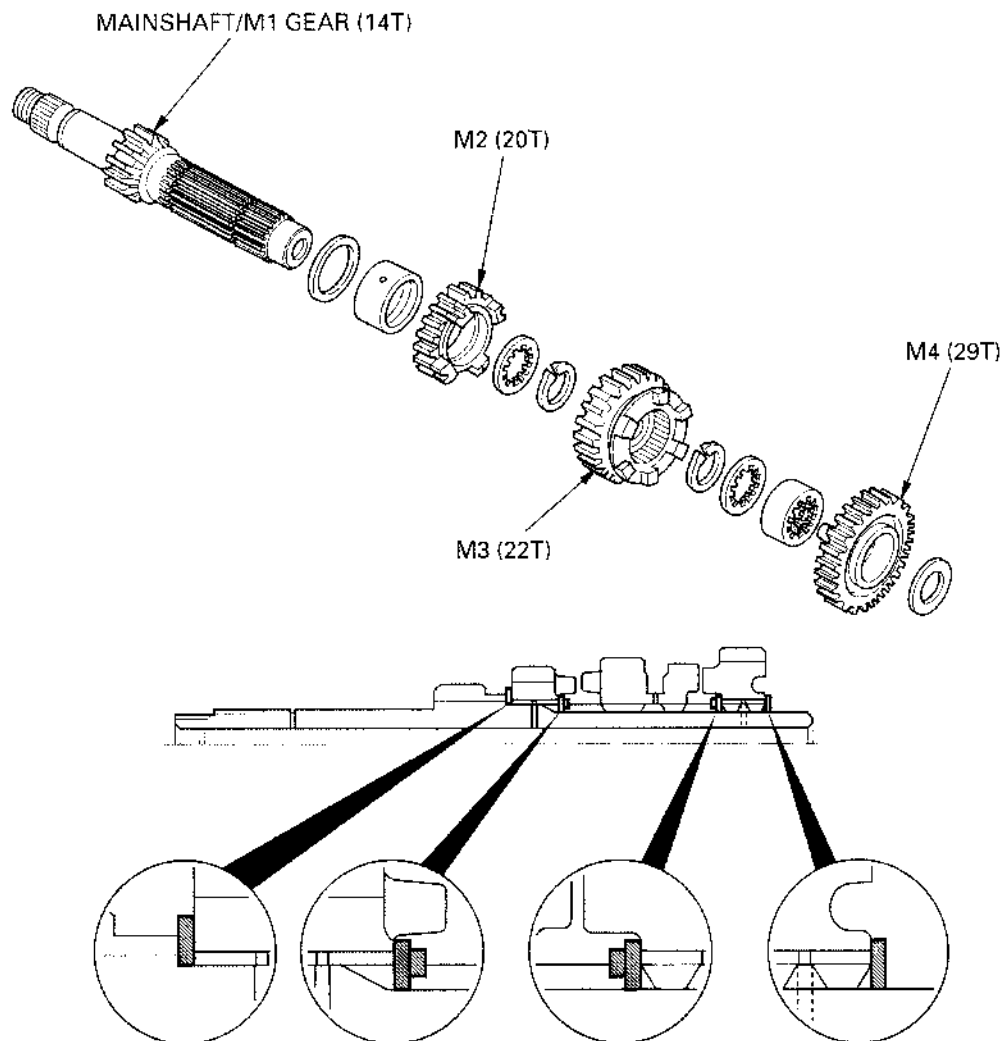

# CRANKSHAFT/TRANSMISSION

## COUNTERSHAFT

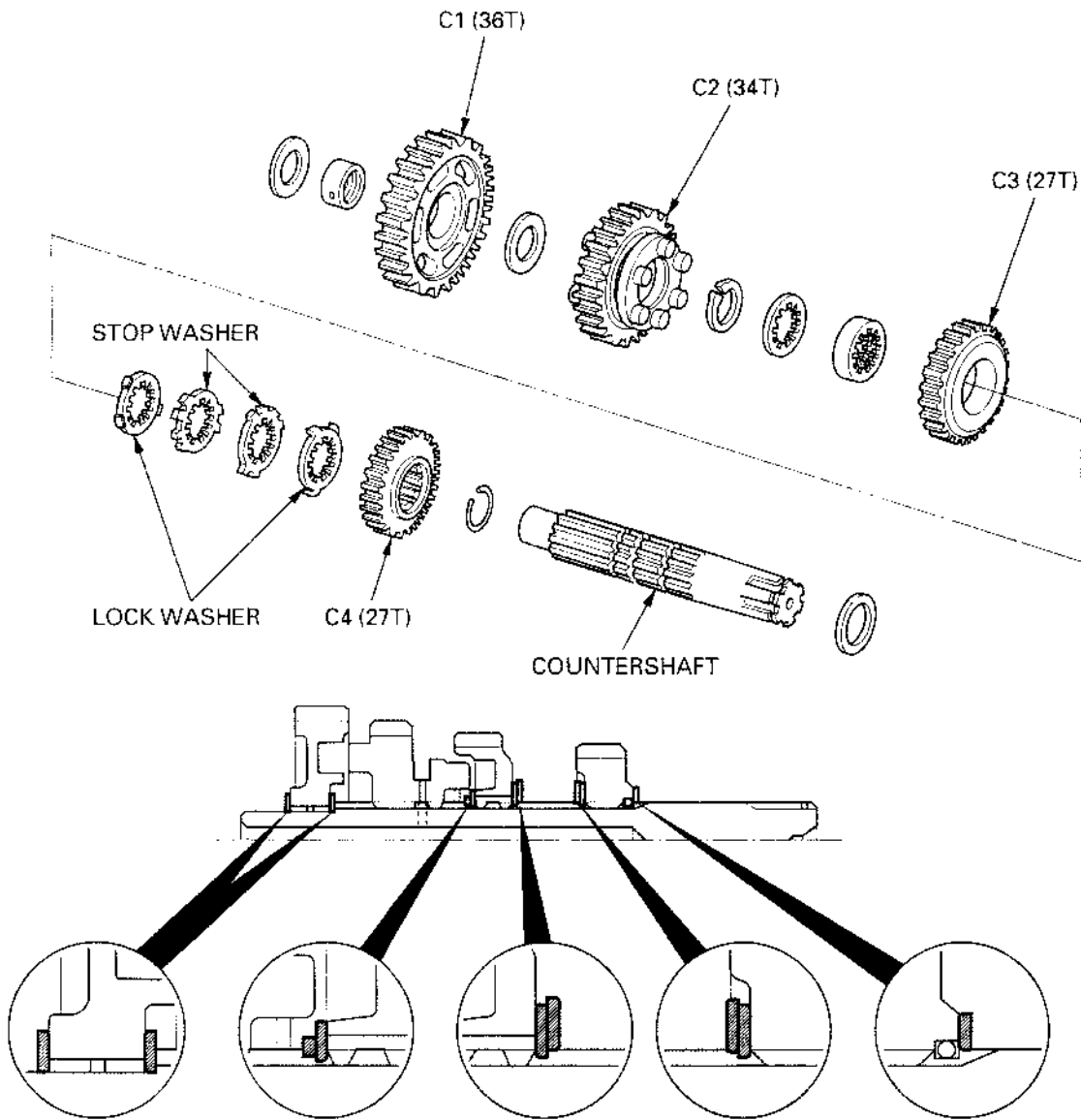

### INSTALLATION

Install the C4 gear onto the countershaft.

Install the lock washer and stop washer, aligning bigger tabs of the lock washer with bigger grooves of the stop washer in the countershaft groove.

Turn the washers as shown to lock them on the nearest spline.

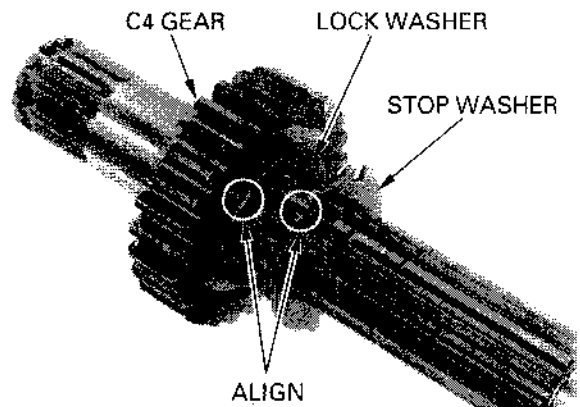



Install the stopper ring onto the countershaft.

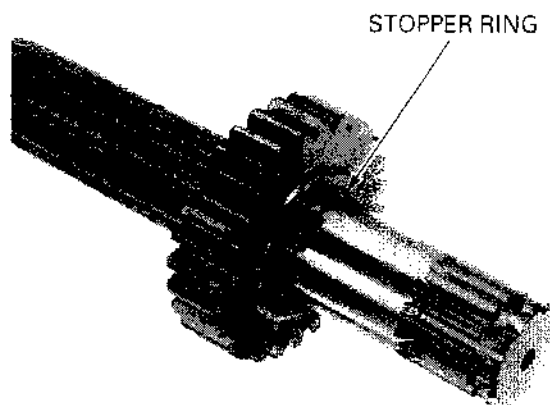

Install the stop washer first, and then the lock washer for the C3 gear. Align and lock the washers using the procedure above.

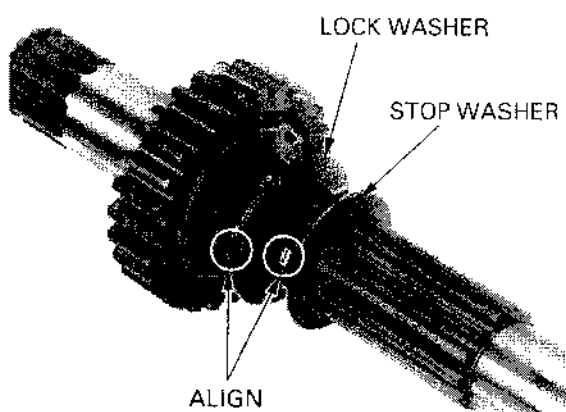

Assemble the countershaft and mainshaft.

Check the gears for freedom of movement or rotation on the shaft.

Check that the snap rings are seated in the grooves and align their end gaps with the lands of the splines.

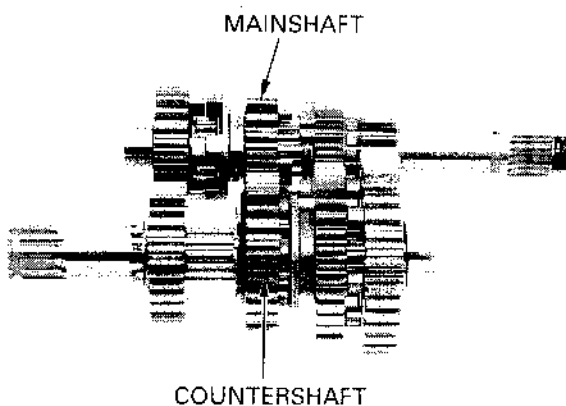

Apply engine oil to the following parts.

- Mainshaft
- Countershaft
- Each gears
- Mainshaft bearing
- Countershaft bearing
- Shift drum bearing

Install the mainshaft and countershaft to the left crankcase as assembly.

**NOTE:**

- Do not forget to install the transmission end washer.
- When mainshaft and countershaft installation, be careful not to damage the countershaft oil seal.

MAINSHAFT/COUNTERSHAFT



## CRANKSHAFT/TRANSMISSION

### NOTE:

Each shift forks has an identification mark; "R" is for the right shift fork and "C" is for the center shift fork.

Install the shift forks to the grooves of the shifter gear with their marks facing up (right crankcase side).

Install the shift drum aligning the guide pins on the shift forks with the guide grooves of the shift drum.

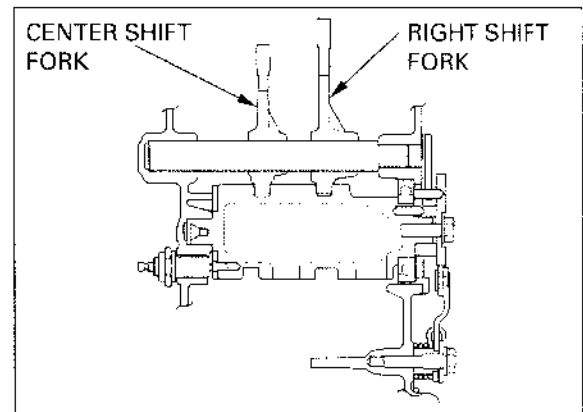
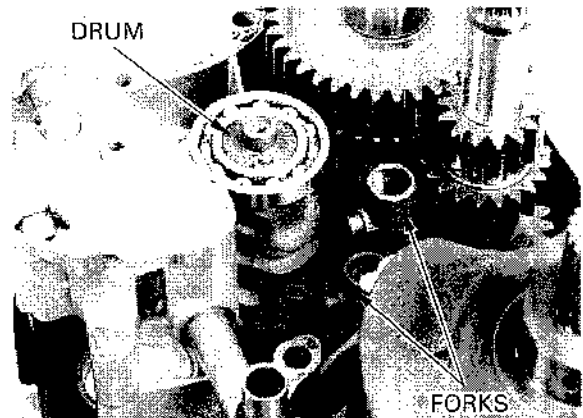
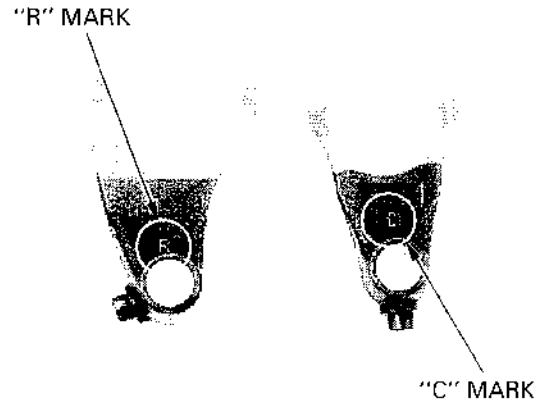

Apply molybdenum oil solution to the shift fork shaft.

Install the shift fork shaft with its stepped end side facing up (right crankcase side).

After installing, check for smooth transmission operation.

Assemble the crankcase (page 12-25).

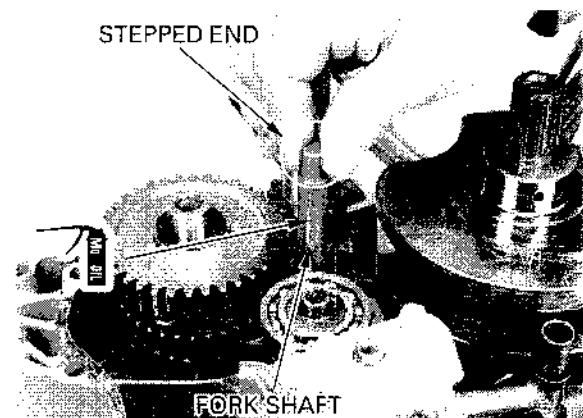

## CRANKCASE BEARING REPLACEMENT

Remove the followings:

- Crankshaft (page 12-6).
- Transmission (page 12-14).
- Oil pump (page 4-4).

Turn the inner race of each bearing with your finger. The bearings should turn smoothly and quietly. Also check that the bearing outer race fits tightly in the crankcase.

Replace the bearings if the races does not turn smoothly and quietly, or if they fit loosely in the crankcase.

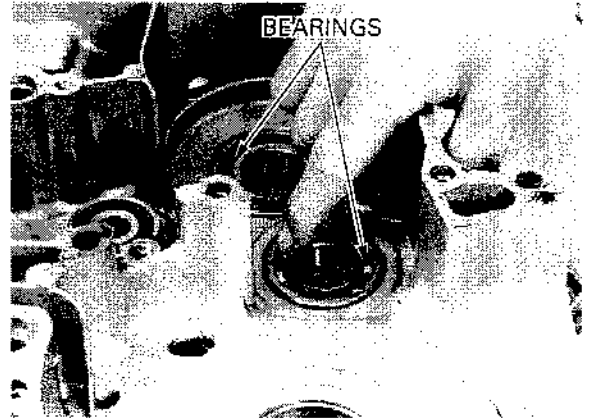

### LEFT CRANKCASE BEARING REPLACEMENT

**NOTE:**

The oil pump must be removed before replacing the crankcase bearing.

Remove the left mainshaft bearing using the special tools.

**TOOLS:**

- |                            |                                   |
|----------------------------|-----------------------------------|
| <b>Bearing remover set</b> | 07936-3710001                     |
|                            | Not available in U. S. A.         |
| - Remover handle           | 07936-3710100                     |
| - Bearing remover head     | 07936-3710600                     |
| - Remover sliding weight   | 07741-0010201 or<br>07936-3710200 |

Remove the mainshaft bearing oil guide plate.

Remove the left countershaft bearing and oil seal.

Install the mainshaft bearing oil guide plate.

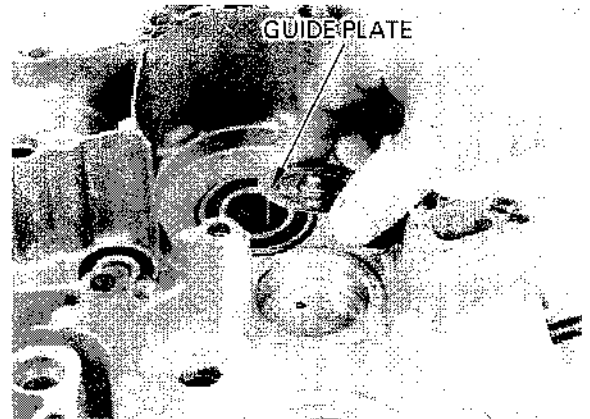
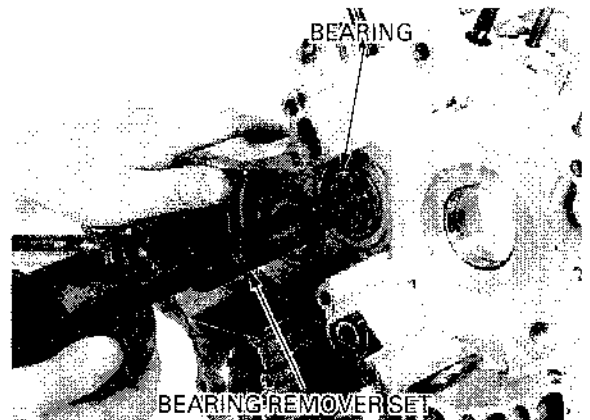

*Drive in the new bearing squarely with the marking side facing up.*

Install the new bearings to the left crankcase using the following special tools.

**TOOLS:**

**Mainshaft bearing:**

- |                               |               |
|-------------------------------|---------------|
| <b>Driver</b>                 | 07749-0010000 |
| <b>Attachment, 42 × 47 mm</b> | 07746-0010300 |

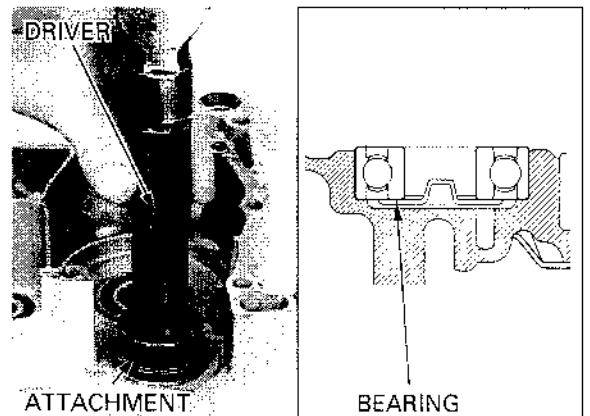

## CRANKSHAFT/TRANSMISSION

### TOOLS:

#### Countershaft bearing:

Driver	07749-0010000
Attachment, 52 × 55 mm	07746-0010400
Pilot, 25 mm	07746-0040600

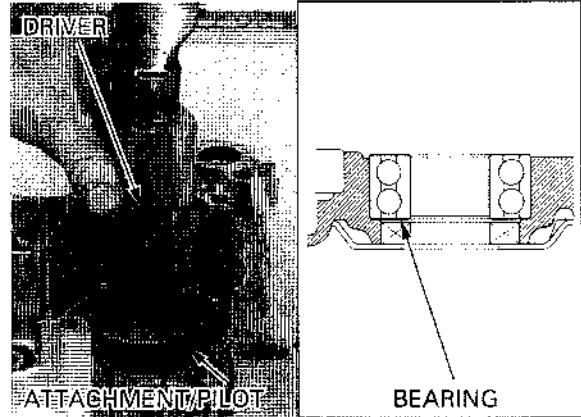

Apply the grease to the new countershaft oil seal lip.

Install the new countershaft oil seal.

Check the gearshift spindle oil seal for damage.

Replace the gearshift spindle oil seal if necessary.



### RIGHT CRANKCASE BEARING REPLACEMENT

Drive out the right mainshaft bearing and right countershaft bearing.

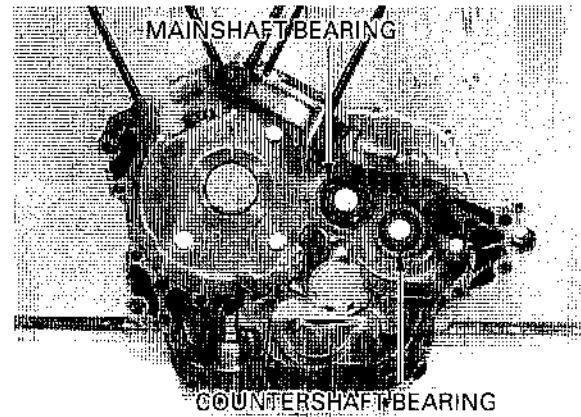

*Drive in the new bearings squarely with the marking side facing up.*

Install the new bearings to the right crankcase using the following special tools.

### TOOLS:

#### Mainshaft bearing:

Driver	07749-0010000
Attachment, 52 × 55 mm	07746-0010400
Pilot, 25 mm	07746-0040600

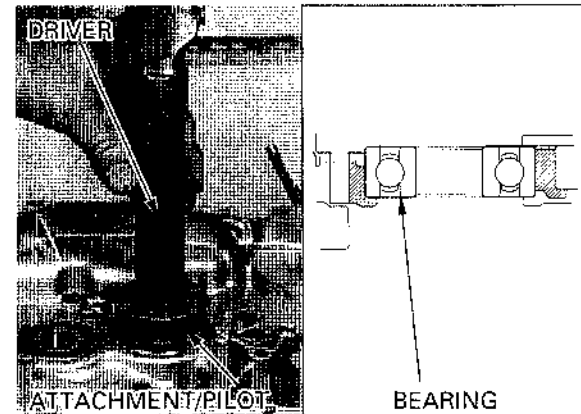

**TOOLS:**

**Countershaft bearing:**

<b>Driver</b>	07749-0010000
<b>Attachment, 42 × 47 mm</b>	07746-0010300
<b>Pilot, 20 mm</b>	07746-0040500

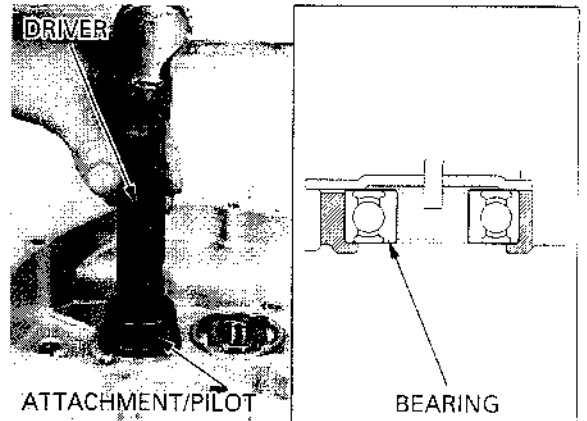

**CRANKCASE ASSEMBLY**

Clean the right and left crankcase mating surfaces thoroughly, being careful not to damage them.

Install the followings:

- Crankshaft (page 12-13)
- Transmission (page 12-20)
- Oil pump (page 4-9)

Install the dowel pins.

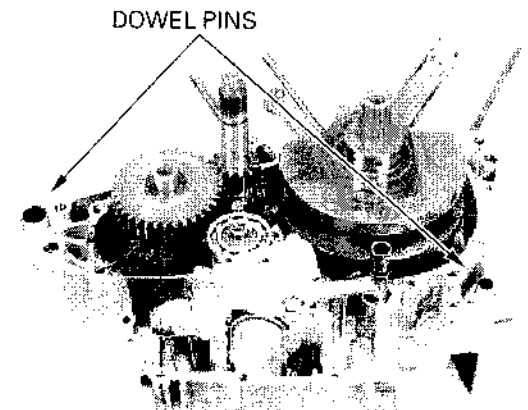

Apply a light but thorough coating of sealant to all crankcase mating surfaces except the oil passage area.

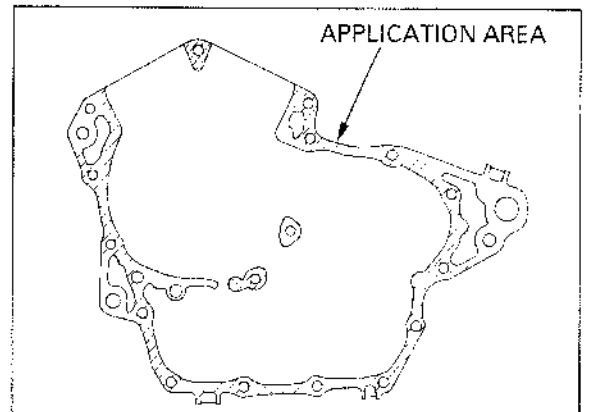

Install the right crankcase to the left crankcase.

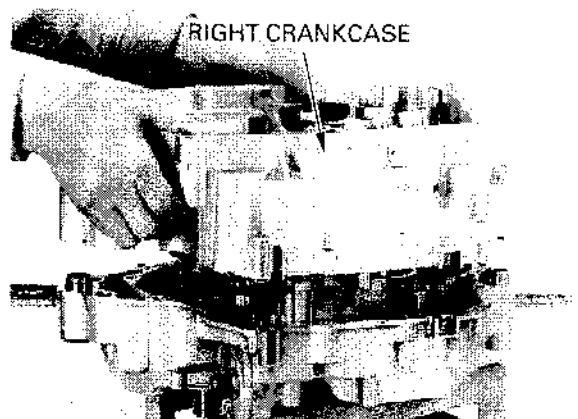

## CRANKSHAFT/TRANSMISSION

Install and tighten the right crankcase bolts in a crisscross pattern in several steps.

**TORQUE: 8 mm bolt:** 23 N·m (2.3 kgf·m , 17 lbf·ft)  
**6 mm bolt:** 9 N·m (0.9 kgf·m , 6.5 lbf·ft)

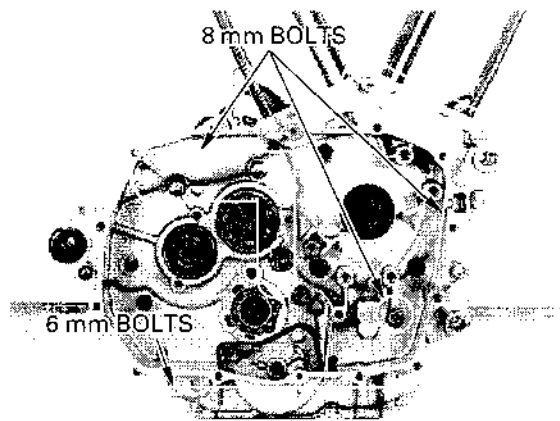

Install and tighten the left crankcase bolts in a crisscross pattern in several steps.

**TORQUE: 8 mm bolt:** 23 N·m (2.3 kgf·m , 17 lbf·ft)  
**6 mm bolt:** 9 N·m (0.9 kgf·m , 6.5 lbf·ft)

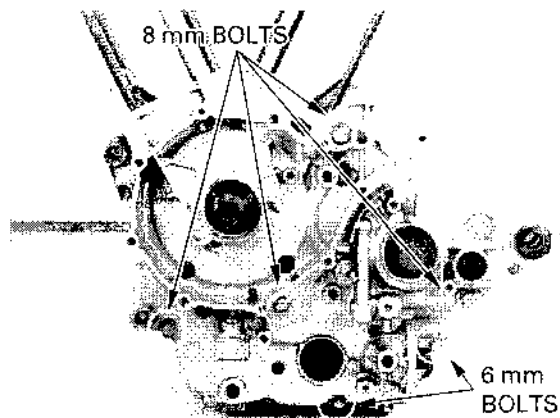

Clean and apply a locking agent to the gearshift cam plate bolt threads.

*Install the gearshift cam plate by aligning the hole on the cam plate with the dowel pin.*

Install the gearshift cam plate and bolt to the shift drum.

Tighten the bolt to the specified torque.

**TORQUE:** 12 N·m (1.2 kgf·m , 9 lbf·ft)

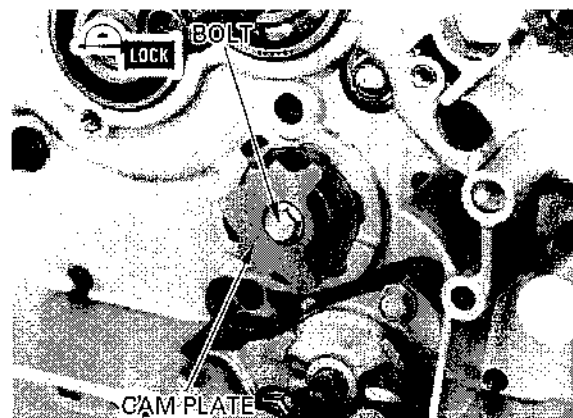

Clean and apply a locking agent to the mainshaft bearing set plate bolt threads.

Install the mainshaft bearing set plate.

Install and tighten the mainshaft bearing set plate bolts to the specified torque.

**TORQUE:** 12 N·m (1.2 kgf·m , 9 lbf·ft)

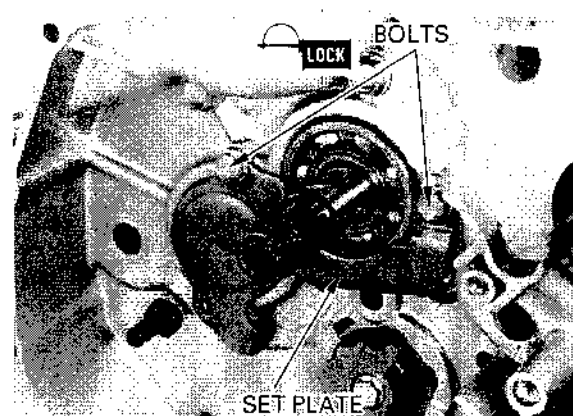

Clean and apply a locking agent to the rear cam chain tensioner set plate bolt threads.  
Install the rear cam chain tensioner set plate.  
Install and tighten the rear cam chain tensioner set plate bolt to the specified torque.

**TORQUE:** 12 N·m (1.2 kgf·m , 9 lbf·ft)

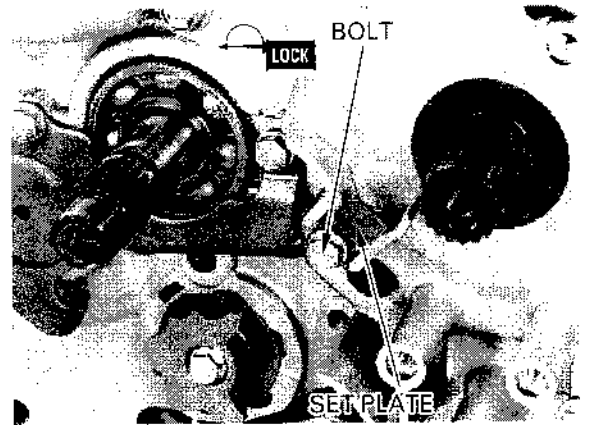

Install the rear cam chain drive sprocket to the crankshaft, aligning the extra wide splines in the sprocket and crankshaft.

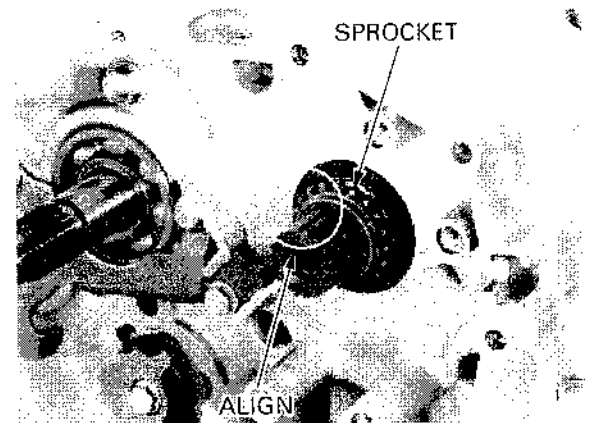

Install the rear cam chain to the cam chain drive sprocket tooth.

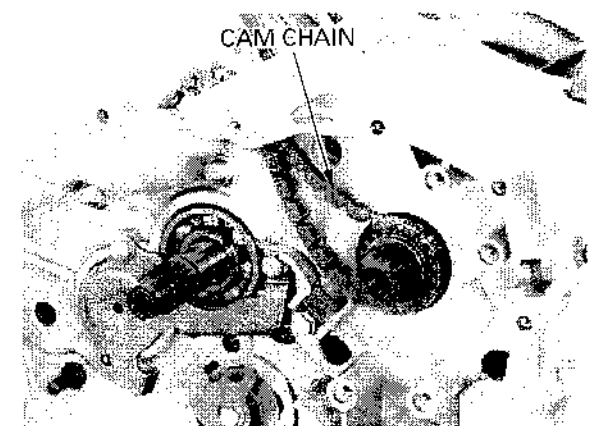

Install the front cam chain to the cam chain drive sprocket tooth.  
Clean and apply a locking agent to the front cam chain tensioner set plate bolt threads.  
Install the front cam chain tensioner set plate.  
Install and tighten the front cam chain tensioner set plate bolt to the specified torque.

**TORQUE:** 12 N·m (1.2 kgf·m , 9 lbf·ft)

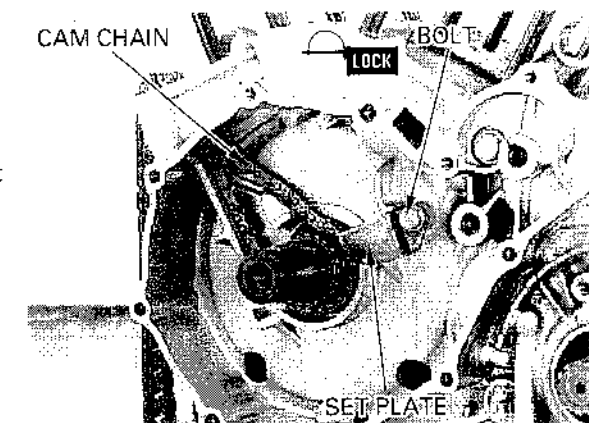

## CRANKSHAFT/TRANSMISSION

---

Install the engine sub harness.

**NOTE:**

Route the engine sub harness correctly (page 1-28).

Clean and apply a locking agent to the countershaft set plate bolt threads.

Install the countershaft bearing set plate and bolts. Tighten the countershaft bearing set plate bolts to specified torque.

**TORQUE:** 9 N·m (0.9 kgf·m , 6.5 lbf·ft)

Install the engine to the frame (Section 7).

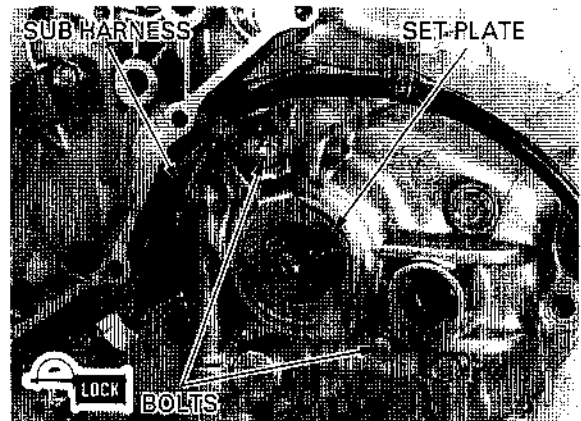



---

**MEMO**

---

# FRONT WHEEL/SUSPENSION/STEERING

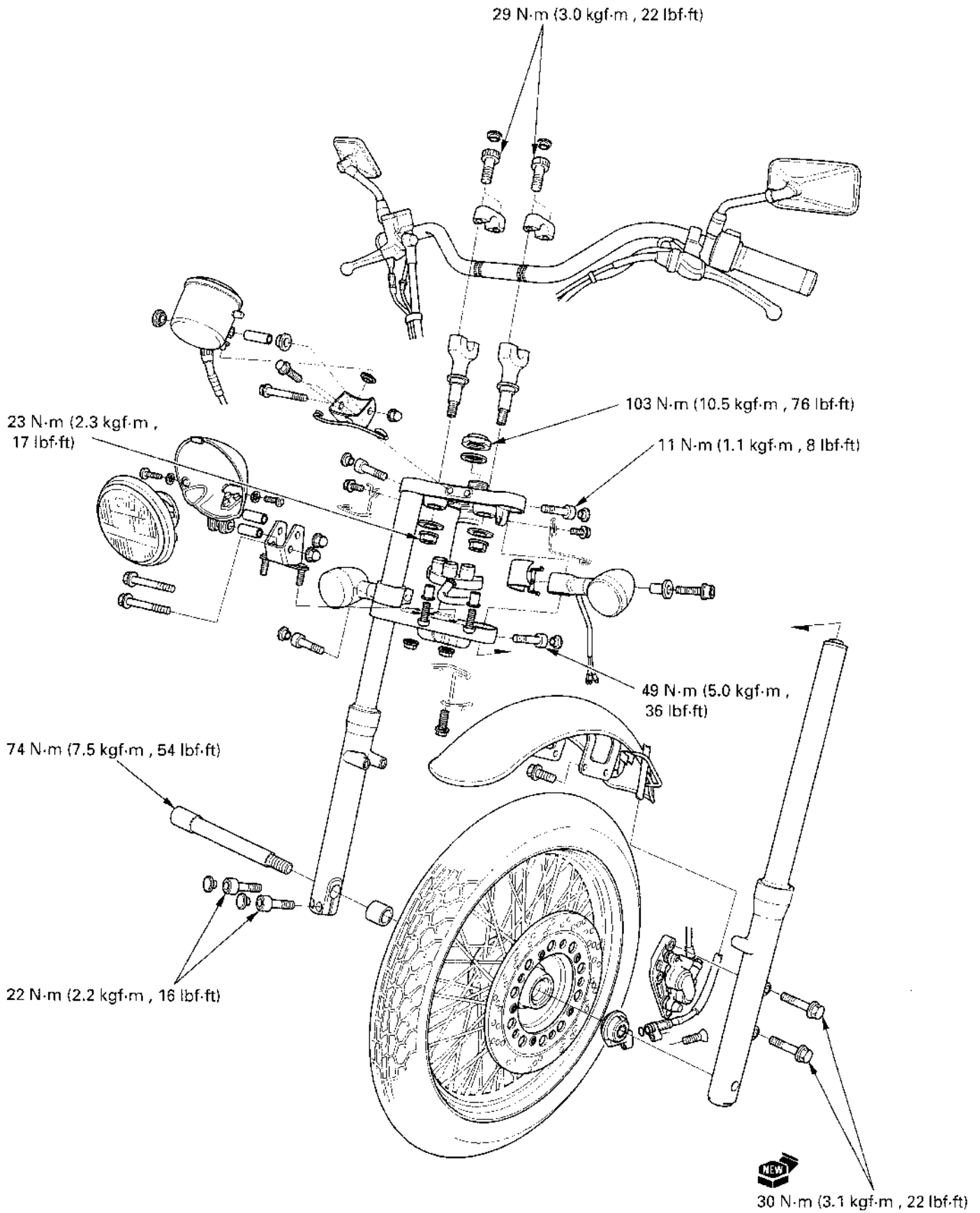

# 13. FRONT WHEEL/SUSPENSION/STEERING

SERVICE INFORMATION	13-1	FRONT WHEEL	13-13
TROUBLESHOOTING	13-3	FORK	13-22
HANDLEBAR	13-4	STEERING STEM	13-34

## SERVICE INFORMATION

### GENERAL

#### ▲WARNING

- A contaminated brake disc or pad reduces stopping power. Discard contaminated pads and clean a contaminated disc with a high quality brake degreasing agent.
- Riding on damaged rims or spokes impairs safe operation of the vehicle.
- Wheel balance directly affects the stability, handling and overall safety of the motorcycle. Carefully check balance before reinstalling the wheel.

#### CAUTION:

- Do not jack up the motorcycle using oil filter.
- To avoid damaging the rim when using the tire lever, always use rim protectors.

- When servicing the front wheel, support the motorcycle securely with a jack or other support under the engine.
- Do not operate the brake lever after removing the caliper and front wheel. To do so will cause difficulty in fitting the brake disc between the brake pads.
- Refer to Section 15 for brake system information.

## SPECIFICATIONS

Unit: mm (in)

ITEM		STANDARD	SERVICE LIMIT
Minimum tire thread depth			1.5 (0.06)
Cold tire pressure	Up to 90 kg (200 lb) load	200 kPa (2.00 kgf/cm <sup>2</sup> , 29 psi)	
	Up to maximum weight capacity	200 kPa (2.00 kgf/cm <sup>2</sup> , 29 psi)	
Axle runout			0.20 (0.008)
Wheel rim runout	Radial		2.0 (0.08)
	Axial		2.0 (0.08)
Wheel hub-to-rim distance		32.3 ± 0.8 (1.27 ± 0.03)	
Wheel balance weight		Max 70 g (2.5 oz)	
Fork	Spring free length	333.9 (13.15)	327.2 (12.88)
	Spring installed direction	Tightly wound coils should be at the top	
	Tube runout		0.20 (0.008)
	Recommended fork oil	Pro-Honda Suspension Fluid SS-8	
	Oil level	111 (4.4)	
	Oil capacity	449 ± 0.25 cm <sup>3</sup> (15.2 ± 0.02 US oz, 15.8 ± 0.09 Imp oz)	
Steering head bearing preload		0.9 – 1.4 kgf (2.0 – 3.1 lbs)	

## FRONT WHEEL/SUSPENSION/STEERING

### TORQUE VALUES

Steering stem nut	103 N·m (10.5 kgf·m , 76 lbf·ft)	See page 13-40
Top thread A		
Top thread B		
Fork top bridge pinch bolt	11 N·m (1.1 kgf·m , 8 lbf·ft)	
Fork bottom bridge pinch bolt	49 N·m (5.0 kgf·m , 36 lbf·ft)	
Handlebar upper holder bolt	29 N·m (3.0 kgf·m , 22 lbf·ft)	
Handlebar lower holder nut	23 N·m (2.3 kgf·m , 17 lbf·ft)	
Handlebar switch screw	4 N·m (0.4 kgf·m , 2.9 lbf·ft)	
Front axle	74 N·m (7.5 kgf·m , 54 lbf·ft)	
Front axle pinch bolt	22 N·m (2.2 kgf·m , 16 lbf·ft)	
Front brake disc mounting bolt	'97-'98: 39 N·m (4.0 kgf·m , 29 lbf·ft) After '98: 42 N·m (4.3 kgf·m , 31 lbf·ft)	ALOC bolt: with a new one
Fork cap	23 N·m (2.3 kgf·m , 17 lbf·ft)	
Fork socket bolt	29 N·m (3.0 kgf·m , 22 lbf·ft)	Apply a locking agent to the threads
Clutch lever holder bolt	12 N·m (1.2 kgf·m , 9 lbf·ft)	
Brake master cylinder holder bolt	12 N·m (1.2 kgf·m , 9 lbf·ft)	
Spokes	4 N·m (0.4 kgf·m , 2.9 lbf·ft)	

### TOOLS

Attachment, 42 × 47 mm	07746-0010300	
Attachment, 52 × 55 mm	07746-0010400	
Pilot, 20 mm	07746-0040500	
Bearing remover shaft	07746-0050100	
Bearing remover head, 20 mm	07746-0050600	
Driver	07749-0010000	
Steering stem socket	07916-3710101	
Bottom holder pipe	07930-KA50000	Not available in U.S.A.
—Holder handle	07930-KA40200	Equivalent commercially available in U.S.A.
—Bottom holder attachment	07930-KA50100	
Bearing race remover	07946-3710500	
Steering stem driver	07946-MB00000	
Fork seal driver, 39 mm	07947-4630100	
Ball race remover	07953-MJ10000	Not available in U.S.A.
—Driver attachment	07953-MJ10100	or 07953-MJ1000A or 07953-MJ1000B
—Driver handle	07953-MJ10200	07949-3710001 or 07746-0010100
Spoke wrench	07JMA-MR60100	or equivalent commercially available in U.S.A.

## **TROUBLESHOOTING**

### **Hard steering**

- Steering top thread too tight
- Faulty steering head bearings
- Damaged steering head bearings
- Faulty tire
- Insufficient tire pressure

### **Steers to one side or does not track straight**

- Bent fork
- Faulty steering head bearings
- Damaged steering head bearings
- Bent frame
- Worn wheel bearings
- Bent front axle
- Worn swingarm pivot component

### **Front wheel wobbling**

- Bent rim
- Worn wheel bearings
- Faulty tire
- Unbalanced tire and wheel

### **Soft suspension**

- Weak fork spring
- Low fluid level in fork
- Insufficient fluid in fork
- Low tire pressure

### **Hard suspension**

- High tire pressure
- Bent fork
- High fluid level in fork
- Incorrect fluid weight
- Clogged fluid passage

### **Front suspension noisy**

- Loose fork fasteners
- Insufficient fluid in fork

### **Wheel turns hard**

- Faulty wheel bearings
- Bent front axle
- Brake drag
- Faulty speedometer gear

## HANDLEBAR

### GRIP REPLACEMENT

Remove the throttle grip from the handlebar (page 13-6).

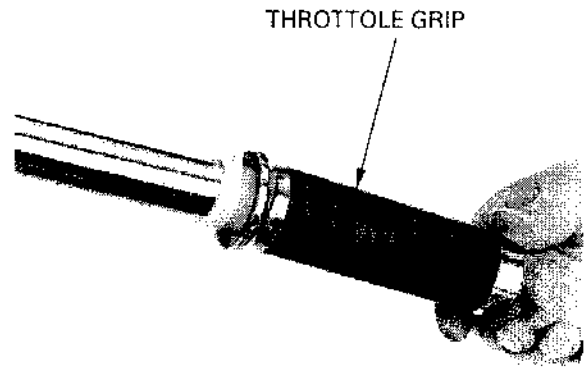

Remove the grip from the throttle pipe.

Apply Honda Bond A or Honda Grip Cement (U.S.A. only) to the inside surface of the throttle grip to the clean surface of the throttle pipe. Wait 3-5 minutes and install the grip. Rotate the grip for even application of the adhesive.

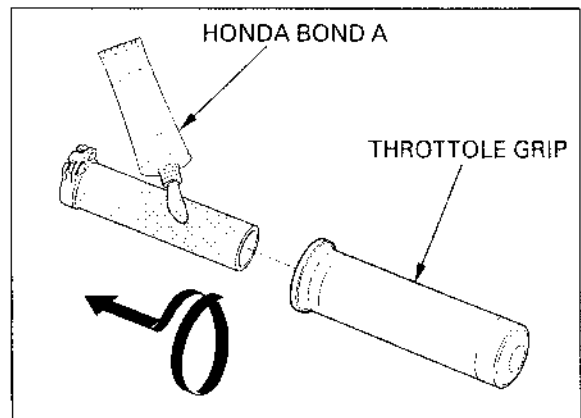

Install the throttle grip to the handlebar (page 13-10).

Remove the left handlebar grip from the handlebar.

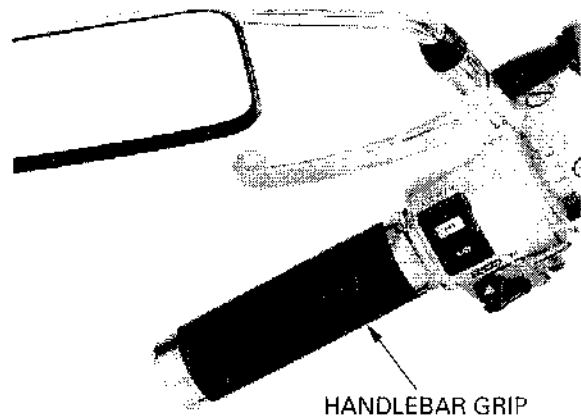

Apply Honda Bond A or Honda Grip Cement (U.S.A. only) to the inside surface of the left handle grip to the clean surface of the handlebar. Wait 3-5 minutes and install the grip. Rotate the grip for even application of the adhesive.

**NOTE:**

Allow the adhesive to dry for an hour before using. Check for smooth throttle operation after the throttle grip is installed.

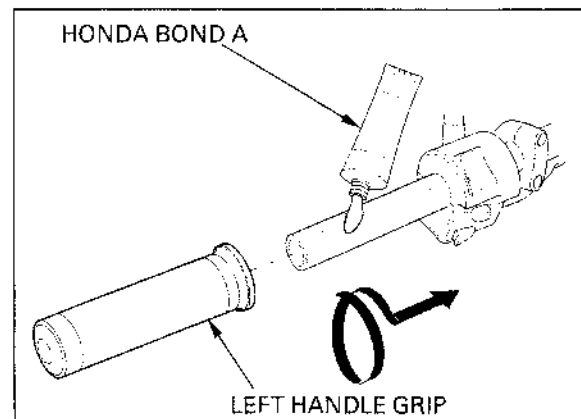

**REMOVAL**

Remove the right and left rearview mirrors.

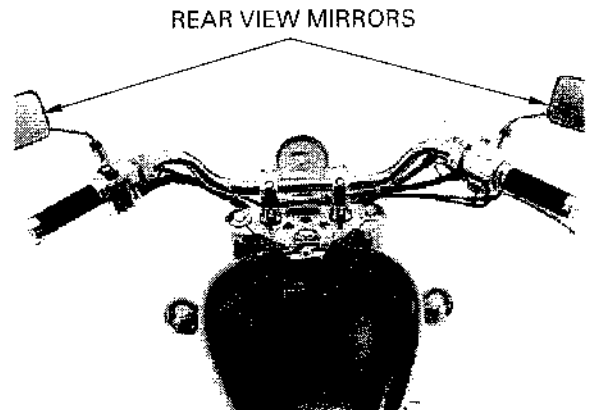

Loosen the clutch cable lower and upper adjusting nuts, and disconnect the clutch cable from the clutch lever. Remove the bolt/nut and clutch lever from the clutch lever bracket.

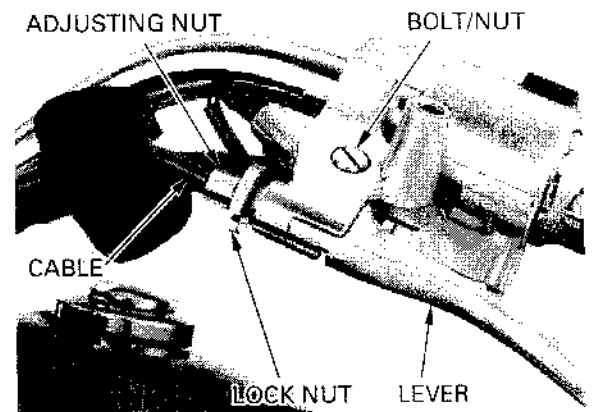

Disconnect the clutch switch connectors from the clutch switch.

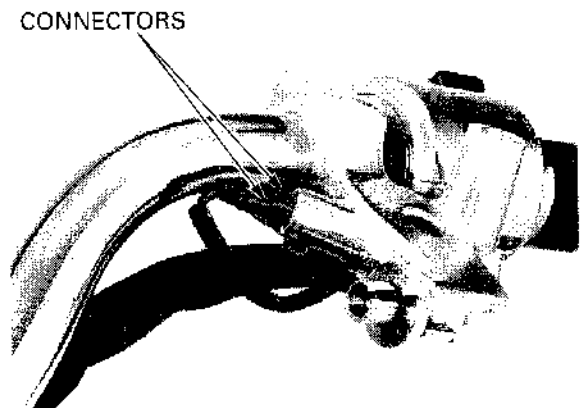

Remove the socket bolts, clutch lever holder and bracket.

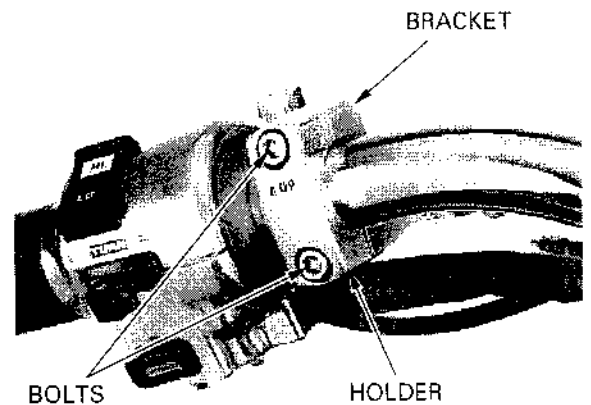

## FRONT WHEEL/SUSPENSION/STEERING

---

Remove the clutch switch from the clutch holder.

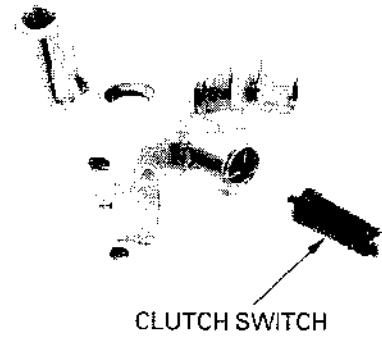

Remove the screws and left handlebar switch.

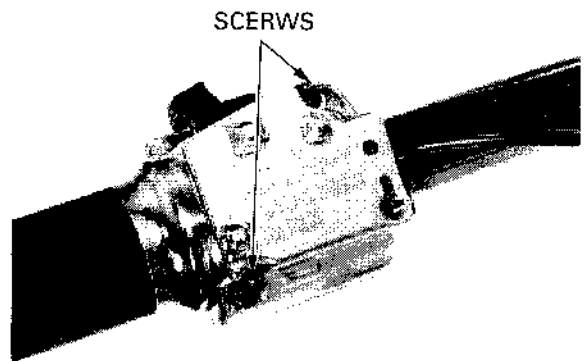

Remove the left handlebar grip and adapter.

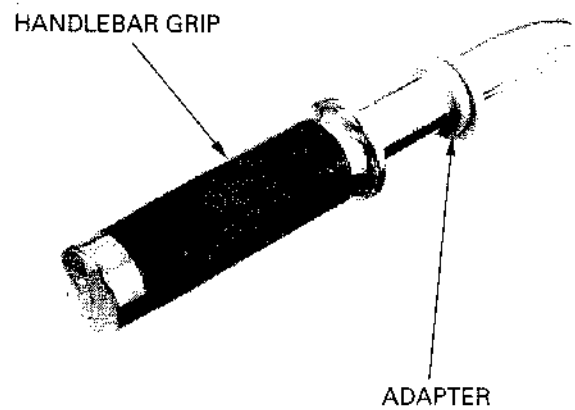

Disconnect the front brake light switch connectors from the switch.

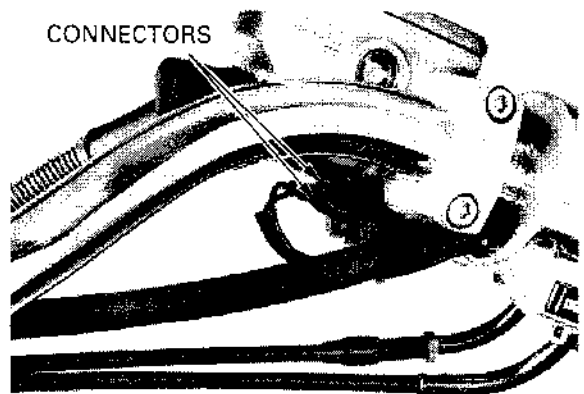



Remove the socket bolts, master cylinder holder and master cylinder.

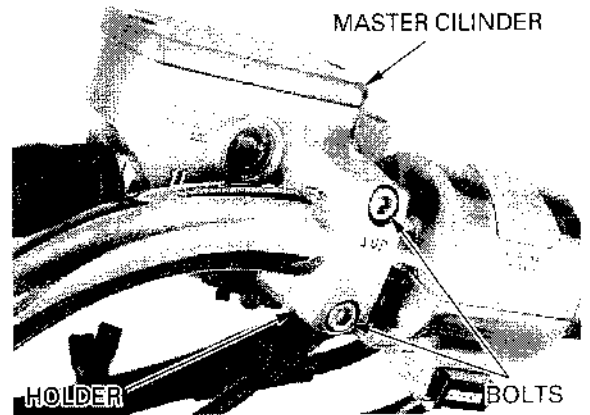

Remove the right handlebar switch screws.

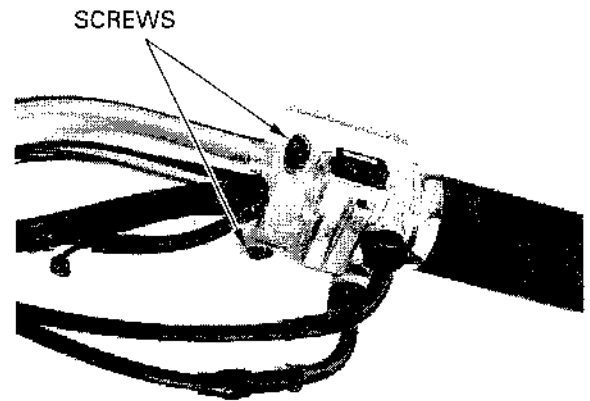

Loosen the throttle cable lower adjusting nuts at the carburetors and disconnect the throttle cables from the throttle cable guide.

Remove the right handlebar switch from the handlebar.

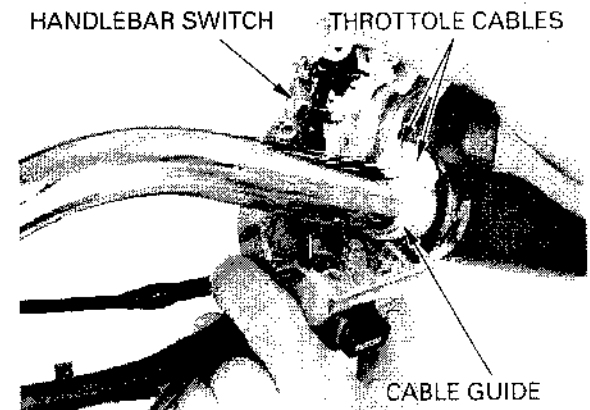

Remove the throttle grip from the handlebar.

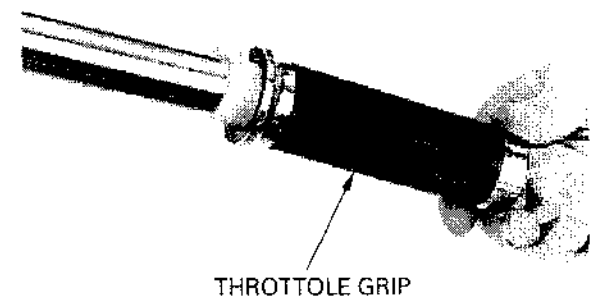

## FRONT WHEEL/SUSPENSION/STEERING

*If the handlebar lower holders will be removed, loosen the lower holder nuts before removing the upper holders.*

Loosen the handlebar lower holder nuts.

**NOTE:**

Do not remove the lower holder nuts yet.

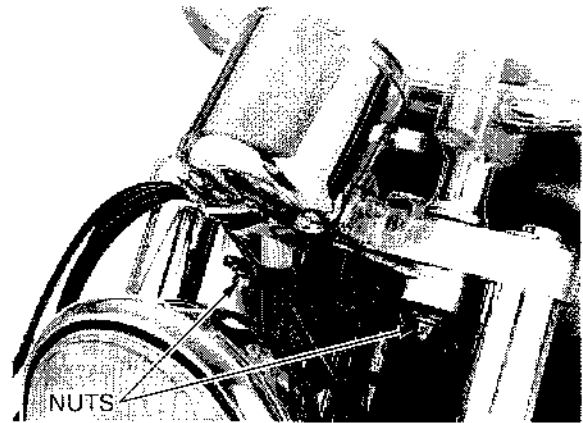

Remove the handlebar upper holder bolt caps.

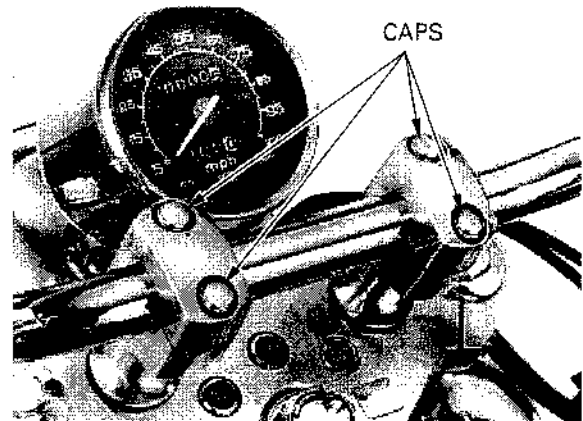

Remove the socket bolts, upper holders and handlebar.

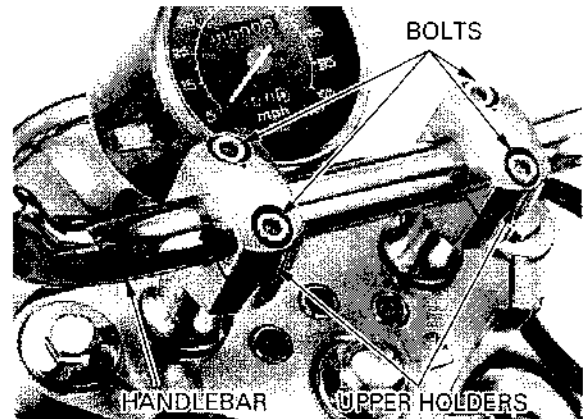

Remove the nuts, washers and handlebar lower holders.

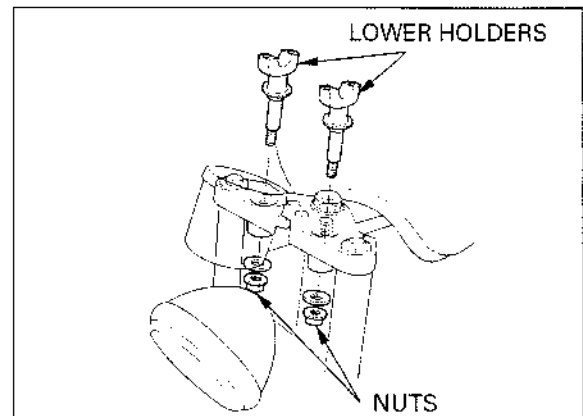

Check the bushings for wear or damage.  
Replace the bushings if necessary.

### INSTALLATION

Install the handlebar lower holders, washers and nuts.

#### NOTE:

Do not tighten the lower holder nuts yet.

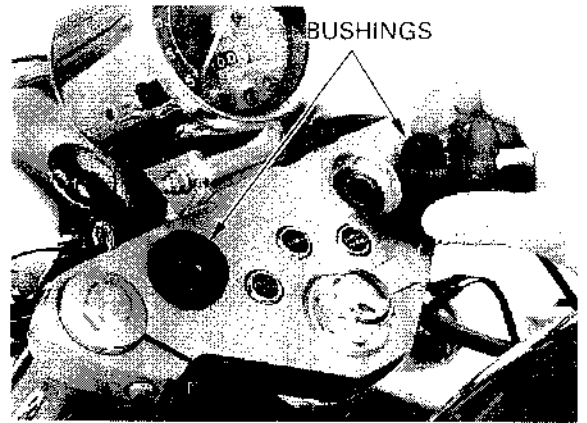

Install the handlebar and upper holders with their punch marks facing forward.

Temporarily tighten the upper holder socket bolts.

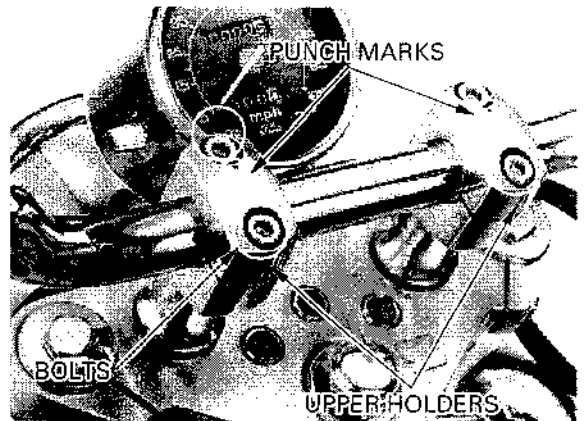

Tighten the lower holder nuts to the specified torque.

**TORQUE:** 23 N·m (2.3 kgf·m , 17 lbf·ft)

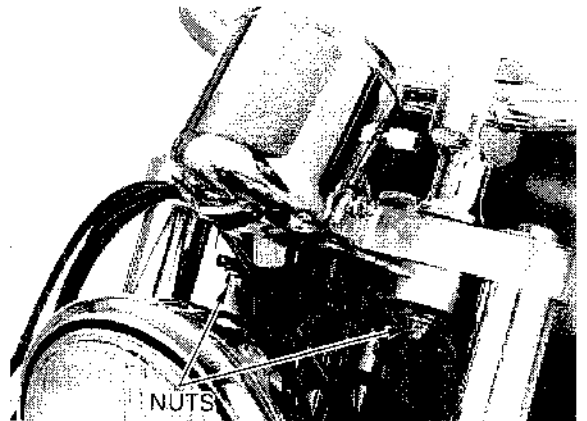

Loosen the upper holder socket bolts and align the punch marks on the handlebar with the splits of the handlebar holders.

Tighten the forward bolts first, then tighten the rear bolts.

**TORQUE:** 29 N·m (3.0 kgf·m , 22 lbf·ft)

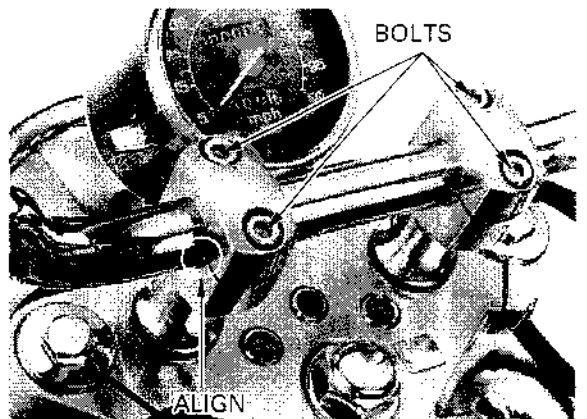

## FRONT WHEEL/SUSPENSION/STEERING

Install the upper holder bolt caps.

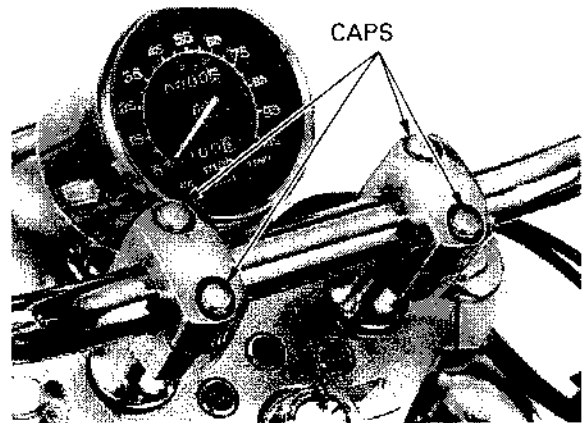

Apply grease to the throttle grip inner surface and throttle cable contact point.  
Install the throttle grip to the handlebar.

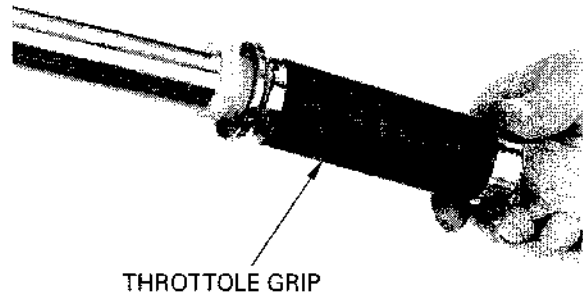

Connect the throttle cables to the throttle cable guide.

Install the right handlebar switch housing onto the handlebar, aligning the locating pin with the hole in the handlebar.

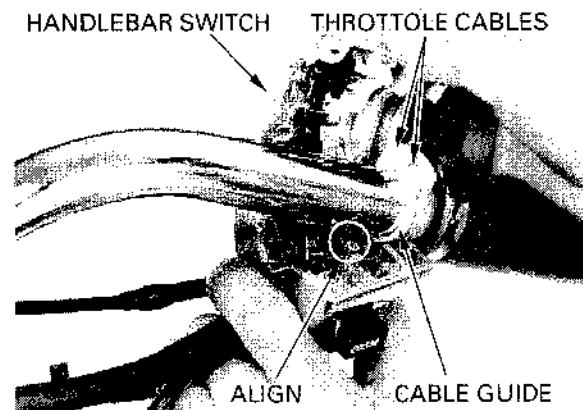

Install the attaching screws and tighten the forward screw first, then tighten the rear screw.

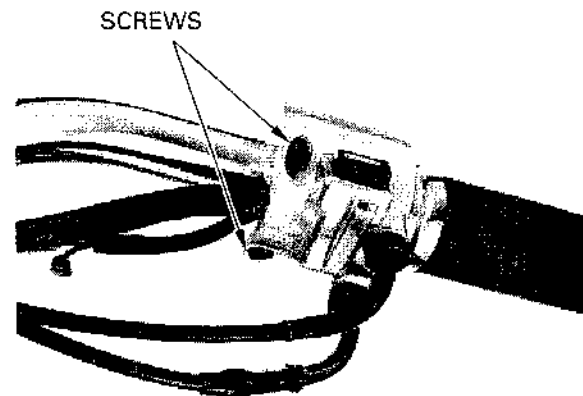

Install the master cylinder and holder with the "UP" mark facing up. Align the end of the master cylinder with the punch mark on the handlebar and tighten the upper bolt first, then tighten the lower bolt to the specified torque.

**TORQUE:** 12 N·m (1.2 kgf·m , 9 lbf·ft)

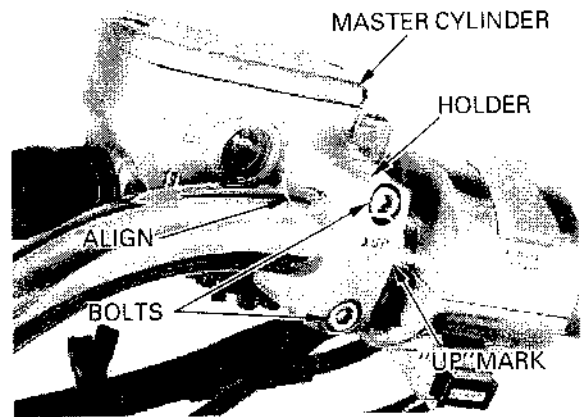

Connect the front brake light switch connectors to the switch.

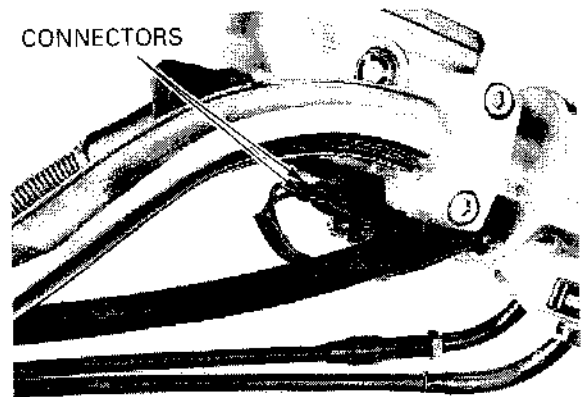

Install the adapter and left handlebar grip onto the handlebar (refer to page 13-4).

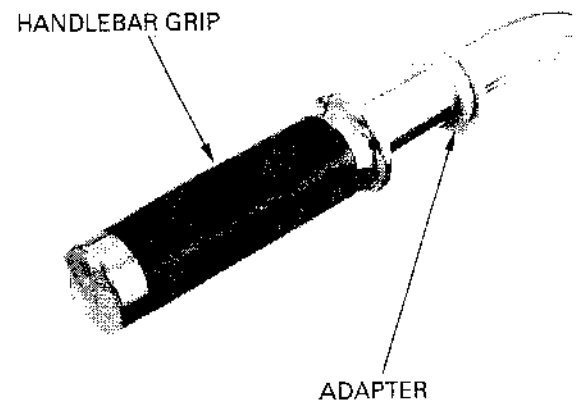

Install the left handlebar switch housing onto the handlebar, aligning the locating pin with the hole in the handlebar.

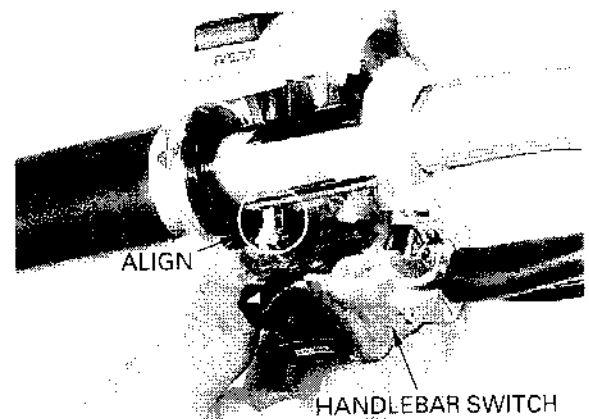

## FRONT WHEEL/SUSPENSION/STEERING

Install the attaching screws and tighten the forward screw then tighten the rear screw.

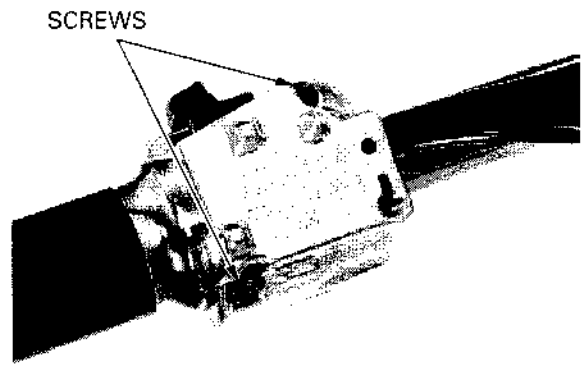

Install the clutch switch into the clutch lever bracket.

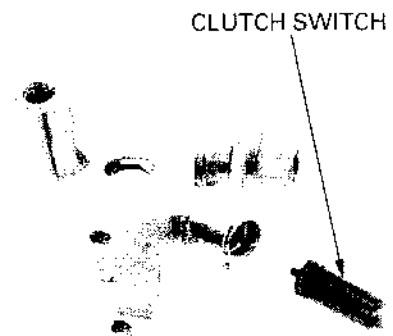

Install the clutch lever bracket and holder with the "UP" mark facing up.

Align the end of the clutch lever bracket with the punch mark on the handlebar and tighten the upper bolt then tighten the lower bolt to the specified torque.

**TORQUE:** 12 N·m (1.2 kgf·m, 9 lbf·ft)

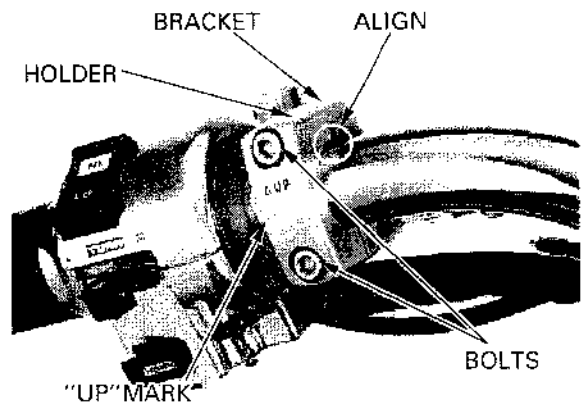

Connect the clutch switch connectors to the clutch switch.

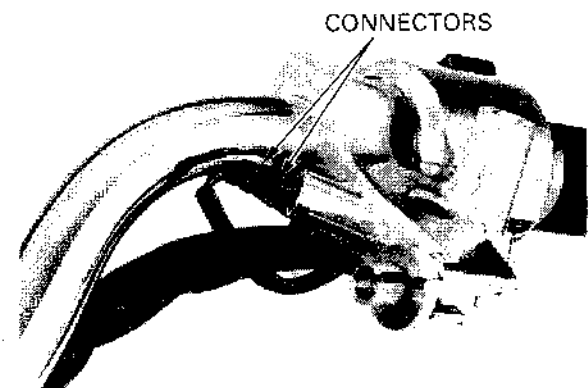

Install the clutch lever to the clutch lever bracket.  
Install and tighten the bolt and nut securely.

Connect the clutch cable to the lever.

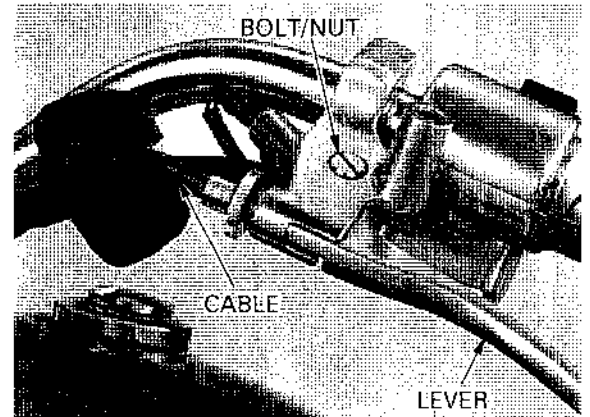

Install the right and left rearview mirrors.

**NOTE:**

Route the cables, wires and harness properly  
(page 1-22).

Adjust the followings:

- Throttle operation free play (page 3-5).
- Clutch lever free play (page 3-28).

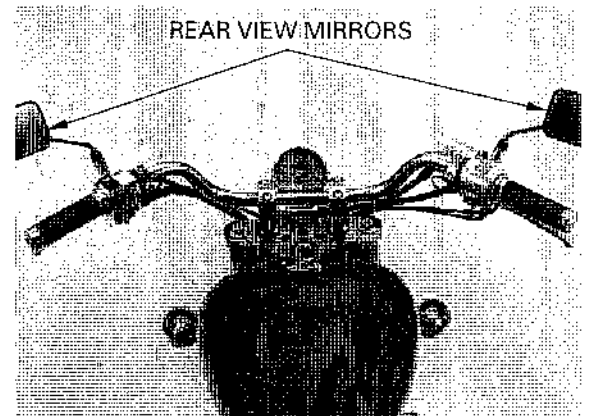

## FRONT WHEEL

**▲WARNING**

*A contaminated brake disc or pad reduces stopping power. Discard contaminated pads and clean a contaminated disc with a high quality brake degreasing agent.*

### REMOVAL

Raise and support the motorcycle using a hoist or jack under the engine.

**CAUTION:**

*Do not jack up the motorcycle using oil filter.*

Remove the screw and disconnect the speedometer cable from the speedometer gear.

Remove the axle pinch bolt caps.

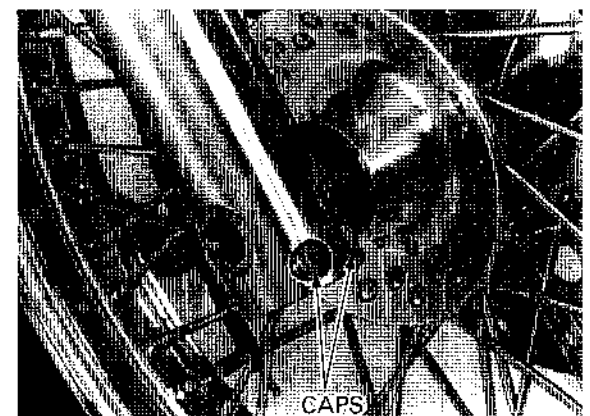
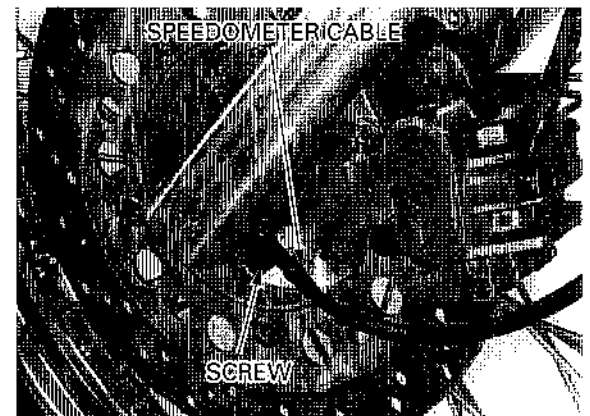

## FRONT WHEEL/SUSPENSION/STEERING

Loosen the axle pinch bolts.  
Remove the axle and front wheel.

### NOTE:

Do not operate the front brake lever after removing the front wheel. To do so will cause difficulty in fitting the brake disc between the brake pads.

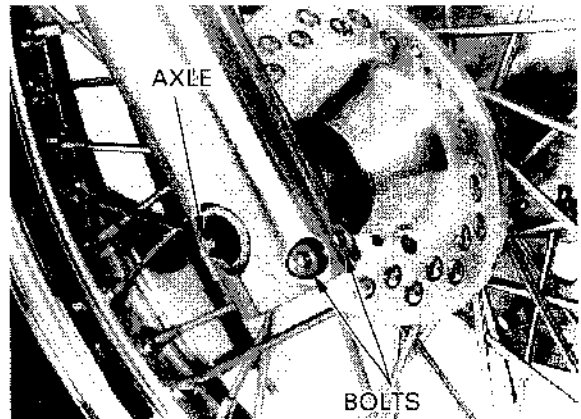

Remove the side collar.

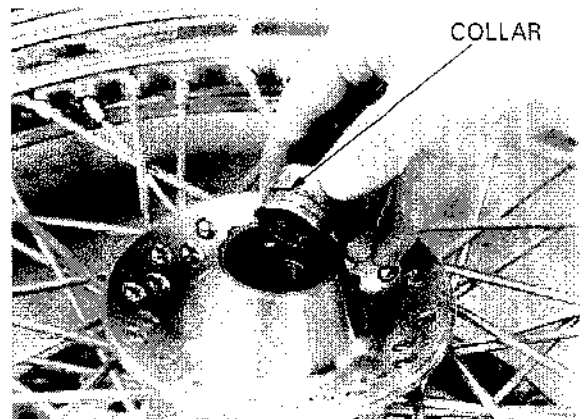

Remove the speedometer gear box.



## INSPECTION

### AXLE

Set the front axle in V-blocks and measure the runout.  
Turn the front axle and measure the runout using a dial indicator.  
Actual runout is 1/2 the total indicator reading.

**SERVICE LIMIT:** 0.20 mm (0.008 in)

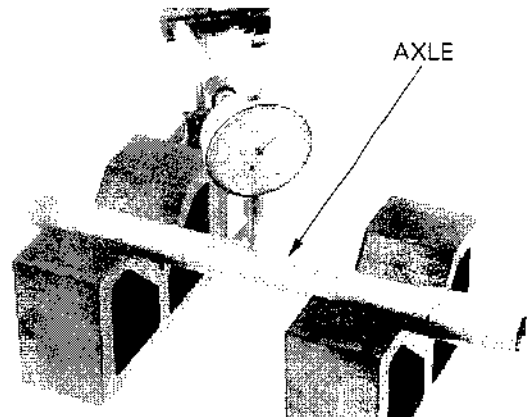



## WHEEL BEARING

Turn the inner race of each bearing with your finger. The bearings should turn smoothly and quietly. Also check that the bearing outer race fits tightly in the hub.

*Replace the wheel bearings in pairs.*

Remove and discard the bearings if the races do not turn smoothly and quietly, if they fit loosely in the hub.

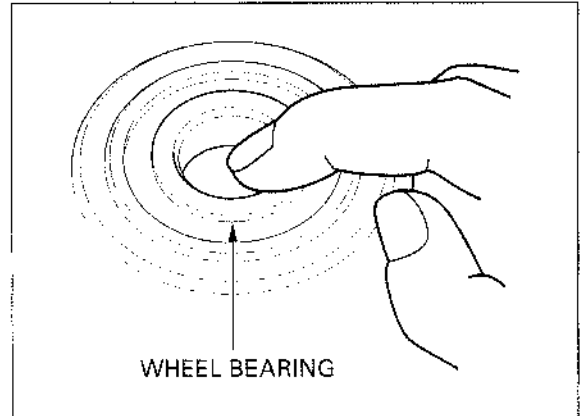

## WHEEL RIM

Check the rim runout by placing the wheel in a truing stand. Spin the wheel slowly and read the runout using a dial indicator. Actual runout is 1/2 the total indicator reading.

### SERVICE LIMITS:

**Radial:** 2.0 mm (0.08 in)

**Axial:** 2.0 mm (0.08 in)

Check the spokes for looseness or damage.

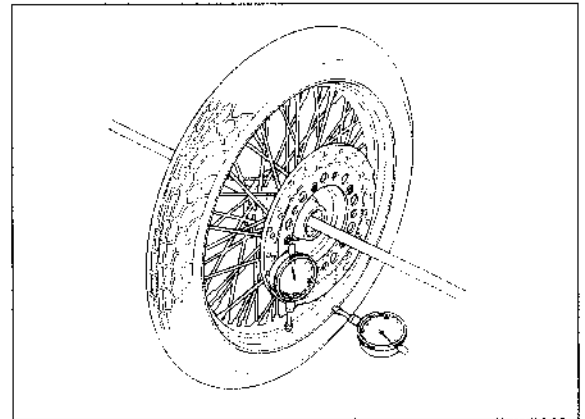

## DISASSEMBLY

Remove the brake disc mounting bolts and brake disc.

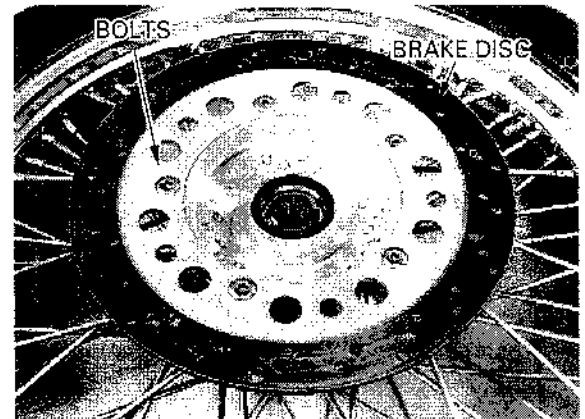

Remove the right and left dust seals from the each side of the front wheel.

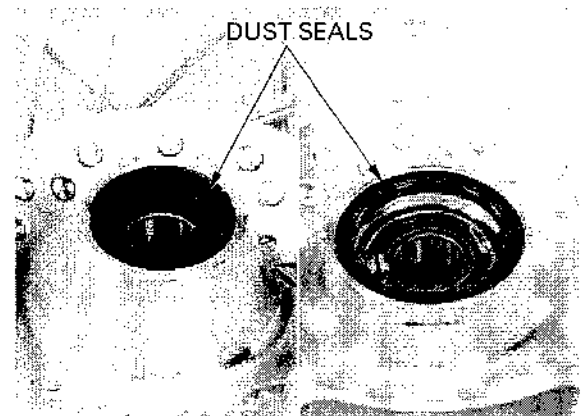

## FRONT WHEEL/SUSPENSION/STEERING

Remove the speedometer gear retainer.

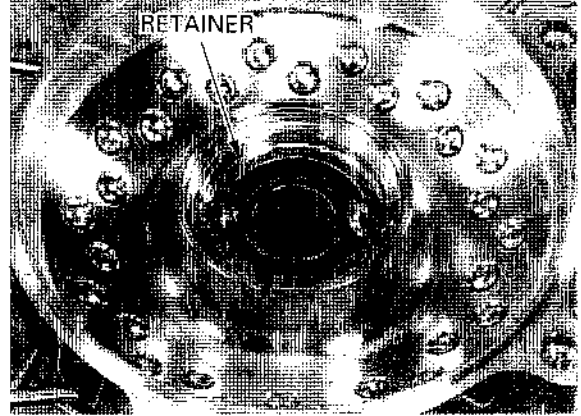

Replace the wheel bearings in pairs. Do not reuse old bearings.

Install the bearing remover head into the bearing. From opposite side install the bearing remover shaft and drive the bearing out of the wheel hub. Remove the distance collar and drive out the other bearing.

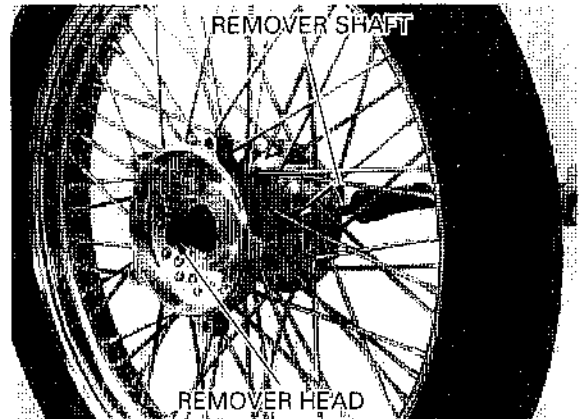

### TOOLS:

Bearing remover shaft 07746-0050100  
 Bearing remover head 07746-0050600

## ASSEMBLY

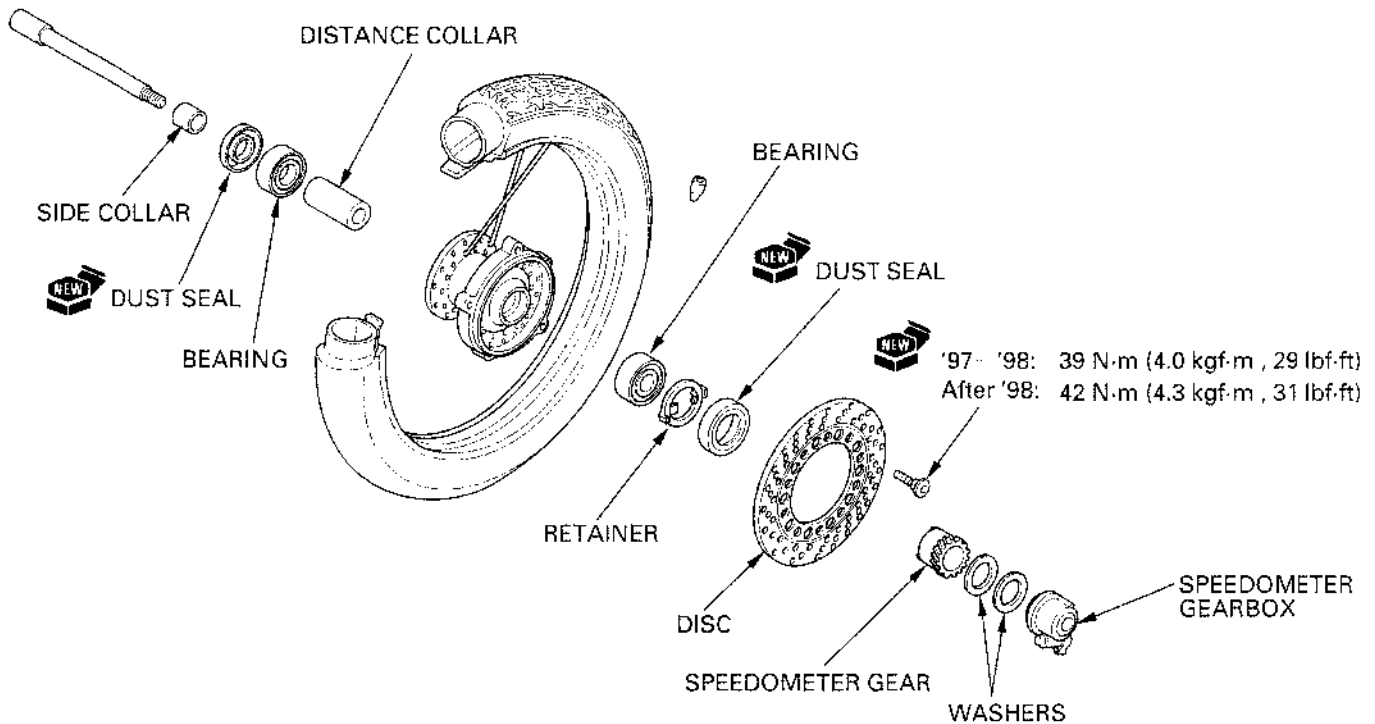

Drive in a new right bearing squarely with the marking side facing up until it is fully seated.  
 Install the distance collar.  
 Drive in a new left bearing squarely with the marking side facing up until it is fully seated.

**TOOLS:**

<b>Driver</b>	07749--0010000
<b>Attachment, 42 × 47 mm</b>	07746--0010300
<b>Pilot, 20 mm</b>	07746--0040500

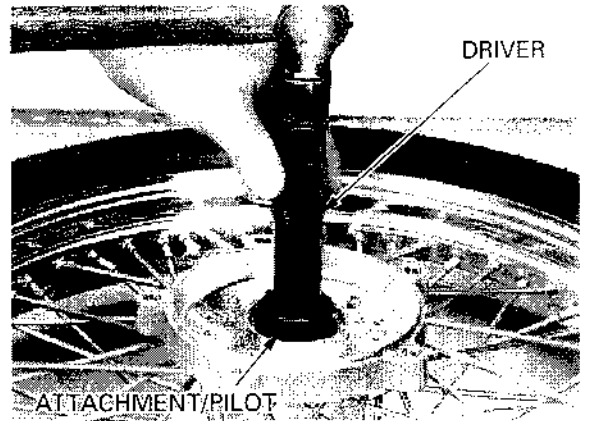

Assemble the wheel as follows if the wheel has been disassembled.  
 Clean the spoke nipple threads.  
 Adjust the hub position so that the distance from the hub left end surface to the side of rim is as shown.

**STANDARD:** 32.3 ± 0.8 mm (1.27 ± 0.03 in)

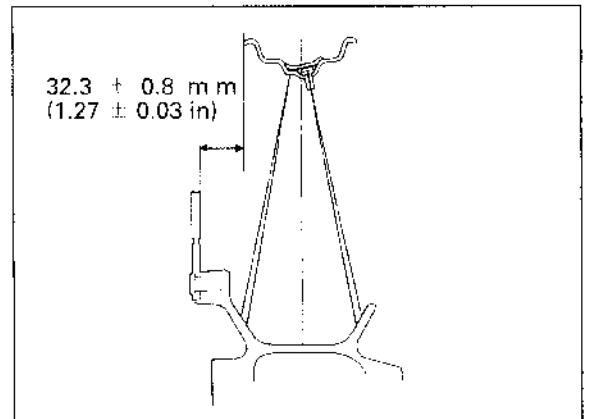

Torque the spokes in 2 or 3 progressive steps.

**TOOL:**

<b>Spoke wrench</b>	07JMA--MR60100 or equivalent commercially available in U.S.A.
---------------------	---

**TORQUE:** 4 N·m (0.4 kgf·m , 2.9 lbf·ft)

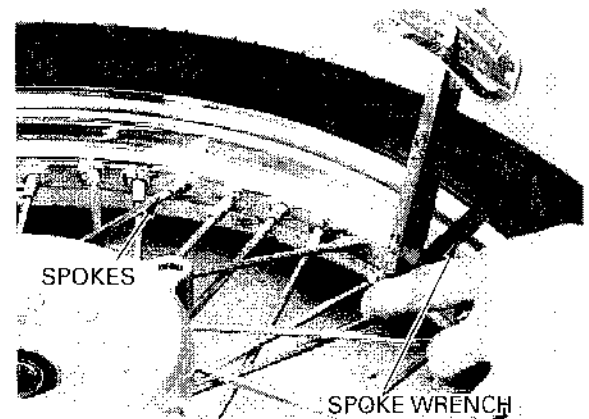

Install the brake disc with the "MIN.TH.4MM" marked side facing out.

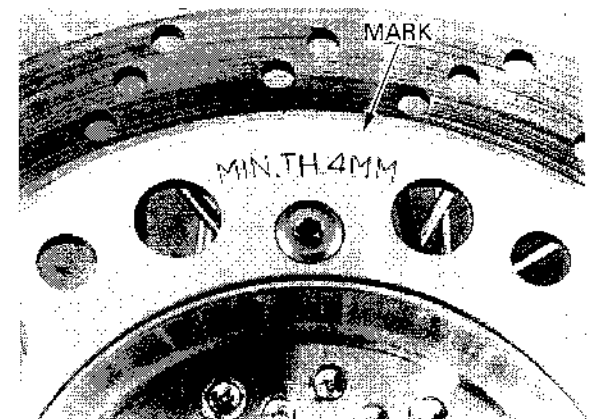

## FRONT WHEEL/SUSPENSION/STEERING

Install and tighten the new brake disc bolts to the specified torque.

### NOTE:

Tighten the bolts in a crisscross pattern in 2 or 3 steps.

**TORQUE:** '97 – '98: 39 N·m (4.0 kgf·m , 29 lbf·ft)  
After '98: 42 N·m (4.3 kgf·m , 31 lbf·ft)

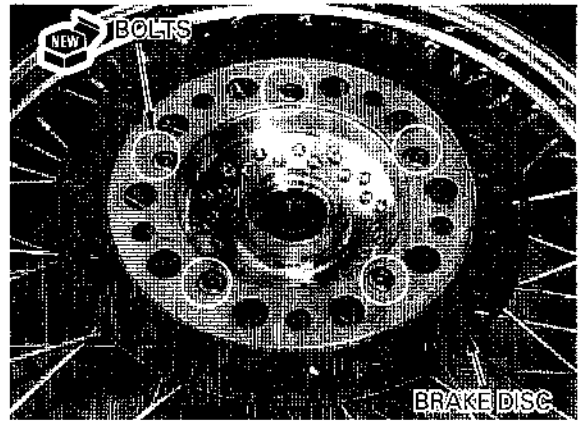

### WHEEL BALANCE

#### ▲WARNING

*Wheel balance directly affects the stability, handling and overall safety of the motorcycle. Carefully check balance before reinstalling the wheel.*

### NOTE:

- The wheel balance must be checked when the tire is remounted.
- For optimum balance, the tire balance mark (a paint dot on the side wall) must be located next to the valve stem. Remount the tire if necessary.

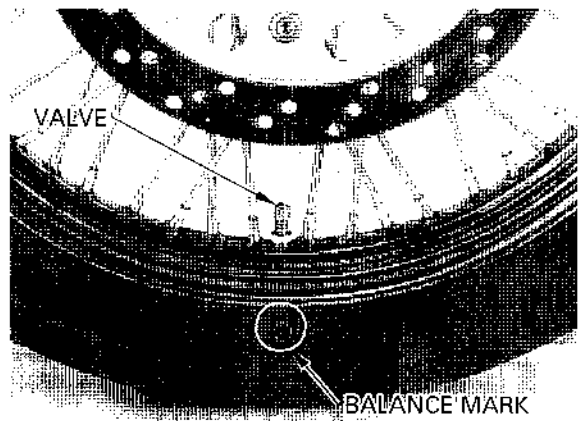

Mount the wheel, tire and brake disc assembly on an inspection stand.

Spin the wheel, allow it to stop, and mark the lowest (heaviest) part of the wheel with chalk.

Do this two or three times to verify the heaviest area.

If the wheel is balanced, it will not stop consistently in the same position.

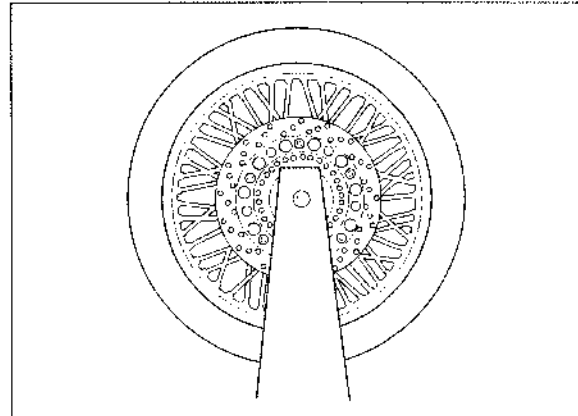

To balance the wheel, install balance weights on the lightest side of rim, the side opposite the chalk marks. Add just enough weight so the wheel will no longer stop in the same position when it is spun. Do not add more than 70 g (2.5 oz) to the front wheel.

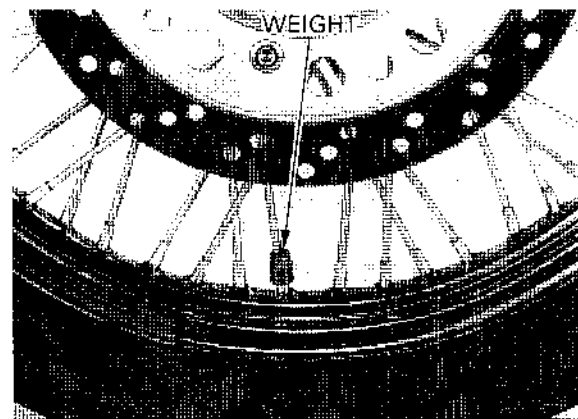

Install the speedometer gear retainer to the wheel hub aligning the tangs on the retainer with the slots on the hub.

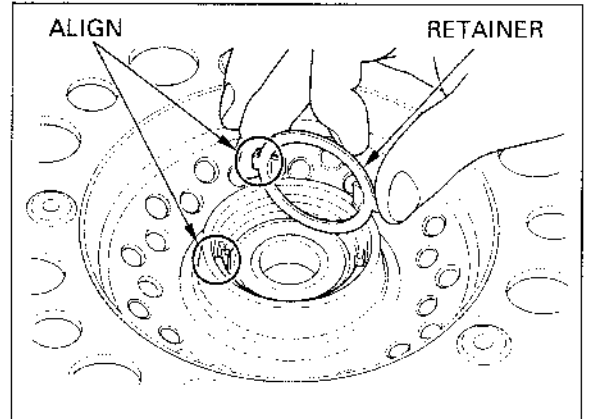

### **⚠WARNING**

*Do not get grease on the brake disc or stopping power will be reduced.*

Apply grease to the new right dust seal lip.  
Install the right dust seal to the right wheel hub.

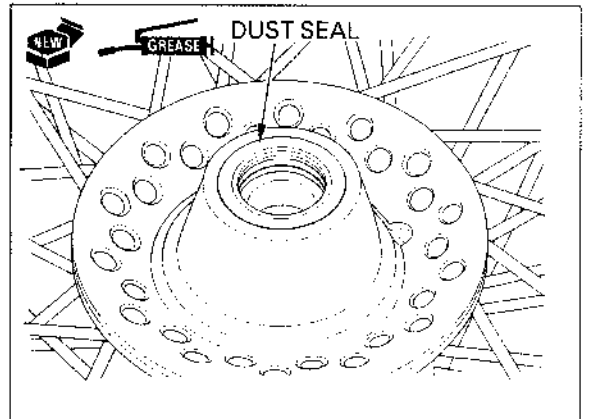

Apply grease to the new left dust seal lip.  
Install the left dust seal lip to the left wheel hub.

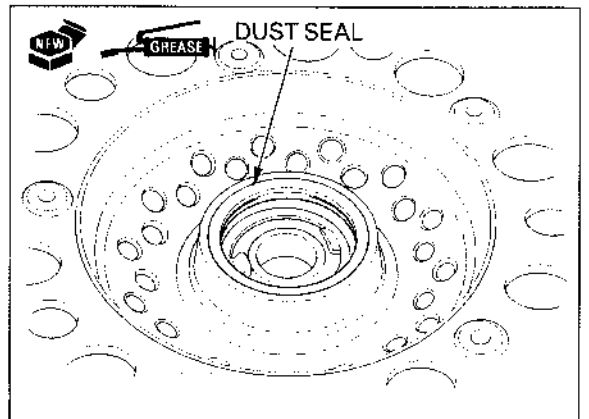

## INSTALLATION

Apply grease to the inside of speedometer gear box and gear.  
Install the speedometer gear and washers into the gear box.

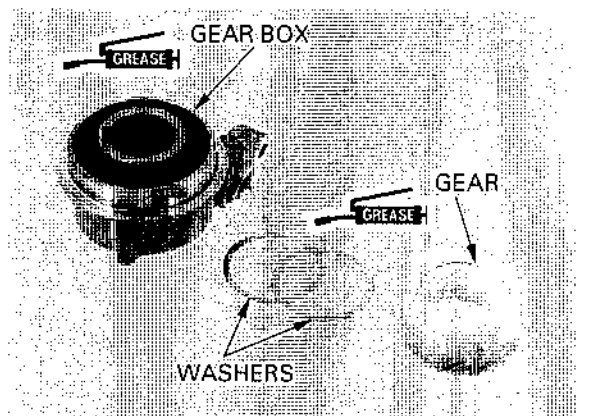

## FRONT WHEEL/SUSPENSION/STEERING

Install the speedometer gear box into the left wheel hub, aligning the tangs with the slots.

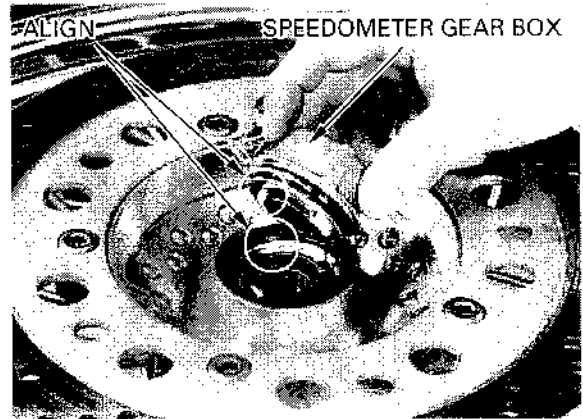

Install the side collar into the right wheel hub.

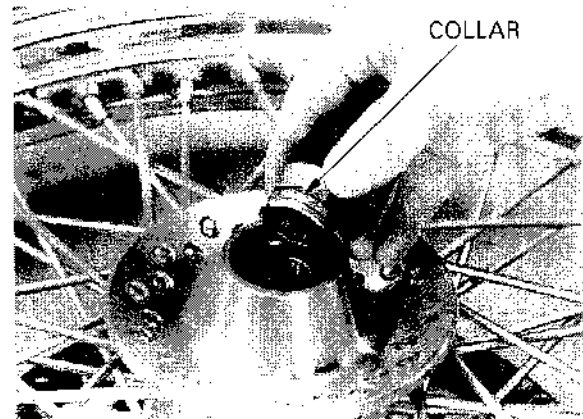

Install the front wheel between the fork legs so that the brake disc is positioned between the pads, being careful not to damage the pads.

Apply thin coat of grease to the front axle.  
Install the front axle.  
Position the lug on the speedometer gear box against the back of stopper on the fork leg.

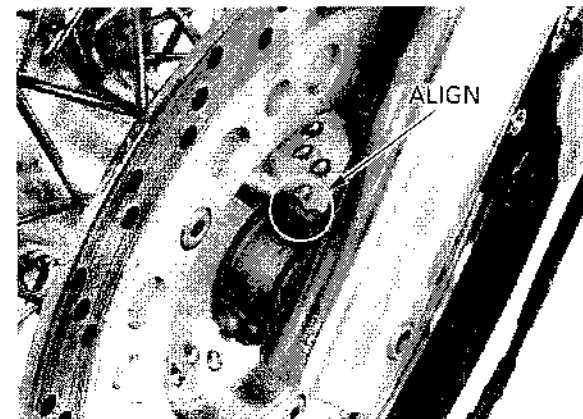

Tighten the front axle to the specified torque.

**TORQUE:** 74 N·m (7.5 kgf·m , 54 lbf·ft)

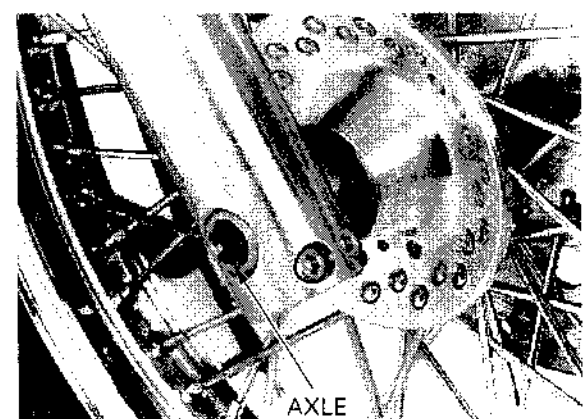

With the front brake applied, pump the front suspension up and down several times to seat the axle and check front brake operation.

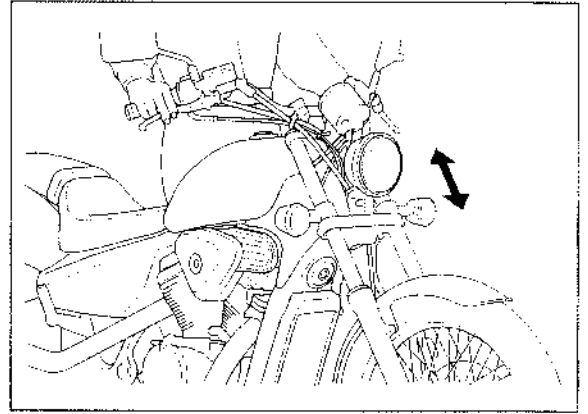

Tighten the axle pinch bolts to the specified torque.

**TORQUE:** 22 N·m (2.2 kgf·m , 16 lbf·ft)

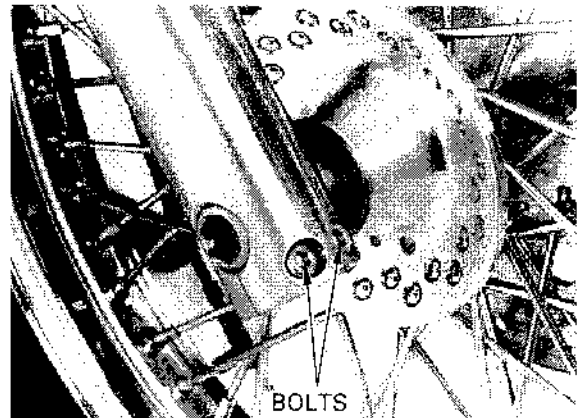

Install the axle pinch bolt caps.

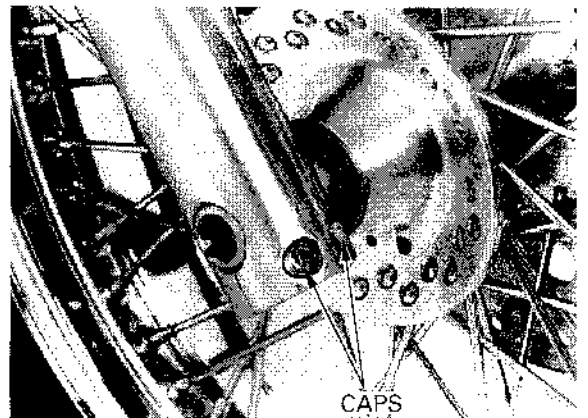

Install the speedometer cable and tighten the screw securely.

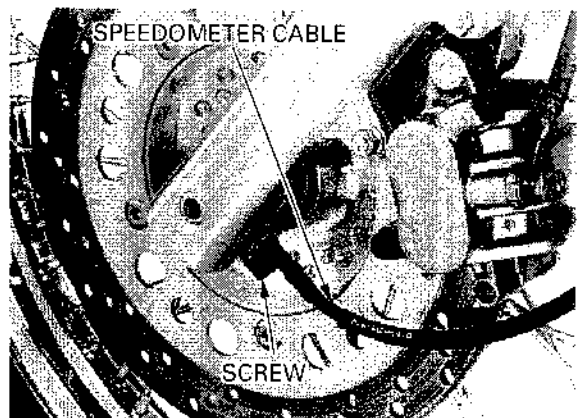

## FORK

### REMOVAL

Remove the front wheel (page 13-13).

Pull the speedometer cable out of the cable holder on the front fender.

Unhook the brake hose from the hook on the front fender.

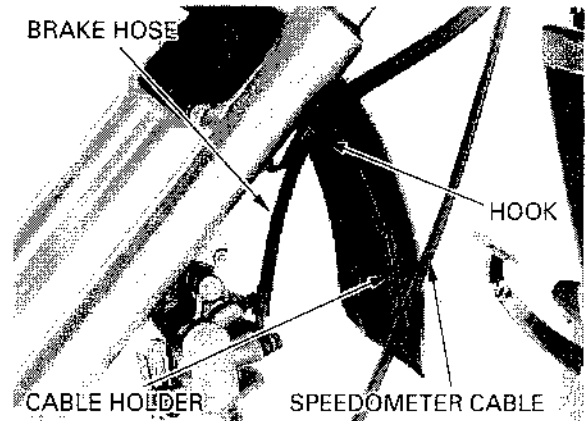

Remove the front fender mounting bolts and front fender.

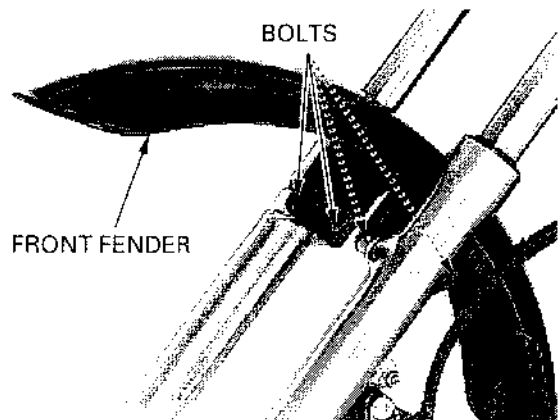

### NOTE:

Do not operate the front brake lever after removing the front wheel. To do so will cause difficulty in fitting the brake disc between the brake pads.

Remove the brake caliper mounting bolts and brake caliper.

### CAUTION:

- *Do not suspend the brake caliper from the brake hose.*
- *Do not twist the brake hose.*

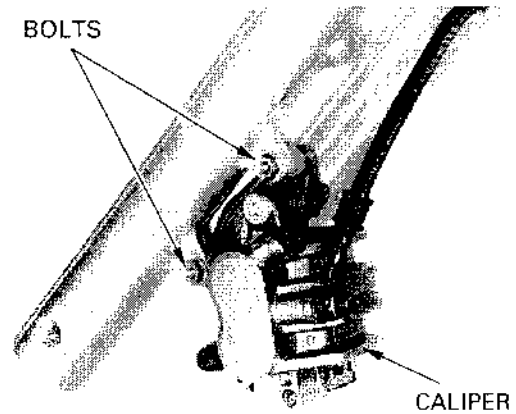

Remove the bolt, collar and turn signal light assembly from the fork tube.

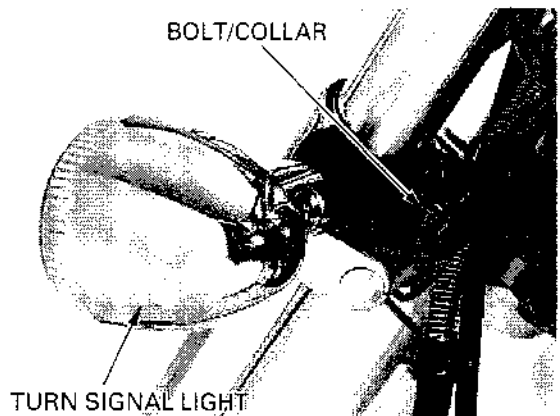



Remove the fork top bridge pinch bolt caps.

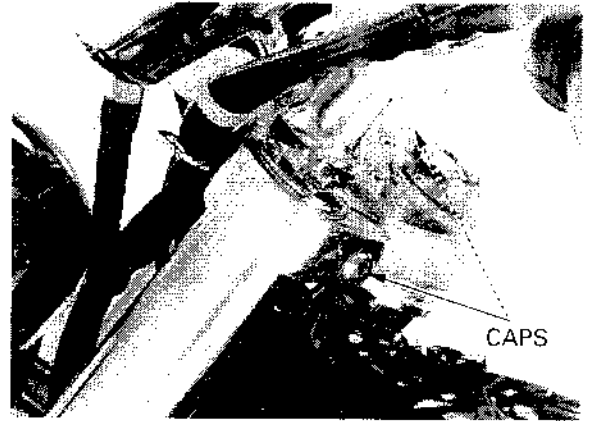

Loosen the fork top bridge pinch bolts. When the fork is ready to be disassembled, loosen the fork cap, but do not remove it.

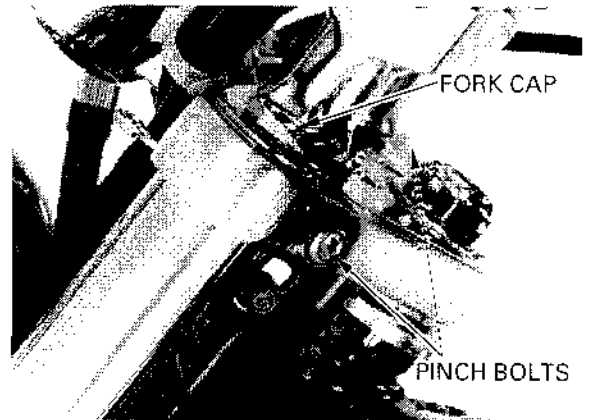

Remove the fork bottom bridge pinch bolt caps.

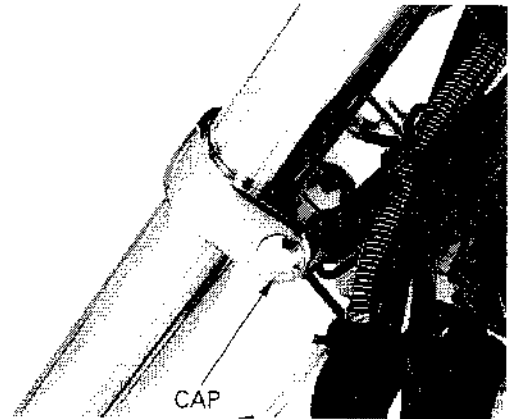

Loosen the fork bottom bridge pinch bolts while holding the fork. Remove the fork from the top bridge and steering stem.

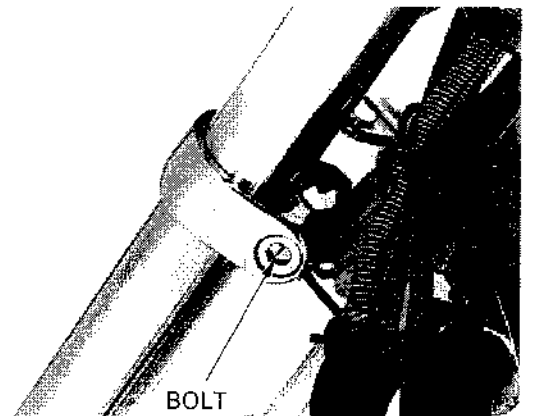

### DISASSEMBLY

**▲WARNING**

*The fork cap is under spring pressure. Use care when removing it and wear eye and face protection.*

---

Remove the fork cap and O-ring from the fork tube.

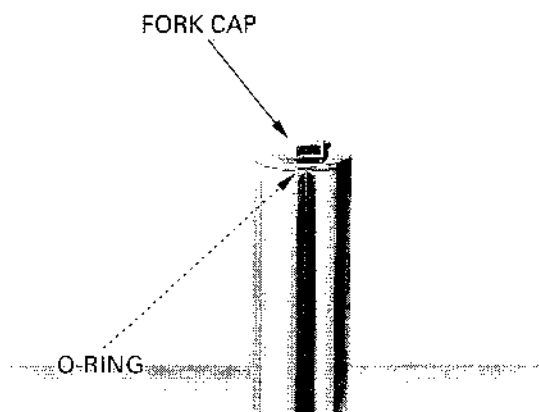

Remove the spring spacer from the fork tube.

SPACER

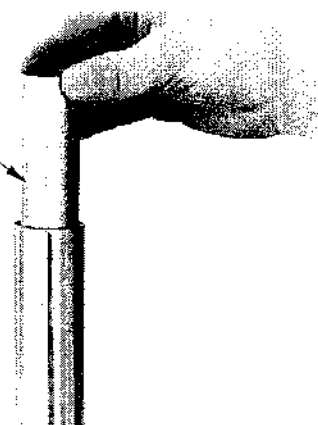

Remove the washer.

WASHER

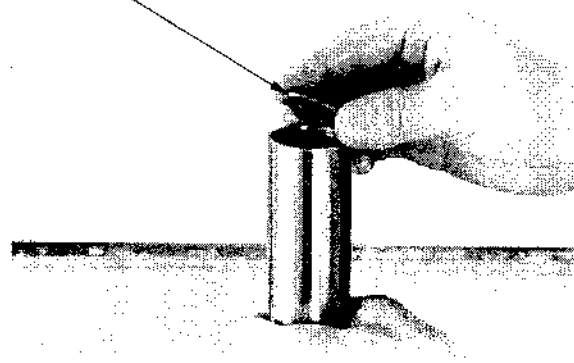

Remove the fork spring.

SPRING

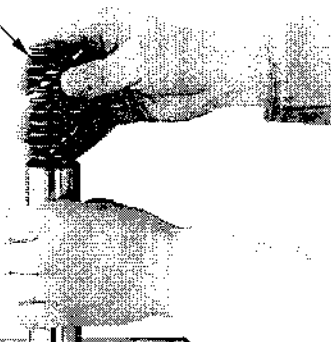

Pour the fork oil from the fork leg by pumping the fork 8–10 times.

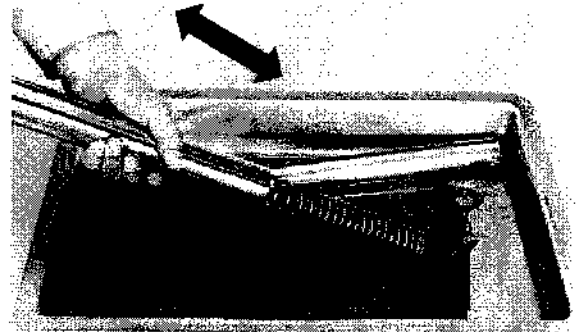

**CAUTION:**

*Do not over tighten the fork slider.*

Hold the axle holder in a vise with a piece of wood or soft jaws to avoid damage.

Install the special tool into the fork tube and hold the piston, then remove the socket bolt and sealing washer.

**TOOLS:**

- Bottom holder pipe** 07930–KA50000  
Not available in U.S.A.
- **Holder attachment** 07930–KA50100  
Equivalent commercially available in U.S.A.
- **Bottom holder handle** 07930–KA40200  
Equivalent commercially available in U.S.A.

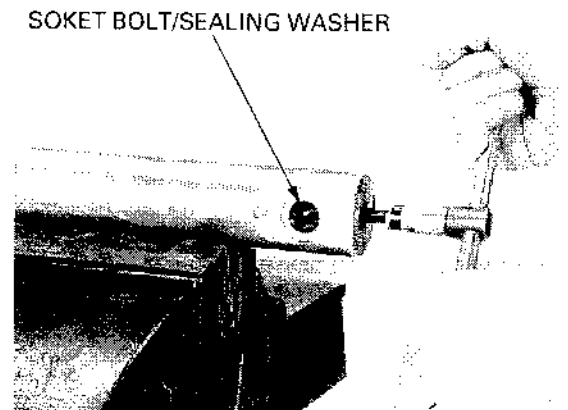
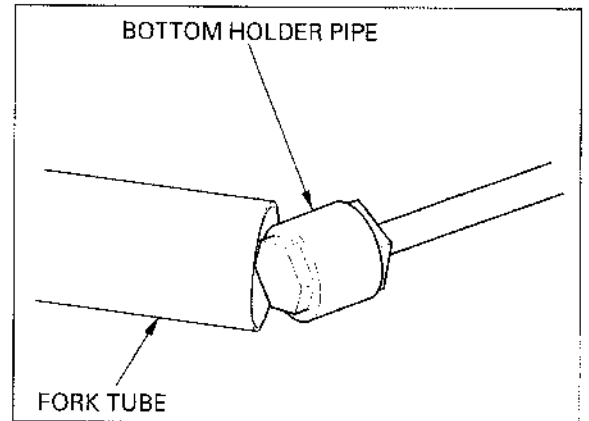

Remove the fork piston and rebound spring.

**NOTE:**

Do not remove the fork piston ring, unless it is necessary to replace with a new one.

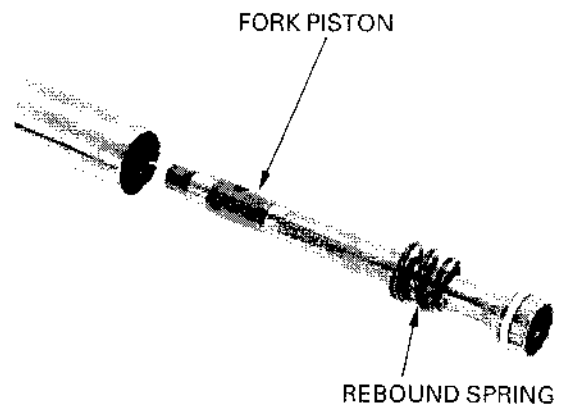

## FRONT WHEEL/SUSPENSION/STEERING

Remove the dust seal from the fork slider.

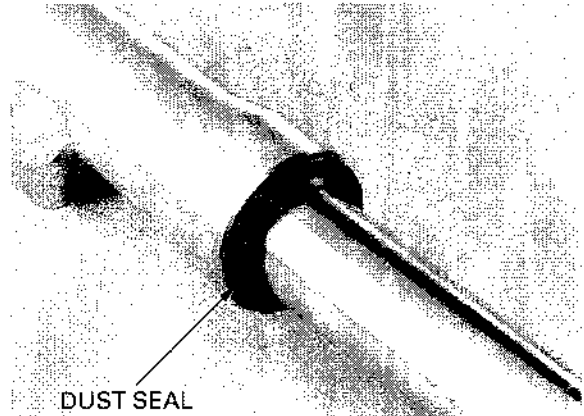

Remove the stopper ring from the groove of the fork slider.

**CAUTION:**

*Do not scratch the fork tube sliding surface.*

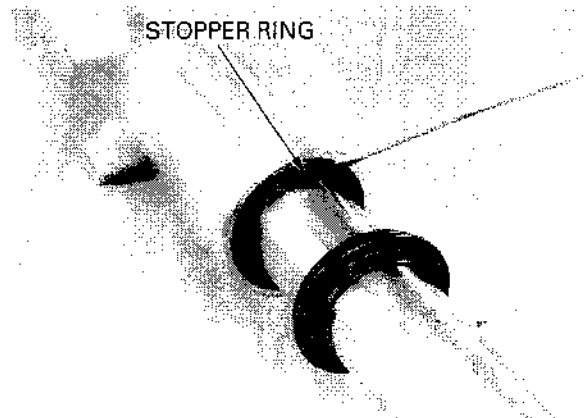

**NOTE:**

Check that the fork tube moves smoothly in the fork slider. If does not, check the fork tube for bending or damage, and bushings for wear or damage.

Using quick successive motions, pull the fork tube out of the fork slider.

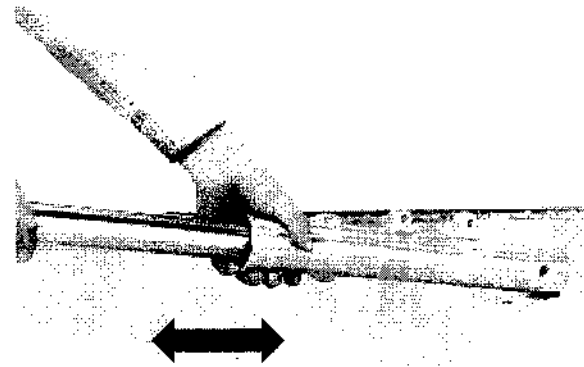

Remove the oil lock piece from the fork slider.

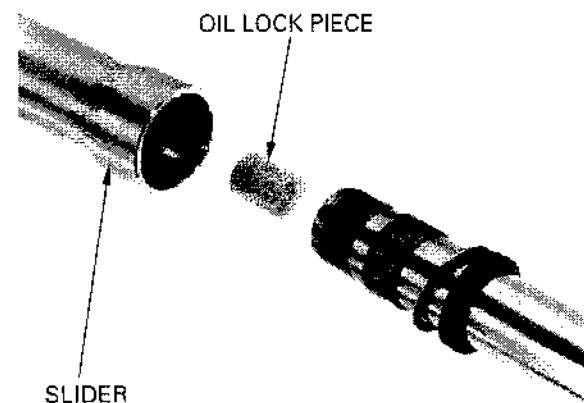

Remove the oil seal, back-up ring and slider bushing from the fork tube.

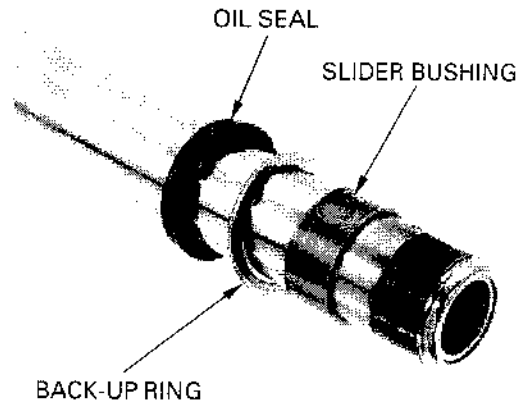

### NOTE:

Do not remove the fork tube bushing unless it is necessary to replace it with a new one.

Carefully remove the fork tube bushing by prying the slot with a screwdriver until the bushing can be pulled off by hand.

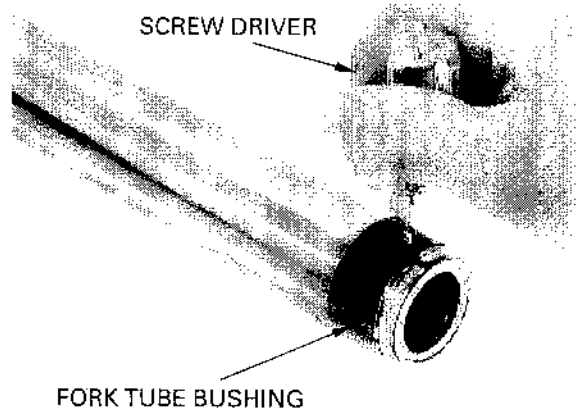

## INSPECTION

### FORK SPRING

Measure the fork spring free length by placing the spring on a flat surface.

**SERVICE LIMIT:** 327.2 mm (12.88 in)

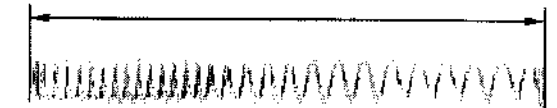

### FORK TUBE/SLIDER/FORK PISTON

Check the fork tube, slider and fork piston for score marks, and excessive or abnormal wear.

Replace the component if necessary.

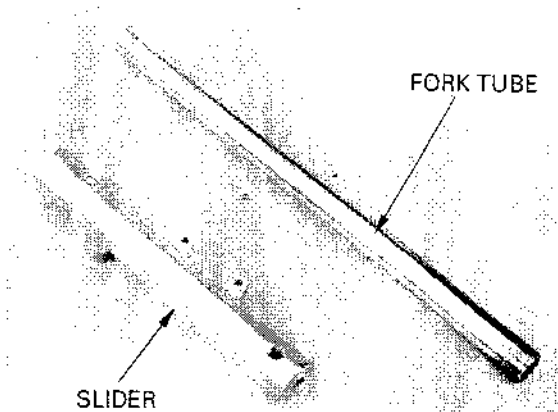

## FRONT WHEEL/SUSPENSION/STEERING

Check the fork piston ring for wear or damage.  
Check the rebound spring for fatigue or damage.

Replace the component if necessary.

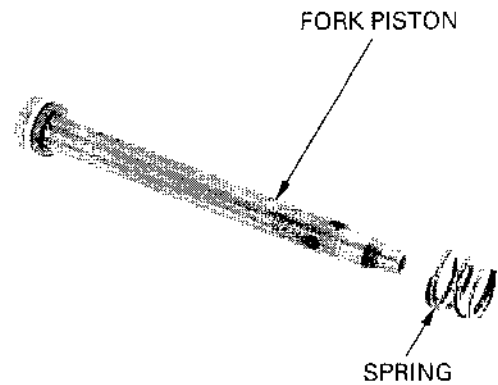

Set the fork tube in V-blocks and measure the fork tube runout rotating it with a dial indicator. Actual runout is 1/2 the total indicator reading.

**SERVICE LIMIT:** 0.20 mm (0.008 in)

Replace if the service limit is exceeded, or there are scratches or nicks that will allow fork oil to leak past the seals.

### NOTE:

Do not reuse the fork tube if it cannot be perfectly straightened with minimal effort.

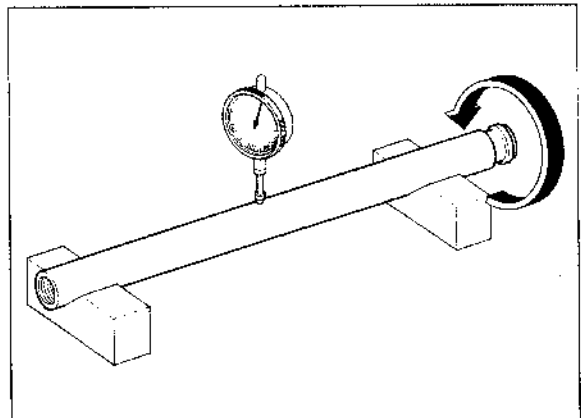

### FORK TUBE BUSHING

Visually inspect the slider and fork tube bushings. Replace the bushings if there is excessive scoring or scratching, or if the teflon is worn so that the copper surface appears on more 3/4 of the entire surface.

Check the back-up ring; replace it if there is any distortion at the point shown.

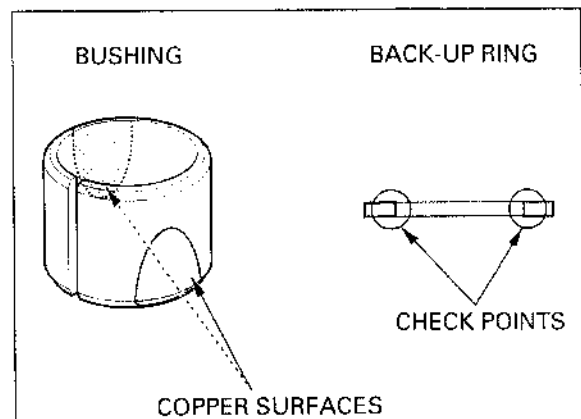

**ASSEMBLY**

Before assembly, wash all parts with a high flash point or non-flammable solvent and wipe them off completely.

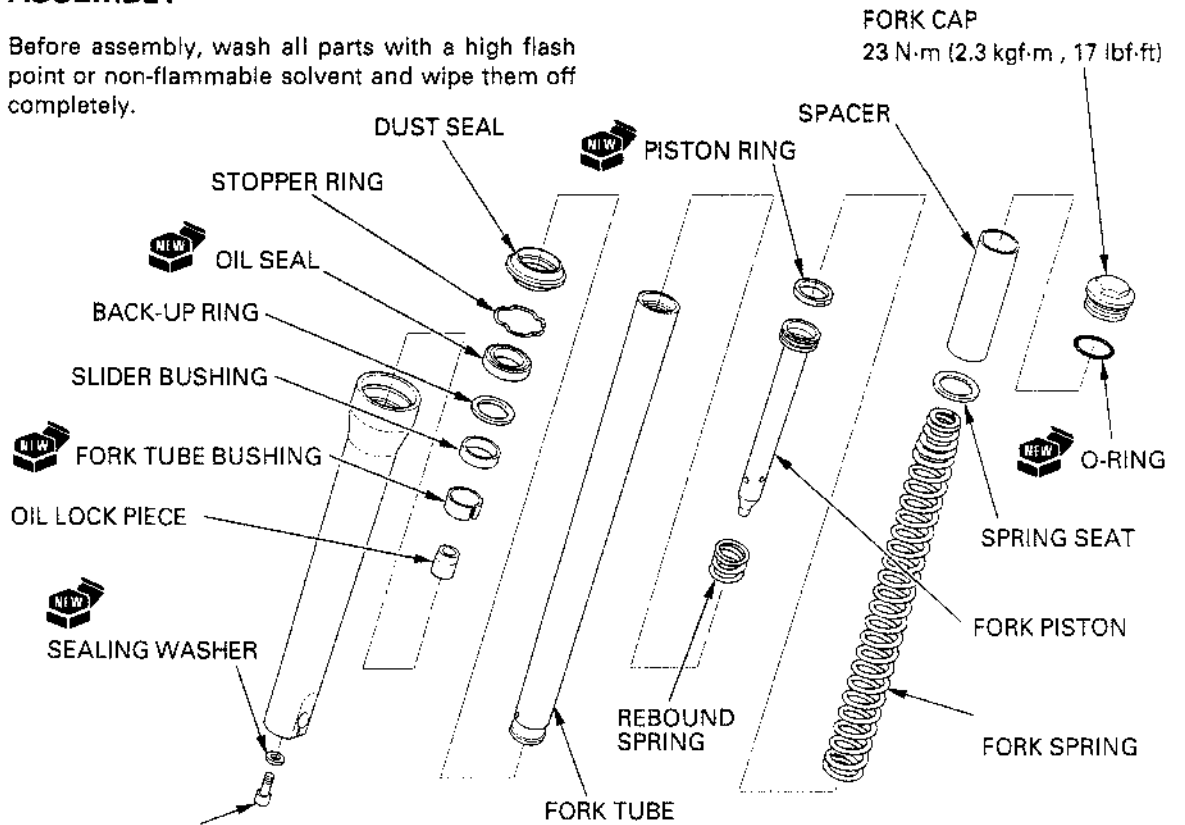

FORK SOCKET BOLT  
29 N·m (3.0 kgf·m, 22 lbf·ft)

Install a new fork tube bushing if the tube bushing has been removed.

**CAUTION:**

- *Be careful not to damage the fork tube bushing coating.*
- *Do not open the fork tube bushing more than necessary.*

**NOTE:**

Remove the burrs from the bushing mating surface, being careful not to peel off the coating.

Install the slider bushing and back-up ring to the fork tube.  
Apply fork oil to the new oil seal lip.  
Install the new oil seal to the fork tube with the marking side facing up.

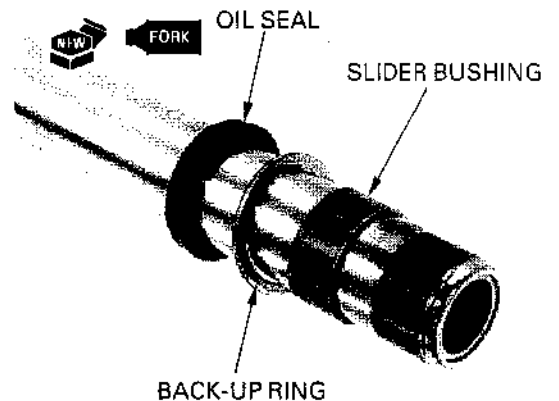
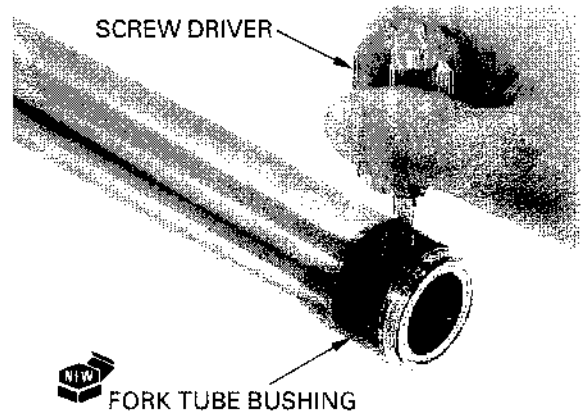

## FRONT WHEEL/SUSPENSION/STEERING

Install the oil lock piece onto the fork piston end.  
Coat the fork tube bushing with the fork oil and  
install the fork into the fork slider.

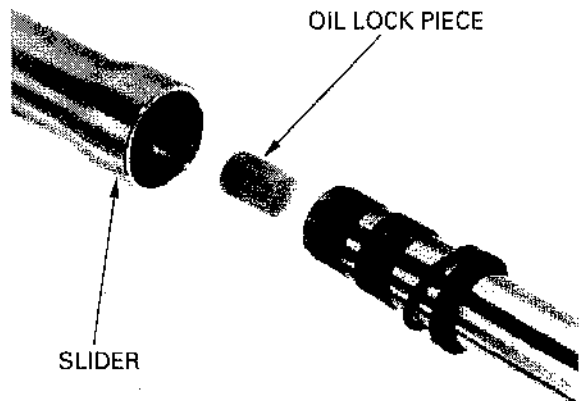

Install the rebound spring to the fork piston.

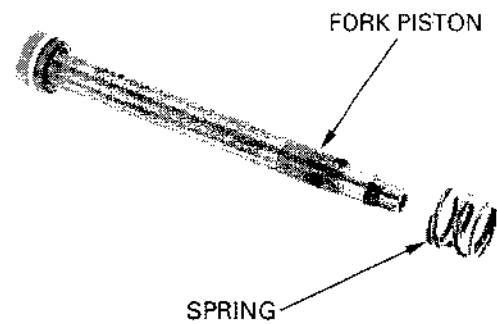

Install the fork piston into the fork tube.

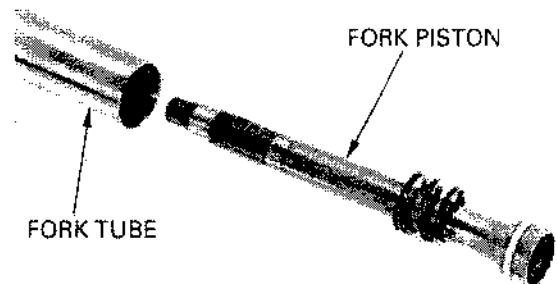

Install the special tools into the fork tube to hold the piston.

### TOOLS:

**Bottom holder pipe**

— Holder attachment

— Bottom holder handle

07930 — KA50000  
Not available in U.S.A.  
07930 — KA50100  
Equivalent commercial-  
ly available in U.S.A.  
07930 — KA40200  
Equivalent commercial-  
ly available in U.S.A.

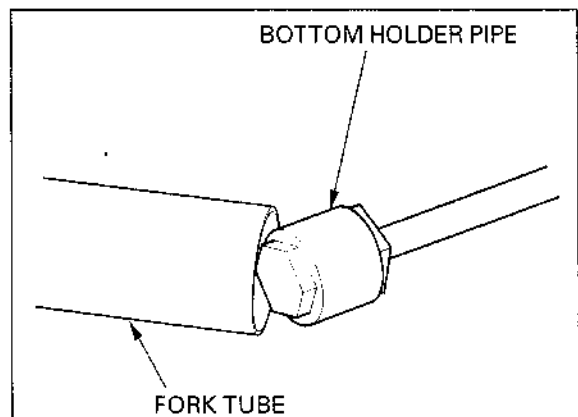



**CAUTION:**

***Do not overtighten the fork slider.***

Hold the axle holder of the fork slider in a vise with a piece of wood or soft jaws to avoid damage. Replace the sealing washer with a new one. Clean and apply a locking agent to the fork socket bolt threads and install the fork socket bolt with the new sealing washer into the fork piston.

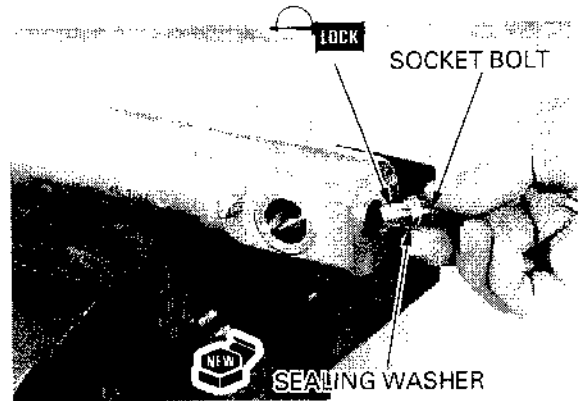

Tighten the fork socket bolt to the specified torque.

**TORQUE:** 29 N·m (3.0 kgf·m , 22 lbf·ft)

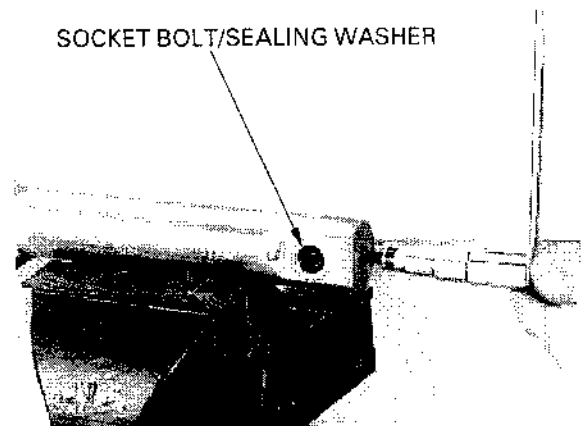

Drive in the new oil seal into the fork tube until the stop ring groove is visible, using the special tool.

**TOOLS**

**Fork seal driver, 39 mm**    07947-4630100

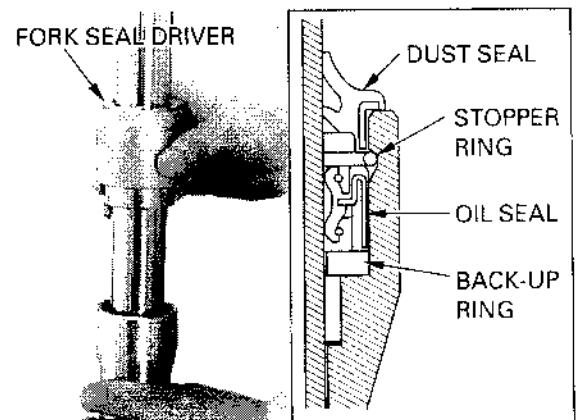

Install the stopper ring into the groove in the fork slider.

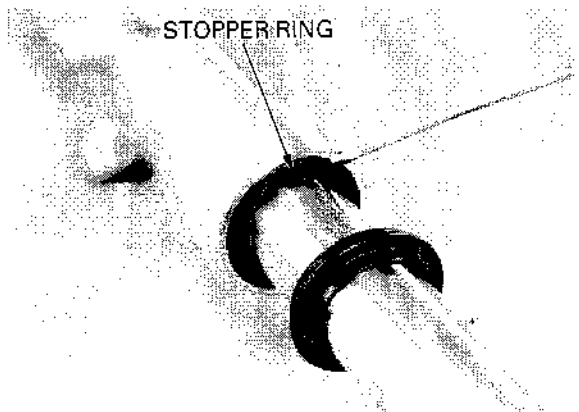

## FRONT WHEEL/SUSPENSION/STEERING

Apply fork oil to the lip of a new dust seal and install the dust seal.

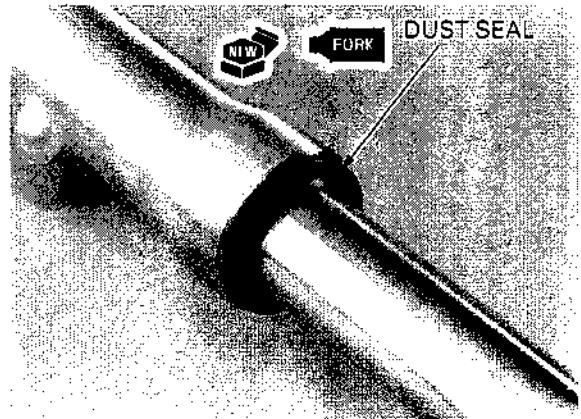

Pour half the required amount of the recommended fork oil in the fork tube.

**RECOMMENDED FORK OIL:**  
Honda Suspension Fluid SS-8 or equivalent  
**OIL CAPACITY:** 449 cm<sup>3</sup> (16.9 US oz, 15.8 Imp oz)

Slowly pump the fork tube several times to remove trapped air.  
Pour additional oil up to the specified capacity and repeat the above step.  
Compress the fork leg fully.  
Measure the oil level from the top of the fork tube.

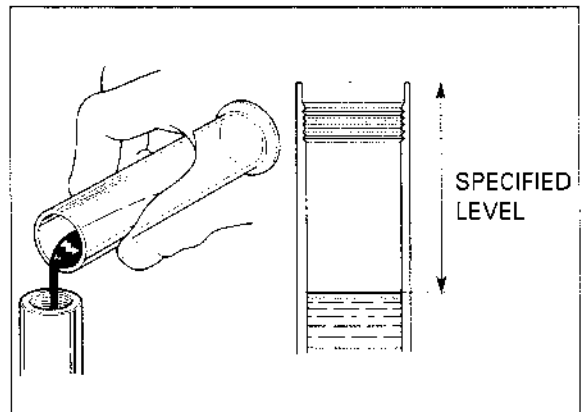

**OIL LEVEL:** 111 mm (4.4 in)

Install the fork spring with the tightly wound end facing up.



FACING UP

Install the washer.

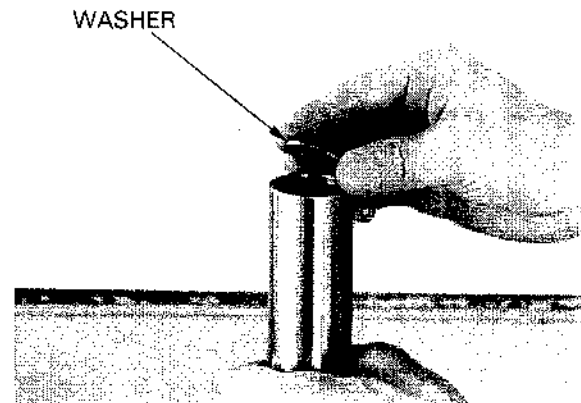

Install the spring spacer.

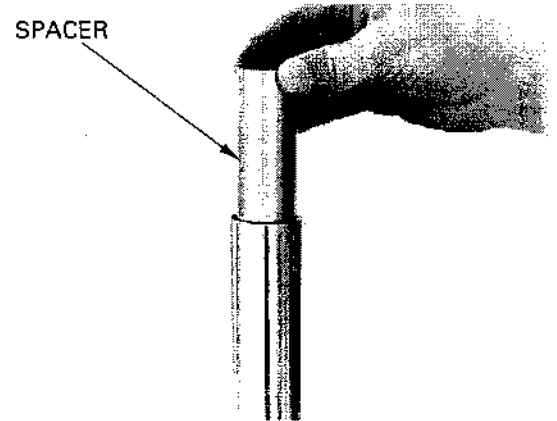

Apply fork oil to the new O-ring and install to the fork cap.  
Install the fork cap into the fork tube.

**NOTE:**

Tighten the fork cap after installing the fork tube into the fork bridge.

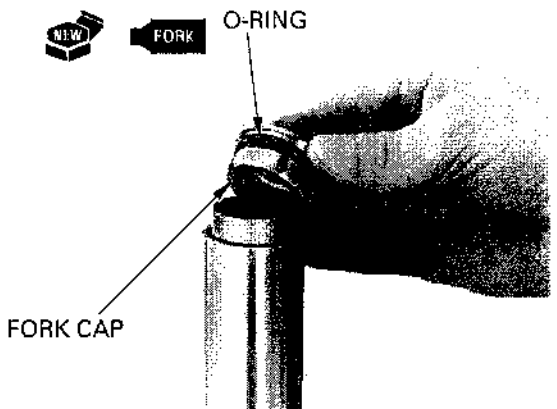

## INSTALLATION

Install the fork into the bottom and top bridge.

Align the top of fork tube with the upper surface of the top bridge.

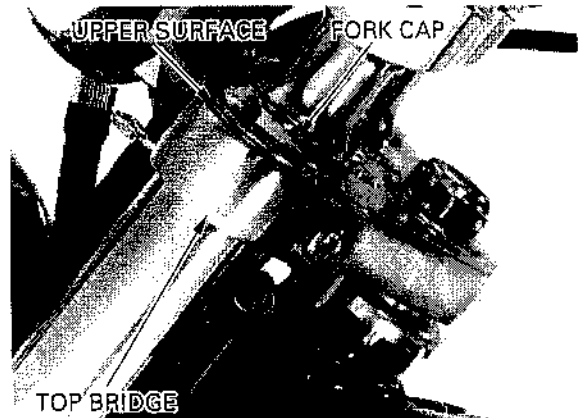

Tighten the bottom bridge pinch bolts to the specified torque.

**TORQUE:** 49 N·m (5.0 kgf·m , 36 lbf·ft)

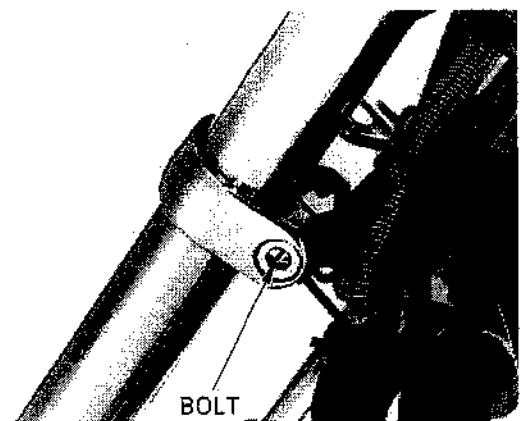

## FRONT WHEEL/SUSPENSION/STEERING

Install the bottom bridge pinch bolt caps.

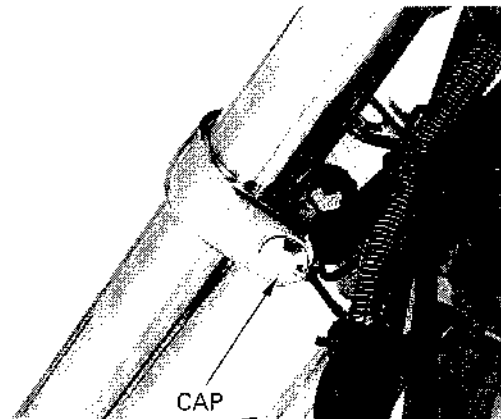

Tighten the fork cap to the specified torque.

**TORQUE:** 23 N·m (2.3 kgf·m , 17 lbf·ft)

Tighten the top bridge pinch bolts to the specified torque.

**TORQUE:** 11 N·m (1.1 kgf·m , 8 lbf·ft)

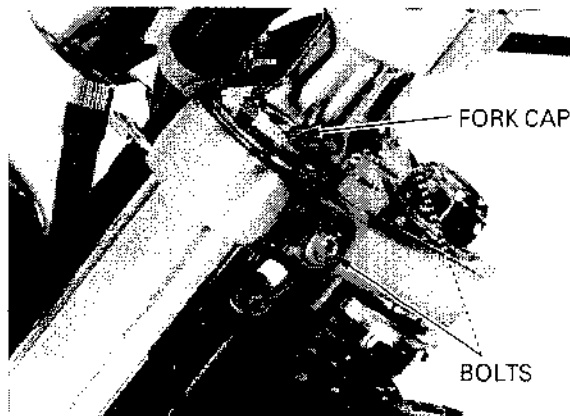

Install the top bridge pinch bolt caps.

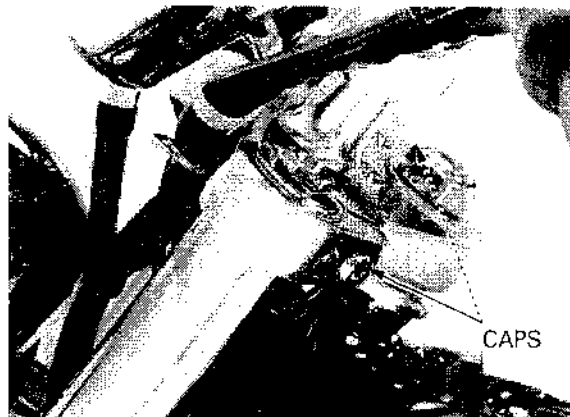

Install the turn signal light assembly and collar.  
Install and tighten the mounting bolt securely.

**NOTE:**

At installation, turn the signal stay with its tab into the bottom bridge cut-out.

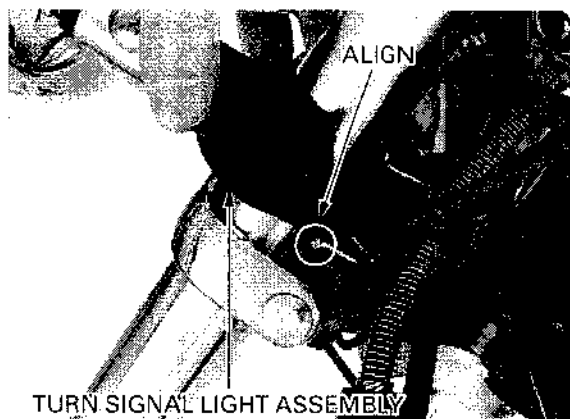

Install the brake caliper to the left front fork.  
Install and tighten the new front caliper mounting bolts to the specified torque.

**TORQUE:** 30 N·m (3.1 kgf·m , 22 lbf·ft)

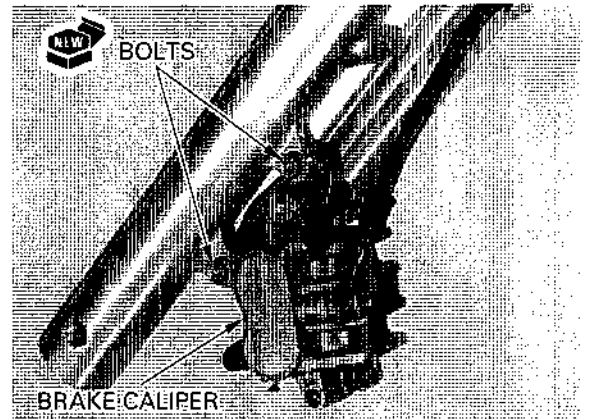

Install the front fender and tighten the mounting bolts securely.

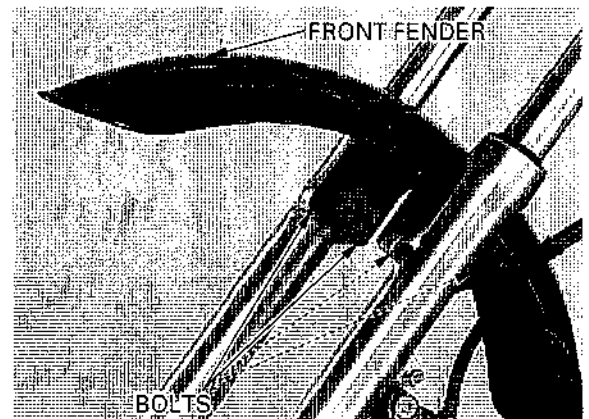

Hook the brake hose onto the hose hook.

Install the speedometer cable through the cable holder.

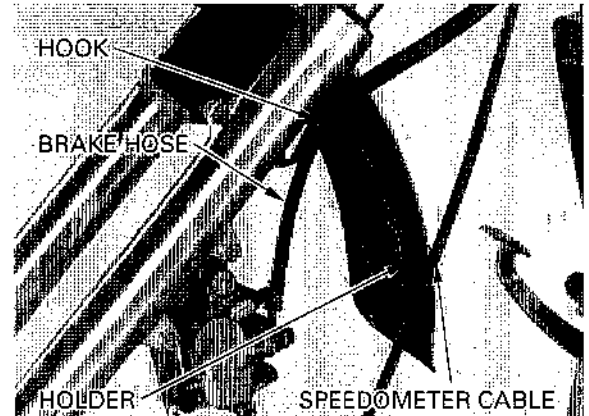

## STEERING STEM

### REMOVAL

Remove the handlebar (page 13-5).

Raise and support the motorcycle using a hoist.

Remove the steering cover (page 2-3) and disconnect the speedometer 6P (Black) connector.

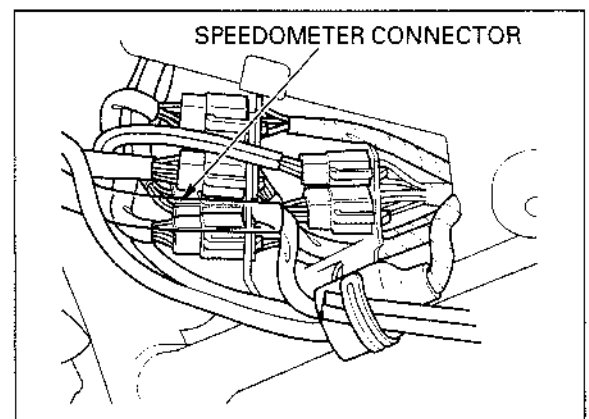

## FRONT WHEEL/SUSPENSION/STEERING

---

Disconnect the speedometer cable from the speedometer.  
Remove the bolt, nut and speedometer.

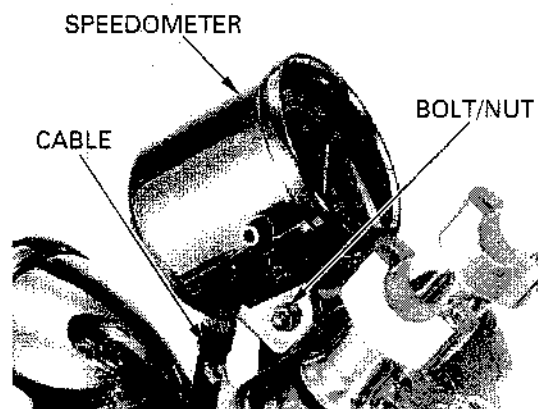

Remove the nuts and headlight/stay as assembly.

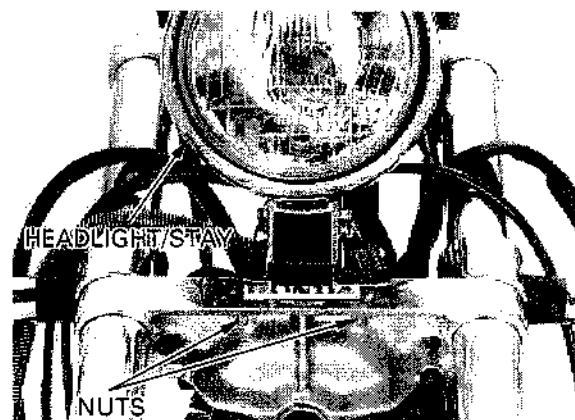

Remove the steering stem nut.

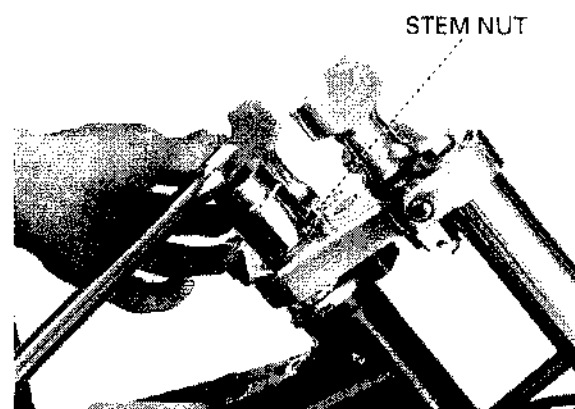

Remove the washer.

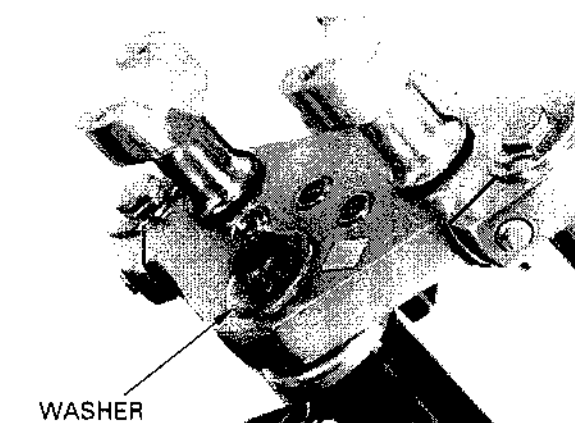

Remove the front forks (page 13-22).

Remove the top bridge.

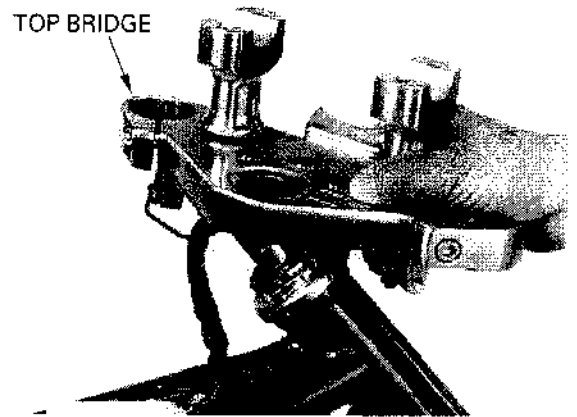

Remove the screws and indicator panel from the top bridge.

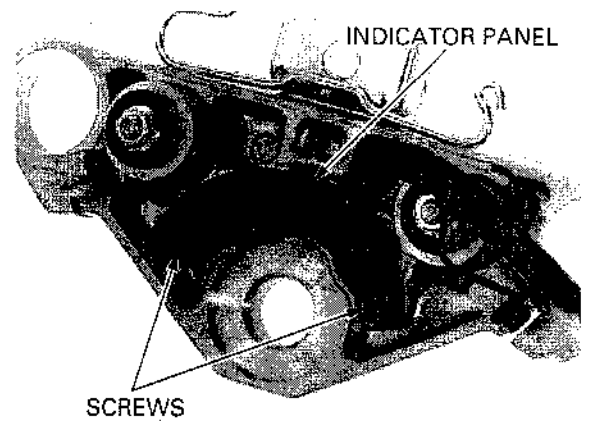

Remove the bolts and speedometer stay from the top bridge.

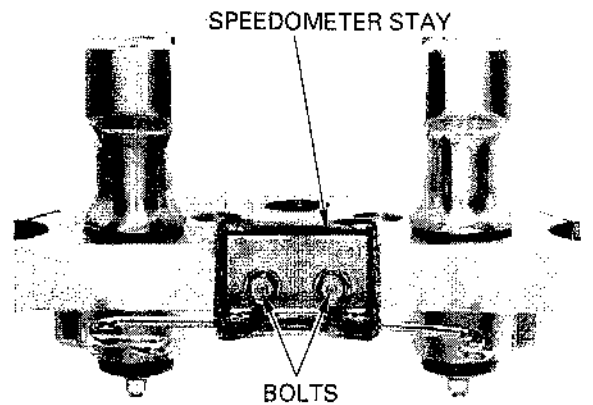

Straighten the lock washer tabs.



## FRONT WHEEL/SUSPENSION/STEERING

Remove the lock nut using following tool.

**TOOL:**

**Steering stem socket** 07916--3710100

Remove the lock washer.

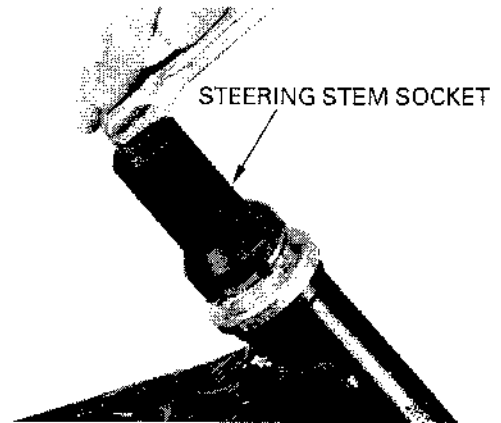

Remove the steering top thread using the following tool.

**TOOL:**

**Steering stem socket** 07916--3710100

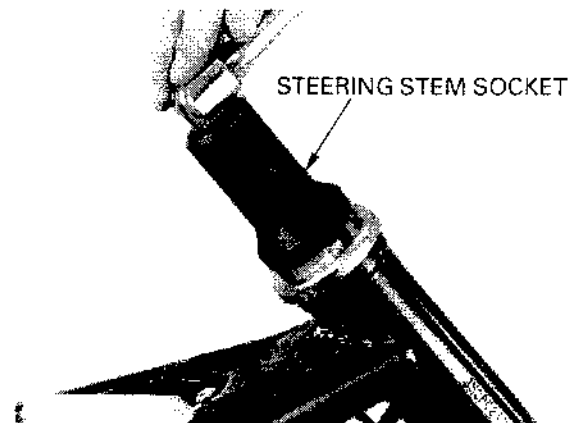

Hold the steering stem by hand and remove the steering top thread, dust seal, upper bearing inner race and upper bearing.

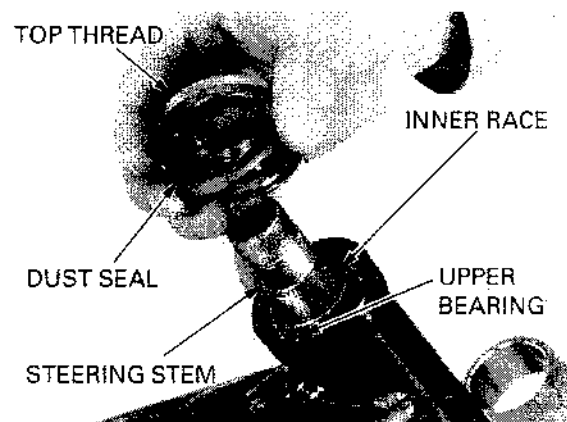

Remove the steering stem from the steering head.

Check the steering bearings, inner and outer races for wear or damage.

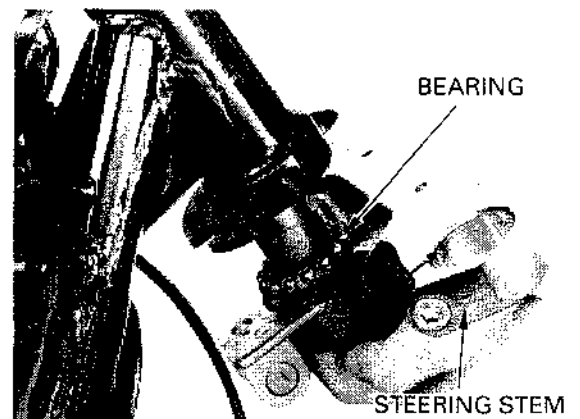



**STEERING BEARING REPLACEMENT**

*Always replace the bearings and races as a set.*

Remove the lower bearing outer race using the following tool and suitable shaft.

**TOOL:**  
**Bearing race remover** 07946 – 3710500

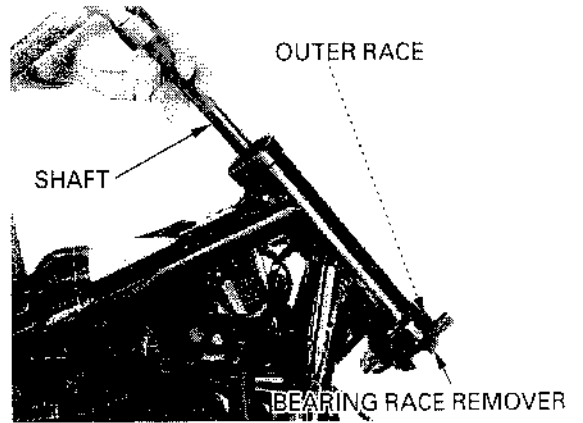

Remove the upper bearing outer race using the following tools.

**TOOLS:**  
**Ball race remover** 07953 – MJ10000  
 Not available in U.S.A.  
 – Attachment 07953 – MJ10100  
 Not available in U.S.A.  
 – Driver handle 07953 – MJ10200  
 Not available in U.S.A.

or  
**Race remover attachment** 07953 – MJ1000A or  
 07953 – MJ1000B  
**Driver** 07949 – 3710001 or  
**Attachment, 32 × 35 mm** 07746 – 0010100

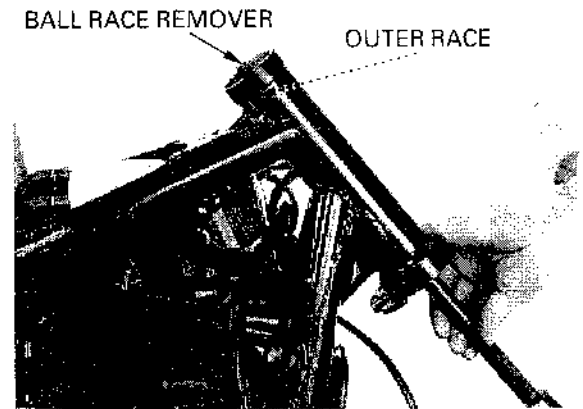

Install the stem nut onto the stem to prevent the threads from being damage when removing the lower bearing inner race from the stem.

Remove the lower bearing inner race with a chisel or equivalent tool, being careful not to damage the stem.

Remove the dust seal.

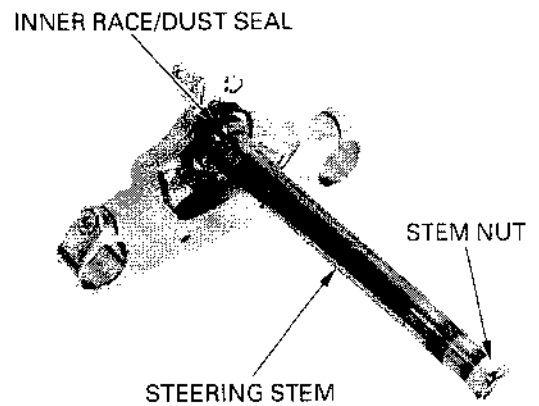

Apply grease to the new dust seal lip and install it to the steering stem.

Install the new lower bearing inner race using the following tool and hydraulic press.

**TOOL:**  
**Steering stem driver** 07946 – MB00000

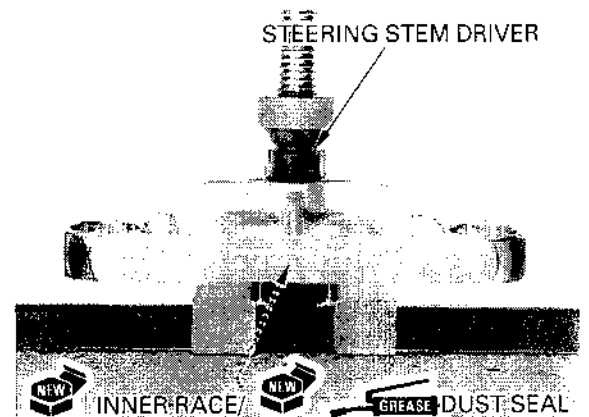

## FRONT WHEEL/SUSPENSION/STEERING

Drive the new upper bearing outer race into the head pipe using the following tools.

**TOOLS:**

**Driver** 07749-0010000  
**Attachment, 42 × 47 mm** 07746-0010300

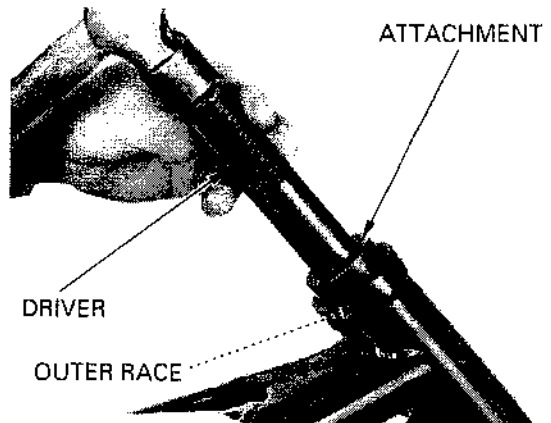

Drive the new lower bearing outer race into the head pipe using the following tools.

**TOOLS:**

**Driver** 07749-0010000  
**Attachment, 52 × 55 mm** 07746-0010400

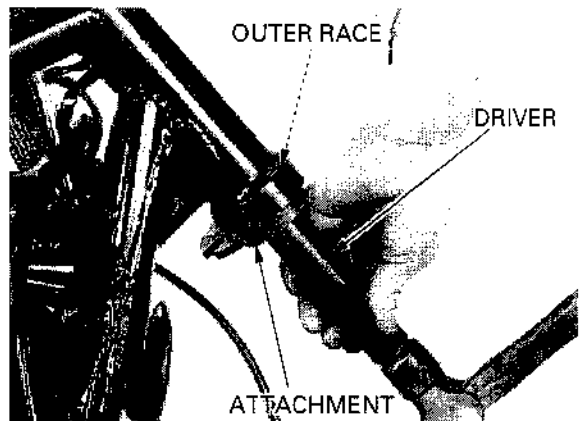

## INSTALLATION

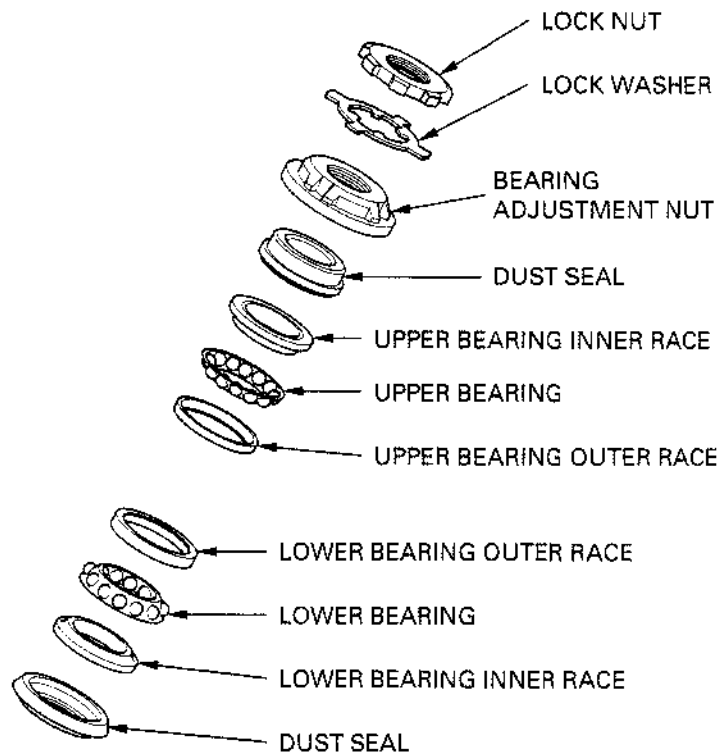
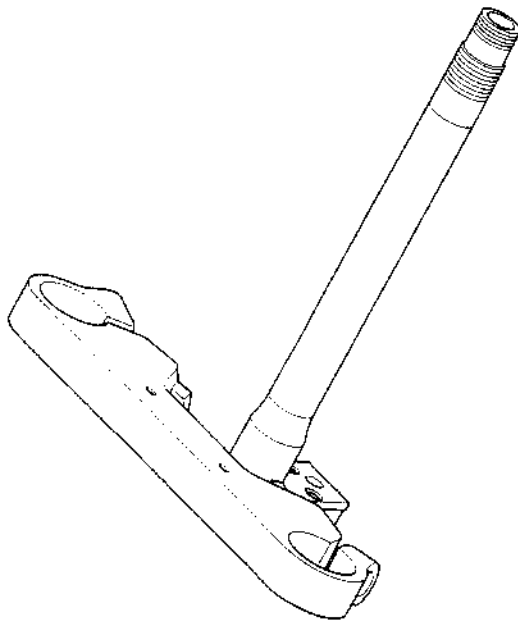

Apply grease to the new lower bearing.  
Install the new lower bearing onto the steering stem.  
Install the steering stem into the head pipe.

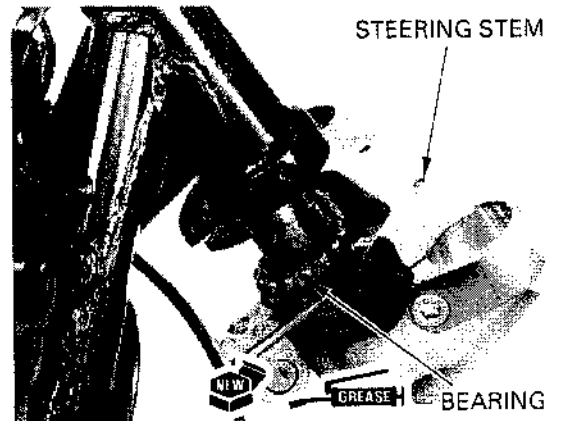

Apply grease to the new upper bearing.  
Install the upper bearing, upper bearing inner race, dust seal and steering top thread.

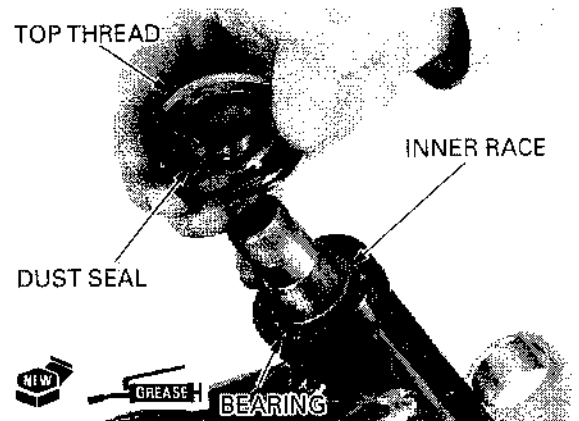

Tighten the top thread to the specified torque.

**TOOL:**  
**Steering stem socket**      07916-3710100

**TORQUE:** 25 N·m (2.5 kgf·m , 18 lbf·ft)

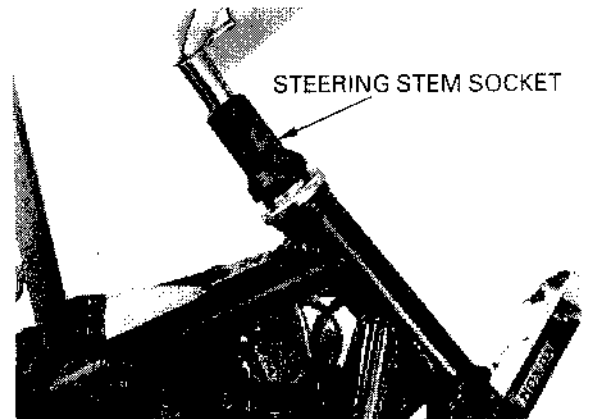

Turn the steering stem right and left, lock-to-lock at least five times to seat bearings.  
Make sure that the steering stem moves smoothly, without play or binding.

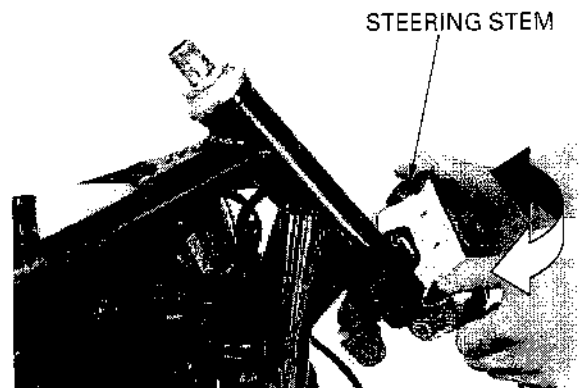

## FRONT WHEEL/SUSPENSION/STEERING

Retighten the top thread to the specified torque.

**TOOL:**

**Steering stem socket**      07916-3710101

**TORQUE:** 25 N·m (2.5 kgf·m , 18 lbf·ft)

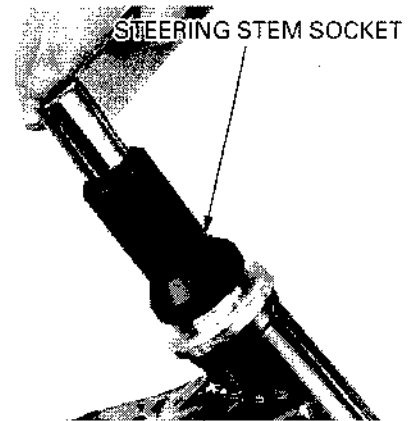

Install the new lock washer and bend the two opposite tabs down into the grooves in the adjustment nut.

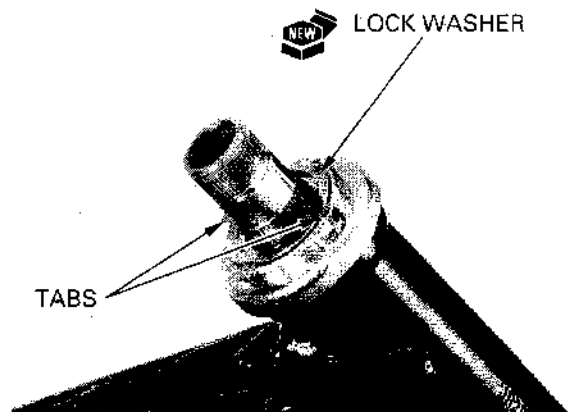

Install and finger tighten the lock nut all the way. Hold the steering top thread and further tighten the lock nut, within 90 degrees, to align its grooves with the tabs of the lock washer. Bend up the lock washer tabs into the grooves of the lock nut.

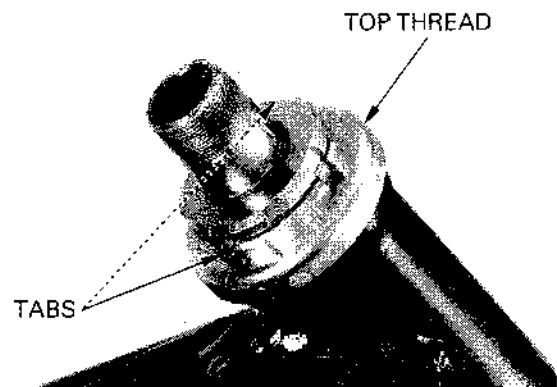

Install the speedometer stay and bolts to the top bridge. Tighten the bolts securely.

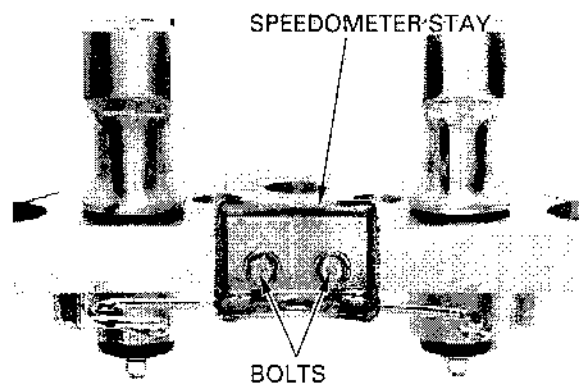

Install the indicator panel and screws.  
Tighten the screws securely.

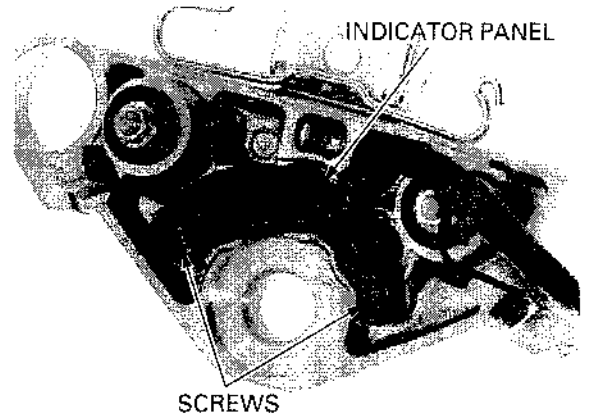

Install the top bridge.  
Install the fork legs (page 13-33).  
Install the washer.

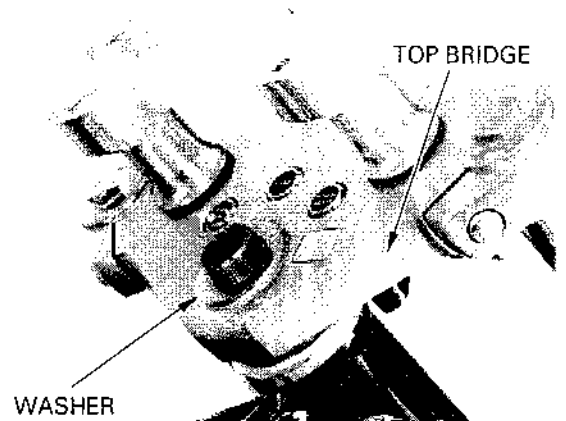

Install and tighten the steering stem nut to the specified torque.

**TORQUE:** 103 N·m (10.5 kgf·m , 76 lbf·ft)

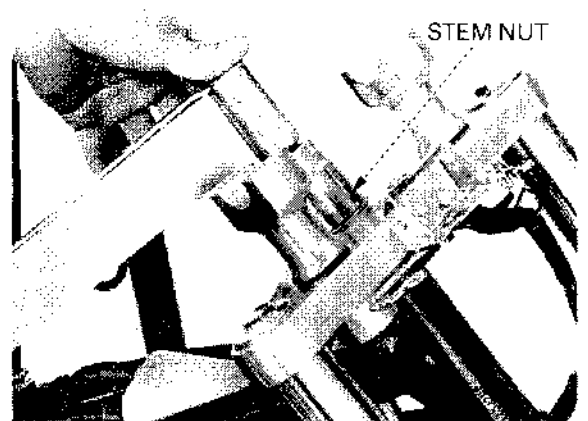

Install the headlight stay and head light with bolt.  
Install and tighten the nuts securely.

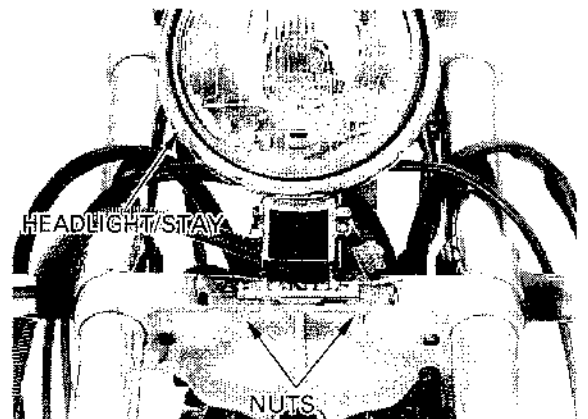

## FRONT WHEEL/SUSPENSION/STEERING

Install the speedometer stay and speedometer.  
Install and tighten the bolt and nut.

Connect the speedometer cable to the speedometer.

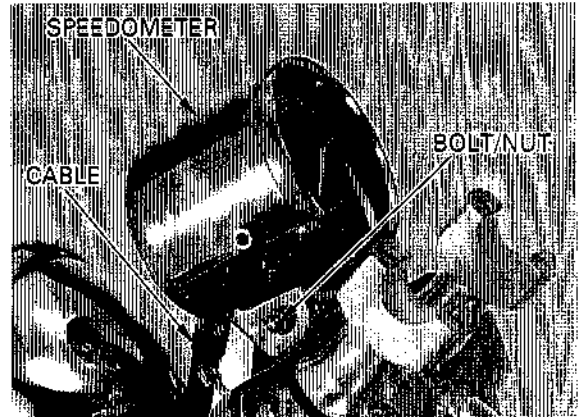

Connect the speedometer 6P (Black) connector.

Install the steering cover (page 2-3).  
Install the handlebar (page 13-9).

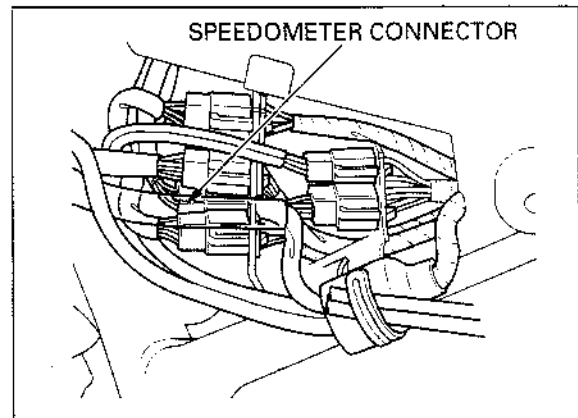

### STEERING BEARING PRELOAD

Raise the front wheel off the ground.  
Position the steering stem to the straight ahead position.  
Hook a spring scale to the fork tube between the fork top and bottom bridges.  
Make sure that there is no cable or wire harness interference.  
Pull the spring scale keeping the scale at a right angle to the steering stem.  
Read the scale at the point where the steering stem just starts to move.

#### STEERING BEARING PRELOAD:

0.9 – 1.4 kgf (2.0 – 3.1 lbf)

If the readings do not fall within the limits, readjust the steering top thread.

Install the removed parts in the reverse order of removal.

#### NOTE:

Route the cables and wire harness properly (page 2-20).

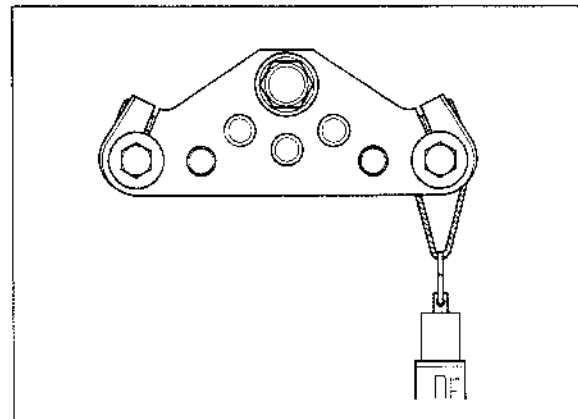

---

MEMO

---

# REAR WHEEL/BRAKE/SUSPENSION

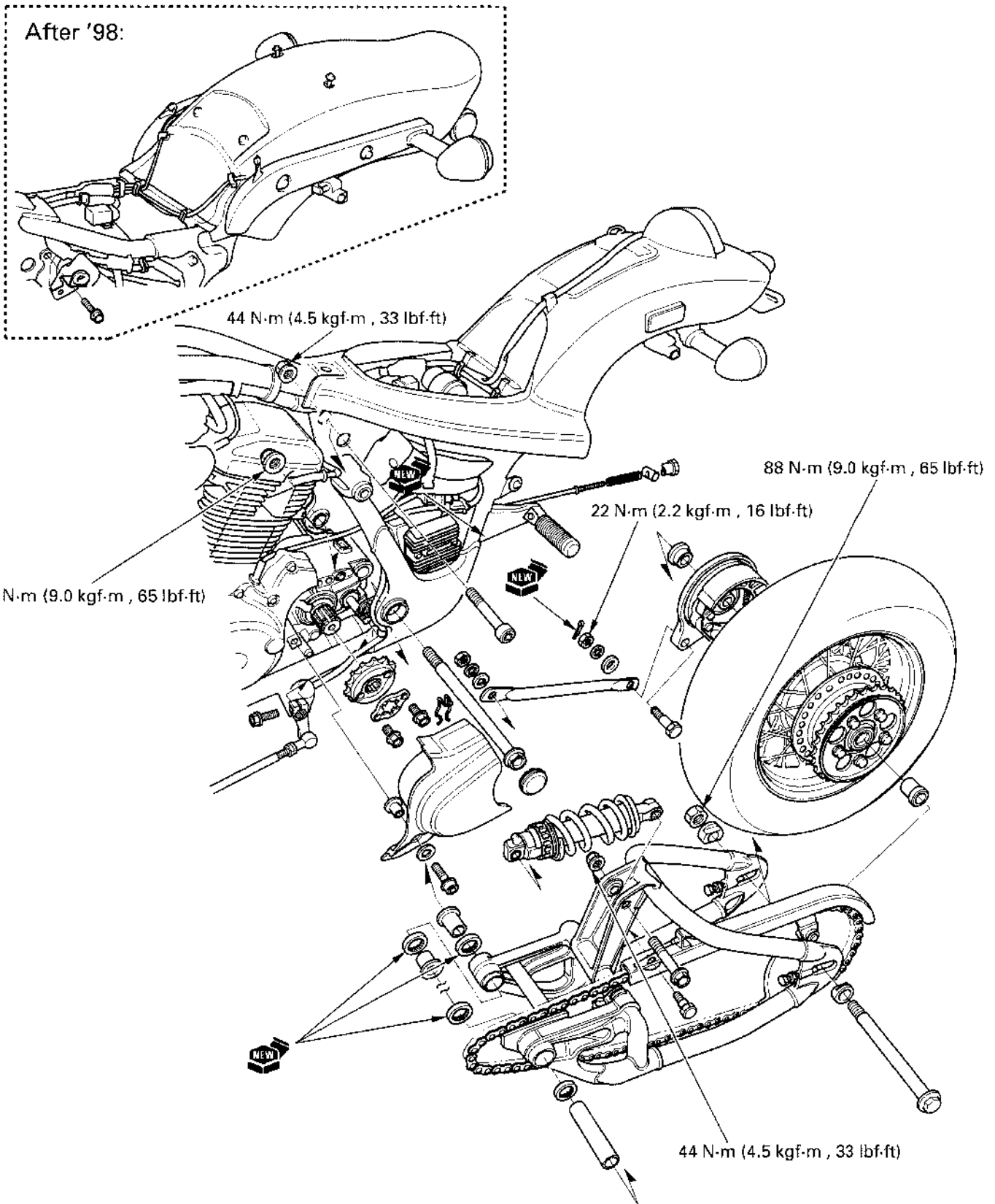



# 14. REAR WHEEL/BRAKE/SUSPENSION

SERVICE INFORMATION	14-1	BRAKE PEDAL	14-14
TROUBLESHOOTING	14-2	SHOCK ABSORBER	14-18
REAR WHEEL	14-3	SWINGARM	14-22
REAR BRAKE	14-11		

## SERVICE INFORMATION

### GENERAL

#### ▲WARNING

- A contaminated brake drum or shoe reduces stopping power. Discard contaminated shoes and clean a contaminated drum with a high quality brake degreasing agent.
- Riding on damaged rims or spokes impairs safe operation of the vehicle.
- Wheel balance directly affects the stability, handling and overall safety of the motorcycle. Carefully check balance before reinstalling the wheel.

#### CAUTION:

- To avoid damaging the rim when using the tire lever, always use rim protectors.
- Do not jack up the motorcycle using the oil filter.

- When servicing the rear wheel, swingarm or shock absorber, support the motorcycle using a safety stand or hoist.
- Use only genuine Honda replacement bolts and nuts for all suspension pivot and mounting points.

## SPECIFICATIONS

ITEM		STANDARD	SERVICE LIMIT
Minimum tire thread depth			2.0 (0.08)
Cold tire pressure	Up to 90 kg (200 lb) load	200 kPa (2.00 kgf/cm <sup>2</sup> , 29 psi)	
	Up to maximum weight capacity	250 kPa (2.50 kgf/cm <sup>2</sup> , 36 psi)	
Axle runout			0.20 (0.008)
Wheel rim runout	Radial		2.0 (0.08)
	Axial		2.0 (0.08)
Wheel hub-to-rim distance		32.3 ± 0.8 (1.27 ± 0.03)	
Wheel balance weight		Max 70 g (2.5 oz)	
Drive chain slack		20 - 30 (3/4 - 1-1/4)	50 (2.0)
Drive chain link		120L	
Drive chain size	DID	525 V8	
	RK	525 SM5	
Rear brake	Drum I.D.	160.0 - 160.3 (6.30 - 6.31)	161 (6.3)
	Lining thickness	5 (0.2)	2 (0.1)
Brake pedal free play		20 - 30 (3/4 - 1-1/4)	
Shock absorber spring preload adjuster setting		2nd position	

## REAR WHEEL/BRAKE/SUSPENSION

---

### TORQUE VALUES

Rear axle nut	88 N·m (9.0 kgf·m , 65 lbf·ft)	U-nut
Driven sprocket nut	64 N·m (6.5 kgf·m , 47 lbf·ft)	U-nut
Rear shock absorber mounting nut (upper)	44 N·m (4.5 kgf·m , 33 lbf·ft)	
(lower)	44 N·m (4.5 kgf·m , 33 lbf·ft)	
Swingarm pivot bolt	88 N·m (9.0 kgf·m , 65 lbf·ft)	
Rear brake stopper arm bolt	'97 - '98: 22 N·m (2.2 kgf·m , 16 lbf·ft)	
	After '98: 21 N·m (2.1 kgf·m , 15 lbf·ft)	
Rear brake arm pinch bolt	'97 '98: 26 N·m (2.7 kgf·m , 20 lbf·ft)	
	After '98: 21 N·m (2.1 kgf·m , 15 lbf·ft)	
Rear brake middle rod joint bolt	9 N·m (0.9 kgf·m , 6.5 lbf·ft)	
Spokes	4 N·m (0.4 kgf·m , 2.9 lbf·ft)	
Fuel pump stay mounting nut ('97 - '98) /		
Turn signal relay stay mounting nut (After '98)	9 N·m (0.9 kgf·m , 6.5 lbf·ft)	

### TOOLS

Attachment, 32 × 35 mm	07746 - 0010100	
Attachment, 42 × 47 mm	07746 - 0010300	
Pilot, 15 mm	07746 - 0040300	
Pilot, 17 mm	07746 - 0040400	
Pilot, 22 mm	07746 - 0041000	
Bearing remover shaft	07746 - 0050100	
Bearing remover head, 17 mm	07746 - 0050500	
Attachment, 28 × 30 mm	07946 - 1870100	
Driver	07749 - 0010000	
Snap ring pliers	07914 - 3230001	
Driver shaft set	07946 KA50000	
Driver shaft	07946 - MJ00100	Not available in U.S.A. or 07949 - 3710001 or 07746 - 0040500
Spoke wrench	07JMA - MR60100	or equivalent commercially available in U.S.A.

## TROUBLESHOOTING

### Rear wheel wobbles

- Bent rim
- Worn rear wheel bearings
- Loose or bent spokes
- Faulty tire
- Unbalanced tire or wheel
- Low tire pressure
- Axle not tightened properly
- Chain adjusters not adjusted equally
- Faulty swingarm pivot bearings and bushings
- Bent frame or swingarm

### Wheel turns hard

- Faulty wheel bearings
- Bent rear axle
- Brake drum

### Rear suspension noisy

- Faulty rear shock absorber
- Loose fasteners

### Soft suspension

- Weak spring
- Improper shock absorber spring preload
- Oil and gas leakage from damper unit
- Low tire pressure

### Hard suspension

- Improper shock absorber spring preload
- Bent damper rod
- High tire pressure
- Damaged swingarm pivot bearings and bushings
- Bent frame or swingarm

### Poor brake performance

- Improper brake adjustment
- Worn brake shoes
- Brake linings oily, greasy or dirty
- Worn brake cam
- Worn brake drum
- Brake arm serrations improperly engaged
- Brake shoes worn at cam contact area

## REAR WHEEL

### REMOVAL

**CAUTION:**

*Do not jack up the motorcycle using the oil filter.*

Support the motorcycle using a hoist or a jack under the engine.

Loosen the axle nut.

Loosen the drive chain adjusters on both sides of the swingarm.

Disconnect the brake rod from the brake arm.

Remove the cotter pin, nut, washers and bolt from the stopper arm on the brake panel.

Remove the drive chain from the driven sprocket.

Remove the axle nut, adjuster collars, side collar and rear axle.

Remove the rear wheel.

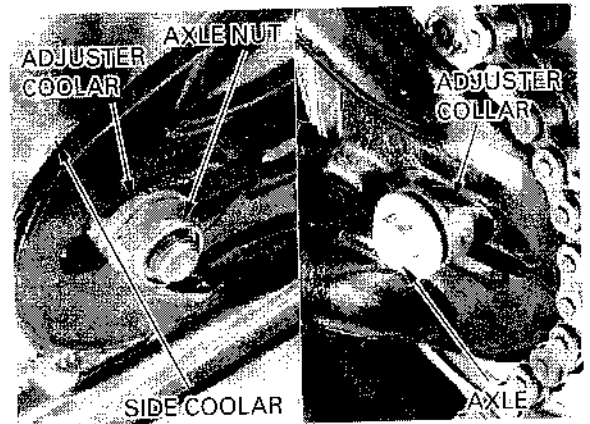
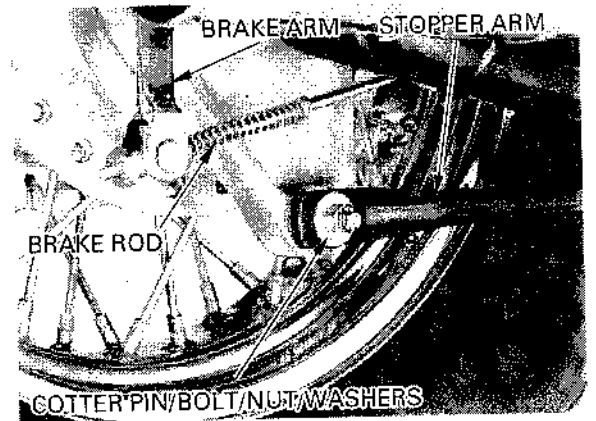
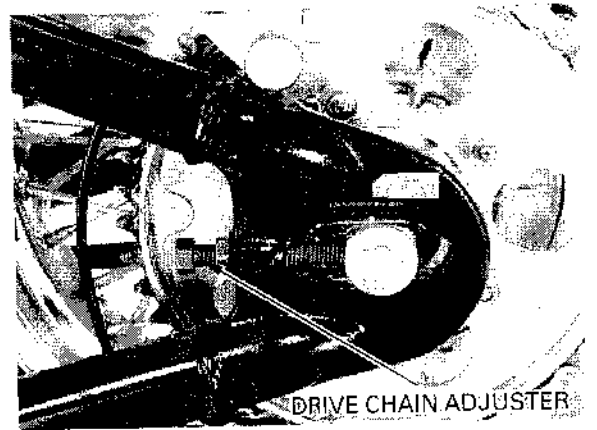

### INSPECTION

#### AXLE

Place the axle in V-blocks and measure the runout. Actual runout is 1/2 the total indicator reading.

**SERVICE LIMIT:** 0.20 mm (0.008 in)

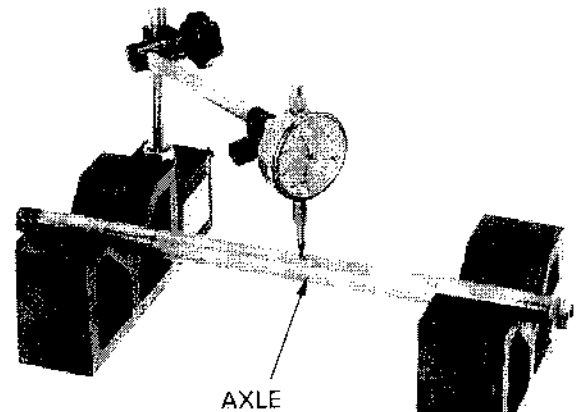

## REAR WHEEL/BRAKE/SUSPENSION

### WHEEL

Check the rim runout by placing the wheel in a turning stand.  
Spin the wheel slowly and read the runout using a dial indicator.  
Actual runout is 1/2 the total indicator reading.

**SERVICE LIMITS:** Radial: 2.0 mm (0.08 in)  
Axial: 2.0 mm (0.08 in)

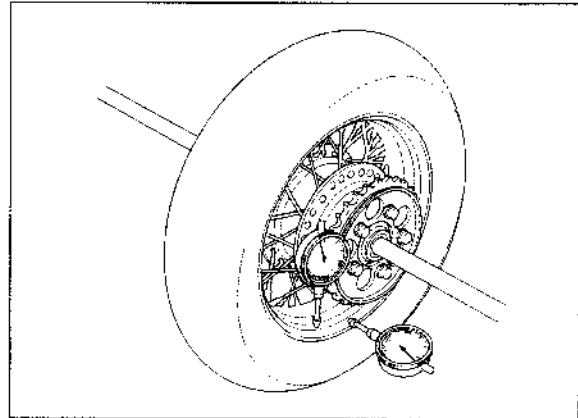

### WHEEL BEARING

Turn the inner race of each bearing with your finger. Bearings should turn smoothly and quietly. Also check that the bearing outer race fits tightly in the hub.

*Replace the wheel bearings in pairs.*

Remove and discard the bearings if the races do not turn smoothly and quietly, or if they fit loosely in the hub.

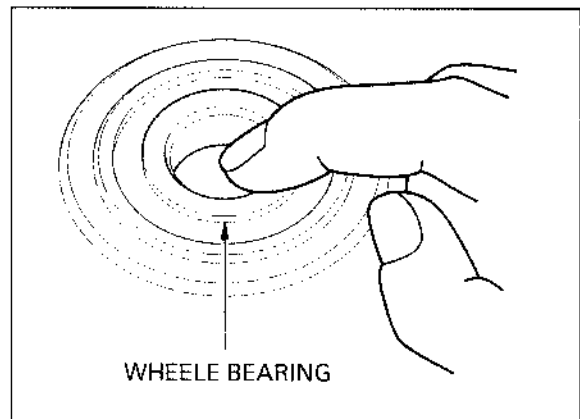

### DRIVEN SPROCKET

Check the condition of the final driven sprocket teeth.  
Replace the sprocket if worn or damaged.

#### NOTE:

- If the final driven sprocket requires replacement, inspect the drive chain and drive sprocket.
- Never install a new drive chain on a worn sprocket or a worn chain on new sprockets. Both chain and sprocket must be in good condition or the replacement chain or sprocket will wear rapidly.

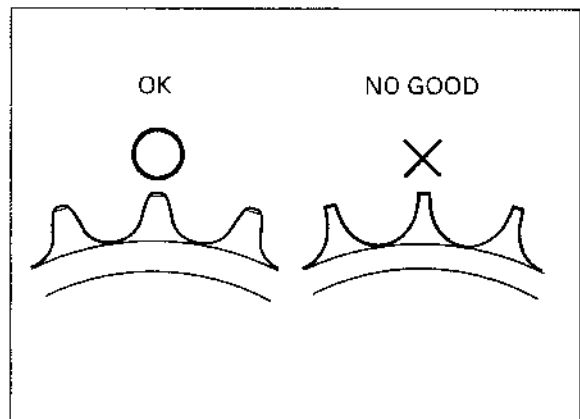

### DISASSEMBLY

Remove the brake panel assembly from the right wheel hub.

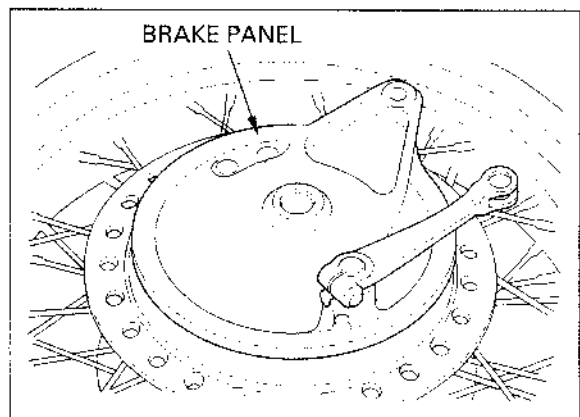

Remove the collar.

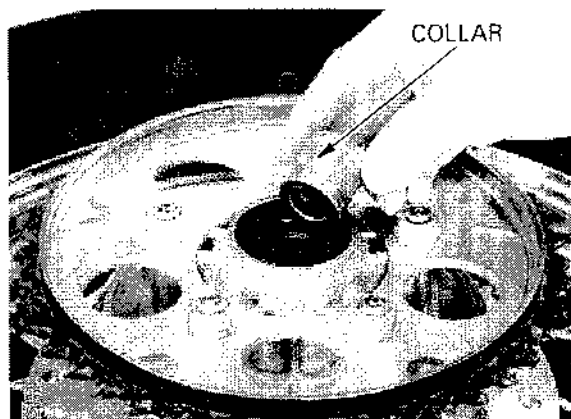

Remove the driven flange from the left wheel hub.

**NOTE:**

If you will be disassembling the driven flange, loosen the driven sprocket nuts before removing the driven flange from the wheel hub.

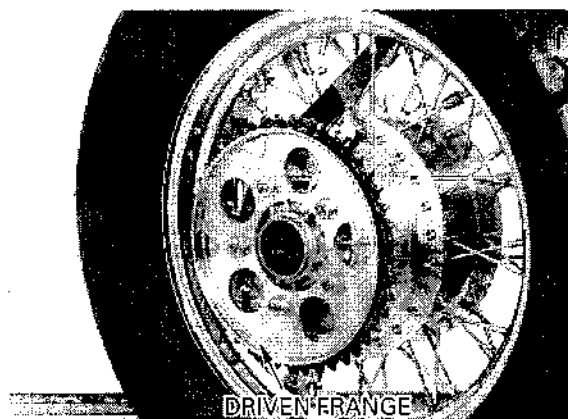

Remove the damper rubbers and O-ring.

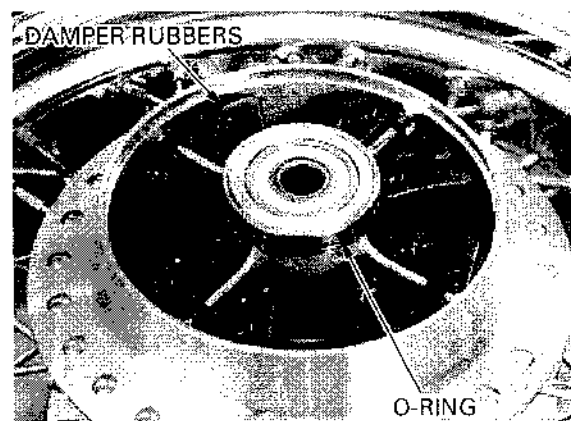

**DRIVEN FLANGE BEARING REMOVAL**

Remove the dust seal.

Remove the driven sprocket nuts and driven sprocket.

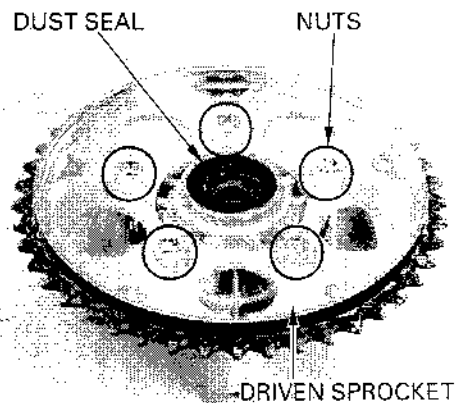

## REAR WHEEL/BRAKE/SUSPENSION

Remove the driven flange collar.

Remove the driven flange bearing.

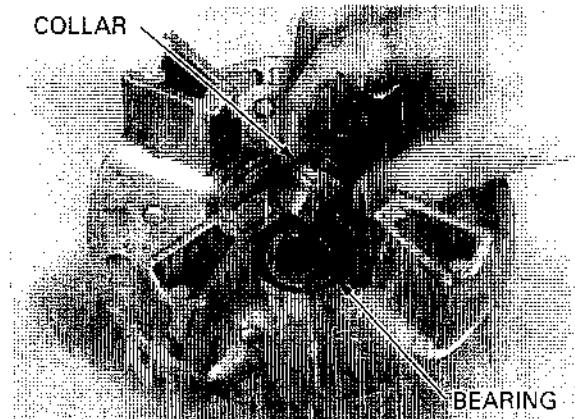

### WHEEL BEARING REMOVAL

Install the bearing remover head into the bearing. From the opposite side install the bearing remover shaft and drive the bearing out of the wheel hub. Remove the distance collar and drive out the other bearing.

#### TOOLS:

Bearing remover shaft  
Bearing remover head,  
17 mm

07746-0050100  
07746-0050500

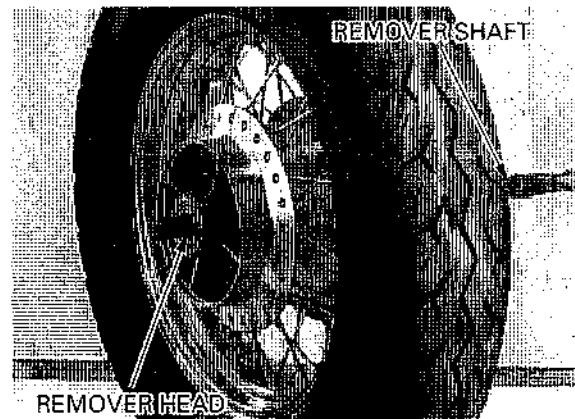

## ASSEMBLY

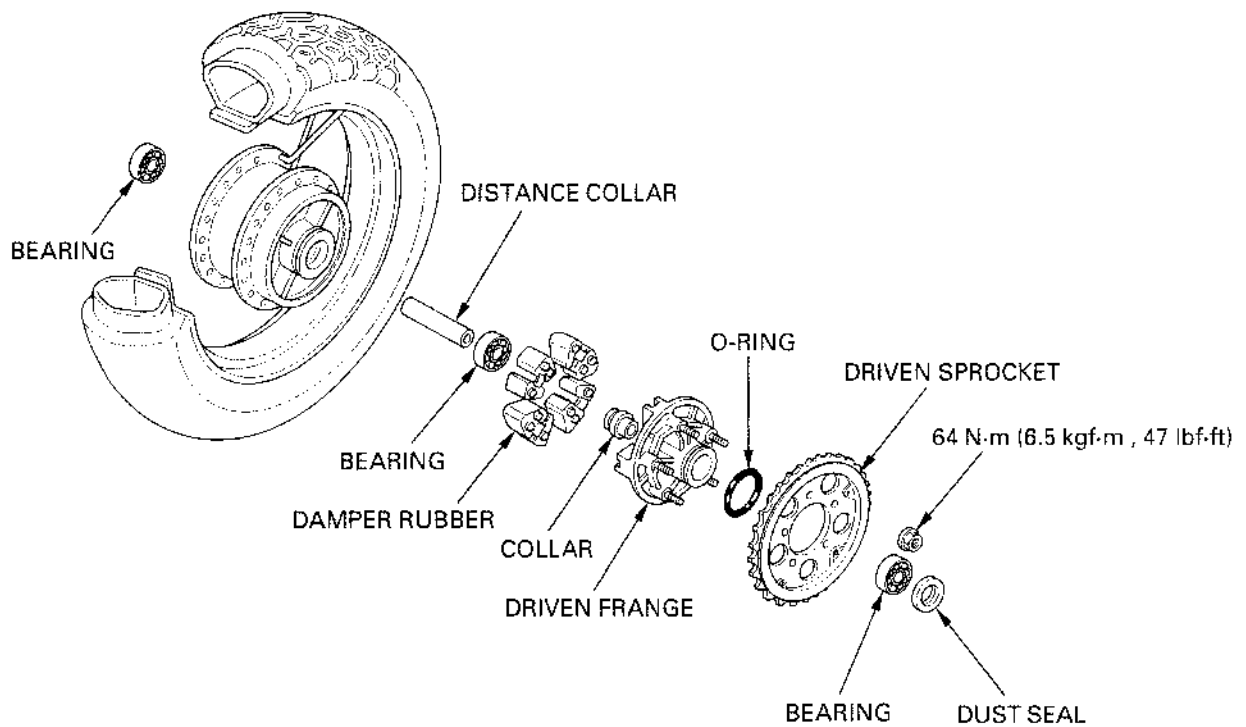

**WHEEL BEARING INSTALLATION**

Pack all bearing cavities with grease.

**CAUTION:**

*Never install an old bearing has been removed, the bearing must be replaced with a new one.*

Drive a new left bearing squarely with its sealed side facing out.  
Install the distance collar, then drive in the right side bearing with its sealed side facing out.

**TOOLS:**

- Driver** 07749-0010000
- Attachment, 42 × 47 mm** 07746-0010300
- Pilot, 17 mm** 07746-0040400

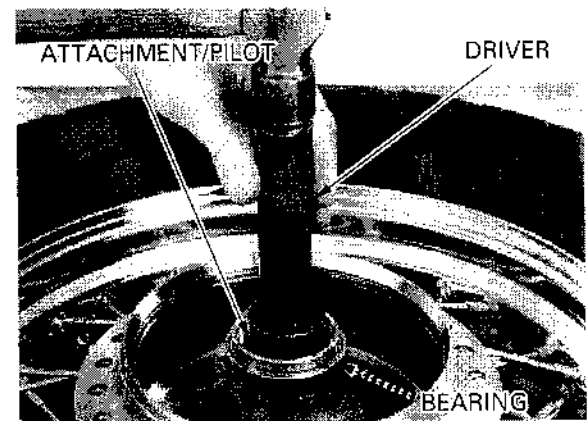
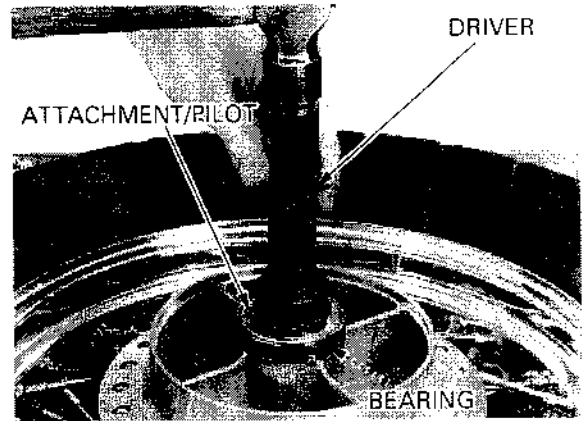

**DRIVEN FLANGE BEARING INSTALLATION**

Drive a new driven flange bearing into the driven flange using the special tools.

**TOOLS:**

- Driver** 07749-0010000
- Attachment, 42 × 47 mm** 07746-0010300
- Pilot, 17 mm** 07746-0040400

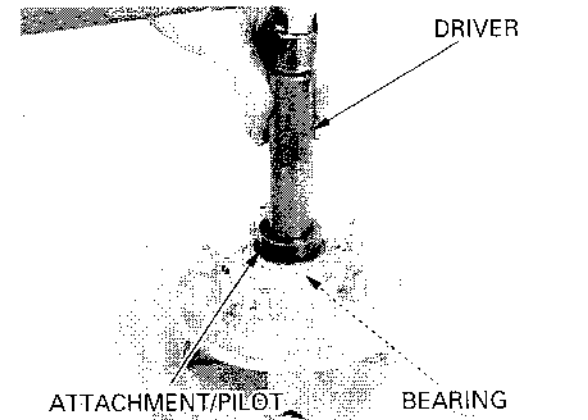

Place the rim on the work bench.  
Place the hub with the left side down and begin lacing with new spokes.

Adjust the hub position so that the distance from the hub right end surface to the side of rim as shown.

**STANDARD:** 23.5 ± 0.8 mm (0.93 ± 0.03 in)

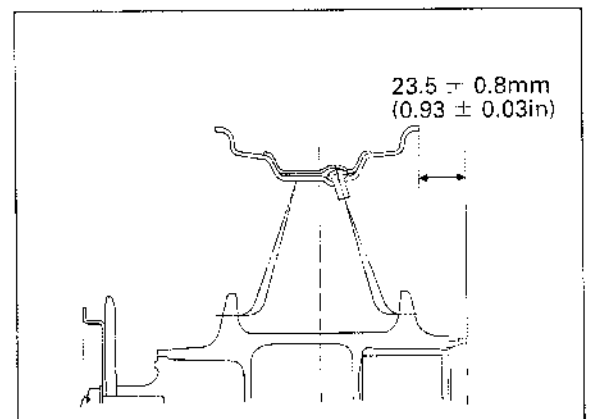

## REAR WHEEL/BRAKE/SUSPENSION

### TOOLS:

Spoke wrench

07JMA – MR60100 or equivalent commercially available in U.S.A.

Torque the spokes in 2 or 3 progressive steps.

**TORQUE:** 4 N·m (0.4 kgf·m, 2.9 lbf·ft)

Check the rim runout (page 14-4).

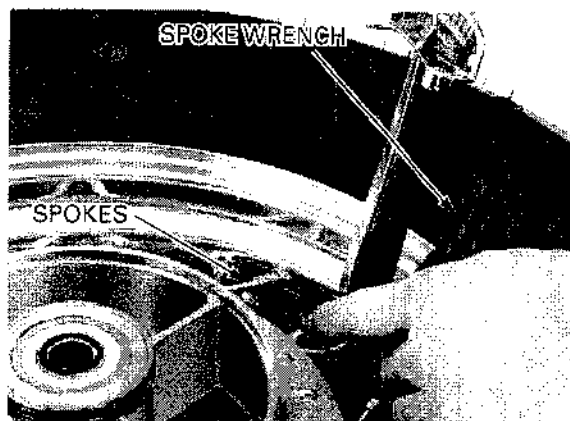

Apply grease to the new dust seal lips, then install it into the driven flange.

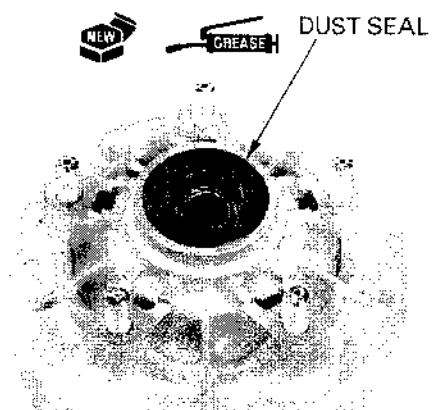

Install the driven flange collar.

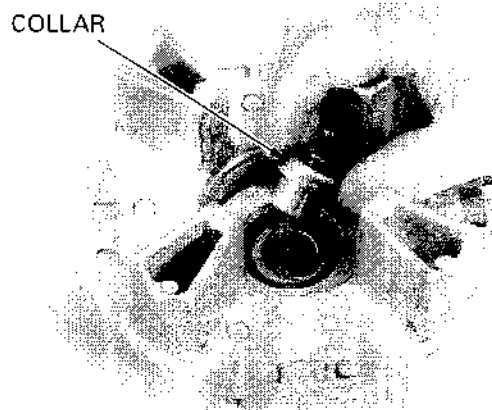

Install the wheel damper rubbers and O-ring into the wheel hub.

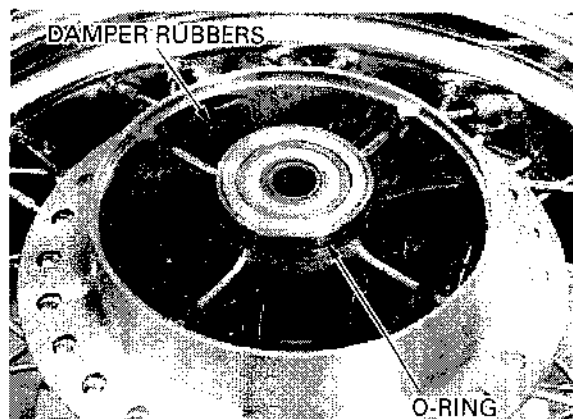



**⚠ WARNING**

*Do not get grease on the brake drum or stopping power will be reduced.*

Install the driven flange assembly into the left wheel hub.  
If the driven sprocket was removed, install the driven sprocket and tighten the nuts.

**TORQUE:** 64 N·m (6.5 kgf·m , 47 lbf·ft)

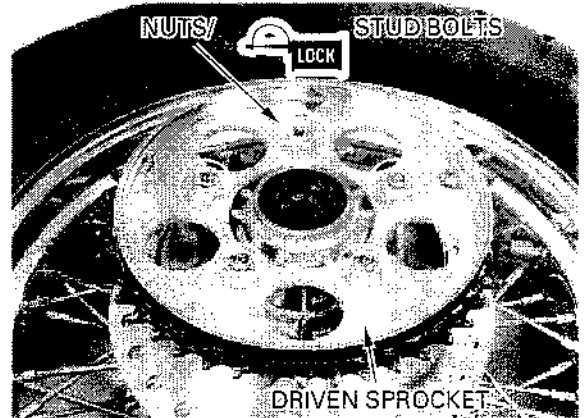

**WHEEL BALANCE**

**⚠ WARNING**

*Wheel balance directly affects the stability, handling and overall safety of the motorcycle. Carefully check balance before reinstalling the wheel.*

**NOTE:**

- The wheel balance must be checked when the tire is remounted.
- For optimum balance, the tire balance mark (a paint dot on the side wall) must be located next to the valve stem. Remount the tire if necessary.



Mount the wheel, and tire assembly on an inspection stand.  
Spin the wheel, allow it to stop, and mark the lowest (heaviest) part of the wheel with chalk.  
Do this two or three times to verify the heaviest area.  
If the wheel is balanced, it will not stop consistently in the same position.

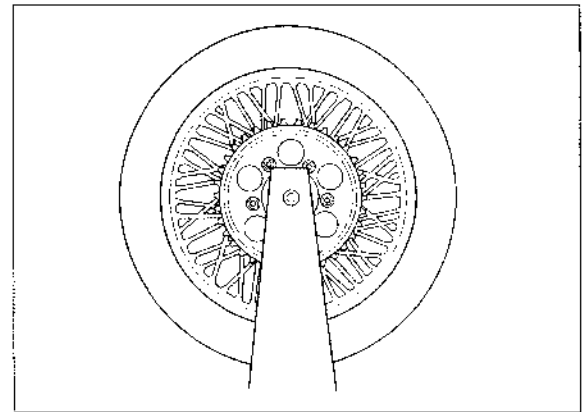

To balance the wheel, install balance weights on the lightest side of rim, the side opposite the chalk marks.  
Add just enough weight so the wheel will no longer stop in the same position when it is spun.  
Do not add more than 70 g (2.5 oz) to the rear wheel.



## REAR WHEEL/BRAKE/SUSPENSION

Install the left side collar.

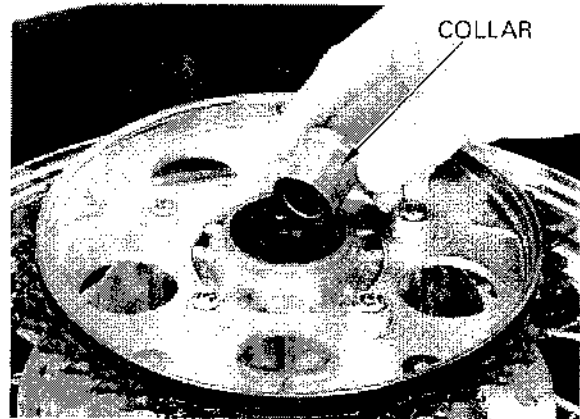

Install the brake panel assembly into the right wheel hub.

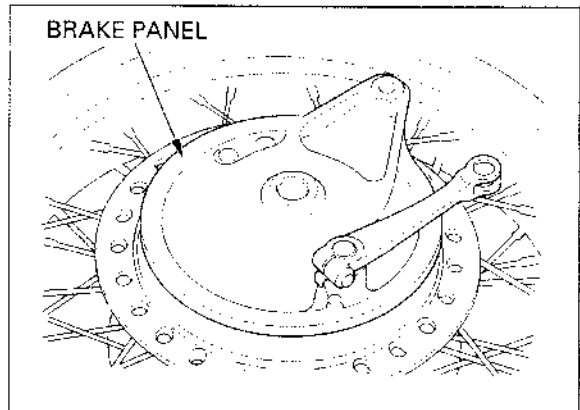

### INSTALLATION

Position the rear wheel in the swingarm.

Install the left side adjuster collar onto the rear axle and insert the axle (from the left side) through the swingarm, wheel hub and right side collar.

Install the drive chain over the driven sprocket.

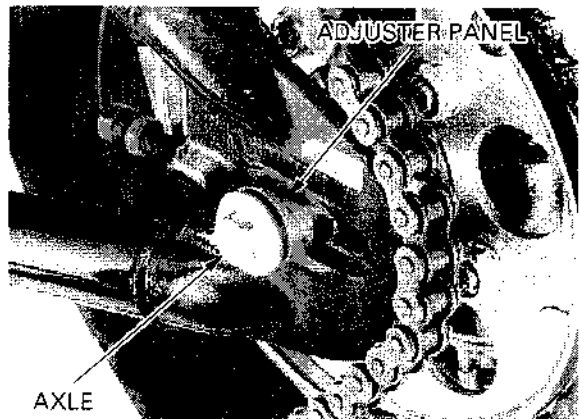

Install the right side adjuster collar and axle nut.

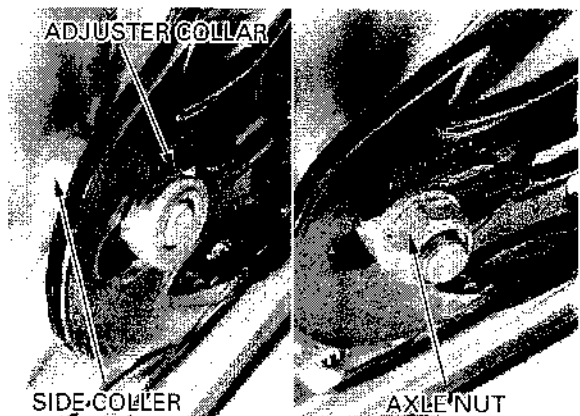

Connect the stopper arm to the brake panel with bolt, seat washer, washer and nut.  
Tighten the nut to the specified torque.

**TORQUE:** '97 - '98: 22 N·m (2.2 kgf·m , 16 lbf·ft)  
After '98: 21 N·m (2.1 kgf·m , 15 lbf·ft)

Install the new cotter pin and bend it back securely.  
Connect the brake rod to the brake arm.

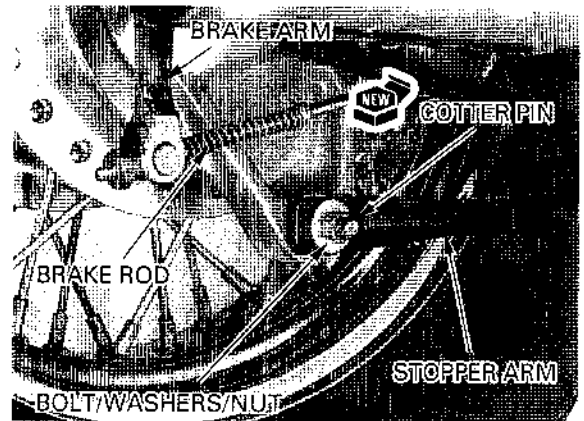

Adjust the drive chain (page 3-21) and rear brake pedal free play (page 3-26).

Tighten the axle nut.

**TORQUE:** 88 N·m (9.0 kgf·m , 65 lbf·ft)

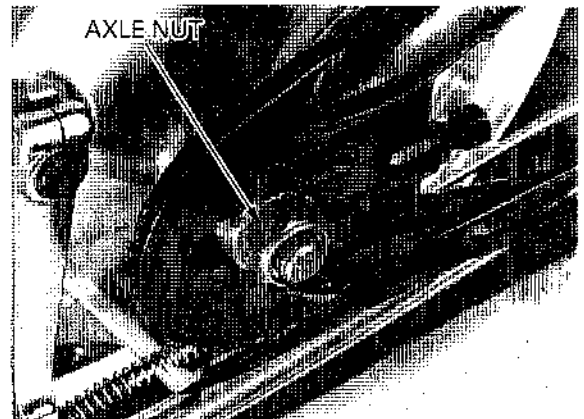

## REAR BRAKE

### REMOVAL

Remove the rear wheel (page 14-3).  
Remove the brake panel from the rear wheel (page 14-4).

### INSPECTION

Measure the brake drum I.D.

**SERVICE LIMIT:** 161 mm (6.3 in)

Measure the brake lining thickness.

**SERVICE LIMIT:** 2 mm (0.1 in)

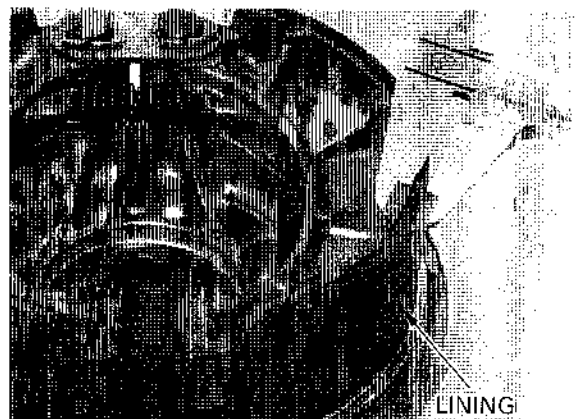
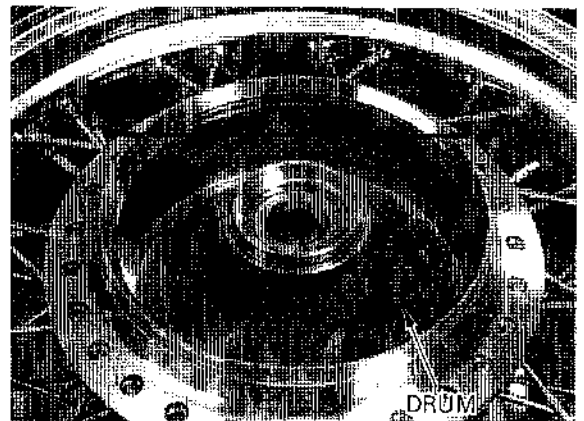

## REAR WHEEL/BRAKE/SUSPENSION

---

### DISASSEMBLY

Remove the cotter pins and set plate.

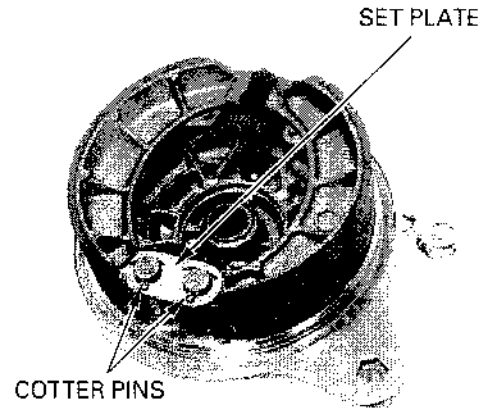

Remove the brake shoes and springs.

#### NOTE:

Mark the shoes to indicate their original positions before removing them.

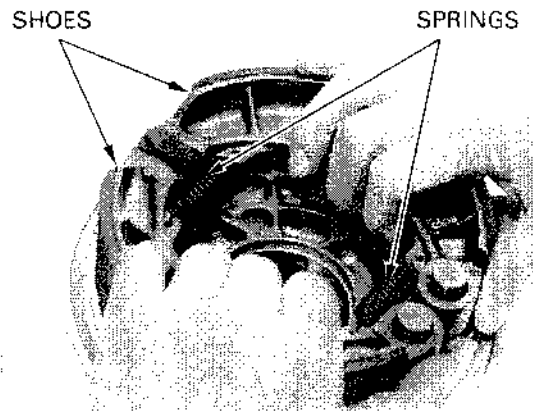

Remove the bolt and brake arm.

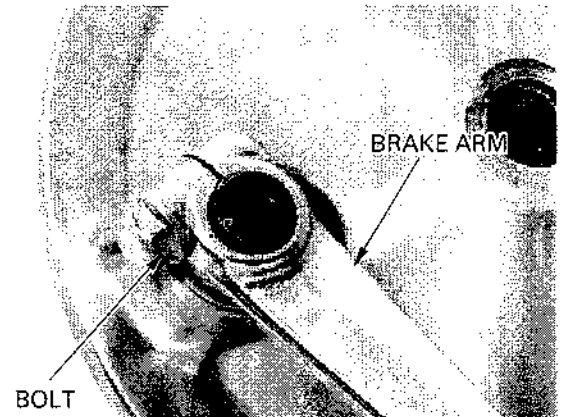

Remove the indicator plate and felt seal.  
Remove the brake cam.

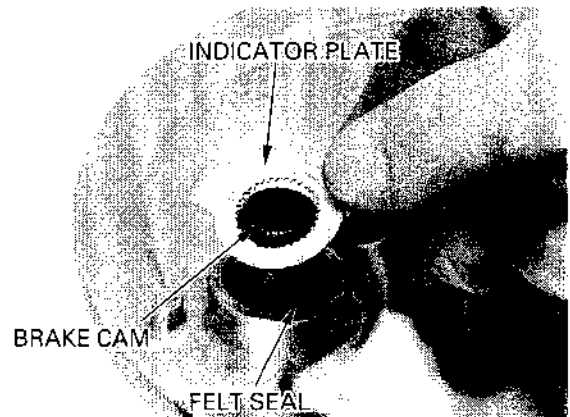

ASSEMBLY

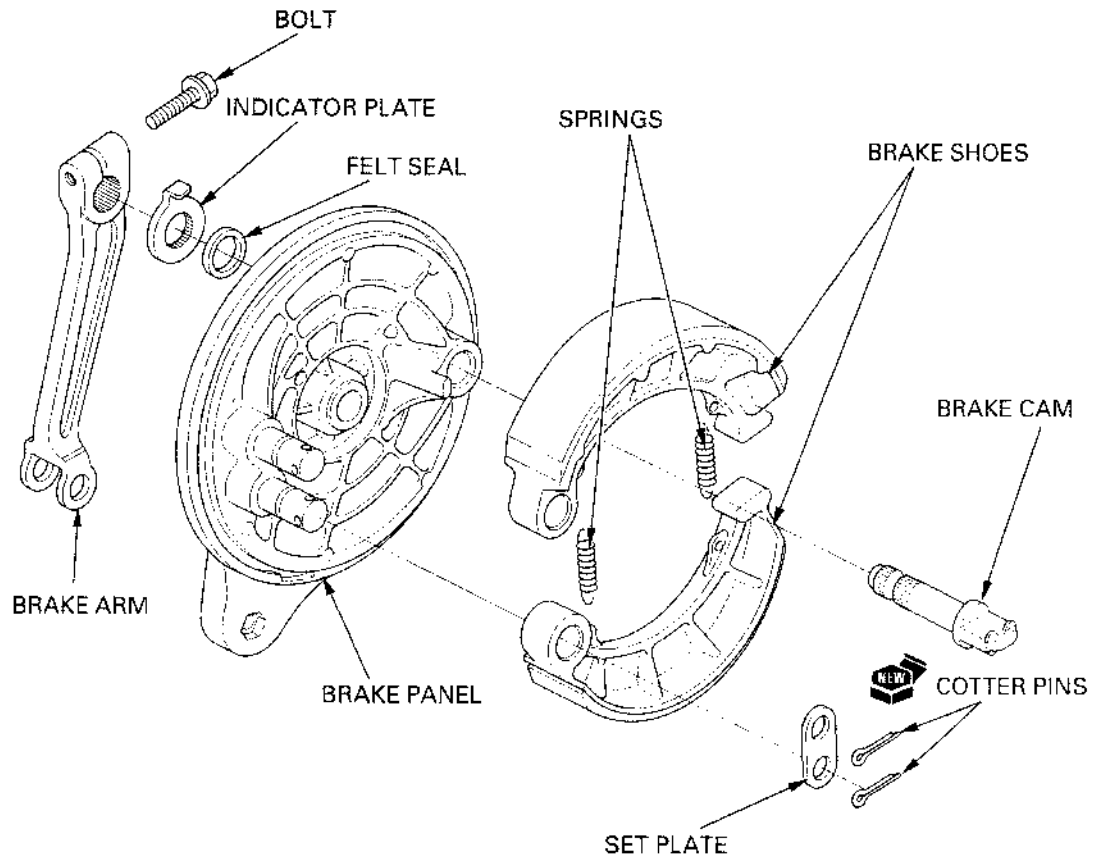

Apply grease to the anchor pins and brake cam. Install the brake cam into the brake panel.

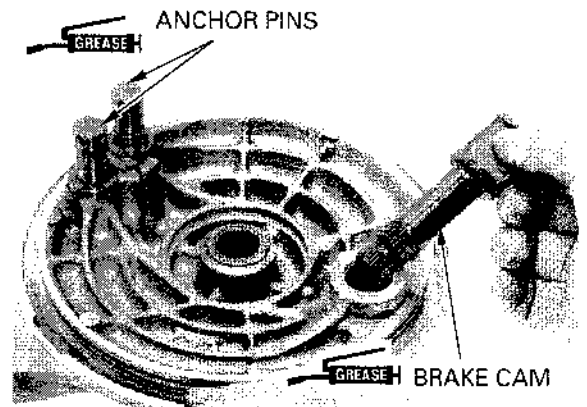

Apply oil to the felt seal and install it onto the brake panel. install the wear indicator plate on the brake cam aligning its wide tooth with the wide groove on the brake cam.

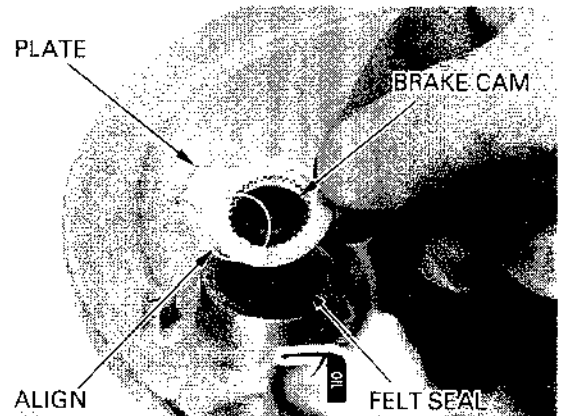

## REAR WHEEL/BRAKE/SUSPENSION

Install the brake arm aligning the punch marks of the arm and the brake cam.  
Install and tighten the brake arm pinch bolt securely.

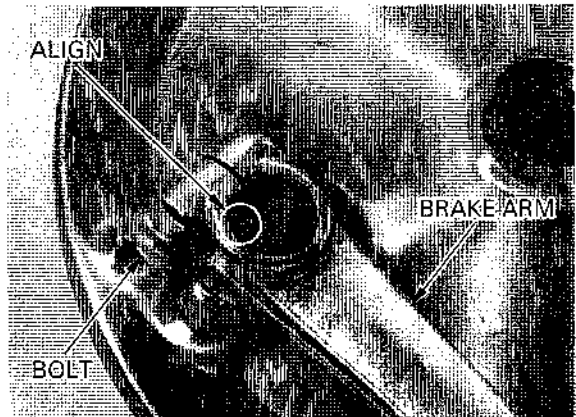

Install the brake shoes and springs.

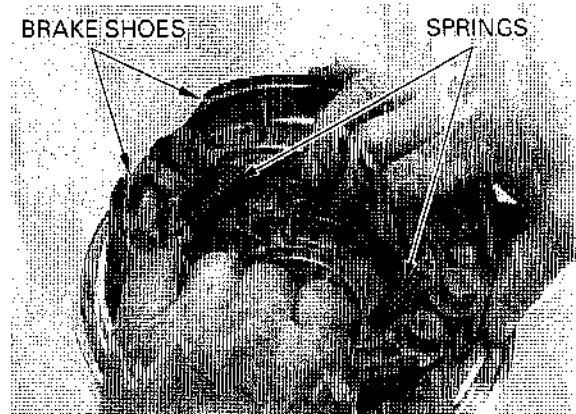

Install the set plate and new cotter pins.

### INSTALLATION

Install the brake panel into the wheel hub (page 14-10).

Install the rear wheel (page 14-10).

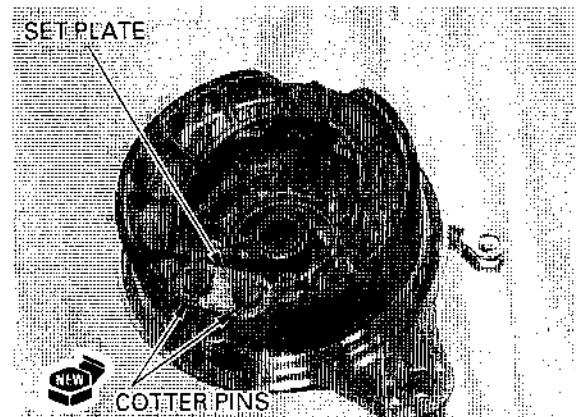

## BRAKE PEDAL

### REMOVAL

#### NOTE:

- If the middle brake rod will be serviced, remove the muffler (page 2-14).
- If the brake rod will be serviced, remove the swingarm (page 14-21).

Remove the cotter pin/washer ('97-'98), nut and middle brake rod front pivot bolt.  
Remove the brake pedal assembly from the middle brake rod.

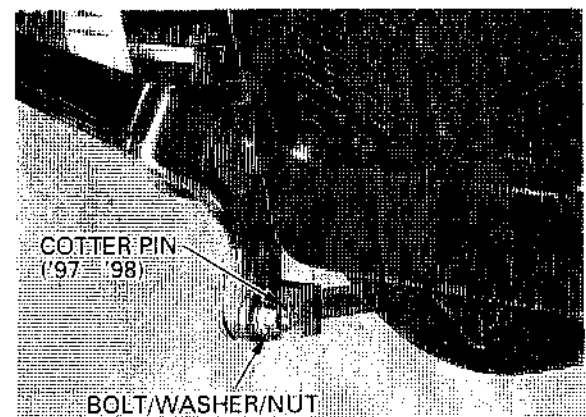

Remove the right footpeg bracket mount bolts, washers and bracket.

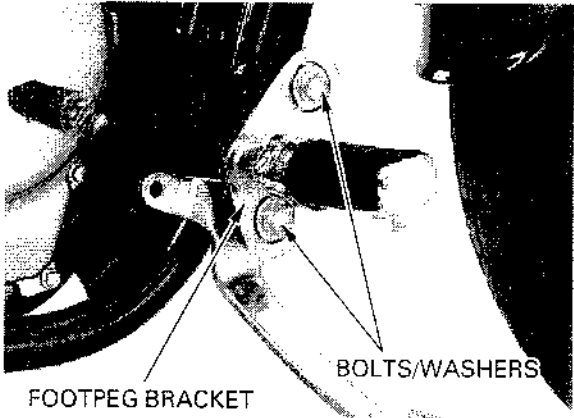

Remove the pivot collar.  
Inspect the brake pedal pivot dust seals wear or damage.  
Replace it if necessary.

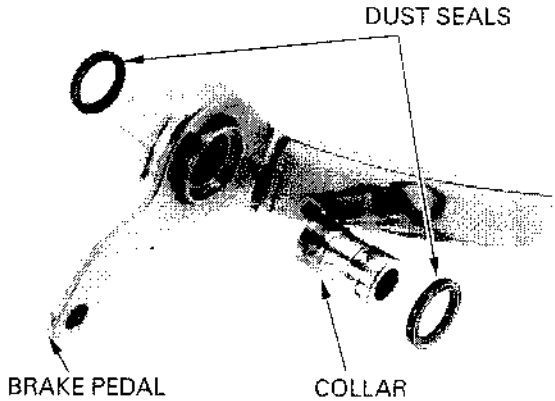

Remove the rear brake light switch return spring.  
Remove the rear brake rod return spring.  
Remove the middle brake arm joint bolt.  
Remove the middle brake arm/brake rod from the brake shaft arm.

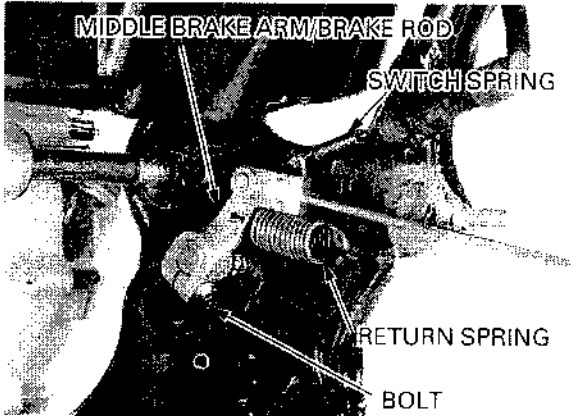

Remove the brake shaft arm and middle brake rod from the frame.

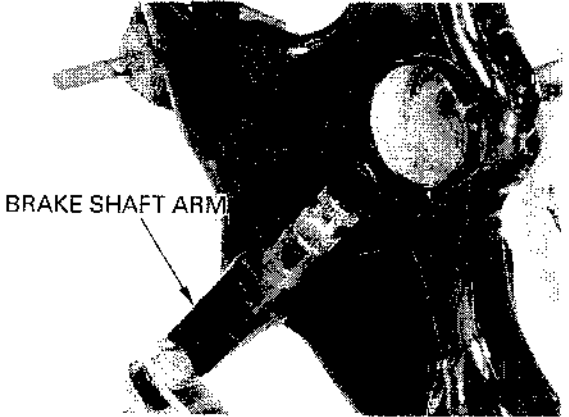

## REAR WHEEL/BRAKE/SUSPENSION

Remove the cotter pin/washer ('97-'98), nut and middle brake rod rear pivot bolt.  
Remove the middle brake rod from the brake shaft arm.

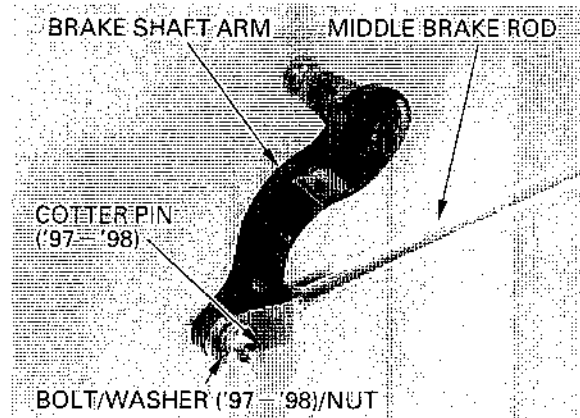

## INSTALLATION

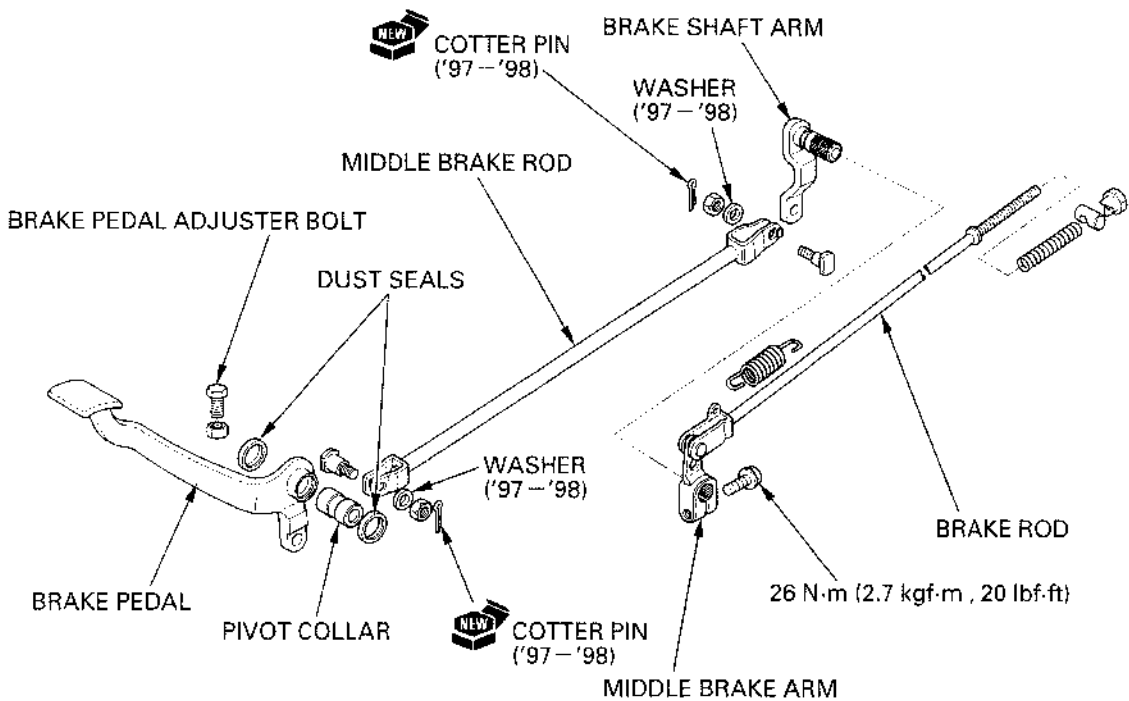

Install the middle brake rod to the brake shaft arm.  
Install the middle brake rod rear pivot bolt, washer ('97-'98) and nut.  
Tighten the nut securely ('97-'98).  
Tighten the nut to the specified torque (After '98).

**TORQUE:** 9 N·m (0.9 kgf·m, 6.5 lbf·ft)

Install the new cotter pin securely to the nut ('97-'98).

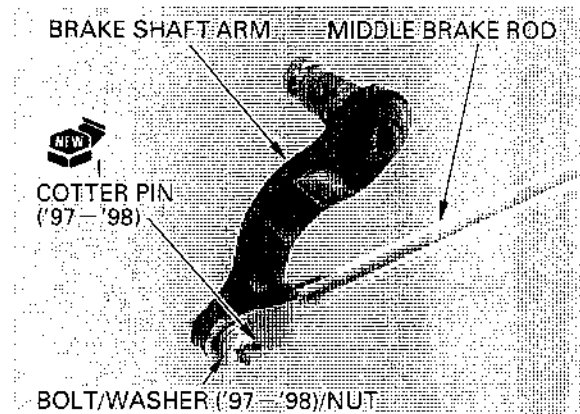



## REAR WHEEL/BRAKE/SUSPENSION

Apply grease to the brake shaft arm pivot.  
Install the brake shaft arm/middle brake rod into the frame.

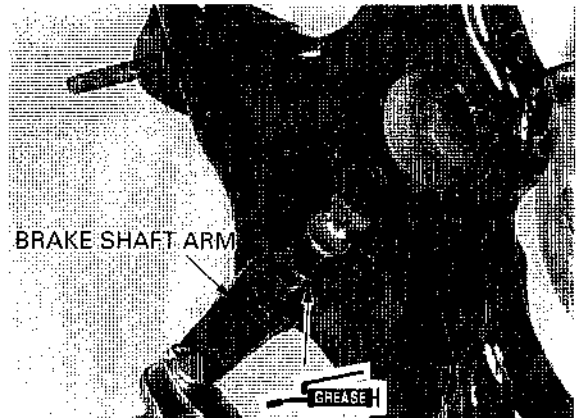

Install the middle brake arm aligning the punch mark on the brake shaft arm with the slit of the middle brake arm.



Install and tighten the middle brake arm joint bolt.

**TORQUE:** '97-'98: 26 N·m (2.7 kgf·m, 20 lbf·ft)  
After '98: 21 N·m (2.1 kgf·m, 15 lbf·ft)

Install the rear brake rod return spring.  
Install the brake light switch spring.

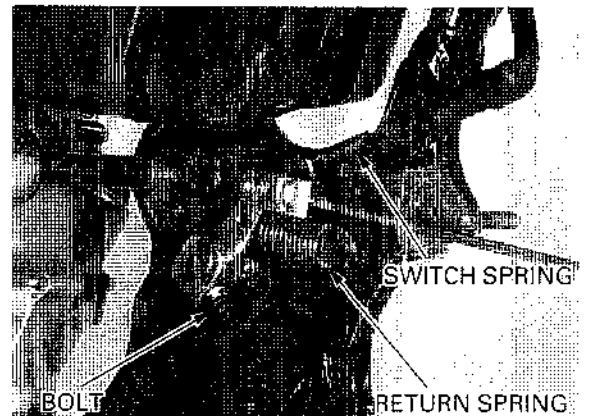

Apply grease to the pivot collar and dust seal lips.  
Install the pivot collar and dust seal into the brake pedal pivot.

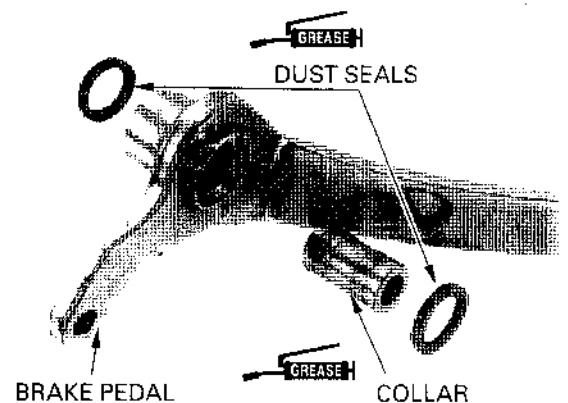

## REAR WHEEL/BRAKE/SUSPENSION

Install the right footpeg, washers and bolts.  
Tighten the bolts to the specified torque.

**TORQUE:** 39 N·m (4.0 kgf·m , 29 lbf·ft)

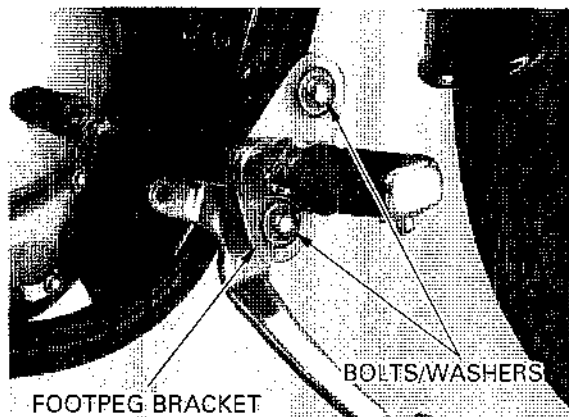

Install the middle brake rod front pivot bolt, washer ('97-'98) and nut.  
Tighten the nut securely ('97-'98).  
Tighten the nut to the specified torque (After '98).

**TORQUE:** 9 N·m (0.9 kgf·m , 6.5 lbf·ft)

Install the new cotter pin securely to the nut ('97-'98).

After installation, adjust the rear brake pedal free play (page 3-26).

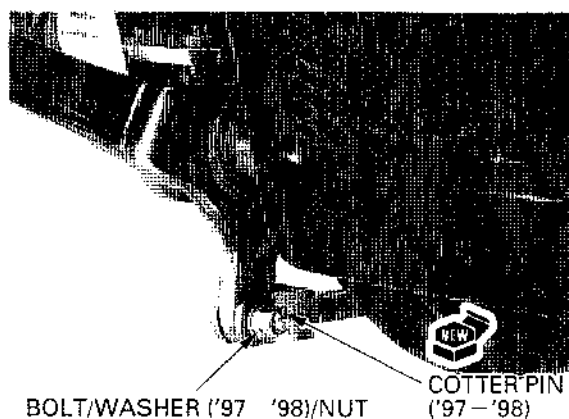

## SHOCK ABSORBER

### REMOVAL

Support the motorcycle securely using a hoist or equivalent.

Remove the following:

- Seat (page 2-2)
- Right and left side cover (page 2-3)
- Rear ignition coil mounting bolts (page 17-8)

'97-'98: Disconnect the fuel pump and fuel pump relay connector.  
Remove the turn signal relay from the fuel pump stay.

After '98: Disconnect the turn signal relay 3P connector.  
Remove the turn signal relay from the stay.

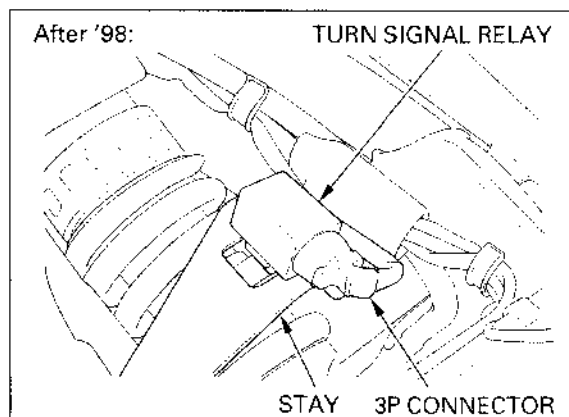
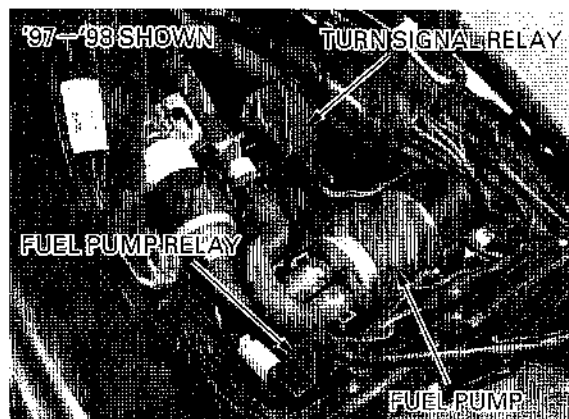

Remove the rear ignition coil stay front side mounting bolt.

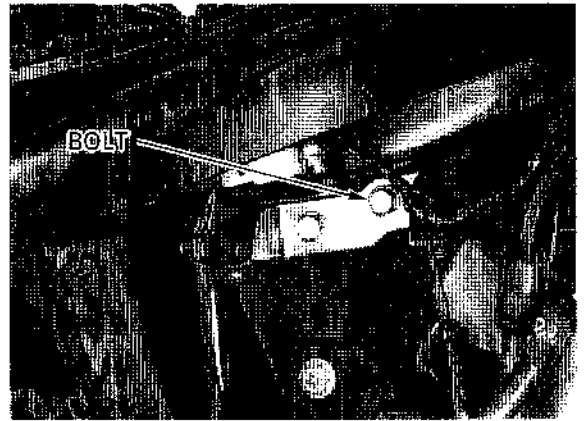

Remove the fuel pump stay ('97-'98)/turn signal relay stay (After '98) mounting nut.

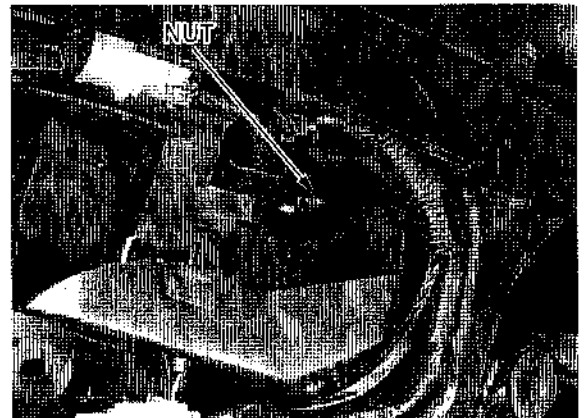

Remove the fuel pump stay ('97-'98).  
Remove the turn signal relay stay (After '98).

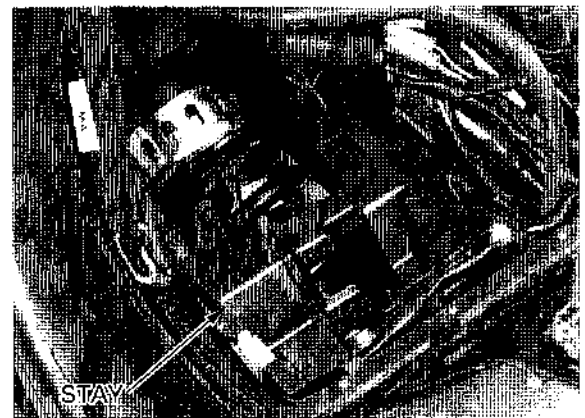

After '98: Remove the side cover upper mount bolt and stay.

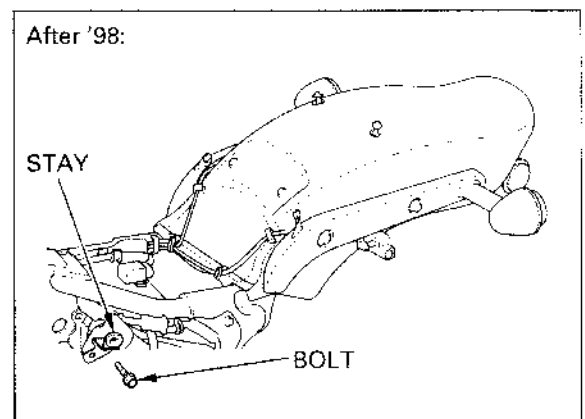

## REAR WHEEL/BRAKE/SUSPENSION

Remove the upper and lower shock absorber mounting bolts and nuts, and remove the shock absorber.

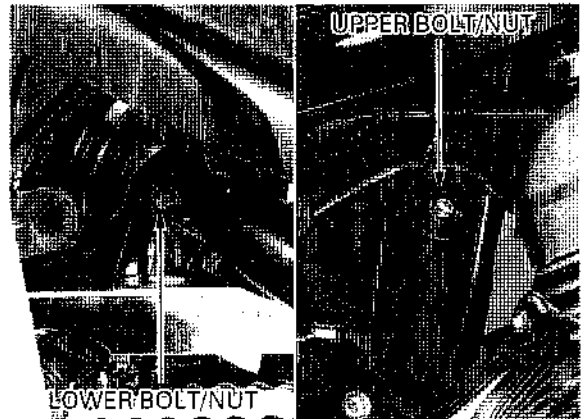

### INSPECTION

Visually inspect the shock absorber for damage. Check the following:

- Damper rod for bend or damage
- Damper unit for deformation or oil leaks
- Upper and lower joint bushings for wear or damage

Check smooth damper operation.

#### CAUTION:

*Do not disassemble the shock absorber. Replace the shock absorber if any component is damaged.*

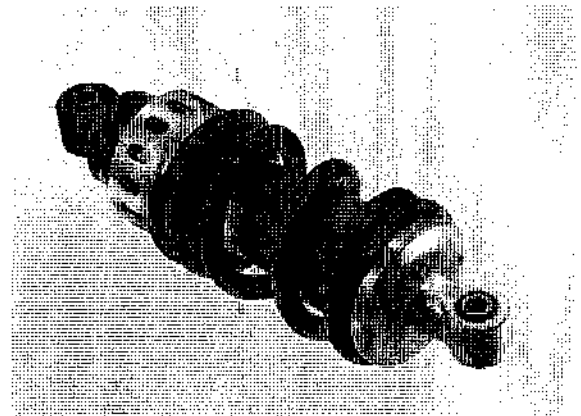

### INSTALLATION

Install and tighten the upper and lower mounting bolts and nuts to the specified torque.

**TORQUE:** 44 N·m (4.5 kgf·m , 33 lbf·ft)

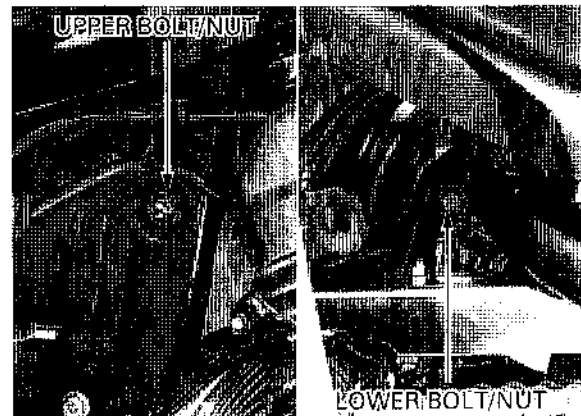

*After '98:* Install the side cover upper mount stay and tighten the bolt securely.

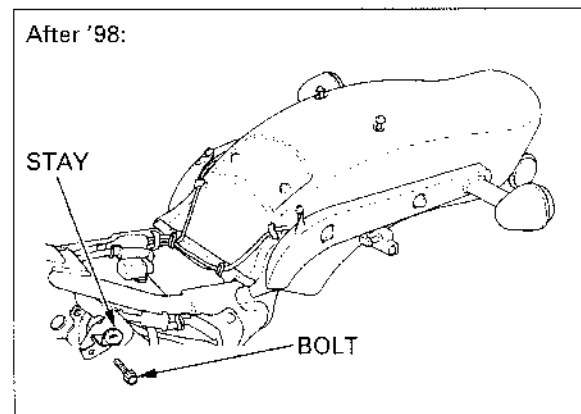

Install the fuel pump stay ('97--'98).  
Install the turn signal relay stay (After '98).

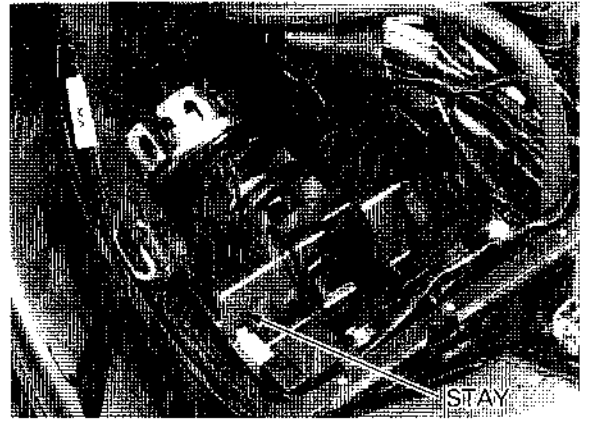

Install the fuel pump stay ('97-'98)/turn signal relay stay (After '98) mounting nut to the specified torque.

**TORQUE:** 9 N-m (0.9 kgf-m , 6.5 lbf-ft)

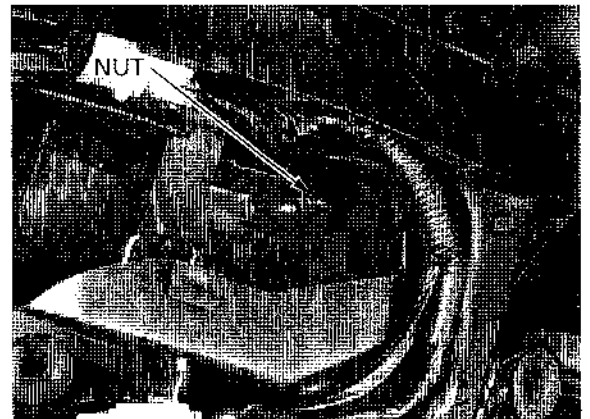

Install and tighten the ignition coil stay front side mounting bolt securely.

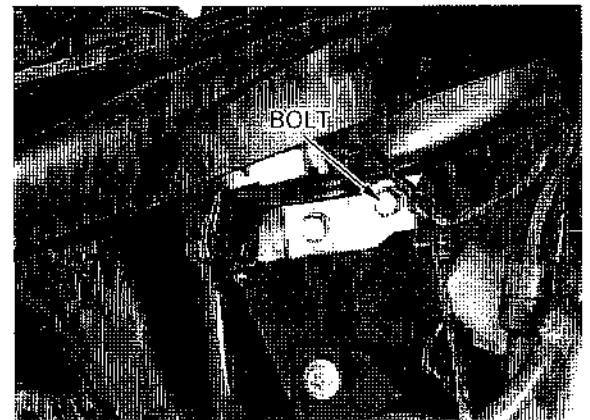

'97-'98: Connect the turn signal relay and fuel pump relay connectors.  
Install the fuel pump onto the fuel pump stay.

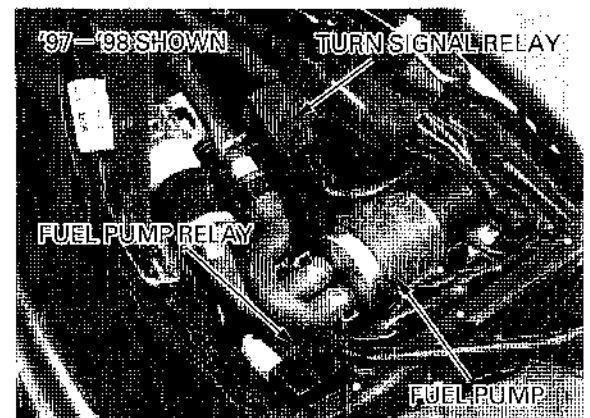

## REAR WHEEL/BRAKE/SUSPENSION

*After '98:* Install the turn signal relay to the stay and connect the turn signal relay 3P connector.

Install the following:

- Rear ignition coil (page 17-8)
- Right and left side cover (page 2-3)
- Seat (page 2-2)

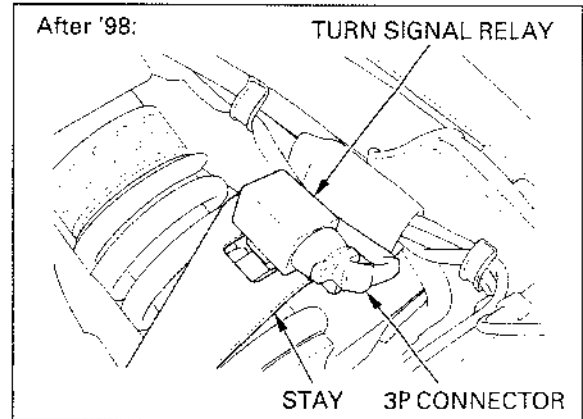

## SWINGARM

### REMOVAL

Remove the followings:

- Rear wheel (page 14-3)
- Drive sprocket (page 7-3)
- Gearshift arm from the gearshift spindle (page 8-12)
- Evaporative emission canister (California type only)
- Radiator coolant reserve tank (page 6-16)

Remove the shock absorber lower mounting bolt and nut.

Remove the swingarm pivot bolt caps.

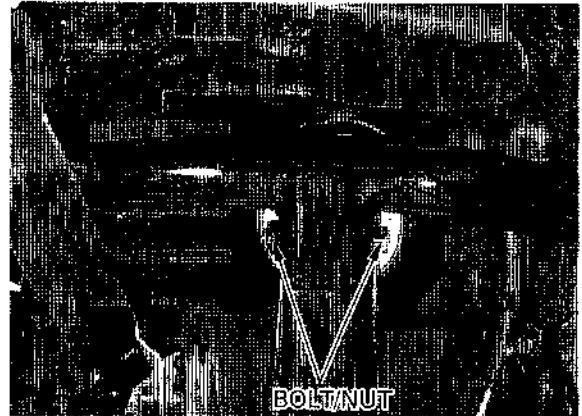

Remove the swingarm pivot bolt and nut, then remove the swingarm from the frame.

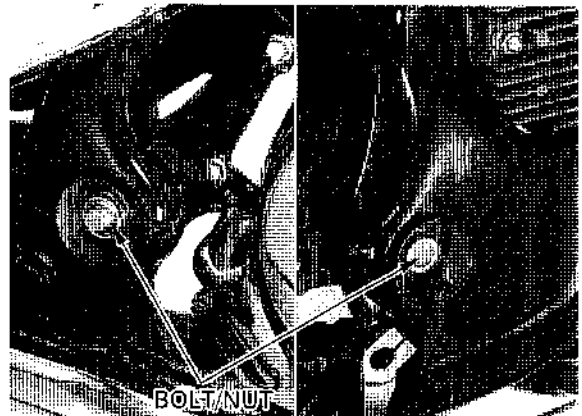

**DISASSEMBLY**

Inspect the drive chain slider for wear or damage.  
Replace it if necessary.  
Inspect the drive chain for dirt or damage.  
Clean or replace it if necessary (page 3-21).

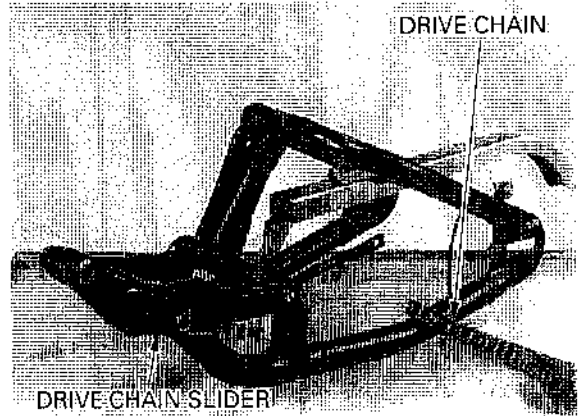

Remove the nuts, bolts, collars and drive chain slider.

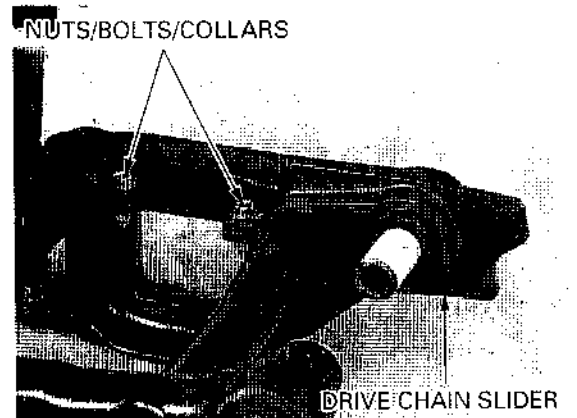

Remove the bolts and drive chain cover.

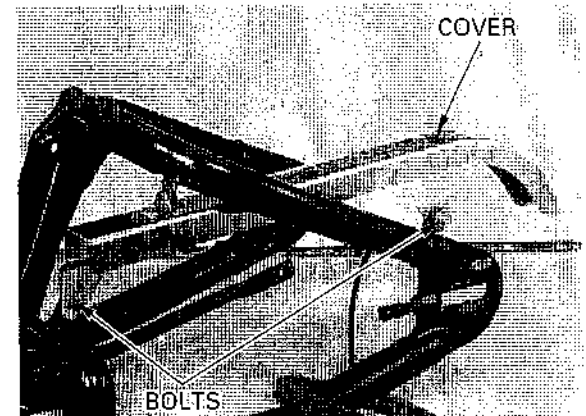

Remove the cotter pin, nut, washers, bolt and stopper arm.

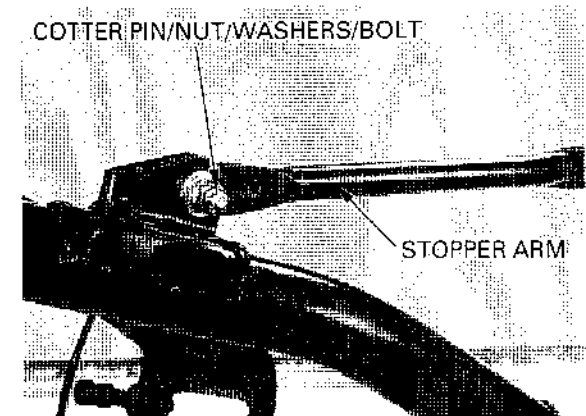

## REAR WHEEL/BRAKE/SUSPENSION

Remove the collars and dust seals from the right side pivot.

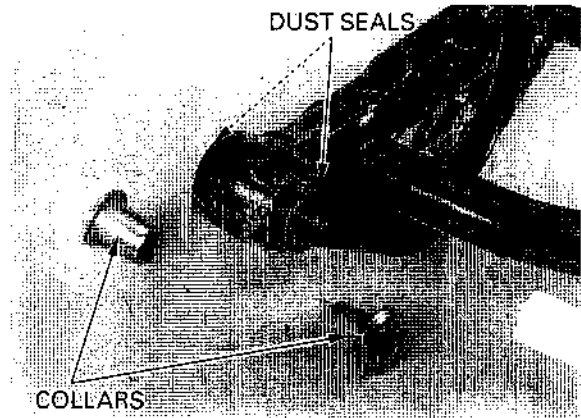

Remove the collar and dust seals from the left side pivot.

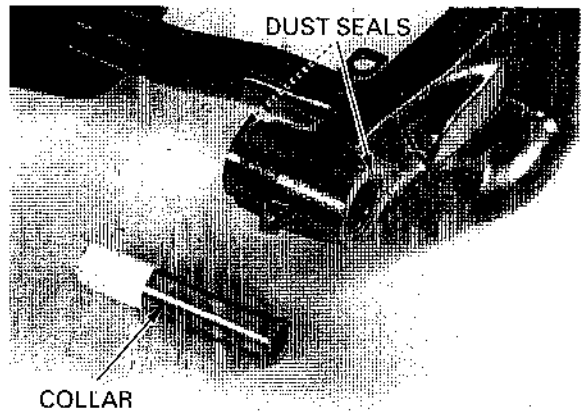

### INSPECTION

Inspect the swingarm for deformation or cracks. Check the pivot bearings, collars and dust seals for wear or damage.

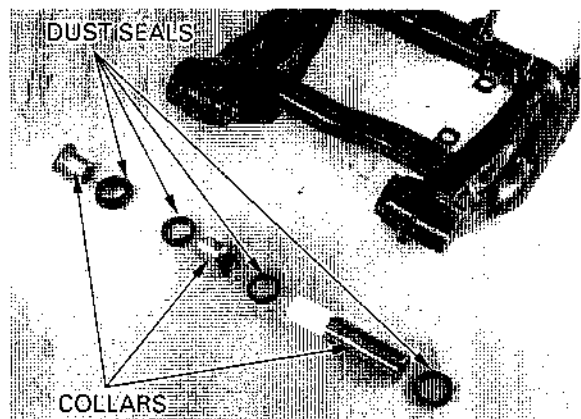

Disassemble the drive chain cover and inspect the chain protector for wear or damage. Replace if necessary.

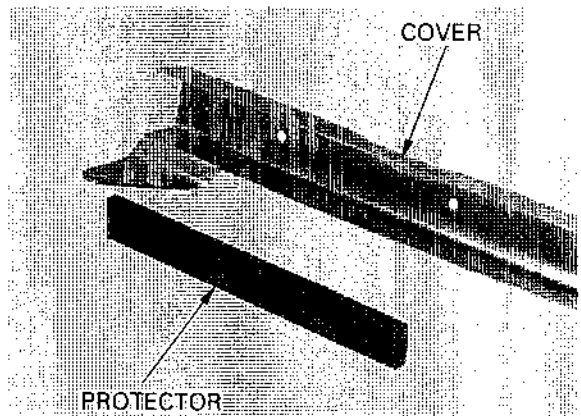



**PIVOT BEARING REPLACEMENT**

Remove the dust seals from the right and left swingarm pivots.  
Remove the snap ring from the right pivot.

**TOOL:**  
Snap ring pliers 07914-3230001

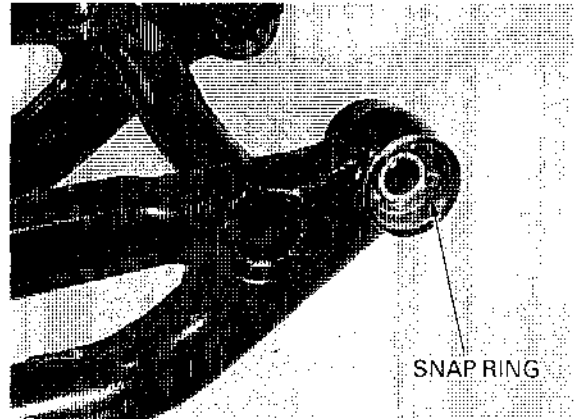

Drive the right pivot ball bearing out of the swingarm using a hydraulic press and driver shaft.

**TOOL:**  
Driver shaft 07946 MJ00100  
Not available in U.S.A.  
or 07949-3710001  
or 07746-0040500

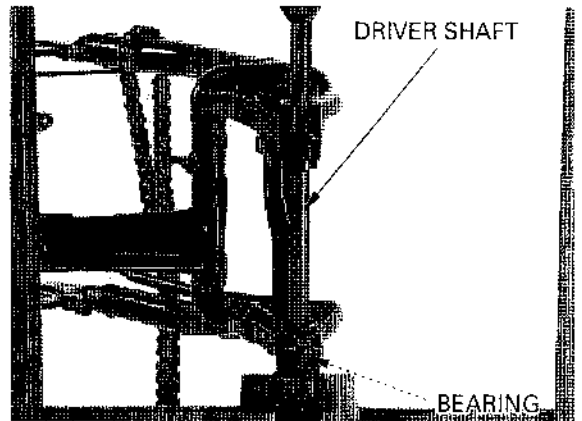

Drive the left needle bearing out of the swingarm.

**TOOL:**  
Driver shaft set 07946-KA50000

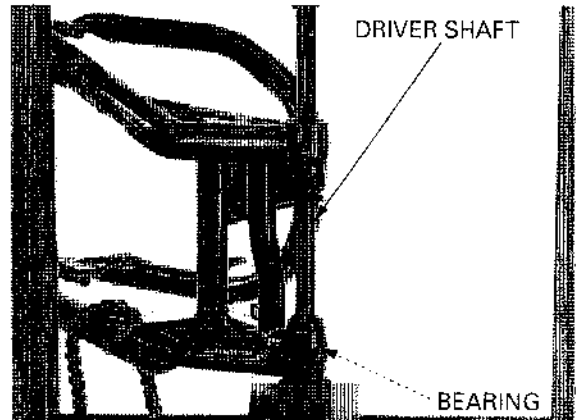

*Install the bearings with the marks facing out.*

Carefully press new bearings into the swingarm pivots.

**RIGHT SIDE BALL BEARING:**

**TOOL:**  
Driver 07749-0010000  
Attachment, 32 × 35 mm 07746-0010100  
Pilot, 15 mm 07746-0040300

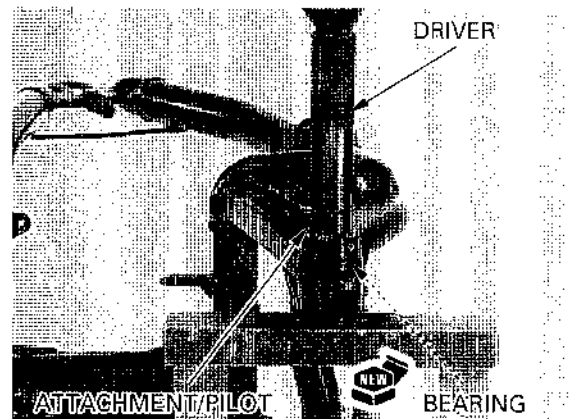

## REAR WHEEL/BRAKE/SUSPENSION

### LEFT SIDE NEEDLE BEARING:

#### TOOL:

Driver 07749-0010000  
Attachment, 28 × 30 mm 07946-1870100 **NEW**  
Pilot, 22 mm 07746-0041000

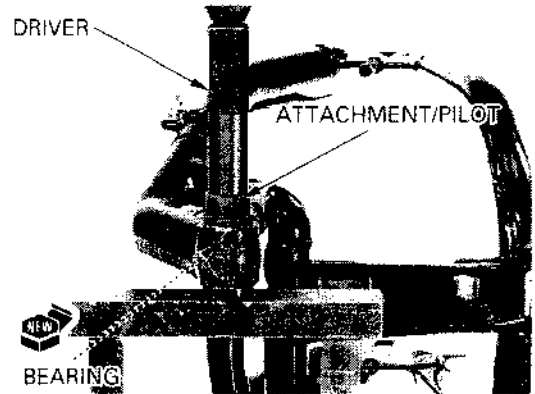

Install the new snap ring into the right pivot.

#### TOOL:

Snap ring pliers 07914-3230001

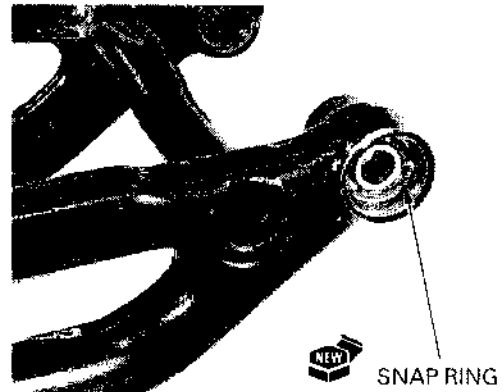

## ASSEMBLY

Apply grease to the new dust seal lips.

Apply oil to the pivot collar outer and sliding surface.

Install the dust seals and pivot collar to the swingarm left side pivot.

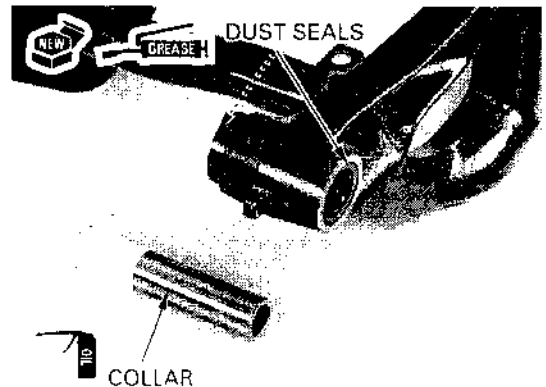

Apply grease to the new dust seal lips.

Apply oil to the pivot collars outer and sliding surface.

Install the dust seals and pivot collars to the swingarm right side pivot.

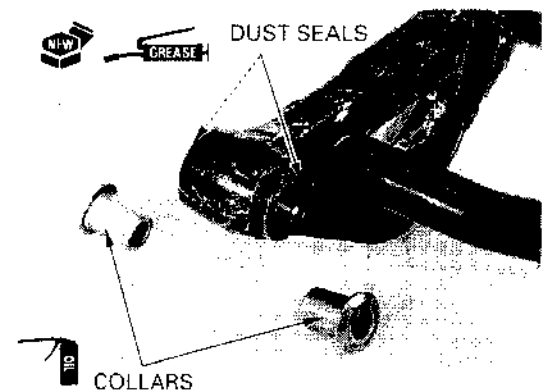

## REAR WHEEL/BRAKE/SUSPENSION

Install the stopper arm, bolt, washers and nut.  
Tighten the nut securely.  
Install the new cotter pin to secure the nut.

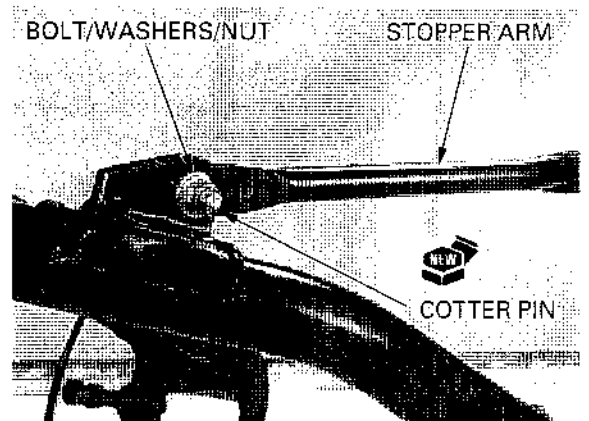

Install the drive chain cover and bolts.  
Tighten the bolts securely.

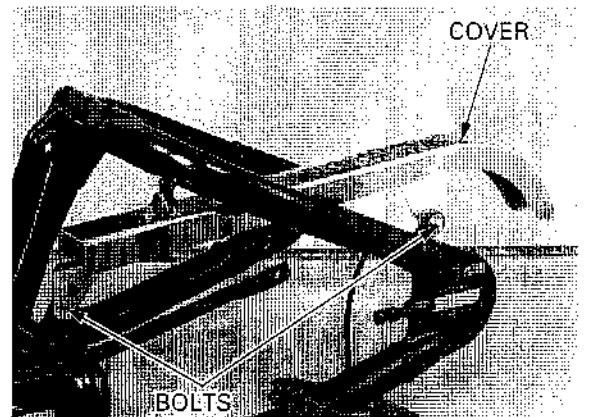

Install the drive chain slider by aligning the hole on the chain slider to the pin on the swingarm.

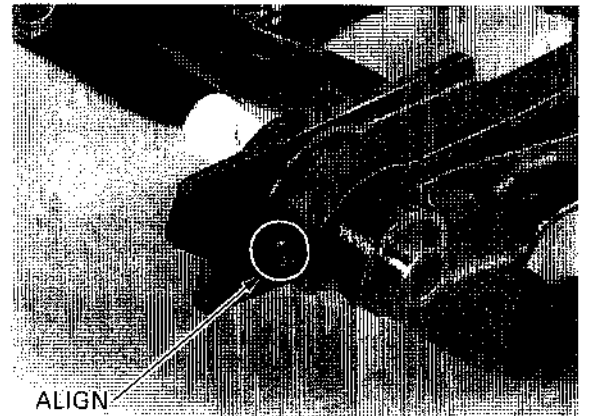

Install the collars, bolts and nuts.  
Tighten the nuts securely.

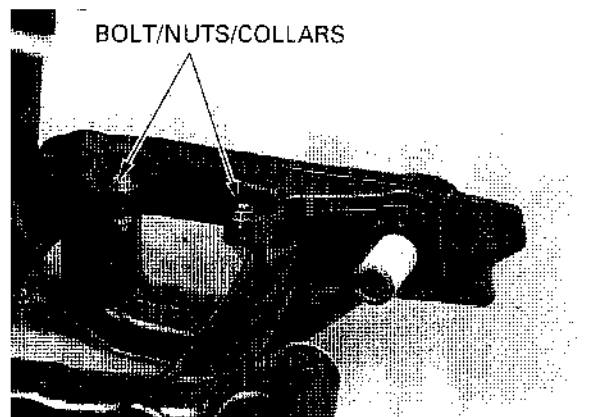

### INSTALLATION

Install the swingarm in the frame.  
Install the swingarm pivot bolt and nut.  
Tighten the nut to the specified torque.

**TORQUE:** 88 N·m (9.0 kgf·m , 65 lbf·ft)

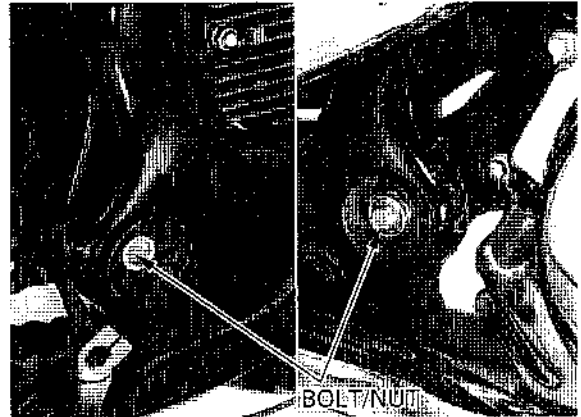

Install the swingarm pivot caps.

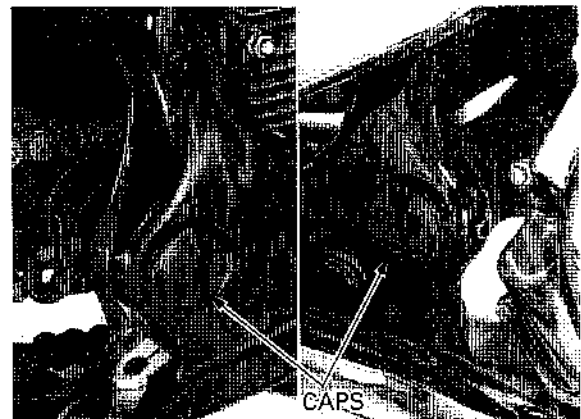

Install the shock absorber lower mounting bolt and nut.  
Tighten the nut to the specified torque.

**TORQUE:** 44 N·m (4.5 kgf·m , 33 lbf·ft)

Install the followings:

- Radiator coolant reserve tank (page 6-18).
- Evaporative emission canister (California type only).
- Gearshift arm to the gearshift spindle (page 8-16).
- Drive sprocket (page 7-14).
- Rear wheel (page 14-10).

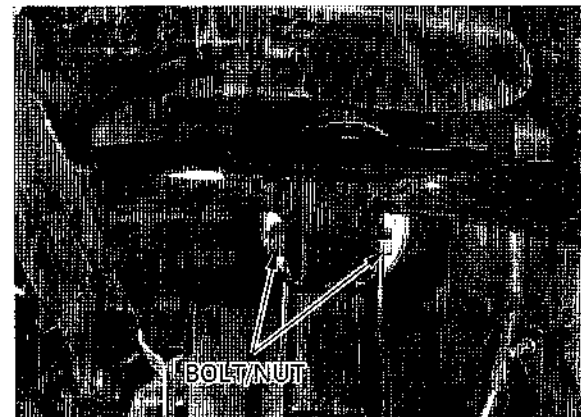

Adjust the drive chain (page 3-21).  
Adjust the rear brake pedal free play (page 3-6).

---

MEMO

---

# HYDRAULIC BRAKE

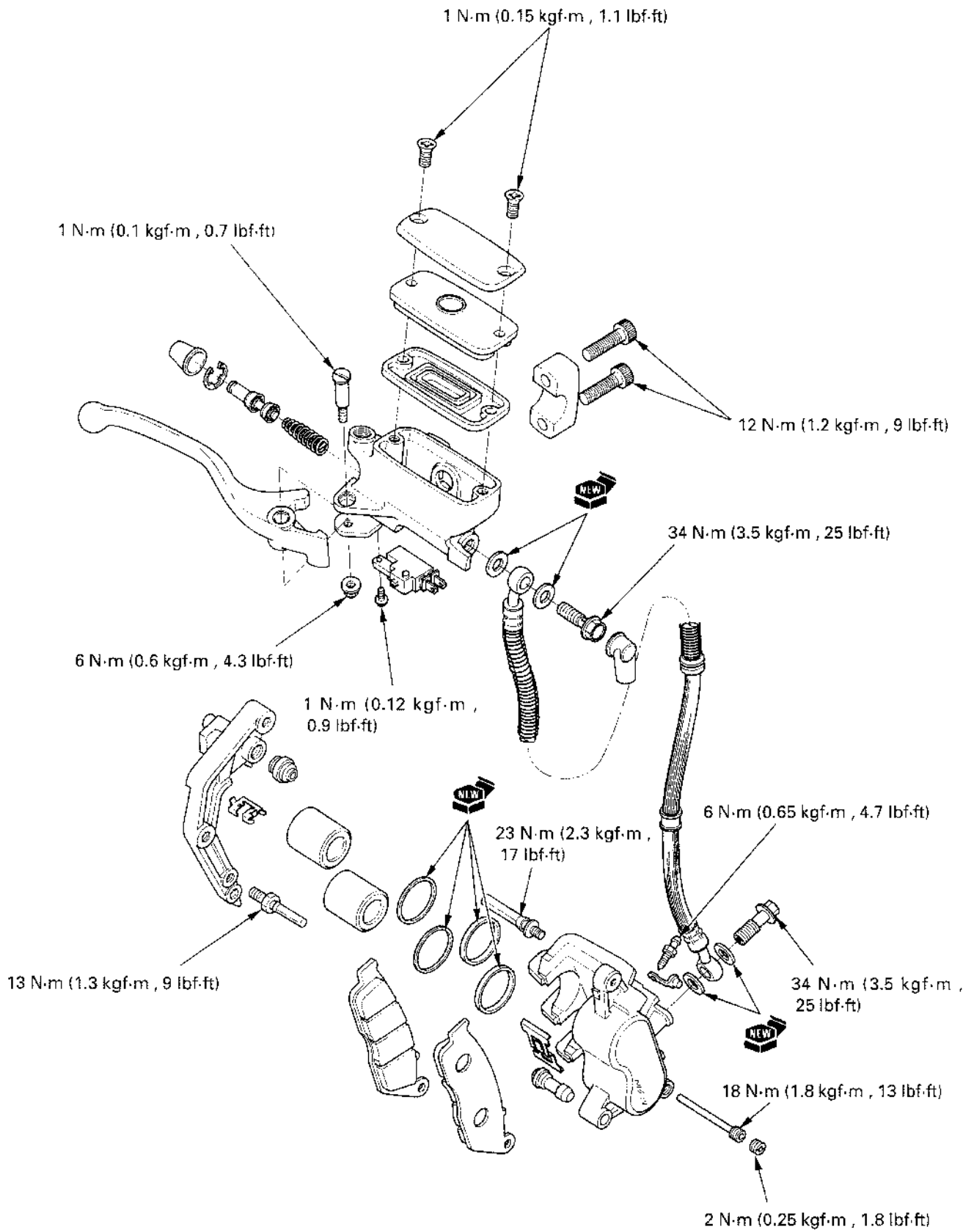

# 15. HYDRAULIC BRAKE

SERVICE INFORMATION	15-1	BRAKE PAD/DISC	15-5
TROUBLESHOOTING	15-2	MASTER CYLINDER	15-7
BRAKE FLUID REPLACEMENT/ AIR BLEEDING	15-3	BRAKE CALIPER	15-13

## SERVICE INFORMATION

### GENERAL

#### ▲WARNING

*A contaminated brake disc or pad reduces stopping power. Discard contaminated pads and clean a contaminated disc with a high quality brake degreasing agent.*

#### CAUTION:

- Support the brake caliper with a piece of wire so that it does not hang from the brake hose. Do not twist the brake hose.
- Reusing drained fluids can impair braking efficiency.
- Avoid spilling brake fluid on painted, plastic or rubber parts. Place a rag or shop towel over these parts whenever the system is serviced.

- Never allow contaminants (dirt, water, etc.) to get into an open reservoir.
- Always use fresh DOT 4 brake fluid from a sealed container when servicing the system. Do not mix different types of fluid as they may not be compatible.
- Spilled brake fluid will severely damage instrument lenses and painted surfaces. It is also harmful to some rubber parts. Be careful whenever you remove the reservoir cap: make sure the from reservoir is horizontal first.
- Do not reuse the sealing washers. Replace with new ones.
- Once the hydraulic system has been opened, or if the brake feel spongy, the system must be bled.
- Always check brake operation before riding the motorcycle.
- Always replace the brake pads is pairs to ensure even disc pressure.

### SPECIFICATIONS

Unit: mm (in)

ITEM	STANDARD	SERVICE LIMIT
Specified brake fluid	Honda DOT 4 Brake Fluid	—
Brake pad wear indicator	—	To groove
Brake disc thickness	5.0 (0.20)	4.0 (0.16)
Brake disc runout	—	0.30 (0.012)
Master cylinder I.D.	11.000 – 11.043 (0.4331 – 0.4348)	11.05 (0.435)
Master piston O.D.	10.957 – 10.984 (0.4314 – 0.4324)	10.945 (0.4309)
Caliper cylinder I.D.	27.000 – 27.050 (1.0630 – 1.0650)	27.06 (1.065)
Caliper piston O.D.	26.935 – 26.968 (1.0604 – 1.0617)	26.93 (1.060)

## HYDRAULIC BRAKE

---

### TORQUE VALUES

Brake caliper mounting bolt	30 N·m (3.1 kgf·m , 22 lbf·ft)	ALOC bolt: replace with a new one
Caliper pin bolt	23 N·m (2.3 kgf·m , 17 lbf·ft)	
Bracket pin bolt	13 N·m (1.3 kgf·m , 9 lbf·ft)	
Pad pin	18 N·m (1.8 kgf·m , 13 lbf·ft)	
Pad pin plug	2 N·m (0.25 kgf·m , 1.8 lbf·ft)	
Brake caliper bleeder	6 N·m (0.65 kgf·m , 4.7 lbf·ft)	
Brake lever pivot bolt	1 N·m (0.1 kgf·m , 0.7 lbf·ft)	
Brake lever pivot nut	6 N·m (0.6 kgf·m , 4.3 lbf·ft)	
Master cylinder holder bolt	12 N·m (1.2 kgf·m , 9 lbf·ft)	
Master cylinder cover screw	1 N·m (0.15 kgf·m , 1.1 lbf·ft)	
Front brake light switch screw	1 N·m (0.12 kgf·m , 0.9 lbf·ft)	
Brake hose oil bolt	34 N·m (3.5 kgf·m , 25 lbf·ft)	

### TOOLS

Snap ring pliers 07914 – 3230001 or equivalent commercially available in U.S.A.

## TROUBLESHOOTING

#### Brake lever soft or spongy

- Air in the hydraulic system
- Leaking hydraulic system
- Contaminated brake disc/pad
- Worn caliper piston seal
- Worn master cylinder piston cup
- Worn brake pad/disc
- Contaminated caliper
- Caliper not sliding properly
- Low fluid level
- Clogged fluid passage
- Warped/deformed brake disc
- Sticking/worn caliper piston
- Sticking/worn master cylinder piston
- Contaminated master cylinder
- Bent brake lever

#### Brake lever hard

- Sticking/worn caliper piston
- Caliper not sliding properly
- Clogged/restricted fluid passage
- Worn caliper piston seal
- Sticking/worn master cylinder piston
- Bent brake lever

#### Brake grab or pull to one side

- Contaminated brake pad/disc
- Misaligned wheel
- Clogged/restricted brake hose joint
- Warped/deformed brake disc
- Caliper not sliding properly

#### Brakes drag

- Contaminated brake disc/pad
- Warped/deformed brake disc
- Caliper not sliding properly
- Misaligned wheel



## BRAKE FLUID REPLACEMENT/AIR BLEEDING

### ▲WARNING

*A contaminated brake disc or pad reduces stopping power. Discard contaminated pads and clean contaminated disc with a high quality brake degreasing agent.*

### CAUTION:

- Do not allow foreign material to enter the system when filling the reservoir.
- Avoid spilling fluid on painted, plastic or rubber parts. Place a rag over these parts whenever the system is serviced.
- Use only DOT 4 brake fluid from a sealed container.
- Do not mix different types of fluid. They are not compatible.

### BRAKE FLUID DRAINING

For the front brake, turn the handlebar to the left until the reservoir is level. Remove the screws, reservoir cover, set plate and diaphragm.

Connect the bleed tube to the bleed valve.

Loosen the bleed valve and pump the brake lever until no more fluid flows out of the bleed valve.

### BRAKE FLUID FILLING/BLEEDING

Close the bleed valve.

Fill the reservoir with DOT 4 brake fluid from a sealed container.

Connect a commercially available brake bleeder to the bleed valve.

Pump the brake bleeder and loosen the bleed valve. Add brake fluid when the fluid level in the reservoir is low.

### NOTE:

- Check the fluid level often while bleeding the brake to prevent air from being pumped into the system.
- When using a brake bleeding tool, follow the manufacturer's operating instructions.

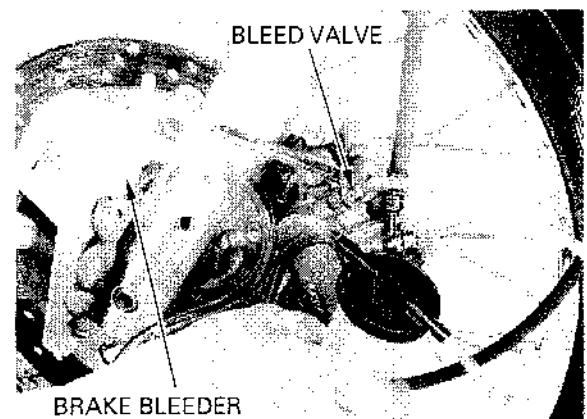
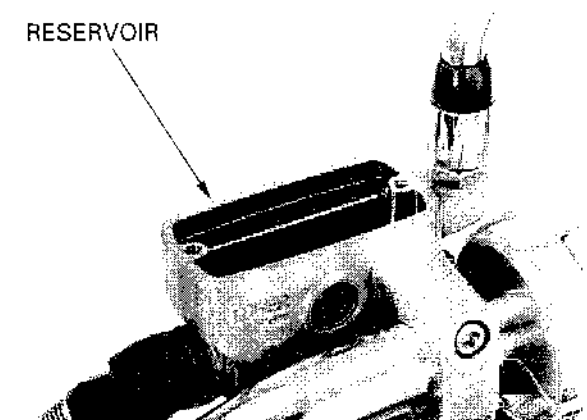
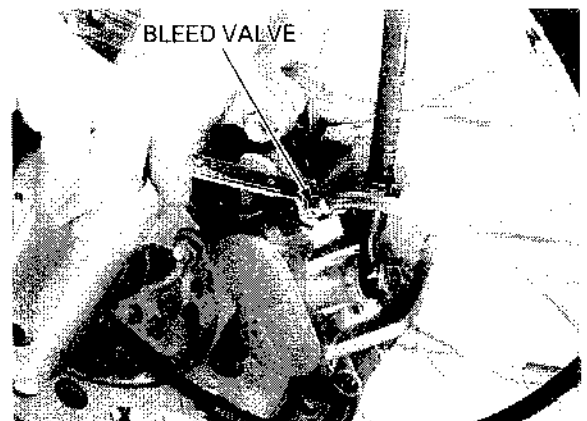
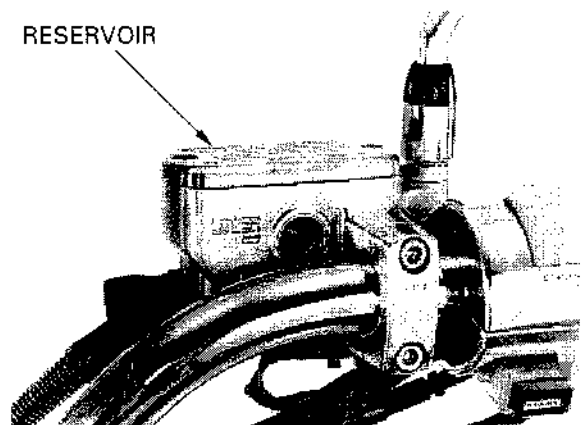

## HYDRAULIC BRAKE

---

Repeat the above procedures until air bubbles do not appear in the plastic hose.

**NOTE:**

---

If air is entering the bleeder from around the bleed valve threads, seal the threads with teflon tape.

---

Close the bleed valve and operate the brake lever. If it still feels spongy, bleed the system again.

If a brake bleeder is not available, use the following procedure:

Pump up the system pressure with the brake lever until lever resistance is felt.

Connect a bleed hose to the bleed valve and bleed the system as follows:

1. Squeeze the brake lever. Open the bleed valve 1/2 turn and close it.

**NOTE:**

---

Do not release the brake lever until the bleed valve has been closed.

---

2. Release the brake lever slowly and wait several seconds after it stops moving.

Repeat steps 1 and 2 until air bubbles do not appear in the bleed valve.

Tighten the bleed valve.

**TORQUE:** 5 N·m (0.55 kgf·m , 4.0 lbf·ft)

Fill the reservoir to the upper level mark with DOT 4 brake fluid from a sealed container.

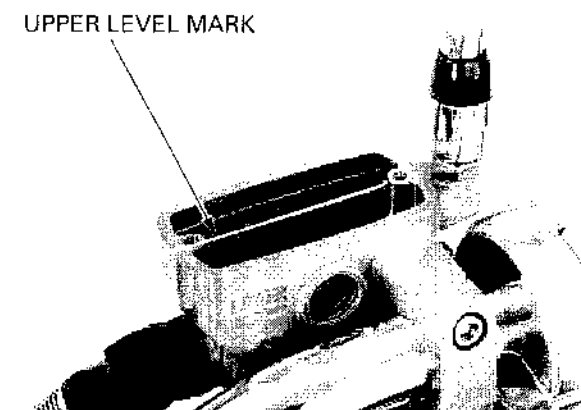
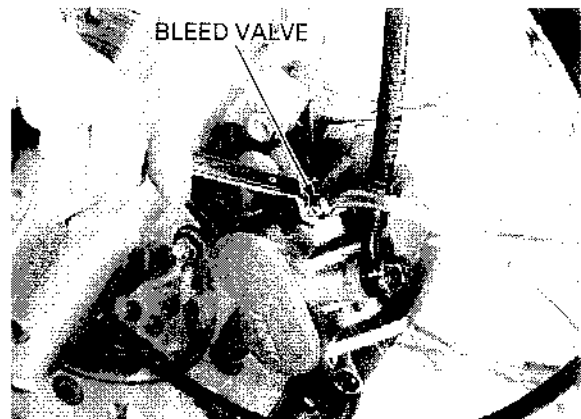
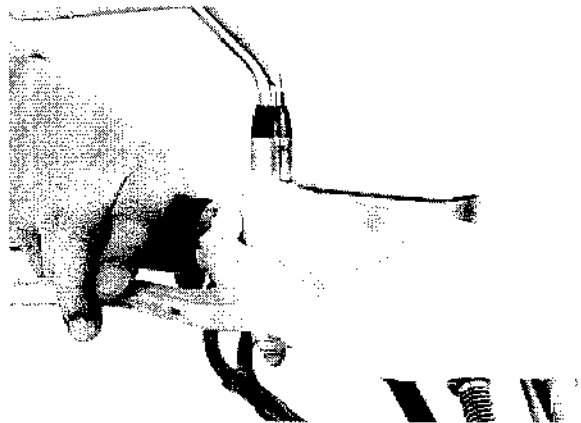

Install the diaphragm, set plate and reservoir cover. Tighten the screws to the specified torque.

**TORQUE:** 1 N·m (0.15 kgf·m , 1.1 lbf·ft)

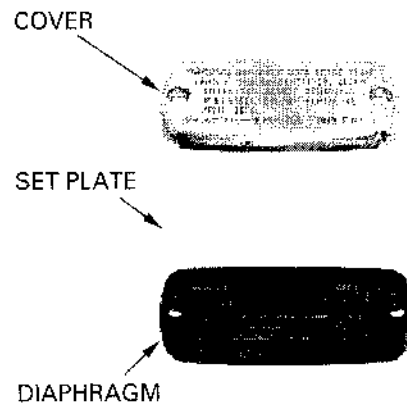

## BRAKE PAD/DISC

### ▲WARNING

*A contaminated brake disc or pad reduces stopping power. Discard contaminated pads and clean contaminated disc with a high quality brake degreasing agent.*

### BRAKE PAD REPLACEMENT

*Always replace the brake pads in pairs to ensure even disc pressure.*

Push the caliper pistons all the way in by pushing the caliper body inward to allow installation of new brake pads.

#### NOTE:

Check the brake fluid level in the brake master cylinder reservoir as this operation causes the level to rise.

Remove the pad pin plug and loosen the pad pin.

Remove the pad pin and the brake pads.

Install the new pads so that their ends rest on the pad retainer on the bracket properly.

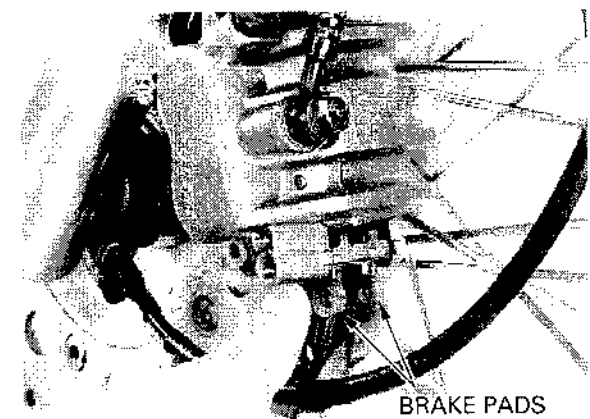
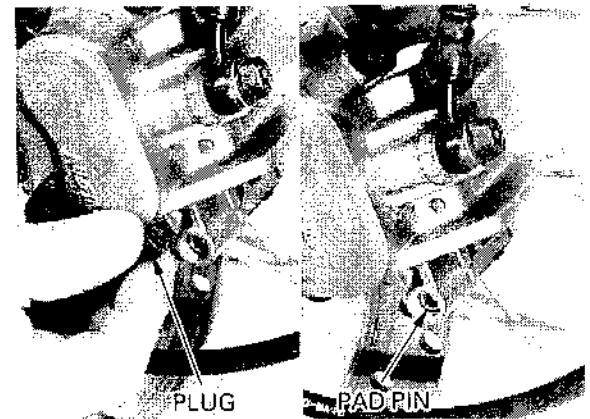
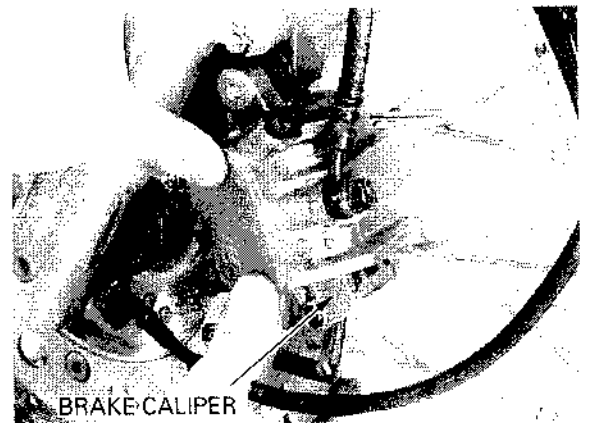

## HYDRAULIC BRAKE

Install the pad pin by pushing the pads against the pad spring to align the pad pin holes in the pads and caliper.

Tighten the pad pin to the specified torque.

**TORQUE:** 18 N·m (1.8 kgf·m , 13 lbf·ft)

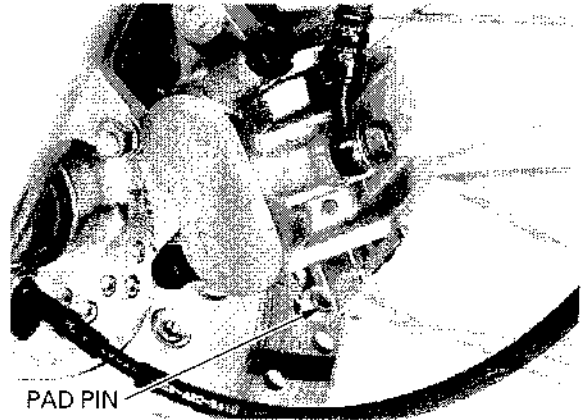

Install and tighten the pad pin plug to the specified torque.

**TORQUE:** 2 N·m (0.25 kgf·m , 1.8 lbf·ft)

### **▲WARNING**

*After replacement, operate the brake lever to seat the caliper pistons against the pads.*

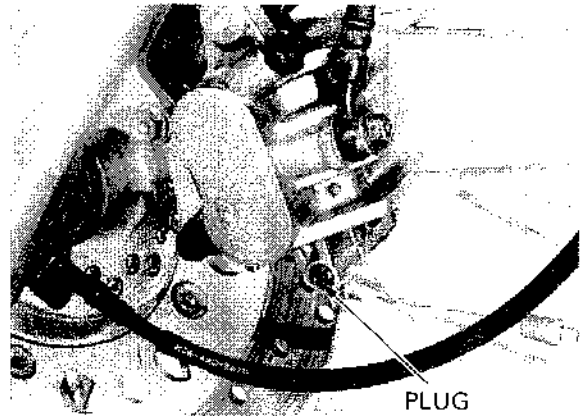

## BRAKE DISC INSPECTION

Visually inspect the disc for damage or cracks.

Measure the brake disc thickness at several points.

**SERVICE LIMIT:** 4.0 mm (0.16 in)

Replace the brake disc if the smallest measurement is less than the service limit.

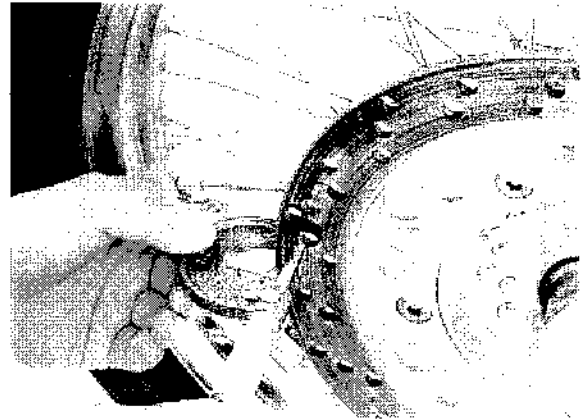

Check the brake disc for warpage.

**SERVICE LIMIT:** 0.30 mm (0.012 in)

Check the wheel bearings for excessive play, if the warpage exceeds the service limit.  
Replace the brake disc if the wheel bearings are normal.



## MASTER CYLINDER

### CAUTION:

- *Avoid spilling brake fluid on painted, plastic or rubber parts. Place a rag or shop towel over these parts whenever the system is serviced.*
- *When removing the oil hose, cover the end of the hose to prevent contamination.*

### REMOVAL

Drain the brake fluid (page 15-3).  
Remove the right rearview mirror.

Disconnect the brake hose by removing the oil bolt and sealing washers.

Remove the master cylinder holder bolts, holder and master cylinder.

Disconnect the brake light switch connectors.

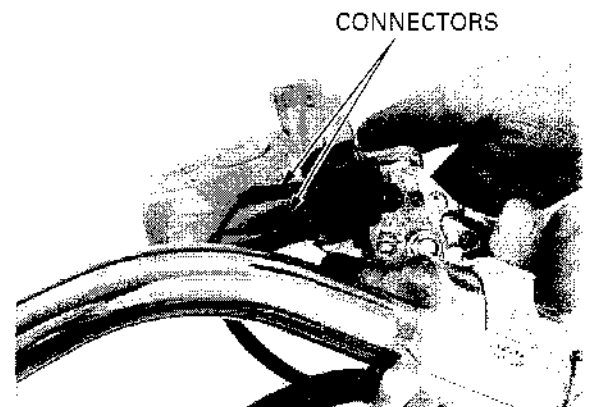
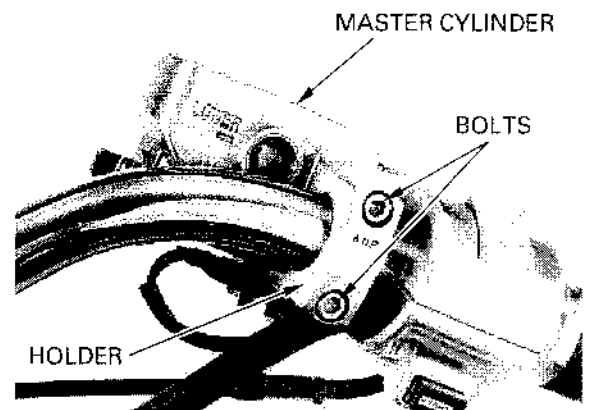
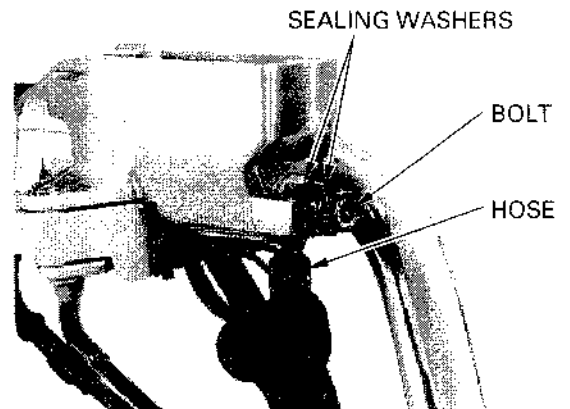
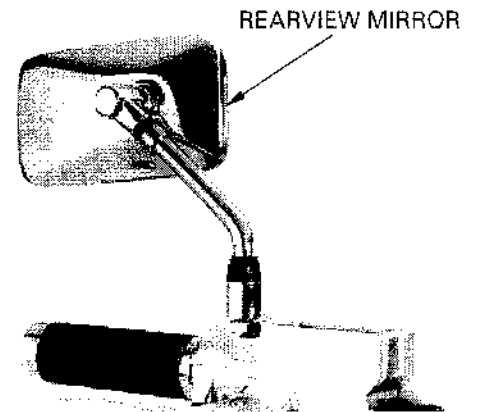

## HYDRAULIC BRAKE

---

### DISASSEMBLY

Remove the brake lever pivot nut, bolt and brake lever.

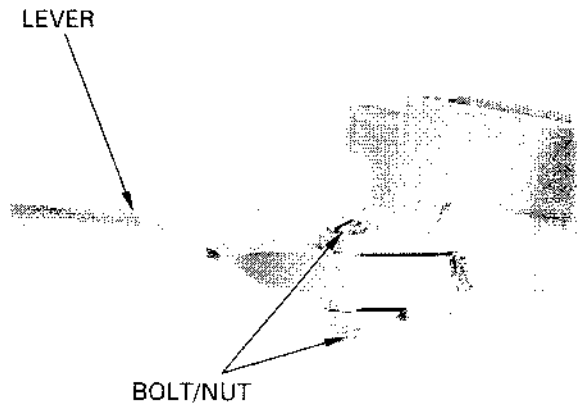

Remove the screw and brake light switch.

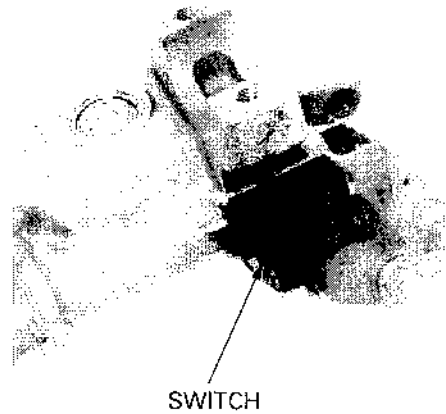

Remove the boot from the master cylinder and master piston.

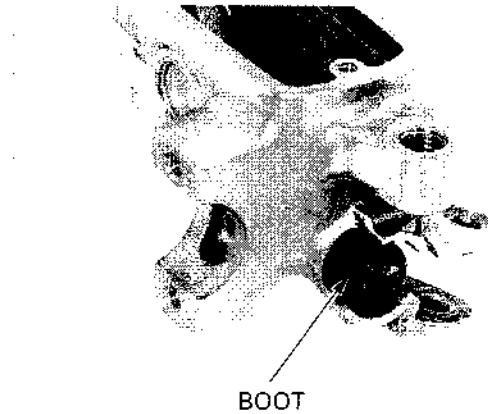

Remove the snap ring.

**TOOL:**  
Snap ring pliers

07914--3230001 or  
equivalent  
commercially available  
in U.S.A.

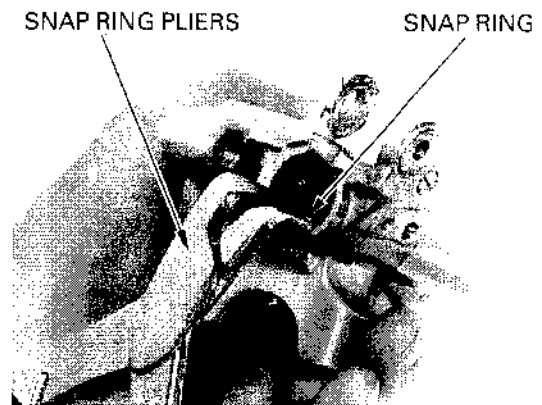

Remove the master piston and spring from the master cylinder.

Clean the master cylinder, reservoir and master piston with clean brake fluid.

**NOTE:**

- Replace the master piston, spring, cups and snap ring as a set whenever they are disassembled.
- Be sure that each part is free from the dust or dirt before reassembly.
- Never allow contaminants (dirt, water, etc.) to get into an open reservoir.

## INSPECTION

Check the piston cups for wear, deterioration or damage.

Check the master cylinder and piston for scoring, scratches or damage.

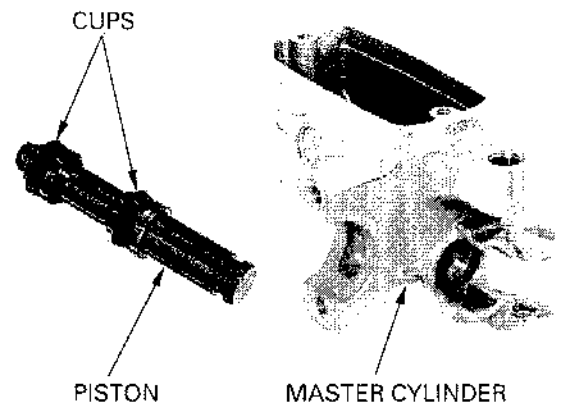
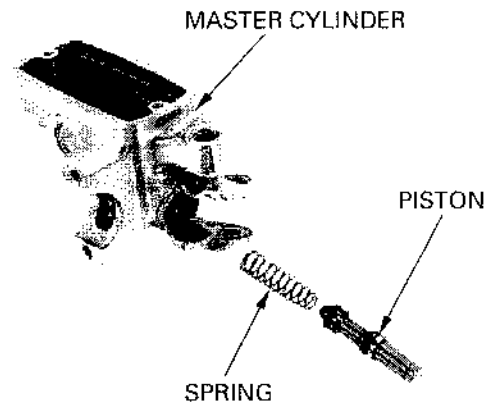

Measure the master cylinder I.D.

**SERVICE LIMIT:** 11.05 mm (0.435 in)

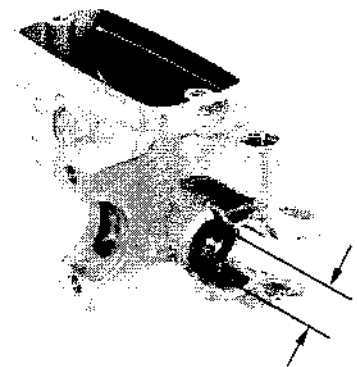

Measure the master piston O.D.

**SERVICE LIMIT:** 10.945 mm (0.4309 in)

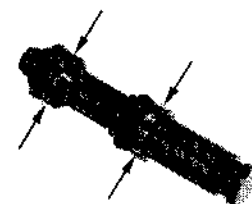

# HYDRAULIC BRAKE

## ASSEMBLY

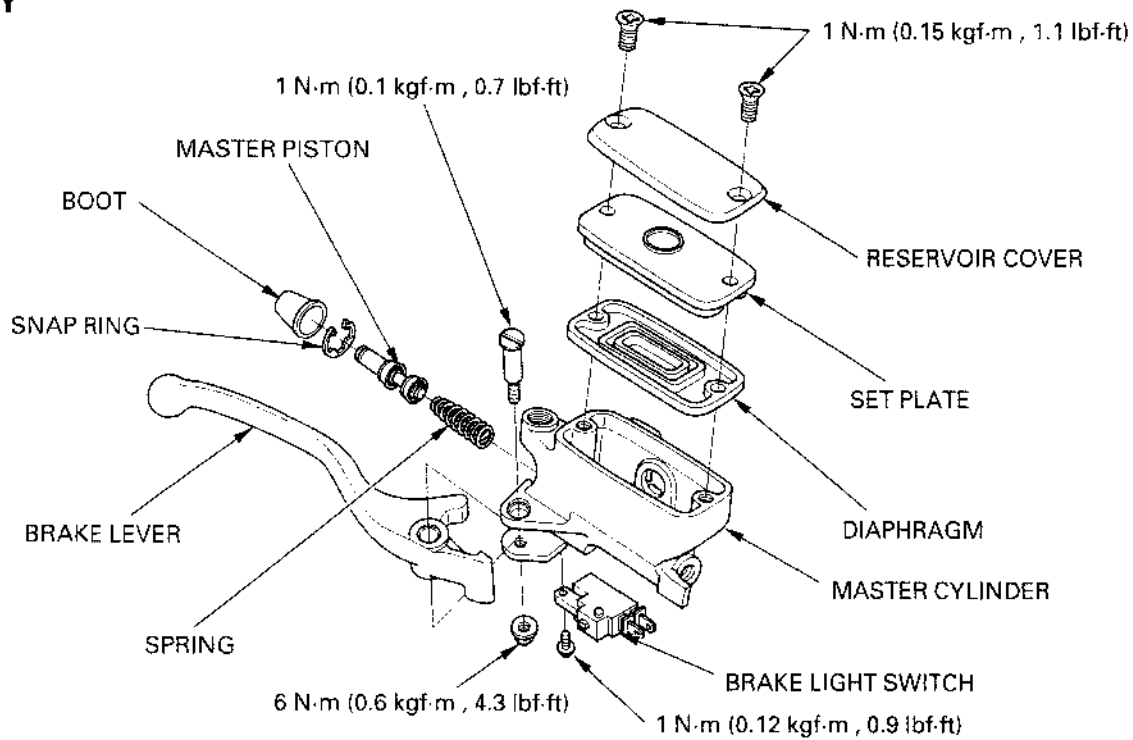

### NOTE:

- Replace the master piston, spring, cups and snap ring as a set.
- Replace the boot if it shows wear, deterioration or damage.
- Apply silicone grease to the boot inner surface.
- Be sure that each part is free from the dust or dirt before reassembly.

Coat the master piston, spring, and piston cups with clean DOT 4 brake fluid.  
Install the spring onto the master piston end.  
Install the master piston/spring and washer into the master cylinder.

### CAUTION:

***Do not allow the piston cup lips to turn inside out.***

Install the snap ring into the groove in the master cylinder.

### TOOL:

**Snap ring pliers**

07914-3230001 or equivalent commercially available in U.S.A.

### CAUTION:

***Be certain the snap ring is firmly seated in the groove.***

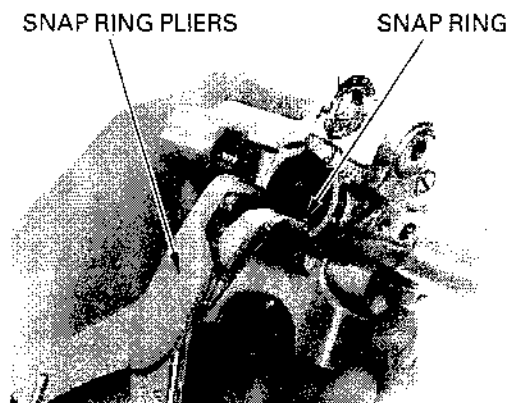
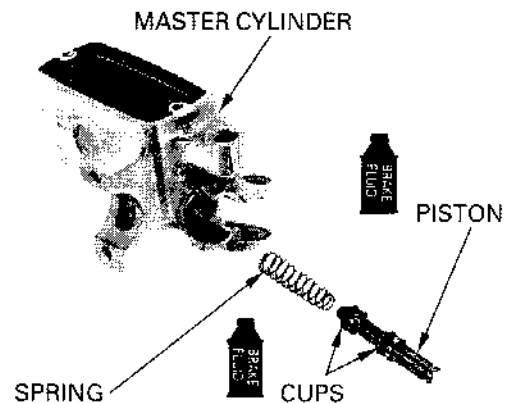



Install the boot into the master cylinder and the groove in the master piston.  
Apply silicone grease to the brake lever contacting surface of the master cylinder.

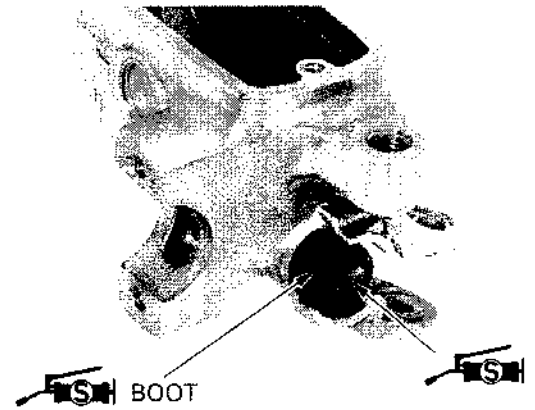

Install the brake light switch to the master cylinder by aligning the brake light switch boss and master cylinder hole.

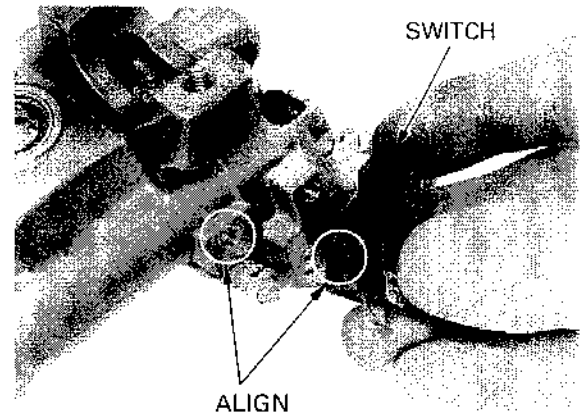

Install and tighten the screw to the specified torque.

**TORQUE:** 1 N·m (0.12 kgf·m , 0.9 lbf·ft)

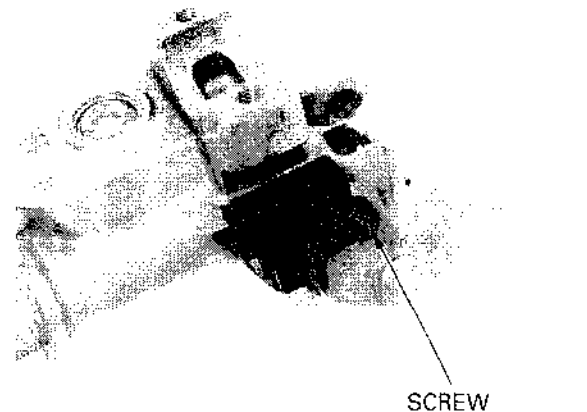

Apply grease to the brake lever pivot bolt.  
Install the brake lever to the master cylinder.  
Install and tighten the brake lever pivot bolt and nut.

**TORQUE: Bolt:** 1 N·m (0.1 kgf·m , 0.7 lbf·ft)  
**Nut:** 6 N·m (0.6 kgf·m , 4.3 lbf·ft)

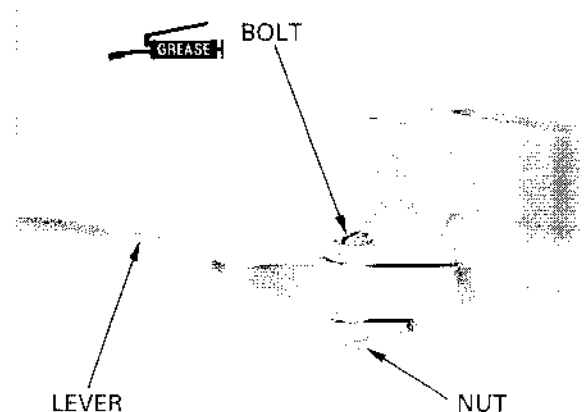

# HYDRAULIC BRAKE

## INSTALLATION

Connect the brake light switch connectors.

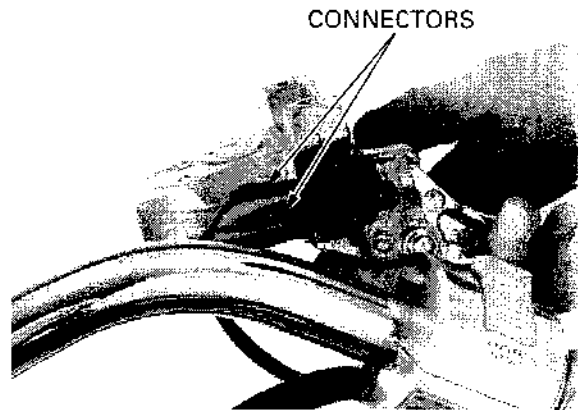

Install the master cylinder and the master cylinder holder with the "UP" mark facing up.

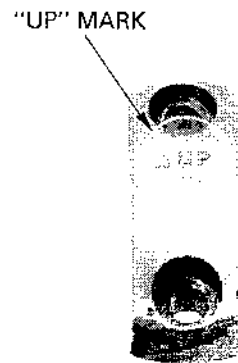

Align the end of the master cylinder with the punch mark on the handlebar. Install the front master cylinder bolts and tighten the upper bolt first, then tighten the lower bolt to the specified torque.

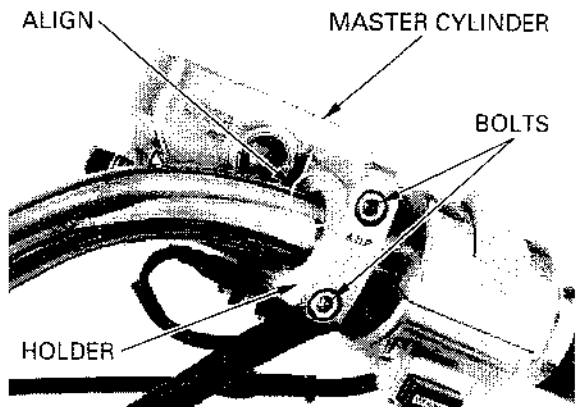

**TORQUE:** 12 N·m (1.2 kgf·m , 9 lbf·ft)

*Be careful not to twist the brake hose.* Connect the brake hose eyelet with the oil bolt and new sealing washers.

Tighten the brake hose oil bolt to the specified torque.

**TORQUE:** 34 N·m (3.5 kgf·m , 25 lbf·ft)

**NOTE:**

While tightening the brake hose oil bolt, align the brake hose end with the stopper.

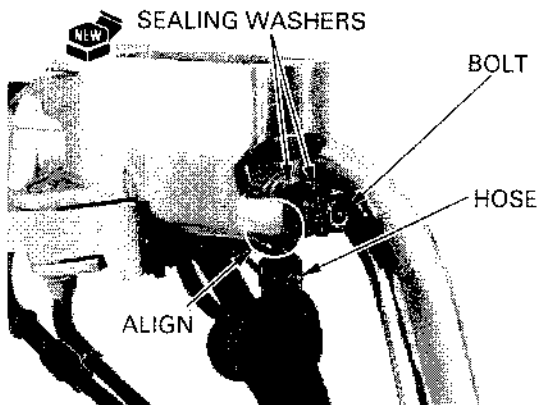

Install the right rearview mirror.  
Refill the brake fluid (page 15-3).

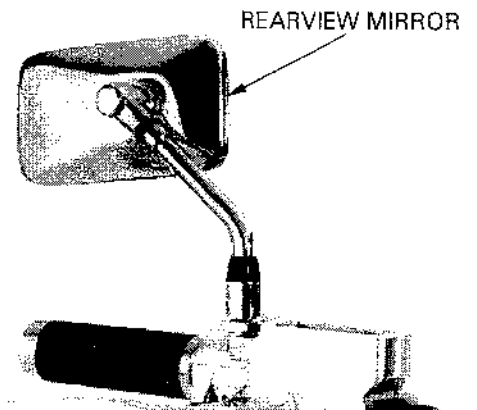

## BRAKE CALIPER

### CAUTION:

- *Avoid spilling brake fluid on painted, plastic or rubber parts. Place a rag or shop towel over these parts whenever the system is serviced.*
- *When removing the oil hose bolt, cover the end of the hose to prevent contamination.*

### REMOVAL

Drain the brake fluid (page 15-3).

Remove the brake hose oil bolt and sealing washers, and disconnect the brake hose from the front brake caliper.

Remove the front brake caliper mounting bolts and front brake caliper.

Remove the brake pad (page 15-5).

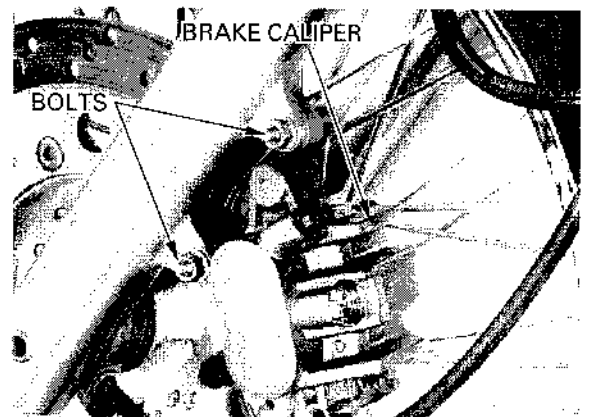
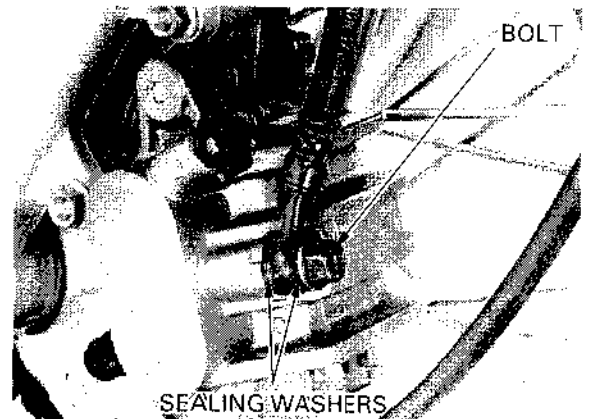

### DISASSEMBLY

#### NOTE:

Do not remove the caliper and bracket pins unless replacement is necessary.

Remove the caliper bracket from the caliper body.

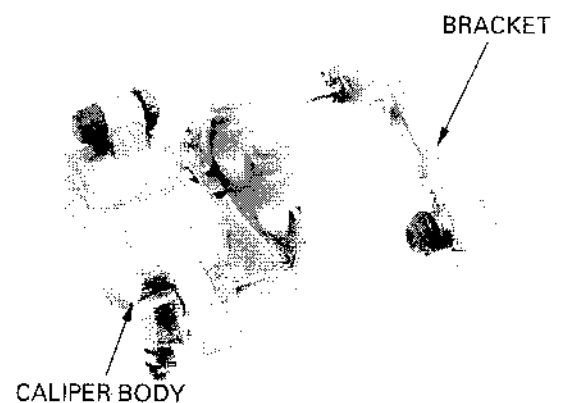

## HYDRAULIC BRAKE

Remove the caliper pin boot and pad retainer from the caliper bracket.

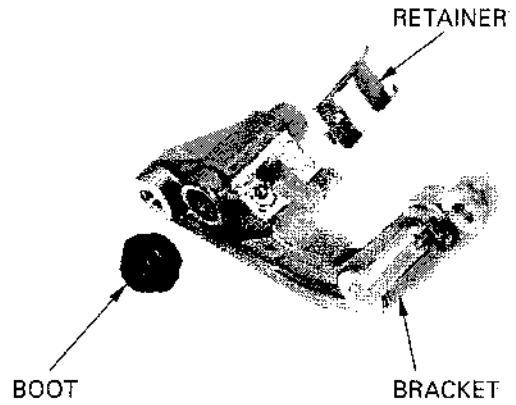

Remove the pad spring and bracket pin boot from the caliper body.

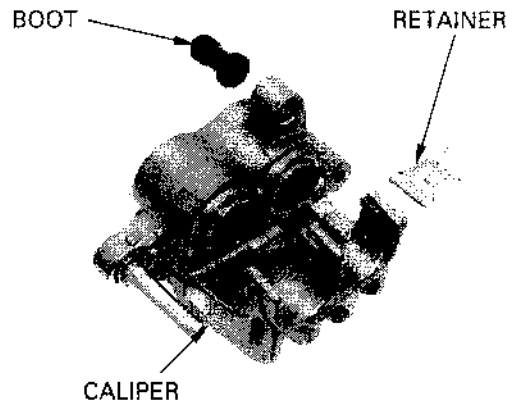

Place a shop towel over the pistons. Position the caliper body with the pistons down and apply small squirts of air pressure to the fluid inlet to remove the pistons.

**▲WARNING**

*Do not use high pressure air or bring the nozzle too close to the inlet.*

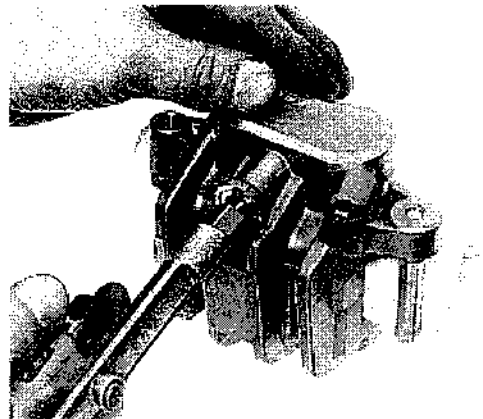

Push the dust seals and piston seals in and lift them out.

**CAUTION:**

*Be careful not to damage the piston sliding surface.*

Clean the seal grooves, caliper pistons and caliper piston sliding surfaces with clean brake fluid.

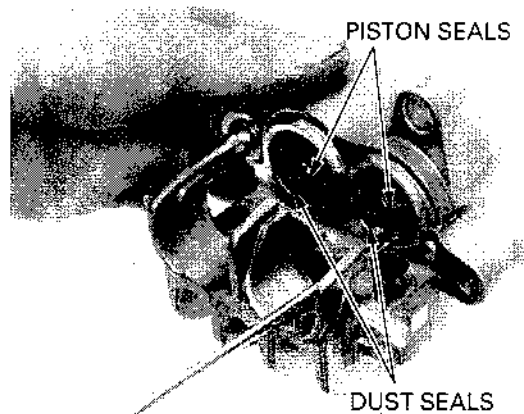

**INSPECTION**

Check the caliper cylinder and pistons for scoring, scratches or damage.

Measure the caliper cylinder I.D.

**SERVICE LIMIT:** 27.06 mm (1.065 in)

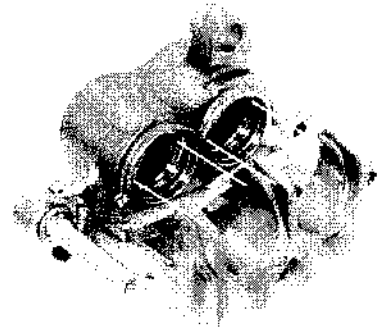

Measure the caliper piston O.D.

**SERVICE LIMIT:** 26.93 mm (1.060 in)

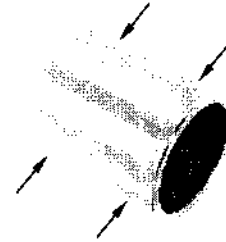

**ASSEMBLY**

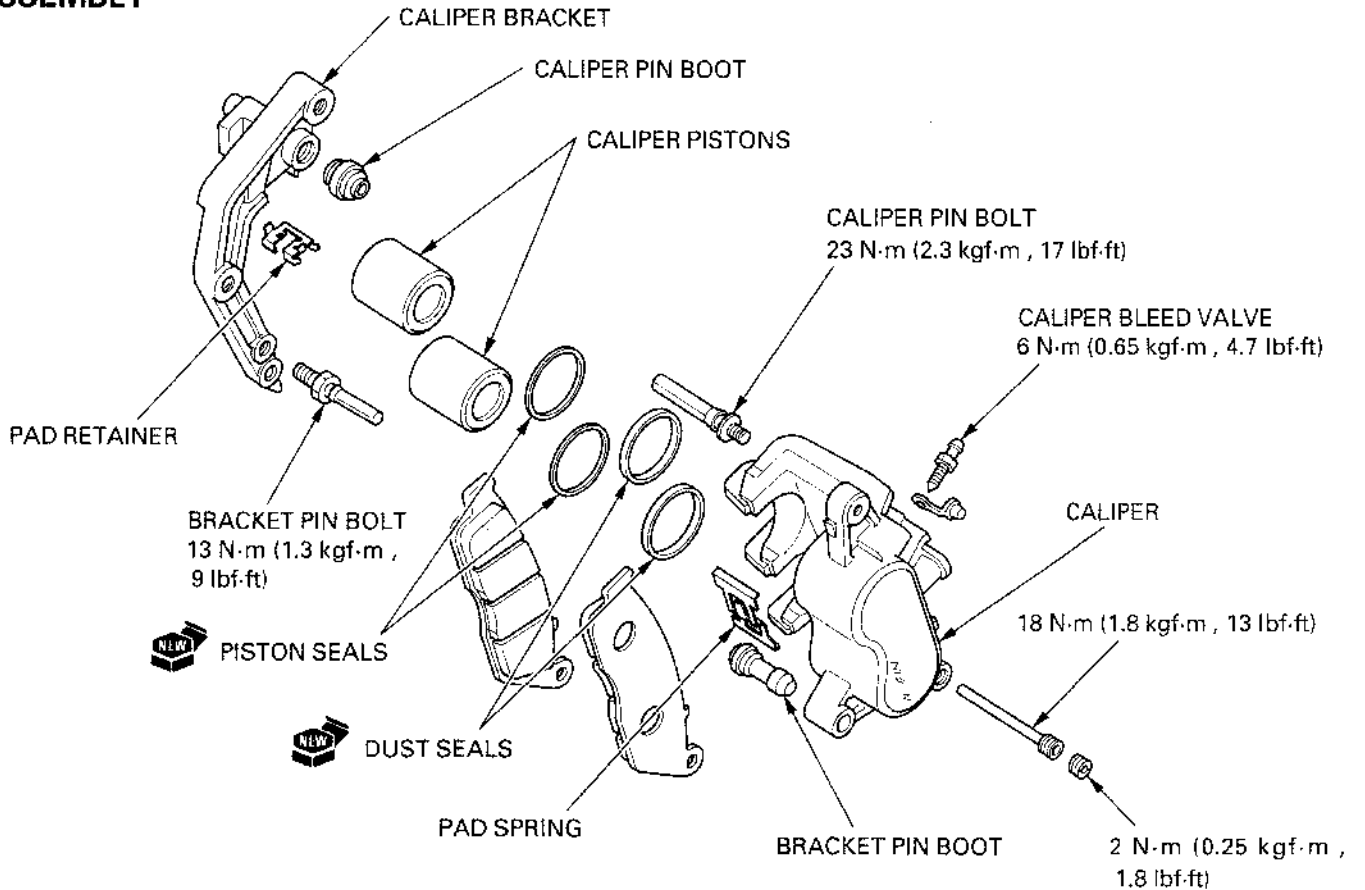

## HYDRAULIC BRAKE

### NOTE:

- Replace the dust seals and piston seals with a new ones.
- Replace the caliper and bracket pin boots if it is wear, deterioration or damage.
- Apply silicone grease to the boot inner surface.
- Be sure that each part is free from the dust or dirt before reassembly.

Coat new piston seals with clean brake fluid and install them in the seal grooves in the caliper.

Coat new dust seals with silicone grease and install them in the seal grooves in the caliper.

Coat the caliper piston with clean brake fluid and install it into the caliper cylinder with the opening toward the pads.

Install the pad spring to the caliper body.

Replace the bracket pin boot with a new ones if it is wear, deterioration or damage.

Install the bracket pin boot to the caliper body.

Replace the caliper pin boot with a new ones if it is wear, deterioration or damage.

Install the caliper pin boot and pad retainer to the caliper bracket.

Apply silicone grease to the caliper and bracket pins.

Install the caliper bracket over the caliper.

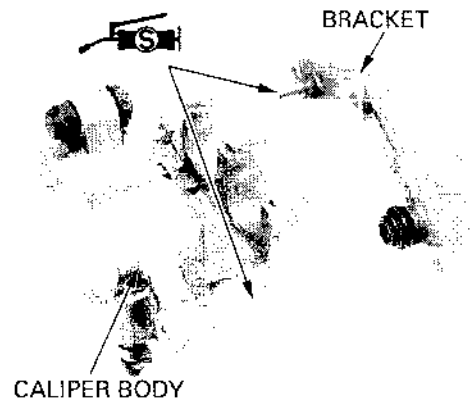
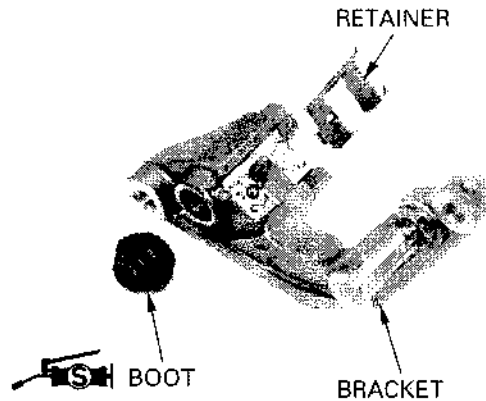
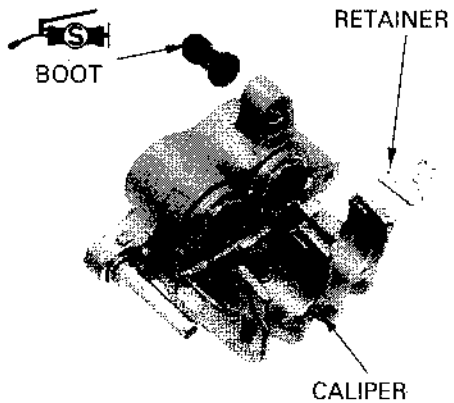
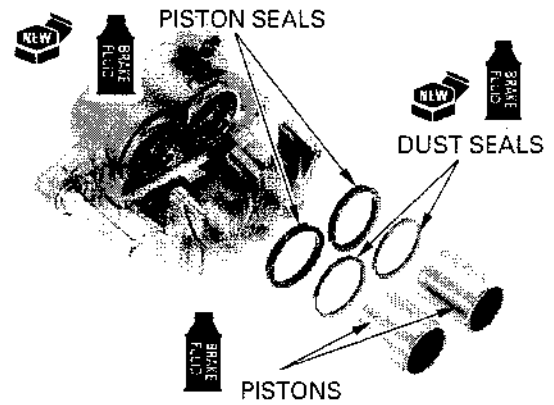

## INSTALLATION

Install the front brake caliper to the front fork.  
Install and tighten the new front caliper mounting bolts to the specified torque.

**TORQUE:** 30 N·m (3.1 kgf·m , 22 lbf·ft)

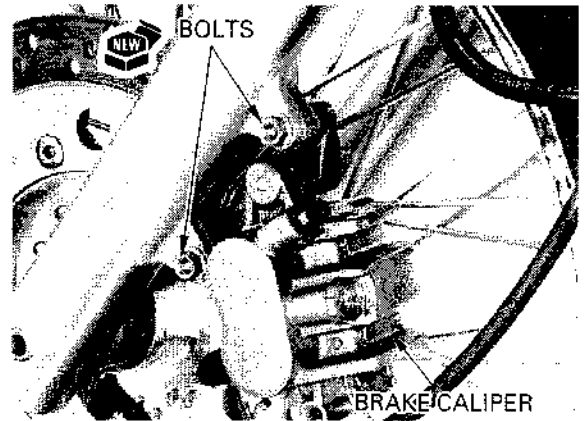

*Be careful not to twist the brake hose.*

Connect the brake hose to the brake caliper with new sealing washers.

Install and tighten the brake hose oil bolt to the specified torque.

**TORQUE:** 34 N·m (3.5 kgf·m , 25 lbf·ft)

**NOTE:**

While tightening the brake hose oil bolt, align the brake hose end with the stopper.

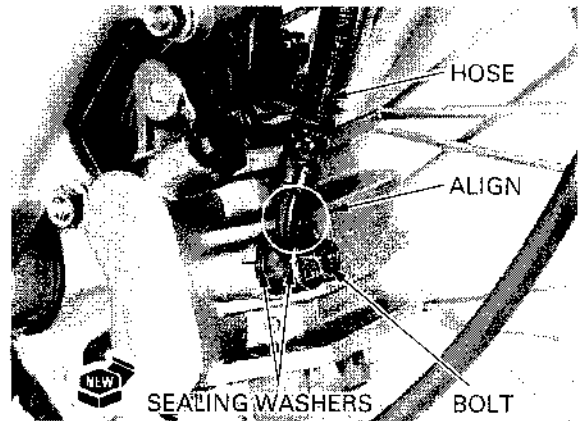

Refill the brake fluid (page 15-3).  
Install the brake pads (page 15-5).

# BATTERY/CHARGING SYSTEM

'97 - '98:

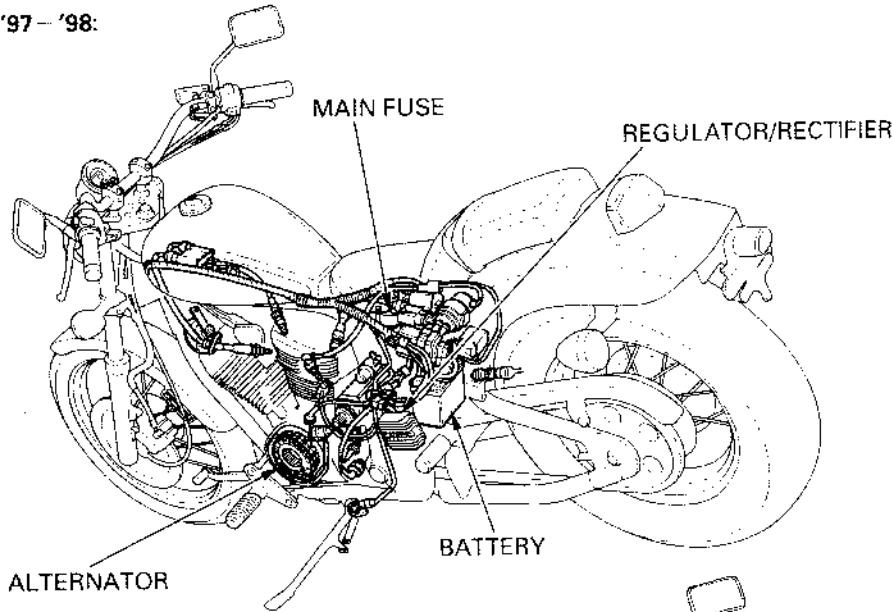

After '98:

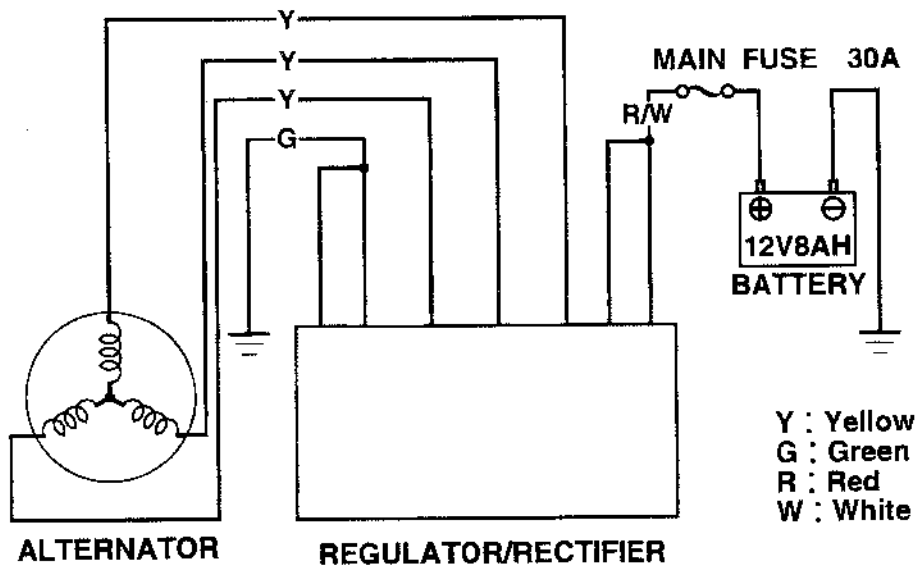
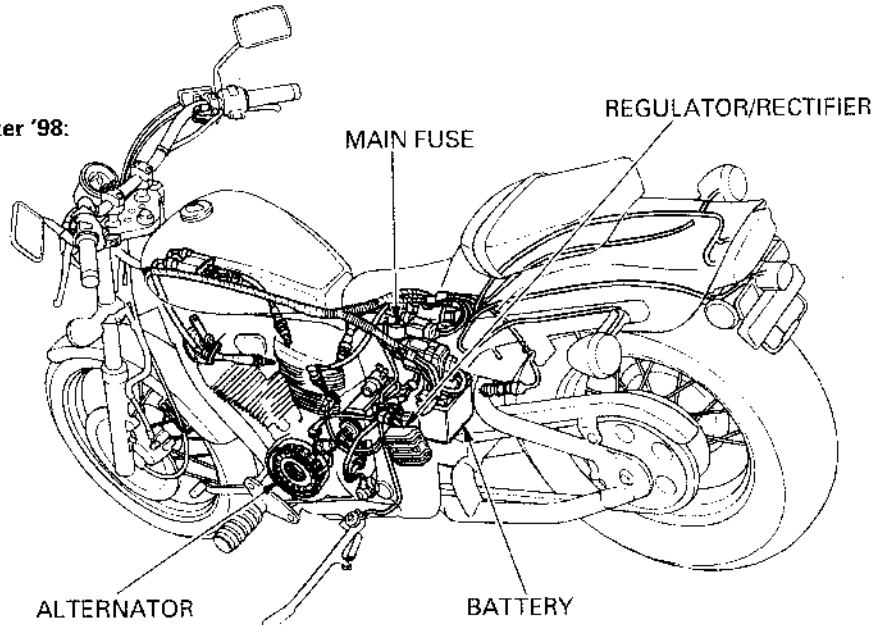



# 16. BATTERY/CHARGING SYSTEM

SYSTEM DIAGRAM	16-0	BATTERY	16-5
SERVICE INFORMATION	16-1	CHARGING SYSTEM INSPECTION	16-7
TROUBLESHOOTING	16-3	REGULATOR/RECTIFIER	16-9

## SERVICE INFORMATION

### GENERAL

#### ▲WARNING

- *The battery gives off explosive gases; keep sparks, flames and cigarettes away. Provide adequate ventilation when charging.*
- *The battery contains sulfuric acid (electrolyte). Contact with skin or eyes may cause severe burns. Wear protective clothing and a face shield.*
  - *If electrolyte gets on your skin, flush with water.*
  - *If electrolyte gets in your eyes, flush with water for at least 15 minutes and call a physician immediately.*
- *Electrolyte is poisonous.*
  - *If swallowed, drink large quantities of water or milk and follow with milk of magnesia or vegetable oil and call a physician. KEEP OUT OF REACH OF CHILDREN.*

- Always turn off the ignition switch before disconnecting any electrical components.

#### CAUTION:

*Some electrical components may be damaged if terminals or connectors are connected or disconnect while the ignition switch is ON and a current is present.*

- For extended storage, remove the battery, give it a full charge and store it in a cool, dry space. For maximum service life, charge the stored battery every two weeks.
- For battery remaining in a stored motorcycle, disconnect the negative battery cable from the battery terminal.
- The battery can be damaged if overcharged or undercharged, or if left to discharge for long periods. These same conditions contribute to shortening the life-span of the battery. Even under normal use, the performance of the battery deteriorates after 2-3 years.
- Battery voltage may recover after battery charging, but under a heavy load, battery voltage will drop quickly and eventually the battery will be completely discharged. For this reason, the charging system is often suspected to be the problem. Battery overcharge often results in problems in the battery itself, which may appear to be an overcharge symptom. If one of the battery cells is shorted and the battery voltage does not increase, the regulator/rectifier supplies excess voltage to the battery. Under these conditions, the electrolyte level drops quickly.
- Before troubleshooting the charging system, check for proper use and maintenance of the battery. Check if the battery is frequently under a heavy load, such as having the headlight and taillight ON for long periods of time without riding the motorcycle.
- The battery will self-discharge when the motorcycle is not use. For this reason, charge the battery every two weeks to prevent sulfation from forming.
- Filling a new battery with electrolyte will produce some voltage, but in order to achieve maximum performance, always charge the battery. Also, the battery life is lengthened when it is initial-charged.
- When checking the charge system, always follow the steps in the troubleshooting flow chart (page 16-3).
- Alternator servicing may be done with the engine in the frame.

## BATTERY/CHARGING SYSTEM

### SPECIFICATIONS

ITEM		SPECIFICATIONS	
Battery	Capacity	12V 8AH	
	Current leakage	1.3 mA max.	
	Voltage (20°C/68°F)	Fully charged	13.0 – 13.2 V
		Needs charging	Below 12.3 V
	Charging current	Normal	0.8 A/10 h
Quick		4.0 A/1 h max	
Alternator	Capacity	345 W/5,000 rpm	
	Charging coil resistance (20°C/68°F)	0.1 – 1.0 Ω	
Regulator/rectifier regulated voltage		14 – 15 V/4,000 rpm	

# TROUBLESHOOTING

Battery undercharging (voltage not raised to regulated voltage).

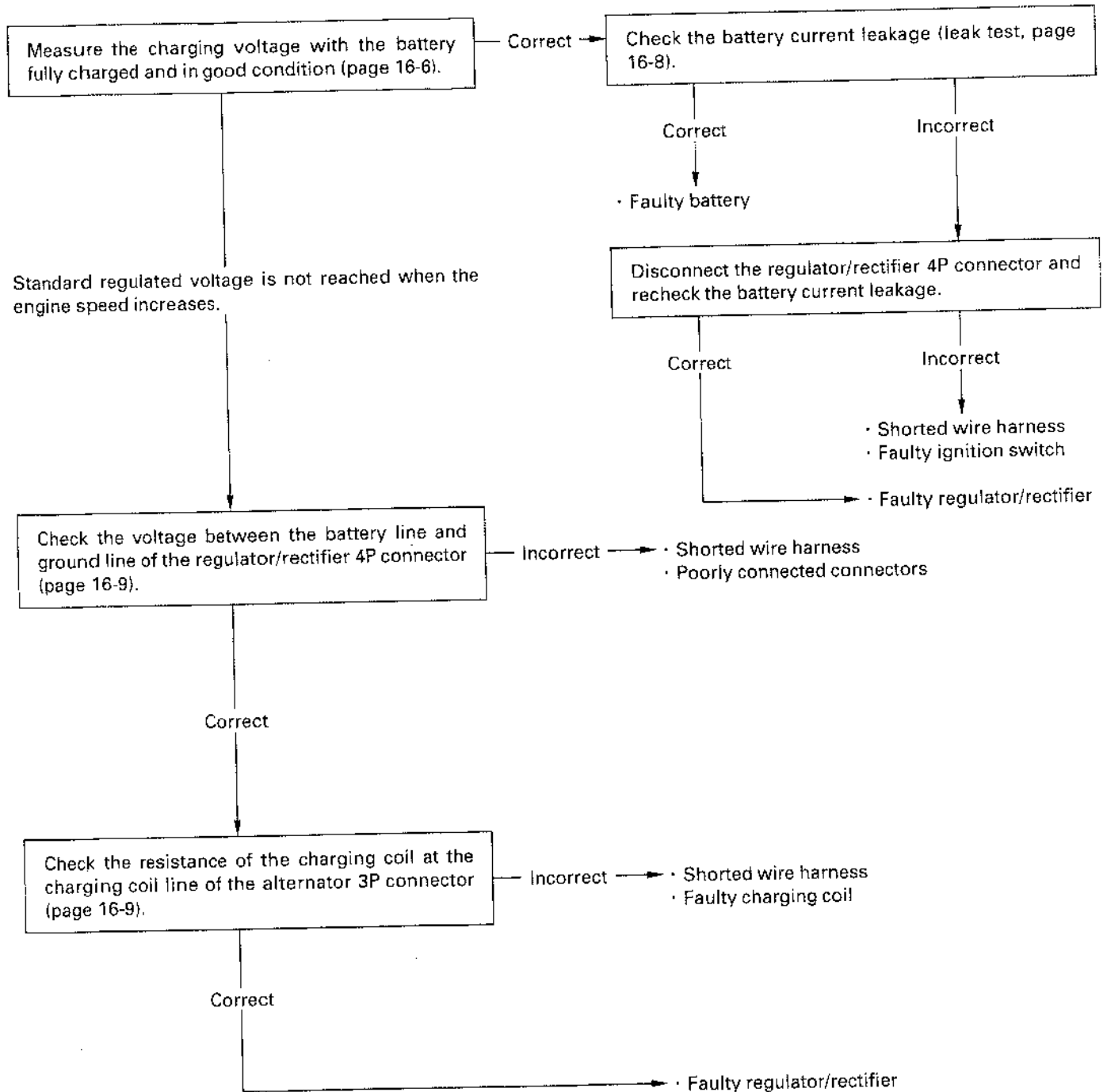

## BATTERY/CHARGING SYSTEM

---

Battery overcharging (regulated voltage too high).

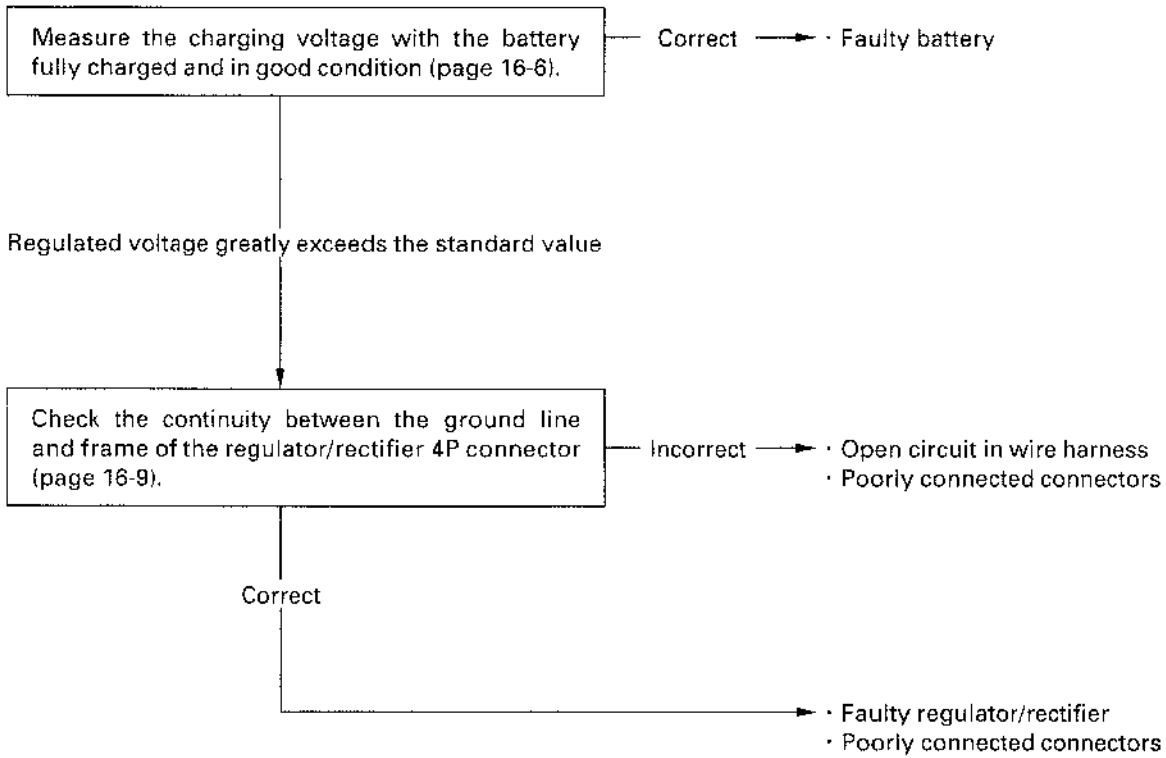

**BATTERY**

**REMOVAL**

**NOTE:**

Always turn the ignition switch OFF before removing or installing the battery.

Remove the right side cover (page 2-3).  
Remove the rubber cover and unhook the fuse box from the battery case cover.  
Remove the battery case cover by removing the bolts.

Remove the left side cover (page 2-3).

**NOTE:**

Disconnect the battery negative cable first, then positive cable from the battery.

Remove the negative cable cover.  
Remove the bolt and battery negative cable.  
Remove the positive cable cover.  
Remove the bolt and battery positive cable.  
Pull the battery out of the battery case.

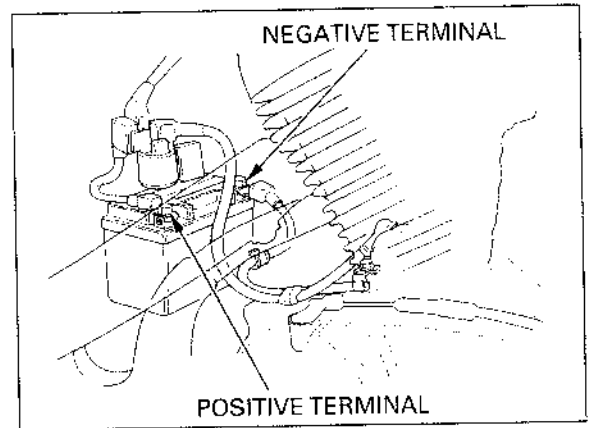
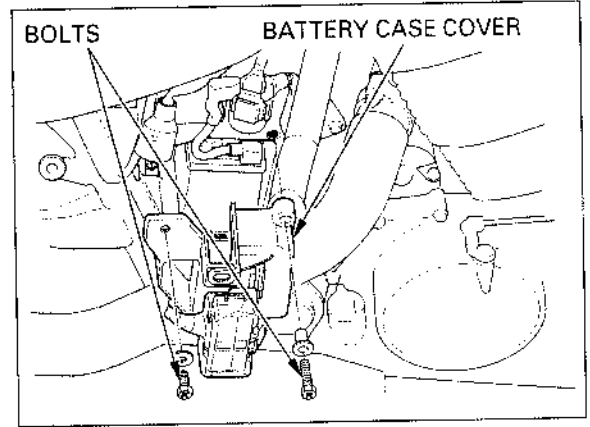

**INSTALLATION**

Place the battery into the case and connect the battery positive cable to the battery first from the right side, then connect the negative cable from the left side.

Coat the battery terminal with clean grease.  
Install the battery case cover by hooking the tab on the cover to the hook on the case.  
Install and tighten the cover mounting bolts.  
Install the fuse box onto the battery case cover.

Install the rubber cover in the sequence as shown.  
Install the right and left side covers (page 2-3).

Route the battery cables as shown on the battery caution label.

**NOTE:**

Pull the cover over the positive terminal.

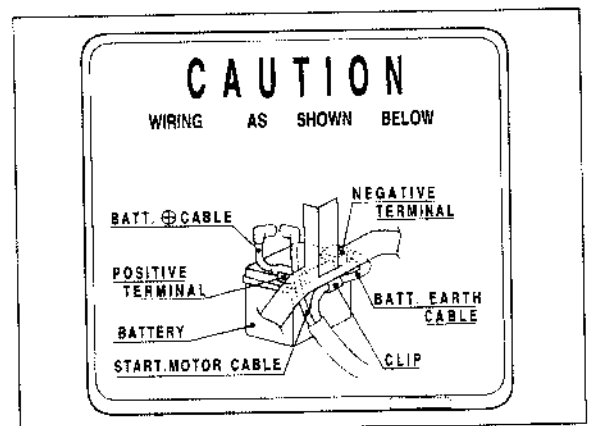
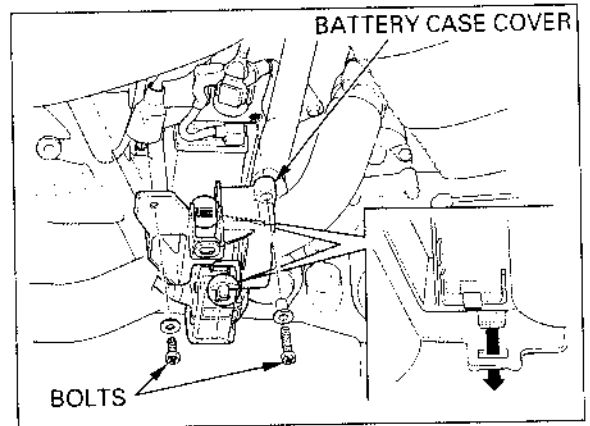

## BATTERY/CHARGING SYSTEM

### INSPECTION

Measure the battery voltage using a commercially available digital multimeter.

**VOLTAGE:** Fully charged: 13.0 – 13.2 V  
Under charged: Below 12.3 V

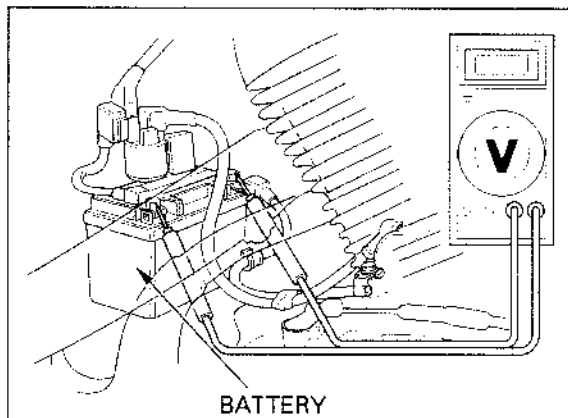

### BATTERY CHARGING

#### **⚠ WARNING**

- *The battery gives off explosive gases; keep sparks, flames and cigarettes away. Provide adequate ventilation when charging.*
- *The battery contains sulfuric acid (electrolyte). Contact with skin or eyes may cause severe burns. Wear protective clothing and a face shield.*
  - *If electrolyte gets on your skin, flush with water.*
  - *If electrolyte gets in your eyes, flush with water for at least 15 minutes and call a physician immediately.*
- *Electrolyte is poisonous. If swallowed, drink large quantities of water or milk and follow with milk of magnesia or vegetable oil and call a physician.*
- *Turn power ON/OFF at the charger, not at the battery terminals.*

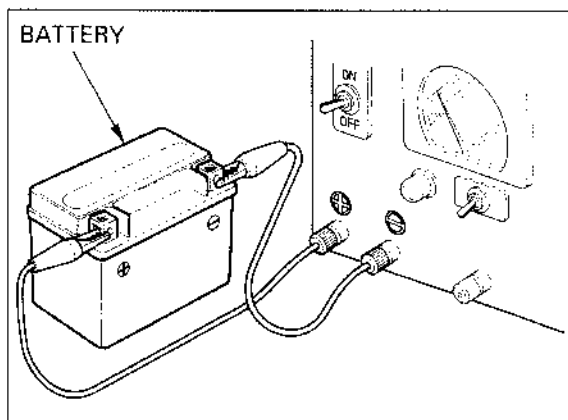

Remove the battery (page 16-5).

Connect the charger positive (·) cable to the battery positive (+) terminal.  
Connect the charger negative (–) cable to the battery negative (–) terminal.

#### **CHARGING CURRENT/TIME**

**Standard:** 0.8 A/10 h  
**Quick:** 4.0 A/1 h max

#### **CAUTION:**

- *Quick-charging should only be done in an emergency; slow charging is preferred.*
- *For battery charging, do not exceed the charging current and time specified on the battery. Using excessive current or extending the charging time may damage the battery.*

## CHARGING SYSTEM INSPECTION

### NOTE:

- Measuring circuits with a large capacity that exceeds the capacity of the tester may cause damage to the tester. Before starting each test, set the tester at the high capacity range first, then gradually down to low capacity ranges in order to ensure that you have the correct range and do not damage the tester.
- When measuring small capacity circuits, keep the ignition switch off. If the switch is suddenly turned on during a test, the tester fuse may blow.

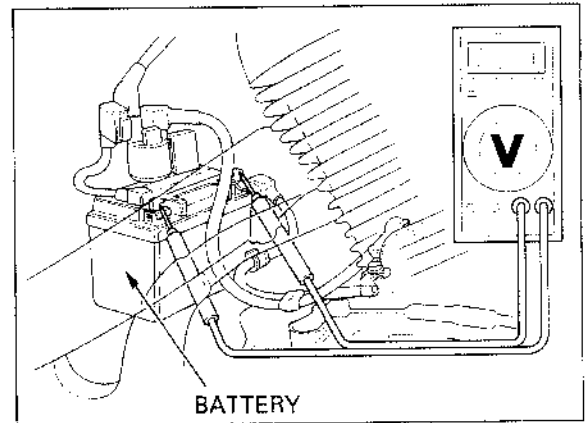

## REGULATED VOLTAGE INSPECTION

### ▲WARNING

- *If the engine must be running to do some work, make sure the area is well-ventilated. Never run the engine in an enclosed area.*
- *The exhaust contains poisonous carbon monoxide gas that may cause loss of consciousness and may lead to death.*

Remove the battery (page 16-5) and install the fully charged battery.

Start the engine and warm it up to the operating temperature; stop the engine.

Connect the multimeter between the positive and negative terminals of the battery.

### CAUTION:

- *To prevent short, make absolutely certain which are the positive and negative terminals or cable.*
- *Do not disconnect the battery or any cable in the charging system without first switching off the ignition switch. Failure to follow this precaution can damage the tester or electrical components.*

With the headlight to Lo beam, restart the engine. Measure the voltage on the multimeter when the engine runs at 5,000 rpm.

**REGULATED VOLTAGE:** 13.5 – 14.0 V/5,000 rpm

The battery is normal if the voltage reads the regulated voltage on the tester.

### NOTE:

The speed at which voltage starts to rise cannot be checked as it varies with the temperature and loads on the generator.

## BATTERY/CHARGING SYSTEM

A frequently discharged battery is an indication that it is deteriorated even if it proves normal in the regulated voltage inspection. The charging circuit may be abnormal if any of the following symptoms is encountered:

### 1. Voltage not raised to regulated voltage (page 16-3)

- Open or shorted circuit in the charging system wire harness or poorly connected connector
- Open or shorted of the alternator
- Faulty regulator/rectifier

### 2. Regulated voltage too high (page 16-4)

- Poorly grounded voltage regulator/rectifier
- Faulty battery
- Faulty regulator/rectifier

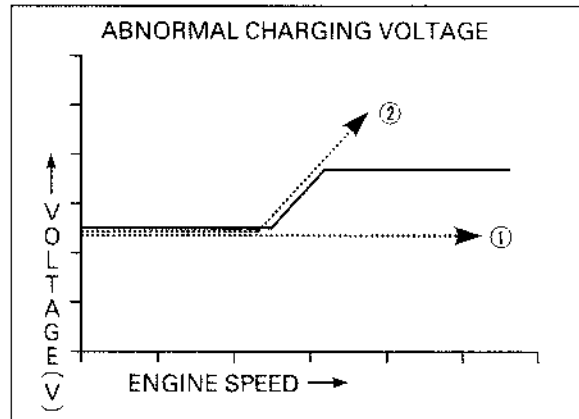
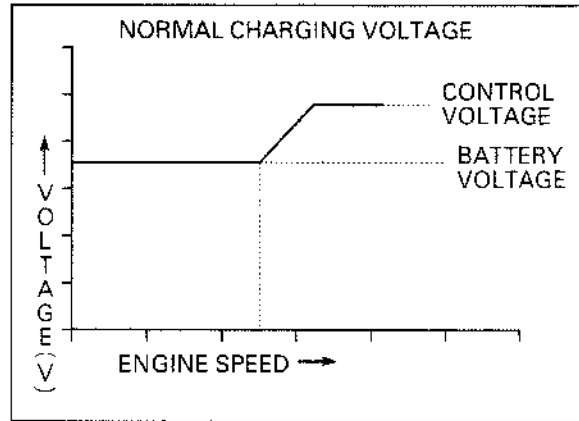

## CURRENT LEAKAGE TEST

Remove the battery cover (page 16-5).

Turn the ignition switch off, and disconnect the negative (-) cable from the battery. Connect the ammeter (+) probe to the battery negative cable and the ammeter (-) probe to the battery (-) terminal. With the ignition switch off, check for current leakage.

### NOTE:

- When measuring current using a tester, set it to a high range, and then bring the range down to an appropriate level. Current flow higher than the range selected may blow out the fuse in the tester.
- While measuring current, do not turn the ignition on. A sudden surge of current may blow out the fuse in the tester.

**SPECIFIED CURRENT LEAKAGE:** 1.3 mA max.

If current leakage exceeds the specified value, a shorted circuit is likely. Locate the short by disconnecting connections one by one and measuring the current.

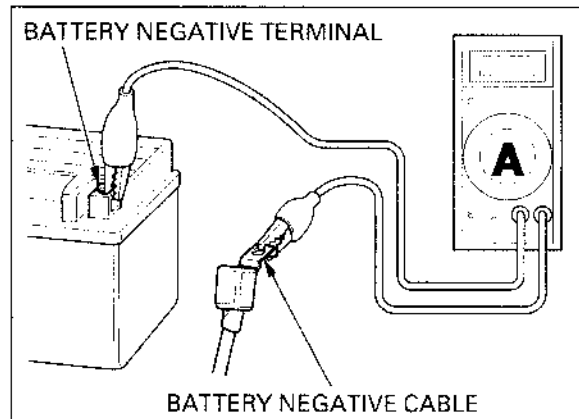



## REGULATOR/RECTIFIER

### WIRE HARNESS INSPECTION

Remove the left side cover (page 2-3).

Disconnect the regulator/rectifier 3P and 4P connectors.

Check the connectors for loose or corroded terminals.

### BATTERY LINE

Make sure the battery voltage between Red/White (+) and Green (-).

If there is no voltage, measure the following;

Item	Terminals	Specification
Battery charging line	Red/White (+) and ground (-)	Battery voltage should register
Ground line	Green and ground	Continuity exists

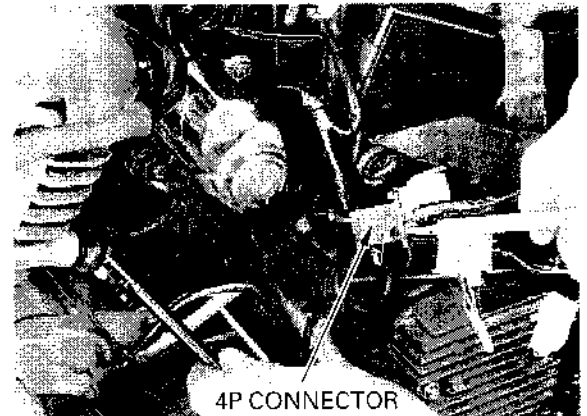
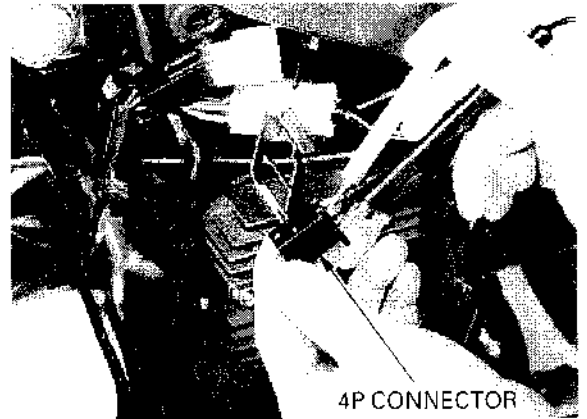

### CHARGING LINE

#### NOTE:

It is not necessary to remove the stator coil to complete this test.

Measure the resistance between the connector terminals and ground.

**CONNECTION: Yellow and Yellow**

**STANDARD: 0.1 – 1.0  $\Omega$  (20°C/68°F)**

If the charging coil reading is out of specification, replace the stator (page 9-2).

Check for continuity between the connector terminals and ground. There should be no continuity.

If there is continuity between the connector and ground, replace the stator (page 9-2).

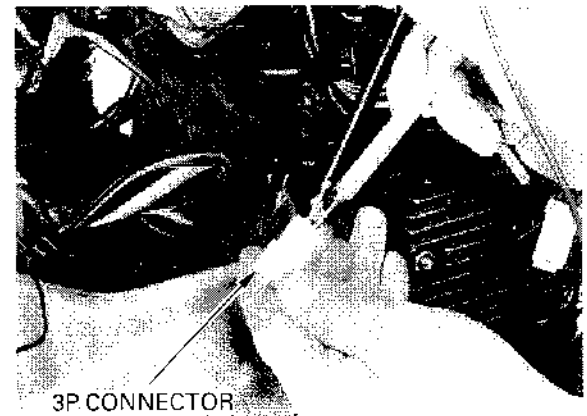

## BATTERY/CHARGING SYSTEM

### REMOVAL/INSTALLATION

Remove the left side cover (page 2-3).

Disconnect the regulator/rectifier 3P and 4P connectors.

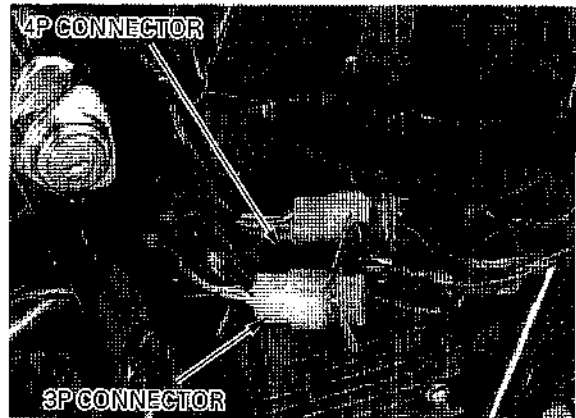

Remove the nuts and regulator/rectifier unit.

Installation is in the reverse order of removal.

**NOTE:**

Route the wire harness properly (page 1-26).

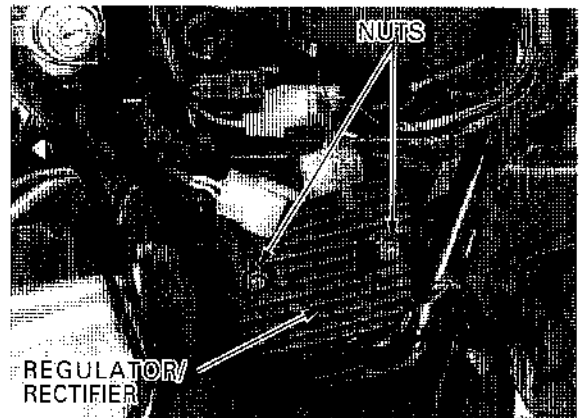

---

MEMO

---

# IGNITION SYSTEM

'97 - '98:

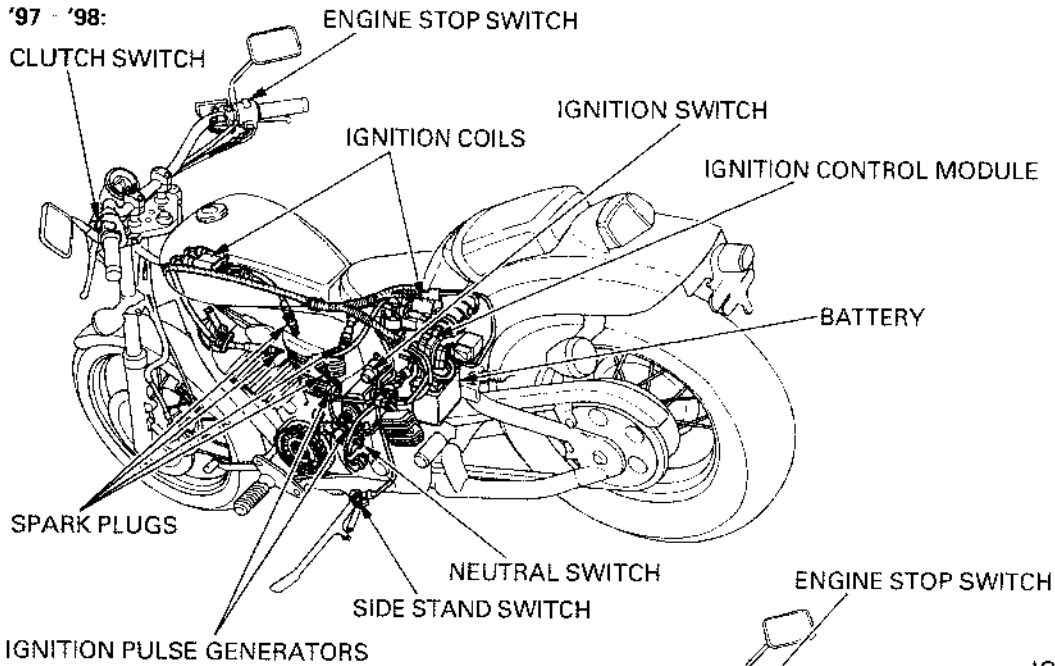

After '98:

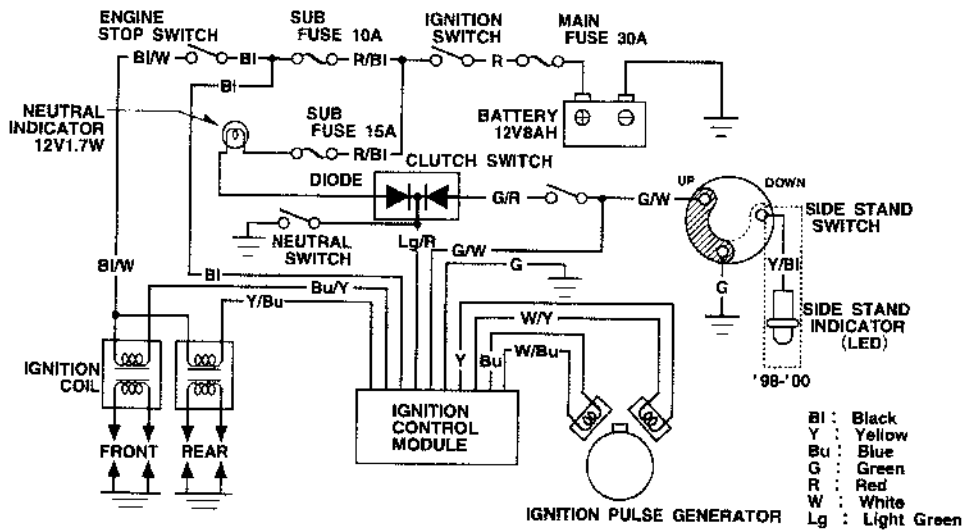
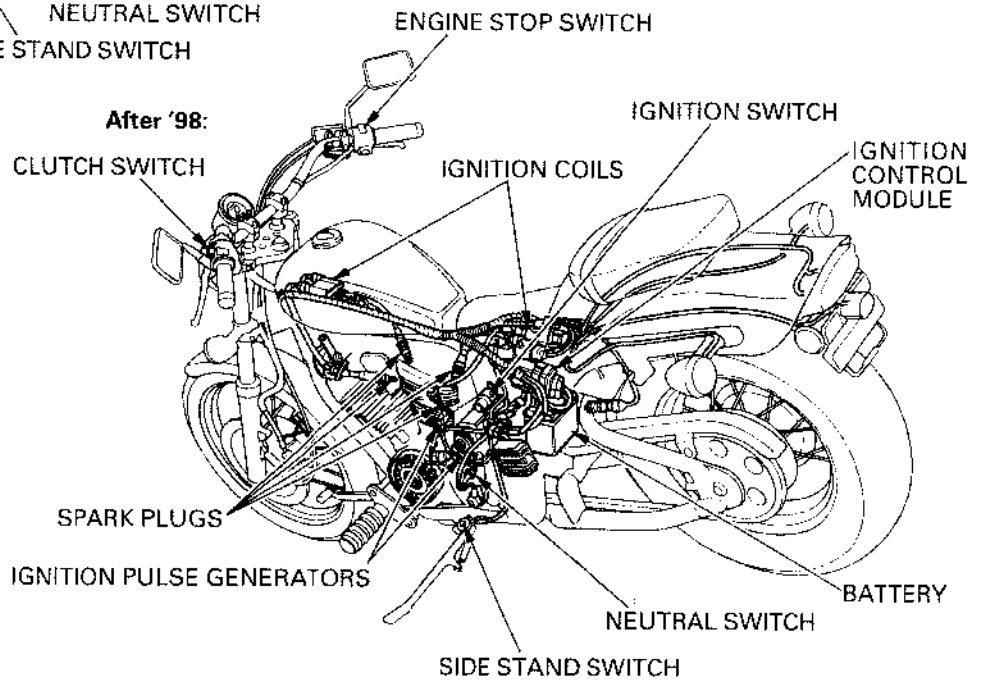

# 17. IGNITION SYSTEM

SYSTEM DIAGRAM	17-0	IGNITION CONTROL MODULE (ICM)	17-7
SERVICE INFORMATION	17-1	IGNITION COIL	17-8
TROUBLESHOOTING	17-3	IGNITION TIMING	17-9
IGNITION SYSTEM INSPECTION	17-4		

## SERVICE INFORMATION

### GENERAL

#### ▲WARNING

*When the engine must be running to do some work, make sure the area is well-ventilated. Never run the engine in an enclosed area. The exhaust contains poisonous carbon monoxide gas that may cause loss of consciousness and lead to death. Run the engine in an open area or with an exhaust evacuation system in an enclosed area.*

#### CAUTION:

*Some electrical components may be damaged if terminals or connectors are connected or disconnected while the ignition switch is ON and a current is present.*

- When checking the ignition system, always follow the steps in the troubleshooting (page 17-3).
- Ignition timing cannot be adjusted since the Ignition Control Module (ICM) is non-adjustable. If ignition timing is incorrect, check the system components and replace any faulty parts.
- The ICM may be damaged if dropped. Also, if the connector is disconnected when current is flowing, the resulting excessive voltage may damage the unit. Always turn off the ignition switch before servicing.
- A faulty ignition system is often related to poorly connected or corroded connectors. Check those connections before proceeding. Make sure the battery is adequately charged. Using the starter motor with a weak battery results in a slower engine cranking speed as well as no spark at the spark plugs.
- Use spark plugs of the correct heat range. Using a spark plug of an incorrect heat range can damage the engine.
- For neutral switch and side stand switch inspection and removal/installation see section 19.
- For engine stop switch and ignition switch inspection and removal/installation see section 19.

### SPECIFICATIONS

ITEM		SPECIFICATIONS	
Spark plug	Standard	DPR8EA-9 (NGK)	X24EPR-U9 (DENSO)
	For cold climate (below 5 °C/41 °F)	DPR7EA-9 (NGK)	X22EPR-U9 (DENSO)
	For extended high speed riding	DPR9EA-9 (NGK)	X27EPR-U9 (DENSO)
Spark plug gap		0.80 - 0.90 mm (0.031 - 0.035 in)	
Ignition coil primary peak voltage		100 V minimum	
Ignition pulse generator peak voltage		0.7 V minimum	
Ignition timing "F" mark		6.5° BTDC at idle	
Advance	Start	'97 - '98	2,000 ± 200 rpm
		After '98	1,800 ± 200 rpm
	Stop	6,000 ± 200 rpm	
Full advance		BTDC 30°	

## IGNITION SYSTEM

---

### TORQUE VALUES

Timing hole cap	15 N·m (1.5 kgf·m , 11 lbf·ft)	Apply molybdenum disulfide oil to the threads
-----------------	--------------------------------	---

### TOOLS

Peak voltage tester or Peak voltage adapter	07HGJ-0020100 with Commercially available digital multimeter (impedance 10 M $\Omega$ /DCV minimum)
---	---

## TROUBLESHOOTING

- Inspect the following before diagnosing the system.
  - Faulty spark plug
  - Loose spark plug cap or spark plug wire connections
  - Water got into the spark plug cap (Leaking to the ignition coil secondary voltage)
- If there is no spark at either cylinders, temporarily exchange the ignition coil with the other good one and perform the spark test. If there is a spark, the exchanged ignition coil is faulty.
- "Initial voltage" of the ignition primary coil is the battery voltage with the ignition switch ON and engine stop switch at RUN (The engine is not cranked by the starter motor).

### No spark at all plugs

	Unusual condition	Probable cause (Check in numerical order)
Ignition coil primary voltage	No initial voltage with ignition and engine stop switches ON. (Other electrical components are normal)	<ol style="list-style-type: none"> <li>1. Blown Sub fuse (10 A).</li> <li>2. An open circuit in Black wire between the sub fuse (10 A) and ICM.</li> <li>3. Faulty engine stop switch.</li> <li>4. An open circuit in Black/White wire between the ignition coil and engine stop switch.</li> <li>5. Loose primary terminal or an open circuit in primary coil.</li> <li>6. Faulty ICM (in case when the initial voltage is normal while disconnecting ICM connectors).</li> </ol>
	Initial voltage is normal, but it drops down to 2 – 4 V while cranking the engine.	<ol style="list-style-type: none"> <li>1. Incorrect peak voltage adapter connections.</li> <li>2. Undercharged battery.</li> <li>3. No voltage between the Black/White (+) and Body ground (-) at the ICM connector or loose ICM connection.</li> <li>4. An open circuit or loose connection in Green wire.</li> <li>5. An open circuit or loose connection in Yellow/Blue and Blue/Yellow wires between the ignition coils and ICM.</li> <li>6. Short circuit in ignition primary coil.</li> <li>7. Faulty side stand switch or neutral switch.</li> <li>8. An open circuit or loose connection in No. 7 related circuit wires.                             <ul style="list-style-type: none"> <li>· Side stand switch line: Green/White wire</li> <li>· Neutral switch line: Light Green/Red wire</li> </ul> </li> <li>9. Faulty ignition pulse generator (measure the peak voltage).</li> <li>10. Faulty ICM (in case when above No. 1 – 9 are normal).</li> </ol>
	Initial voltage is normal, but no peak voltage while cranking the engine.	<ol style="list-style-type: none"> <li>1. Faulty peak voltage adapter connections.</li> <li>2. Faulty peak voltage adapter.</li> <li>3. Faulty ICM (in case when above No. 1, 2 are normal).</li> </ol>
	Initial voltage is normal, but peak voltage is lower than standard value.	<ol style="list-style-type: none"> <li>1. The multimeter impedance is too low: below 10 MΩ/DCV.</li> <li>2. Cranking speed is too low (battery undercharged).</li> <li>3. The sampling timing of the tester and measured pulse were not synchronized (system is normal if measured voltage is over the standard voltage at least once).</li> <li>4. Faulty ICM (in case when above No. 1 – 3 are normal).</li> </ol>
	Initial and peak voltage are normal, but does not spark.	<ol style="list-style-type: none"> <li>1. Faulty spark plug or leaking ignition coil secondary current ampere.</li> <li>2. Faulty ignition coil.</li> </ol>
Ignition pulse generator	Peak voltage is lower than standard value.	<ol style="list-style-type: none"> <li>1. The multimeter impedance is too low: below 10 MΩ/DCV.</li> <li>2. Cranking speed is too low (battery undercharged).</li> <li>3. The sampling timing of the tester and measured pulse were not synchronized (system is normal if measured voltage is over the standard voltage at least once).</li> <li>4. Faulty ICM (in case when above No. 1 – 3 are normal).</li> </ol>
	No peak voltage.	<ol style="list-style-type: none"> <li>1. Faulty peak voltage adapter.</li> <li>2. Faulty ignition pulse generator.</li> </ol>

### IGNITION SYSTEM INSPECTION

#### NOTE:

- If there is no spark at either plug, check all connections for loose or poor contact before measuring each peak voltage.
- Use the recommended digital multimeter or commercially available digital multimeter with an impedance of 10 M $\Omega$ /DCV minimum.
- The display value differs depending upon the internal impedance of the multimeter.
- If using an Imrie diagnostic tester (model 625), follow the manufacture's instructions.

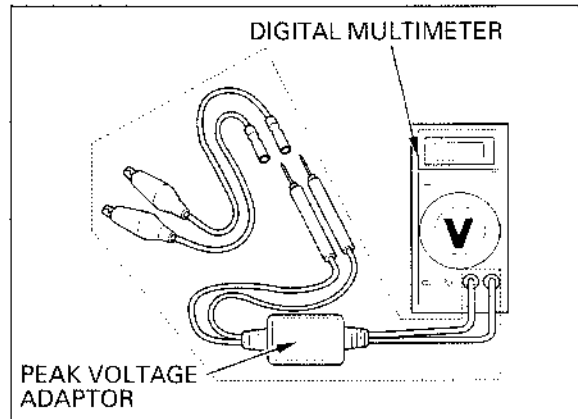

Connect the peak voltage adapter to the digital multimeter, or use the Imrie diagnostic tester.

#### TOOLS:

Peak voltage tester or  
Peak voltage adaptor 07HGJ-0020100 with  
Commercially available digital multimeter  
(impedance 10 M $\Omega$ /DCV minimum)

### IGNITION PRIMARY VOLTAGE INSPECTION

#### NOTE:

- Check all system connections before the inspection. If the system is disconnected, an incorrect peak voltage will register.
- Check cylinder compression at each cylinder and check that the spark plugs are installed correctly in each cylinder.

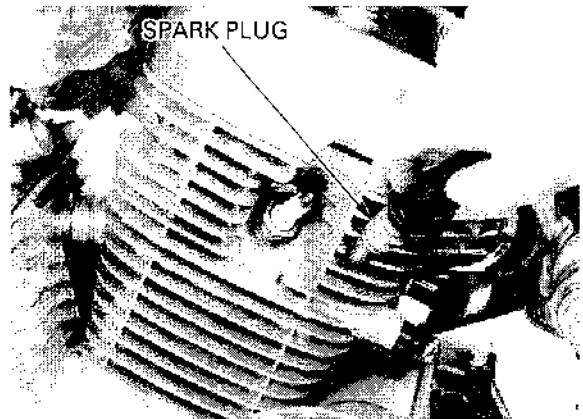

Support the motorcycle using the side stand.

Disconnect the spark plug caps from the spark plugs on the cylinder head.

Connect a good known spark plug to each spark plug cap and ground the spark plugs to the cylinder as done in a spark test.



When servicing the front ignition coil as following:  
 Remove the fuel tank (page 2-4).  
 -- Remove the crankcase breather tank with bolt (page 17-8).

When servicing the rear ignition coil as following:  
 -- Remove the right side cover (page 2-4).

Connect the peak voltage adaptor or peak voltage tester to the ignition coil primary terminal.

**NOTE:**

Do not disconnect the ignition coil primary wires.

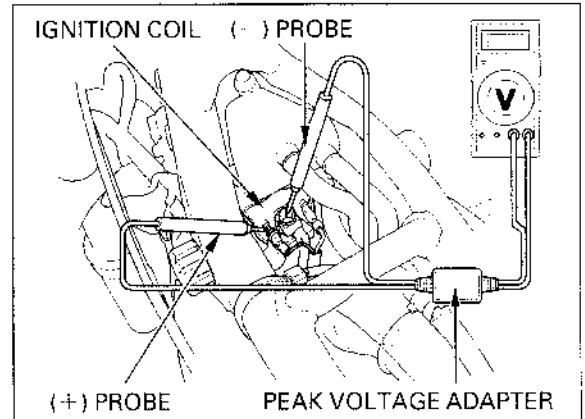

**TOOLS:**

Peak voltage tester or  
 Peak voltage adaptor 07HGJ - 0020100  
 with Commercially available digital multimeter  
 (impedance 10 M $\Omega$ /DCV minimum)

**CONNECTION:**

**Front ignition coil:**

Blue/Yellow (+) -- Body ground (-)

**Rear ignition coil:**

Yellow/Blue (+) -- Body ground (-)

Turn the ignition switch "ON" and engine stop switch to "RUN".

Check for initial battery voltage.

If battery voltage is not present, follow the checks described in the troubleshooting on page 17-3.

Shift the transmission into neutral.

Crank the engine with the starter motor and read each ignition coil primary voltage.

**PEAK VOLTAGE:** 100 V minimum

**▲WARNING**

*Avoid touching the spark plugs and tester probes to prevent electric shock.*

**NOTE:**

Although measured values are different for each ignition coil, they are normal as long as the voltage is higher than the standard value.

If the peak voltage is lower than the standard value, follow the checks described in the troubleshooting on page 17-3.

## IGNITION PULSE GENERATOR PEAK VOLTAGE INSPECTION

### NOTE:

- Check all system connection before the inspection. If the system is disconnected, an incorrect peak voltage will register.
- Check cylinder compression at each cylinder and check that the spark plugs are installed correctly in each cylinder.

Remove the ignition control module (ICM) (page 17-7).

Disconnect the ignition control module (ICM) 4P connector.

Connect the peak voltage adaptor to the 4P connector wire harness side.

### TOOLS:

Peak voltage tester or  
Peak voltage adaptor 07HGJ 0020100 with  
Commercially available digital multimeter  
(impedance 10 M $\Omega$  /DCV minimum)

### CONNECTION:

Front cylinder: White/Blue (+) – Blue (-)

Rear cylinder: White/Yellow (+) – Yellow (-)

Turn the ignition switch "ON" and engine stop switch to "RUN".

Shift the transmission into neutral.

Crank the engine with the starter motor and read the ignition pulse generator peak voltage.

**PEAK VOLTAGE:** 0.7 V minimum

### **▲WARNING**

*Avoid touching the spark plugs and tester probes to prevent electric shock.*

If the peak voltage is lower than standard value, perform the following procedure.

Remove the left steering cover (page 2-2).

Disconnect the ignition pulse generator 4P connector.

Turn the ignition switch "ON" and engine stop switch to "RUN".

Shift the transmission into neutral.

Crank the engine with the starter motor and measure the peak voltage at the 4P connector ignition pulse generator side and record it.

### CONNECTION:

Front cylinder: White/Blue (+) – Blue (-)

Rear cylinder: White/Yellow (-) – Yellow (-)

**PEAK VOLTAGE:** 0.7 V minimum

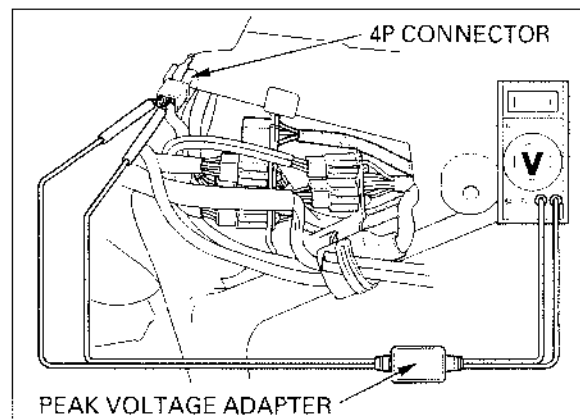
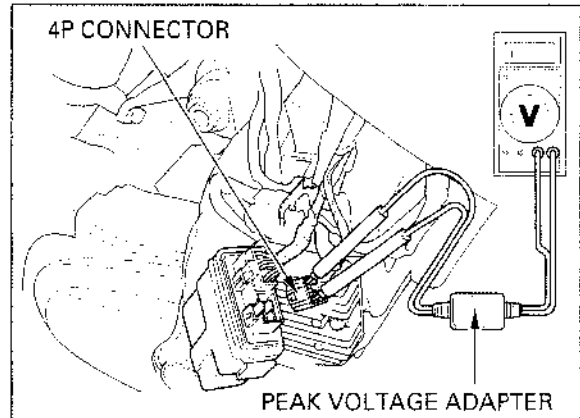

Compare their values at the ignition control module (ICM) 4P connector and the ignition pulse generator 4P connector.

If the value at the ignition pulse generator is normal, but abnormal at the ignition control module (ICM):

- Open circuit in the ignition pulse generator wires
- Loosen connection in the ignition pulse generator connector

If both values are abnormal:

- The ignition pulse generator is likely to be faulty. Check and perform troubleshooting on page 17-3.
- For ignition pulse generator replacement, refer to section 8.

## IGNITION CONTROL MODULE (ICM)

### REMOVAL/INSTALLATION

Remove the left side cover (page 2-3).

Remove the connector mounting plate.  
Remove the rubber band, nuts and tool tray.

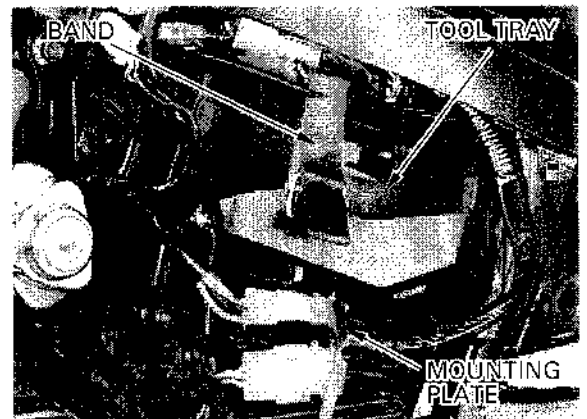

Remove the ignition control module (ICM) from the mounting stay.

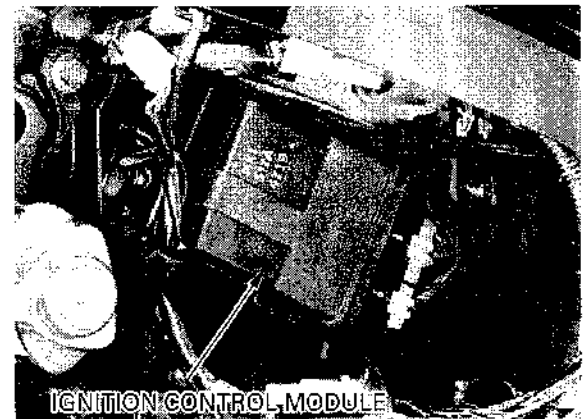

Disconnect the 6P and 4P connectors.

Installation is in the reverse order of removal.



### IGNITION COIL

#### REMOVAL/INSTALLATION

##### FRONT:

Disconnect the spark plug cap from the spark plug.  
Remove the fuel tank (page 2-3).  
Remove the crankcase breather separator with bolt.

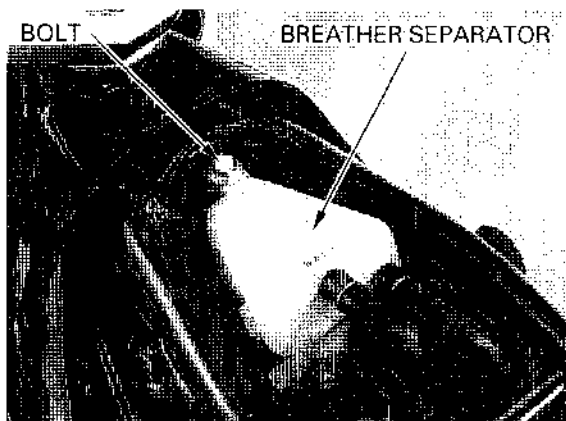

Disconnect the ignition coil primary wires from the terminals.  
Remove the bolts and ground wire eyelet.  
Remove the ignition coil.

Installation is in the reverse order of removal.

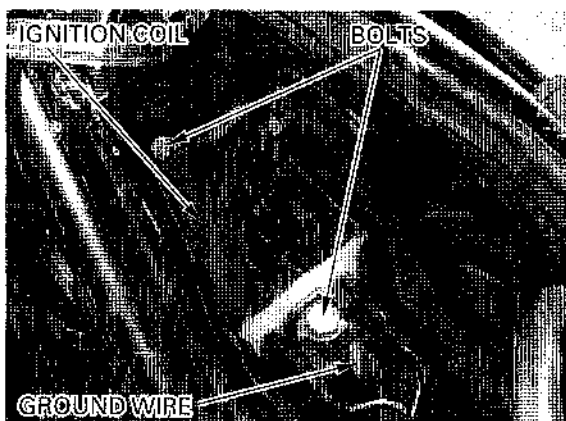

##### REAR:

Remove the right side cover (page 2-2).

Disconnect the spark plug caps from the spark plugs.  
Remove the bolts.  
Disconnect the ignition coil primary wires from the terminals and remove the ignition coil.

Installation is in the reverse order of removal.

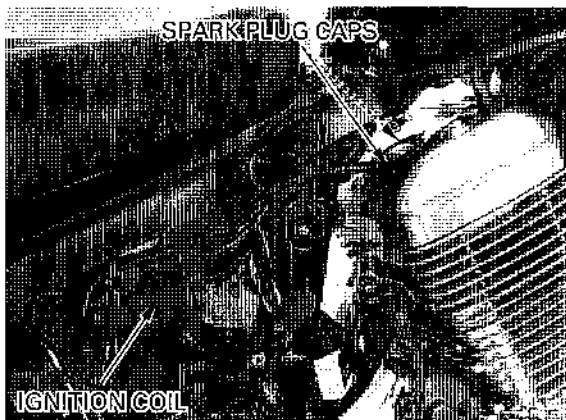

##### NOTE:

- Route the spark plug wires properly (page 1-22, 23).
- Connect the primary wires to the original position.  
Front:  
Black terminal: Black/White wire  
Green terminal: Blue/Yellow wire  
Rear:  
Black terminal: Black/White wire  
Green terminal: Yellow/Blue wire

## IGNITION TIMING

**▲WARNING**

*If the engine must be running to do some work, make sure the area is well ventilated. Never run the engine in an enclosed area. The exhaust contains poisonous carbon monoxide gas that may cause loss of consciousness and may lead to death. Run the engine in an open area or with an exhaust evacuation system in enclosed area.*

**NOTE:**

Read the manufacturer's instructions for the timing light before operating.

Warm up the engine.  
Stop the engine.

Remove the timing hole cap.

Connect a timing light to the rear (# 1) cylinder spark plug wire.  
Start the engine and let it idle.

**IDLE SPEED:** 1,200 ± 100 rpm

The timing is correct if the "F" mark on the flywheel aligns with the index mark on the left crankcase cover.

Increase the engine speed by rotating the throttle stop control knob.

The timing is correct if the advance marks on the flywheel align with the index mark on the left crankcase cover.

Stop the engine and connect the timing light to the front (# 2) cylinder spark plug wire.

Recheck the ignition timing at the front cylinder.

Coat the new O-ring with engine oil and install it in the timing hole cap groove.

Apply molybdenum disulfide oil to the timing hole cap threads and flange surface.

Install and tighten the timing hole cap to the specified torque.

**TORQUE:** 15 N·m (1.5 kgf·m , 11 lbf·ft)

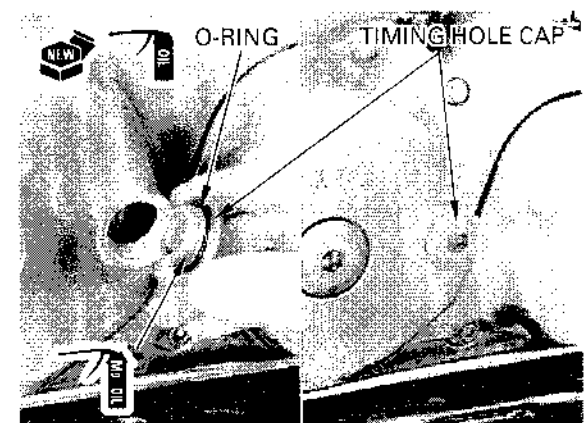
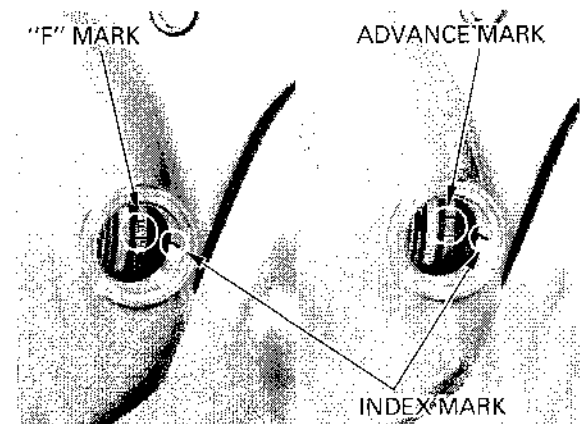
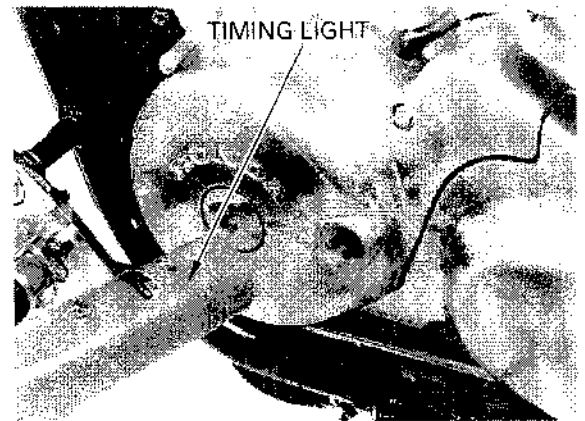
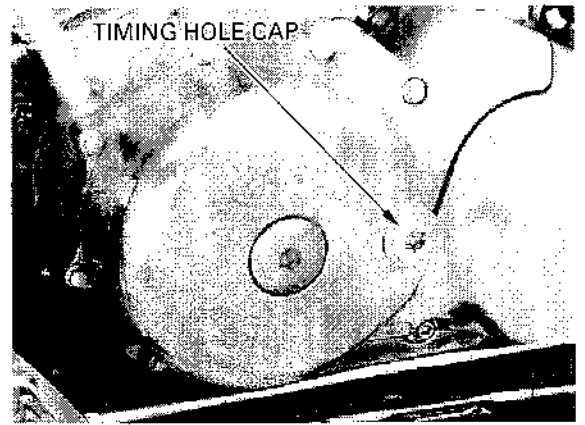

# ELECTRIC STARTER

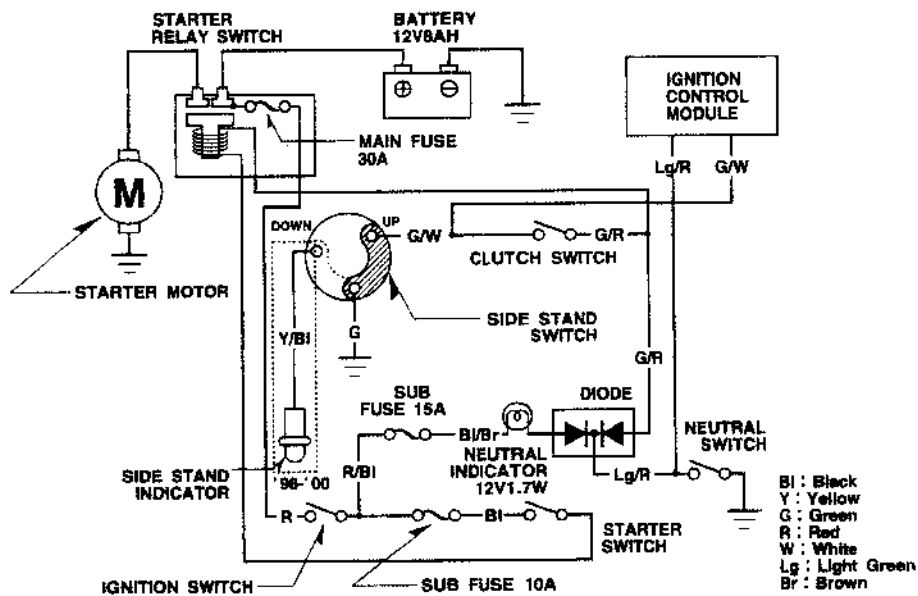
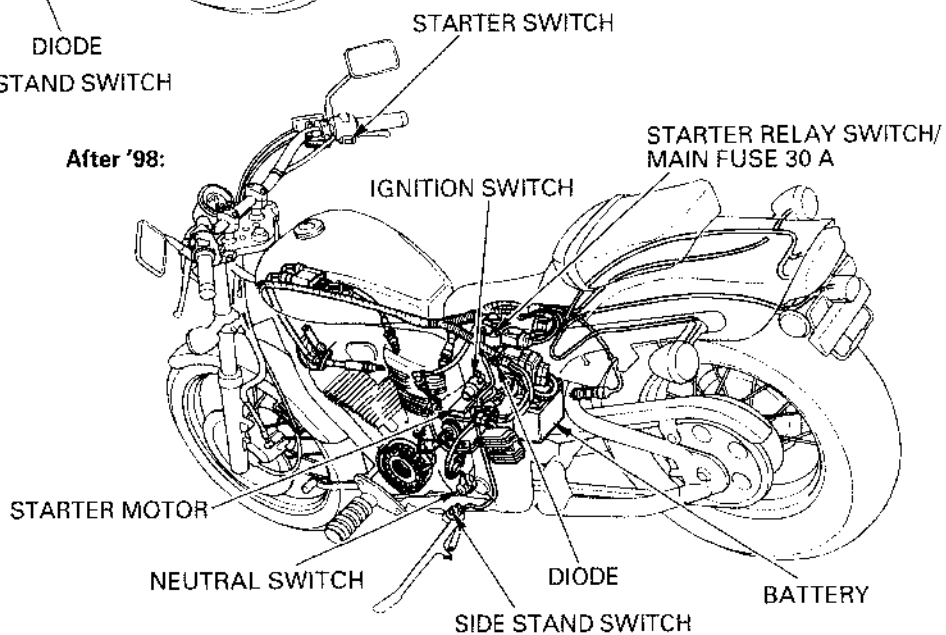
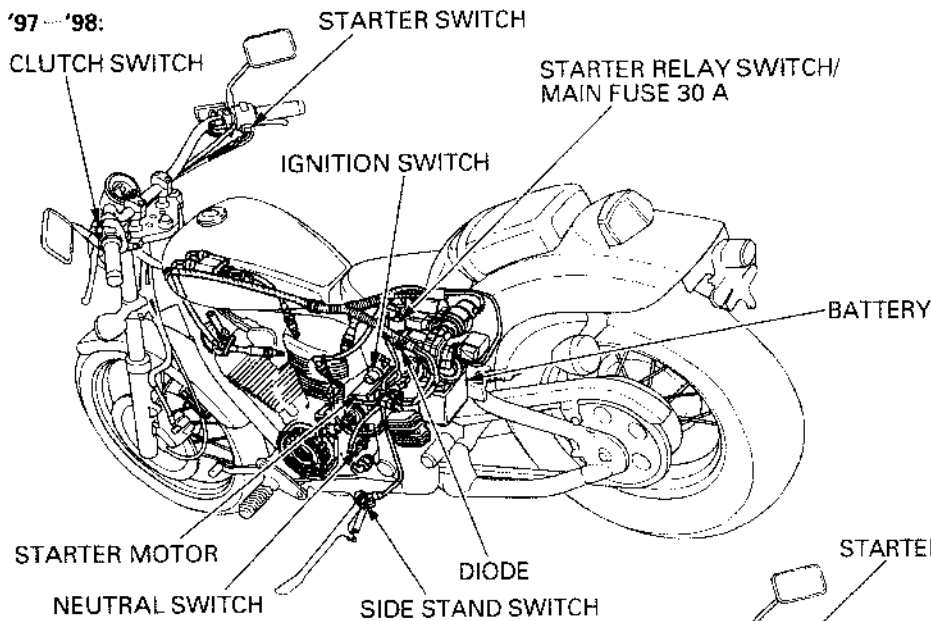

NEW

# 18. ELECTRIC STARTER

SYSTEM DIAGRAM	18-0	STARTER MOTOR	18-4
SERVICE INFORMATION	18-1	STARTER RELAY SWICTH	18-13
TROUBLESHOOTING	18-2	CLUTCH DIODE	18-14

## SERVICE INFORMATION

### GENERAL

#### ▲WARNING

*Always turn the ignition switch OFF before servicing the starter motor. The motor could suddenly start, causing serious injury.*

- When checking the starter system, always follow the steps in the troubleshooting flow chart (page 18-2).
- A weak battery may be unable to turn the starter motor quickly enough, or supply adequate ignition current.
- If current continues to flow through the starter motor while the engine is not cranking over, the starter motor may be damaged.
- Always turn off the ignition switch before disconnecting any electrical components.
- For following components inspections, refer to the following pages; for the parts locations, see page 18-0 of this manual.
  - Side stand switch (Section 19)
  - Neutral switch (Section 19)
  - Ignition switch (Section 19)
  - Starter switch (Section 19)
  - Clutch switch (Section 19)

### SPECIFICATIONS

Unit: mm (in)

ITEM	STANDARD	SERVICE LIMIT
Starter motor brush length	12.5 (0.49)	6.5 (0.26)

# ELECTRIC STARTER

## TROUBLESHOOTING

- Check for the following before troubleshooting the system.
  - Blown main fuse (30 A) or sub fuse (10 A, 15 A).
  - Loose battery and starter motor cable.
  - Discharged battery.
- The starter motor should turn when the transmission is in neutral.
- The starter motor should turn when transmission is in any gear as indicated the chart below.

Gear Position	Side Stand	Clutch Lever	Starter Motor
Any Gear	Up	Pulled in	Turn
		Released	Does not turn
	Down	Pulled in	Does not turn
		Released	Does not turn

### Starter motor will not turn

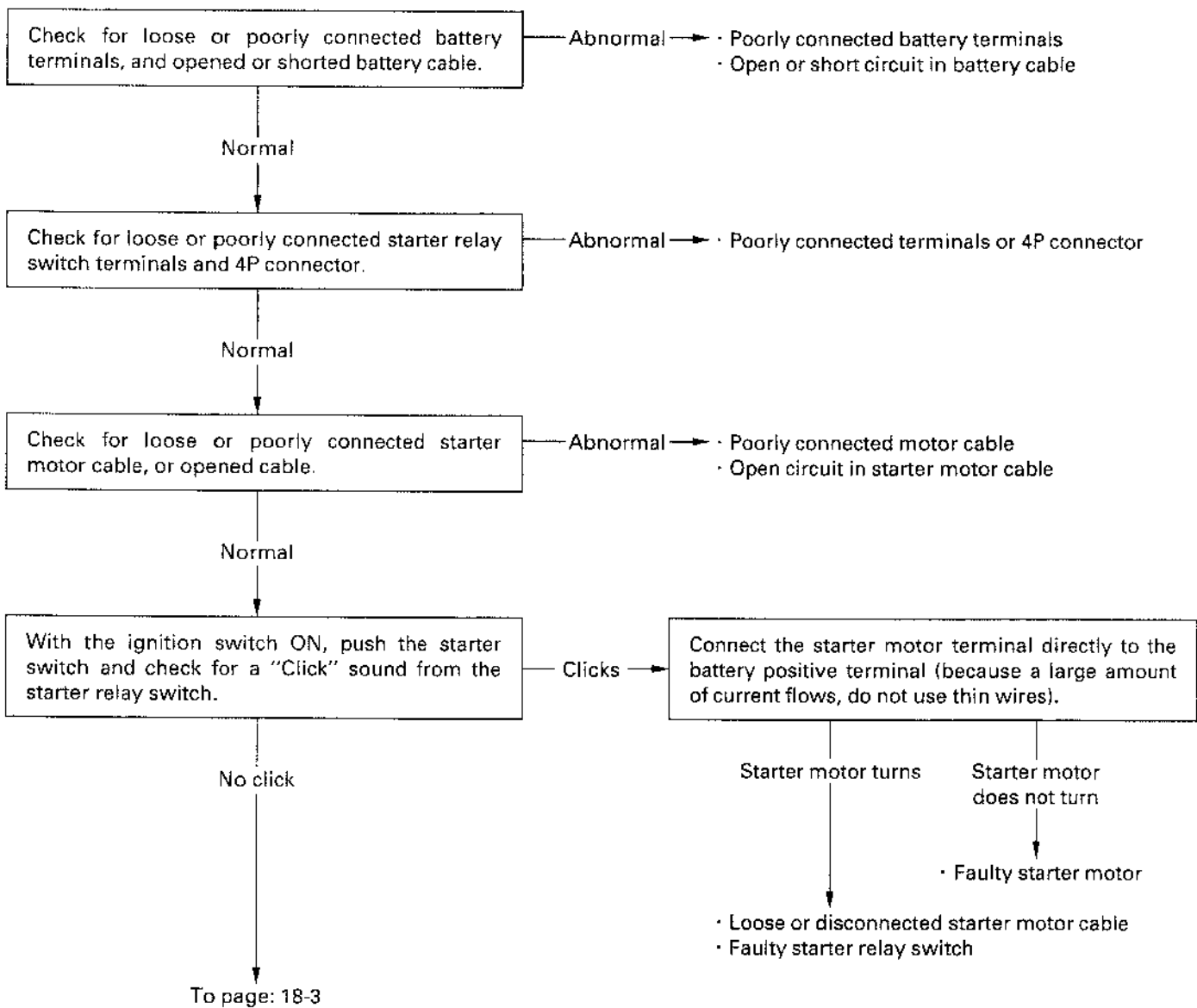



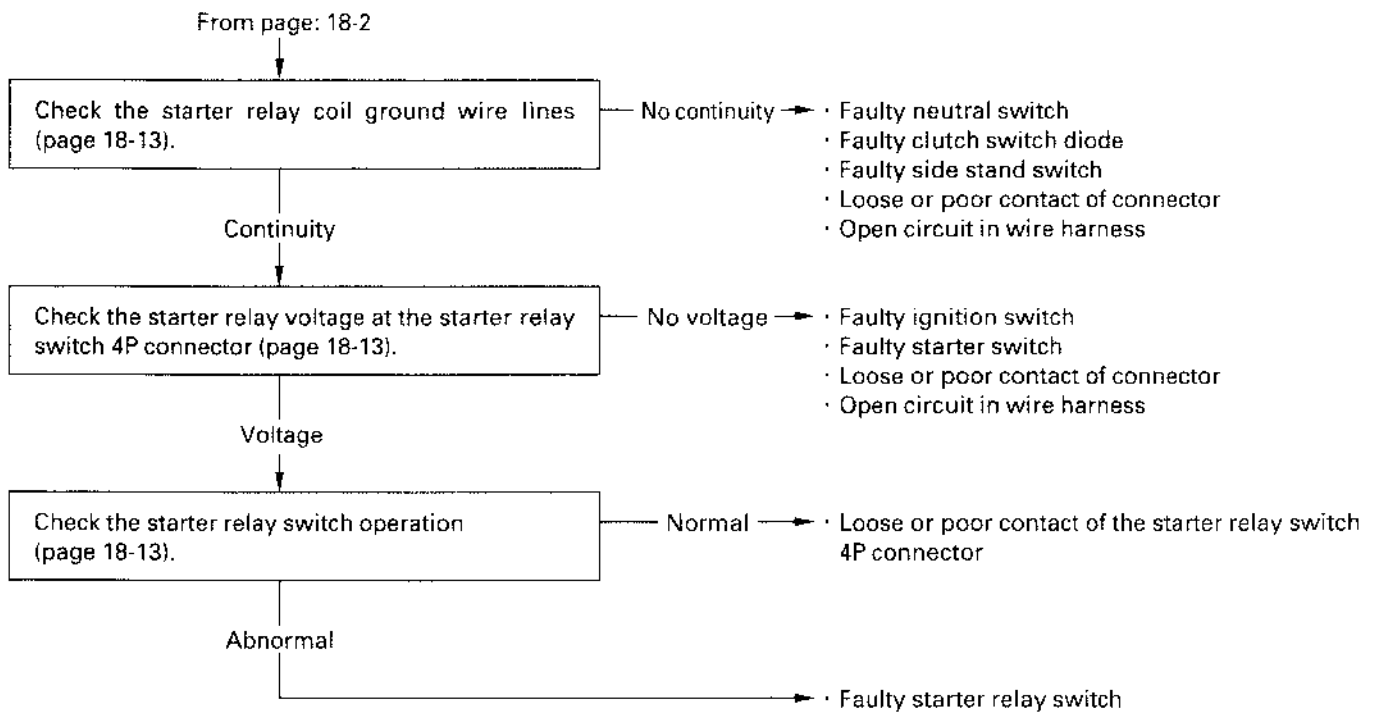

**NEW** The starter motor only turns when the transmission is in neutral.  
The side stand is up and the clutch lever is pulled in.

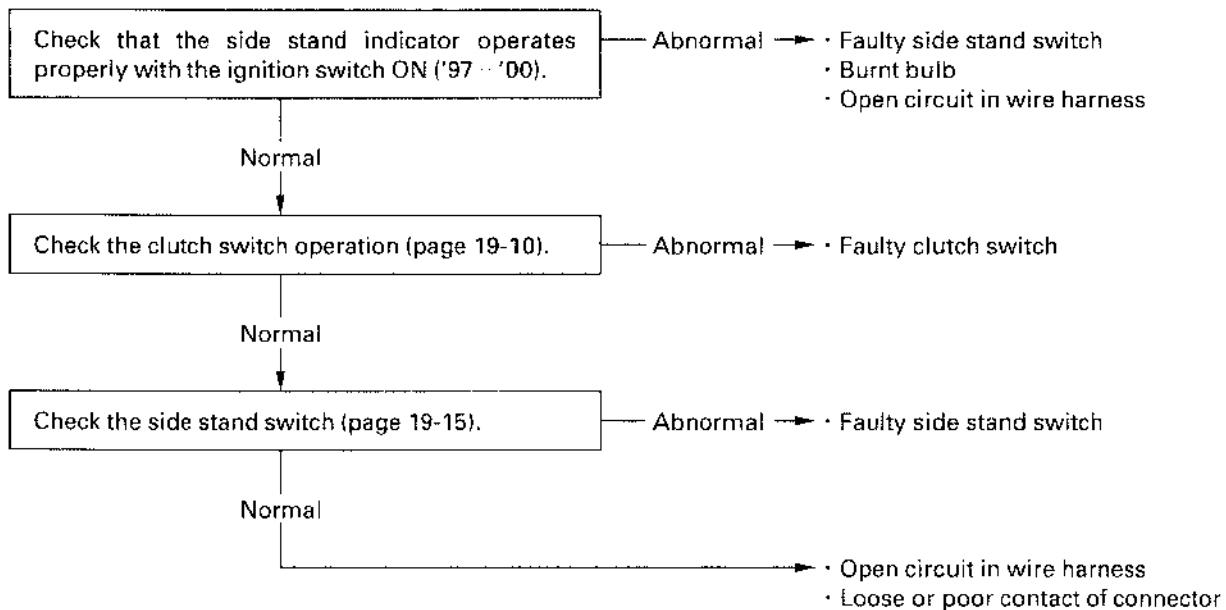

#### Starter motor turns slowly

- Poorly connected battery terminal cable
- Poorly connected starter motor cable
- Faulty starter motor
- Worn or damaged starter motor brush

#### Starter relay switch "clicks", but engine does not turn over

- Crankshaft does not turn due to engine problem
- Faulty starter reduction gear
- Faulty starter idle gear

#### Starter motor turns, but engine does not turn

- Starter motor is running backwards
  - Case assembled improperly
  - Terminals connected improperly
- Faulty starter clutch

## STARTER MOTOR

### REMOVAL

**▲WARNING**

*Always turn the ignition switch OFF before servicing the starter motor. The motor could suddenly start, causing serious injury.*

Remove the rubber cap and starter motor cable nut. Disconnect the starter motor cable.

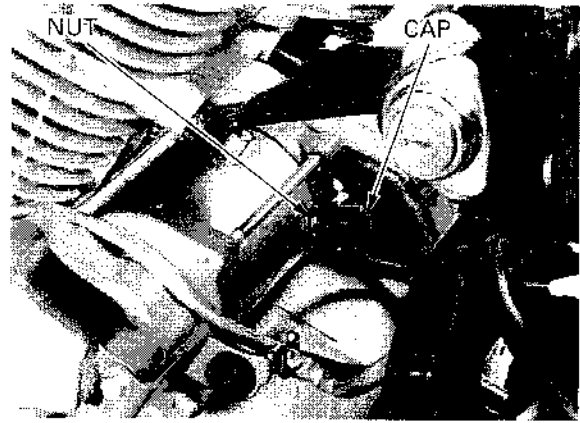

Remove the bolts and ground cable. Remove the starter motor.

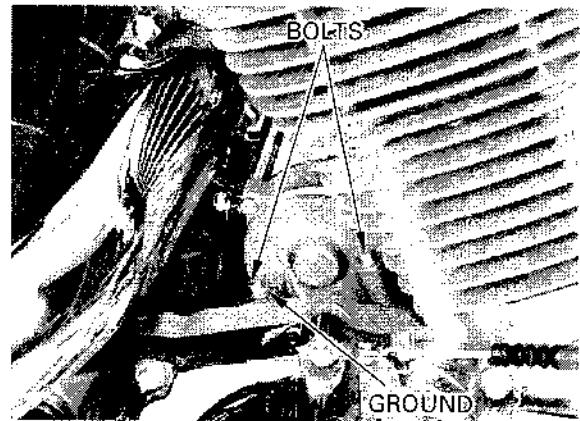

Remove the O-ring.

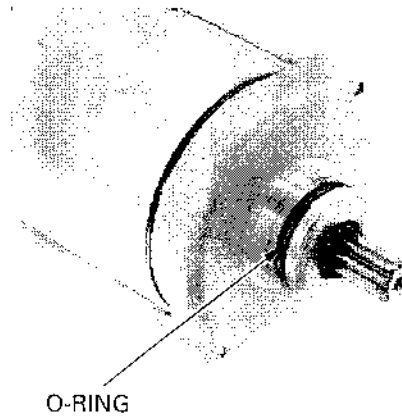

### DISASSEMBLY

*Record the location and number of shims and washers.*

Remove the bolts, rear cover and O-ring.

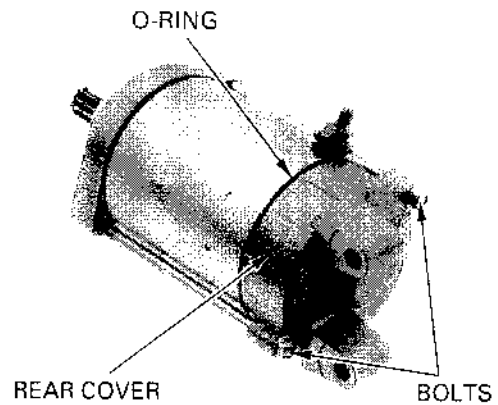

Remove the thrust washers.

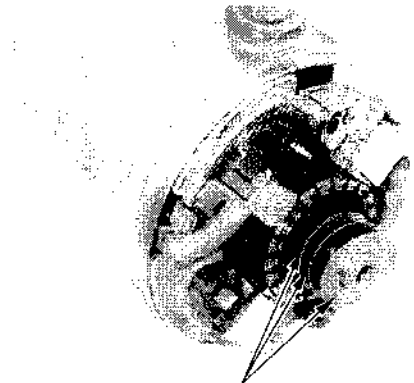

THRUST WASHERS

Remove the front cover.

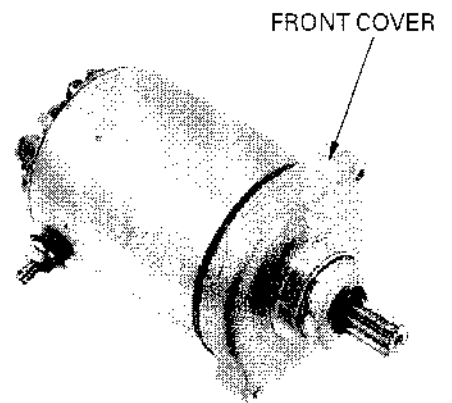

FRONT COVER

Remove the O-ring and thrust washers.

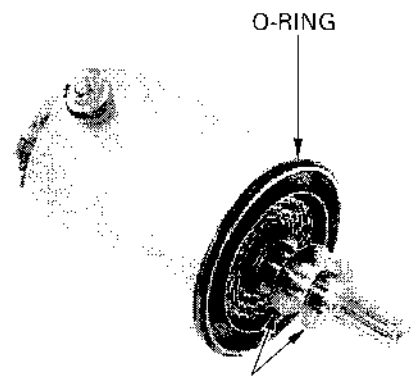

O-RING

THRUST WASHERS

Remove the armature.

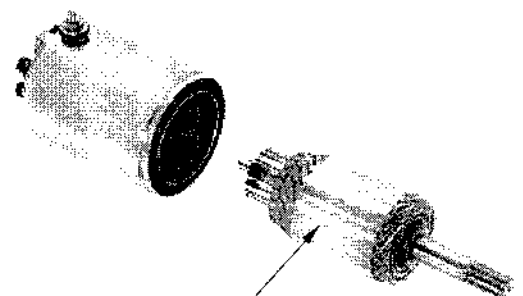

ARMATURE

# ELECTRIC STARTER

---

Remove the terminal nut.

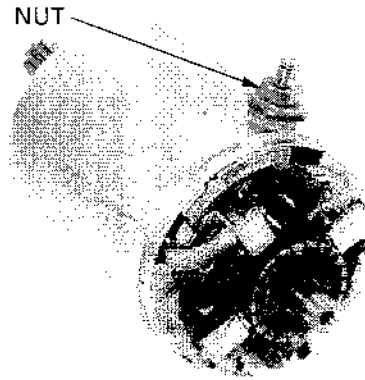

Remove the washer, shims and O-ring.

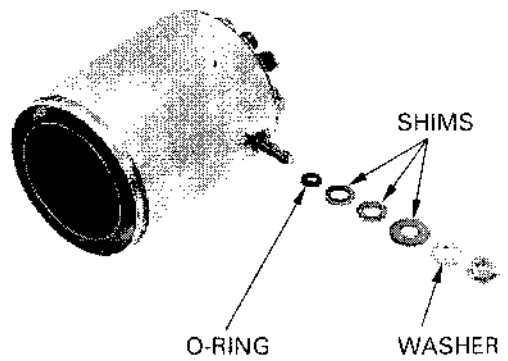

Remove the brush holder assembly.

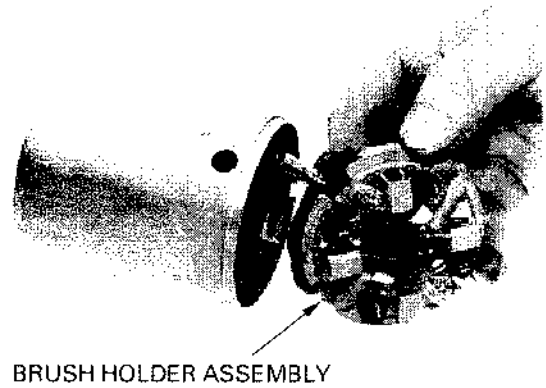

## BRUSH HOLDER DISASSEMBLY

Remove the terminal bolt stopper, terminal bolt, motor brushes and brush springs.

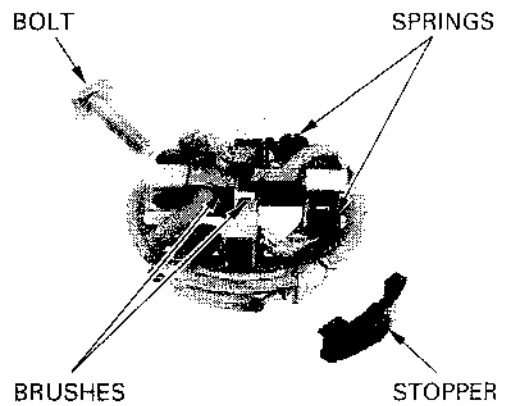

**INSPECTION**

Measure the each brush length.

**SERVICE LIMIT:** 6.5 mm (0.26 in)

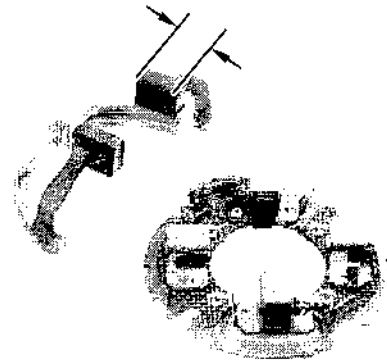

Check for continuity between starter motor terminal and positive brush.

There should be continuity.

Check for continuity between starter motor terminal and starter motor case.

There should be no continuity.

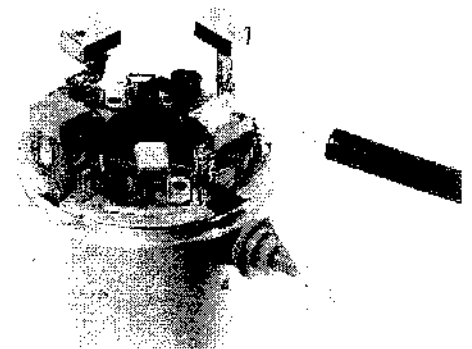

Check for continuity between positive and negative terminals.

There should be no continuity.

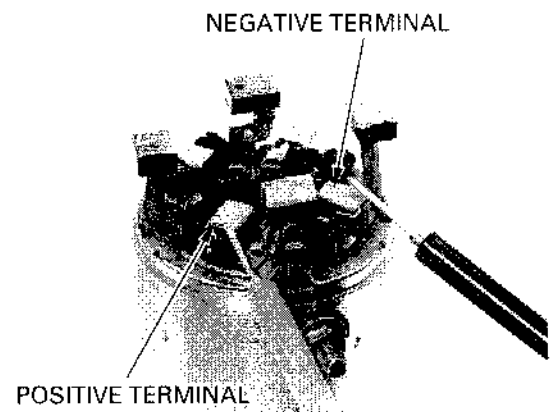

Check the commutator for damage or abnormal wear.

Replace the armature with a new one if necessary.

Check the commutator for metallic debris between commutator bars.

Clean the metallic debris off between commutator bars.

**NOTE:**

Do not use emery or sand paper on the commutator.

Check the commutator for discoloration of the commutator bar.

Replace the armature with a new one if necessary.

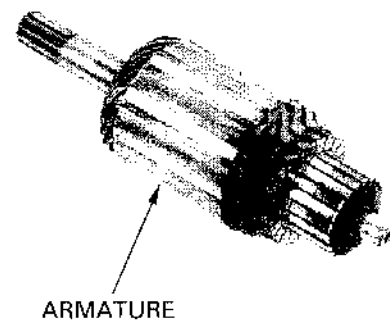

## ELECTRIC STARTER

Check for continuity between pairs of commutator bars.  
There should be continuity.  
Replace the armature with a new one if necessary.

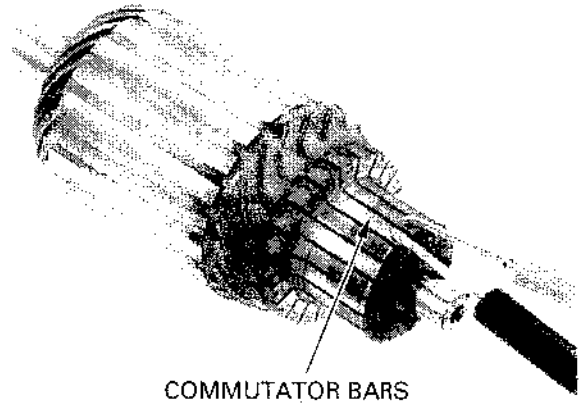

Check for continuity between each individual commutator bar and the armature shaft.  
There should be no continuity.  
Replace the armature with a new one if necessary.

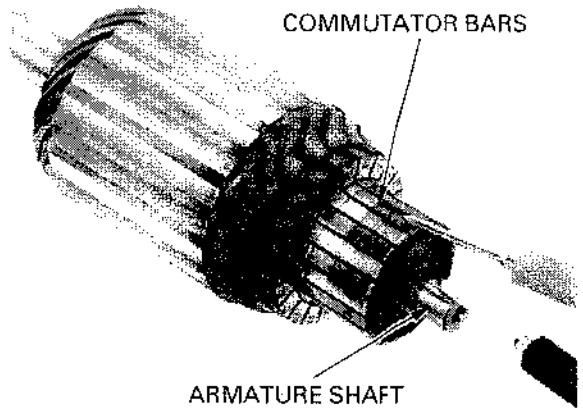

Remove the lock washer from the front cover.

Check the dust seal and needle bearing for wear or damage.  
Check the needle bearing rotates smoothly.

Apply grease to the seal lips and needle bearing.  
Install the lock washer to the front cover.

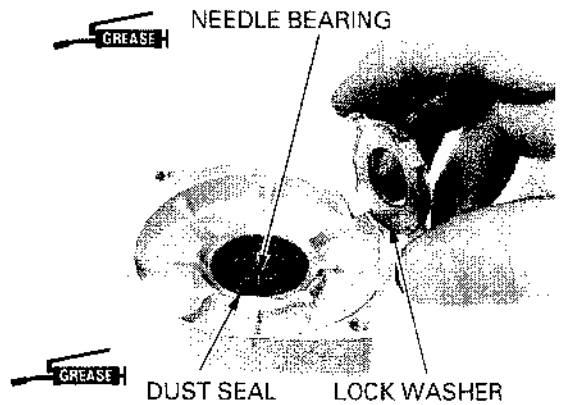

Remove the starter idle gear, reduction gear and shafts (page 9-3).

Check the starter idle gear and shaft for wear or damage.

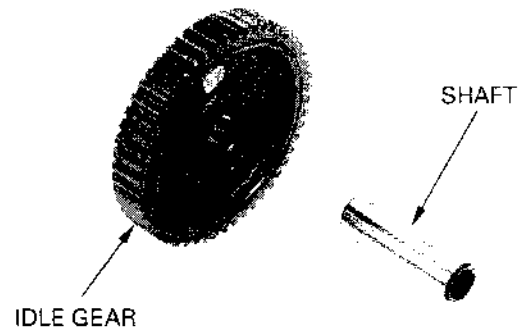

Check the starter reduction gear and shaft for wear or damage.

Install the starter idle gear, reduction gear and shafts (page 9-8).

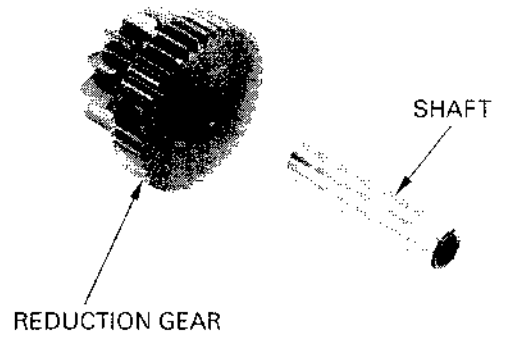

**ASSEMBLY**

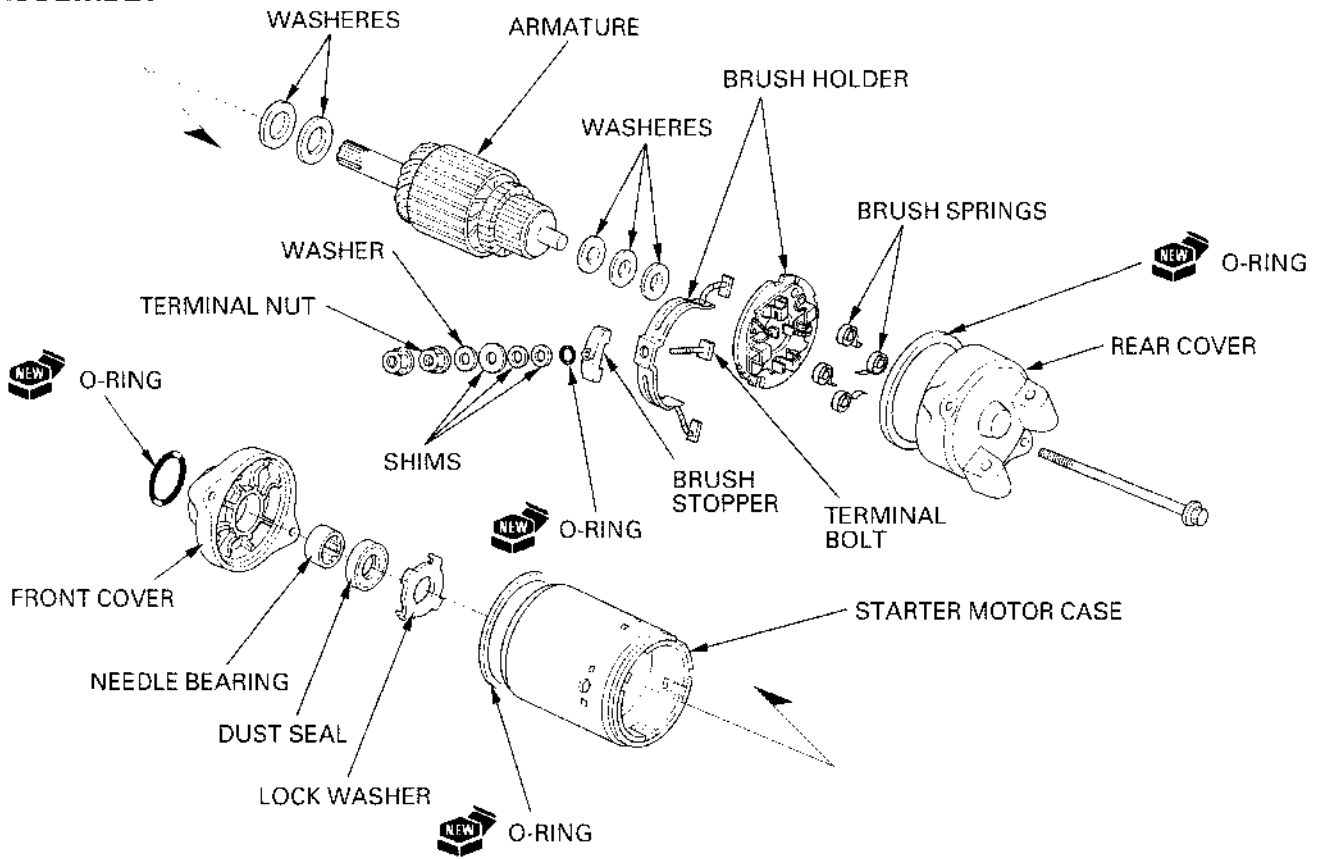

**BRUSH HOLDER ASSEMBLY**

Install the brush spring, motor brush and terminal bolt.

**NOTE:**

Set the brush spring as shown.

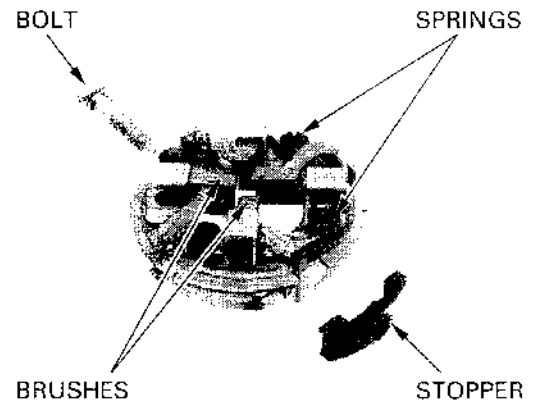

## ELECTRIC STARTER

Install the terminal bolt stopper with its tab side facing to the rear cover side.

Install the terminal bolt and brush holder to the starter motor case aligning the terminal bolt and hole on the starter motor case.

Align the starter motor case notch with the brush holder tab.

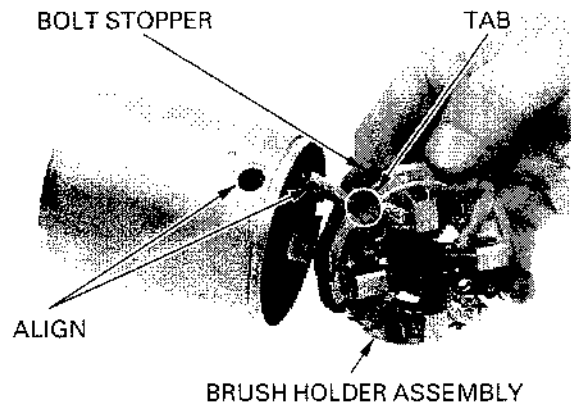

Install the new O-ring.

Install the same number of shims in the same locations as when disassembled.

Install the washer and terminal nut.

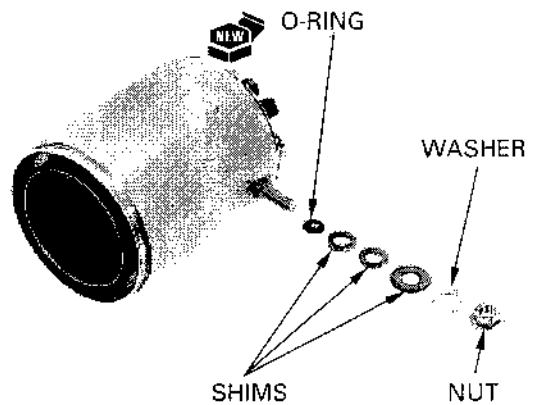

Tighten the terminal nut securely.

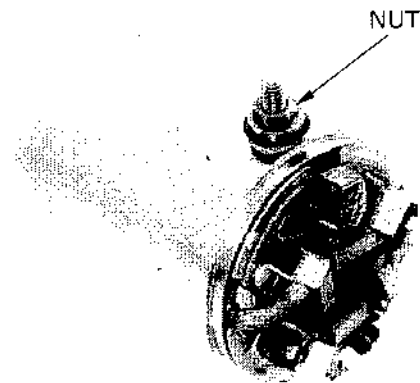

Push and hold the brush inside the brush holder, and install the armature through the brush holder.

When installing the armature into the stator motor case, hold the armature tightly to keep the magnet from pulling the armature against the stator motor case.

### CAUTION:

- *The coil may be damaged if the magnet pulls the armature against the case.*
- *The sliding surfaces of the brushes can be damaged if they are not installed properly.*

Set the brush springs.

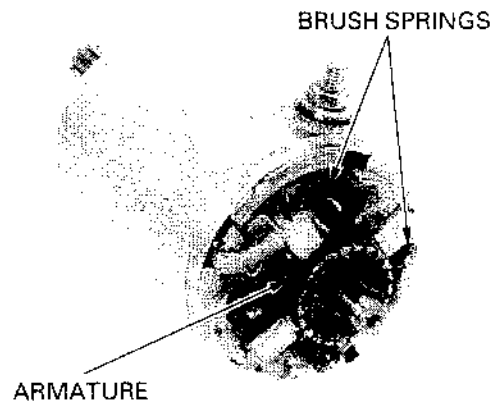



Install the new O-ring.  
Install the same number of thrust washers in the same locations as when disassembled.

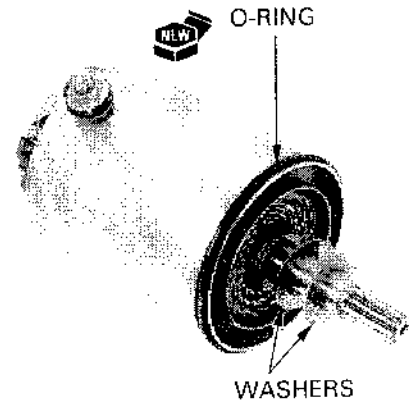

Install the front cover.

**CAUTION:**

*When installing the front cover, take care to prevent damaging the oil seal lip with the armature shaft.*

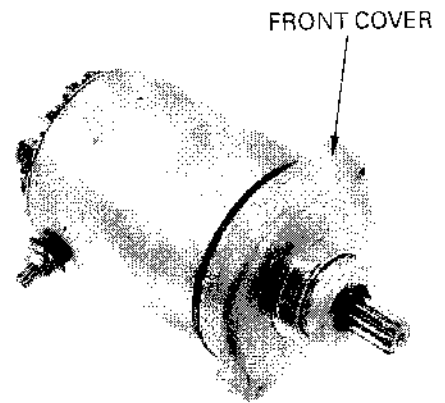

Install the same number of thrust washers in the same locations as when disassembled.

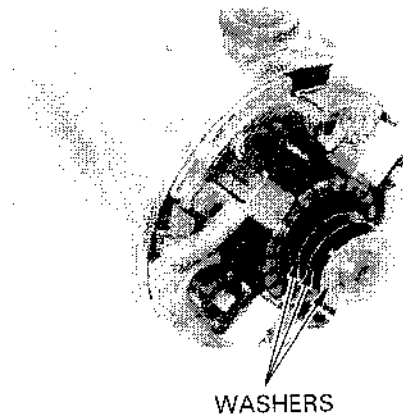

Install the new O-ring.  
Apply thin coat of grease to the armature shaft end.  
Install the rear cover aligning its groove with the brush holder tab.

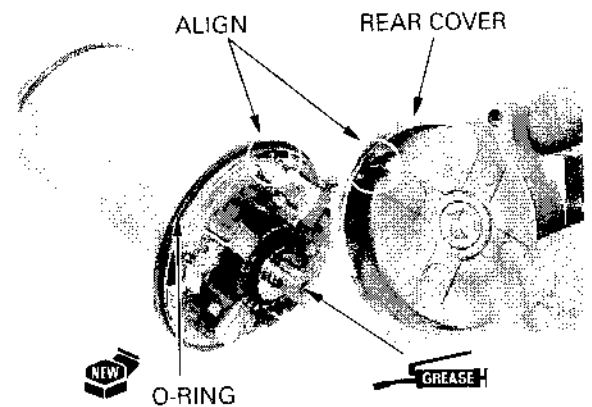

## ELECTRIC STARTER

Align the index marks on the starter motor case and front cover.

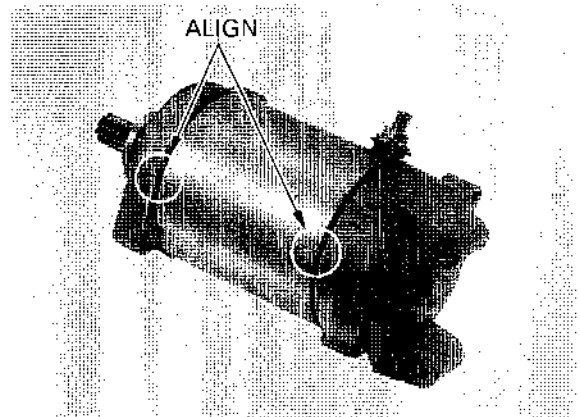

Install and tighten the bolts securely.

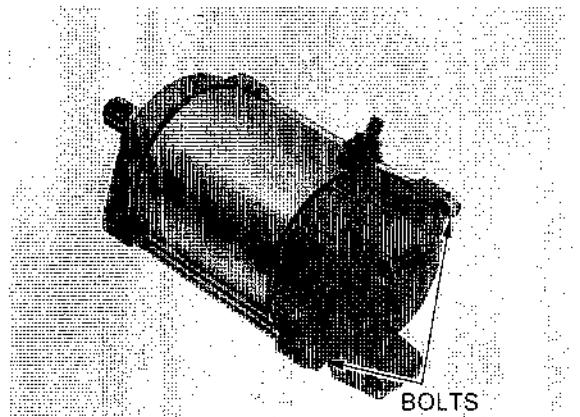

## INSTALLATION

### NOTE:

Route the starter motor cable and ground cable properly (page 1-25).

Apply oil to the new O-ring and install it to the starter motor groove.

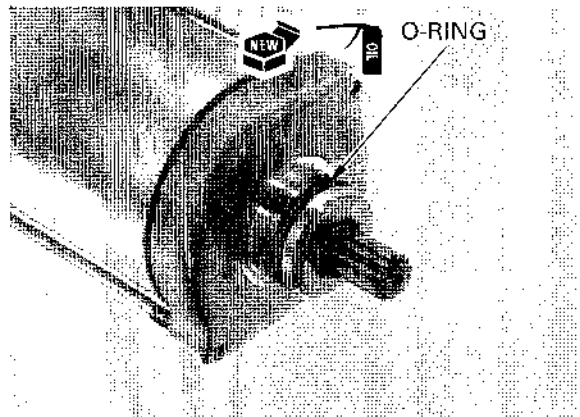

Install the starter motor onto the crankcase.  
Install the ground cable.  
Install and tighten the bolts securely.

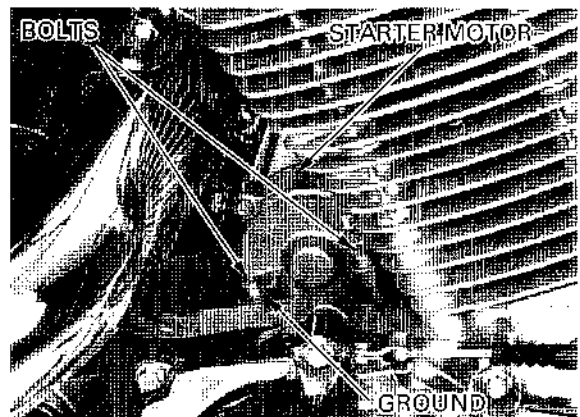

Connect the starter motor cable.  
Install and tighten the starter motor cable nut securely.

**TORQUE:** 10 N·m (1.0 kgf·m , 7 lbf·ft)

Install the rubber cap securely.

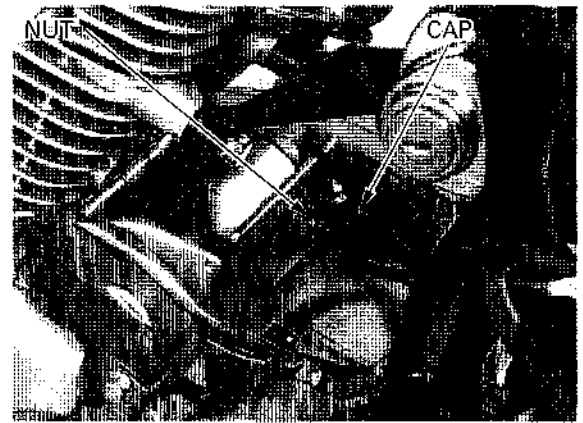

## STARTER RELAY SWITCH

### INSPECTION

**NOTE:**

Before checking the starter relay switch, check for battery condition.

Remove the right side cover (page 2-3).

Shift the transmission into neutral.  
Turn the ignition switch ON and engine stop switch to RUN.  
Depress the starter switch button.

The coil is normal if the starter relay switch clicks.

If you don't hear the switch "CLICK", inspect the relay switch using the procedure below.

### GROUND LINE

Disconnect the starter relay switch 4P connector.  
Check for continuity between the Green/Red wire (ground line) and ground.

If there is continuity when the transmission is in neutral or when the clutch is disengaged and the side stand switch is up, the ground circuit is normal (In neutral, there is a slight resistance due to the diode).

### STARTER RELAY VOLTAGE

Connect the starter relay switch 4P connector.  
Shift the transmission into neutral.  
Measure the voltage between the Yellow/Red (+) wire and ground at the starter relay switch 4P connector.

If the battery voltage appears only when the starter switch is pressed with the ignition switch ON, it is normal.

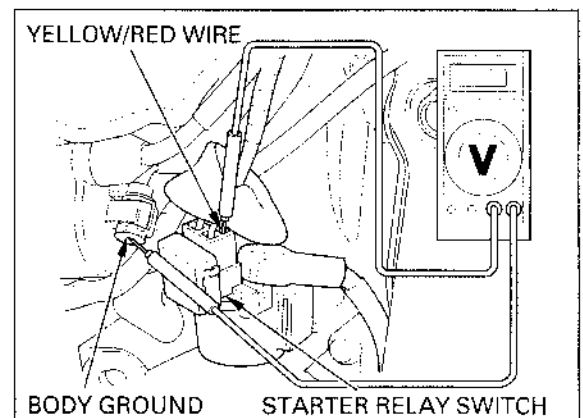
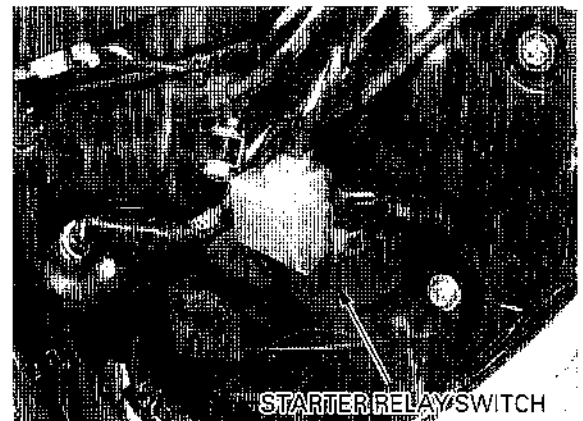

## ELECTRIC STARTER

### OPERATION CHECK

Disconnect the starter relay switch 4P connector and cables.

Connect a fully charged 12 V battery positive wire to the relay switch Yellow/Red wire terminal and negative wire to the Green/Red wire terminal.

There should be continuity between the large terminals while the battery is connected, and no continuity when the battery is disconnected.

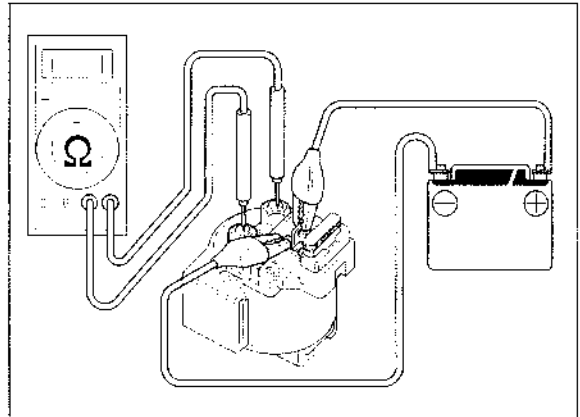

### REMOVAL/INSTALLATION

Remove the right side cover (page 2-2).

Disconnect the starter relay 4P connector.

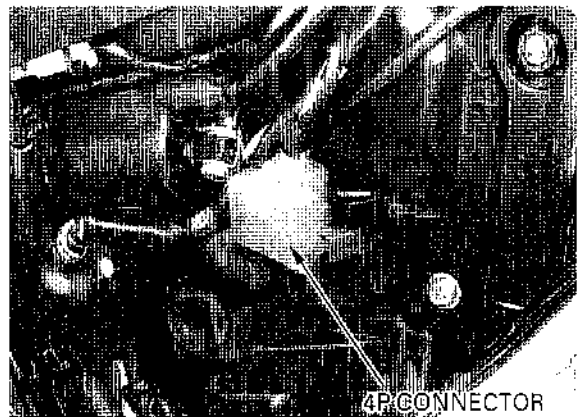

Remove the socket bolts and cables.

Remove the starter relay switch.

Installation is in the reverse order of removal.

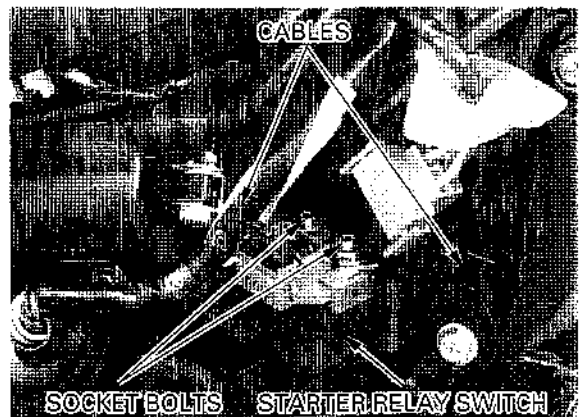

## CLUTCH DIODE

### INSPECTION

Remove the left side cover (page 2-3).

Remove the tape and diode.



Check for continuity between the diode terminals.  
When there is continuity, a small resistance value  
will register.

If there is continuity in one direction, the diode is  
normal.

DIODE

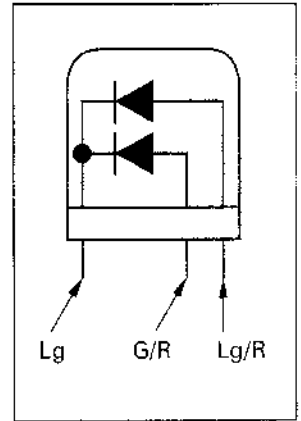

# LIGHTS/METERS/SWITCHES

'97 - '98:

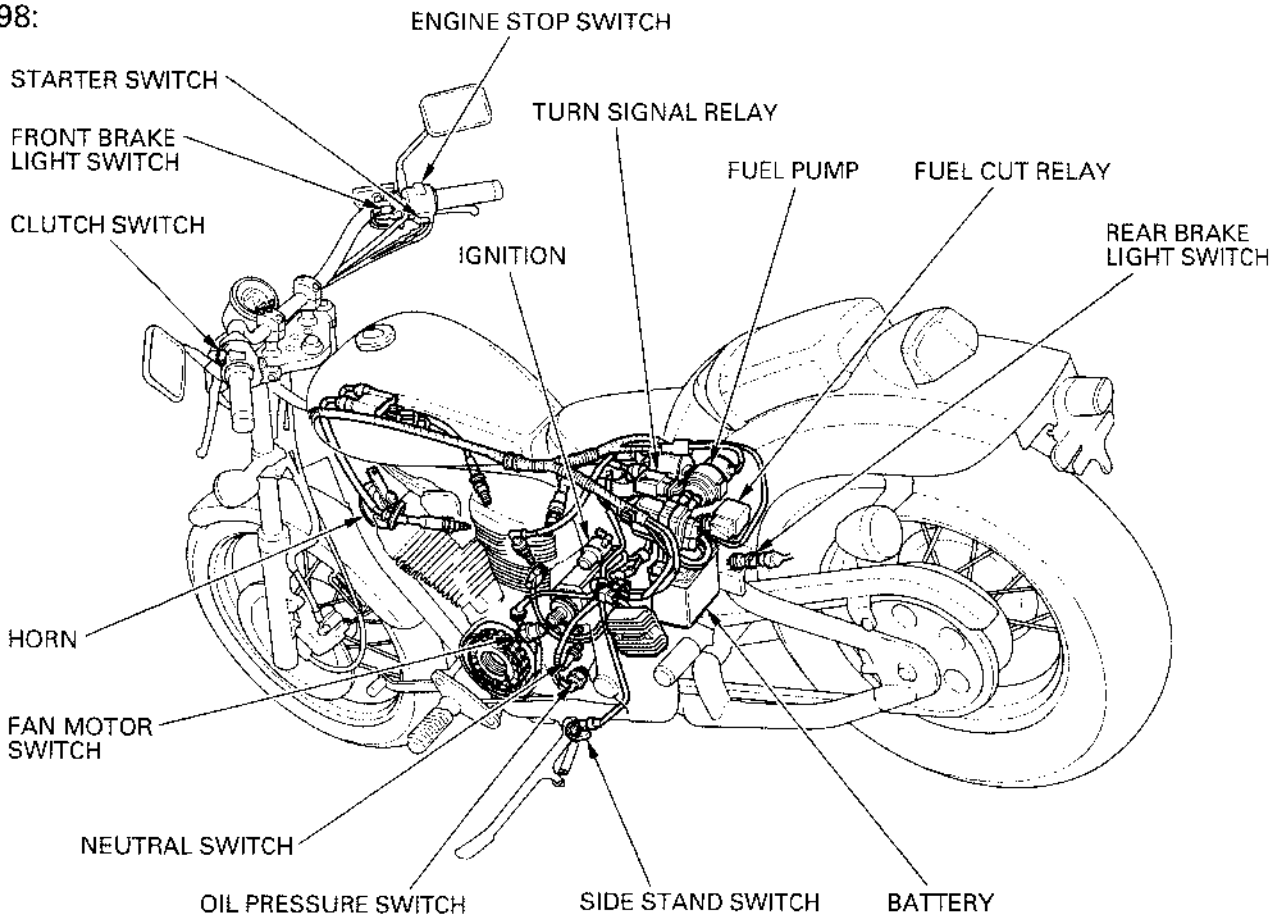

After '98:

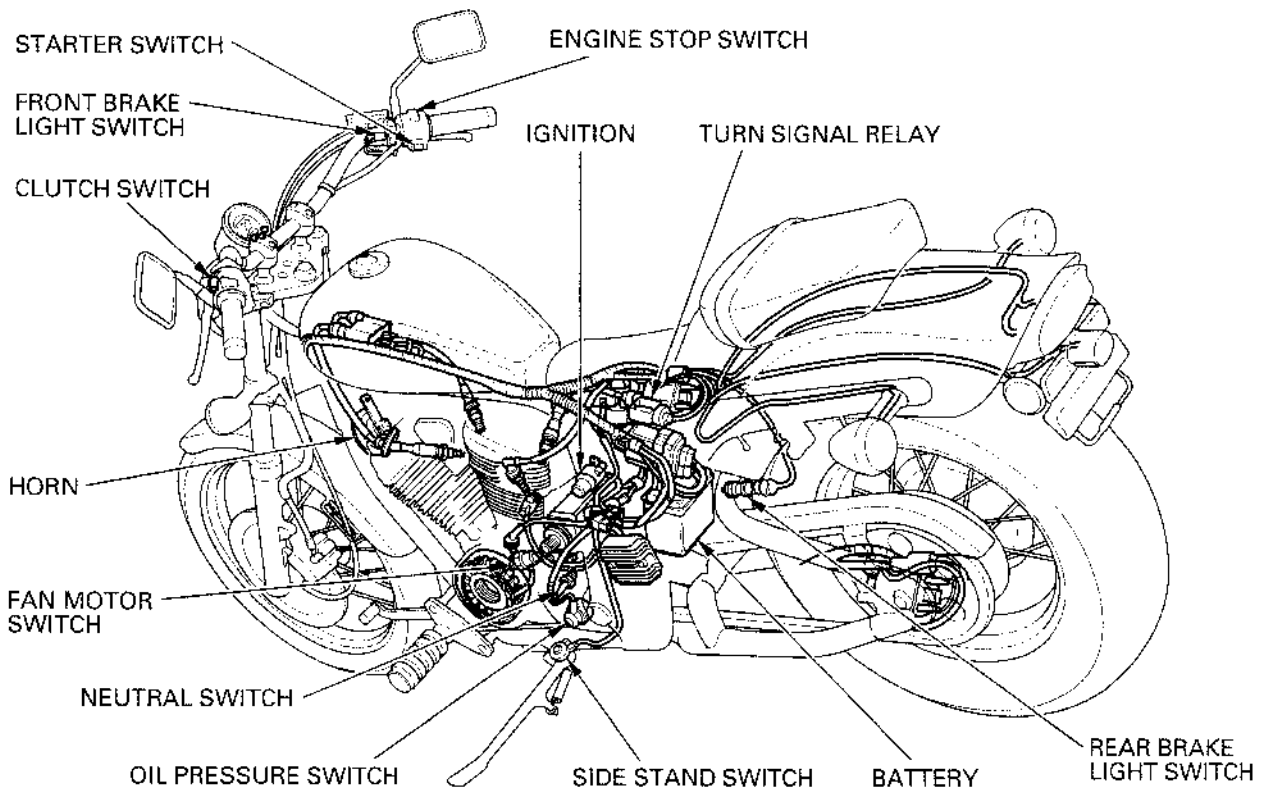

# 19. LIGHTS/METERS/SWITCHES

SYSTEM DIAGRAM	19-0	HANDLEBAR SWITCH	19-10
SERVICE INFORMATION	19-1	IGNITION SWITCH	19-11
BULB REPLACEMENT	19-3	FAN MOTOR SWITCH	19-12
SPEEDOMETER	19-6	COOLANT TEMPERATURE INDICATOR, THERMOSENSOR	19-13
OIL PRESSURE INDICATOR/SWITCH INSPECTION	19-8	HORN	19-14
NEUTRAL INDICATOR/SWITCH	19-9	TURN SIGNAL RELAY	19-15
FRONT BRAKE LIGHT SWITCH	19-9	SIDE STAND SWITCH	19-15
REAR BRAKE LIGHT SWITCH	19-10		
CLUTCH SWITCH	19-10		

## SERVICE INFORMATION

### GENERAL

#### ▲ WARNING

- *A halogen headlight bulb becomes very hot while the headlight is ON, and remains hot for a while after it is turned OFF. Be sure to let it cool down before servicing.*
- *Use an electric heating element to heat the water/coolant mixture for the thermosensor inspection. Keep all flammable materials away from the electric heating element. Wear protective clothing, insulated gloves and eye protection.*

- Note the following when replacing the halogen headlight bulb.
  - Wear clean gloves while replacing the bulb. Do not put finger prints on the headlight bulb, as they may create hot spots on the bulb and cause it to break.
  - If you touch the bulb with your bare hands, clean it with a cloth moistened with alcohol to prevent its early failure.
  - Be sure to install the dust cover after replacing the bulb.
- All plastic connectors have locking tabs that must be released before disconnecting, and must be aligned when reconnecting.
- Always turn off the ignition switch before disconnecting any electrical components.
- A continuity test can be made with switches installed on the motorcycle.
- Check the battery condition before performing any inspection that requires proper battery voltage.
- The following color codes used are indicated throughout this section.

Bu: Blue	G: Green	Lg: Light Green	R: Red
Bl: Black	Gr: Gray	O: Orange	W: White
Br: Brown	Lb: Light Blue	P: Pink	Y: Yellow

## LIGHTS/METERS/SWITCHES

ITEM		SPECIFICATIONS
Bulbs	Headlight (High/low beam)	12V-60/55W
	Brake/tail light	12V-32/3CP × 2
	Front turn signal/running light	12V-21/5W × 2
	Rear turn signal light	12V-21W × 2
	License light	12V-4CP
	Instrument light	12V-3.4W
	Turn signal indicator	12V-1.7W
	High beam indicator	12V-1.7W
	Neutral indicator	12V-1.7W
Fuse	Main fuse	30A
	Sub fuse	10A × 3, 15A × 1
Fuel pump flow capacity (min./minute)		800 cm <sup>3</sup> (27.1 US oz, 28.2 Imp oz)
Fan motor switch	Start to close (ON)	98 – 102 °C (208 – 216 °F)
	Start to open	93 – 97 °C (199 – 207 °F)
Thermosensor resistance	50 °C/122 °F	130 – 180 Ω
	80 °C/176 °F	45 – 60 Ω
	120 °C/248 °F	10 – 20 Ω

## TORQUE VALUES

Oil pressure switch	'97 – '98: 10 N·m (1.0 kgf·m, 7 lbf·ft)	Apply sealant to the threads
	After '98: 12 N·m (1.2 kgf·m, 9 lbf·ft)	
Neutral switch	12 N·m (1.2 kgf·m, 9 lbf·ft)	Apply sealant to the threads
Handlebar switch screw	4 N·m (0.4 kgf·m, 2.9 lbf·ft)	
Fan motor switch	18 N·m (1.8 kgf·m, 13 lbf·ft)	Apply sealant to the threads
Thermosensor	10 N·m (1.0 kgf·m, 7 lbf·ft)	Apply sealant to the threads
Side stand switch mounting bolt	9 N·m (0.9 kgf·m, 6.5 lbf·ft)	ALOC bolt: replace with a new one



## BULB REPLACEMENT

### HEADLIGHT

#### **▲WARNING**

*A halogen headlight bulb becomes very hot while the headlight is ON, and remain hot for a while after it is turned OFF. Be sure to let it cool down before servicing.*

#### CAUTION:

- *Wear clean gloves while replacing the bulb. Do not put finger prints on the headlight bulb, as they may create hot spots on the bulb and cause it to break.*
- *If you touch the bulb with your bare hands, clean it with a cloth moistened with alcohol to prevent its early failure.*
- *Be sure to install the dust cover after replacing the bulb.*

Remove the screws and headlight.

Disconnect the headlight bulb socket and remove the dust cover.

Unhook the bulb retainer and remove the headlight bulb.

Installation is in the reverse order of removal.

#### NOTE:

Install the dust cover with its "TOP" mark facing up.

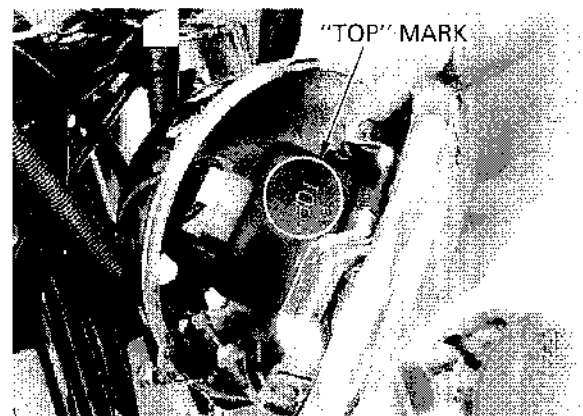
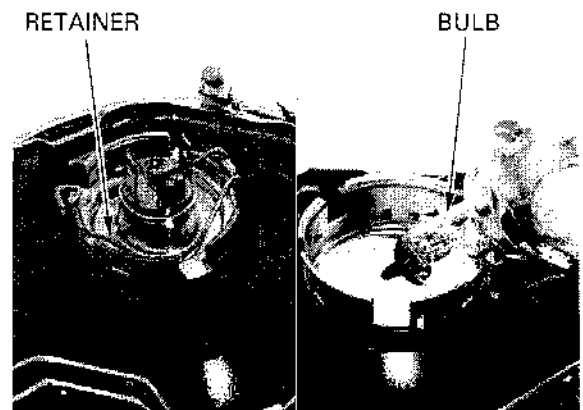
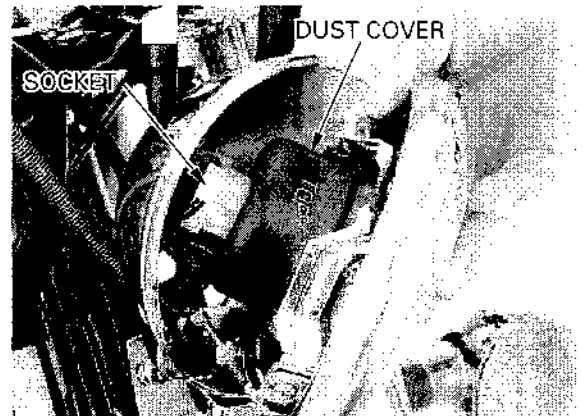
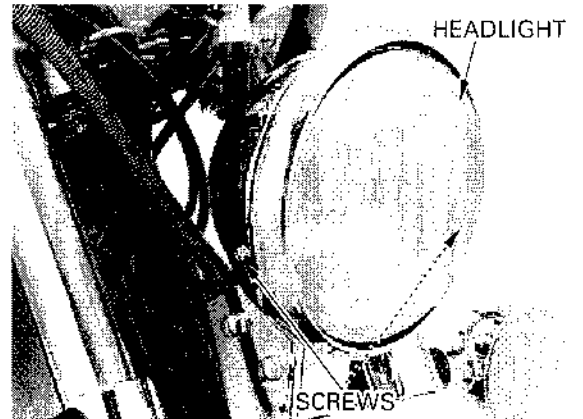

## TURN SIGNAL LIGHT

Remove the screw(s) ('97-'98) and turn signal light lens.

While pushing in, turn the bulb counterclockwise to remove it and replace with a new one.

Installation is in the reverse order of removal.

### NOTE:

- When turn signal light lens installation, align the tab on the lens with the groove on the turn signal light case.
- Seat the rubber packing properly.

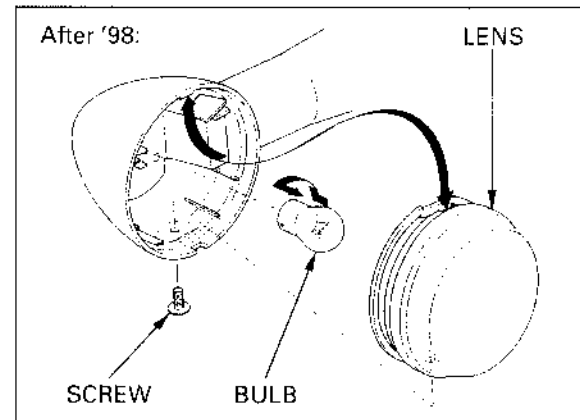
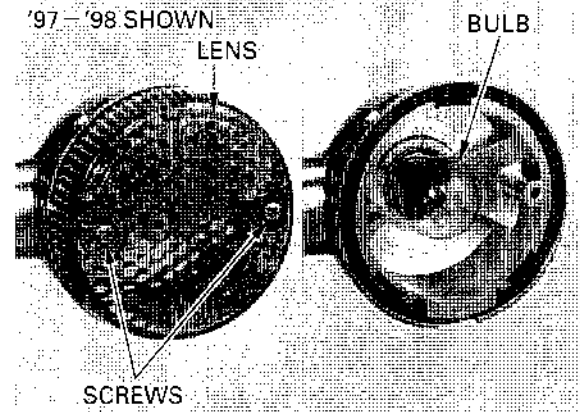

## TAIL/BRAKE LIGHT

Remove the screws and tail/brake light lens.

While pushing in, turn the bulb counterclockwise to remove it and replace with a new one.

Installation is in the reverse order of removal.

### NOTE:

Seat the rubber packing properly.

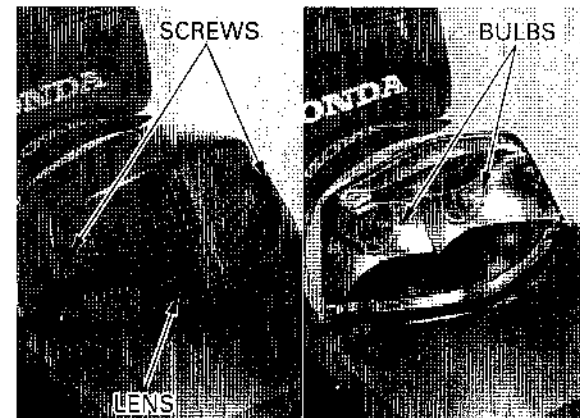

## LICENSE LIGHT

'97-'98: Remove the two bolts, three nuts and license plate bracket from the rear fender.  
*Do not damage the wire harness.*

Remove the license light lens attaching nuts on the reverse side of the license plate bracket and remove the license light lens.

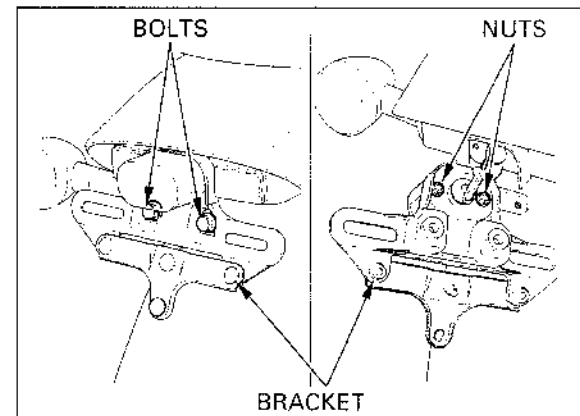

*After '98:* Remove the two screws, washers, nuts and license plate bracket from the rear fender.  
*Do not damage the wire harness.*

Remove the license light lens attaching nuts on the reverse side of the license plate bracket and remove the license light lens.

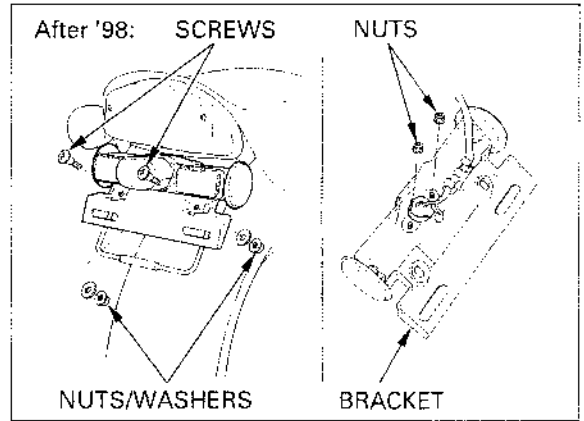

While pushing in, turn the bulb counterclockwise to remove it and replace with a new one.

Installation is in the reverse order of removal.

**NOTE:**

Seat the rubber packing properly.

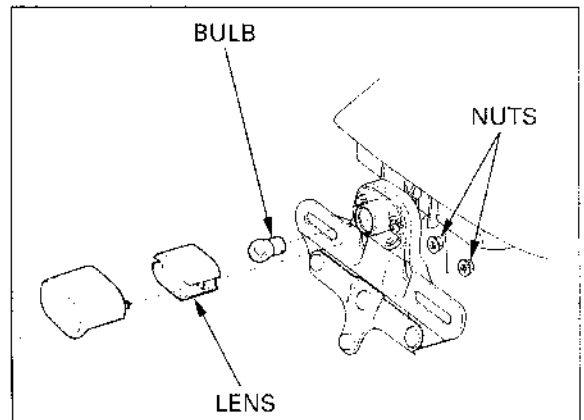

**HIBEAM/NEUTRAL/TURN INDICATOR BULB**

Remove the bulb socket from the indicator box.  
Remove the indicator bulb from the bulb socket.  
Replace a new bulb and install it in the reverse order of removal.

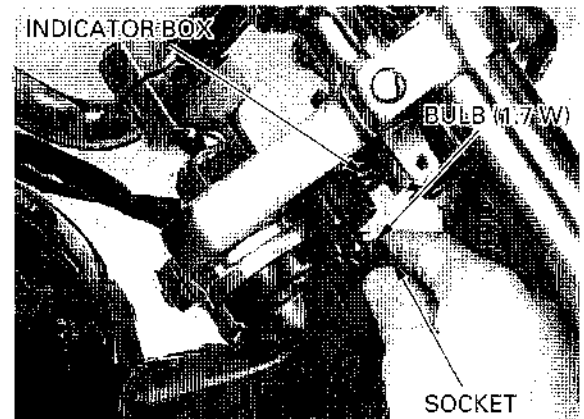

**SPEEDOMETER LIGHT**

Disconnect the speedometer cable from the speedometer.

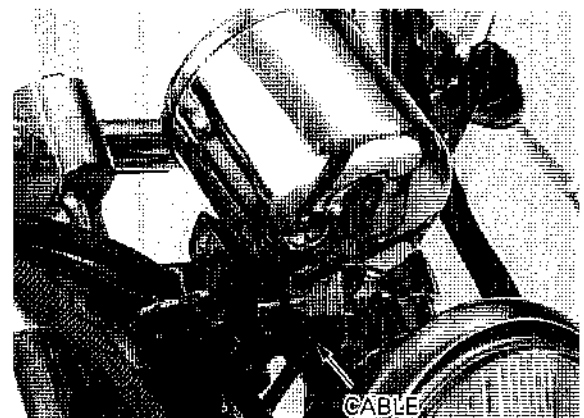

## LIGHTS/METERS/SWITCHES

Remove the speedometer cover mounting screws and cover.

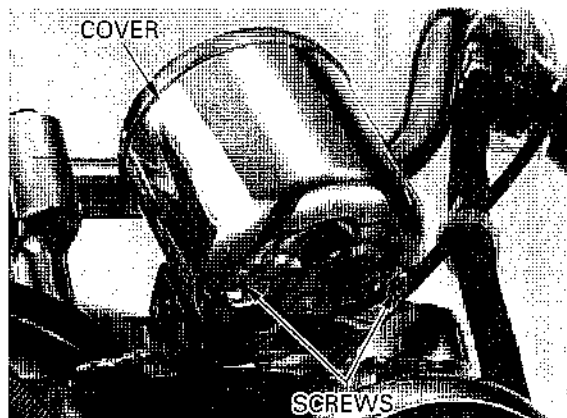

Remove the bulb socket from the speedometer.  
Remove the speedometer bulb from the bulb socket.  
Replace a new bulb and install it in the reverse order of removal.

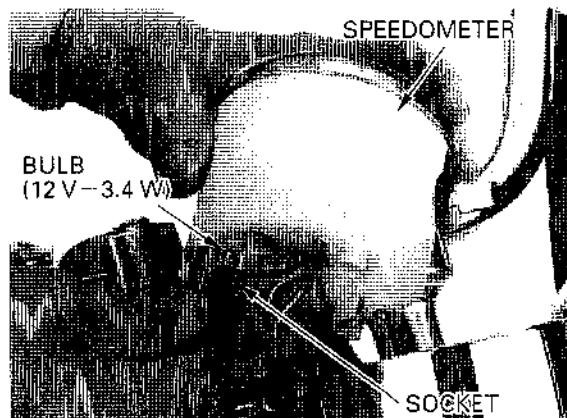

## SPEEDOMETER

### REMOVAL/INSTALLATION

Remove the steering covers (page 2-2).  
Disconnect the speedometer 6P (Black) connector.

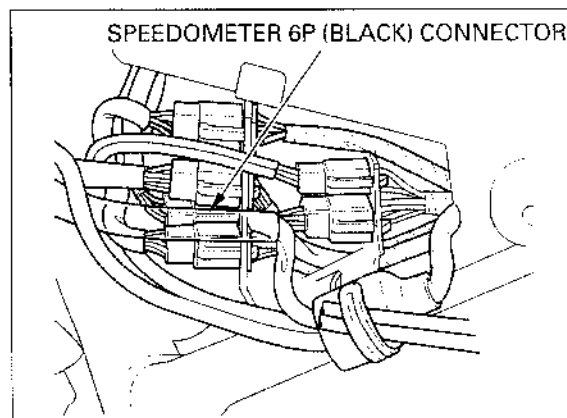

Disconnect the speedometer cable from the speedometer.

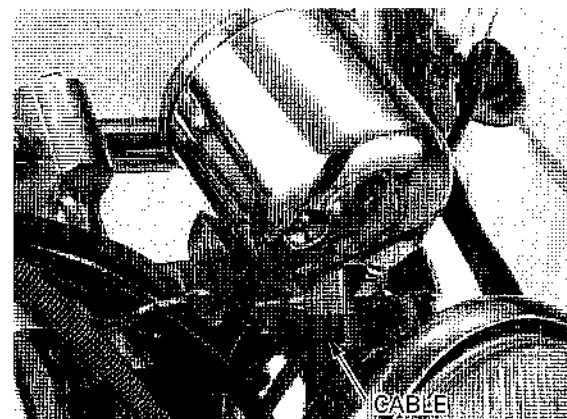

Remove the speedometer mounting nut/bolt and meter from the speedometer stay.

Installation is in the reverse order of removal.

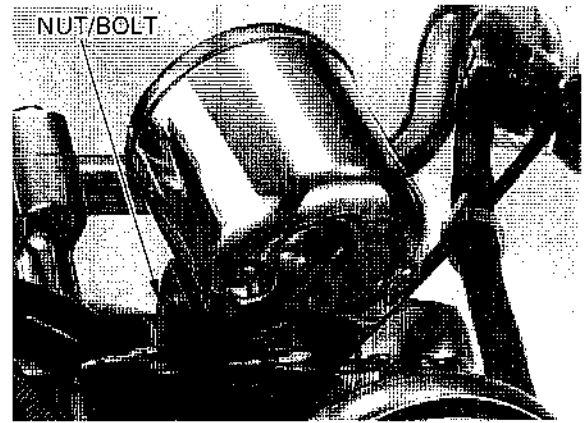

### DISASSEMBLY

Remove the speedometer (see above).

Remove the screws and speedometer rear cover.  
Remove the speedometer stay.

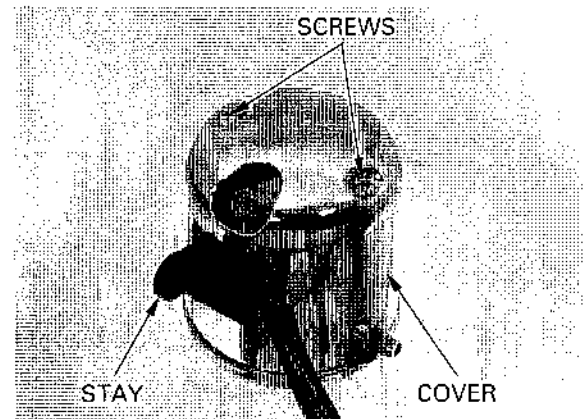

Remove the clamp and speedometer light from the speedometer.  
Remove the wire harness from the speedometer.

### ASSEMBLY

Assembly is in the reverse order of disassembly.

#### NOTE:

Route the combination meter harness properly (see below).

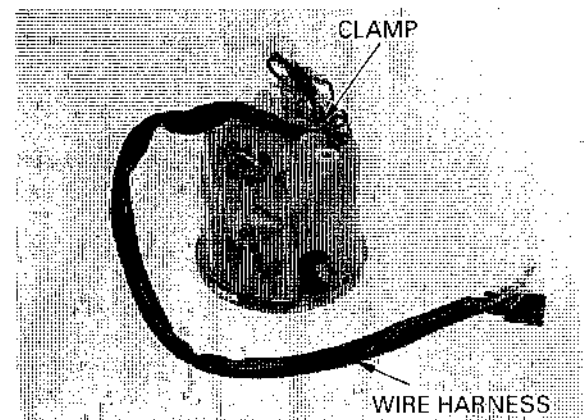

'97-'00 **NEW**

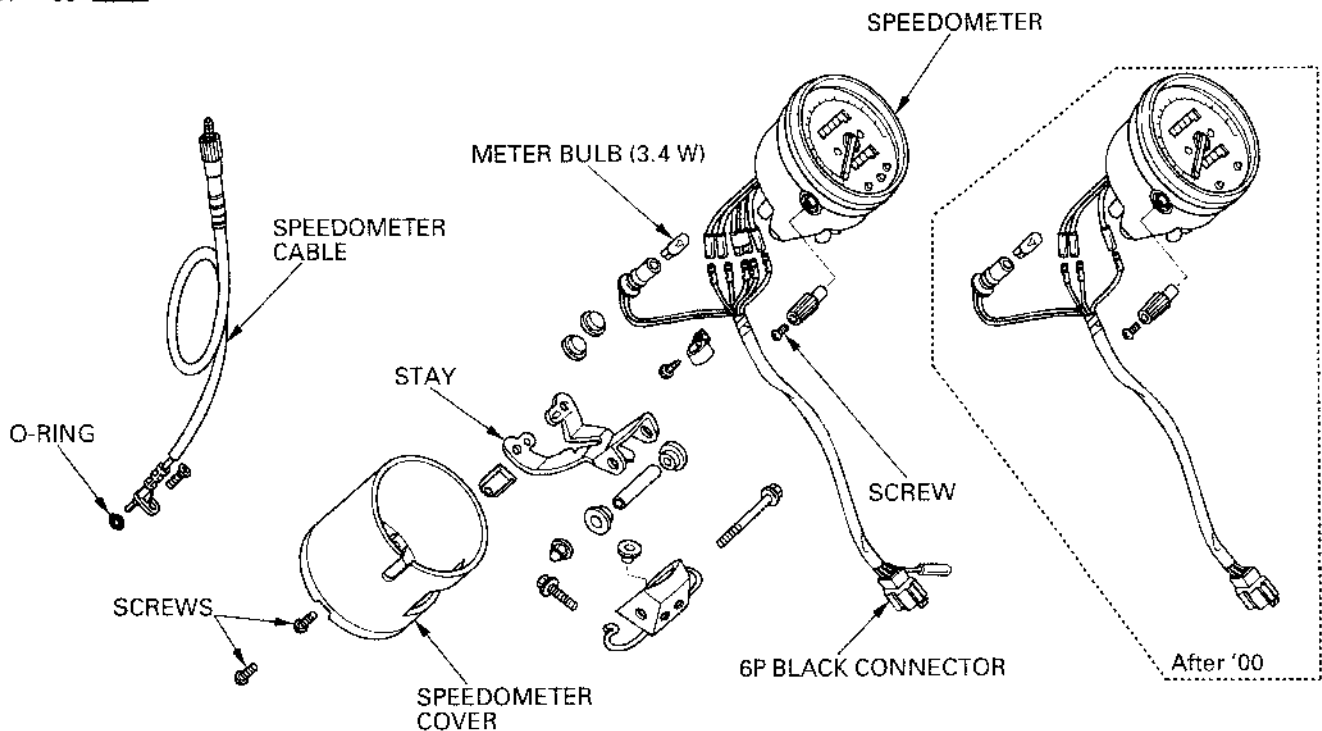

## OIL PRESSURE INDICATOR/SWITCH

### INSPECTION

**NOTE:**

**NEW** The oil pressure switch removal/installation is on page 4-3.

Make sure that the oil pressure warning indicator comes on with the ignition switch "ON".

If the indicator does not come on, inspect as follows:

Remove the left rear cover (page 7-3).  
 Disconnect the oil pressure switch wire from the switch by removing the terminal screw.  
 Short it to ground using a jumper wire. Turn the ignition switch "ON".

The oil pressure warning indicator should come on. If the indicator does not come on, check the sub-fuse (10 A) and wires for a loose connection or an open circuit.

Start the engine and make sure that the indicator goes out. If the indicator does not go out, check the oil pressure (page 4-3).  
 If the oil pressure is normal, replace the oil pressure switch (page 7-3).

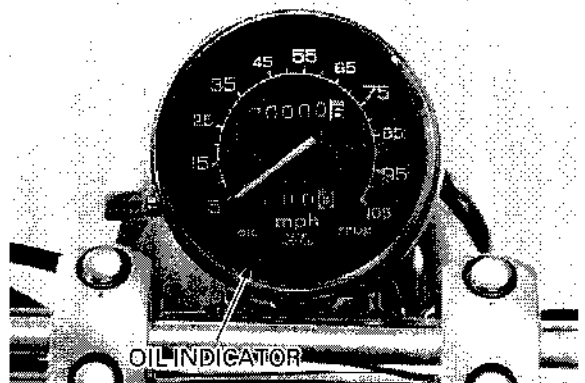

## NEUTRAL INDICATOR/SWITCH

### INSPECTION

Make sure that the neutral indicator comes on with the ignition switch "ON" and neutral position. If the indicator does not come on, inspect as follows:

Remove the left rear cover (page 7-3).  
Disconnect the neutral switch connector.

Short it to ground using a jumper wire. Turn the ignition switch "ON".

The neutral indicator should come on. If the indicator does not come on, check the sub fuse (10 A) and wires for a loose connection or an open circuit.

### REMOVAL/INSTALLATION

Remove the left rear cover (page 7-3).

Disconnect the neutral switch connector.

Remove the neutral switch.

Clean and apply sealant to the neutral switch threads.

Install and tighten the neutral switch to the specified torque.

**TORQUE:** 12 N·m (1.2 kgf·m, 9 lbf·ft)

Connect the neutral switch connector.

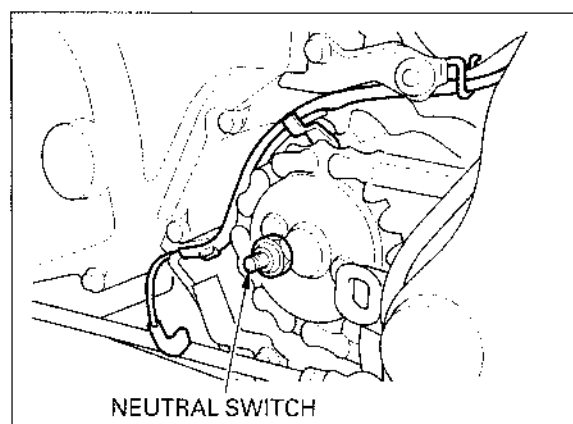
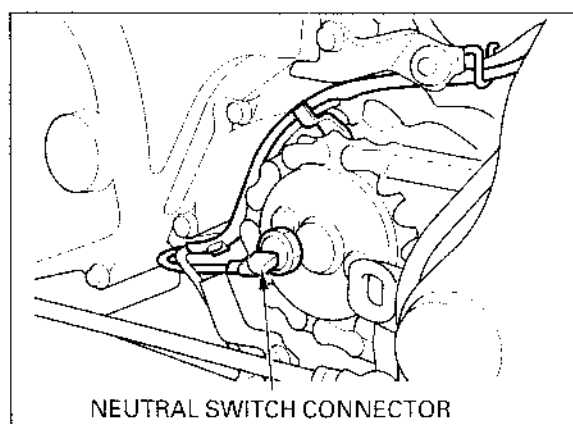

## FRONT BRAKE LIGHT SWITCH

### NOTE:

For front brake light switch removal/installation refer to page 15-8.

Disconnect the front brake light switch connectors and check for continuity.

There should be continuity with the front brake applied and no continuity with it released.

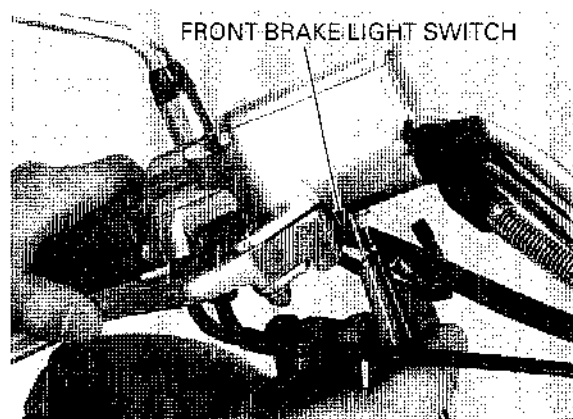

## REAR BRAKE LIGHT SWITCH

Remove the right side cover (page 2-3).

Disconnect the rear brake light switch 2P connector and check for continuity at the switch side connector.

There should be continuity with the rear brake applied and no continuity with it released.

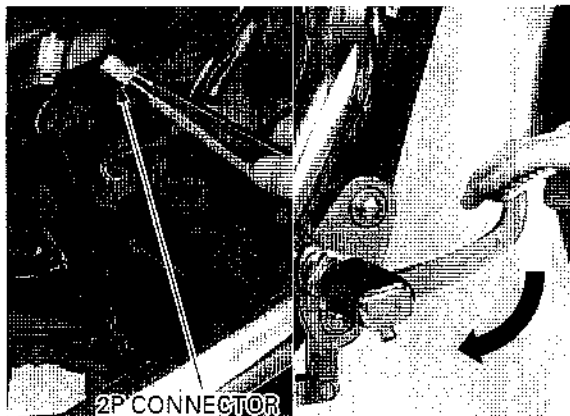

## CLUTCH SWITCH

NOTE:

For clutch switch removal/installation refer to page 13-5.

Disconnect the clutch switch connectors and check for continuity.

There should be continuity with the clutch applied and no continuity with it released.

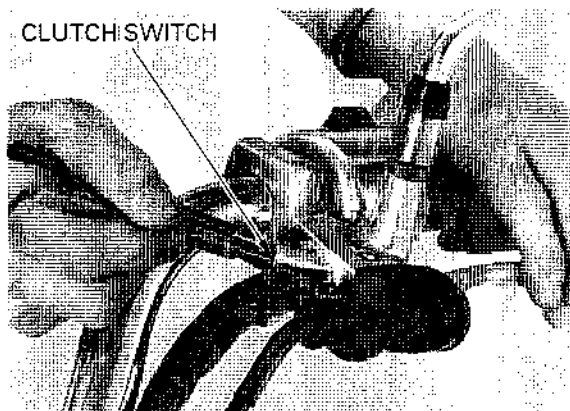

## HANDLEBAR SWITCH

NOTE:

For handlebar switches removal/installation refer to page 13-5.

Remove the left steering cover (page 2-3).

Check for continuity between the terminals. Continuity should exist between the color coded wires as shown in each chart.

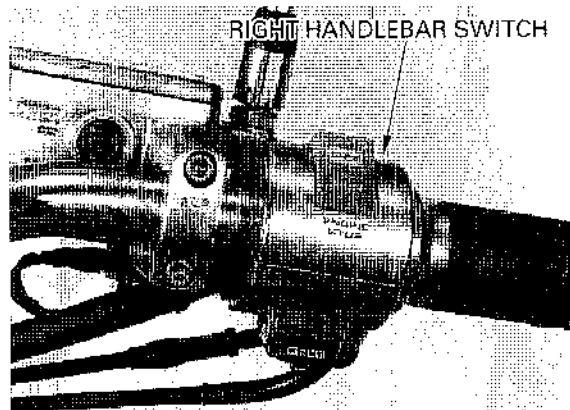

### RIGHT HANDLEBAR SWITCH

Disconnect the right handlebar switch 9P connector.

#### STARTER SWITCH

	BI/W	Y/R
Free		
Push	○	○

#### ENGINE STOP SWITCH

	BI/G	BI/W
Off		
Run	○	○

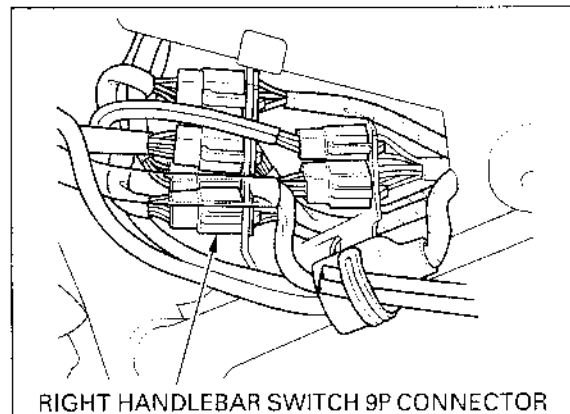



**LEFT HANDLEBAR SWITCH**

Disconnect the left handlebar 9P switch connector.

**DIMMER SWITCH**

	Bu/W	Bu	W
Lo	<input type="checkbox"/>		<input type="checkbox"/>
(N)	<input type="checkbox"/>	<input type="checkbox"/>	<input type="checkbox"/>
Hi	<input type="checkbox"/>	<input type="checkbox"/>	

**TURN SIGNAL SWITCH**

	Gr	Lb	O	Br/Bl	Lb/W	O/W
Right	<input type="checkbox"/>	<input type="checkbox"/>		<input type="checkbox"/>		<input type="checkbox"/>
N				<input type="checkbox"/>	<input type="checkbox"/>	<input type="checkbox"/>
Left	<input type="checkbox"/>		<input type="checkbox"/>	<input type="checkbox"/>	<input type="checkbox"/>	

**HORN SWITCH**

	Bl/Br	Lg
Free		
Push	<input type="checkbox"/>	<input type="checkbox"/>

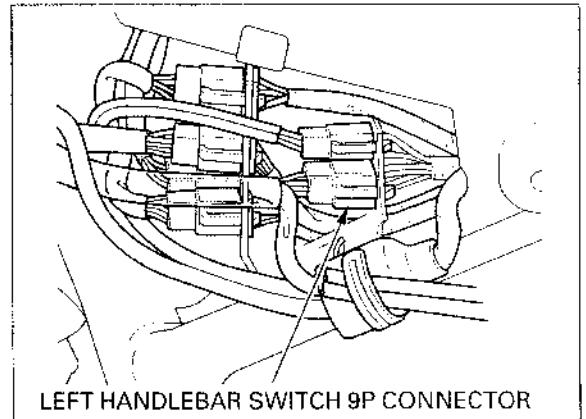
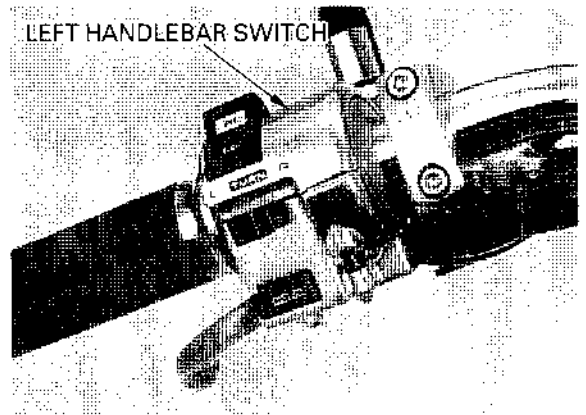

**IGNITION SWITCH**

Remove the left side cover (page 2-3).  
Disconnect the ignition switch 4P (White) connector.

Check for continuity between the ignition switch connector terminals in each switch position.

Continuity should exist between the color coded wires in each chart below.

**IGNITION SWITCH**

	R	R/Bl	Bu/O
On	<input type="checkbox"/>	<input type="checkbox"/>	<input type="checkbox"/>
Off			

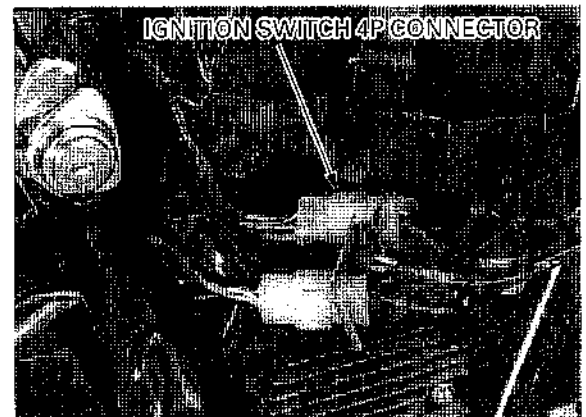

**REPLACEMENT**

Remove the ignition switch cover by removing the screw.

Remove the break-off bolt heads using a drill then remove the ignition switch.

Install the new switch and new break-off bolts. Tighten the break-off bolts until the heads twist off.

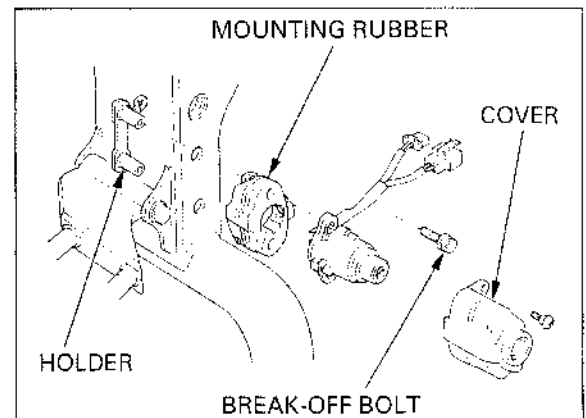

## FAN MOTOR SWITCH

### INSPECTION

#### FAN MOTOR DOES NOT STOP

Turn the ignition switch OFF, disconnect the fan motor switch connector from the fan motor switch and turn the ignition switch ON again.

If the fan motor does not stop, check for a shorted wire between the fan motor and switch.  
If the fan motor stops, replace the fan motor switch.

#### FAN MOTOR DOES NOT START

Before testing, warm up the engine to operating temperature.

Disconnect the connector from the fan motor switch and ground the connector to the body with a jumper wire.

Turn the ignition switch ON and check the fan motor.

If the motor starts, check the connection at the fan motor switch terminal. If it is OK, replace the fan motor switch.

If the motor does not start, check for voltage between the fan motor switch connector and ground.

Battery voltage: Faulty fan motor

- No battery voltage:
  - Broken wire harness
  - Broken sub fuse
  - Faulty ignition switch
  - Poor connection of the connector (between the ignition switch and fuse box)

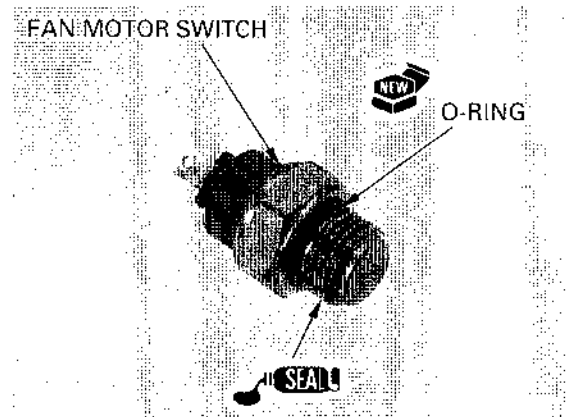
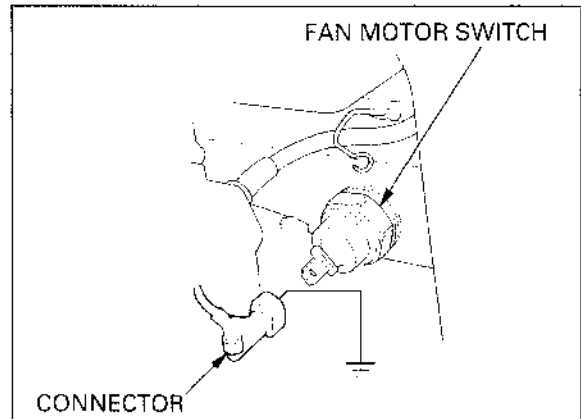
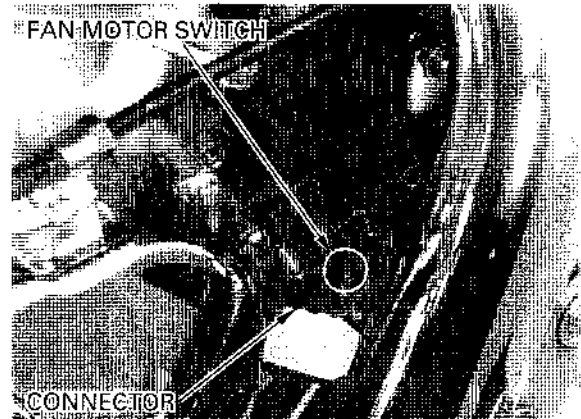

### REMOVAL/INSTALLATION

Drain the coolant (page 6-5).

Disconnect the fan motor switch connector from the fan motor switch.

Remove the fan motor switch and O-ring from the right radiator.

Install the new O-ring.

Clean and apply sealant to the fan motor switch threads.

Install and tighten the fan motor switch to the specified torque.

**TORQUE:** 18 N·m (1.8 kgf·m , 13 lbf·ft)

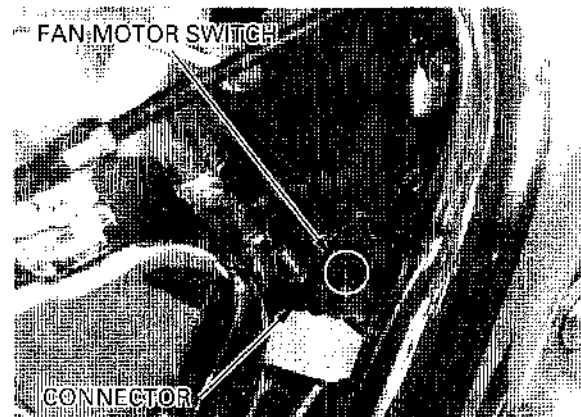

## COOLANT TEMPERATURE INDICATOR ('97-'00), THERMOSENSOR ('97-'00)/THERMO SWITCH (After '00)

### SYSTEM INSPECTION ('97-'00)

Turn the ignition switch ON. The temperature warning light should come on for a few seconds and the light should disappear soon.

#### THE INDICATOR DOES NOT COME ON

Remove the left steering cover (page 2-3).

Disconnect the thermo unit Black/Brown (+) and Green/Black (-) connectors.

Measure the voltage between the Black/Brown (+) and Green/Black (-) connectors of the wire harness side.

There should be voltage with the ignition switch ON. If there is no voltage, check the wire harness for an open circuit or loose connections in the Black/Brown (+) and Green/Black (-) wires.

If there is battery voltage available, replace the speedometer.

#### THE INDICATOR DOES NOT GO OFF

Remove the left steering cover (page 2-3).

Disconnect the temperature warning light Green/Blue connector.

Check for continuity between the Green/Blue connector of the wire harness side and ground.

There should be no continuity.

If there is continuity, check for a short circuit in the Green/Blue wire.

If there is no continuity, check the thermosensor (see the following). If it is OK, replace the speedometer.

### SYSTEM INSPECTION (After '00)

Turn the ignition switch ON, the temperature warning light should not come on.

If the warning light comes on, check the wire harness for an open circuit or loose connection between the temperature warning light and thermo switch and also check the thermo switch (Page 19-14).

### THERMOSENSOR ('97-'00)/THERMO SWITCH (After '00) INSPECTION

#### ▲WARNING

- Wear insulated gloves and adequate eye protection.
- Keep flammable materials away from the electric heating element.

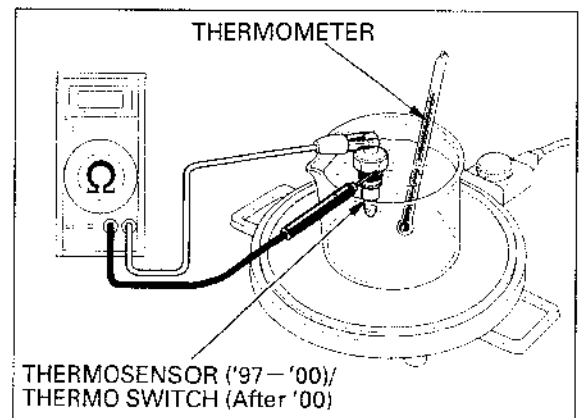
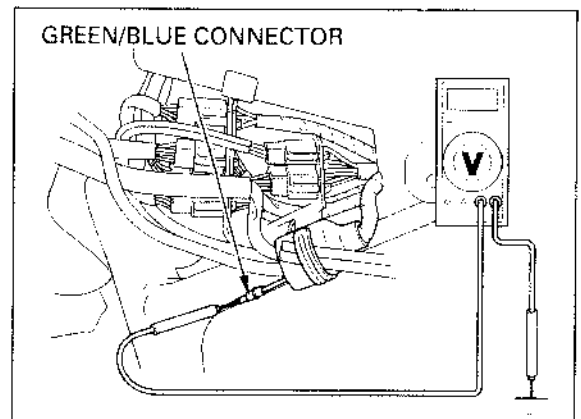
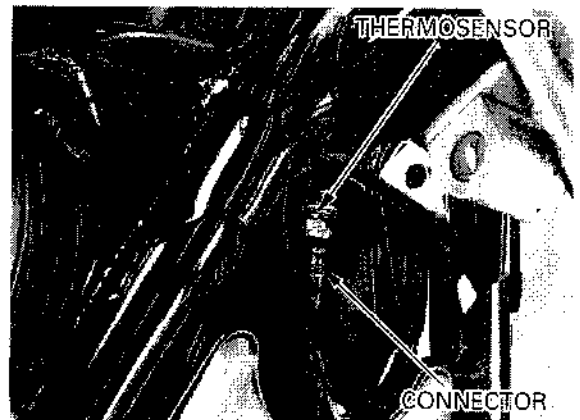
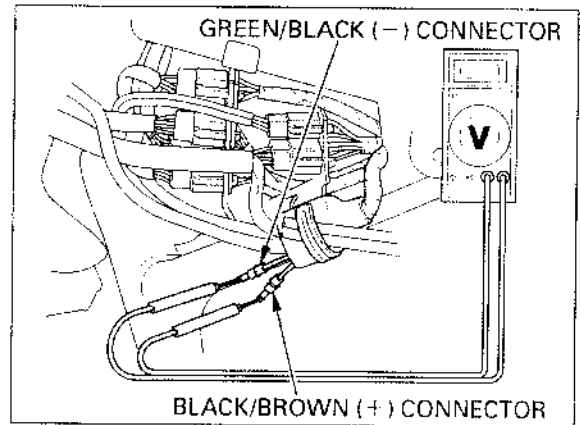

**NOTE:**

- Soak the thermosensor ('97-'00)/ thermo switch (After '00) in coolant up to its threads with at least a 40 mm (1.57 in) gap from the bottom of the pan to the bottom of the sensor/switch.
- Keep the temperature constant for 3 minutes before testing. A sudden change of temperature will result in incorrect readings. Do not let the thermosensor ('97-'00)/ thermo switch (After '00) or thermometer touch the pan.

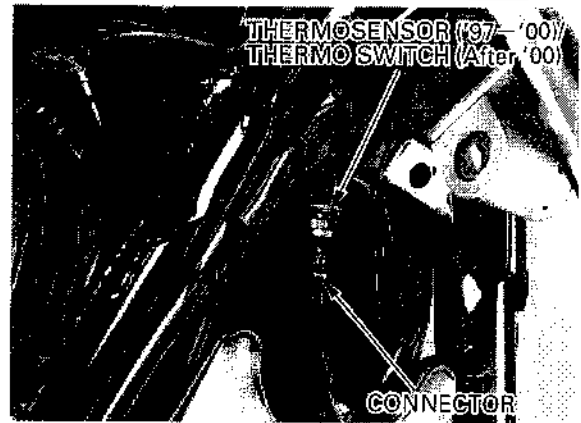

Drain the coolant (page 6-6).  
 Remove the left steering cover (page 2-3).  
 Disconnect the thermosensor ('97-'00)/ thermo switch (After '00) connector and remove the sensor/switch.  
 Suspend the thermosensor ('97-'00)/ thermo switch (After '00) in a pan of coolant (50-50 mixture) over the electric heating element and measure the resistance ('97-'00)/check the continuity (After '00) through the sensor as the coolant heats up.

**'97-'00:**

Temperature	Resistance
50 °C/122 °F	130 - 180 Ω
80 °C/176 °F	45 - 60 Ω
120 °C/248 °F	10 - 20 Ω

**After '00**

Start to close (ON)	112 - 118°C (259 - 270°F)
Start to open (OFF)	Below 108°C (252°F)

Replace the sensor ('97-'00)/ switch (After '00) if it is out of specifications.  
 Clean and apply sealant to the thermosensor ('97-'00)/ thermo switch (After '00) threads. Do not apply sealant to the thermosensor ('97-'00)/ thermo switch (After '00) head.  
 Install and tighten the thermosensor ('97-'00)/ thermo switch (After '00) to the specified torque.

**TORQUE: '97-'00:** 10 N·m (1.0 kgf·m , 7 lbf·ft)  
**After '00:** 8 N·m (0.8 kgf·m , 5.8 lbf·ft)

Connect the thermosensor ('97-'00)/ thermo switch (After '00) connector.  
 Refill the coolant (page 6-6).  
 Install the left steering cover (page 2-3).

NEW

**HORN**

Remove the steering covers (page 2-3).  
 Remove the nut.  
 Disconnect the horn connectors and remove the horn.  
 Connect a 12 V battery to the horn terminals.  
 The horn is normal if it sounds when the 12 V battery is connected across the horn terminals.

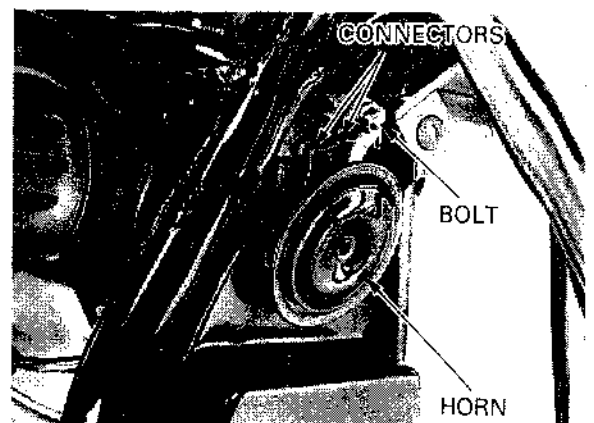

# TURN SIGNAL RELAY

## REMOVAL/INSTALLATION

Remove the seat (page 2-2).  
 Disconnect the turn signal relay 3P (Black) connector.  
 Remove the turn signal relay.

Installation is in the reverse order of removal.

## PERFORMANCE TEST

Remove the turn signal relay.  
 Check for turn signal circuit connection before testing.  
 Short the black and gray terminals of the turn signal relay connector with a jumper wire. Turn the ignition switch ON and check turn signal light by turning the switch ON.

If the light does not come on, check the turn signal switch or open circuit in Black or Gray wire.

If the light comes on, check for continuity between Green terminal and body ground at the turn signal relay 3P (Black) connector.

- No continuity: Open circuit in Green wire
- Continuity:
  - Loose or poor contact of the turn signal relay 3P (Black) connector
  - Faulty turn signal relay

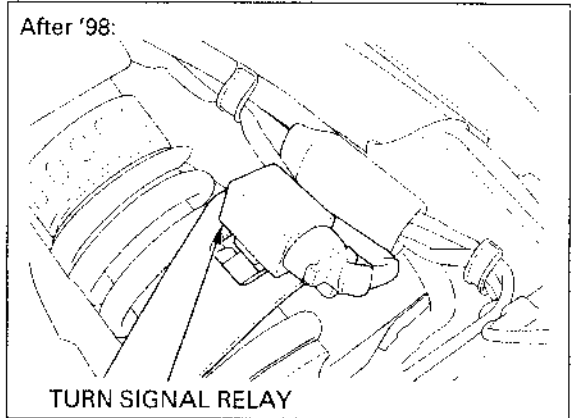
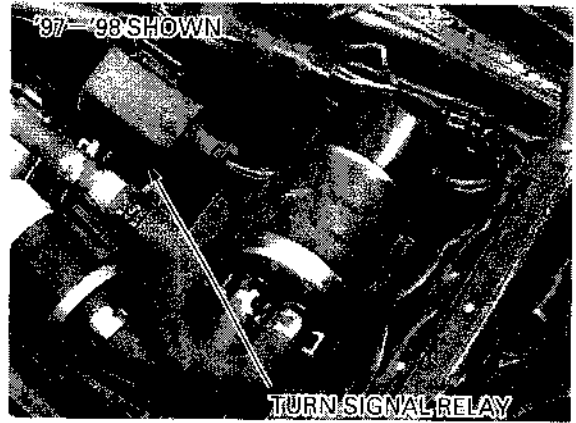

# SIDE STAND SWITCH

## INSPECTION

Remove the left side cover (page 2-3).

Disconnect the side stand 3P (Green/'97 - '98, Black/'98 - '00) 2P (Green/After '00) connector.

Check for continuity between each of the terminals as below.  
 There should be continuity between the ○-○ positions on the chart below.

## SIDE STAND SWITCH

'97 - '00

	G/W	Y/BI	G
Side stand down		○	○
Side stand up	○		○

After '00

	G/W	G
Side stand down		○
Side stand up	○	○

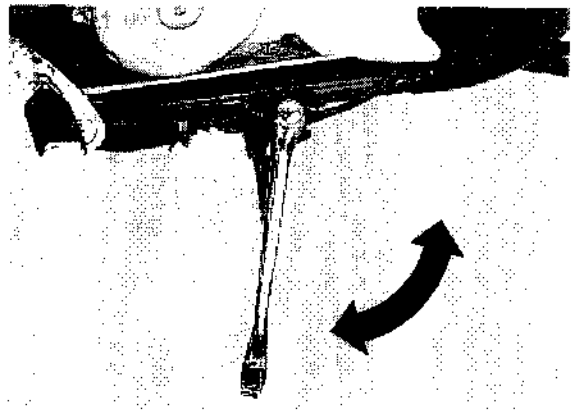

NEW

**REMOVAL/INSTALLATION**

Remove the left side cover (page 2-3).

Disconnect the side stand 3P (Green/'97-'98, Black/'98-'00) 2P (Green/After '00) connector.

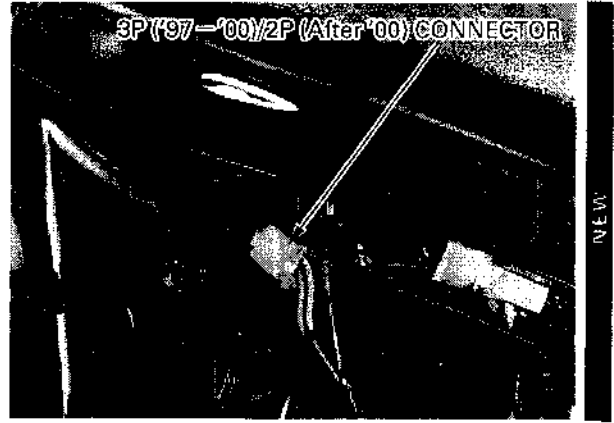

NEW

Remove the side stand switch bolt, switch holder ('97-'98), washer and side stand switch.

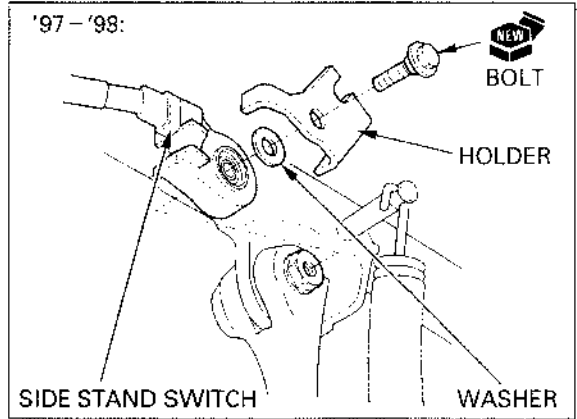

'97-'98: Install the side stand switch by aligning the pin on the switch with the hole on the reverse side of the stand.  
Align the tab of the holder with the groove on the switch.

Install the washer, holder, new side stand switch bolt and tighten the bolt to the specified torque.

**TORQUE:** 9 N·m (0.9 kgf·m , 6.5 lbf·ft)

After '98: Install the side stand switch by aligning the pin on the switch with the hole, and aligning the groove on the switch with the pin on the front side of the stand.

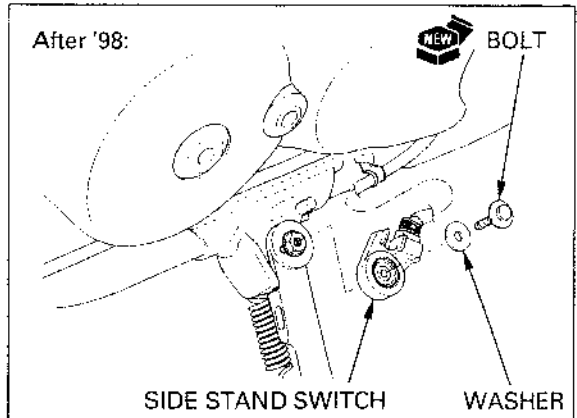

Install and tighten the new side stand switch bolt to the specified torque.

**TORQUE:** 9 N·m (0.9 kgf·m , 6.5 lbf·ft)

**NOTE:**

Route the side stand switch wire properly (page 1-22).

**NEW** Connect the side stand switch 3P (Green/'97-'98, Black/'98-'00) 2P (Green/After '00) connector.

Install the left side cover (page 2-3).

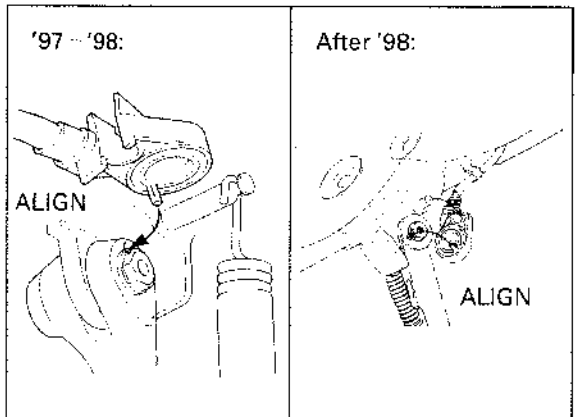

# 20. WIRING DIAGRAM

After '93:

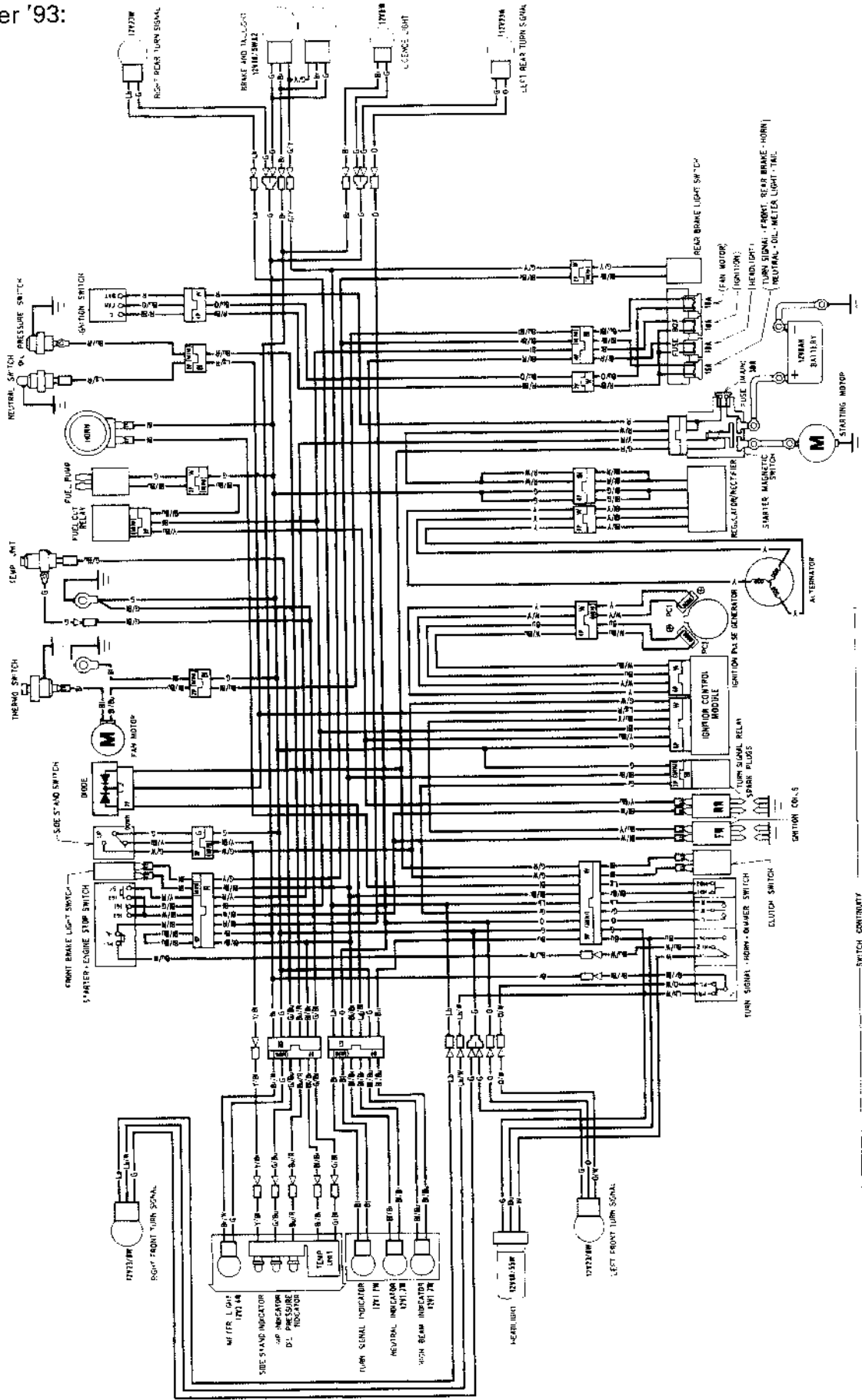

00302-MZ8-0000

# WIRING DIAGRAM

'98-'00

NEW

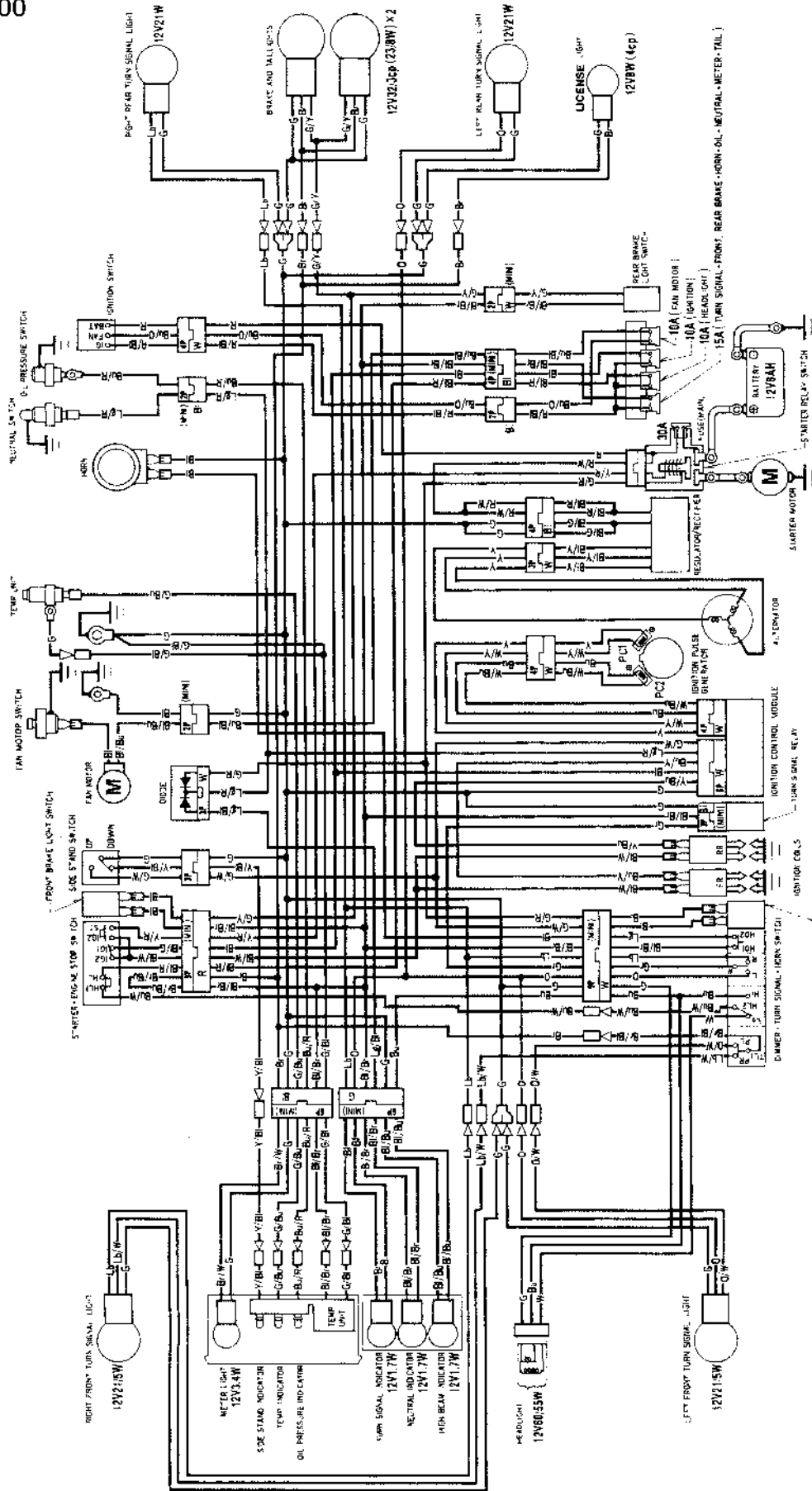

- B BLACK
- Y YELLOW
- B BLUE
- G GREEN
- R RED
- W WHITE
- BR BROWN
- O ORANGE
- LB LIGHT BLUE
- LG LIGHT GREEN
- PK PINK
- GR GRAY

0030Z-MZ8-L500

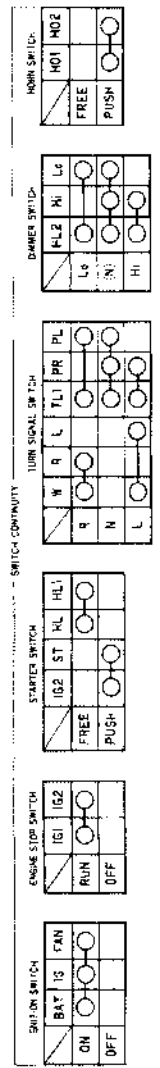



After '00

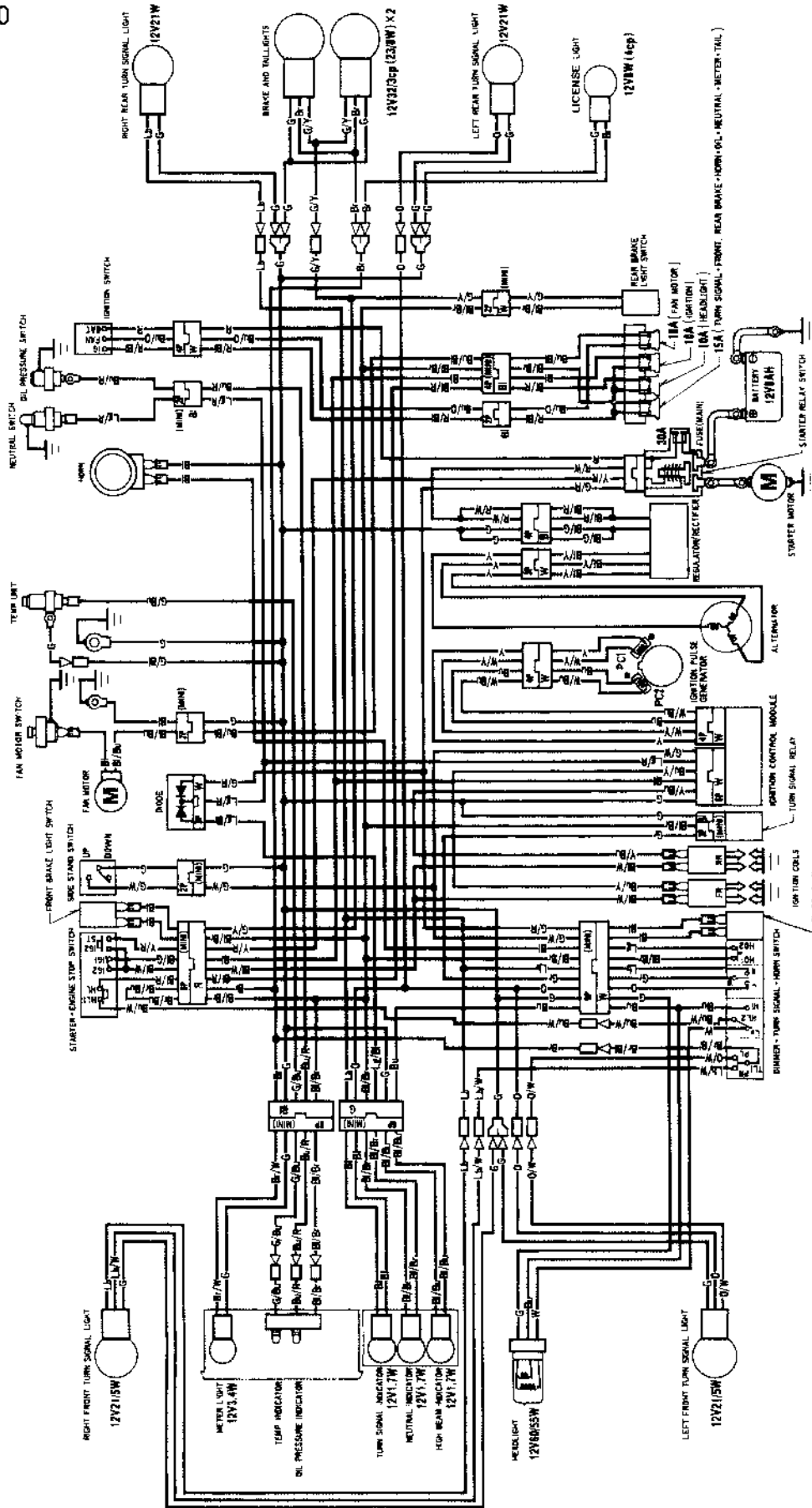

- 0030Z-MZ8-V000
- BLACK
  - YELLOW
  - BLUE
  - GREEN
  - RED
  - WHITE
  - BROWN
  - LIGHT BLUE
  - LIGHT GREEN
  - PINK
  - GRAY

HORN SWITCH	NO1	NO2
	FREE	PUSH

DIMMER SWITCH	HL2	HL1				
	Lo					
TURN SIGNAL SWITCH	HL2	HL1				
	Lo	(N)	Hi			

STARTER SIGNAL SWITCH	W	R	L	TL1	PR	PL
	R	N	L			

STARTER SWITCH	IS2	ST	HL	HL1
	FREE			
ENGINE STOP SWITCH	IS1	IS2		
	RUN	OFF		

IGNITION SWITCH	IGN1	IGN	IGN2
	ON	OFF	

NEW



# 21. TROUBLESHOOTING

ENGINE DOES NOT START OR IS HARD TO START	21-1	POOR PERFORMANCE AT HIGH SPEED	21-4
ENGINE LACKS POWER	21-2	POOR HANDLING	21-4
POOR PERFORMANCE AT LOW AND IDLE SPEED	21-3		

## ENGINE DOES NOT START OR IS HARD TO START

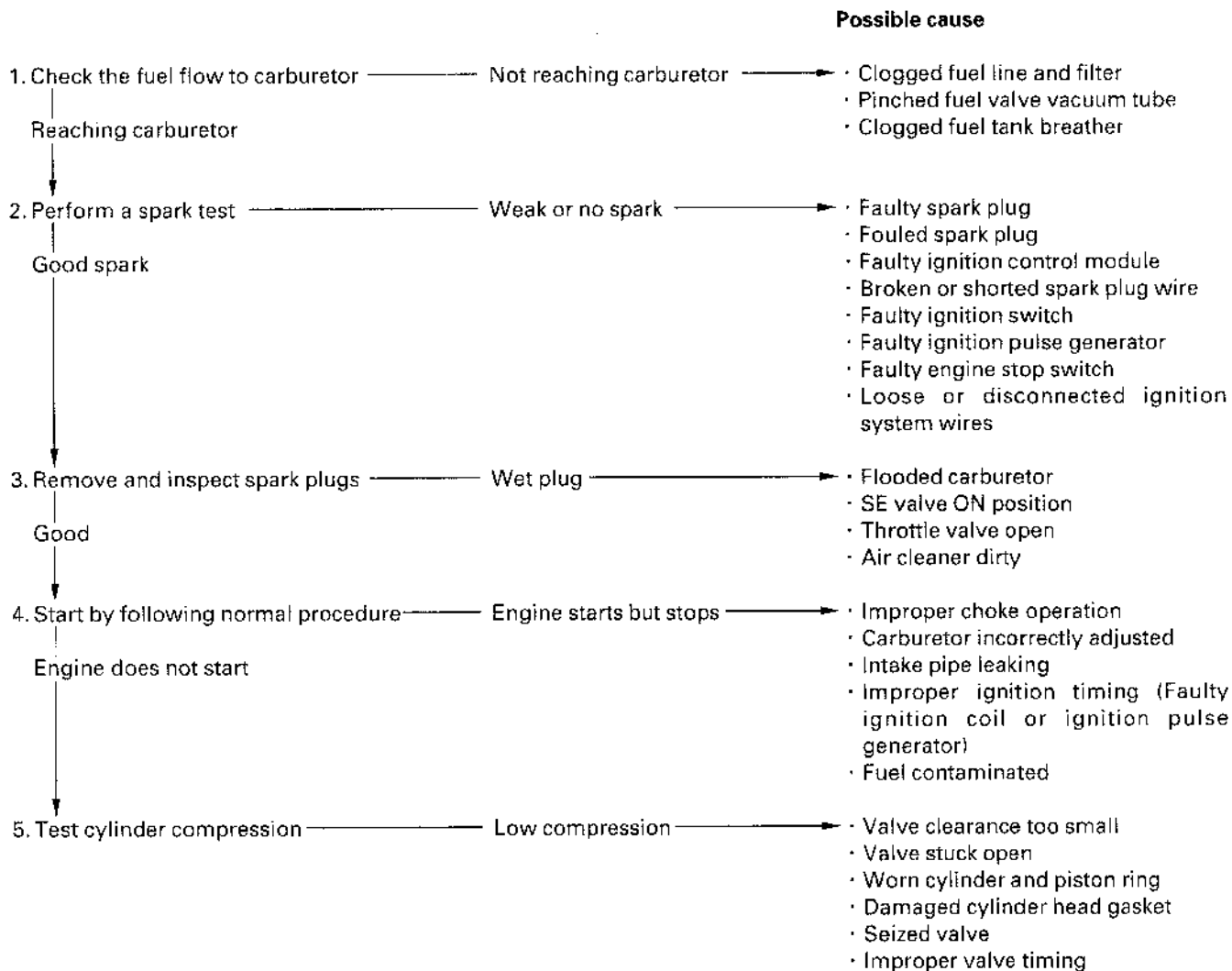

# TROUBLESHOOTING

## ENGINE LACKS POWER

### Possible cause

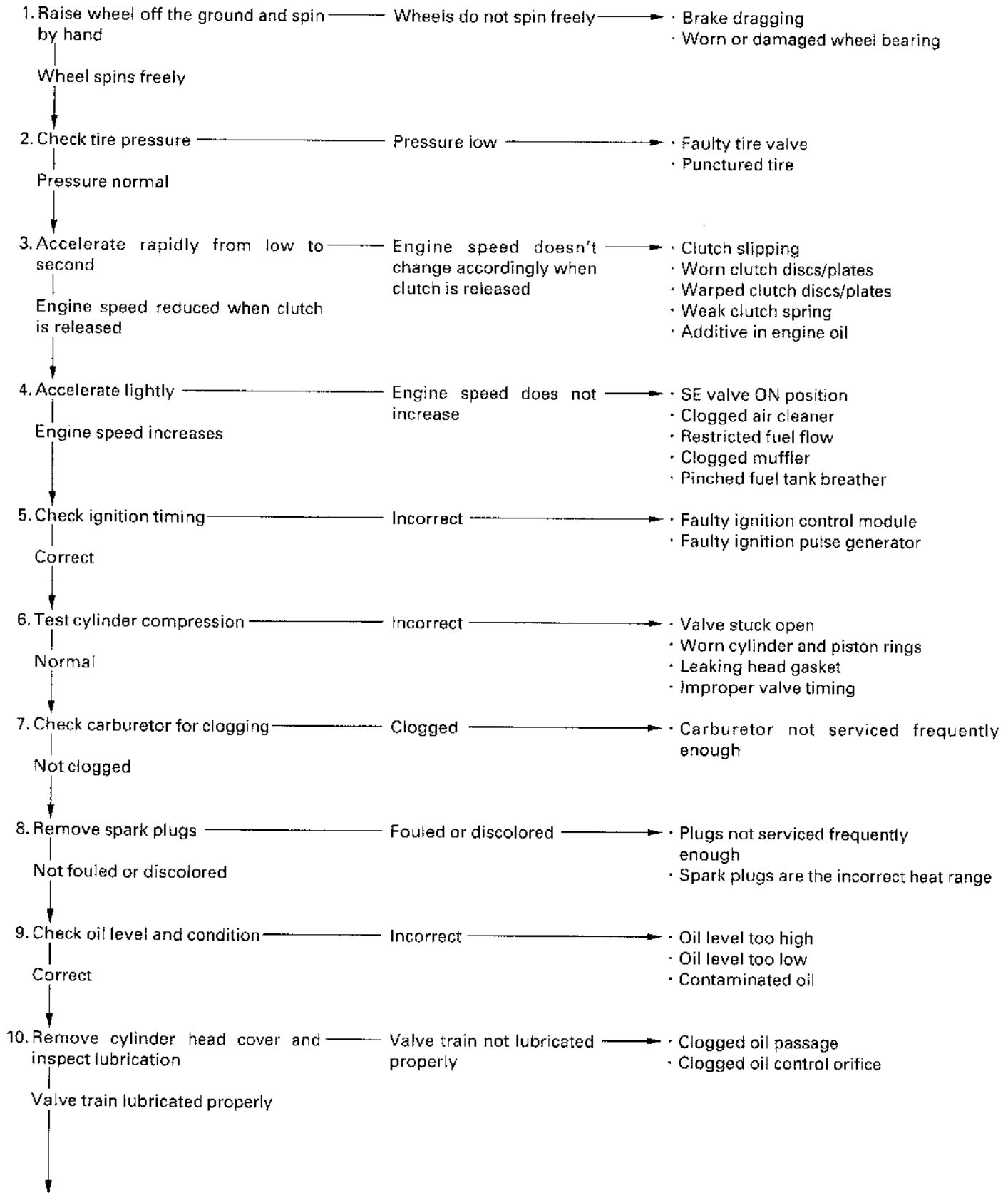

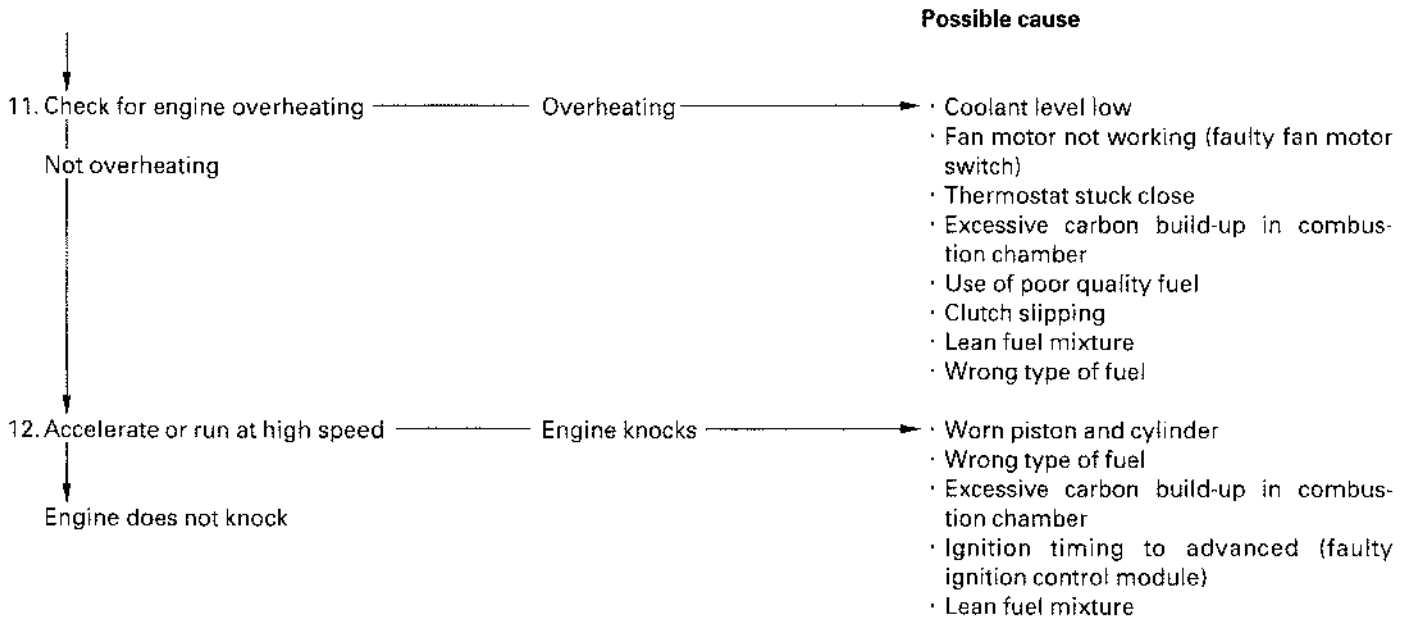

**POOR PERFORMANCE AT LOW AND IDLE SPEED**

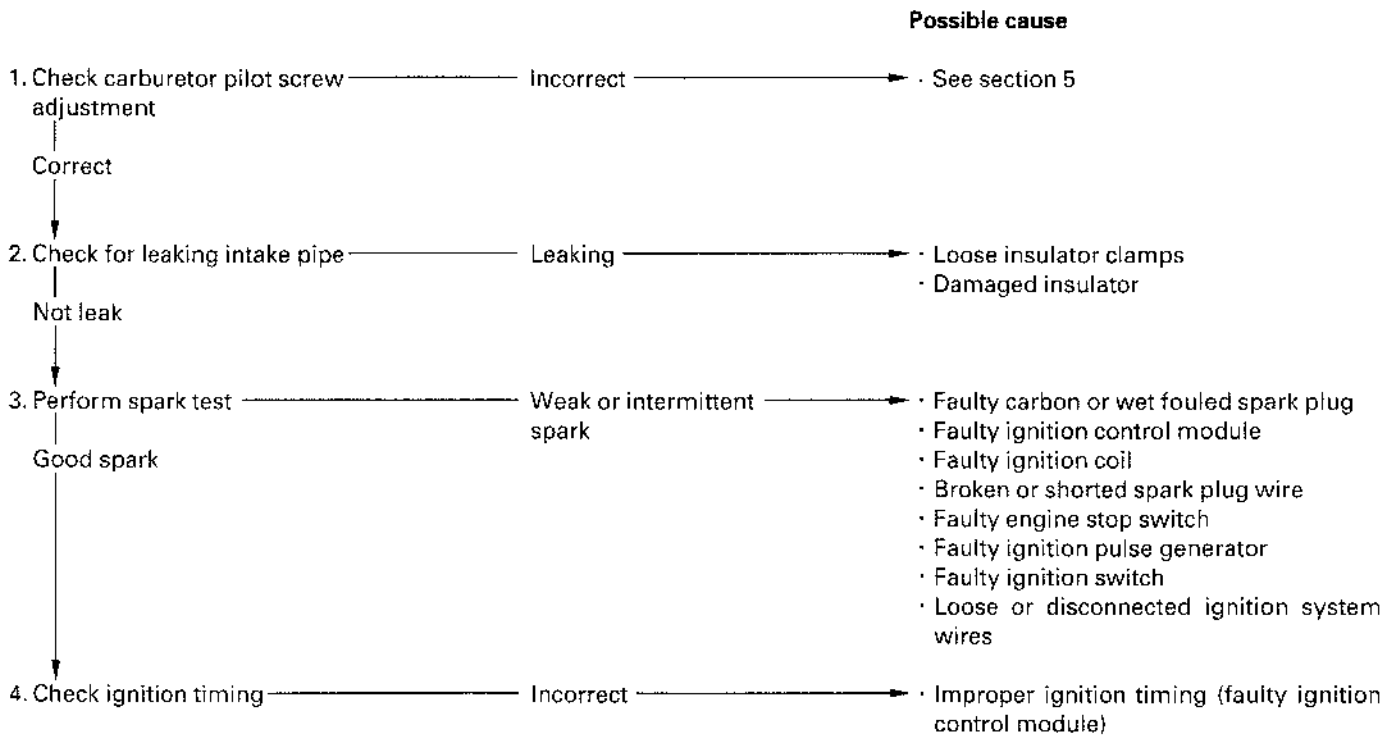

## TROUBLESHOOTING

---

### POOR PERFORMANCE AT HIGH SPEED

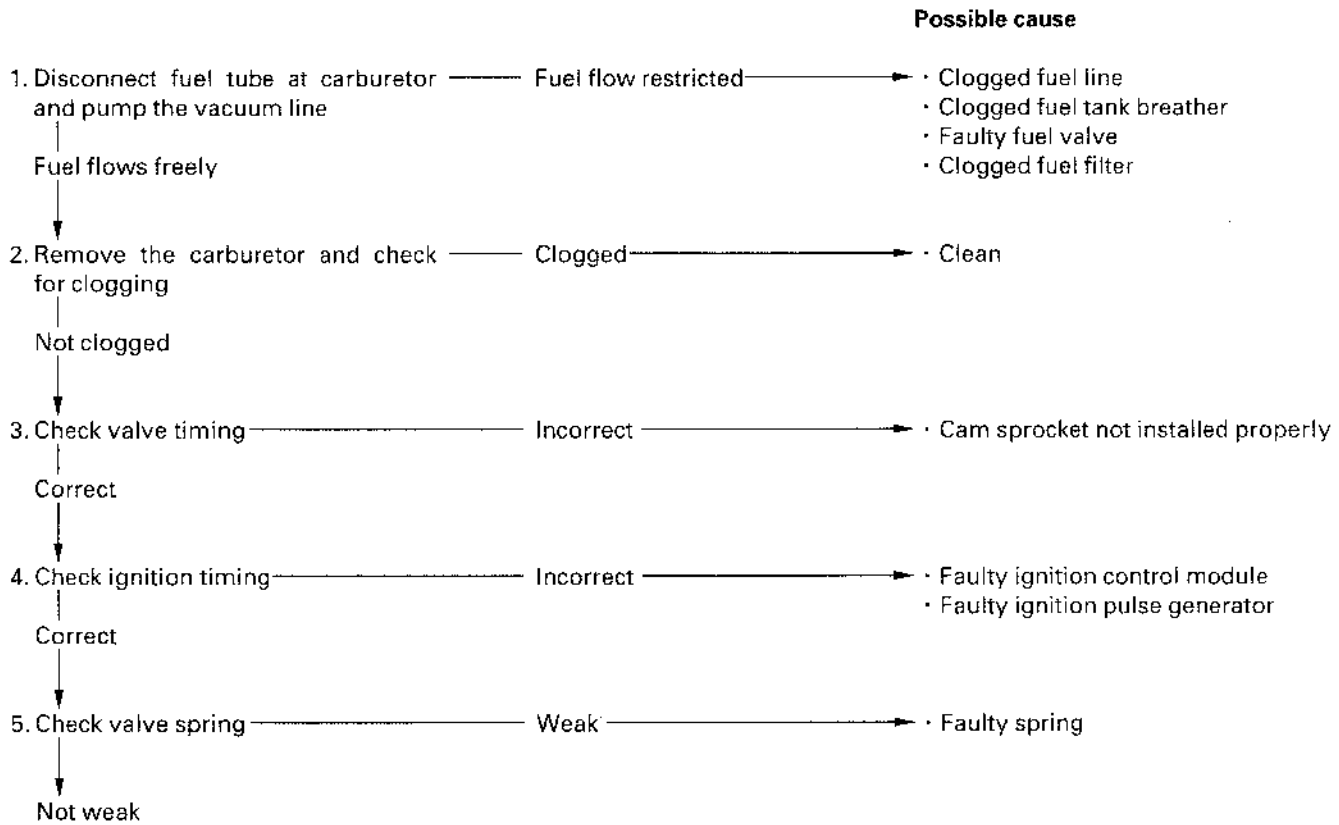

### POOR HANDLING

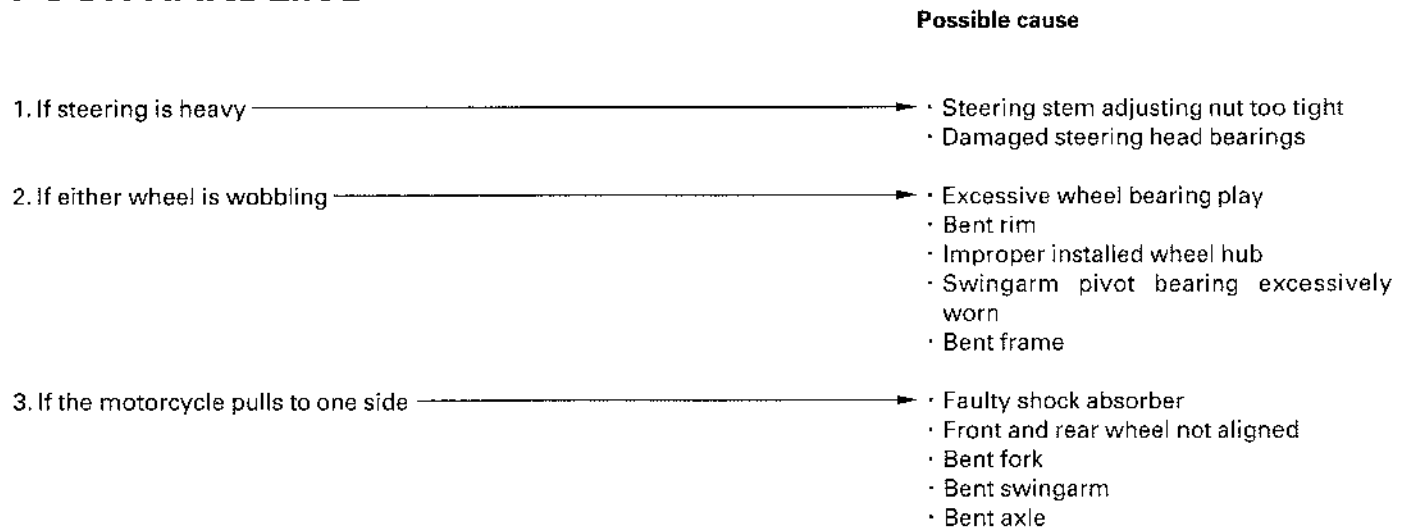

# 22. INDEX

AIR CLEANER	3-8	ENGINE IDLE SPEED	3-18
AIR CLEANER CHAMBER	5-7	ENGINE INSTALLATION	7-9
AIR CLEANER HOUSING	5-4	ENGINE LACKS POWER	21-2
AIR CUT-OFF VALVE	5-22	ENGINE OIL/OIL FILTER	3-14
BATTERY	16-5	ENGINE REMOVAL	7-5
BRAKE CALIPER	15-13	EVAPORATIVE CARBURETOR AIR VENT CONTROL VALVE INSPECTION (CALIFORNIA TYPE ONLY)	5-41
BRAKE FLUID	3-24	EVAPORATIVE EMISSION CONTROL SYSTEM (CALIFORNIA TYPE ONLY)	3-20
BRAKE FLUID REPLACEMENT/AIR BLEEDING	15-3	EVAPORATIVE EMISSION PURGE CONTROL VALVE INSPECTION (CALIFORNIA TYPE ONLY)	5-39
BRAKE LIGHT SWITCH	3-27	EXHAUST PIPE/MUFFLER	2-14
BRAKE PAD/DISC	15-5	FAN MOTOR SWITCH	19-12
BRAKE PEDAL	14-14	FLOAT CHAMBER	5-17
BRAKE SHOE/PAD WEAR	3-25	FLYWHEEL, STARTER CLUTCH FORK	9-3
BRAKE SYSTEM	3-26	FRONT BRAKE LIGHT SWITCH	19-9
BULB REPLACEMENT	19-3	FRONT WHEEL	13-13
CABLE & HARNESS ROUTING	1-22	FUEL AUTO VALVE (After '98)	5-35
CAMSHAFT INSTALLATION	10-25	FUEL FILTER ('97 - '98)	5-34
CAMSHAFT REMOVAL	10-7	FUEL LINE	3-4
CARBURETOR BODY CLEANING	5-23	FUEL PUMP ('97 - '98)	5-32
CARBURETOR CHOKE	3-6	FUEL TANK	2-4
CARBURETOR DISASSEMBLY/ASSEMBLY	5-13	GEARSHIFT LINKAGE	8-12
CARBURETOR REASSEMBLY ('97 - '98)	5-24	GENERAL SAFETY	1-1
CARBURETOR REASSEMBLY (After '98)	5-26	HANDLEBAR	13-4
CARBURETOR INSTALLATION ('97 - '98)	5-26	HANDLEBAR SWITCH	19-10
CARBURETOR INSTALLATION (After '98)	5-27	HEADLIGHT AIM	3-28
CARBURETOR REMOVAL ('97 - '98)	5-10	HIGH ALTITUDE ADJUSTMENT (U.S.A. ONLY/'97 - '98)	5-37
CARBURETOR REMOVAL (After '98)	5-11	HIGH ALTITUDE ADJUSTMENT (U.S.A. ONLY/After '98)	5-38
CARBURETOR SEPARATION ('97 - '98)	5-12	HORN	19-14
CARBURETOR SYNCHRONIZATION	3-17	IGNITION COIL	17-8
CHARGING SYSTEM INSPECTION	16-7	IGNITION CONTROL MODULE (ICM)	17-7
CLUTCH DIODE	18-14	IGNITION SWITCH	19-11
CLUTCH INSTALLATION	8-16	IGNITION SYSTEM INSPECTION	17-4
CLUTCH REMOVAL	8-5	IGNITION TIMING	17-9
CLUTCH SWITCH	19-10	LUBRICATION & SEAL POINTS	1-19
CLUTCH SYSTEM	3-28	MAINTENANCE SCHEDULE	3-3
COOLANT	6-5	MASTER CYLINDER	15-7
COOLANT TEMPERATURE INDICATOR, THERMOSENSOR	19-13	MODEL IDENTIFICATION	1-3
COOLING SYSTEM	3-19	NEUTRAL INDICATOR/SWITCH	19-9
CRANKCASE ASSEMBLY	12-25	NUTS, BOLTS, FASTENERS	3-30
CRANKCASE BEARING REPLACEMENT	12-23	OIL PRESSURE CHECK	4-3
CRANKCASE BREATHER	3-9	OIL PRESSURE INDICATOR/SWITCH INSPECTION	19-8
CRANKCASE SEPARATION	12-4	OIL PUMP	4-4
CRANKCASE STUD BOLT INSPECTION	11-7	PILOT SCREW ADJUSTMENT ('97 - '98)	5-29
CRANKSHAFT/CONNECTING ROD	12-6	PILOT SCREW ADJUSTMENT (After '98)	5-30
CYLINDER COMPRESSION	10-4	PISTON INSTALLATION	11-8
CYLINDER HEAD ASSEMBLY	10-21	PISTON REMOVAL	11-5
CYLINDER HEAD COVER INSTALLATION	10-31	POOR HANDLING	21-4
CYLINDER HEAD COVER REMOVAL	10-5	POOR PERFORMANCE AT HIGH SPEEDS	21-4
CYLINDER HEAD DISASSEMBLY	10-14	POOR PERFORMANCE AT LOW IDLE SPEEDS	21-3
CYLINDER HEAD INSTALLATION	10-23	PRIMARY DRIVE GEAR	8-9
CYLINDER HEAD REMOVAL	10-13	RADIATOR COOLANT	3-19
CYLINDER INSTALLATION	11-9	RADIATOR RESERVE TANK	6-18
CYLINDER REMOVAL	11-3	RADIATOR/COOLING FAN	6-8
DRIVE CHAIN	3-20	REAR BRAKE	14-11
DRIVE SPROCKET INSTALLATION	7-14		
DRIVE SPROCKET REMOVAL	7-4		
EMISSION CONTROL INFORMATION LABELS	1-36		
EMISSION CONTROL SYSTEMS	1-31		
ENGINE DOES NOT START OR IS HARD TO START	21-1		

## INDEX

---

REAR BRAKE LIGHT SWITCH	19-10	TROUBLESHOOTING	
REAR FENDER/REAR SUB FRAME	2-8	(ALTERNATOR/STARTER CLUTCH)	9-1
REAR WHEEL	14-3	(BATTERY/CHARGING SYSTEM)	16-3
REGULATOR/RECTIFIER	16-9	(CLUTCH/GEARSHIFT LINKAGE)	8-2
RIGHT CRANKCASE COVER REMOVAL	8-3	(COOLING SYSTEM)	6-3
RIGHT CRANKCASE COVER INSTALLATION	8-20	(CRANKSHAFT/TRANSMISSION)	12-3
SEAT	2-2	(CYLINDER HEAD/VALVES)	10-3
SERVICE INFORMATION		(CYLINDER/PISTON)	11-2
(ALTERNATOR/STARTER CLUTCH)	9-1	(ELECTRIC STARTER)	18-2
(BATTERY/CHARGING SYSTEM)	16-1	(FRAME/BODY PANELS/EXHAUST SYSTEM)	2-1
(CLUTCH/GEARSHIFT LINKAGE)	8-1	(FRONT WHEEL/SUSPENSION/STEERING)	13-3
(COOLING SYSTEM)	6-1	(FUEL SYSTEM)	5-3
(CRANKSHAFT/TRANSMISSION)	12-2	(HYDRAULIC BRAKE)	15-2
(CYLINDER HEAD/VALVES)	10-1	(IGNITION SYSTEM)	17-3
(CYLINDER/PISTON)	11-1	(LUBRICATION SYSTEM)	4-2
(ENGINE REMOVAL/INSTALLATION)	7-3	(REAR WHEEL/BRAKE/SUSPENSION)	14-2
(ELECTRIC STARTER)	18-1	TURN SIGNAL RELAY	19-15
(FRAME/BODY PANELS/EXHAUST SYSTEM)	2-1	VACUUM CHAMBER	5-15
(FRONT WHEEL/SUSPENSION/STEERING)	13-1	VALVE CLEARANCE	3-11
(FUEL SYSTEM)	5-2	VALVE GUIDE REPLACEMENT	10-17
(HYDRAULIC BRAKE)	15-1	VALVE SEAT INSPECTION/REFACING	10-19
(IGNITION SYSTEM)	17-1	WATER PUMP	6-15
(LIGHTS/METERS/SWITCHES)	19-1	WHEELS/TIRES	3-30
(LUBRICATION SYSTEM)	4-1		
(MAINTENANCE)	3-1		
(REAR WHEEL/BRAKE/SUSPENSION)	14-1		
SERVICE RULES	1-2		
SHOCK ABSORBER	14-18		
SIDE COVER	2-3		
SIDE STAND	3-29		
SIDE STAND SWITCH	19-15		
SPARK PLUG	3-9		
SPECIFICATIONS	1-5		
SPEEDOMETER	19-6		
STARTER MOTOR	18-4		
STARTER RELAY SWITCH	18-13		
STATOR INSTALLATION	9-9		
STATOR REMOVAL	9-2		
STEERING COVER	2-3		
STEERING HEAD BEARINGS	3-31		
STEERING STEM	13-35		
SUB-AIR CLEANER ELEMENT ('97 - '98)	5-6		
SUSPENSION	3-29		
SWINGARM	14-22		
SYSTEM DIAGRAM			
(BATTERY/CHARGING SYSTEM)	16-0		
(ELECTRIC STARTER)	18-0		
(IGNITION SYSTEM)	17-0		
(LIGHTS/METERS/SWITCHES)	19-0		
SYSTEM FLOW PATTERN	6-0		
SYSTEM TESTING	6-4		
THERMOSTAT	6-7		
THROTTLE OPERATION	3-4		
TOOLS	1-17		
TORQUE VALUES	1-14		
TRANSMISSION	12-14		