



# MUSTANGSTEVE

MUSTANGSTEVE.COM

rev 160516

## GT2015-FT

## Disc Brake Conversion

## Installation Instructions

1. Remove existing drum/hub as a unit from the spindle. Remove backing plate from spindle. Disconnect rubber brake hose from steel line and frame bracket. Remove backing plate and hose.
2. Place drum, open side down, in a press and place a plate across the outer bearing retainer part of the hub and press the hub out of the drum. Retain hub with studs intact.
3. Longer wheel studs are recommended due to the slight extra thickness of the rotor and use of alloy wheels. MustangSteve shoulderless studs are longer than stock and work perfectly. Available from MustangSteve as a set of ten. **IF USING ORIGINAL STUDS, DO NOT ATTEMPT TO INSTALL ROTOR WITHOUT CHECKING TO BE SURE THE ROTOR'S STUD HOLES WILL FIT OVER THE STUD SHOULDERS.**
4. **IMPORTANT:** Be sure the outer flange OD of the hub flange is smaller than the ID of the rear face of the rotor. Ref: VIEW 1.3. Different rotor and hub manufacturers use different dimensions. If this is not checked, and the hub is too large to fit flat against the back of the rotor, you will never get the rotor placed flat onto the studs properly. If the hub is too large, the OD must be reduced on a lathe or using a hand grinder so it fits into the rotor. Using a grinder is OK, and there will not be balance issues if not perfectly round. This does not usually require removal of more than 0.060" off the diameter of the hub flange. **This issue MUST BE ADDRESSED.** Whenever someone has a problem with an installation, the error usually comes back to this step.
5. Place the supplied rotor centering ring on the hub, and use a drift punch to push the ring, which is a press fit, onto the hub snout. There is a small radius on the hub face which will prevent the ring from seating flat against the hub face. That is OK as long as the ring is evenly installed. At this point, the rotor should be able to be installed on the hub without undue force. It should fit snug around the ring and slide easily over the wheel studs. Temporarily secure the rotor to the hub using two or three lug nuts. This will keep you from jarring the rotor loose from the studs while mounting it. Ref: VIEW 1.2
6. Using the supplied (4) 3/8" bolts, mount bracket A to the spindle. Using the 1/2" bolts, mount bracket B to bracket A with the shim between the two brackets. Use the supplied lock washers and nuts. Bolts can go in from either direction. Use of Red Loctite is recommended. Ref: VIEW 1.1
7. Mount the hub/rotor to the spindle. Adjust bearings and check for rotor runout.
8. Install the caliper onto the steel bracket using (2) supplied 12mm hardened steel flange-head bolts. Blue Loctite or equivalent thread lock compound is recommended, but not required.
9. Use 3/16" steel tubing (not supplied with kit) to construct the new brake lines. Original caliper hoses can be used if modified as shown on page 4. Mount solid to frame.
10. You must use a master cylinder with at least 15/16" bore size, designed to work with disc brakes. Master cylinders with bore larger than 1" may not be capable of producing adequate line pressure for these brakes and should be avoided. (MustangSteve master cylinders PB-6.1 and PB-6.2 are compatible with these brakes. See Page 4 of instructions.
11. You must have a proportioning valve in the rear brake line when installing discs up front. (MustangSteve PV-100-CHR Proportioning valve is available. See Page 5 of instructions.

## GT2015-FT

VERSION 131022

NOTE:  
LEFT (DRIVER'S) SIDE SHOWN.  
RIGHT SIDE IS A MIRROR INSTALLATION

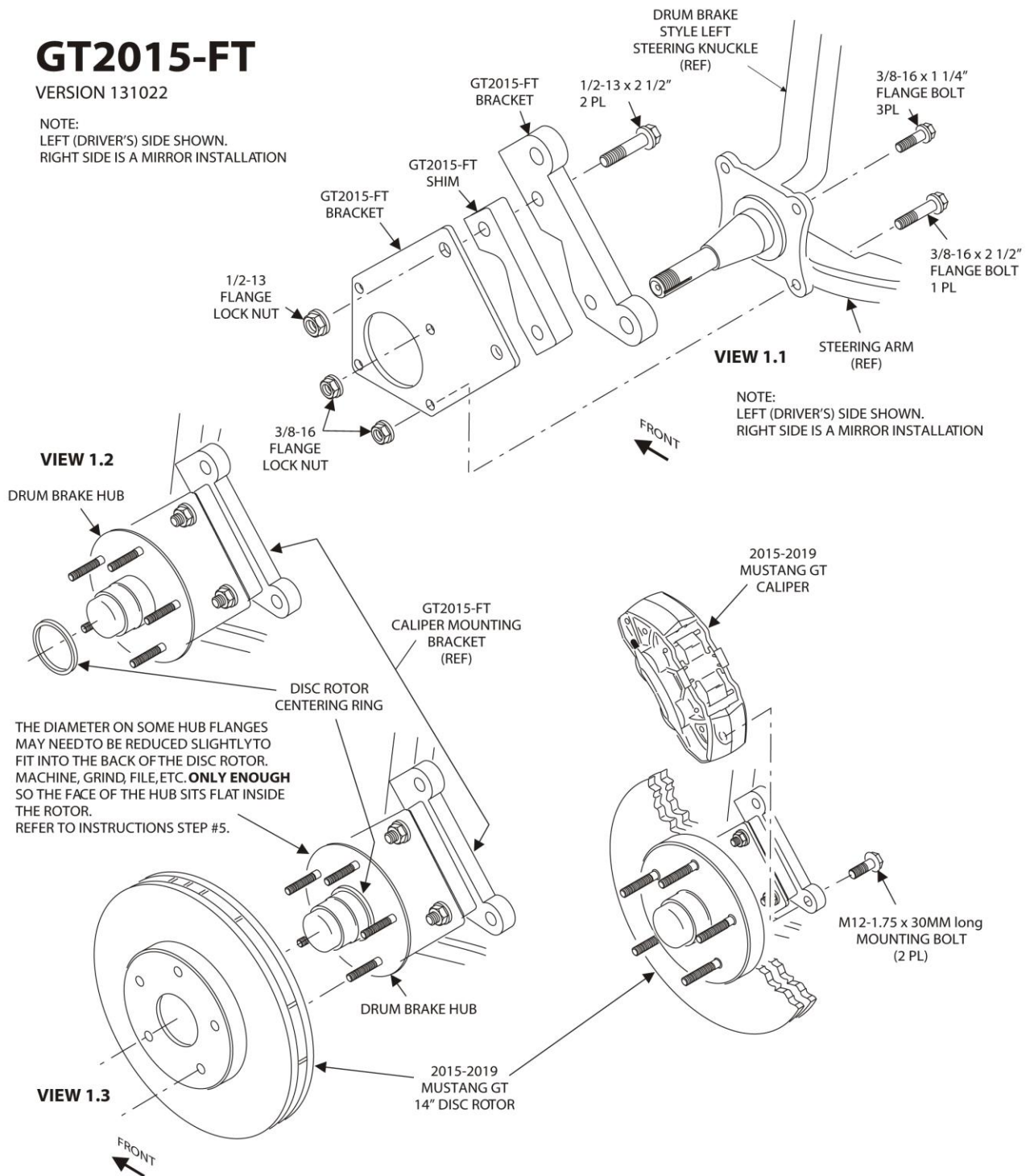

**DRIVER SIDE SHOWN**

ALL BRAKE WORK SHOULD BE DONE BY A MECHANIC WHO IS COMPETENT WITH THE MODIFICATION OF YOUR CAR'S BRAKE SYSTEM. MustangSteve IS NOT RESPONSIBLE FOR ANY EVENT THAT MIGHT OCCUR IN THE EVENT OF BRAKE FAILURE. THESE BRAKES ARE CONSIDERED RACING ITEMS AND NOT COVERED BY ANY WARRANTY.

Mustang related questions can be posted on the FYIFORD FORUM for quick replies to ANY Mustang questions. Go to [www.mustangsteve.com](http://www.mustangsteve.com) and click on the FYIFORD link.

## REFERENCE INFORMATION

Mustang related questions can be posted on my FYIFORD FORUM for quick replies to ANY Mustang questions.

Go to

[www.mustangsteve.com](http://www.mustangsteve.com)

and click on the FYIFORD link.

If installing brand new brake pads or shoes, DO NOT immediately go out and do a panic stop to see how well they work!!!

This will destroy new pad and shoe material.

New brake pads must be broken in and used in normal driving for 200 or so miles before a super panic stop.

Increasingly hotter brake applications as you are driving will help to bed the new pads. Do not come to a complete stop when doing hot deceleration so the pads do not transfer material to the rotors. Keep driving to let the parts cool down between decelerations.

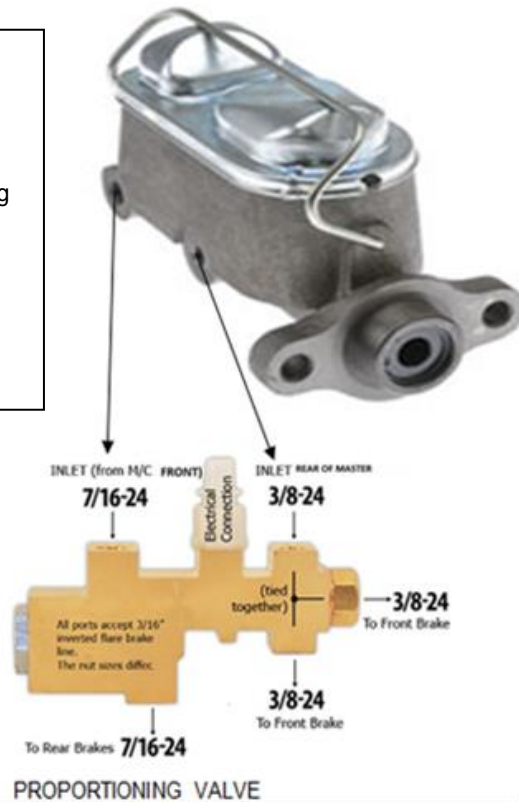
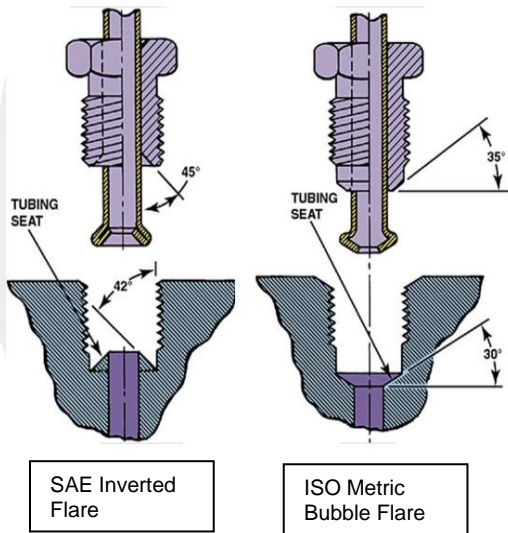

PROPORTIONING VALVE  
**TYPICAL DISC/DRUM SYSTEM**



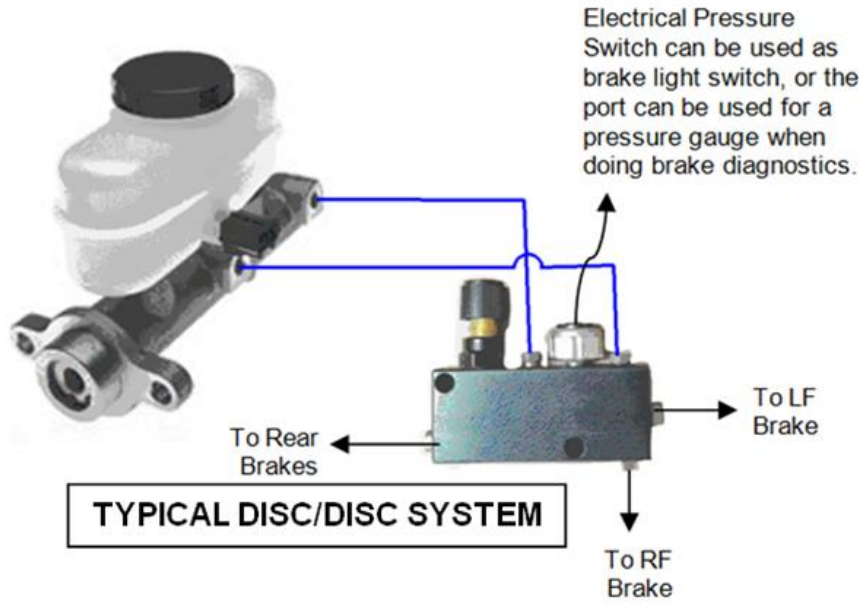

Modify Stock Hose Bracket (remove from hose fitting prior to welding, then rivet it back to the fitting)

Drill 2 holes in frame. Bolt hose end as shown

3/16" Steel Tube  
Use ISO Bubble flare, 10mm threads

- Left Front Frame Rail -

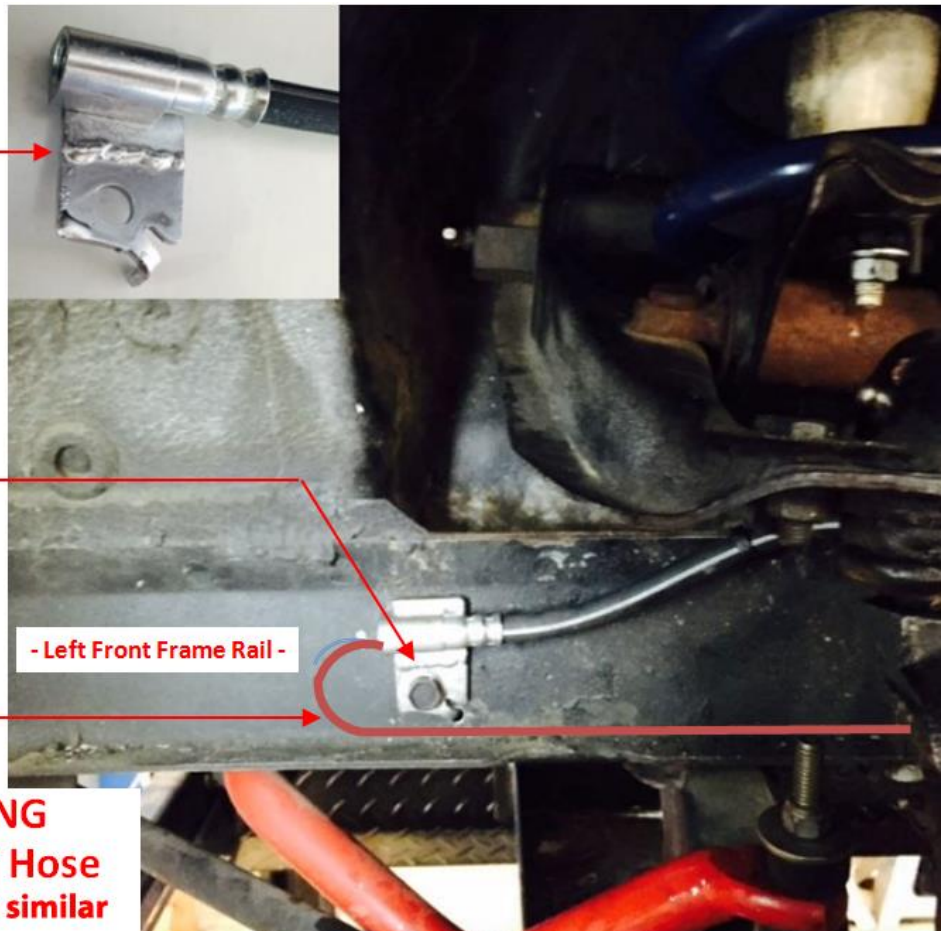

**GT HOSE ROUTING**  
**Stock 2005-2010 GT Hose**  
**GT 2015 - 2018 Hoses are similar**

## RECOMMENDED MASTER CYLINDERS

**Disc/Drum** 67-70 Mustang Power Disc Brake 1" Bore

**MustangSteve Part # PB-6.1**

**Disc/Drum** 74 Maverick non-power disc/drum 15/16" Bore

**MustangSteve Part # PB-6.4**

Note: Use of Maverick MC will result in a longer pedal stroke. Use with manual brakes only.

**Disc/Disc** 2000 Mustang V6 1.00" bore

**MustangSteve Part # PB-6.2**

---

## RECOMMENDED PROPORTIONING VALVES

**Disc/Drum or Disc/Disc** Adjustable valve with distribution block and electric brake light switch

**MustangSteve Part # PB-100-CHR** Matte chrome

Brake light switch port can also be used for pressure gauge port to use in diagnostics

---

Master Cylinders and Proportioning Valves Available at [www.mustangsteve.com](http://www.mustangsteve.com)



**PB-6.1**



**PB-6.2**



**PB-100-CHR**