

STATIM 2000/5000

C a s s e t t e A u t o c l a v e TM

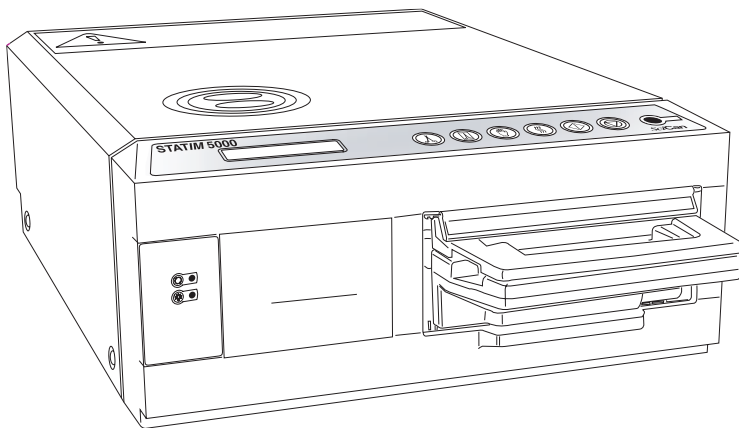
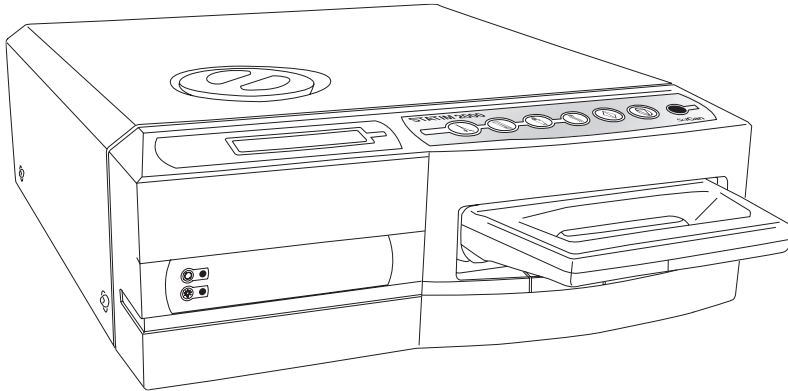

• **Operator's Manual**

SciCan

www.scican.com

STATIM 2000/5000 Operator's Manual 95-108027 Rev 3.0.
Copyright 2004 SciCan. All rights reserved.

Table of Contents

1. Introduction	3
2. Important Information	4
2.1 Disclaimers	
2.2 Statim 2000 — Unit Overview	
2.3 Statim 5000 — Unit Overview	
3. Installation	7
3.1 Environmental Considerations	
3.2 Unit Placement	
3.3 Connecting the Waste Bottle	
3.4 Filling the Reservoir	
3.5 Priming the Statim Pump	
3.6 Language Selection	
3.7 Preparing the Unit for Use	
3.8 Shipping the Unit	
4. Instructions for Use	11
4.1 Statim 2000 — Using the cassette	
4.2 Statim 5000 — Using the cassette	
4.3 Statim 5000 — STAT-DRI Plates	
4.4 Preparing and Loading Instruments	
4.5 Instrument Mass Guide	
4.6 Statim 2000 — Selecting a Cycle	
4.7 Statim 2000 — Running a Cycle	
4.8 Statim 5000 — Selecting a Cycle	
4.9 Statim 5000 — Running a Cycle	
4.10 Stopping a Cycle	
5. Maintenance	28
5.1 Cleaning the Cassette	
5.2 Cleaning the Reservoir	
5.3 Cleaning the Exterior Surfaces	
5.4 Changing the Statim 2000 Air Filter	
5.5 Changing the Bacteria Retentive Air Filters	
5.6 Replacing the Cassette Seal	
5.7 Maintaining Fluid Levels	
5.8 Preventative Maintenance Schedule	
5.9 Spare Parts List	
6. Troubleshooting	34
7. The Optional Statprinter	37
7.1 The Statprinter	
7.2 Installing the Statprinter	
7.3 Setting Time and Date	
7.4 Installing Paper into the Statprinter	
7.5 Removing Paper Jams	
8. Warranty	41
9. Specifications	42
9.1 Statim 2000 — Specifications	
9.2 Statim 5000 — Specifications	

STATIM Cassette Autoclave is a registered trademark of SciCan.
STAT-DRI is a trademark of SciCan. All other trademarks referred to in this manual
are the property of their respective owners.

For all service and repair inquiries:

In Canada 1-800-870-7777
United States: 1-800-572-1211
International: (416) 446-4500
Email: techservice.ca@scican.com

Manufactured by:

SciCan

1440 Don Mills Road,
Toronto ON M3B 3P9
CANADA

Phone: (416) 445-1600
Fax: (416) 445-2727
Toll free: 1-800-667-7733



0 1 2 3

Table des matières

1. Introduction	44
2. Informations importantes	45
2.1 Avertissements	
2.2 Statim 2000 — Vue d'ensemble de l'appareil	
2.3 Statim 5000 — Vue d'ensemble de l'appareil	
3. Installation	48
3.1 Considérations environnementales	
3.2 Mise en place de l'appareil	
3.3 Branchement de la bouteille à eau résiduaire	
3.4 Remplissage du réservoir	
3.5 Amorçage de la pompe Statim	
3.6 Sélection de la langue	
3.7 Préparation de l'appareil pour utilisation	
3.8 Expédition de l'appareil	
4. Instructions d'utilisation	52
4.1 Statim 2000 — Utilisation de la cassette	
4.2 Statim 5000 — Utilisation de la cassette	
4.3 Statim 5000 — Plaques STAT-DRI	
4.4 Préparation et chargement des instruments	
4.5 Guide des poids des instruments	
4.6 Statim 2000 — Sélection d'un cycle	
4.7 Statim 2000 — Exécution d'un cycle	
4.8 Statim 5000 — Sélection d'un cycle	
4.9 Statim 5000 — Exécution d'un cycle	
4.10 Interruption de cycle	
5. Entretien	69
5.1 Nettoyage de la cassette	
5.2 Nettoyage du réservoir	
5.3 Nettoyage des surfaces extérieures	
5.4 Changement du filtre à air Statim 2000	
5.5 Changement des filtres à air retenant les bactéries	
5.6 Remplacement du joint de cassette	
5.7 Maintien des niveaux de liquide	
5.8 Calendrier d'entretien préventif	
5.9 Liste des pièces de rechange	
6. Dépannage	75
7. Imprimante Statprinter en option	78
7.1 Imprimante Statprinter	
7.2 Installation de l'imprimante Statprinter	
7.3 Réglage de l'heure et de la date	
7.4 Installation du papier dans l'imprimante Statprinter	
7.5 Élimination des bourrages du papier	
8. Garantie	82
9. Spécifications	83
9.1 Statim 2000 — Spécifications	
9.2 Statim 5000 — Spécifications	

STATIM Cassette Autoclave est une marque de commerce déposée de SciCan.
STAT-DRI est une marque de commerce de SciCan. Toute autre marque de commerce
dont il est fait mention dans le présent manuel appartient à son propriétaire.

Pour toute demande de renseignements relatifs à l'entretien et aux réparations, contacter :

Au Canada : 1-800-870-7777
aux États-Unis : 1-800-572-1211
International : (416) 446-4500
Courrier électronique : techservice.ca@scican.com

Fabriqué par :

SciCan

1440 Don Mills Road,
Toronto ON M3B 3P9
CANADA

Tél. : (416) 445-1600
Télécop. : (416) 445-2727
Sans frais : 1-800-667-7733



0 1 2 3

1. Introduction

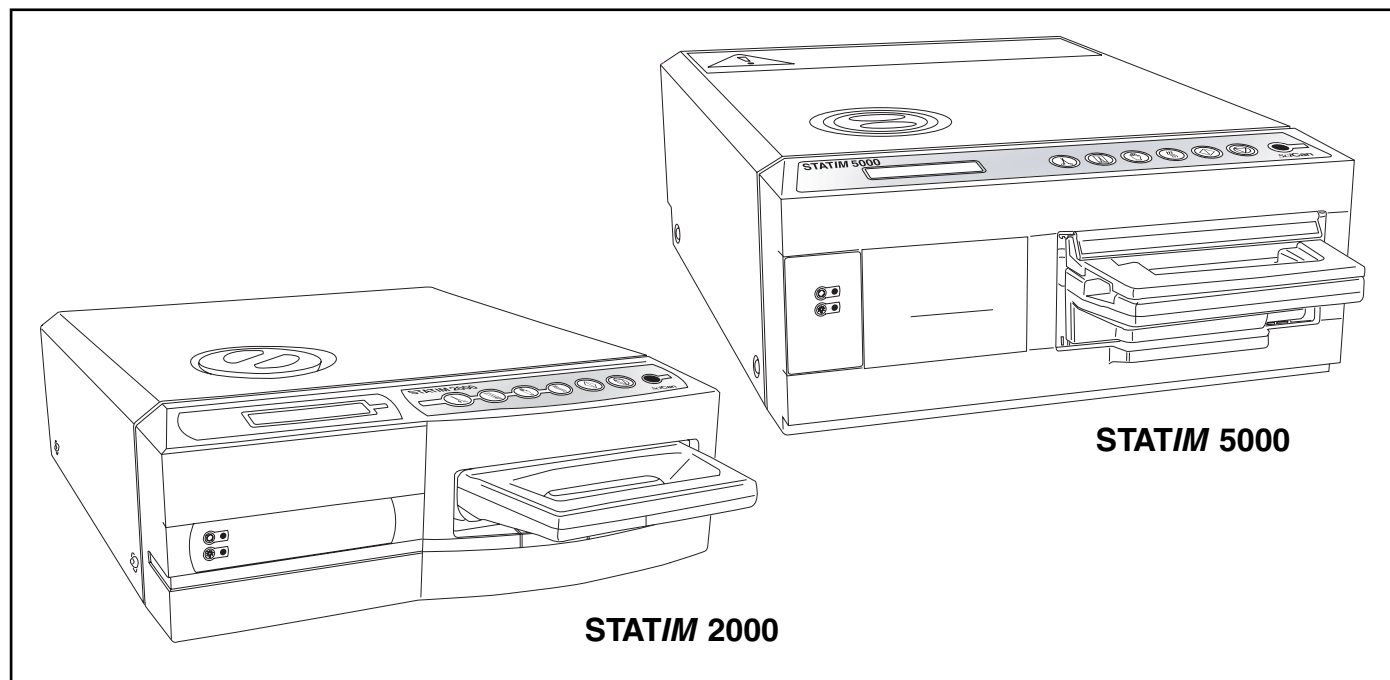

Congratulations on your selection of the STATIM Cassette Autoclave®. We are confident that you have purchased the finest equipment of its type. The Statim is a compact, counter-top unit that features a number of sterilizing cycles designed to meet your needs and suitability for steam sterilization.

The details of installing, operating and servicing your Statim are all contained within this operator's manual. To ensure years of safe, trouble-free service, please read these instructions before operating this unit and keep them for future reference. Operational, maintenance and replacement instructions should be followed for the product to perform as designed. Contents of this manual are subject to change without notice to reflect changes and improvements to the Statim product.

The Statim is suitable for the sterilization of all types of dental and medical instruments designed to withstand steam sterilization. The Statim has not been designed to sterilize liquids, cloth loads, biomedical waste or materials not compatible with steam sterilization. The processing of such loads may result in incomplete sterilization and / or damage to the autoclave. For more information about instrument suitability for steam sterilization, consult the manufacturers' reprocessing instructions.

2. Important Information

2.1 Disclaimers

Use only steam-process distilled water in your Statim. Specially filtered water should not be used. Never use tap water. Usage of any water other than steam-process distilled water may damage the unit and void the warranty.

Do not permit any person other than certified personnel to supply parts for, service or maintain your Statim. SciCan shall not be liable for incidental, special or consequential damages caused by any maintenance or services performed on the Statim by a third party, or for the use of equipment or parts manufactured by a third party, including lost profits, any commercial loss, economic loss, or loss arising from personal injury.

Never remove the cover of the unit and never insert objects through holes or openings in the cabinetry. Doing so may damage the unit and / or pose a hazard to the operator.

For additional information:

SciCan

1440 Don Mills Road,
Toronto, ON M3B 3P9
CANADA
Phone: (416) 445-1600
Fax: (416) 445-2727
Toll free: 1-800-870-7777

SciCan Inc.

500 Business Center Drive
Pittsburgh, PA 15205
USA
Phone: (412) 494-0181
Fax: (412) 494-4794
Toll free: 1-800-572-1211

SciCan Medtech

Alpenstrasse 16, 6300 Zug
SWITZERLAND
Phone: (41-41) 727 -7027
Fax: (41-41) 727 -7029

US service information.

United States: 1-800-572-1211
International: (416) 446-4500
Email: techservice.ca@scican.com

EC Representative:

BHT Hygienetechnik GmbH
Messerschmittstr. 11, D-86368
GERMANY

Email: customer_servicecanada@scican.com

www.scican.com

2. Important Information Cont'd.

2.2 Statim 2000 — Unit overview

Figure 1

- 1 level indicator
- 2 keypad
- 3 reservoir cap
- 4 LCD
- 5 power indicator
- 6 active indicator
- 7 power switch
- 8 power cable port
- 9 leveler feet
- 10 exhaust tube port
- 11 compressor
- 12 cassette

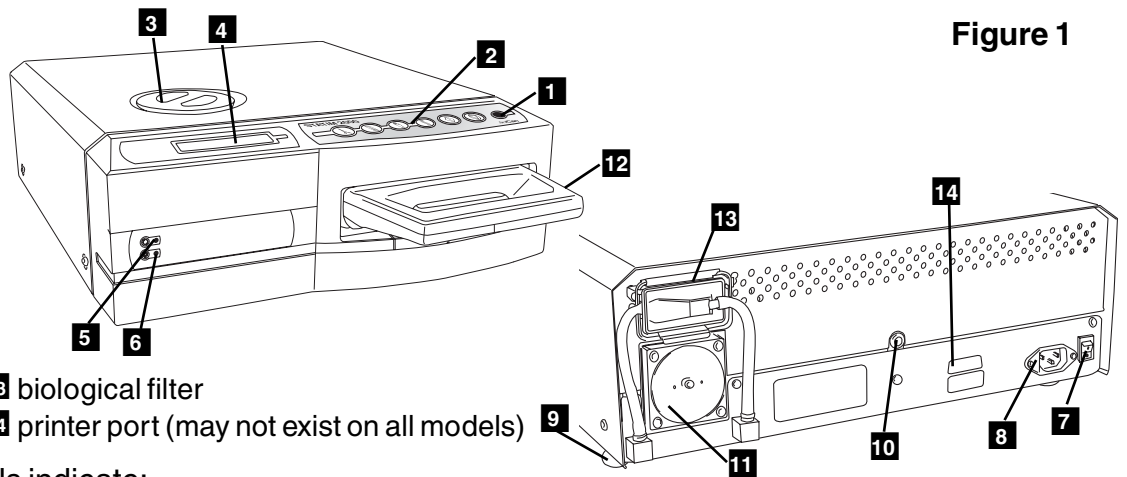

- 13 biological filter
- 14 printer port (may not exist on all models)

The following symbols indicate:



A potential hazard to the operator.



STOP button.



Air dry only button.



A situation which may lead to a mechanical failure.



Unwrapped cycle button.



Power Indicator LED.



Important information.



Wrapped cycle button.



Active Indicator LED.



START button.



Rubber and Plastics cycle button.



Caution Hot Surface.

When you receive your Statim 2000 packing carton, the items listed below will be included.

If any of the items are missing, contact your dealer immediately so the situation can be corrected.

	Cassette Lid and Tray
	Unwrapped Instrument Rack
	Waste Bottle and Bottle Lid fitting
	Tube Mounting Hardware
	Power Cord

	Operator's Manual / 10 Easy Maintenance Tips
	Exhaust Tube
	Stat Dri / Stat Dri Plus

2. Important Information Cont'd.

2.3 Statim 5000 — Unit overview

- 1** level indicator
- 2** keypad
- 3** reservoir cap
- 4** LCD
- 5** power indicator
- 6** active indicator
- 7** power switch
- 8** power cable port
- 9** leveler feet
- 10** exhaust tube port
- 11** biological filter

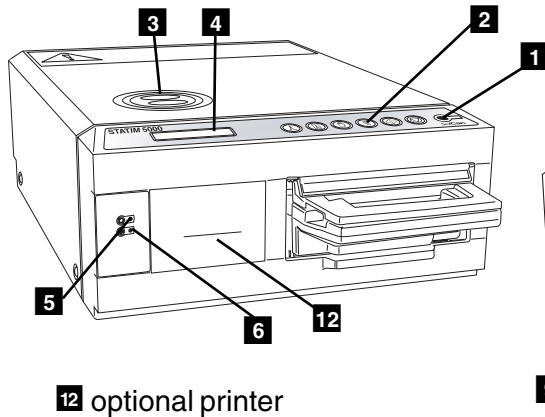

12 optional printer

Figure 2

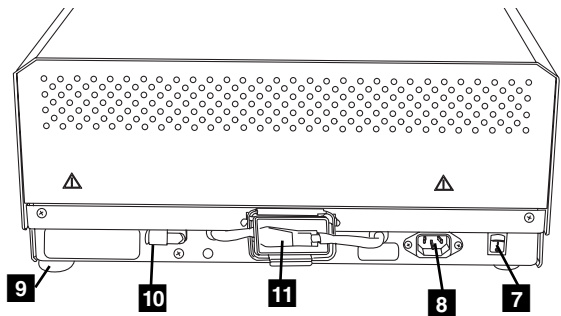

The following symbols indicate:



A potential hazard to the operator.



A situation which may lead to a mechanical failure.



Important information.



START button.



STOP button.



Unwrapped cycle button.



Wrapped cycle button.



Rubber and Plastics cycle button.



Heavy Duty Unwrapped Cycle Button.



Power Indicator LED.







Active Indicator LED.





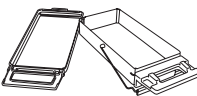

Caution Hot Surface.

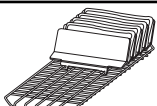
When you receive your Statim 5000 packing carton, the items listed below will be included.

If any of the items are missing, contact your dealer immediately so the situation can be corrected.

	Cassette Lid and Tray
	Unwrapped Instrument Rack
	Wrapped Instrument Rack (Standard with N.A. models only)
	Waste Bottle and Bottle Lid fitting
	Tube Mounting Hardware
	STAT-DRI Plates (Not standard with U.S. models)

	Power Cord
	Operator's Manual / 10 Easy Maintenance Tips
	Exhaust Tube
	Stat Dri / Stat Dri Plus

3. Installation

3.1 Environmental Considerations

There are several factors that may effect the performance of your Statim. Please review these factors, and select a suitable location in which to install the unit.

- **Temperature and Humidity**

Avoid installing your Statim in direct sunlight or close to a heat source (e.g. vents or radiators). The recommended operating temperatures are 15 °C to 25 °C (59 °F to 77 °F) with humidity of 25 % to 70 %.

- **Spacing**

The vents and openings on the Statim should remain uncovered and unobstructed. Leave a minimum of 50 mm / 2 " between the top, sides and back of the unit and any wall or partition.

- **Venting**

The Statim should be operated in a clean, dust-free environment.

- **Work Surface**

The Statim should be placed on a flat, level, water-resistant surface. Never install and operate the unit on a sloped surface.

- **Electromagnetic Environment**

The Statim has been tested and meets applicable standards for electromagnetic emissions. While the unit does not emit any radiation, it may itself be affected by other equipment which does. We recommend that the unit be kept away from potential sources of interference.

- **Electrical Requirements**

Use properly grounded and fused power sources with the same voltage rating as indicated on the label at the back of your Statim. Avoid multiple outlet receptacles. If using a surge suppressor power bar, plug in one Statim only.

3.2 Unit Placement

When placing the unit on a counter top, ensure the following :

- The level indicator bubble **1** on the front panel should be balanced in the front right quadrant of the target. This will ensure that the unit drains properly. Adjusting the three leveler feet will help you move the bubble if necessary.
- The unit should be stable and all four feet should be securely in contact with the counter surface. This will prevent the unit from moving freely.

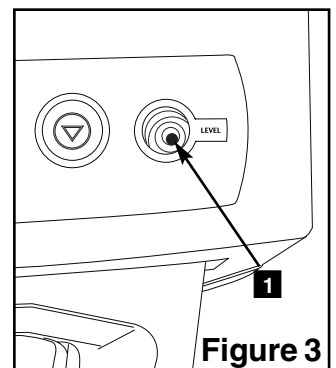

3. Installation Cont'd.

3.3 Connecting the Waste Bottle

The waste bottle **2** is used to collect the wastewater after it has been converted to steam and then drained from the cassette. To connect the waste bottle to the Statim, follow these steps (see Figure 4):



1. Insert the exhaust tube **3** into the fitting **4** on the back of the unit and push firmly.
2. Cut the tube to length and slide the waste bottle fitting **5** into place.
3. Place the free end of the tube into the hole in the lid of the waste bottle and hand-tighten the fitting. Do not coil the exhaust tube.
4. Unscrew the lid and copper condenser coil **6** assembly from the waste bottle. The lid and coil should come out together.
5. Fill the waste bottle with water to the MIN line and replace the lid and copper condenser assembly. Empty the waste bottle often to avoid unpleasant odors and discoloration of the contents. (A low-level chlorine-free disinfectant, prepared according to the manufacturer's instructions, may be added to the waste bottle to remedy this situation). As a minimum, empty the waste bottle each time you refill the reservoir.

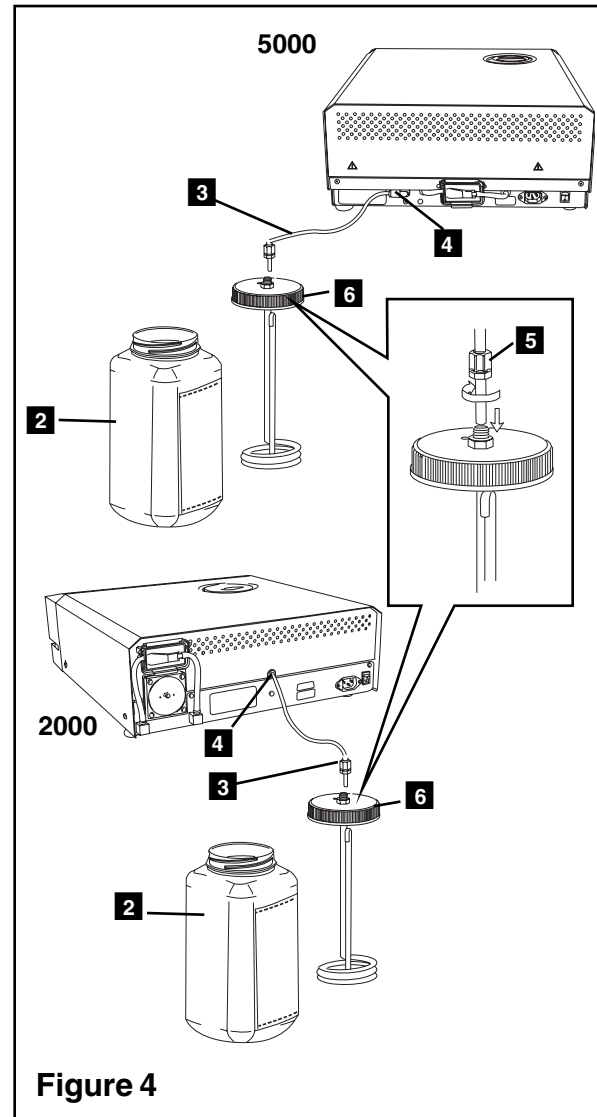

Figure 4

6. Place the waste bottle near the unit. We recommend that you keep it in a cabinet below the unit. The tube can be routed through a hole, (8 mm / 0.3" in diameter) in the counter-top and secured with the nylon clamps supplied.

3.4 Filling the Statim Reservoir

When filling the reservoir, ensure you only use steam processed distilled water containing less than 5ppm total dissolved solids (having conductivity of less than 10 μ S/cm). The impurities and additives in other water sources will cause an error reading on the LCD. If you have a water conductivity meter (available from SciCan, order number 01-103139S) check each new water container before filling the reservoir. To fill the reservoir, follow these steps (see Figure 5):



3. Installation Cont'd.

1. Remove the reservoir cap **2**
2. Pour steam-process distilled water into the reservoir until almost full (a maximum of 4 L / 1 U.S. gal.) Use a funnel to avoid spillage.
3. Replace the cap.

3.5 Priming the Statim Pump

To prime the Statim pump, follow these steps (see Figure 6):

1. Move the unit to the edge of the work surface. The front leveler feet should be approximately 12 mm / 0.5" from the edge.
2. Lift the front left corner of the unit upward and remove the drain tube **3** from the clip located on the underside of the unit.
3. Pull the drain tube outward so the free end can be positioned over a water container.
4. Fill the reservoir with steam-process distilled water.
5. Remove the plug **4** from the end of the drain tube and allow water to drain from the tube into a container. When the water flows in a steady stream, replace the stopper.
6. Lift the front left corner of the unit upward and reinsert the tube into the clip on the underside of the unit. Push the excess length of tubing back into the space provided.

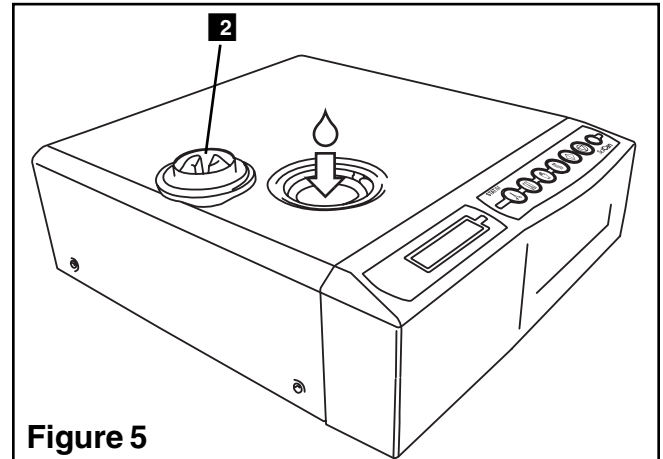

Figure 5

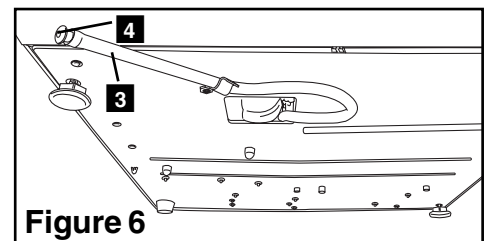

Figure 6



Make sure the plug in the drain tube is secured.

After installation and before sterilizing any instruments, run two Wrapped Cycles. For further instruction, see Section 3.7 Preparing the unit for use.

3.6 Language Selection

The messages displayed on the LCD can be changed to a number of different languages. To change the current language selection, follow these steps:

1. Turn the power switch at the back of the unit **OFF**.
2. For the Statim 2000 press and hold the Wrapped Cycle button. For the Statim 5000 press and hold the Unwrapped Cycle button.
3. While depressing the appropriate button, turn the power switch at the back of the unit to **ON**.

3. Installation Cont'd.

4. Use the Unwrapped or Wrapped cycle buttons to scroll through language selections.
5. When the desired language is displayed, press the **STOP** button to save the selection and return to the regular operating mode.

3.7 Preparing Unit for Use

Once the unit is installed and before any instruments are sterilized, run two Wrapped Cycles (see Sections 4.7 Statim 2000 — Running a Cycle and 4.9 Statim 5000 — Running a Cycle). Remove the cassette once it has cooled. Clean the top (lid) and bottom (tray) sections using a soft cloth to wipe the inside surfaces and then rinse thoroughly with tap water. Once the cassette is clean and dry, coat the inside surfaces with Stat-Dri.

3.8 Shipping the Unit

Before you move the unit, you will need to drain the reservoir. To do so, follow these steps:

1. Place a water container below the unit.
2. Using the drain tube (see Section 3.5 Priming the Pump, Figure 6) empty the contents of the reservoir into the water container.
3. Remove any remaining water from the reservoir with a non-linting absorbant towel.
4. Screw-in the three leveler feet found underneath the unit.
5. Repack the unit in the original packing materials and include all accessories originally included with the unit.
6. Specify heated and insured shipping.

4. Instructions For Use

4.1 Statim 2000 — Using the Cassette



When removing the cassette after a cycle, exercise caution as the metal areas will be hot and the cassette may contain hot steam.

- **To open the cassette:**

1. Hold the cassette handle with your thumbs facing inward on the cassette latch.
2. Push downward on the cassette latch.
3. Raise the cassette lid upwards and disengage the hinge.
4. Rest the lid on its outer surface.

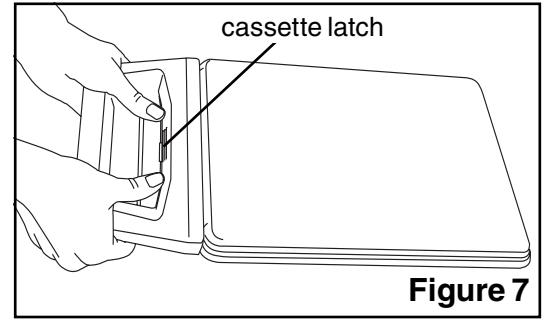

- **To close the cassette:**

1. Align the hinge tab on the cassette lid with the hinge slot on the rear of the bottom tray.
2. As you begin to close the lid, the hinge tab and slot will engage.

- **Inserting the cassette into the Statim 2000:**

1. Place the end of the cassette into the unit.
2. Gently push inward until you hear a “click” sound.



Never push the cassette into the Statim with force as the interior components could be damaged.

- **Removing the cassette:**

1. Grasp the handle with two hands and pull away from the unit.
2. Pull the cassette clear of the unit and set down on a firm surface.

- **Disengaging the cassette**



When not in use, the cassette should be disengaged. To disengage the cassette, grasp the handle and pull the cassette out until there is a 15 mm to 20 mm ($\frac{1}{2}$ " to $\frac{3}{4}$ ") gap between the front of the Statim 2000 and the cassette handle.

- **STAT-DRI/STAT-DRI PLUS**

Treatment of the interior surfaces of the cassette with the Stat-Dri / Stat-Dri Plus drying agent, provided with your unit, will enhance the drying process. (Replacement bottles are available from SciCan, order number 2OZPLUS, 8OZPLUST, 32OZPLUS).

4. Instructions For Use Cont'd.

4.2 Statim 5000 — Using the Cassette



When removing the cassette after a cycle, exercise caution as the metal areas will be hot and the cassette may contain hot steam.

- **To open the cassette:**

1. Push the carry handle **1** into the open position.
2. Put your hands on either side of the cassette handle.
3. Insert your forefingers in the slots and place your thumbs on the thumb pads.
4. Press down with your thumbs and pull up with your forefingers until the lid opens.
5. Raise the cassette lid and disengage from the tray. Rest the lid on the outer surface.

- **To close the cassette:**

1. Align the hinge tab on the lid with the hinge slot on the tray.
2. As you begin to close the lid, the hinge tab and slot will engage.
3. Place the carry handle into the closed position.

- **Inserting the cassette into the Statim 5000:**

1. Hold the cassette handle in one hand and the carry handle in the other as shown in the diagram.
2. Place the end of the cassette into the unit and drop the carry handle into its closed position.
3. Gently push the cassette inward until you hear a click sound.

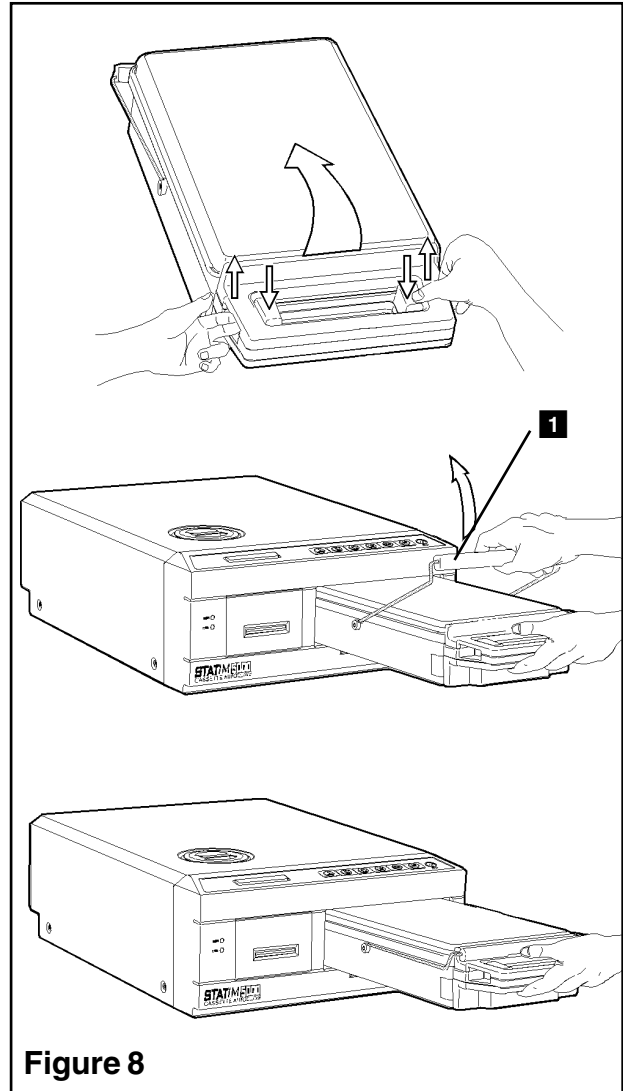

Figure 8



Never push the cassette into the Statim with force as the interior components could be damaged.

4. Instructions For Use Cont'd.

- **Removing the cassette:**

1. Grasp the cassette handle with one hand and pull out from the unit.
2. As the cassette emerges from the unit, grasp the carry handle with your free hand and lift it upwards.
3. Pull the cassette clear from the unit and set down on a firm surface.

- **Disengaging the cassette**



When not in use, the cassette should be disengaged. To disengage the cassette, grasp the handle and pull the cassette out until there is a 15 mm to 20 mm ($\frac{1}{2}$ " to $\frac{3}{4}$ ") gap between the front of the Statim 5000 and the cassette handle.

4.3 Statim 5000 — STAT-DRI Plates

The Statim 5000 cassette uses STAT-DRI plates to enhance the drying process for wrapped instruments. The adjustable plates are designed for the unwrapped instruments rack and eliminate the need for a separate wrapped instrument rack. Up to ten plates can be arranged either along the length of the rack or across the rack. With the exception of the U.S. model, each unit is shipped with five STAT-DRI plates. Additional plates may be ordered from SciCan (SciCan part number 01-103935). To install and adjust a STAT-DRI plate, follow these steps:

1. Hold a plate in the desired orientation, tilted slightly forward with the tabs down.
2. Insert the tabs between the mesh of the unwrapped instrument rack.
3. Each tab has an elongated slot. Slide the plate until the wire is at the end of each slot.
4. Release the plate to the resting position.
5. Prepare and load instruments for sterilization.

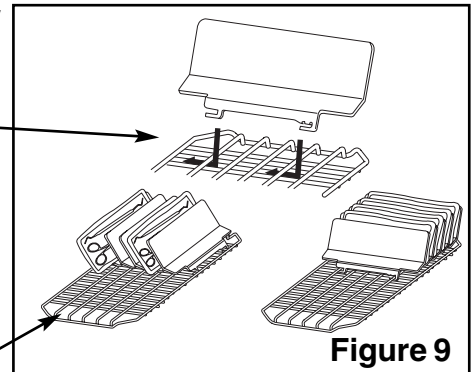

4.4 Preparing and Loading Instruments

Before loading any instruments into the Statim, consult the instrument manufacturer's reprocessing instructions.

- **Clean Instruments**

Clean and rinse all instruments before loading them into the cassette. Disinfectant residues and solid debris may inhibit sterilization and damage the instruments, the cassette, and the Statim. Lubricated instruments must be wiped thoroughly and any excess lubricant should be removed before loading.

4. Instructions For Use Cont'd.



- **Unwrapped Instruments**

Arrange unwrapped instruments on the instrument rack in the tray so that they do not touch one another. This ensures that steam reaches all surfaces and will promote drying.



Instruments must not be stacked or piled in the cassettes, as this will impede the sterilization process.



- **Wrapped Instruments**

Place the instruments into autoclave bags according to the manufacturer's instructions. Orient the instrument rack in the cassette to ensure that wrapped instruments rest approximately 6 mm (0.25 ") above the cassette base. Place the wrapped instruments on the rack and arrange them to avoid overlap. Ensure that all wrapped loads are dry before handling and /or storage to maintain sterility.



The use of cloth wraps in the Statim is not recommended.

SciCan recommends the use of plastic / paper autoclave bags such as SPS™, Medi-Plus™ and Chex All II™. Steri-Stik™ paper / paper may also be used. The use of cloth wraps in the Statim is not recommended. Loosely pack instruments in the bags to allow steam penetration to all instrument surfaces.

The wrapped instrument rack for the Statim 5000 is designed to hold a maximum of 12 autoclave bags. Care must be taken to ensure that the combined weight of the loaded bags does not exceed 1.5 kg (3.3 lbs).

The Unwrapped instrument rack fitted with a maximum of 10 Stat-Dri plates will hold 10 autoclave bags.



- **Rubber and Plastic Instruments**

The following materials can be sterilized in the Statim:

nylon, polycarbonate (Lexan™), polypropylene, PTFE (Teflon™), acetal (Delrin™), polysulfone (Udel™), polyetherimide (Ultem™), silicone rubber, and polyester.



When loading rubber and plastic instruments in the tray, leave a space between the instruments and the cassette walls. This ensures that steam reaches all surfaces, and will promote drying.



The following materials **cannot** be sterilized in the Statim:

polyethylene, ABS, styrene, cellulose, PVC, Acrylic (Plexiglas™), PPO (Noryl™), latex, neoprene, and similar materials.



Use of these materials may lead to instrument or equipment damage. If you are unsure of your instrument's material or construction, do not load into your Statim until you have checked with the instrument manufacturer.

4. Instructions For Use Cont'd.

- **All Instruments**



The Statim is **NOT** intended for sterilizing textiles, liquids or biomedical waste. Unwrapped instruments, once exposed to ambient or external conditions, cannot be maintained in a sterile state. If sterile storage is desired, wrap the instruments to be sterilized in autoclave bags, according to the instrument manufacturer's instructions. Then allow the wrapped cycle to run until the air-dry phase is complete.

Best Practice: Allow instruments (wrapped or unwrapped) to dry completely prior to handling. In order to promote drying and enable effective sterilization, wrapped or pouched instruments must not touch each other.

- **Note for Ophthalmology Use**

In the field of ophthalmology, proper wrapping or pouching of surgical instruments will reduce the exposure of instruments to any process residues during the sterilization cycle. Due to the highly sensitive nature of some types of surgery (particularly in ophthalmology), SciCan recommends that all instruments be routinely packaged or wrapped and processed through the wrapped cycle of the sterilizer. This practice is the suggested approach for the majority of sterile surgical procedures and is referenced in most leading infection control publications and guidelines.

- **Routine Monitoring**

Chemical process indicators suitable for steam sterilizers should be included in or on each package or load being sterilized. In addition, the weekly use of biological indicators, which allow you to ascertain whether the instruments have been exposed to sterilization conditions, is recommended. For Statim 5000 units in the United States, SciCan recommends using the 3M Attest™ biological monitoring system for routine monitoring. This system consists of self contained biological indicators and incubators. It is important to select the correct biological indicator for the cycle being tested.

4. Instructions For Use Cont'd.

For detailed instructions on how to handle, use and dispose of both the biological and chemical indicators, please consult the product literature accompanying the 3M Attest™ biological indicators or contact the manufacturer directly.

To use the indicators with the Statim, follow these steps:

1. Place the appropriate biological indicator in the Statim chamber.
2. Process the load in the sterilizer according to your usual practice.
3. Ensure that the message “Cycle Complete” is displayed on the LCD after the cycle is finished.
4. Recover the biological and / or chemical indicator and process further according to the literature that accompanied the indicator.

At the first indication of a potential sterilization failure:

1. Do not process any more instruments until favourable test results have been returned.
2. Ensure the correct indicator type was chosen.
3. Ensure the cassette was not overloaded. Consult the earlier portion of this section for proper loading instructions.
4. If the results do not change, do not process any more instruments within the Statim and contact your SciCan dealer for further assistance.

Because the turnaround time for the 3M Attest™ is up to 48 hours, it is recommended that the tests be conducted so that the incubation period occurs during a period of planned downtime such as the last cycle before a weekend.

4.5 Instrument Mass Guide

Instrument	Typical Instrument Mass
Scissors	30 g (0.96 ozt)
Dental scalers	20 g (0.64 ozt)
Forceps	15 g (0.48 ozt)
Dental handpiece	40 to 60 g (1.3 ozt to 1.9 ozt)
Wrapped Instrument rack	260 g (8.36 ozt)
Unwrapped instrument rack	225 g (7.23 ozt)
Suction cannula	10 g (0.32 ozt)
Plastic mouth mirror	8 g (0.3 ozt)
Impression tray	15 to 45 g (0.48 ozt to 1.5 ozt)
Plastic x-ray positioning ring	20 g (0.64 ozt)

NOTE: The above weights are to be used as reference only. For exact weights of your instruments, consult the manufacturer's specifications.

4. Instructions For Use Cont'd.

4.6 Statim 2000 — Selecting a Cycle

The Statim 2000 has three sterilization cycles, each designed to sterilize a specific type of instrument. The instruments will remain sterile after a successful cycle until the cassette is removed from the autoclave. At the end of each sterilization cycle, microbiologically filtered air-drying will commence for 1 hour. Air-drying can be interrupted at any time.

Unwrapped instruments, once exposed to ambient or external conditions, cannot be maintained in a sterile state. If sterile storage is desired, wrap the instruments to be sterilized in autoclave bags, according to the instrument manufacturer's instructions, then allow the wrapped cycle to run until the air-dry phase is complete.

The types of instruments, sterilization requirements, and a graph depicting each cycle are described over the next few pages. Consult the Instrument Mass Guide in Section 4.5 for information on how to make up an appropriate load for the masses specified for individual cycles.



1. Unwrapped Cycle

The Unwrapped Cycle is a general purpose sterilization cycle used to sterilize up to 1.0 kg (2.2 lbs) of solid metal instruments such as pliers, burs, scalers and forceps. Dental handpieces may be sterilized in this cycle.

To select the Unwrapped Cycle, press the Unwrapped Cycle button, then press the **START** button.

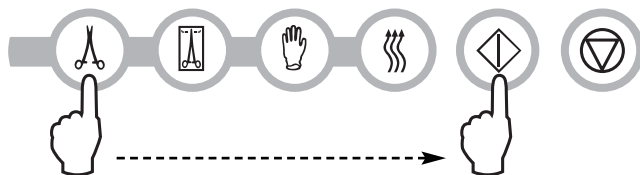

The sterilization temperature in the cassette is 135 °C (275 °F) and the holding time is 3.5 minutes. See Section 4.1 Statim 2000 — Using the Cassette and Section 4.4 Preparing and Loading Instruments before running this cycle.

*See the chart at the end of section 4.7 Statim 2000 - Running a Cycle for a complete list of cycle time and temperature listings in different countries.

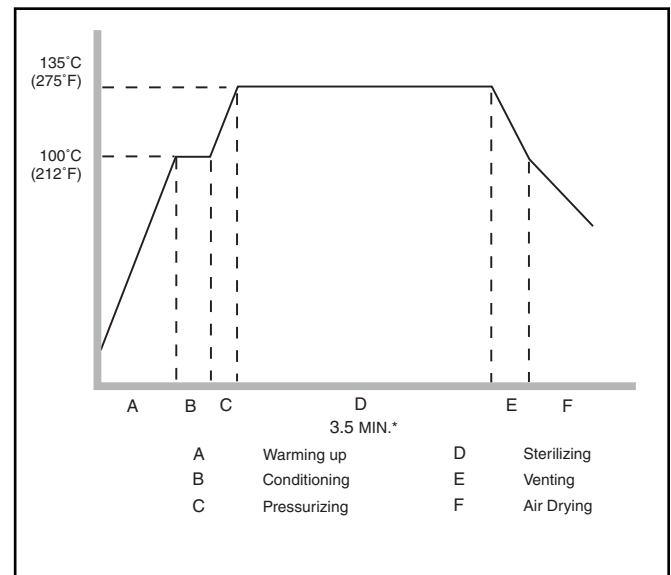

4. Instructions For Use Cont'd.



2. Wrapped Cycle

The Wrapped Cycle is used to sterilize up to 1.0 kg (2.2 lbs) of solid and hollow metal instruments which have been sealed in paper / paper, or paper / plastic autoclave bags. Dental handpieces may be sterilized in this cycle.

To select the Wrapped Cycle, press the Wrapped Cycle button, then press the **START** button.

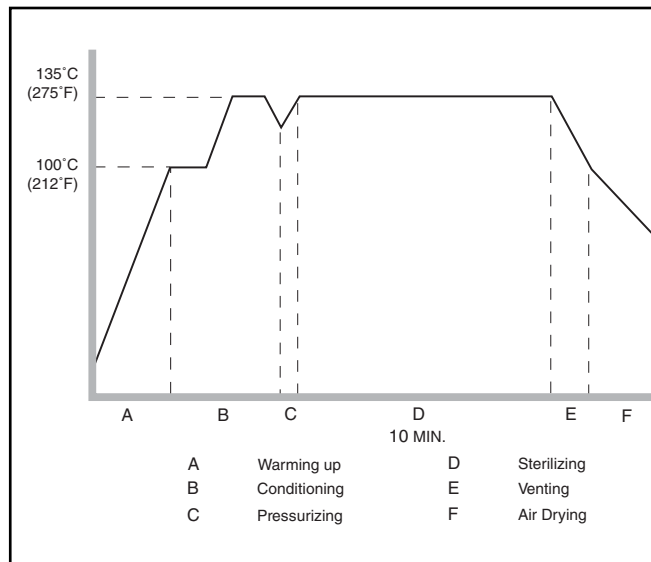
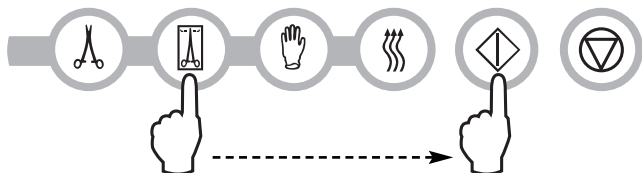

The sterilization temperature in the cassette is 135°C (275°F) and the holding time is 10 minutes. See Section 4.1 Statim 2000 — Using the Cassette and Section 4.4 Preparing and Loading Instruments before running this cycle.



If wrapped instruments are intended for storage, the wraps must be dry when the cassette is removed from the unit and opened.



3. Rubber and Plastics Cycle

The Rubber and Plastics Cycle is used to sterilize up to 0.4 kg (0.9 lbs) of solid unwrapped instruments constructed of metal or the materials listed in Section 4.4 Preparing and Loading Instruments. To select the Rubber and Plastics Cycle, press the Rubber and Plastics Cycle button, then press the **START** button.

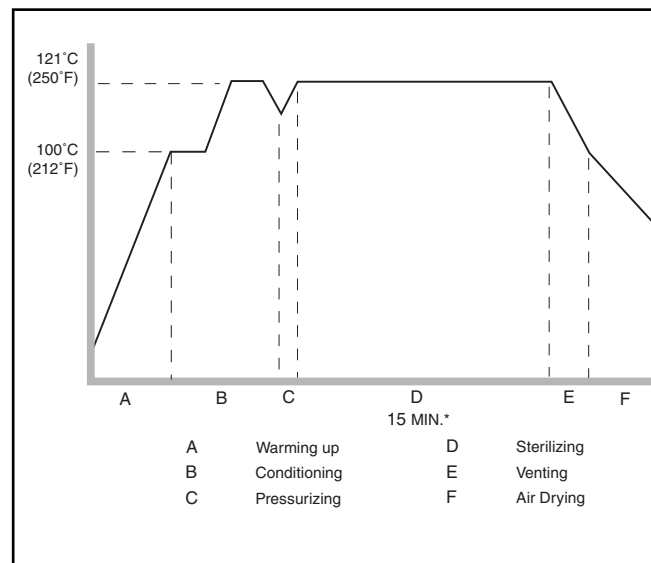

The sterilization temperature in the cassette is 121°C / 250°F and the holding time is 15 minutes.

*See the chart at the end of section 4.7 Statim 2000 - Running a Cycle for a complete list of cycle time and temperature listings in different countries.

4. Instructions For Use Cont'd.



4. Air Dry Only Cycle

This is not a sterilization cycle.



The Air Dry Only Cycle starts automatically after each sterilizing cycle and runs for 60 minutes.

Air drying may be interrupted by pressing the **STOP** button. To ensure that the contents of the cassette are dry, the cycle should run for the full 60 minutes. Dryness is important for unwrapped instruments for corrosion prevention. For wrapped instruments, a dry wrap is required to maintain sterility.

If the **STOP** button is pressed during the air drying stage of the sterilization cycle, and the cassette has not been removed from the autoclave, the Air Dry Only cycle may be used to promote further drying. If the cassette has been removed from the autoclave, it may **NOT** be reinserted for the Air Dry Only cycle. If the cassette contains wrapped instruments and the wraps are not dry when the cassette is opened, the instruments must be used immediately or resterilized.

To start, press the Air Dry Only cycle button, then press the **START** button.

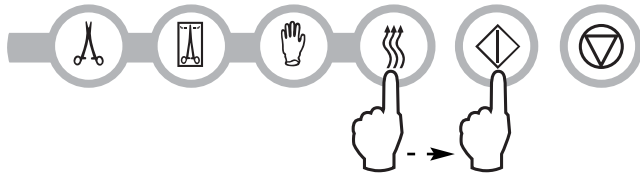

When started independently, this cycle will run for 1 hour.

4. Instructions For Use Cont'd.

4.7 Statim 2000 — Running a Cycle

To operate each cycle, follow these steps and watch the LCD .

Turn the power switch at the back of the unit to **ON**.
The LCD Display reads:

SELECT A CYCLE

or

14:23 3/11/2001
SELECT A CYCLE

(if optional printer is installed)

Press the appropriate cycle button on the keypad.



The display will read either:

UNWRAPPED
135°C for 3.5 min*.

or

WRAPPED
135°C for 10 min.

or

RUBBER AND PLASTICS
121°C for 15 min*.

* See the chart at the end of section 4.7 Statim 2000 - Running a Cycle for a complete list of cycle time and temperature listings in different countries.

As the button is released the display reads:

[CYCLE YOU SELECTED]
PRESS **START**



The amber indicator light comes on to indicate that the cycle is in progress. During the cycle, the phases of the cycle will be displayed and the messages will appear similar to:

[CYCLE YOU SELECTED]
WARMING UP

CONDITIONING
95°C

PRESSURIZING
130°C

STERILIZING
135°C 212kPa 3:30

VENTING
105°C

4. Instructions For Use Cont'd.

As the cycle is running an intermittent buzzing sound will be apparent as the pump injects water into the steam generator. A random clicking sound will also be heard as the exhaust valve opens and closes.

Once the sterilization cycle is complete, a reminder tone will sound and the amber light will flash as the cycle moves into the Air Drying phase.

The buzzing noise during the air drying stage is the compressor operating. The air drying phase of the cycle may be interrupted at any time by pressing the **STOP** button. The display will appear similar to:

[CYCLE YOU SELECTED]
REMOVE CASSETTE

When the automatic 60 minute air drying stage is finished the display reads:

[CYCLE YOU SELECTED]
CYCLE COMPLETE

If a sterilization cycle is successful the reminder tone sounds and the amber light flashes until the **STOP** button is pressed or the cassette is removed from the unit.

If a message is displayed which gives a CYCLE FAULT code or a NOT STERILE message, the cassette contents are not sterile. See Section 6. Troubleshooting for more information.

* Statim 2000 Cycle Time, Temperature, and Model Listing

Country	Model no.	Unwrapped		Wrapped		Rubber & Plastics	
		Temp	Time	Temp	Time	Temp	Time
Czech	01-122328	135°C 275°F	4 min.	135°C 275°F	10 min.	121°C 250°F	20 min.
Canada (and all other Countries)	All other models	135°C 275°F	3.5 min.	135°C 275°F	10 min.	121°C 250°F	15 min.

4. Instructions For Use Cont'd.

4.8 Statim 5000 — Selecting a Cycle

The Statim 5000 has four sterilization cycles, each designed to sterilize a specific type of instrument. It is important not to overload the chamber as this can inhibit steam access to all instrument surfaces. The instruments will remain sterile after a successful cycle until the cassette is removed from the autoclave housing. At the end of each sterilization cycle, microbiologically filtered air-drying will commence for 1 hour. Air-drying can be interrupted at any time.

Unwrapped instruments, once exposed to ambient or external conditions, cannot be maintained in a sterile state. If sterile storage is desired, wrap the instruments to be sterilized in autoclave bags, according to the instrument manufacturer's instructions, then allow the wrapped cycle to run until the air-dry phase is complete.

The types of instruments, sterilization requirements, and graphs depicting each cycle are described on the next few pages. Consult the Instrument Mass Guide in section 4.5 for information on how to make up an appropriate load for the masses specified for individual cycles.



Please note that not all cycle times are standard with all units. See the chart at the end of Section 4.9 Running a Cycle for a complete list of all Statim 5000 cycle times and temperatures.

4. Instructions For Use Cont'd.



1. Unwrapped Cycle

The Unwrapped Cycle is used to sterilize light loads (less than 0.5 kg or 1.1 lbs) of solid metal instruments such as pliers, burrs, scalars, and forceps.

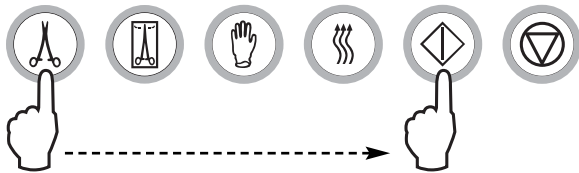

To select the Unwrapped Cycle, press the Unwrapped Cycle button, then press the **START** button. The sterilization temperature in the cassette is 135° C* (275° F*) and the holding time is 3.5 minutes*. See Section 4.2 Statim 5000 — Using the Cassette and Section 4.4 Preparing and Loading Instruments before running this cycle.

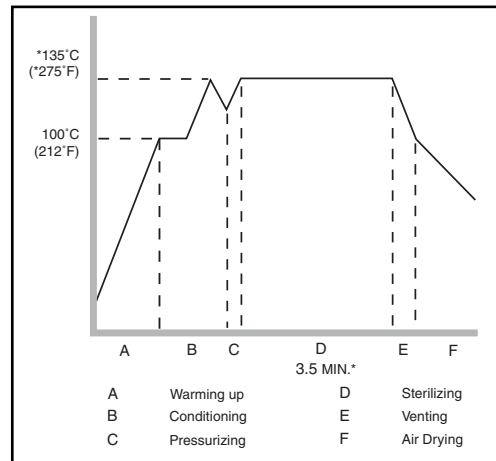

* See the chart at the end of Section 4.9 Statim 5000 — Running a Cycle for a complete list of cycle time and temperature unit listings in different countries.



2. Wrapped Cycle

The Wrapped Cycle is used to sterilize up to 1.5 kg (3.3 lbs) of solid and hollow metal instruments which have been sealed in paper / paper, or paper / plastic autoclave bags. Dental hand pieces may be sterilized in this cycle.

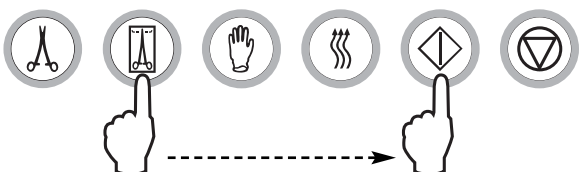

To select the Wrapped Cycle, press the Wrapped Cycle button, then press the **START** button. The sterilization temperature in the cassette is 135° C* (275° F*) and the holding time is 6 minutes*. See section 4.2 Statim 5000 — Using the Cassette and Section 4.4 Preparing and Loading Instruments before running this cycle.

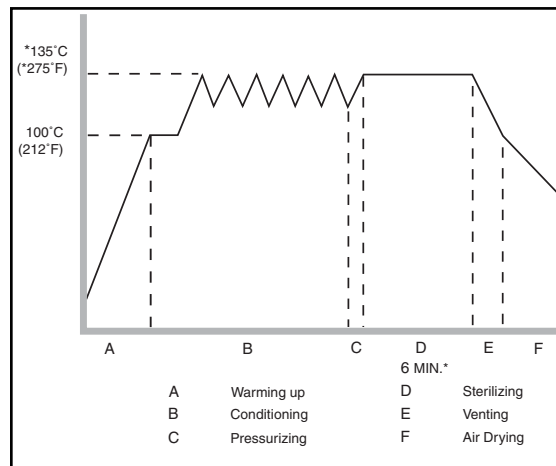

* See the chart at the end of Section 4.9 Statim 5000 — Running a Cycle for a complete list of cycle time and temperature unit listings in different countries.



If wrapped instruments are intended for storage, the wraps must be dry when the cassette is removed from the unit and opened.

4. Instructions For Use Cont'd.



3. Rubber and Plastics Cycle

The Rubber and Plastics Cycle is used to sterilize up to 0.4 kg (0.9 lbs) of solid or hollow unwrapped instruments constructed of metal or the materials listed in Section 4.4 Preparing and Loading Instruments.

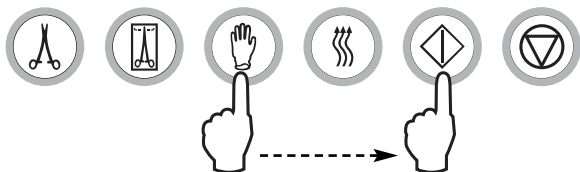

To select the Rubber and Plastics Cycle, press the Rubber and Plastics Cycle button, then press the **START** button. The sterilization temperature in the cassette is 121 °C (250 °C) and the holding time is 15 minutes*.

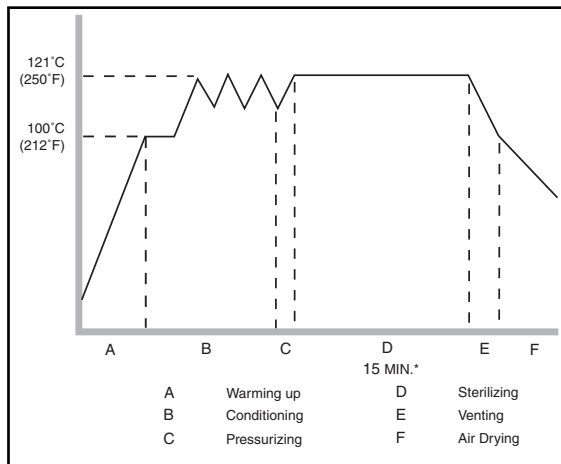

- * See the chart at the end of Section 4.9 Statim 5000 — Running a Cycle for a complete list of cycle time and temperature unit listings in different countries.

4. Heavy Duty Unwrapped Cycle

The Heavy Duty Cycle is used to sterilize larger loads of unwrapped metal instruments weighing up to 1.5 kg (3.3 lbs). Dental hand pieces can be sterilized in this cycle.

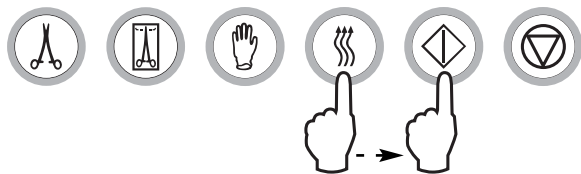

To select the Heavy Duty Unwrapped Cycle, press the Heavy Duty Unwrapped Cycle button, then press the **START** button.

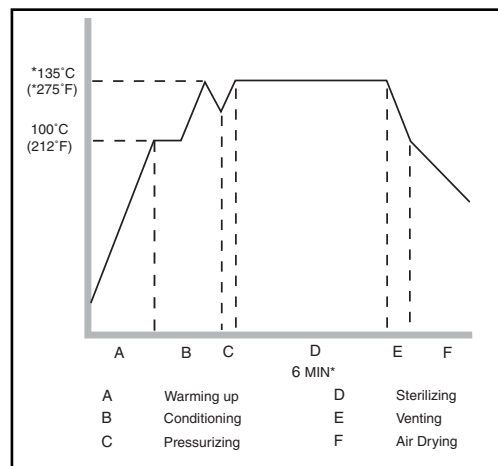

- * See the chart at the end of section 4.9 Statim 5000 — Running a Cycle for a complete list of cycle time and temperature unit listings in different countries.

4. Instructions For Use Cont'd.

4.9 Statim 5000 — Running a Cycle

See the chart on the end of section 4.9 Statim 5000 — Running a Cycle for a complete list of cycle time and temperature unit listings in different countries. To operate each cycle, follow these steps and watch the LCD.

Turn the power switch at the back of the unit to **ON**.
The LCD Display reads:

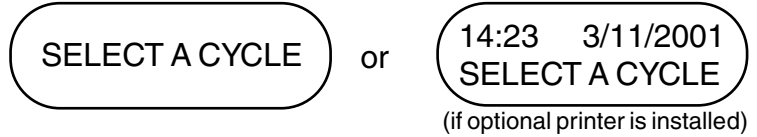

Press the appropriate cycle button on the keypad.



The display will read either:

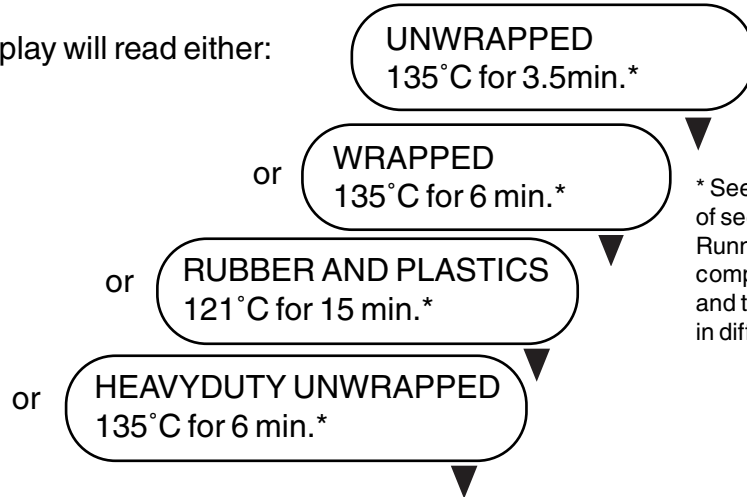

* See the chart on the end of section 4.9 Statim 5000-Running a Cycle for a complete list of cycle time and temperature unit listings in different countries.

As the button is released the display appears similar to:

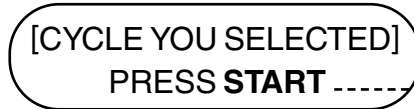

The amber indicator light comes on and the display will appear similar to:

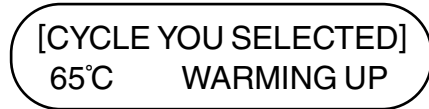

As the cycle progresses, the cycle stage and temperature of the chamber are displayed.



During sterilization, the pressure of the chamber and the time remaining for that stage is also displayed. During the air drying phase, the time remaining is displayed.



4. Instructions For Use Cont'd.

The sterilizing cycle ends when the reminder tone sounds, the amber light flashes and the message CYCLE COMPLETE is displayed. The display appears similar to:



You may interrupt the automatic 60 minute Air Drying phase at any time, or let it run to the end. To ensure that Wrapped Instrument loads are dry, allow this cycle to run to be completed. **Instruments in wrapped packs should be considered non-sterile if removed before the end of the drying phase.**

To remove the cassette, you must first press the  button on the keypad.

The display appears similar to:

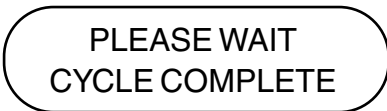

Be careful. The metal parts will be hot, and the cassette will contain hot steam. After the cassette is removed from the unit, it should be opened to hasten drying of unwrapped instruments.

If the Air Drying phase is not interrupted, the program will automatically continue to run. When this phase ends, the display reads:

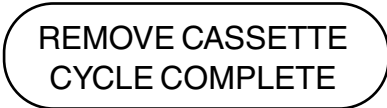

When a sterilization cycle is successful, the reminder tone sounds and the amber light flashes until the STOP button is pressed or the cassette is removed from the unit.

If a message is displayed which gives a CYCLE FAULT code or a NOT STERILE message, the cassette contents may not be sterile. See Section 6. Troubleshooting for more information.

* Statim 5000 Cycle Time, Temperature, and Model Listing

Country	Model no.	Unwrapped		Wrapped		Rubber & Plastics		Heavy Duty Unwrapped	
		Temp	Time	Temp	Time	Temp	Time	Temp	Time
USA	01-201103(-R)	132°C	3.5	132°C	6	121°C	35	132°C	6
	01-201104(-R)	270°F	min.	270°F	min.	250°F	min.	270°F	min.
Czech Republic	01-202327	135°C	4	135°C	10	121°C	20	135°C	18
	01-202328	275°F	min.	275°F	min.	250°F	min.	275°F	min.
	01-212328								
Canada (and all other Countries)	All other models	135°C	3.5	135°C	6	121°C	15	135°C	6
		275°F	min.	275°F	min.	250°F	min.	275°F	min.

4. Instructions For Use Cont'd.

4.10 Stopping a Cycle

To stop a cycle press the **STOP** button. If the stop button is pushed, the cassette is removed, or the unit detects a problem while operating the cycle will stop and the amber active light will flash. Once a cycle has been interrupted, the **STOP** button must be pressed before another cycle can be started. The display reads any of the following messages:

CYCLE FAULT # #
NOT STERILE

or

CASSETTE REMOVED
NOT STERILE



If the display shows the message, CYCLE FAULT or NOT STERILE, the cassette contents are not sterile! See section 6. Troubleshooting for more information.

If the air drying stage of the cycle is interrupted, do not store wrapped instruments that were in the cassette unless they are dry.

5. Maintenance

5.1 Cleaning the Cassette

Keeping the Statim cassette clean is good clinical practice and assists in the function of the unit. SciCan recommends that the interior surface be cleaned at least once a week. Use dishwashing soap or a mild detergent that does not contain chlorine. Scrub the inside of the cassette with a cleaning pad designed for use with Teflon™ coated surfaces. After scouring, rinse thoroughly with water to remove all traces of the detergent. Cleaning the inside of your cassette is very important if you regularly sterilize lubricated instruments. Coating the entire inside surface with STAT-DRI / STAT-DRI PLUS drying agent induces water to form an even coat on the inside surface, without beading. The water in contact with the hot cassette surfaces also evaporates much more efficiently. Spotting is minimized and instruments dry much better. STAT-DRI / STAT-DRI PLUS should be applied every 10 cycles, and after every cassette cleaning.

5.2 Cleaning the Reservoir

Check the reservoir for dirt or particles. The reservoir may be cleaned by draining followed by cleaning and rinsing with steam process distilled water ONLY. Use of chemicals or cleaning agents is not recommended and could cause the unit damage.

5.3 Cleaning the Exterior Surfaces

Use a soft cloth moistened with soap and water to clean all exterior surfaces. Do not use harsh cleaning chemicals or disinfectants.

5.4 Changing the Statim 2000 Air Filter

The filter should be replaced every six months in order to maintain an adequate supply of clean air during the air drying cycle.

To change the filter, follow these steps:

1. Turn the power switch at the back of the unit **OFF**.
2. Remove and discard the old foam air filter **4**.
3. Install the new filter **4** (SciCan part no. 01-100207S).
4. Secure the filter plate **2** to the back of the compressor using the screw **1** retained during the disassembly procedure.

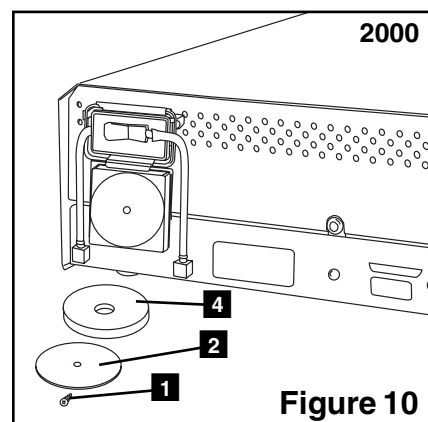

5. Maintenance Cont'd.

5.5 Changing the Bacteria Retentive Air Filters

The filters should be replaced every six months or after 500 cycles to maintain an adequate supply of clean air during the air drying cycle.

To change the bacteria retentive air filter on the Statim 2000 and 5000, follow these steps:

1. Power the Statim **OFF**.
2. Disconnect tube A **1** from the bacteria retentive filter **2** and remove the filter from the filter bracket **3**. As you remove the filter from the bracket, note the orientation of the arrow mark on the filter.
3. When the filter is free of the bracket, carefully disconnect tube B **4** from the filter.
4. Before installing the replacement bacteria retentive filter **2** (SciCan order no. 01-102119S) check that the arrow mark on the filter matches the direction of the arrow on the bracket. Push the left hand filter fitting into tube B **4**.
5. Gently press the replacement filter into the filter bracket **3**. The arrow mark of the filter should be facing out and pointing to the left.
6. Re-connect tube A **1** to the right hand filter fitting.

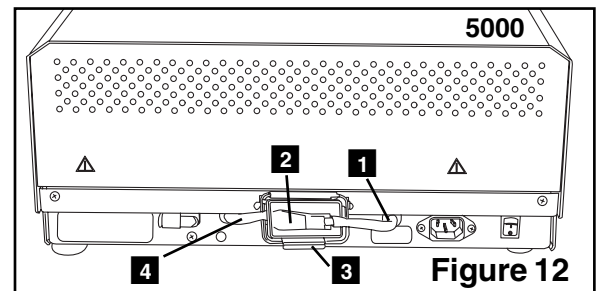
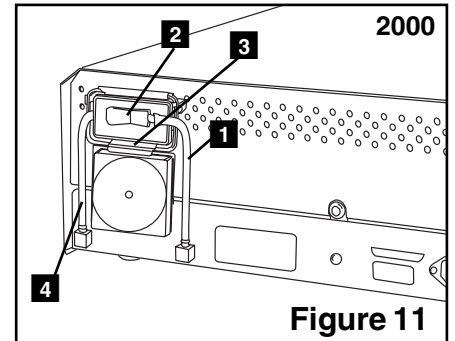

5.6 Replacing the Cassette Seal

To ensure optimum performance of your Statim cassette autoclave, change the cassette seal every 500 cycles or every six months, whichever comes first. Replacement seals are available from SciCan (order number 01-100028S for Statim 2000 and 01-101649S for Statim 5000).

When replacing the cassette seal, the cassette channel must be flushed with distilled water. The old seal is removed, the cassette channel is flushed with distilled water and then followed by replacement with the new seal.

5. Maintenance Cont'd.

To change the cassette seal, follow these steps:

Place the cassette lid and the new seal on a clean work surface. Examine the position of the old seal in the cassette lid and arrange the new seal in the same orientation, next to the lid.

Remove the old seal and discard. Clean any residue out of the seal channel and flush out the channel with distilled water.

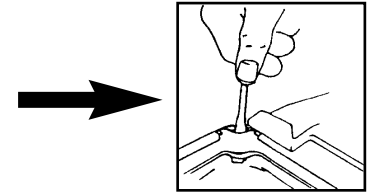

Lubricate the new seal with the liquid seal lubricant provided.

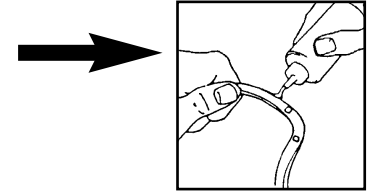

Insert the rounded edge of the seal under the round lip of the lid. Align the holes in the new seal with the holes in the lid.

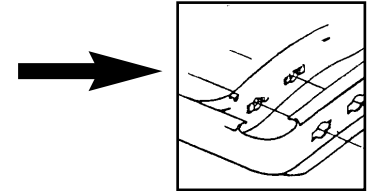

NOTE: At every corner, two square nibs should be visible.

Ensure the seal is completely inserted. Feel around the periphery to ensure the seal is securely in place.

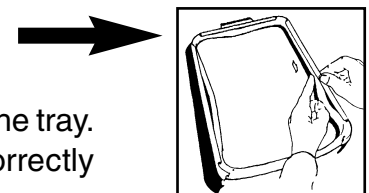

NOTE: During a cycle, steam may appear between the lid and the tray. If this persists, remove the cassette and check that the seal is correctly installed.

Figure 13



Be careful. The metal parts will be hot, and the cassette may contain hot steam.

5.7 Maintaining Fluid Levels

Use only steam-process distilled water containing less than 5 ppm total dissolved solids (having conductivity of less than 10 $\mu\text{S}/\text{cm}$) in the Statim. To fill the reservoir, remove the cap from the top of the unit and fill the reservoir. We recommend using a funnel to minimize spills. Each time you refill the reservoir, empty the waste bottle and refill with water to the MIN line. Empty the waste often to avoid unpleasant odors and discoloration of the contents. (A low-level chlorine-free disinfectant, prepared according to the manufacturer's instructions, may be added to the waste bottle to remedy this situation).

5.8 Preventative Maintenance Schedule



To ensure trouble-free performance, both the operator and the dealer must follow a preventative maintenance schedule.

NOTE: Please refer to your National, Regional, State or Safety laws for any additional reoccurring user testing that may be required.

5. Maintenance Cont'd.

The schedules below describes the necessary actions.

Operator		
Daily	Cassette	Wash the interior of the cassette with chlorine-free dishwashing detergent or soap. Rinse thoroughly with water.
	Unit	To ensure optimal performance of the Statim autoclave, SciCan recommends that a full sterilization cycle, which must include the full Air Drying phase, be completed at the end of each day of use. This is especially important when the unit is left idle over the weekend or for any extended period of time.
	Water Reservoir	Drain Daily
	Waste Bottle	Empty the waste bottle every time you refill the reservoir. Fill with tap water up to MIN line. You can also add some chlorine-free disinfectant.
Weekly	Air Filter	Check the air filter for dirt and moisture. Replace if dirty. Call for service if wet.
	Biological Air Filter	Check the air filter for dirt and moisture. Replace if dirty. Call for service if wet.
Every six months	Air Filter	Replace every 500 cycles or six months (whichever comes first).
	Biological Air Filter	Replace every 500 cycles or six months (whichever comes first).
	Cassette Seal	Replace every 500 cycles or six months (whichever comes first).



Technician		
Once a year	Cassette	Check the tray, lid and seal for damage. Replace if necessary.
	Air Filters	Check the filters. Replace if dirty.
	Solenoid Valve	Inspect the valve and clean if dirty. Replace the plunger if defective.
	Pump	Clean the filters, replace if dirty.
	Check Valve	Remove the air compressor tube from the check valve inlet while running a cycle. Make sure no steam is leaking from the valve. Replace if there are any leaks.
	Water Reservoir	Check the reservoir for dirt. Clean and rinse with steam process distilled water if necessary.
	Calibration	Calibrate the unit.

5. Maintenance Cont'd.



5.9 Spare Parts List

01-100780S	Bumper	01-101709S	Mesh Rack, (5000)
01-100782S	Push-in Fitting, (2000)	01-101757S	Cassette Lid w/Box, (5000)
01-101658S	Cassette Handles, (5000)	01-101763S	Power Cord Japan, (2000 & 5000)
01-101755S	Push-in Fitting, (5000)	01-101766S	Power Cord UK, (2000 & 5000)
01-106030S	Cassette Lid Handle, (2000)	01-101767S	Power Cord Australia, (5000)
01-104472	Extended cassette Handles	01-101768S	Power Cord Switzerland, (2000 & 5000)
01-100008A	Kit Cassette Final (2000)	01-101769S	Power Cord Italy, (2000 & 5000)
01-100028S	Cassette Seal, (2000)	01-101779S	Power Cord Europe, (2000 & 5000)
01-100204S	Exhaust Tube, (2000 & 5000)	01-101783S	Reservoir Cap, (2000 & 5000)
01-100207S	Compressor Filter	01-101787S	Filler Cap (Demo), (2000 & 5000)
01-100271A	Kit Tray Cassette w/Mesh, Box Stat1	01-101970S	Data Cable, (5000 and STATprinter)
01-100572S	Power Cord North America, (2000)	01-101974	STATprinter
01-100584S	Power Cord German, (2000)	01-102054S	Rack-Wrapped Instruments, (5000)
01-100585S	Power Cord Italian, (2000)	01-102119S	Filter Biological, (2000 & 5000)
01-100586S	Power Cord U.K., (2000)	01-103139S	Conductivity Meter, (2000 & 5000)
01-100612S	English Manual/Tubing/Indicators, (2000)	01-103475S	Tray, (2000)
01-100724S	Condenser Bottle w/o Condenser, (2000 & 5000)	01-103555S	Power Cord Replacement Denmark
01-100730S	Power Cord Japan, (2000)	01-103557S	Power Cord Replacement Denmark (detached)
01-100735S	Waste Water Bottle Fitting, (2000 & 5000)	01-103865S	Seal Lubricant, (2000 & 5000)
01-100783S	Kit Filler Cap Replacement Eng.	01-103923	Condenser Additional Bottle
01-100799S	Power Cord Switzerland, (2000)	01-103935	STATDRI Plates, (5000)
01-100812S	Condenser Bottle, (2000 & 5000)	01-103945S	Rack-Tray Unwrapped Instrument Kit, (2000)
01-100834S	Cassette Lid, (2000)	01-104093S	Exhaust Tube 3m Long
01-101553S	Leveler, (2000 & 5000)	01-104104	Extended Length Cassette, (5000)
01-101613S	Cassette Complete with Box, (5000)	01-104284S	Biological Filter Bracket, (2000 & 5000)
01-101614S	Tray Complete with Box, (5000)	01-104337S	Extended Evaluation Cassette, (5000)
01-101647S	Power Cord North America, (5000)	01-104343S	Plug - Drain Tubing, (5000)
01-101649S	Cassette Seal, (5000)	01-104499	Extended Cassette Instrument Rack, (5000)
01-101652S	Air Compressor Filter, (5000)	01-104785S	Instrument Holder - 10 mm, (5000)
01-101657S	Thermal Paper (Box of 10 rolls)	01-104786S	Instrument Holder - 4 mm, (5000)

6. Troubleshooting

Problem	Solution
<p>Unit does not power ON.</p>	<p>Check that the unit is plugged into a properly grounded outlet and that the power cord is firmly seated at the rear of the machine.</p> <p>Try another circuit. Power unit OFF for 10 seconds and then power ON again.</p> <p>Check the condition of the line circuit breaker or fuse.</p>
<p>There is water under the machine.</p> <div style="text-align: center;">   </div>	<p>Check that water was not spilled when refilling the reservoir. Make sure the plug in the drain tube is secured. Remove and reinsert the cassette . Attempt another cycle.</p> <p>Be careful. The metal parts will be hot, and the cassette will contain hot steam.</p> <p>The cassette is leaking. If water drips from the underside of the unit during operation, check the cassette seal for misalignment or damage and replace the seal if required.</p> <p>Be careful. The metal parts will be hot, and the cassette will contain hot steam.</p> <p>Attempt another cycle. If it still leaks attempt another cycle using a different cassette if possible.</p> <p>If the leak persists, turn the unit OFF, remove and unload the cassette, unplug the unit, and call your dealer.</p>
<p>Instruments do not dry.</p>	<p>Best drying occurs when the cycle continues to completion. Allow the cycle to finish. Make sure the instruments are loaded correctly in the cassette. Refer to section 4.4 Preparing and Loading Instruments.</p> <p>Check the unit leveling.</p> <p>Check air filters and replace if dirty.</p> <p>Clean the inside of the cassette and treat with Stat-Dri / Stat-Dri Plus drying agent. Refer to section 5.1 Cleaning the Cassette.</p> <p>Examine the exhaust tube (tube to the waste bottle) for kinks.</p>

6. Troubleshooting Cont'd.

	<p>If kinked, straighten the tube. If the tube cannot be straightened, remove it from the push-in fitting attached to the Statim. Depress the collar on the fitting and with the other hand pull firmly on the tube. Once the tube is free of the fitting, cut the damaged section of tubing away using a sharp instrument. Be sure that you leave enough tube to reach the unit when you re-attach the tube to the exhaust fitting. If the tube is too short to remove a section, contact your SciCan dealer for a replacement (Part No. 01-100204S).</p> <p>Make sure the compressor is working. To check, remove the exhaust tube from the waste bottle during the Air Drying phase of a cycle. Wear gloves to do this as the tubing, fittings, and waste bottle will be hot. Place the free end into a glass of water. If there is not a strong, steady flow of bubbles, the compressor is not functioning properly. Contact your SciCan dealer.</p>
<p>Cycle aborted, NOT STERILE and CYCLE FAULT messages.</p> 	<p>Record the CYCLE FAULT number. Wait a few minutes and attempt another cycle before proceeding to the next solution. If the problem persists remove the cassette. Be careful. The metal parts will be hot and the cassette will contain hot steam. Inspect the cassette to ensure that the holes in the back of the seal are perfectly aligned, and that the flexible lip of the seal is completely free. Check the exhaust tube for kinks or obstructions. If kinked, straighten the tube. If the tube cannot be straightened, remove it from the push-in fitting attached to the Statim. Depress the collar on the fitting and, with the other hand pull firmly on the tube. Once the tube is free of the fitting, cut the damaged section of tubing away using a sharp instrument. Be sure that you leave enough tube to reach the unit when you re-attach the tube to the exhaust fitting. If the tube is too short to remove a section, contact your SciCan dealer for a replacement (Part No. 01-100204S).</p> <p>Check that the Statim has not inadvertently been exposed to any electrical interference. Refer to the Installation Section 3.1 Environmental Considerations, for details.</p> <p>Try running another cycle. If the problem persists, record the cycle fault message number and contact your dealer.</p>

6. Troubleshooting Cont'd.

<p>Excessive steam issuing from the front of the machine.</p> 	<p>Remove and reinsert the cassette. Attempt another cycle. If the problem persists remove and check the cassette seal for misalignment or damage. Replace the seal if required. Be careful as the metal parts will be hot and the cassette will contain hot steam.</p> <p>If the leak persists, turn the unit OFF, remove and unload the cassette and contact your SciCan dealer.</p>
<p>Message WATER QUALITY IS NOT ACCEPTABLE. Machine will not start.</p>	<p>You have used water which is not steam-process distilled or is improperly distilled.</p> <p>Empty the reservoir and refill with steam-process distilled water containing less than 5ppm total dissolved solids (having conductivity of less than 10 $\mu\text{S/cm}$). If you have the water conductivity meter, check the quality of the water before refilling the reservoir. Refer to the steps described in Section 3.8 Shipping the Unit to empty the reservoir.</p>
<p>Message REFILL RESERVOIR, Machine will not start.</p>	<p>The level of the water in the reservoir is low. Refill the reservoir. Refer to the steps described in Section 3.4 Filling the Reservoir.</p>
<p>Message PRINTER FAULT displayed on LCD Printer is not printing.</p>	<p>Check for a paper jam. If the paper is jammed, follow the paper removal procedures outlined in the following section. Power unit OFF for 10 seconds and then power ON again. If the paper is still jammed, follow the disassembly procedures outlined in Section 7.5 Removing Paper Jams.</p>
<p>The printer does not work.</p>	<p>Make sure that the printer cable is connected securely with the connector on the back of the Statim 2000 and the Statprinter.</p> <p>Make sure that the printer is powered ON. Power unit OFF for 10 seconds and then power ON again.</p>
<p>The printer appears to work, but nothing is printed on the paper.</p>	<p>Ensure that the paper is loaded properly (refer to Section 7.4 Installing paper into the Statprinter). Check to see that the paper leaves the paper roll from the top of the roll. This means that the treated surface of the coated thermal paper will be in contact with the thermal print head.</p>
<p>Time and date are incorrect.</p>	<p>The time and date have not been set. See Section 7.3 Setting the Time and Date.</p>

7. The Optional Statprinter

7.1 The Statprinter

For the Statim 2000, the Statprinter is an easily installed stand-alone unit.



Please note that the Statprinter can only be connected to a Statim 2000 Autoclave. Connection to another device may result in damage to the Statprinter, the other device, or both. Also, the Statim 2000 should not be connected to any other printer as this will result in damage to the unit.

The optional Statprinter for the Statim 5000 is a built-in unit that can be specified when ordering your sterilizer, or can be installed later by a technician.

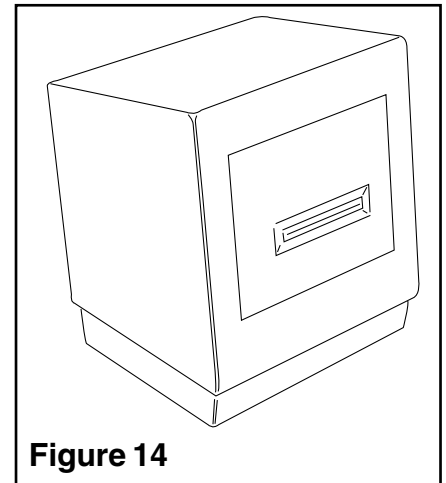

Figure 14

7.2 Installing the Statprinter

When connecting the Statprinter, or any of the cables, ensure the Statim 2000 is powered **OFF**. To install the printer, follow these steps:

1. Remove the Statprinter and printer cable from the packaging.
2. Power the Statim 2000 **OFF**.
3. Connect one end of the printer cable to the Statim 2000 and the other to the connector on the back of the Statprinter. Tighten the screws on the cable connectors.
4. Power the Statim 2000 back **ON**.
5. Open the printer door by pushing the top half of the door inward.
6. Turn the printer **ON**. The Statim 2000 will automatically recognize the printer and will function accordingly.

7.3 Setting the Time and Date

The time and date feature is available with the optional printer only. To set the time and date, follow these steps and watch the blinking cursor on the LCD:

1. Power the Statim **OFF**.
2. For Statim 2000, press and hold the Unwrapped cycle button. For Statim 5000, press and hold the Wrapped cycle button.
3. While pressing the appropriate cycle button, power the Statim **ON**. The LCD display reads:

14:23	12/04/2002
HH:MM	DD/MM/YY

7. The Optional Statprinter Cont'd.



4. Use the cycle buttons to select and change the selected field's value. To increase a field's value, press the Unwrapped Cycle button. Hold the button down to increase the value.



5. To decrease the value, press and hold the Wrapped Cycle button.



6. To select the next field, press the Rubber and Plastics Cycle button.



7. To save changes and return to the regular operating mode, press the stop button.

7.4 Installing Paper into Statprinter



Use only paper approved for use with the Statprinter. The use of any other paper will damage the printer and will void the warranty. Thermal paper is available from SciCan (SciCan order no. 01-101657S).



Do not operate the printer without paper. If you run out of thermal paper, or if you do not wish to use the printer, turn it **OFF**.



Never pull the paper backwards through the printer. This will damage the printer mechanism.

To install the paper into the printer, follow these steps:

1. Power the Statim **ON**.
2. Open the printer door **1** by pushing on the top half of the door.
3. Power the printer **ON** **2**.
4. Unroll some paper from the thermal paper roll **3** and trim the corners using the paper cutting template included with each box.
5. Move the paper roll arm **4** into the loading position. Place the paper roll **3** on the arm so the paper strip feeds from the top of the roll and then carefully insert it into the paper feed slot **5** until it stops.

If the paper does not feed from the top, the heat sensitive side of the paper will not be in contact with the print head and the printer will not print.

6. With one hand, continue to gently feed the paper strip into the paper feed slot. With the other hand, press the paper advance button **6** until the paper feeds by itself.

Keep the paper straight when feeding it into the printer or it may jam. Do not force the paper into the slot! If the paper will not feed into the slot, pre-cut the end of the roll again and reload the paper.

7. The Optional Statprinter Cont'd.

7. Continue to press the paper advance button **6** until the paper feeds through the paper exit slot on the front of the printer. Then, move the paper roll **3** and arm into the operating position and close the printer door **1**. The printer is now ready to operate.

When you see a red line on one side of the paper, it is time to replace the roll.

If a paper jam occurs, and the paper cannot be removed by pressing the paper advance button **6**, do not pull the paper backwards through the printer.

Never put a utensil or tool into the paper exit slot. For full instructions on how to remove paper jams, see Section 7.5 Removing Paper Jams.

To replace the paper roll **3**, follow these steps:

1. With scissors, cut the paper between the roll and the paper feed slot **5**.
2. Remove the roll from the arm and discard the unused portion.
3. Press the paper advance button **6** to feed the paper that remains in the printer out of the slot at the front of the printer.
4. Install the new thermal paper roll by following the instructions described in this section.

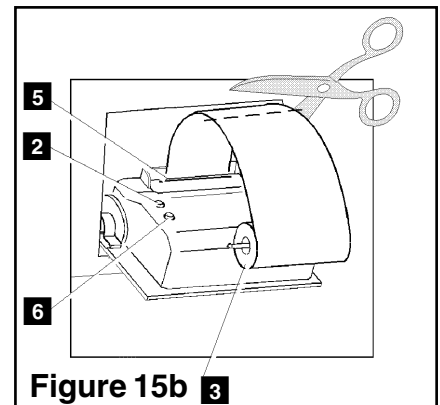
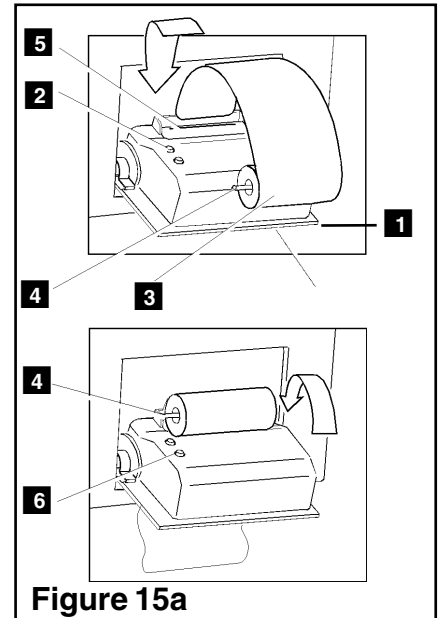

7.5 Removing Statprinter Jams

If paper jams in the printer and cannot be removed by pressing the paper advance button **6**, the printer must be disassembled. Do not pull the paper backwards through the printer and never put utensils or tools into the paper exit slot.

When paper is jammed in the printer, follow these steps to remove the jam:

1. Power the Statim **OFF** and unplug the unit.
2. Using scissors, cut the paper between the roll and the paper feed slot **5**.
3. Remove the paper roll **3** from the paper roll arm **4** and leave the arm in the loading position.
4. Using a #1 Phillips screwdriver, remove the three screws **7** from the printer cover **8** and remove the cover.

7. The Optional Statprinter Cont'd.

5. Note the orientation of the exposed printed wiring board **15** and the paper roll arm **4** assembled on the printer door **1**.
6. Gently lift the printed wiring board upwards and away from the printer door. Exercise care while handling the board. The printer is integral to the wiring board. Do not place strain on the connections of the ribbon cable soldered to the board. Do not remove the connector of the flexible cable from the connector header on the board. The paper drive mechanism on the underside of the wiring board is now exposed.
7. Using a pair of tweezers or fine needle-nosed pliers, carefully remove the paper from the mechanism.

When the paper is removed, reassemble the printer:

1. Carefully snap the paper roll arm **4**, in the loading position, back into the clips on the printer door **1**.
2. Place the printed wiring board **15** back into position on the printer door. Note the alignment of the mounting holes **9** in the wiring board and the mounting bosses **13** on the printer door. The black plastic printer body rests between the locating ribs **10** on the inside of the printer door.
3. Ensure that the flexible cables **11**, **14** are not pinched between the printer door and the wiring board.
4. Place the printer cover on the printer door. Ensure that the flexible cables are not pinched between the cover and the door. The power button and the paper advance button must protrude through the openings in the cover and operate freely.
5. Using a #1 Phillips screwdriver, secure the printer cover to the printer door with the three screws retained during the disassembly procedure. Do not over-tighten these screws.
6. Plug your Statim into the wall receptacle. For the Statim 2000, reconnect the printer if it was previously disconnected. Turn the power switch to the **ON** position.
7. Press the printer power button to the **ON** position. Load paper into the printer following the procedures in Installing Paper into the Statprinter.

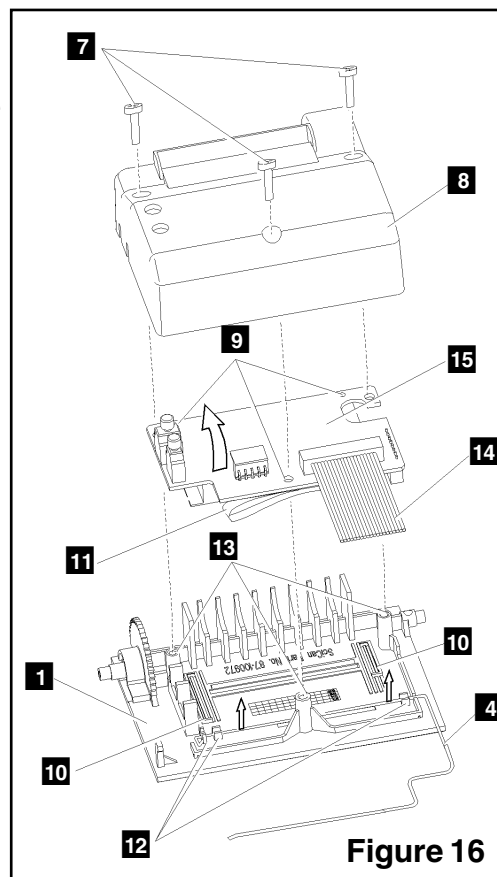

8. Warranty

Limited Warranty

For a period of one year, **SciCan** guarantees that the **Statim 2000 / 5000**, when manufactured by **SciCan** in new and unused condition, will not fail during normal service due to defects in material and workmanship that are not due to apparent abuse, misuse, or accident.

In the event of failure due to such defects during this period of time, the exclusive remedies shall be repair or replacement, at **SciCan's** option and without charge, of any defected part(s) (except gasket and filters), provided **SciCan** is notified in writing within thirty(30) days of the date of such a failure and further provided that the defective part(s) are returned to **SciCan** prepaid.

This warranty shall be considered to be validated, if the product is accompanied by the original purchase invoice from the authorized **SciCan** dealer, and such invoice identifies the item by serial number and clearly states the date of purchase. No other validation is acceptable. After one year, all **SciCan's** warranties and other duties with respect to the quality of the product shall be conclusively presumed to have been satisfied, all liability therefore shall terminate, and no action or breach of any such warranty or duty may thereafter be commenced against **SciCan**.

Any express warranty not provided hereon and any implied warranty or representation as to performance, and any remedy for breach of contract which, but for this provision, might arise by implication, operation of law, custom of trade or course of dealing, including any implied warranty of merchantability or of fitness for particular purpose with respect to all and any products manufactured by **SciCan** is excluded and disclaimed by **SciCan**. If you would like to learn more about **SciCan** products and features, visit our website at www.scican.com.

9. Specifications

9.1 Statim 2000 – Specifications

Machine Dimensions:	Length:	48.5 cm (19")
	Width:	41.5 cm (16.3")
	Height:	15 cm (5.9")
Cassette Size (External):	Length:	41 cm (16") includes handles
	Width:	19.5 cm (7.67")
	Height:	4 cm (1.6")
Cassette Size (Internal):	Length:	28 cm (11")
	Width:	18 cm (7.1")
	Height:	4 cm (1.6")
Sterilization Chamber Volume:		1.8 L (61 fl. oz.) U.S.
Reservoir Volume:		4.0 L (140 fl. oz.) U.S.
Weight (Without water):		21 kg (46 lbs)
Clearance required:	Top:	50 mm
	Sides:	50 mm
	Back:	50 mm
	Front:	48 cm
Maximum Steam Temperature:		138 °C (280 °F)
Maximum Operating Pressure:		341 kPa abs (49.5 psia)
Electrical Rating* (+ / - 10 %):		100 V, 50 / 60 Hz, 11 A 110 V, 60 Hz, 11 A 220-240 V, 50 / 60 Hz, 6 A
*see serial number label for requirements specific to your unit.		
Protection Class:		I
Protection:		covered (indoor use only)
Ambient Operating Temperatures and Humidity:		15 °C to 25 °C (59 °F to 77 °F) and 25 % to 70 %
Altitude:		Up to 2000 meters (6600 ft)
Installation Category:		1
Statprinter Specifications:	Type:	Thermal Printer
	Print:	20 characters per line
	Print Speed:	1 line per second
	Paper Roll Capacity:	approx. 80 sterilization cycles per roll

9. Specifications Cont'd.

9.2 Statim 5000 – Specifications

Machine Dimensions:	Length:	55 cm (22")
	Width:	41 cm (16")
	Height:	19 cm (7.5")
Cassette Size (External):	Length:	49.5 cm (19.5") includes handles
	Width:	19.5 cm (7.67")
	Height:	8.0 cm (3.2")
Extended Cassette Size (External):	Length:	56.5 cm (22.2")
	Width:	19.5 cm (7.67")
	Height:	8.0 cm (3.2")
Cassette Size (Internal):	Length:	38 cm (15")
	Width:	18 cm (7.1")
	Height:	8.0 cm (3.2")
Extended Section (L x W x H):	11 cm (4.3") x 13 cm (5.1") x 1.6 cm (0.63")	
Sterilization Chamber Volume:	5.1 L (170 fl. oz.) U.S.	
Reservoir Volume:	4.0 L (140 fl. oz.) U.S.	
Weight (Without water):	33 kg (73 lbs)	
Clearance required:	Top:	50 mm
	Sides:	50 mm
	Back:	50 mm
	Front:	57 mm
Maximum Steam Temperature:	138 °C (280 °F)	
Maximum Operating Pressure:	341 kPa abs (49.5 psia)	
Electrical Rating* (+ / - 10 %):	100 V, 50 / 60 Hz, 11 A 110 V, 60 Hz, 11 A 220-240 V, 50 / 60 Hz, 6 A	
*see serial number label for requirements specific to your unit.		
Protection Class:	I	
Protection:	covered (indoor use only)	
Ambient Operating Temperatures and Humidity:	15 °C to 25 °C (59 °F to 77 °F) and 25 % to 70 %	
Altitude:	Up to 2000 meters (6600 ft)	
Installation Category:	1	
Statprinter Specifications:	Type:	Thermal Printer
	Print:	20 characters per line
	Print Speed:	1 line per second
	Paper Roll	
	Capacity:	approx. 80 sterilization cycles per roll