

Pelton & Crane

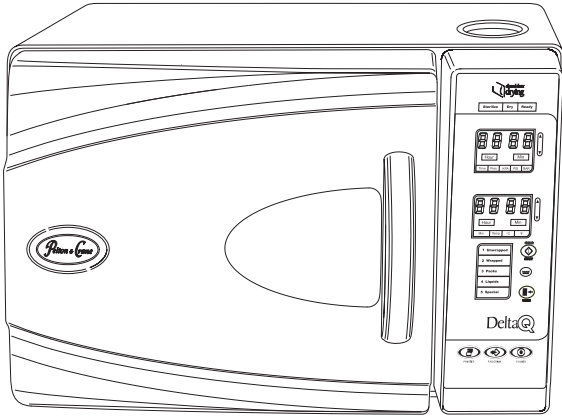

Model AE (8")

Delta Q

Use & Care Manual

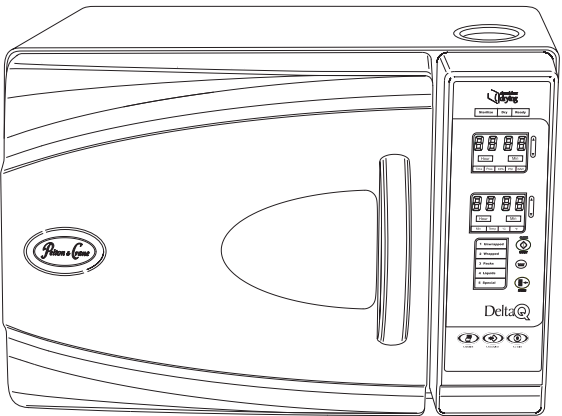

Model AF (10")

TABLE OF CONTENTS

Dear Customer

Congratulations on the purchase of your new Delta-Q Sterilizer. The technical documentation provided is designed as a part of this product. Always keep this documentation handy. The Use & Care Manual describes the 8” and 10” models. Please read the instructions and get to know the autoclave. Please carryout maintenance according to relevent instructions.

DELTA Q CONTENTS

TABLE OF CONTENTS.....	2
SAFETY INSTRUCTIONS.....	3
GENERAL INFORMATION.....	4
PRODUCT INFORMATION.....	5
FAMILIARIZATION.....	6
FAMILIARIZATION.....	7
FAMILIARIZATION.....	8
INSTALLATION.....	9
PROGRAMMING.....	10
OPERATION.....	11
OPERATION.....	12
OPERATION.....	13
MAINTENANCE.....	14
MAINTENANCE.....	15
MAINTENANCE.....	16
MAINTENANCE.....	17
MAINTENANCE.....	18
MAINTENANCE.....	19
MAINTENANCE.....	20
OPTIONS.....	21
INSTALLATION AND SERVICING CHECKLIST.....	22
NOTES.....	23

Technical Support

Technical assistance is available Monday through Friday,
8:00 am to 6:00 pm (Eastern Standard Time).

<p>Phone: 800-659-5922 Fax: 704-583-8506 Customer Service: 800-659-6560</p>

SAFETY INSTRUCTIONS

! IMPORTANT SAFETY INSTRUCTIONS !

Caution! Personal Safety

- To avoid electrical shock, never insert plug into outlet with wet hands.
- Do not attempt to open door unless pressure gauge reads "0" or injury may result.
- Do not operate Sterilizer in area containing combustible gases.
- Do not place Sterilizer within 6 feet of patient.
- Routinely inspect power cord for cuts and abrasions. Discontinue use and have authorized service representative replace cord if damaged.
- Protect your hands from contact with soiled instruments to prevent serious infections. Wear heavy rubber gloves when handling instruments.



Caution! Check weekly for proper door switch operation (see pg. 14).



WARNING: To Avoid Serious Burns:
Do not open door during sterilization cycle. Stand to one side when opening door after sterilization cycle and do not place hands or face over door.

- Use a tool or hot pad to remove trays and avoid touching chamber walls.
- Stand away from door after the sterilization cycle is completed. Liquids may still be in the chamber and can cause serious burns.
- Ensure unit is properly leveled. Follow the Installation Instructions on page 9.
- When performing safety valve maintenance (pg. 14) stand clear of discharge area (lower left corner at rear of unit) facing unit.



Do not remove cover: Electrical shock hazard. Refer servicing to authorized service representative. Disconnect power before servicing.



DANGER: Do Not attempt to open door with pressure in the chamber. Avoid direct contact with hot chamber walls or sterilized load.



WARNING: To avoid serious burns — If used for liquid sterilization, the liquid must be allowed to cool or the liquid may boil when exposed to atmospheric pressure. Pelton & Crane does not recommend use of this device for liquid sterilization.



WARNING: Do not use excessive force to open door

- Product Safety**
- This unit requires a dedicated circuit (separate branch circuit only).
 - Always use distilled quality water. Tap water will cause corrosion of chamber and clog valves and filters with mineral deposits.
 - Never operate unit outside the specified voltage range (see data plate on back of unit).
 - Do not use steel wool or steel brushes on stainless steel. Metal pads will damage chamber.
 - Use only manufacturer's replacement parts/accessories. Failure to do so may cause poor performance.
 - Refer servicing to authorized service representative.
 - Do not position the unit so that it is difficult to reach the circuit breaker on the power plug.

- Interference with electromedical devices:**
- To guarantee the operational safety of electromedical devices, it is recommended that the operation of mobile radio telephones in the medical practice or hospital be prohibited.
 - Strong EMI sources such as electro surgery units or x-ray units may effect performance. If performance problems occur, move the sterilizer to another electrical circuit or physical location.



WARNING: After completion of sterilization cycle, all contents of the sterilizer chamber and the chamber itself may be very hot. Avoid direct contact with hot chamber and sterilizer load.



CAUTION: Any liquids that are sterilized in this unit are for laboratory use only and not for use in direct patient contact.

GENERAL INFORMATION

A steam sterilizer (autoclave) is a device that is intended for use by a health care provider to sterilize medical products by means of pressurized steam.

The dental delivery system is classified as Class II device under rule FDA CFR 21, Class II device under Health Canada guidelines.

Definition of Symbols

The following symbols may be used throughout this manual:

 **CAUTION:** Failure to carefully follow the described procedure may result in damage to the equipment.

 **WARNING:** Failure to carefully follow the described procedure may result in damage to the equipment and operator.

 Risk of electrical shock present. Make sure power is disconnected before attempting this procedure.

The following symbols may be located throughout the product:



Power



Ground



Mode



Printer Connection



Printer On/Off



Arrows



Attention: Printer Connection Only



Clear/Start

 **CAUTION:** This product is intended for use by trained dental/medical professionals only.

Product Disposal

Contact your local authorized dealer for proper disposal of the device to ensure compliance with your local environmental regulations.

Interference with Electromedical Devices

To guarantee the operational safety of electromedical devices, it is recommended that the operation of mobile radio telephones in the medical practice or hospital be prohibited.

Strong EMI sources such as electro surgery units or x-ray units may effect performance. If performance problems occur, move the sterilizer to another electrical circuit or physical location.

 **WARNING:** This product must be disinfected before use.

To disinfect:

- Pour half gallon distilled water into reservoir. Run one "Unwrapped" cycle

Note: It is not necessary to complete drying cycle.

- Wipe the inside of the chamber, the boiler ring and the door gasket. Fill reservoir with distilled water. Sterilizer is ready for use.



Program



Hot Surface



Low Water



Dry



Ready



Sterilize



Electrical Testing Lab

PRODUCT INFORMATION

Specifications

8" Model

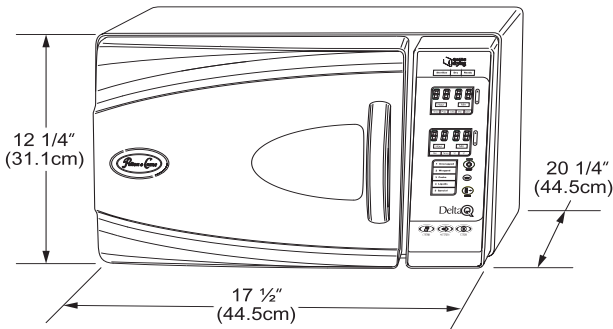

Exterior Dimensions

8" Model-

12 1/4" high x 20 1/4" deep x 17 1/2" wide
(31.1 cm high x 51.4 cm deep x 44.5 cm wide)

10" Model-

14" high x 24 5/8" deep x 19 1/4" wide
(35.6 cm high x 62.5 cm deep x 48.9 cm wide)

Chamber Dimensions

8" Model-

8 7/32" inside diameter x 14" useable depth
(21 cm inside diameter x 35.6 cm deep)

10" Model-

9 7/8" inside diameter x 17 7/16" useable depth
(25.1 cm inside diameter x 44.3 cm deep)

Weight Without Water in Reservoir

8" Model-

61 lbs. (28 kg)

10" Model-

84 lbs. (38 kg)

Measurement Accuracy

Pressure: +/- 8 kPa (1.16 PSI or .08 bars)

Temperature: +/- 3.6° F (2° C)

Time: +/- 1 second

Power Supply

Both Models-

110 - 120 Volts, 50/60 Hz or

220 - 240 Volts, 50/60 Hz

Nominal Current Consumption

8" Model-

12 Amperes @115 Volts

6 Amperes @230 Volts

10" Model-

10 Amperes @115 Volts

8 Amperes @230 Volts

Environmental and Storage Limitations

MODEL AE, MODEL AF:

Optimum Operating Temperature Range:

50°F to 104°F

(10°C to 40°C)

Relative Humidity Range:

30% to 75%

Unit is designed for normal dental/medical office environment.

PRINTER: If printer is used, its operating temperature is 41°F to 95°F (5°C to 35°C).

Mode of Operation:

Both Models- Continuous

NOTICE: Manufacturer will make available all information which will assist the authorized service representative to repair equipment. Calibration of the power board is to be done only at the factory.

10" Model

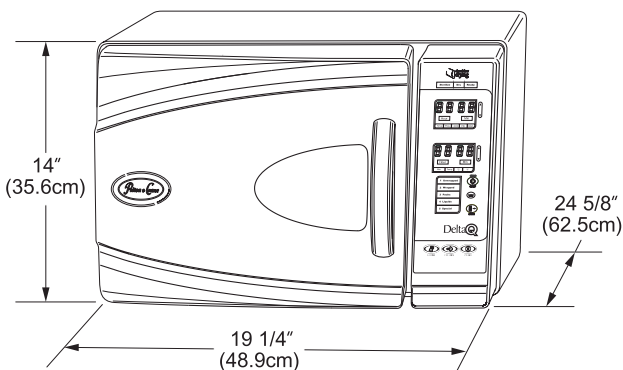

FAMILIARIZATION

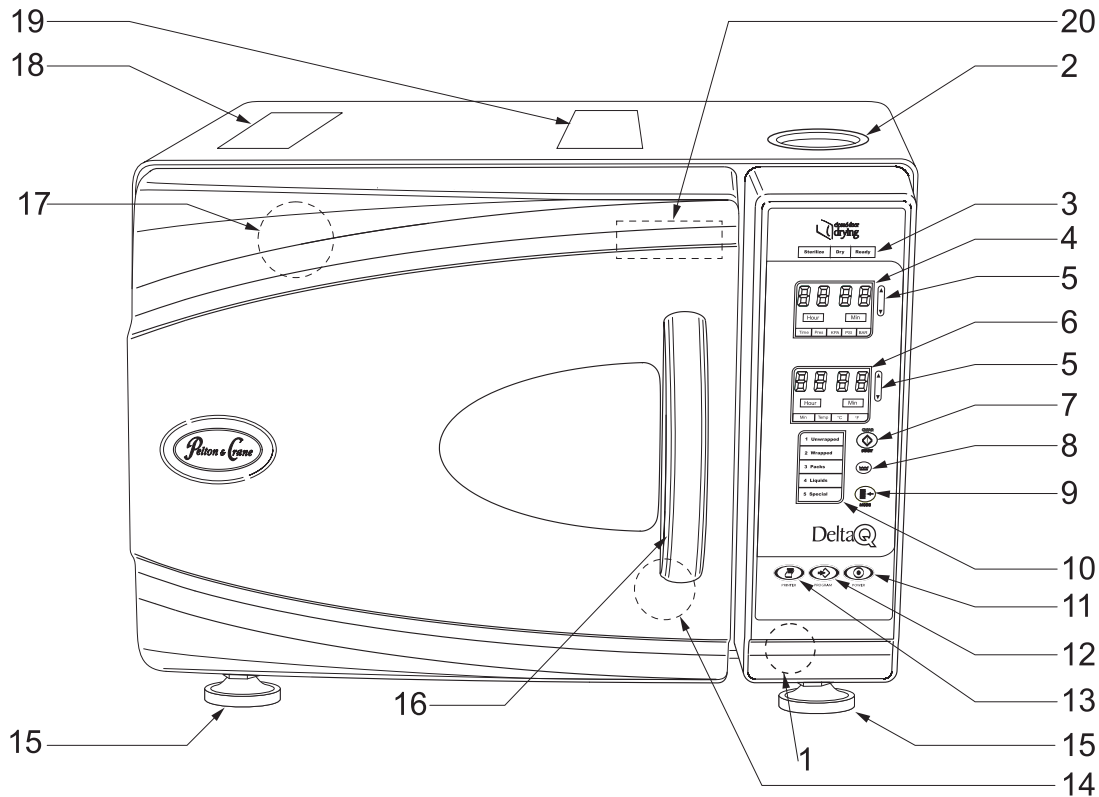

OPERATING FEATURES

1. Power Switch/Circuit Breaker (rear of unit)
2. Reservoir Fill
3. Operation Indicator Light
4. Display Window (Pressure) kPa
5. Arrow Switches
6. Display Window (Temp/Time) C/F / Minutes
7. Clear/Start Switch
8. Low Water Light
9. Mode Selection Switch
10. Mode/Program Display
11. Power On Switch
12. Programming Switch
13. Printer On/Off Switch
14. Quick Drain Connection (inside door)
15. Leveling Feet
16. Door Latch
17. Safety Valve (rear corner of unit)
18. Operating Instructions Label
19. Caution Label
20. Serial Number Plate (inside door)

SAFETY FEATURES

The design of the sterilizer has these safety features for your protection:

Door Lock

Door can be opened only when internal pressure is at atmospheric pressure.

Vent Valve

The vent valve will open and the P-2 alarm will display should the chamber pressure exceed 240 kPa.

Safety Valve

The safety valve opens as backup protection should the chamber pressure exceed 262 kPa.

Overheat Protection

Chamber temperature is protected with a surface sensor so the surface temperature will not exceed 159°C. It has additional overheat protection should the temperature of the heating elements reach 180°C.

Electrical Power Interruption

In case of a power failure during the sterilization cycle, pressure in the chamber is automatically vented to the atmosphere and display is blank

FAMILIARIZATION

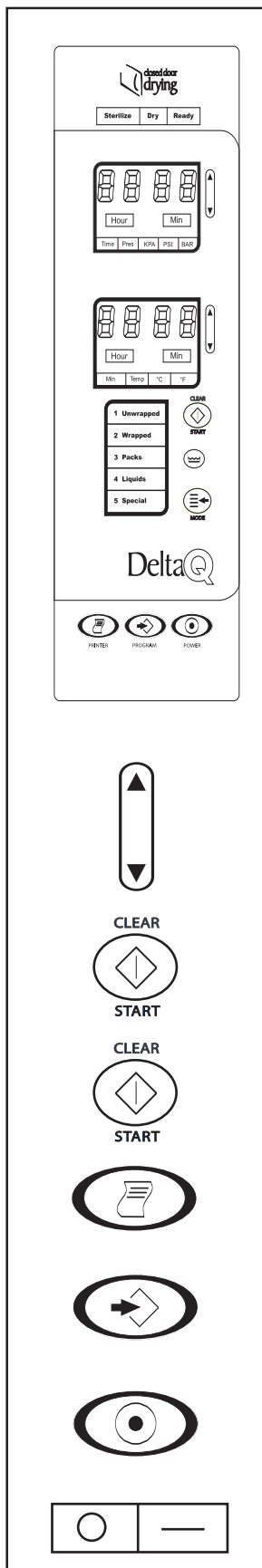

VISUAL DISPLAYS

Indicator Lights

“Sterilize” light illuminates to indicate sterilization cycle in progress.
 “Dry” light indicates the heater and pump are on for the drying cycle.
 “Ready” light illuminates when instruments may be removed from chamber.

Upper Window

Displays Time, Pressure, Clock and Year.

Lower Window

Displays Temperature, Date, Operational Timer, Failure Codes, Power colon “.” (power button is not activated when main power is ON) and End.

Mode/Program

See Program Parameters, pg. 10.

Low Water

When the water level in the reservoir is too low, the “Low Water” light illuminates.

SWITCH FUNCTIONS- ONLY WORKS IN STANDBY

Arrows

Increases or decreases values of digits flashing when programming the system parameter.

Clear/Start

Controls the start of a sterilizing cycle when unit is in stand-by. Also, used to clear a cycle and returns unit to stand-by. If depressed with “Power” switch, self-diagnostic check is performed.

Mode Selection

Press to select one of the five sterilization mode programs. (See page 10 for special mode)

Printer On/Off

Use to switch the printer on or off.

Program

Sets the minutes, hour, day, month and year. Chooses units of temperature and pressure. Changes the drying time. Also, chooses the Special mode to the parameter desired. It initiates selected display mode during sterilization.

Power

Powers on operating controls. LCD will be visible. If depressed with “Clear/Start” switch, self-diagnostic check is performed.

Main Power (back of unit)

Depress “I” side of switch to turn unit on. A colon “.” illuminates in the lower display indicating power is on. Leave switch in the On position.

FAMILIARIZATION

AUDIBLE SIGNALS

Switches

One beep occurs when pressing switches, except when pressing Power Switch and Arrow switches. When pressing Arrow or Power Switch, no beep occurs.

Sterilization/Dry Cycle



Five beeps indicate the Sterilization or Drying cycles are complete.

Operational Alarm

Sixty beeps indicates an operational error or alarm. Press Clear/Start to put unit in standby mode.

Door Open

Continuous beeping indicates the door has been opened during or prior to start of cycle.

PROGRAM PARAMETERS*	
Program/Temp**, Pres, Time**	Items to be Sterilized
1 Unwrapped/ 134°C, 216 kPa for 3 minutes	Instruments loose on a tray. Open glass or metal canisters. Heat-resistant rubber tubing which will not be used in surgical procedure. Any items where 134°C-137°C for 3 minutes is appropriate.
2 Wrapped/ 134°C, 216 kPa for 12 minutes	Wrapped dental handpieces***. Multiple layers of instruments separated by fabric. Instruments in pouches. Wrapped tray of loose instruments. Heat-resistant rubber tubing. Any items where 134°C-137°C for 12 minutes is appropriate.
3 Packs/ 121°C, 115 kPa for 30 minutes	Common groups of surgical instruments in commercially prepared packs. Surgical instruments subject to prolonged storage. Any items, other than liquids, where 121°C for 30 minutes is appropriate.
4 Liquids/ 121°C, 115 kPa for 30 minutes	Liquids or gels that could boil or spill out of container. At end of sterilizing cycle, venting is slowed to allow heat in liquid to dissipate slowly and eliminate boilovers. Venting occurs at 20 kPa to complete the cycle. There is NO drying cycle in the "Liquids" mode.
	 CAUTION: ANY LIQUIDS THAT ARE STERILIZED IN THIS UNIT ARE FOR LABORATORY USE ONLY AND NOT FOR USE IN DIRECT PATIENT CONTACT.
	 WARNING —To avoid serious burns — If used for liquid sterilization, the liquid must be allowed to cool or the liquid may boil when exposed to atmospheric pressure. Pelton & Crane does not recommend use of this device for liquid sterilization.
5 Special/ Programmable to 101°C to 135°C, for 1 to 90 minutes.	 CAUTION: Dependent upon parameters user has programmed. Operator is responsible for correct time and temperature settings for load.

* For mixed loads, use the longer or lower temperature program (i.e., for loose instruments and surgical dressings in packs, use Packs).

** Time and temperatures are minimums.

*** When sterilizing handpieces, check handpiece manufacturer's recommendations for appropriate sterilization conditions. Use Wrapped program only if handpieces are able to withstand 134°C-137°C temperature.

The names of the various modes of operation are general categories.

When selecting the mode of operation, take into consideration the density of the individual load and the ability of the steam to circulate and penetrate wraps. Then determine the correct programmed values to assure sterilization.

INSTALLATION

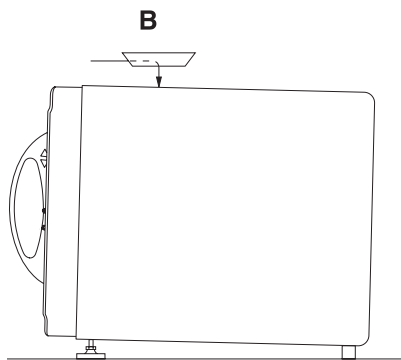

1. Remove all packing material from chamber.
2. Place unit on a level countertop.
3. Peel protective cover from tape on top of casing and place operating instruction card (B) (with the appropriate language for the operator, facing up) on the tape and press down firmly.

NOTE: If unit has been stored in cold conditions, allow it two hours to warm up to room temperature before operating.

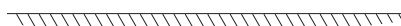

4. Plug power cord into a receptacle that is on a dedicated circuit. Ensure that the circuit has the proper fuse or breaker to accommodate the maximum power of the unit. Properly install per your local electrical codes. (See illustration C).

Power Cord Configurations and Ratings.

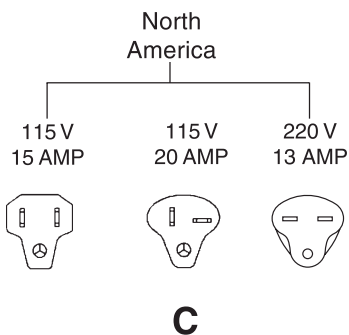

5. This unit has been pre-leveled during manufacturing therefore “NO” leveling is required. However, if the unit is placed on a surface that is not level then follow the leveling instructions below:

- Remove all trays from the chamber.
- Pour distilled water into chamber.
- Adjust leveling feet (D) until water comes to the pull tab of the inline filter assembly (F) (located in the rear of chamber) and reaches the top of water dam (G) at the front of chamber.
- Reinstall trays and tray rest.
- Close door and run one cycle on the unwrapped cycle according to the operating instructions.

IMPORTANT: Carefully read the Programming Set-up instructions and program unit accordingly. (Refer to page 10).

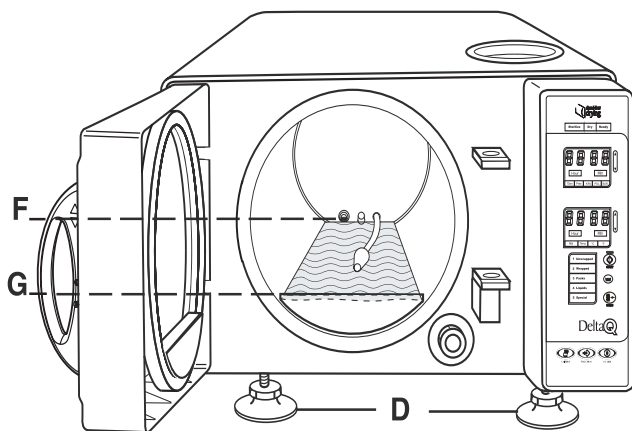

NOTE: The unit has a special automatic preheat mode that warms chamber for quicker cycle times, between 0600 and 1800 hours.

NOTE: If unit is not to be used for extended period of time. Turn OFF main power switch located in the back of unit.

WARNING: Counter top must be wide enough to support all unit feet. All unit feet must be securely placed on counter top.

PROGRAMMING

	Operator Action	System Response
	<p>1. Press “Program” button. Use Arrows to increase or decrease Time and Month to correct settings.</p> <p>Note: Properly program the time, since preheat starts 0600 hours and stops at 1800 hours.</p>	<p>Hours (based on military time) and month (ranges 1 - 12) display flashes.</p>
	<p>2. Press “Program” button a second time. Use Arrows to increase or decrease Minute and Day to correct settings.</p>	<p>Minute (ranges 00 - 59) and Day (ranges 1 - 31) display flashes.</p>
	<p>3. Press “Program” button a third time. Use Arrows to correctly set Year and choose to display the Minutes remaining in the sterilization cycle or the Temperature during cycle.</p>	<p>Year (ranges 00 - 99) and Minute or Year and Temperature display flashes.</p>
	<p>4. Press “Program” button a fourth time. Use Arrows to select preferred Pressure and Temperature unit of measure for display.</p>	<p>Unit of Measure Indicator for Pressure (kPa, PSI or Bars) and Unit of Measure Indicator for Temperature (C or F) display flashes.</p>
	<p>5. Press “Program” button a fifth time. Use Arrows to increase or decrease Time and Temperature settings for programming “Special” mode.</p>	<p>“Special” Program mode flashes. Current settings for Time and Temperature of Special Program are displayed.</p>
	<p>6. Press “Program” button a sixth time. Use Arrows to increase or decrease Time for Drying cycle.</p>	<p>“Dry” indicator light flashes. Minutes (ranges 0-99) display flashes. (30 Minutes is the recommended minimum time which is preset at the factory.)</p>

OPERATION

Important Sterilization Practices



CAUTION: Do Not overload chamber. Refer to “Preparation and Loading”.



CAUTION: Do not exceed maximum loading configuration. Otherwise, inadequate sterilization could result.



CAUTION: Become familiar with the individual functions of the five (5) modes to ensure using proper sterilization cycle. Wrong mode selection or improper loading may result in improper sterilization.

- All functions of the sterilizer should be monitored to provide maximum sterility assurance. We recommend using Pelton & Crane’s printer to provide a permanent record of actual exposure times and temperatures.
- For additional assurance that minimum sterilizing conditions have been achieved, good sterilization practices recommend the use of a quality temperature sensitive process indicator with each cycle and within each package.
- Since temperature sensitive process indicators do not integrate sterilization parameters, biological monitoring is recommended to provide further information in detecting inadequate sterilizer performance. Biological indicators can be used to integrate the various cycle parameters and indicate whether sterilization conditions have been met in a particular cycle.
- Thoroughly clean instruments before placing them in the sterilizer. Processing instruments with debris or blood contamination impedes sterilization and may result in staining and/or damage to instruments or sterilizer. Use no cleaners with chlorine.
- Follow manufacturer’s recommendations for the individual items before sterilizing.
- Use proper sterilization and instrument handling as recommended by ADA, CDC, AAMI, AORN and OSAP guidelines.
- Do Not use staples, pins or other devices which will puncture the packaging material as sterility may be compromised.
- Do Not sterilize instruments while running cleaning cycle.
- Sort instruments by type of metals. Do Not mix carbon steel stainless steel, brass, aluminum, chrome or other types of metals as plating may occur.
- Place loose instruments on towel or absorbent paper.
- Wrapped packages **Must Not** touch sides.
- Place pouches with paper side down.
- Place open containers tilting downward in tray.
- Do Not attempt to sterilize long tubing as steam may not penetrate the full length.
- Do Not wrap instruments too tightly. Inadequate sterilization may result from improper wrapping or placing too many instruments per package.

Sterilization Assurance

Clinical Record Keeping

- Review daily and weekly records to substantiate procedures taken to assure sterilization.

Techniques for Sterilization Assurance

- Use internal sterilization process indicators inside all sterilizer loads to verify gross heat penetration.
- Once per week, use a biological spore test indicator (BI) designed for gravity steam sterilizer operating at 121°C (Attest®, Biological Monitoring System, 3M, St. Paul, MN; or equivalent) or 134°C (EZ Test, Bozeman, MT) to test each type of cycle used at your facility.
 - Load sterilizer to maximum load used at your facility.
 - For “Wraps” and “Packs” Cycle, place biological indicator inside wrap or pack containing instruments and then place this pack or wrap in front lower tray of the sterilizer. (This is the cold spot, i.e. lowest temperature condition.)
 - For Unwrapped Cycle, load trays with instruments, place biological indicator in front lower tray of sterilizer.



CAUTION: ANY LIQUIDS THAT ARE STERILIZED IN THIS UNIT ARE FOR LABORATORY USE ONLY AND NOT FOR USE IN DIRECT PATIENT CONTACT.

- Follow manufacturer’s instructions for using all test materials and maintaining good clinical records.
- Follow Maintenance schedule on page 14 to ensure proper operation of the autoclave.
 - Note: Indicator tape should not be used as a sterilization indicator. It has a temperature sensitive stripe that changes color with temperature only.

OPERATION

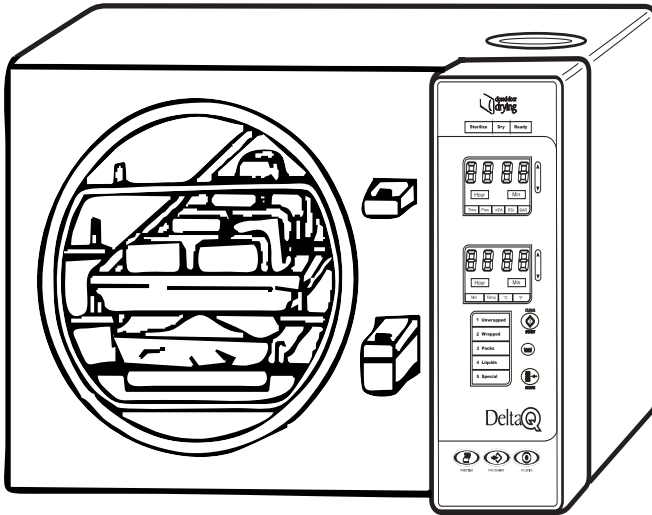

Preparation and Loading

- Clean and dry items thoroughly.
- Properly seal items in wrap or pouch if load is to be kept sterile during storage. Recommended wrap/pouch materials are cloth, paper, or paper/poly pouches. Nylon pouches/tubing are not recommended.
- This unit is not suitable for sterilization of gowns/fabrics, "porous load".
- Place temperature sensitive process indicator inside package.
- Place temperature sensitive indicator in front portion of bottom tray.
- Place load on tray with space between instruments or packages so that steam can flow between items.
- Place trays in chamber with adequate space for steam circulation.

The Following are recommended maximum loading configurations:

Wrapped/Unwrapped Cycle

- **Model AE:** Total weight not to exceed 1.5 lbs. This is equivalent to approximately 9 handpieces or hinged instruments (average weight of 2.3 ounces) or 30 hand instruments (average weight of 1 ounce.)
- **Model AF:** Total weight not to exceed 2 lbs. This is equivalent to approximately 13 handpieces or hinged instruments (average weight of 2.3 ounces) or 42 hand instruments (average weight of 1 ounce.)

Packs Cycle

NOTE: When calculating maximum load, use the same weight and instrument equivalencies as specified in the "Wrapped/Unwrapped" cycle.

- **Model AE:** Total weight not to exceed 1.5 lbs. One (1) pack in top tray and one (1) in bottom tray with pack dimensions not to exceed 5" x 7" x 1/4".
- **Model AF:** Total weight not to exceed 2 lbs.. Two (2) packs in top tray and one (1) in bottom tray with pack dimensions not to exceed 5" x 7" x 1 1/2".



CAUTION: ANY LIQUIDS THAT ARE STERILIZED IN THIS UNIT ARE FOR LABORATORY USE ONLY AND NOT FOR USE IN DIRECT PATIENT CONTACT.

Dental Handpieces: Check handpiece manufacturer's recommendations for appropriate sterilization conditions. Use Wrapped program only if handpieces are able to withstand 134°C - 137°C temperatures.

OPERATION

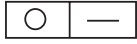
 (power switch for main power supply is located on the backside of unit)

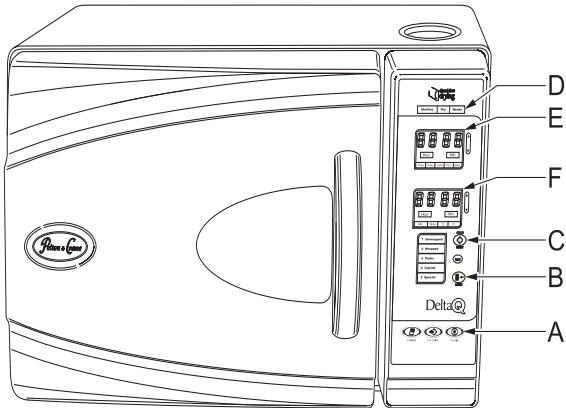

Operating Steps

NOTE: Add distilled water to bottom of filler cup opening. Ensure water is covering condenser coil for proper operation.

Add distilled water to reservoir between cycles if “Low Water”  light is on. Close and latch door.

- At start of day, depress “Power” switch (A) to provide power to operating system.
- Ensure proper mode (B) is selected for load to be sterilized.
- Depress “Clear/Start” (C) switch. Unit will automatically fill; build up steam pressure while expelling air; sterilize for selected time; vent and dry for the programmed drying time.
- Open door and unload after drying cycle is complete: “Ready” light (D) is on; five beeps occur; zero (0) pressure indicated in upper display window (E) and “End” is displayed in lower display window (F) if door is not opened prior to completion of drying cycle.
- **Note:** Do not run sterilization cycle with drying until the unit has preheated for 30 minutes. Otherwise, inadequate drying may occur.
- **Note:** Sterilized items may be removed any time during the drying cycle. Use caution as items may be hot and wet. Wet items will not remain sterile for any length of time.
- **Important:** Examine each pouch before and after the sterilization cycle for open seals or tears. If there is a breach of pouch integrity, reseal in a new pouch and resterilize.



CAUTION: Special temperatures set below 121°C should not be used for sterilization, but for disinfection only.



WARNING: Do Not attempt to open door with pressure in the chamber. Avoid direct contact with hot chamber walls or sterilized load. Use metal handle and gloves.

MAINTENANCE



CAUTION: The unit is in preheat mode between 0600 - 1800 hours. So that unit will be cool to the touch, turn off unit at main power switch (back of unit) 30 minutes before performing maintenance.

Maintenance and Performance Check Schedule			
CHECK	FREQUENCY	PROCEDURE	ACTION
Clean chamber	After every 25 cycles	4 ozs. Omni-Cleaner Plus® per 64 ozs. distilled water.	See "Cleaning Procedures" on pg. 15.
Door gasket	Weekly	Inspect and clean using Omni-Cleaner Plus® or mild detergent and water. Check for leaks and have leaking gasket replaced. WARNING: Leaking gasket could result in harm to the operator because of escaping steam.	Call authorized service representative for replacement gaskets. NOTE: For proper operation use only our replacement parts available through authorized service dealers.
Door latch	Weekly	Inspect latch mechanism for signs of wear or improper closure.	Call authorized service representative if improper closure or signs of wear are noted.
Bio Indicator	Weekly	Conduct testing using biological spore test indicator as described in "Operation, Sterilization Assurance."	If test fails, do not use other items in with that load. Ensure that "Important Sterilization Practices" and "Preparation and Loading" sections in this manual have been followed. Retest using an empty chamber, then retest with properly packaged and loaded chamber. If test still fails, discontinue using sterilizer and contact an authorized service representative.
Door switch	Weekly	With door open, attempt to start cycle. If door alarm does not appear on alarm display, door switch is defective or requires adjustment. Unit should not operate.	Call authorized service representative.
Boiler ring	Weekly	Inspect for deposits.	Clean using non-chlorinated pad which contains no metals.
Operation check	Weekly	Perform test described on page 11.	Call authorized service representative if failure occurs.
Water filters	Monthly	Remove filter in chamber. Put filter in ultrasonic cleaner. Scrub with small soft brush under running water and replace filter. When replacing, make sure filter in chamber touches center bottom wall of chamber to ensure proper draining.	If filters are clogged or cannot be cleaned, call an authorized service representative for replacement filters.
Air filter	Every Service Call Annually	Inspect air filter for cracks and loose tubing connections. Replace Filter	Have service representative remove the cover and inspect. Call authorized service representative.
Safety valve ring	Every 3 months	Manually pull ring (located on upper rear of chamber) when chamber pressure reaches 121 kPa. When pressure is relieved, valve automatically retracts. WARNING: When ring is pulled on safety valve with unit under pressure, steam is discharged from the chamber straight down the pipe at high temperature. When you pull ring, steam exits out bottom. Make sure path is clear and that your hand is out of the way.	If valve does not open or does not completely seal off after operation, turn off "Power" and call authorized service representative for replacement.

It is recommended that you annually have your sterilization system inspected by an authorized service and retain maintained records for the following:

1. Hi-Pot Test
2. Terminal Inspection
3. Internal Tubing inspection for leaks.
4. Filter replacements.
5. Ground continuity test.
6. Internal wire inspection for frayed wire.

Note: For detailed service instructions, refer to sterilizer Service Manual.



CAUTION: Unauthorized maintenance can damage sterilizer and will void manufacturer's warranty

MAINTENANCE

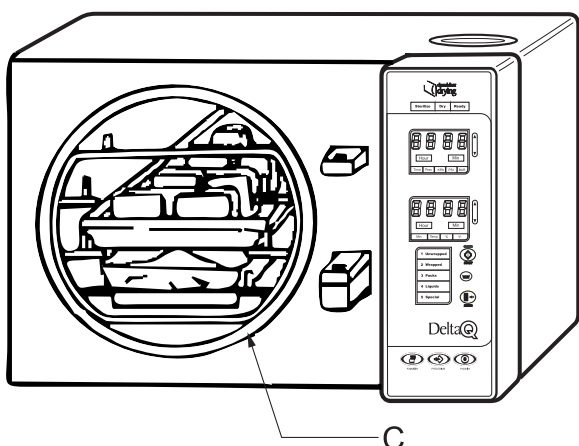
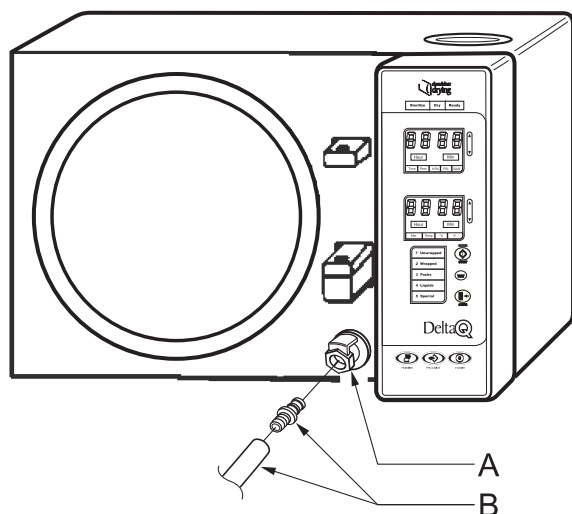

Cleaning Procedures

NOTE: Proper cleaning at regular intervals is essential, since mineral deposits, debris or trash may cause the unit to malfunction.

Draining Reservoir

With the door open, locate the quick drain connection (A) at the lower right corner of the face plate. Press the drain tube connector (B) provided with the unit into the connection on the face plate. This opens the drain line and draining of the reservoir will begin immediately.

Normal Chamber Cleaning

Drain the reservoir using quick connect drain tube. Mix Omni-Cleaner Plus® with distilled water according to directions on bottle. Pour into reservoir. Run one "Unwrapped" cycle

Note: It is not necessary to complete drying cycle.

Drain reservoir. With the drain tube in place, pour one to two gallons of water into the reservoir until the drained water is clear.

This will remove excess suds. Wipe inside of the chamber with soft cloth.



WARNING: Do Not sterilize instruments while cleaning autoclave.

Pour half gallon distilled water into reservoir. Run one "Unwrapped" cycle

Note: It is not necessary to complete drying cycle.

Wipe the inside of the chamber, the boiler ring (C) and the door gasket. Fill reservoir with distilled water. Autoclave is ready for use.

Cleaning Deposits and Discoloration on Stainless Steel

For deposits not removed by detergent solution, use a non-chlorinated, non-metallic scouring pad such as Scotch-Brite® or a powder such as Bon-Ami®.



CAUTION: Do not use ordinary steel wool or steel brushes on stainless steel. Pads containing metal will damage chamber and cause instruments to be stained with rust.



CAUTION: Do not use chlorinated cleaners. Doing so will cause corrosion. Rub in direction of pattern or grain of the metal. Clean stainless steel surfaces contaminated with discoloration with a 5% solution of warm oxalic acid.

MAINTENANCE

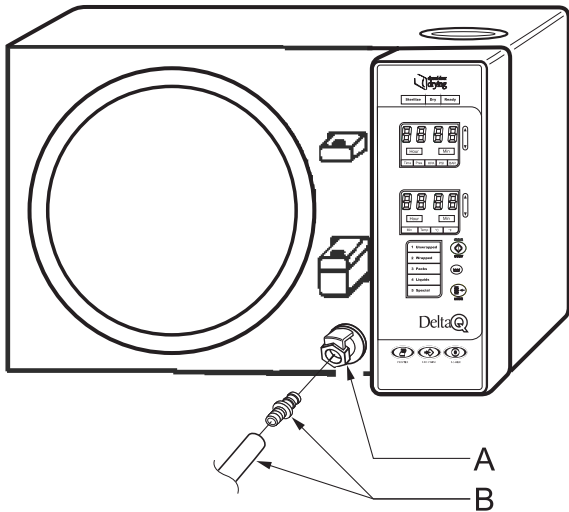

Cleaning Procedures (cont'd)

Cleaning Boiler Ring (C)

Clean boiler ring using a non-chlorinated, non-metallic scouring pad such as Scotch-Brite®.

Cleaning Door Gasket (D)

Clean door gasket with Omni-Cleaner Plus® or non-chlorinated detergent and water. Note: If residue is allowed to accumulate, the seal could be affected and leaks may occur.

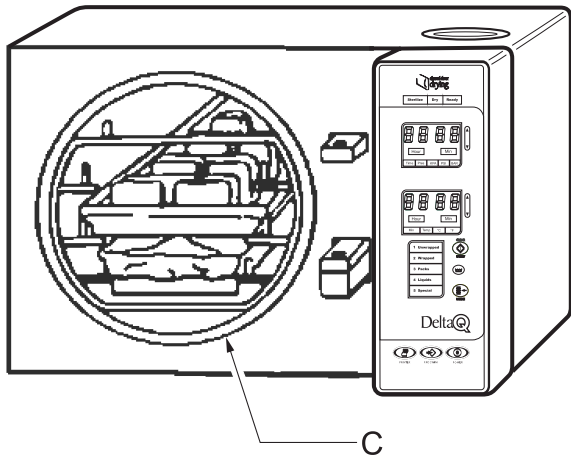

Cleaning/Disinfecting Exterior Surfaces

Clean all exterior surfaces with mild detergent and water using a sponge or cloth. Disinfect exterior surfaces using an iodophor (Biocide, Biotrol, Inc., or equivalent).



CAUTION: Do Not use any disinfectant on interior stainless steel surface. Damage to the chamber and/or trays may result.



CAUTION: Do not use instruments if unit fails to complete cycle.

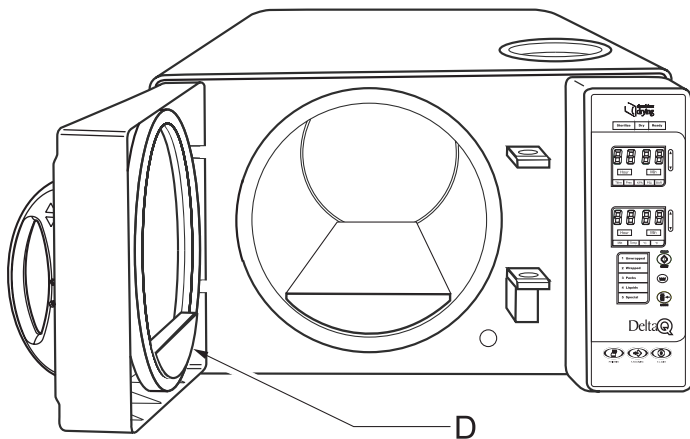

MAINTENANCE

Trouble Shooting Guide		
PROBLEM INDICATORS	PROBLEM CAUSE	CORRECTIVE ACTION
Mineral buildup on chamber wall or water spots on chamber and contents.	Minerals in water or on contents (using tap water).	Clean with Omni-Cleaner Plus® (part no. 30 06 934) following instructions on bottle. Scrub chamber with Bon-Ami® or Scotch-Brite®. Use distilled water only.
Unit takes an excessive amount of time (over 20 minutes from a warm start) to reach required sterilization temperature.	Load too large. Steam pushing out air too slowly. Leak in valves.	Remove some packages/articles for faster steam flow. Call authorized service representative.
Moisture evident in packs or wraps after drying cycle.	Overloaded chamber. Chamber tilted forward resulting in water left in chamber after venting. Fill line filter (inside chamber) clogged or not properly installed, resulting in too much water remaining in chamber after venting. Drying time not adequate for load. Drying air intake filter clogged. Drying pump not operating properly. Unit run without preheating.	Follow "Preparation and Loading" instructions (pg.12). Level unit properly. Refer to "Installation Instructions," (pg. 9) for proper unit leveling procedure. Clean filter in ultrasonic cleaner. Adjust fill line filter to center bottom of chamber. Replace if air and water cannot freely pass through filter. Increase drying time. (see Programming) Call authorized service representative. Call authorized service representative. Wait 30 minutes to start sterilizing cycle after power is turned on.
Wet layer in pack.	Inadequate drying air penetration due to tight pack wrapping or condensation from packs.	Inspect pack for proper wrap. Basins, kits and other utensils should be prepared as individual packs.  Caution: Use only approved packs.
Water collects in bottom of chamber when unit is not in "Fill" cycle.	Leaking fill / vent solenoid valve. Hole in condensing coil.	Call authorized service representative. Call authorized service representative.
Unit drips on counter from door during cycle.	Debris on gasket or door ring. Cut in gasket.	Clean gasket and door ring or replace gasket if cut.
Water comes out of fill opening on top of case when unit vents to reservoir.	Reservoir overfilled. Cracked condenser tube causing turbulence under fill opening.	Drain some water. Fill to bottom of openings in fill cup. Replace condenser tube.
Unit will not turn on.	No power to wall receptacle. Master power switch is not turned on. Defective electronics.	Reset building circuit breaker. Be sure main power switch/circuit breaker on back of unit is on. Call authorized service representative.
Dark stains on instruments.	Electroplating. Cold sterilization residue. Chlorine stains.	Do not mix dissimilar metals in the same package. Separate carbon steel, aluminum chrome and brass from stainless steel trays by using a tray liner. Wash thoroughly before loading. Do not use toweling or packaging which may contain chlorine bleach residue.
Chamber surfaces become cracked.	Chlorine.	NEVER use chlorine cleansers or materials in chamber. Wrapping materials should not be cleaned with chlorinated bleaches. Use only distilled water. Call authorized service representative.
Unit clicks, but no display; unit shuts off intermittently in mid-cycle.	Malfunctioning connector cable.	Call authorized service representative.
Door leaks on 10 inch autoclave.	Lip of tray rest is in front of the water dam.	Place lip behind water dam.
Instruments become rusted or stained.	Minerals and metals in reservoir or chamber.	Use only distilled or deionized water for autoclaving. Clean and flush reservoir/chamber.

MAINTENANCE









Trouble Shooting Guide

PROBLEM INDICATORS	PROBLEM CAUSE	CORRECTIVE ACTION
Positive biological indicator	<p>Insufficient steam penetration.</p> <p>Wrong type of biological indicator for this sterilizer, wrong cycle used or biological indicator has expired.</p>	<p>Reduce load weight or check if load is packed properly.</p> <p>Check biological indicator instructions to make sure indicator is for a gravity type sterilizer. Check that indicator is correct; one for cycle times and temperatures being run. If necessary, contact your biological indicator representative.</p>



WARNING: Do not use instruments if unit fails to complete cycle.

MAINTENANCE

CHECK DISPLAY	COMPONENTS CHECKED	OPERATIONAL FUNCTION CHECKED
	Fill/vent solenoid	Solenoid operation and electrical continuity.
	Dump solenoid	Solenoid operation and electrical continuity.
	Bellows solenoid	Solenoid operation and electrical continuity.
	Steam sensor	Electrical continuity and parameter check.
	Surface sensor	Electrical continuity.
	Battery	Parameter memory for specials mode (e.g., clock settings).
	Pressure transducer	Nominal operating parameter.
	Line voltage	Adequate voltage.

Self-Diagnostic Check

Automatic Check

The autoclave automatically performs a diagnostic self-check on nine key components for operational continuity each time the main power switch (toggle switch located at rear of unit) is turned on.

An additional check may be made by the following procedure:

Operational Check

Press “Power On”  switch and “Clear/Start” switch at the same time. The autoclave beeps once, signaling the beginning of the self-diagnostic procedure.

During the first four seconds, check that all display segments illuminate. If segments do not illuminate, call an authorized service representative. This problem can give the operator incorrect information if not repaired.







After self-diagnostics, the unit returns to stand-by. The lower window displays any error found during the Operational or Automatic self-diagnostic check procedure. See table at left for explanation of display.

Call an authorized service representative if an unsatisfactory check is indicated.

MAINTENANCE

Operating Alarms

Eight alarms can occur during a sterilization cycle. All alarms are indicated by a “beeping” sound for one minute (or until “Clear/Start” is pressed) and an alarm display in the lower display window. The alarm display will remain visible until the problem is corrected or until the “Clear/Start” button is pressed.

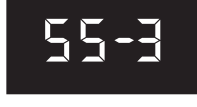
DISPLAY	CAUSE	ACTION
	Chamber door not fully closed. Problem with door switch.	Shut door properly. Check door switch (see Maintenance, pg. 14)..
	Not enough water in chamber. Chamber has boiled dry.	Inspect for clogged reservoir and chamber filter. Clean or replace filter as necessary. See that there is sufficient water in reservoir. Clear unit. Restart cycle. If problem recurs, turn off “Power” switch and call an authorized service representative.
	Not enough water in chamber. Leak in gasket. Failure to fill properly. Failure to seal against pressure. Chamber overloaded. More than 10-minute lapse during air bleeding process. Door opened during temperature rise. More than a 3-minute lapse during sterilization countdown.	Inspect for clogged reservoir and chamber filter. Clean or replace filter as necessary. Check door gasket and chamber sealing surface for debris or cuts and clean or replace as needed. Turn off “Power” switch and call an authorized service representative. Check chamber for proper loading and remove some packages/articles which may be impeding proper steam circulation. Check chamber for proper loading and remove some packages/articles which may be impeding proper steam circulation. Shut door properly. Clear unit. Restart cycle. If problem recurs, turn off “Power” switch and call an authorized service representative. Add distilled water to reservoir between cycles.
	Low water indicator.	Add or replace water in the reservoir.
	Defective pressure-sensing circuit.	Turn off “Power” switch and call an authorized service representative.
	Overpressure in the system.	Clear unit. Restart cycle. If problem recurs, turn off “Power” switch and call an authorized service representative.
	Temperature is less than 10° C. Defective steam sensor.	Let unit warm up before operating. Turn OFF power switch and call an authorized service technician.
	Steam temperature too high.	Turn off “Power” switch and call an authorized service representative.

OPTIONS

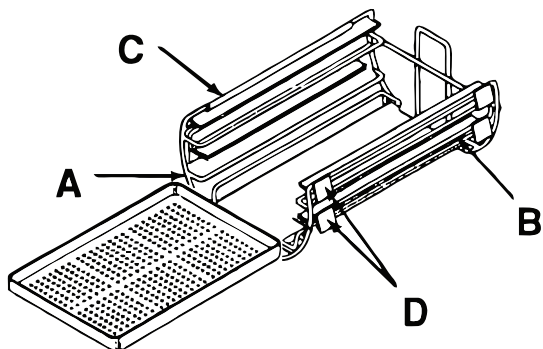

DELTA Q 8"

Tray Clip Installation for Additional Trays

To install additional European trays into 8" autoclave, first insert tray rack (A), then slide clips over middle (B) and top (C) tray rest rods and let the outside edges (D) of the lips rest against the wall of the autoclave. Tray rest will then hold four open trays.

Time/Temperature Printer P/N 041523.

The Time/Temperature Printer works in conjunction with the 8" and 10" model autoclaves to provide complete sterilization records of temperature, pressure and time of sterilization cycles.

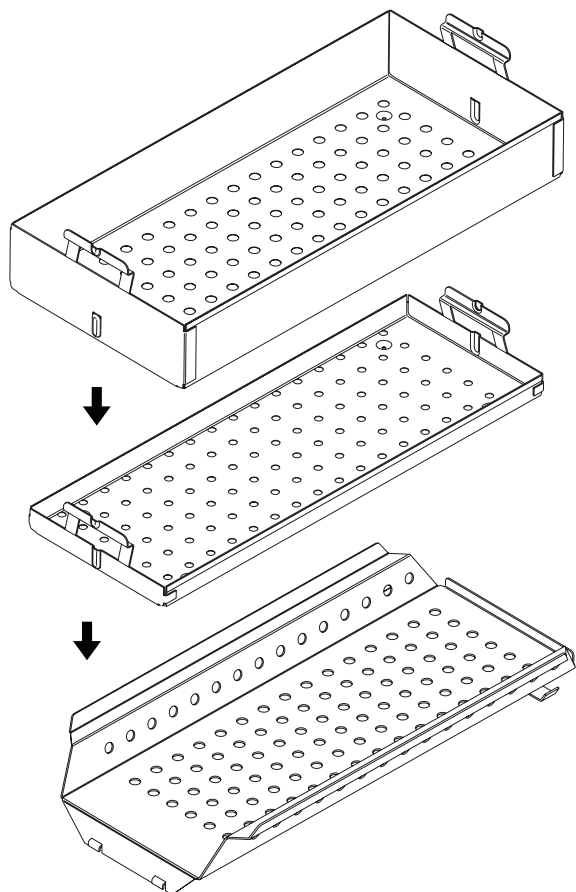

DELTA Q 10"

HU-Friedy/European Cassette Rack (P/N 024338) for 10" autoclave.
IV. European Cassette Rack (P/N 023554) for 8" autoclave.

INSTALLATION AND SERVICING CHECKLIST

Verify the following after installation or servicing of the unit if applicable:

- All manuals are present.
- All labels are present and legible.
- No mechanical damage on new installations.
- The chamber filter is positioned and touches the bottom center of the chamber.
- The unit is connected to the correct power source.
- The unit is setting on a level surface.
- The air tube inside the chamber is properly installed.
- The reservoir is full of distilled water only.
- When the clear/start switch is pressed the display comes on.
- The door latch opens and closes properly.
- When depressing the mode selection switch, the unit changes programs.
- While running the unit there is no water or steam leaking from the chamber or tubing.
- If optional printer is connected and after starting a cycle, the printer starts to print periodically through the cycle.
- The unit passes a Hi-Pot test.
- All terminals are connected securely.
- The filters are new.
- The unit passes a ground continuity test.
- The internal wiring is in good shape and not frayed.

