

Operation and Maintenance Manual

Pre-vacuum Steam Sterilizer
with Generator

LABSCI 15 LWS

First time published; 15.07.2019

HSG-MD: standard autoclave (manual door)
HSG-D: standard autoclave (automatic door)
BH: optional bio hazard filtration
WS: water recycling option

Cat. No. MAN205-0446008EN Rev I

☒ Heidolph North America , 1235 N Mittel Blvd. Suite B Wood Dale IL 60191
☎ Phone: 224-265-9600 ☒ Fax: 224-265-9611, e-mail:
service@heidolph.com

TABLE OF CONTENTS

1.	GENERAL	3
1.1.	INCOMING INSPECTION	3
1.2.	WARRANTY	3
1.3.	WARRANTY STATEMENT	4
1.4.	ORDERING INFORMATION	4
2.	SAFETY INSTRUCTIONS	5
2.1.	SAFETY FEATURES	5
2.2.	SAFETY INSTRUCTIONS.....	5
2.3.	OPERATING CONDITIONS	6
3.	GENERAL INFORMATION	6
3.1.	INTRODUCTION	6
3.2.	SPECIFICATION	7
3.3.	GENERATOR'S STEAM DATA	8
3.4.	GENERATOR'S ELECTRICAL DATA.....	8
3.5.	AUTOClave'S ELECTRICAL DATA (THE GENERATOR IS NOT INCLUDED).....	8
3.6.	UTILITIES	8
3.7.	ENVIRONMENTAL EMISSION INFORMATION	9
3.8.	CONSTRUCTION.....	9
3.9.	STICKERS DESCRIPTION	10
3.10.	STICKERS MAP -- LABSCI 15 LWS	11
3.11.	WATER QUALITY	11
3.12.	DIRECTIVES AND STANDARDS	13
3.13.	OVERALL DIMENSIONS LABSCI 15 LWS	14
4.	CONTROL PANEL	17
4.1.	DESCRIPTION AND FUNCTIONS OF THE CONTROL PANEL	18
4.2.	DISPLAYED ERROR MESSAGES / SYMBOLS	22
4.3.	DISPLAYED OPERATIONAL MESSAGES/ SYMBOLS	22
5.	STERILIZATION PROGRAMS	23
5.1.	PROGRAM PARAMETERS	23
5.2.	CYCLE PROCESS DESCRIPTION	24
5.3.	VACUUM TEST PROCESS DESCRIPTION.....	24
5.4.	BOWIE AND DICK TEST PROCESS DESCRIPTION	24
6.	INSTALLATION INSTRUCTION	25
6.1.	PLACING	25
6.2.	SETUP	25
6.3.	UTILITIES CONNECTION	25
6.4.	LIFTING AND CARRYING	25
6.5.	GENERATOR	26
7.	PREPARATION BEFORE STERILIZATION. LOADING	26
7.1.	GENERAL RULES TO BE CONSIDERED:	27
7.2.	PACKS	28
7.3.	TUBING	29
7.4.	WRAPPED INSTRUMENTS	29
8.	OPERATING INSTRUCTIONS	29
8.1.	WATER SUPPLY	29
8.2.	TURNING ON THE AUTOCLAVE.....	29
8.3.	WATER FILLING – LABSCI 15 LWS	30
8.4.	OPENING THE DOOR– D MODELS (AUTOMATIC DOOR).....	31
8.5.	STARTING A CYCLE	31
8.6.	ENDING THE CYCLE. UNLOADING	32
8.7.	STOPPING THE PROCESS MANUALLY.....	33

8.8.	STOPPING THE PROCESS DUE TO CYCLE FAILURE	33
9.	CHECKING AND CHANGING PARAMETERS	35
9.1.	QUICK OPTIONS SCREEN	35
9.2.	ENTERING THE MAIN MENU (LOGIN)	35
9.3.	SYSTEM PARAMETERS	36
9.4.	MAINTENANCE	36
10.	MAINTENANCE INSTRUCTIONS	36
10.1.	PREVENTIVE AND SCHEDULED MAINTENANCE	36
10.2.	CLEANING THE WATER OUTLET STRAINER	37
10.3.	REPLACING THE HEPA AIR FILTER	38
11.	TROUBLESHOOTING.....	38
12.	SPARE PARTS LIST	40

APPENDIX 1: Viruses Protection Cycle

Read the Operating Instructions carefully, before beginning any operation on the autoclave!

1.1. Incoming Inspection

Upon receiving your Tuttnauer Autoclave, carefully inspect the outside of the shipping carton for signs of damage. If any damage to the carton is found, note the location with respect to the autoclave and check that area of the autoclave carefully once it is fully unpacked. Observe packing method and retain packing materials until the unit has been inspected. Mechanical inspection involves checking for signs of physical damage such as: scratched panel surfaces, broken knobs, etc.

If any damage is found, contact your dealer as soon as possible so that they can file a claim with the shipping carrier and also notify Tuttnauer.

All Tuttnauer products are carefully inspected prior to shipment and all reasonable precautions are taken in preparing them for shipment to assure safe arrival at their destination.

Note: Lifting and carrying should always be done by two people.

1.2. Warranty

We certify that this instrument is guaranteed to be free from defects in material and workmanship for one year against faulty components and assembly with the exception of glassware, lamps and heaters.

The warranty does not include and does not replace routine treatment and preventive maintenance to be performed according to instructions in sec. 12.1 (Preventive Maintenance).

Our obligation is limited to replacing the instrument or parts, after our examination, if within one year after the date of shipment they prove to be defective. This warranty does not apply to any instrument that has been subjected to misuse, neglect, accident or improper installation or application, nor shall it extend to products that have been repaired or altered outside the factory without prior authorization from us.

The Autoclave should not be used in a manner not described in this manual!

1.3. Warranty Statement

To activate your warranty or for warranty information on this unit please contact your dealer or Heidolph at one of the #'s listed below:

☒ Heidolph North America, 1235 N Mittel Blvd. Suite B Wood Dale IL 60191

Service & Repair Division

Troubleshooting, Service incidents, Warranty repair, Repair, Services and Return authorization

☎ Phone: 224-265-9600 ☒ Fax: 224-265-9611, e-mail: service@heidolph.com

Tuttnauer USA Co., Ltd., 25 Power Drive Hauppauge, NY 11788, USA (800) 624 5836, (631) 737 4850, Fax: (631) 737 0720
e-mail: info@tuttnauerUSA.com.

Note:

If you have any questions or there are any difficulties with this instrument and the solution is not covered in this manual, please contact your dealer or Heidolph.

Do not attempt to service this instrument yourself.

If there is any difficulty with this instrument, and the solution is not covered in this manual, contact our representative or us first. Do not attempt to service this instrument yourself. Describe the difficulty as clearly as possible so we may be able to diagnose the problem and provide a prompt solution.

If the autoclave is equipped with a printer, send along a copy of the last printout for our inspection. If replacement parts are needed, stipulate the model and serial number of the machine.

No products will be accepted for repair without proper authorization from us. All transportation charges must be paid both ways by the owner. This warranty will be void if the unit is not purchased from an authorized full service **Tuttnauer** dealer.

1.4. Ordering Information

Several items must be specified when ordering the unit from your dealer.

- The chamber diameter and chamber depth required
- Please specify the supply voltage available (i.e. 115v/208v; 1Ph/3Ph)
- The temperature scale needed (Celsius or Fahrenheit).
- The pressure scale needed (kPa or psi)

The autoclave has unique characteristics. Please read and understand the operation instructions before first operation of the autoclave. This manual includes instructions of operation, the door safety mechanism, dangers involved in circumventing safety means, how to ensure that the door is closed, and how to select a correct sterilization program.

Never use the autoclave to sterilize corrosive products, such as: acids, bases and phenols, volatile compounds or solutions such ethanol, methanol or chloroform nor radioactive substances.

2.1. Safety features

The autoclave has the following features for hazard protection:

The pressure vessel chamber door has the following features protecting personnel from hazards:

1. Two door switches that indicate that the door is closed and locked. Without this indication steam is not introduced to the chamber.
2. A pressure switch that blocks door opening if the pressure is higher than 20% above the ambient pressure.

These features are implemented in the following devices (limiters):

For the chamber:

1. Electrical door lock
2. Mechanical membrane door lock
3. Mechanical safety valve (1 for chamber and 1 for generator).

For the generator:

1. Cut-off pressure switch
2. Cut-off thermostat

The main power is shut off if there is lack of water or the pressure is above the safe level.

Below are the safety instructions:

2.2. Safety Instructions

1. All autoclave users must receive training in proper usage from an experienced employee. Every new employee must undergo a training period under an experienced employee.
2. When sterilizing plastic materials, make sure that the item can withstand sterilization temperature. Plastic that melts in the chamber is liable to cause a great deal of damage.
3. On closing the device door, make sure it is properly locked before activating. Verify that DOOR OPEN  symbol is replaced by the load number.
4. When withdrawing trays, wear heat resistant gloves.
5. Before opening the door, verify that the pressure in the chamber equals the atmospheric pressure (chamber pressure is displayed on the screen).
6. Unlock the door properly: see 8.4 (HSG-D) and **Error! Reference source not found.** (HSG-MD) respectively.
7. Open the door the minimum required to let the residual steam to escape from the chamber. Only after there is no vapor, open the door widely and remove the load.

8. Once a month, ensure that the safety valve is operating, and once a year certified inspector must perform pressure chamber safety test.
9. Once a year, or more frequently, effective tests must be performed, i.e., calibration and validation.
10. Make sure there are no leaks, breaks, blockages, whistles or strange noises.
11. Perform maintenance operations as instructed. The owner of the autoclave is responsible to perform the maintenance operations.
12. Notify the person in charge immediately of any deviation from the proper function of the device.
13. Protective equipment and clothes and other safety instructions should be implemented in accordance with local and national regulations and/or rules!
14. This autoclave equipped with rear and front wheels, when moving the autoclave all utilities must be disconnected, at least 2 persons shall move the autoclave with caution. When the autoclave located in the required place, the wheels have to be locked. For further information see FRONT/REAR VIEW of the autoclave.

2.3. Operating Conditions

1. This device is for indoor use only!
2. The sterilizer should be loaded only with autoclavable material!
3. Do not use the autoclave in the presence of dangerous gases.
4. Minimum room ventilation shall be 10 cycles per hour.
5. The environment shall not exceed an ambient temperature range of from 5°C (41°F) to 40°C (104°F) and a relative humidity of 85% respectively.
6. The operational altitude shall not be over 2000 meters (6562 feet) (ambient pressure shall not be lower than 80 kPa (11.6 psia)).
7. Operate the autoclave only in the manner specified in the manual. If the equipment is used in a manner not specified by the manufacturer, the protection provided by the equipment may be impaired.

Caution!



Waste water should be brought into the public net in accordance with the local rules or requirements

ONLY NON-HAZARDOUS LIQUIDS SHALL BE DISPOSED IN PUBLIC SEWAGE!

3 General Information

3.1. Introduction

The LABSCI 15 LWS horizontal autoclave is designed for sterilization of wrapped and unwrapped instruments, and related items found in veterinary clinics, first aid rooms, laboratories etc.

This autoclave is a steam-heated sterilizer using steam as the sterilizing agent. A computerized control unit ensures a fully automatic sterilization cycle, control and monitoring of physical parameters and a clear documentation of the sterilization cycle.

The autoclave offers a choice of automatic programs designed to match the material to be sterilized. The autoclave is equipped with a vacuum pump (HSG-D/HSG-MD models only) that during the drying stage draws air through a HEPA filter (0.2µm) and pushes that air through the heated chamber to remove moisture and facilitate the drying operation. **Drying is performed with the door closed.**

This autoclave is equipped with a vacuum system. The advantages of the prevacuum sterilizer in comparison to the regular gravity displacement steam sterilizer are as follows:

- Removal of air pockets from packs and porous load and most kinds of tubes (rubber, plastic etc.) by vacuum at the first stage of the cycle.
- Better steam penetration into the load; resulting in effective sterilization.
- Better temperature uniformity.

An 18kW/9kW built-in steam generator supplies the steam for the sterilization process.

The HSG-D series features a digital display for monitoring and control purposes. The device is capable of displaying the pressure in psia, psig, or in kPa according to the operator's requirements. When the pressure is displayed in psig, the atmospheric pressure is shown (at sea level) as 0 psig. If the pressure is defined in psia or kPa the absolute zero is displayed as "0" and the atmospheric pressure is shown (at sea level) as 14.7 psia or 100 kPa respectively. The HSG-D can display temperature in °F or °C.

A printer is a standard addition to the autoclave. The printer prints the preset and actual parameters of the cycle (temperature, time and pressure).

The HSG-D features built-in memory to record up to 100 sterilization cycles. These can be reprinted on the printer or exported to a USB device to be transferred to a PC.

WS models include the option of water recycling. You can manually fill the tap water reservoir with water that will be reused for 10 cycles. For 3870HSG-WS-D, every 10 cycles the reservoir is automatically drained and, if you use a water inlet connection, refilled.



Caution!

Only technical personnel having proper qualifications and holding technical documentation (including a technician manual) and adequate information are authorized to service the apparatus.

3.2. Specification

Property		LABSCI 15 LWS
Chamber	Diam.	38cm
	Depth	68.5cm
Chamber volume		85 liters
Max. Allowable Working pressure (MAWP)		2.8bar
Net weight		318kg
Shipping weight		340
Floor loading requirements		According to the Overall weight and floor requirements
Max load		Max. unwrapped load:18kg, max. wrapped load: Inside pouches – 8kg, Inside a container- 14kg.
Tray dimensions	Big	35 x 67 x 2.5 cm
	Small	28 x 67 x 2.5 cm
No. of trays		2
Load No. counter		Counting from 0 to 9999 and nullifies.

3.3. Generator's Steam Data

Property	18kW	9kW
Max. working pressure	3 BarG	3 BarG
Safety relief valve	5 Bar	5 Bar

3.4. Generator's Electrical data

Voltage	3 ph, 400V
Frequency (Hz)	50/60 Hz, depending on your country standard
Generator Consumption	27A (18kW), 13A (9kW) (
Autoclave Consumption (the generator is not included)	3A
Heaters	18kW/9kW

3.5. Autoclave's Electrical data (the generator is not included)

Voltage	3 ph, 230V
Frequency (Hz)	50/60 Hz
Consumption	3A
Total power	400W
Degree of protection by enclosure	IP31

3.6. Utilities

Property	LABSCI 15 LWS	
Electric Power Supply	Power Supply	3Ph, 400V,50/60Hz depending on your country standard
	Recommended circuit breaker	20A (9kW)
	Line current	16A (9kW)
	Protection against electrical shock	Class I (IEC 60601-1)
Mineral-free water inlet	1/2", 1-3 Barg	
Tap water inlet	1/2", 2-5 Bar	
Drain	1/2" withstanding temp. of 80°C	

- A switch or circuit-breaker must be included in the building installation. This switch or circuit-breaker shall be in close proximity to the equipment, within easy reach of the operator; and marked as the disconnecting device for the equipment.
- The electrical net must be protected with a current leakage safety relay.

- The electrical network must comply with local rules or regulations.
- Verify that there is an easy access to the main power switch, to the water cut-off valve and to the current leakage safety relay.
- Make sure while placing the autoclave, to leave space around the machine, to give the technician access to service the machine.
- All water connections to autoclave must be performed through "BACK FLOW PREVENTION SYSTEM" only, as per IEC 61770.

Cautions!



In order to avoid any injury by electrical hazard, it is recommended that a ground fault protection device (GFCI) be installed in the electrical panel feeding the autoclave (local codes may make this mandatory).

The electrical network must comply with local rules or regulations.

Verify that there is an easy access to the main power switch and to the current leakage safety relay (GFCI). The voltage supplied to the device must comply with the label $\pm 5\%$.

Note: The electrical network must comply with local rules or regulations.

Verify that there is an easy access to the main power switch and to the current leakage safety relay (GFCI). The voltage supplied to the device must comply with the label $\pm 5\%$.

3.7. Environmental Emission Information







1. The peak sound level generated by the autoclave is 70dBa with background noise of 60dBa.
2. The total heat per hour transmitted by the autoclave is <300Wh.

3.8. Construction

The main parts of the autoclave are made of materials as indicated below:

- Chamber is built of stainless steel 316 L.
- Door is made of stainless steel 304.
- Pressure vessel is made of stainless steel 316L.
- Cabinet is made of stainless steel 304
- Trays are made of stainless steel 316L.
- Generator's vessel is made of stainless steel 304/316L.
- Door closing handle is made of aluminum material, which is safe to touch and thermo-insulated.

3.9. Stickers Description

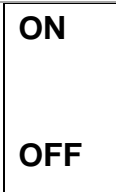
Symbol	Meaning	Part Number	Location
	Caution! Hot steam.	LAB048-0058	Near the safety valve
	Protective earth (Ground)	LAB048-0020	Near the on/off switch
	Caution! Hot surface.	LAB048-0023	On the rear cover above the water strainer
	Press & Hold Until "System Ready" is Displayed = 10 sec.	LAB048-0461 (Automatic door only)	On the door right edge
	Don't Touch Microswitches please Contact Tuttnauer Service	LAB048-0462	On the door frame behind the door cover
	Don't Touch Microswitches please Contact Tuttnauer Service	LAB048-0463	On the door frame behind the door cover
	On-Off	LAB048-0018	Near the Power switch

3.10. Stickers map -- LABSCI 15 LWS

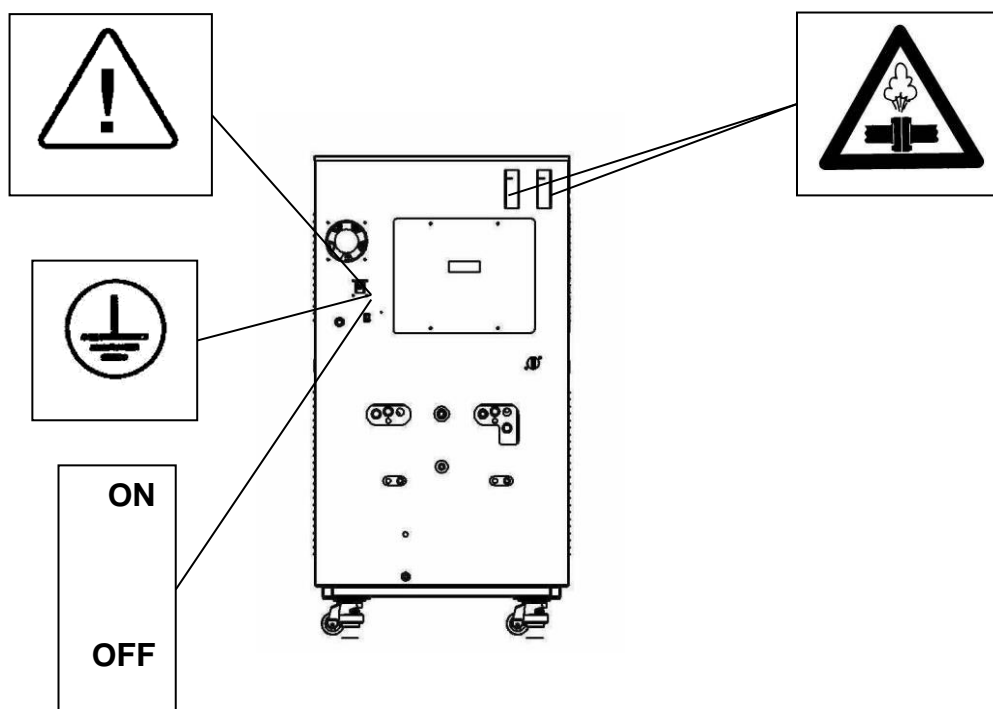

3.11. Water Quality

The distilled or mineral-free water supply shall be according to the table below:

Physical Characteristics and Maximum acceptable contaminants levels in water or steam, for steam generator and sterilizers

	Contaminants in water supplied to generator/chamber	Contaminants in condensate at steam inlet to sterilizer
Evaporate residue	≤ 10 mg/l	N/A
Silicate (SiO ₂)	≤ 1 mg/l	≤ 0.1 mg/l
Iron	≤ 0.2mg/l	≤ 0.1mg/l
Cadmium	≤ 0.005 mg/l	≤ 0.005 mg/l
Lead	≤ 0.05 mg/l	≤ 0.05 mg/l
Rest of heavy metals except iron, cadmium, lead	≤ 0.1 mg/l	≤ 0.1 mg/l
Chloride (Cl)	≤ 2 mg/l	≤ 0.1 mg/l
Phosphate (P ₂ O ₅)	≤ 0.5 mg/l	≤ 0.1 mg/l
Conductivity (at	3 to 15 μs/cm	≤ 3 μs/cm

25°C)		
pH value (degree of acidity)	5 to 7.5	5 to 7
Hardness (Σ ions of alkaline earth)	≤ 0.02 mmol/l	≤ 0.02 mmol/l
Appearance	Colorless, clean, without sediments	

Compliance with the above data should be tested in accordance with acknowledged analytical methods, by an authorized laboratory.

Attention:

The use of water for autoclaves that do not comply with the table above may have severe impact on the working life of the sterilizer and can invalidate the manufacturer's guarantee.

Use only deionized water, having a maximum conductivity of 15 $\mu\text{s/cm}$. Conductivity greater than 15 $\mu\text{s/cm}$ may cause failures.

Tap water supply

The range of hardness value 0.7-2.0 mmol/l (70- 200 mg/l CaCO_3)

The use of soft water is strictly forbidden!

Please consult a water specialist!

3.12. Directives and Standards

Every autoclave meets the provisions of the following Directives and is in compliance with the following Standards:

Tuttnauer. Ltd. company meets the provisions of the following standards:

EN ISO	13485:2012 (Quality Systems for Devices)
ISO	9001:2008 (Quality Systems)
MDD	93/42/EEC (Device Directive)

Tuttnauer. Ltd. company also works in conjunction with and refers to:

AAMI/ANSI-ST8	Hospital sterilizers
ASME	American Society of Mechanical Engineers Section VIII, Division 1, for unfired pressure vessels.
EN 285	Large Sterilizers
UL	UL 61010-1
PED	97/23EEC
IEC	IEC 61010-2-040 Safety
IEC	IEC 61326-1 EMC
ISO	17665-1:2006 (Validation and Routine Control)

3.13. Overall Dimensions LABSCI 15 LWS

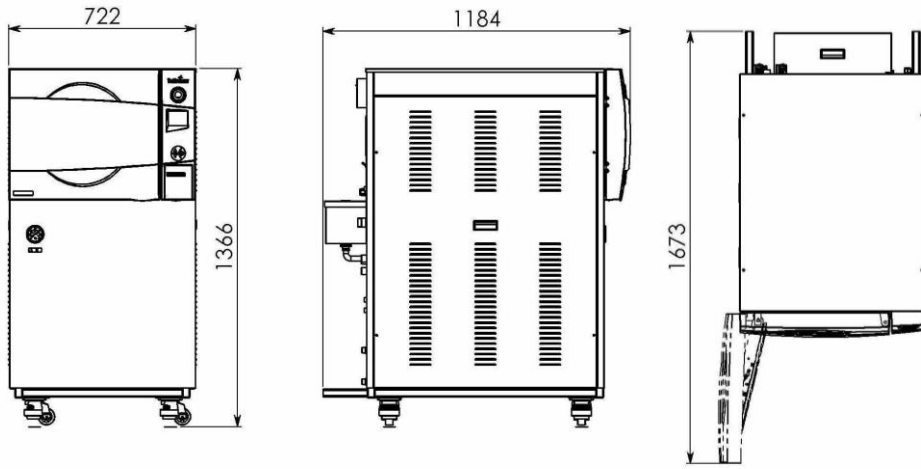

FRONT VIEW – LABSCI 15 LWS

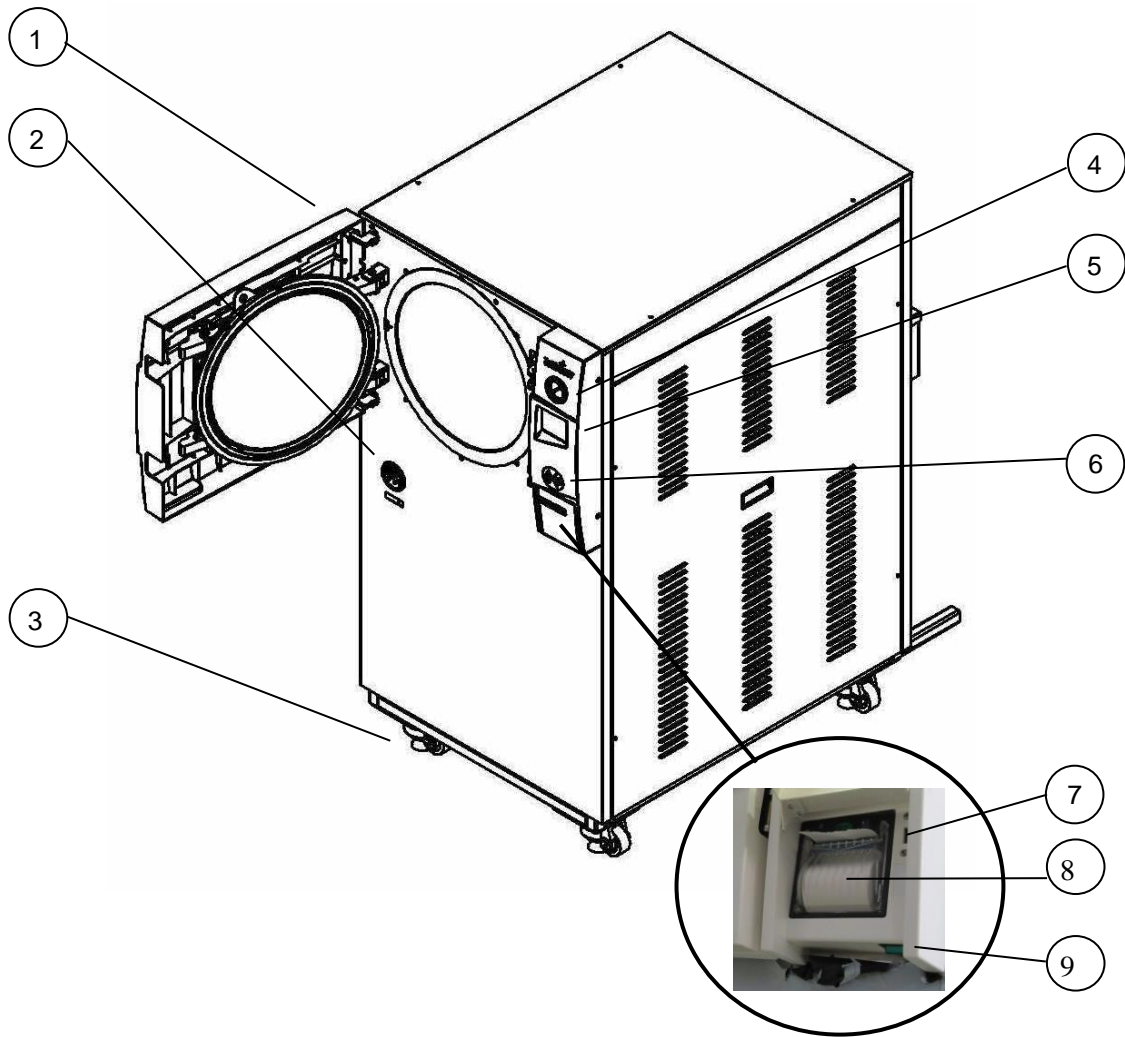

No.	Description	No.	Description
1	autoclave door	6	keypad
2	generator pressure gauge	7	USB port
3	wheel	8	printer
4	chamber pressure gauge	9	on/off switch
5	display		

REAR VIEW – LABSCI 15 LWS

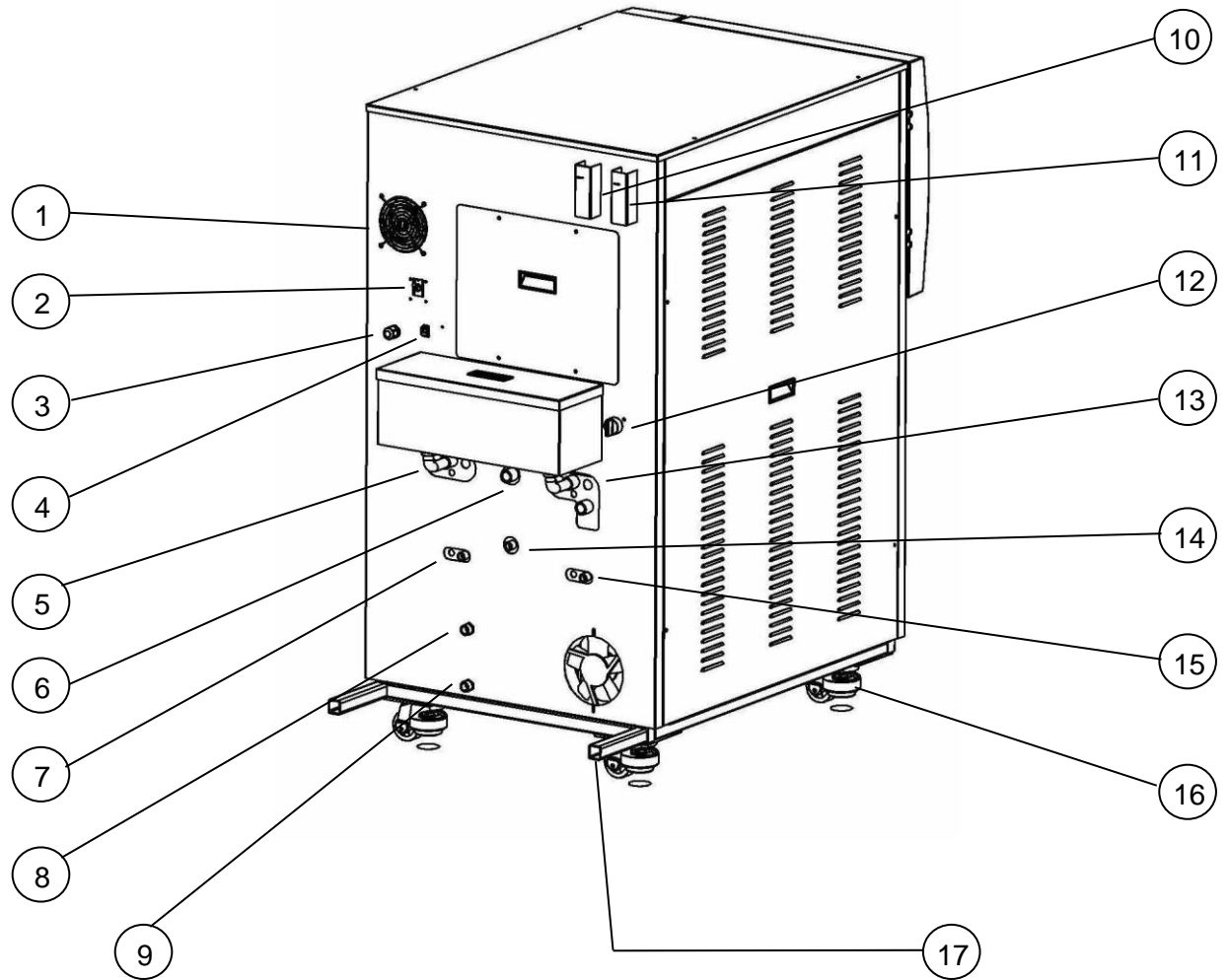

No.	Description	No.	Description
1	fan	10	chamber safety valve
2	circuit breaker	11	generator safety valve
3	power cable socket	12	fast exhaust strainer
4	network port	13	Tap water reservoir. Left opening - overflow, leave open. Right opening – inlet, an optional connection.
5	Mineral-free water reservoir. Left opening - overflow, leave open. Right opening – inlet, an optional connection.	14	chamber drain (optional)
6	chamber drain reservoir overflow	15	tap water reservoir drain
7	Mineral-free water reservoir drain	16	wheel
8	Feed water automatic drain(for automatic refill)	17	bumper rod
9	generator drain		

4 Control Panel

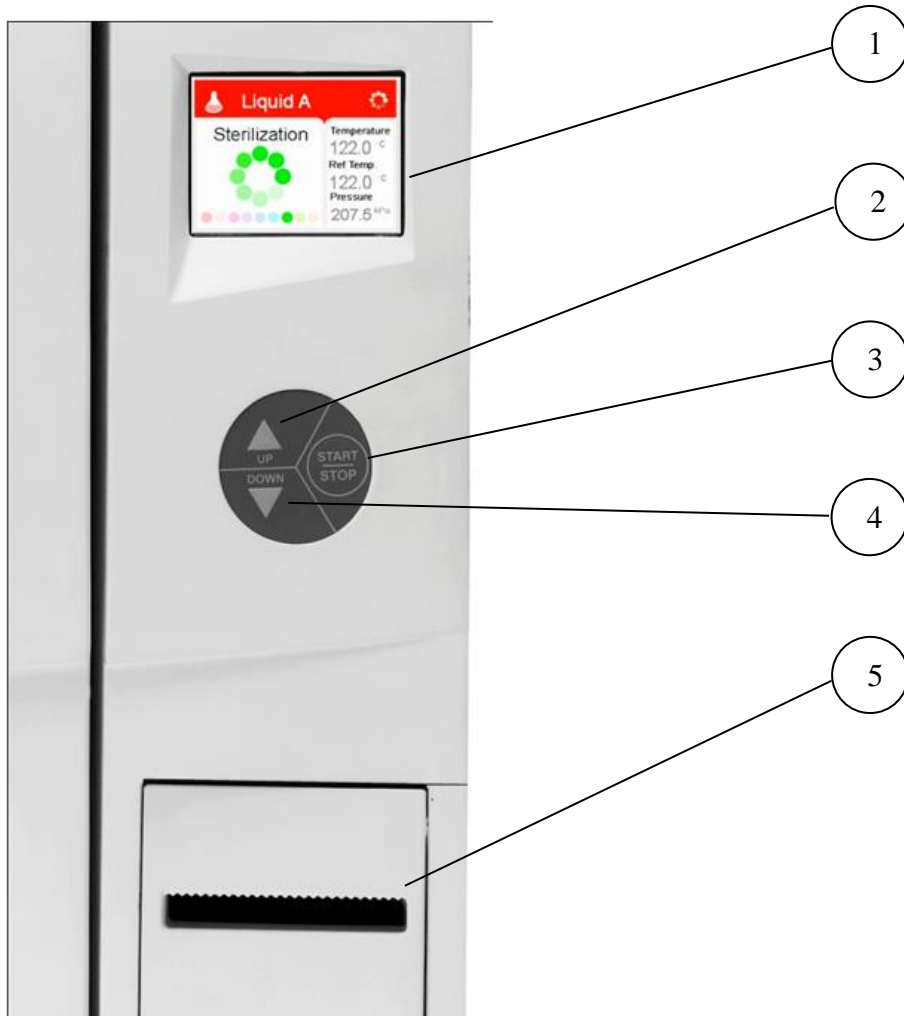

No.	Description
1	Display
2	Keypad: Up Button
3	Keypad: Start/Stop Button
4	Keypad: Down Button
5	Printer

4.1. Description and Functions of the Control panel

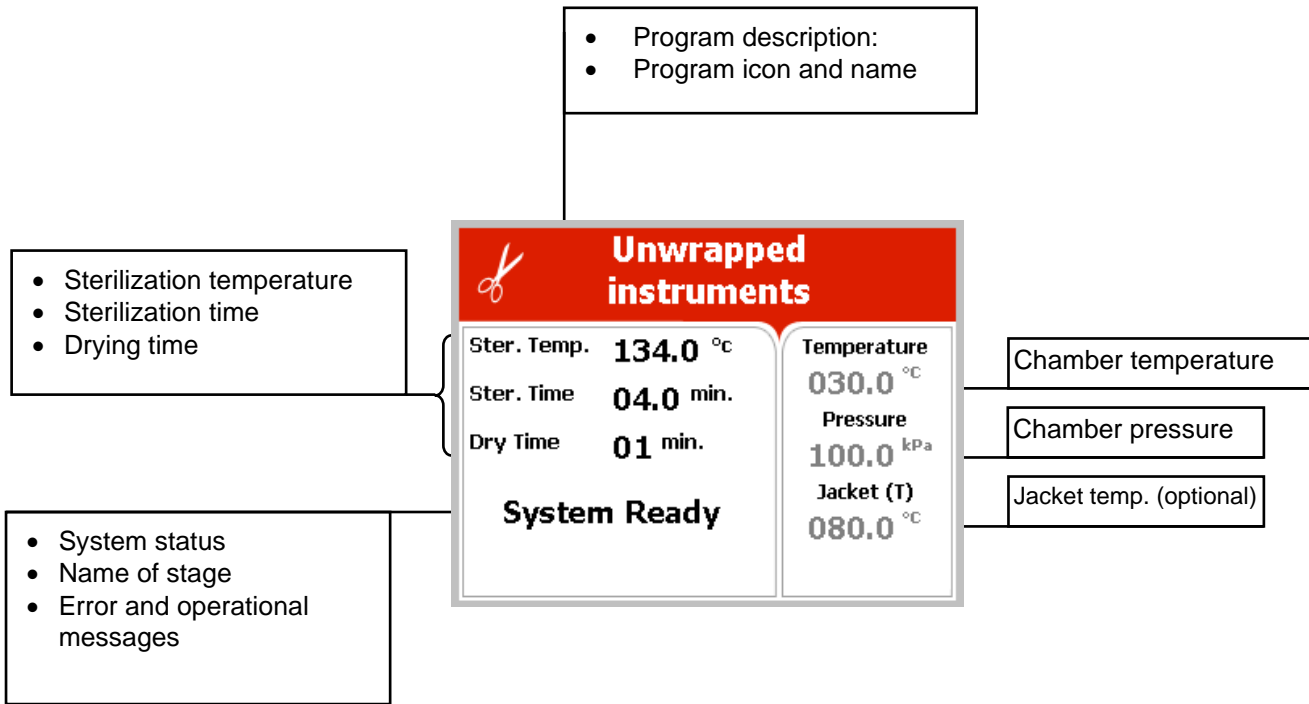

Display

The display is an LCD panel used to display the current status of the autoclave and any Operational Messages or Error Messages.



Keypad

The keypad consists of 3 keys as described below:

	<p>UP key</p> <p>This key has the following functions:</p> <ul style="list-style-type: none"> • In the menu directories: <ul style="list-style-type: none"> ○ This key enables the operator to browse through the cycles. • In the directories available: <ul style="list-style-type: none"> ○ When the cursor is blinking on a number, the UP ▲ key increases its value. ○ When the cursor is blinking on a menu selection, the UP ▲ key allows browsing backward through the menu. ○ When adjusting a parameter and the cursor is blinking on "SET" or "EXIT" the UP ▲ key activates that procedure.
	<p>DOWN key</p> <p>This key has the following functions:</p> <ul style="list-style-type: none"> • In the menu directories: <ul style="list-style-type: none"> ○ This key enables the operator to browse through the cycles. • In the directories available: <ul style="list-style-type: none"> ○ When the cursor is blinking on a number, the DOWN ▼ key decreases its

	<p>value. When the cursor is blinking on menu selection, the DOWN ▼ key allows browsing forward through the menu. When adjusting a parameter and the cursor is blinking on "SET" or "EXIT" the DOWN ▼ key activates that procedure.</p>
	<p>START/STOP key</p> <p>This key has the following functions:</p> <ul style="list-style-type: none"> • In the main screen: <ul style="list-style-type: none"> ○ Starts the process when the required program was chosen. ○ Stops the current process. ○ Cancels the ERROR message displayed on the screen and releases the electric door lock. • In the menu directories: <ul style="list-style-type: none"> ○ When the cursor is blinking on a number, the START/STOP ⓘ key enables moving to the next position. ○ When the cursor is blinking on a menu selection, the START/STOP ⓘ key activates that selection.

Printer

The printer prints the detailed history of each cycle performed by the autoclave. The printing is on thermal paper with 24 characters per line. It records the sterilization cycle information for subsequent consideration.

The printing is on thermal paper with 24 characters per line and contains the following information:

- | | |
|--------------|-------------------|
| • Date: | • Cycle: |
| • Time: | • Ster Temp: |
| • Ser. Num: | • Ster Time: |
| • Model: | • Dry Time: |
| • Version | • End Temperature |
| • Cycle Num: | |

When the sterilization cycle begins the printer starts printing the above data.

After the preliminary printing, the autoclave starts performing the sequence of operations of the cycle. The measured values of temperature and pressure are printed at fixed time intervals, according to the phase of the process from the bottom up, beginning with the date and ending with "Cycle Ended". For an aborted cycle, "Cycle Failed" and the Error message are printed (refer to "Displayed Error Messages/Symbols").

Printer Handling

Maintenance

Wipe off any soiling on the printer surface with a dry soft cloth with a weak neutral detergent. After that, wipe the printer with a dry cloth.

Setting paper

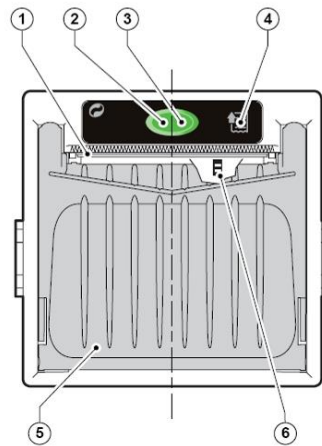

Printer model PLUS II Front view

- 1-Paper mouth
- 2-STATUS Led
- 3-OPEN key (for paper roll compartment opening)
- 4-FEED key
- 5-Paper roll compartment
- 6-Paper end sensor

Fig. 1

1. Open the printer's cover door by pulling it at the left bottom (see fig. 2).



Fig. 2

2. Press the OPEN key to open the printer cover as shown (see Fig. 3/1). Handle the paper cutter carefully not to cut your hand.
3. Place the paper roll making sure it unrolls in the proper direction as shown (see Fig. 3/2).
4. The paper should roll off the top of the roll
5. Hold the loose end of the paper with one hand and re-close the cover with the other hand as shown (see Fig. 3/3) the printer cover is locked.
6. Tear off the exceeding paper using the jagged edge (see Fig. 3/4).

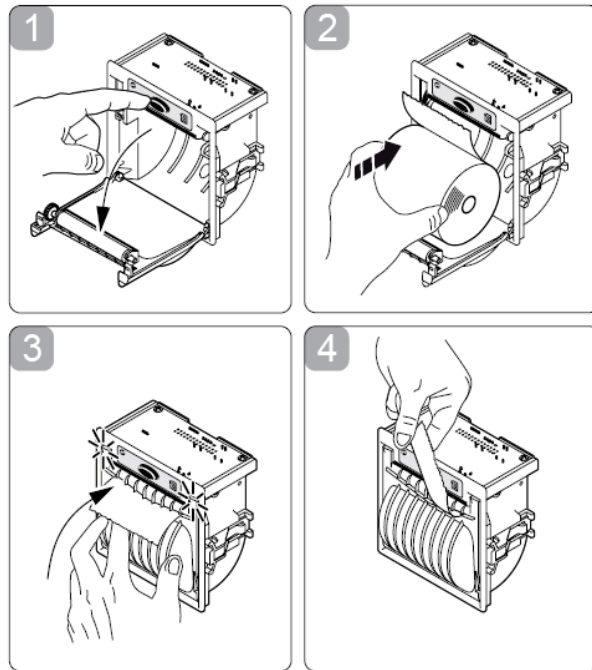

Fig. 3

7. Close the printer's cover door (3) by pressing corner (2), with the tip end of the paper emerging from the slot (1). See Fig. 2.

Notes on treatment of thermal papers:

- Store the papers in a dry, cool and dark place.
- Do not rub the papers with hard substance.
- Keep the papers away from organic solvent.



Caution!

Never disassemble the printer. Failure to follow this instruction may cause overheating or burning of the printer or the AC adapter. Or an electric shock, which may lead to fires or accidents.



Cautions!

Never use the printer in a place of extreme humidity or any place where it can possibly be splashed by any liquids. If any liquids get into the printer, it could lead to fire, electric shock, or other serious accidents.

Never touch the thermal head immediately after printing because it becomes very hot. Make sure that the thermal head is cool before setting papers or cleaning the thermal head.

Power OFF the autoclave in any of the following cases:

- The printer does not recover from an error.
- Smoke, strange noise or smells erupt from the printer.
- A piece of metal or any liquid touches the internal parts or slot of the printer.



4.2. Displayed Error Messages / Symbols

The failures are divided into two categories:

- Failures that occur before completing the sterilization stage, which in this case will leave the load unsterilized
- Failures that occur after completing the sterilization stage, which in this case will leave the load sterilized





For the list of *Displayed Error Messages / Symbols*
see 11 TROUBLESHOOTING

4.3. Displayed Operational Messages/ Symbols

Message / Symbol Name	Message / Symbol Description	Required Action
	This symbol is displayed when the door is open.	Close the door.
"Door is open"	This message is displayed when the door is opened: In stand-by, if start key is pressed.	Close the door to perform a new cycle. If the problem persists, call the technician.
"Cycle Ended"	This message is displayed when the cycle ended successfully.	Press START/STOP in order to perform a new cycle.
"Test Ended"	This message is displayed when the test ended.	Press START/STOP in order to perform a new test
	This symbol is displayed when Cycle by Clock mode is active.	Enter the main menu as described in this manual to change the time or to cancel this option.
	This symbol is displayed when the temperature in the jacket did not reach the preset value	Wait until the temperature in the jacket reaches the preset value
"System is not ready to run a cycle.Cycle by clock is active"	This message is displayed if the user presses START/STOP key while the "start cycle by clock" mode is active. Starting another cycle is not allowed.	Enter the main menu as described in this manual to change the time or to cancel this option.
"Atmospheric pressure not set"	This message is displayed in order to set the atmospheric pressure by opening the door for 2 minutes.	Open the door for 2 minutes in order to set the Atmospheric pressure.
"Please restart machine in order for changes to be updated"	Changes to the system software require that the autoclave be restarted.	Restart the autoclave in order for changes to be updated.

5 Sterilization Programs

5.1. Program Parameters

Program	Icon	Name	Temp	Sterilization time (minutes)	Dry time (minutes)
1		Unwrapped 134	134°C (270°F)	4	1 (default) Range: 1-99
2		Wrapped 134	134°C (270°F)	7	20 (default) Range: 20-99
5		Unwrapped 121	121°C (250°F)	20	1 (default) Range: 1-99
6		Wrapped 121	121°C (250°F)	20	20(default) Range: 20-30
7		Prion	134°C (273°F)	18	20(default) Range: 0-99
8		Vacuum test		Vacuum test	
9		Bowie & Dick test	134°C	3.5	2

During the process, the stages of the cycle will be displayed on the screen:

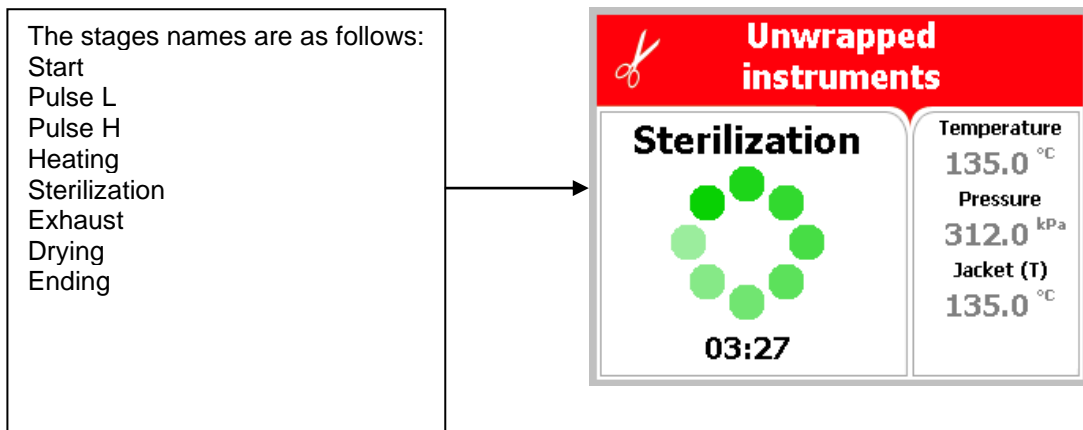

Note: The control system incorporates a safety feature that prevents changing programs if the door is closed .

This protection is intended to prevent running an inappropriate program if the autoclave is loaded, but the cycle is not immediately started .

If the operator for example inserts the load into the chamber, closes the door and leaves the room and another operator/user tries to change the program, the operator/user will not be able to do this unless the door is opened and the type of load inside the chamber can be seen. The autoclave offers four preprogrammed sterilization programs

Using the UP/DOWN keys enables the user to select the programs

5.2. Cycle Process Description

- Air-removal stage; vacuum pulses are performed .
- Heating stage: steam is inserted into the chamber until the sterilization temperature is reached .
- Sterilization temperature is maintained constant during the sterilization time.
- Fast exhaust, steam is exhausted out of the chamber at a fast rate until pressure decreases to ambient pressure.
- For Wrapped 134 and Wrapped 121. Drying by heating of chamber and air circulation to remove leftover moisture from the instruments and wraps.

5.3. Vacuum Test Process Description

- Vacuum is produced in the chamber, down to P1=7 kPa. At this stage all the valves close. The autoclave remains in this stage for 5 minutes. This period enables the condition in the chamber to reach equilibrium.
- After the 5 minutes have elapsed the printer records the pressure that is referred to as P2. At this point the test begins and lasts 10 minutes.
- At the end of the test, the printer records the results. The pressure at the end of the test is referred to as P3.

Notes: During the test period the autoclave is not heated. During the test period the screen color is purple. If the vacuum test failed, the screen color changes from purple to yellow. If the vacuum test is completed, the screen color will remain purple. Even if the vacuum test is completed, the operator shall check the test results and consider whether the test results are acceptable or not

5.4. Bowie and Dick Test Process Description

- Air-removal stage: vacuum pulses are performed.
- Heating stage: steam is inserted into the chamber until the sterilization temperature and pressure are reached.
- Sterilization stage: temperature and pressure are maintained constant at the pre-set level for sterilization time.
- Fast exhaust stage; steam is exhausted out of the chamber at a fast rate until pressure decreases to ambient pressure.
- Drying stage; heating of chamber followed by a vacuum break (air inlet) to remove leftover moisture from the instruments and wraps. Air inlet to reach atmospheric pressure.

Notes: If the B&D test cycle failed, the screen color changed from purple to yellow
If the B&D test cycle ended successfully "Test Ended" message will display and the screen color will remain purple.

6.1. Placing

Make sure while placing the autoclave, to leave space around the machine, to give the technician access to service the machine. Keep the back and the right side of the autoclave approximately 2" (50mm) away from the wall to allow for ventilation.

At the time of installation or anytime the unit is relocated the atmospheric pressure parameter needs to be reset. (See 9.4).

Connect the power cord to the socket on the rear side of the autoclave; plug it into the supply outlet. The autoclave must be connected to a properly grounded outlet.

6.2. Setup

- Make sure all the feet are on the autoclave and none of them has been lost
- Fill the reservoir with mineral-free water (see 8.3)
- The unit is ready to operate.

6.3. Utilities connection

- If the autoclave is intended to operate with water inlet and drain outlet connected to the facility's utilities, connect the following:
 - a. Connect the autoclave to the source of mineral-free water through a flexible ½" hose. Mount a manual valve on the source of the water supply, in order to enable closing the water inlet for maintenance or servicing purposes.
 - b. **(WS models only)** Connect the feed water automatic drain to the building's drainage pipe. The drainage shall be of an open type, withstanding temperature of, at least, 80°C. If you wish to use the autoclave without drain connection, put a bucket under the feed water automatic drain.
 - c. Connect the feed water supply to the tap water inlet. The supplied water pressure shall be set to 2-4bar. Mount a manual valve on the source of the water supply, in order to enable closing the water inlet for maintenance or servicing purposes.

6.4. Lifting and Carrying

Cautions!

Before moving the autoclave, Make sure that the electric cord is disconnected from the power, and there is no pressure in the chamber.



1. Disconnect the power supply cord.

2. Drain the water from the reservoir and the chamber (open the water drain valve (see Rear View) and pour the water to a bucket)

Do not drop the device!

6.5. Generator

After installation and prior to putting the machine into operation, the following preparing and checkout procedure for the generator is to be fulfilled:



Warning!

When servicing the autoclave, disconnect all the electrical power supplies to the unit. This is done by switching OFF the main power supply switch, or by unplugging the electrical power main supply cords.

- Check the connection to local sewage. Check that the sewage pipeline is not clogged. (Pour water for this task).
- Check the connection to compressed air, pay attention to the door, set the pressure to 6-8 bar.
- Check the connection to tap water. Open the water valve. Manually test the water valves by over-riding the appropriate solenoid valve. If there are no leaks – rotate backwards the solenoid by-pass. Leave the manual inlet taps open.
- Check the connection to mineral-free water. Open the water valve. Test manually the water valves by over-riding the appropriate solenoid valve. If there are no leaks, rotate backwards the solenoid by-pass. Leave the water manual inlet taps open.
- Open the generator electric box, switch ON the 3 Phase circuit breaker with its Trip Coil, and ensure all the other circuit breakers are ON.
- Check that the jacket pressure gauge, reaches 2.4 bar. Press the Test button mounted on the generator electric box to de-activate the internal steam generator.
- Switch ON the 3 Phase circuit breaker with its Trip Coil, and ensure all the other circuit breakers are ON.
- Check that the Microbiological Filter Cover is removed.
- Check the connection to electricity – To be performed by an authorized electrician only!

7 Preparation before Sterilization. Loading

The most important stage begins with removing debris by **cleaning** and rinsing. Effective cleaning is affected by several factors: Water quality, type, concentration and quality of a cleaner, an effective washing method and adequate rinsing and drying.

Cleaning dried **blood** is especially difficult because it flows and dries in difficult-to-clean locations. It must be washed away. Mechanically scrubbing, high pH detergents, enzymatic solutions and water spray at high pressure will clean this contamination.

Attention: Consult the Device manufacturer relating adequate and most effective cleaning method and cleaning agents.

Instruments which are composed of several components shall be dismantled.

Disinfection is the next step. It is important for safe handling. There are various methods and means for disinfection like soaking in liquid chemical disinfectants or hot water disinfection.

Packaging. The target in packing items is to assure that the contained goods are sterile and maintaining them sterile till opening the package.

There are various methods and techniques used in preparation and packaging of surgical instruments.

7.1. General rules to be considered:

1. The packaging materials should be held in the room ambient conditions (temperature and humidity) for at least 2 hours.
2. The packaging materials should be examined regularly for defects.
3. Procedures should be established to assure that packaging is consistent with the manufacturer's recommendations.
4. Policy whether to wrap in single or double layer, woven or non-woven should be established.
5. Container systems should be scientifically proven to suit the specific sterilization cycle.
 - Paper-paper bags are used for safe post sterilization handling. Usually as single wrap. Intended for small, lightweight and low profile instruments.
 - Paper-plastic pouches, single or double packing is intended for longer storage period. In case of double packing, two sequentially sized packs should be used. No folding is permitted. They should be placed so that plastic faces plastic and paper faces paper. Paper-plastic pouches shall not be wrapped or contained.
 - Textile packs. The barrier properties of new textile wrap are diminished by repeated laundering and sterilization cycles. They shall be inspected for holes, worn spots breaks, stains or separation of the fabric.
 - Non-woven. Unique materials like paper or Polypropylene as single layer or as "Double wrap single layer. It is tear resistant and is for single use.
6. Immediately after surgery use, clean instruments thoroughly to dispose of any residue or immerse it in enzymatic disinfectant.
7. It is recommended to wash instruments with an ultrasonic cleaner, using detergent and mineral-free water.
8. Launder textile wraps prior to reuse.
9. After cleaning, rinse instruments for 30 seconds. (Follow manufacturer's instructions on the use of products for cleaning and lubricating instruments after using the ultrasonic cleaner).
10. Materials, including materials used for inner wraps, shall be compatible with the item being packed and the sterilizing method selected.
11. Do not place materials to be sterilized directly on the chamber's wall. Place the material only on trays, rack, etc.
12. Before placing an instrument into the sterilizer tray, make sure that instruments which are not of the same metal, (stainless steel, carbon steel, etc.) are separated and placed on different trays.

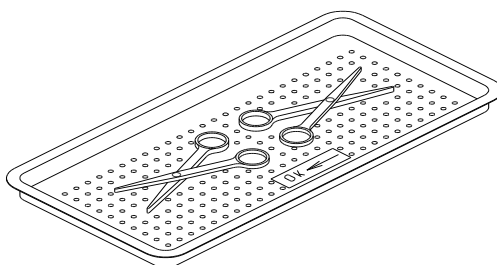

13. Place empty containers upside down to prevent accumulation of water.
 14. Before use, check inside the autoclave chamber to ensure that no items have been left from the previous cycle.
 15. Do not overload the chamber or the trays.
 16. Use only autoclavable products. Please refer to the manufacturer instructions for sterilization of unknown materials or instruments.
- Note:** Check manufacturer's instructions for the sterilization of each item.
17. Observe maximum weight limits as referenced in the table in 3.2
 18. All instruments must be sterilized in an open position.

19. Use single-use wraps only once and discards them after use.
20. In case carbon steel instruments are placed on stainless steel trays, the trays should be lined with a towel or paper wrap before placing the instruments on the trays. There should be no direct contact between the carbon steel and the stainless steel trays.
21. Verify that the packaging method is in accordance with good practice approach and the packaging materials are in accordance with the applicable standards (e.g. EN868 series).
22. Place a sterilization indicator strip (Class 4) in each tray.
23. Place instruments with ratchets opened and unlocked or clipped on the first ratchet position.
24. Disassemble or sufficiently loosen multiple-part instruments prior to packaging to permit the sterilizing agent to come into contact with all parts of the instrument.
25. Tilt on edge items prone to entrap air and moisture, e.g. hollowware, so that only minimal resistance to removal of air, the passage of steam and condensate will be met.
26. Load items within the boundaries of the tray so that they do not touch the chamber walls, or fall off when the tray is in move.
27. The operator may use racks to allow for adequate separation of packaged instruments.
28. Load trays in such a way as to allow steam to move freely among all items.
29. Allow a distance of approximately 2.5 cm (1") between trays to permit steam circulation.
30. Once a week, use a biological spore test indicator in any load to make sure sterilization is performed.
31. Make sure that all instruments remain apart during the sterilization cycle.
32. Empty canisters should be placed upside-down, in order to prevent accumulation of water.

7.2. Packs

1. Place packs upright on trays, side by side.
2. Packs should not touch the chamber walls.
3. Pack instrument sets in a manner that prevents damage to delicate items.
4. Pack hollowware sets so that all openings face the same direction and so that the contents cannot move inside the pack.
5. Load packs of folded operating room drapes with layers vertical, allowing air to be removed from the packs rapidly.
6. Do not place packs of hollowware and trays of instruments above textile packs or soft goods in order to avoid wetting caused by condensation from items above.
7. Do not stack pouches. It is recommended that a Tuttnauer™ Pouch Rack be used. This will allow the operator to place pouches on their side, which will increase capacity and provide proper spacing to ensure steam penetration and promote adequate drying.
8. Load items packed in flexible packaging materials on edge with paper to laminate, or flat with the paper surface upwards.

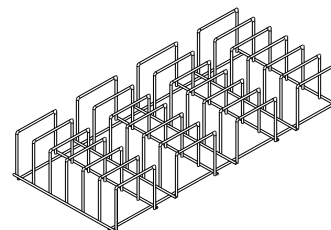
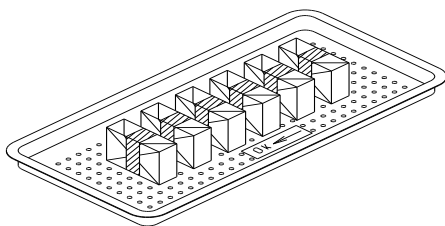

Note: The manufacturer's recommendations shall be observed, concerning the sterilization data for each type of material.

7.3. Tubing

Rinse tubing after cleaning with pyrogen free water. When placing in a tray, Make sure that both ends are open, without sharp bends or twists.

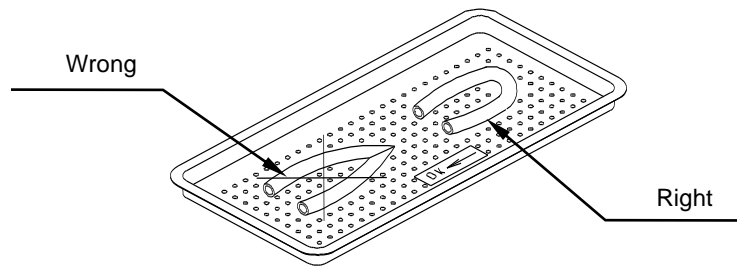

7.4. Wrapped Instruments

1. Wrapped instruments should be packed in material that promotes drying such as autoclave bag, autoclave paper.
2. Use single-use wraps once only and discard after use.
3. It is highly recommended to utilize the Tuttnauer™ Pouch Rack. This rack allows the operator to place pouches on their side, thus increasing the capacity of the autoclave significantly and promoting better drying of the instruments. Contact your dealer for details.
4. Verify that the packaging method is in accordance with good practice approach and the packaging materials are in accordance with the applicable standards. We recommend using plastic-paper pouches.

8 Operating Instructions

8.1. Water Supply

1. If the autoclave is connected to external water supply, open the manual valves of the tap water supply and mineral-free water supply.
2. If the autoclave is not connected to external water supply (WS models), verify that the tap-water reservoir and the mineral-free water reservoir are full. (see 8.3).

8.2. Turning on the Autoclave

1. Plug the power cord into the back of the autoclave and into the wall outlet.
2. Turn on the rocker switch (1), located behind the printer's door.

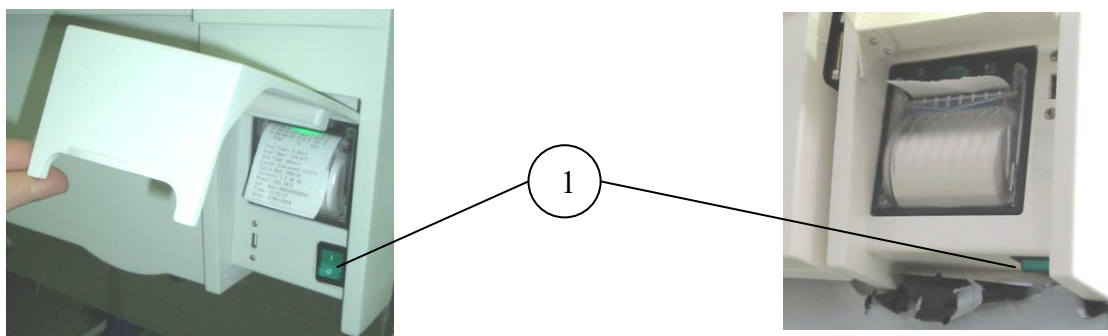

3. When running the autoclave for the first time, set date and time (see , 9.1 Quick Options Screen, Set Date and Time).

8.3. Water filling – LABSCI 15 LWS

The operator must fill the tap water reservoir and the mineral-free water reservoirs before operation.

Note: To prevent contamination of the water, the tap water reservoir must be emptied and refilled every 10 cycles (or once a day if you make less than 10 cycles a day). In 3870HSG-WS model the reservoir is automatically drained every 10 cycles.

1. Remove the cover (4) of the tap water filling funnel (2) and the mineral-free water filling funnel (3).
2. Pour water in the appropriate funnel until the float in the water level gauge reaches the required height.
 - The float of the tap-water reservoir (1) must reach the middle of the level gauge tube.
 - The float of the mineral-free water reservoir (5) must reach the top of the level gauge tube.
3. Return the cover of the funnels to its place.

3870HSG-WS

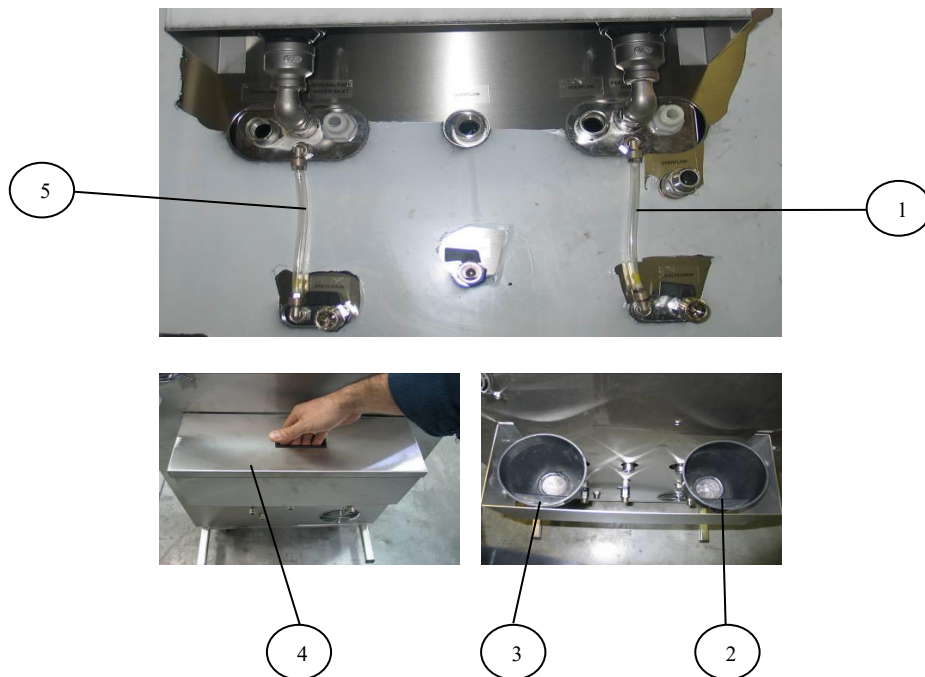

8.4. Opening the door– D models (automatic door)

When the door is locked, the system prompts: “System Ready” Press ^ to open”:

1. Press the  Key in order to unlock the door. The system prompts: “Wait... Door Opening”.

If the door unlocks successfully, the following screen will be displayed:

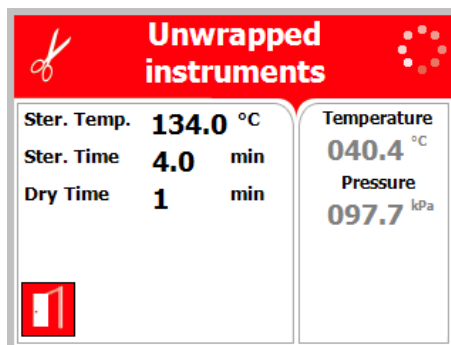

8.5. Starting a cycle

1. Load the autoclave properly (see 7)
2. Use the UP/DOWN keys to select the program to run.
3. If the autoclave is equipped with a printer verify that a paper roll is inserted in the printer. If not - insert as shown in 4.1.

Note: The program can only be changed when the door is open.

4. Close the door.

D models (automatic door)

When the door is open, the following screen is displayed:

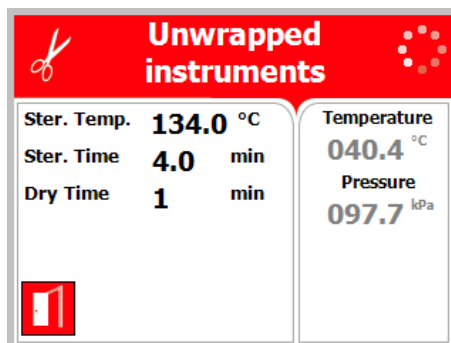

- a. Close the door:



Warning!

In order to close and lock the door push the door to the wall of the autoclave chamber (for about 10 seconds) until the "System Ready" message appears as shown below!



While closing the door the system prompts: "Wait... Door Closing".

When the door is properly closed, open door symbol  is replaced by the message "System Ready" Press ^ to open".

5. For the 5075HSG-WS models, drain and refill the feed water (vacuum pump) reservoir once after 20 cycles. To do so, open the feed water reservoir drain valve (see Rear View, 7) and pour the water to a bucket, then refill the reservoir manually (See 8.3).
6. Start the cycle by pressing the START/STOP key.

For the cycle description, see 5.2.

Note: For the LABSCI 15 LWS model, the tap water reservoir is automatically drained every 10 cycles (this process takes 10 minutes approx.). If you press Start during these 10 minutes, the system will inform you that the cycle will start in 10 minutes.



Caution!

Do not touch the strainer's cover, mounted on the exhaust line, during and short after operation.

Touching the hot strainer's cover may cause severe injuries

8.6. Ending the Cycle. Unloading

When the cycle has ended successfully (including the user pressing the START/STOP key after the sterilization stage has finished) the message "Cycle Ended" is displayed.

In the event of a failure, after completing the sterilization stage, the message "Cycle Ended" and the relevant failure message is displayed on the screen.

Pressing the START/STOP key will clear the "Cycle Ended" message or any error message and unlock the door.

1. Verify that there is no pressure in the chamber, according to the reading on the display, and that "System Ready" is displayed. Only then may the door be opened.
2. To release the door locking at the end of operation, press the UP key. The same applies at power up after fail. Unlock the door properly: see 8.4 (D models) and **Error! Reference source not found.** (MD models) respectively. Open the door the minimum required to let the residual steam to escape from the chamber. Only after there is no vapor, open the door widely.



Warning!

To avoid severe injuries from hot steam when opening the door: it is strictly forbidden to lean on the autoclave. It is strictly forbidden to place your hand or any part of your body over the door.

3. On completion of the cycle, the load shall be visually inspected to ascertain that the load is dry, and that sterilization indicators have made the required color change.
4. At the end of each working day close the main water valve.



Warnings:

The sterility of the instruments processed in unwrapped cycles cannot be maintained if exposed to non-sterile environment.

Don't touch the strainer's cover, mounted on the exhaust line, during and shortly after operation. It will get very hot.

Touching the hot strainer's cover may cause severe injuries.

To avoid severe injuries from hot steam when opening the door, it is strictly forbidden to lean on the autoclave or to place your hand or any part of your body over the door.

8.7. Stopping the Process Manually

It is possible to stop the program while the autoclave is operating. Pressing the START/STOP key at any stage of the process stops the operation.

If the cycle was aborted before completing the sterilization stage, it will leave the load unsterilized. If the cycle is aborted before completing the sterilization stage, a yellow caution screen is displayed with a caution symbol, the message "Cycle Failed", and an error message explaining the reason for the failure.

Pressing the START/STOP key cancels the displayed message and unlocks the door so it can be opened.



Warnings:

The sterility of the instruments processed in unwrapped cycles cannot be maintained if exposed to non-sterile environment.

Don't touch the strainer's cover, mounted on the exhaust line, during and shortly after operation. It will get very hot.

Touching the hot strainer's cover may cause severe injuries.

To avoid severe injuries from hot steam when opening the door, it is strictly forbidden to lean on the autoclave or to place your hand or any part of your body over the door.

The load has not completed a sterilization cycle, therefore it is not sterile. Handle it as contaminated load.

8.8. Stopping the Process due to Cycle Failure

- The cycle can stop itself if the unit detects a problem
- If the cycle is aborted prior to completing the sterilization stage, a yellow caution screen is displayed with a caution symbol, the message "Cycle Failed", and an error message explaining the reason for the failure.
- Pressing the START/STOP key cancels the displayed message and unlocks the door so it can be opened.



Warning:

The load has not completed a sterilization cycle, therefore it is not sterile.

Handle it as contaminated load.

9

Checking and Changing Parameters

9.1. Quick Options Screen

1. When the system is ready, enter the QUICK OPTIONS screen by pressing the UP and DOWN keys simultaneously.

Note: To exit every screen do one of the following:

- move the cursor to Exit by pressing UP or DOWN keys and then press START/STOP key.
- press the UP and DOWN keys simultaneously.

On this screen you can either proceed to login (see 9.2) or choose one of the quick options available without login.

Add Extra Dry Time

This quick option allows changing the Dry Time parameter for the current cycle.

1. On the Quick Options screen, move the cursor to Add extra dry time.
2. Press the START/STOP key.
3. Choose the time value to be added, and press START/STOP key.
4. The time shown on the screen will be added to the current value and you will return to the cycle main screen.
5. For example, if the dry time was 2 min., and you chose 10 minutes on the Add Dry Time screen, the dry time for the current cycle will be 12 minutes.

Note: In order to return to the default dry time value, enter the Add Extra Dry time screen and choose zero value.

Set Date and Time

This quick option enables the operator to set date and time.

1. On the Quick Option screen, choose Set Date And Time. Time and date are displayed.
The time is displayed in the upper row in the form "HH:MM:SS". The hour range is 24 hour (i.e. from "0" to "24")
The date is displayed in the lower row in the form "DD: MMM: YYYY".
2. To increase or decrease the time or the date use the UP or DOWN keys.
3. To move the cursor from one digit to another press the START/STOP key.
4. After changing the time and the date, by pressing the START/STOP key move the cursor to Set.
5. When the cursor is on Set, confirm the new time and date by pressing UP or DOWN keys.

9.2. Entering the Main Menu (Login)

1. When the system is ready, enter the QUICK OPTIONS screen by pressing the UP and DOWN keys simultaneously.
2. On the Quick Options screen, choose login.
3. Press the UP or DOWN keys to move the cursor to Admin.
4. 0000 is displayed on the screen with the cursor blinking on the right digit.
5. To increase or decrease the digits, press the UP or DOWN keys.
6. After changing the code to 0001 move the cursor to Set by pressing the START/STOP key.

7. When Set is blinking, press the UP or DOWN keys to enter the MAIN MENU of the autoclave.
8. To browse through the directories, use the UP or DOWN keys.
9. When the required directory is blinking, press the START/STOP key. The required screen will be displayed.

9.3. System Parameters

Screen Saver

This subdirectory enables the operator to set the screen saver time.

The default time value is 90 minutes. It is possible to increase or decrease the time value up to a maximum of 600 minutes or down to a minimum 0 minutes.

1. On the Main Menu, choose System Parameters\ Screen Saver.
2. When entering the Screen Saver screen, the time will be displayed. The cursor is blinking on the "minute" digit.
3. The time is displayed in the form "0000" min.
4. To increase or decrease the digits, press the UP or DOWN keys.
5. After changing the value move the cursor to Set by pressing the START/STOP.
6. When Set is blinking, press the UP or DOWN keys in order to confirm changes and return to the previous screen.

9.4. Maintenance

Reset Atmospheric Pressure

1. This subdirectory allows to reset the atmospheric pressure.
2. On the Main Menu, choose Maintenance\ Reset Atmospheric Pressure.
3. The following message appears on the screen: "Reset done! New value will be set after door is open for 2 minutes and the temperature is less than 045.0 °C".

10 Maintenance Instructions

10.1. Preventive and Scheduled Maintenance

The maintenance operations described in this chapter need to be followed as indicated to keep the device in good working condition.

The instructions that follow can easily be carried out by the operating personnel and do not require a service technician.

Note: Technician manual describes the maintenance operations required from qualified technician, every two months and once a year.

Should the need arise, technical assistance or a service technician can be requested by calling your dealer.

Daily

- Clean door gasket with a mild detergent, water and a soft cloth or sponge. The gasket should be clean and smooth.
- In 3870HSG-WS-D model, the reservoir is automatically drained every 10 cycles.

Weekly by the operator

- Empty and refill the vacuum pump reservoir.
- Put a few oil drops on the 2 door pins and door tightening bolt.
- Clean the outer parts of the autoclave with a soft cloth.
- Clean and descale the chamber.

Periodically by the operator

- Once per month clean the water outlet strainer (see 10.3). Cleaning frequency may be reduced according to experience.
- Check the door gasket every 12 months and replace it if required (see Technician manual).
- Replace the air filter, every 6 months or after 1000 cycles (whichever comes first) according to sec. 12.3 .

10.2. Cleaning the Water Outlet Strainer



Cautions!

Before proceeding, Make sure that the electric cord is disconnected and there is no pressure or water in the chamber.

Warnings!

1. The strainer's cover is HOT

Do not touch the strainer's cap, mounted on the exhaust line, during and shortly after operation. Touching the hot strainer's cap may cause severe injuries.

2. If maintenance operation is performed while strainer cap is hot, use heat resistant gloves to avoid injuries.



1. Open the strainer cap.
2. Remove the strainer element.
3. Rinse the strainer with water, using a brush if necessary.
4. Reinstall the strainer element.
5. Close the strainer cap.

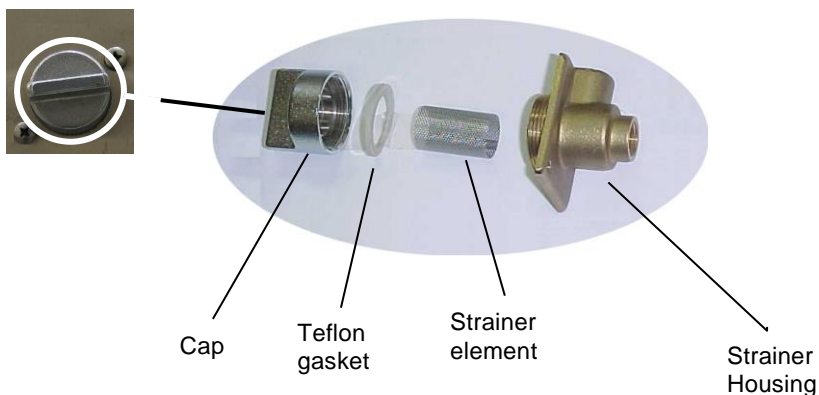

10.3. Replacing the HEPA Air Filter



Caution!

Before proceeding, make sure that the electric cord is disconnected and there is no pressure in the autoclave.

The HEPA filter is located on the back of the autoclave. (See Rear View (7)).

1. Pull out the filter cover. The filter cover is held in place by plastic tabs. Rotate the cover until the tabs release, the cover will come off and the filter will come out.
2. The filter and cover are pressed together. Place two fingers between the filter and the cover and while supporting the cover pull the filter and cover apart.
3. Insert a new filter by pressing it into the filter seat.
4. Replace the filter cover.

Note: make sure that the arrow on the filter body points inwards, toward the chamber. Make sure that you don't bend the filter pipe when reattaching the cover.



Note: It is recommended to replace the HEPA filter, every 6 months or after 1000 cycles (whichever is the shorter period).

11 Troubleshooting

Only technical personnel having proper qualifications and holding technical documentation (including a technician manual) and adequate information are authorized to service the apparatus.

Problem/ Error Message	Message / Symbol Description	Corrective Action
Display is not activated	The main switch is in the off position. The power cord is not connected properly to the machine and the power source. There is no electrical power in the main source.	Turn the main switch on. Make sure the power cord is properly connected to the machine and the power source. Fix the electrical power supply.
The printer does not print, or it prints, but nothing is printed on the paper	The paper is not inserted correctly in the printer.	Make sure the paper is inserted in the printer correctly. See 4.1, Printer handling Switch the machine off then back on. If the printer prints the date and time, the printer is O.K.
"Chamber temperature not in range"	This message is displayed if the temperature in the chamber is too high or too low from the normal range.	Wait until the the chamber reaches the normal range temperature.
"Chamber pressure not in range"	This message is displayed if the pressure in the chamber is too high or too low from the normal range.	Wait until the the chamber reaches the normal range pressure.

Problem/ Error Message	Message / Symbol Description	Corrective Action
"RTC Error - Please Set Current Date and Time"	This message is displayed , only for the first time when the autoclave is turned on, in order to set the date and the time.	Set Current Date And Time. If the problem persists, call the technician.
"Door is open (During the cycle)"	This message is displayed when the door is open: During the cycle.	Close the door to perform a new cycle.
"Canceled By User"	This message is displayed after the START/STOP key is pressed and cycle aborted.	Wait until "cycle failed – canceled by user" or "cycle end – canceled by user" is displayed. Perform a new cycle.
"Air Error"	This message is displayed at the end of the cycle if the autoclave does not reach the atmospheric pressure after 10 minutes.	Wait until the autoclave reaches the atmospheric pressure and perform a new cycle.
"Power Down"	This message is displayed if power down has occurred during the cycle. (this message will print out in the printer after the autoclave will turn on).	Turn on the autoclave and wait until the autoclave is ready (reaches the safe condition) and perform a new cycle.
"System is not ready to run cycle: Cleaning reservoir vacuum pump. Please wait 10 minutes.	This message is displayed, in autoclaves with WS option only, when, after every 10 cycles, the water pump reservoir is automatically drained and, if you use a water inlet connection, refilled. This process may take up to 10 minutes.	Wait until the message disappears, then run the cycle.

The following messages require you to check that your autoclave is not overloaded:

- "Heat Time Error"
- "Heat Time Error (Keep)"
- "Pressure Time Error"

The following messages require you to perform a new cycle:

- "Low Temp"
- "High Temp"
- "Low Pressure"
- "High Pressure"
- "High Pressure (Ending)"
- "High Pressure (Exhaust)"
- "High Pressure (Dry)"
- "Pressure Time Error"
- "Cycle Failed"

The following messages require you to call for service:

- "Analog Input Error"
- "Time Error"
- "Periodical check time exceeded - Please call for service"
- "Cycle counter exceeded - Please call for service"

The following messages require you to turn the autoclave off and on again, and if the problem persists, to call for service.

- "I/O Card Failed"
- "I/O card is not connected"

12 Spare Parts List

Part number LABSCI 15 LWS	Description
FIL175-0027	Strainer Cap
FIL175-0046	Strainer Screen
GAS082-0008	Silicon Strainer Gasket, 4mm
CMT387-0112	Water reservoir cover
TRY387-0002	Big tray
TRY387-0004	Small tray
TRH387-0002	Tray holder

APPENDIX 1: Viruses Protection Cycle

APPENDIX 1: Viruses Protection Cycle

The Viruses Protection Cycle for autoclaves include:

Program 5: Viruses Protection Cycle

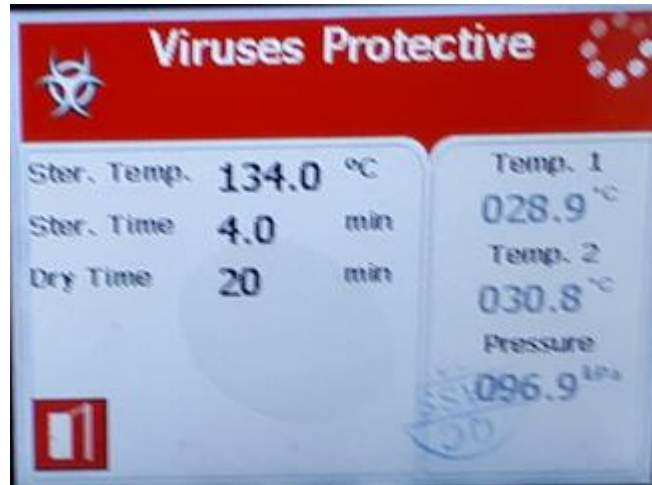

For wrapped instruments, pouches and materials, when the instrument manufacturer recommends autoclaving at temperatures of 273.2°F (134°C) with a drying stage.

With additional Virus inactivation step = “stable” stage will be added prior to the sterilization cycle and will consist a pre-heating time frame (15min @ 103°C) without exhausting air to the environment. The designed step more than doubles the time required for the inactivation of the virus that is exposed to the target temp (15min @ 103°C).

The addition of the “stable” stage will be added to the approved cycle and after this step the cycle B/S class will continue the same without any change. This means that there is no change to the regulatory approved and validated sterilization cycle.

Nominal parameters default settings

Sterilization temperature: 273.2°F (134°C)

Sterilization time: 4 minutes

Drying time: 20 minutes (may be increased by the operator (see sec. 5.1.1), other parameters are set and cannot be altered).

Operations sequence:

- Stable 0 Stage: Insert steam to the chamber until temperature of above 103°C is achieved and keep the temperature for 15 minutes.
- Air-removal stage: a series of vacuum pulses are performed.
- Heating stage: steam is injected into the chamber, from the steam generator, until the sterilization temperature is reached
- Sterilization phase: temperature and pressure are maintained constant at the pre-set level during the sterilization time.
- Fast exhaust: steam is exhausted out of the chamber at a fast rate until pressure decreases to ambient pressure.
- Drying phase: a continuous vacuum along with heating of chamber to efficiently and quickly dry the instruments.
- Drying is followed by a vacuum break so chamber pressure can equalize to atmospheric pressure.