

Barrier-Free[®] Examination Table



Service and Parts Manual

Model Numbers:

222 -001 thru -017

223 -001 thru -016

622 -001 thru -008

623 -001 thru -010

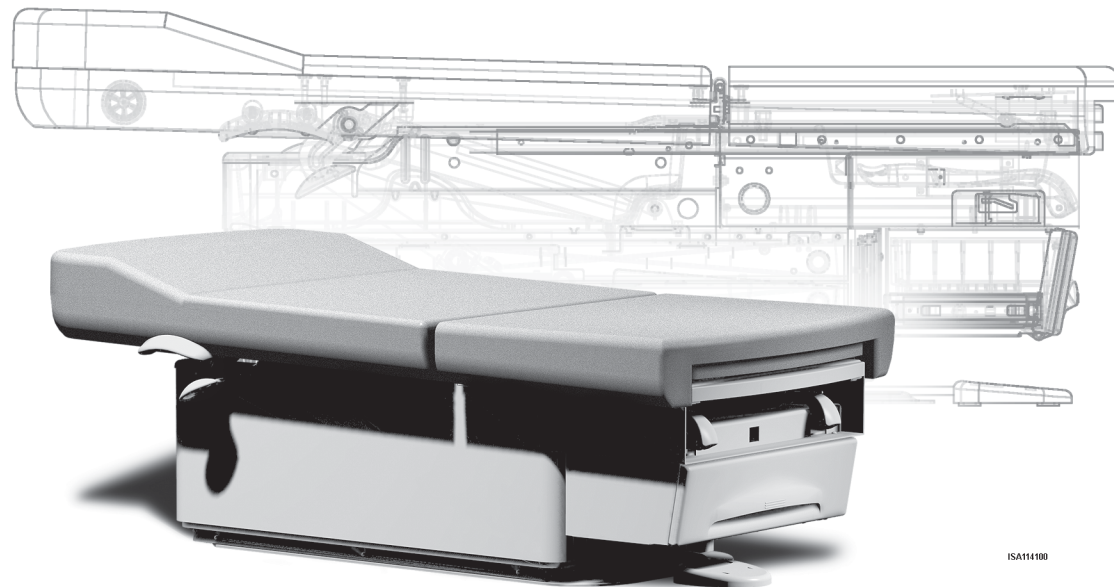

ISA11400

FOR USE BY MIDMARK TRAINED TECHNICIANS ONLY

Table Of Contents

General Information

GENERAL INFORMATION

Symbols	iii
Ordering Parts	iii
Serial Number Location	iii
Specifications	iv
Range of Motion	iv
Model Identification /	
Compliance Charts:	
222	v
223	vi
622 / 623	vii
Scheduled Maintenance	viii
Warranty Information	ix

Section A

OPERATION & TROUBLESHOOTING

Attention!

If table has no power, refer to Base Up / Down Function to troubleshoot (*No Up or Down*).

Base Up / Down Function	A-2
Back Up / Down Function:	
Manual (222 / 622)	A-11
Power (223 / 623)	A-14
<u>Optional Features</u>	
Drawer Heater System	A-23
Table Receptacle	A-27
Auto Return Function	A-29
Upholstery Heater System	A-32

Section B

COMPONENT TESTING & REPLACEMENT

Fuses	B-2
Limit Switches	B-4
Foot Control	B-6
Base / Back Actuator	B-11
Back Release Mechanism	B-17
Main PC Board	B-19
Drawer Heater System	B-23
Upholstery Heater System	B-29

Section C

ACCESS PROCEDURES

Table Shrouds	
Removal/Installation	C-2
Raising / Lowering	
Table Manually	C-5
Upholstery Removal/Installation:	
Ritter models	C-6*
Midmark models	C-7*
Chair Arm / Brace	
Removal	C-8
Top Cover	
Removal / Installation	C-9
Back Limit Switch Access .	C-9

Section D

WIRING DIAGRAMS

222	D-1
223	D-1
622	D-1
623	D-1

Section E

EXPLODED VIEWS / PARTS LISTS

222	E-2
223	E-3
622	E-4
623	E-5

* Indicates multiple pages due to model / serial number break(s)

Symbols



Caution

Indicates a potentially hazardous situation which could result in injury if not avoided.



Equipment Alert

Indicates a potentially hazardous situation which could result in equipment damage if not avoided.

Note

Amplifies a procedure, practice, or condition.



In Section A, test the components in the order indicated. (ex. **1st** ✓ then, **2nd** ✓)

Refer to Section B for component testing procedures.

These symbols are used throughout this manual to represent the operational status of table functions and components.



Indicates the function / component is working properly. No action required.



Indicates the function / component is working, but a problem exists.



Indicates the function / component is not working at all.

Ordering Parts

The following information is required when ordering parts:

- Serial number & model number
- Part number for desired part.

[Refer to Exploded Views / Parts Lists section]

Non-warranty part orders may be faxed to Midmark using the Fax Order Form in the back of this manual.

For warranty part orders, call Midmark's Technical Service Department with the required information.

Hours: 8:00 am until 5:00 pm EST [Monday - Friday]

Phone: 1-(800)-Midmark

Serial Number Location

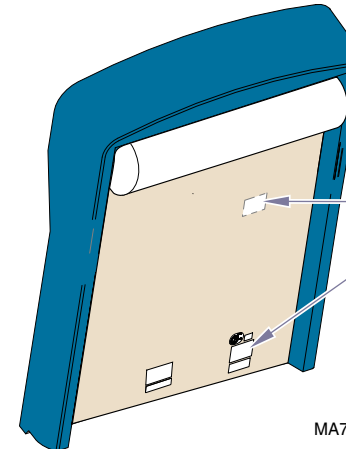

**Serial / Model
Number Label**
(exact location may vary)

MA731100i

General Information

Specifications

Patient Weight (maximum)	400 lbs (181.4 kgs)
Paper Roll (maximum size):	21 in. long x 3.5 in. diameter (53.3 x 8.9 cm)
Export models	19.7 in. long x 4.7 in. diameter (50 cm x 12 cm)
Range of Motion	See illustration on this page
Dimensions	See illustration on next page
Weight of Table:	
[230 VAC models <u>only</u> : 230 V transformer adds 14.5 lbs (6.5 kg)]	
w/ upholstery	325 lbs (147.4 kg)
w/packaging & skid (no upholstery)	375 lbs (192.7 kg)
Weight of Upholstery:	
w/packaging (shipped separately)	40 lbs (18.1 kg)
Power Cord(s) [115V models have two cords]:	8 ft. (243.8 cm) long
Electrical Rating:	See Compliance Charts
Foot Control Voltage:	14 VAC, SELV (Safety Extra Low Voltage)
Duplex Receptacle	
maximum load:	115 VAC, 5A
Fuses:	Refer to: Section E - Fuses
Duty Cycle:	
Actuator motor run time:	Intermittent Operation (Domestic: 30 seconds ON / 5 minutes OFF) (Export: 25 seconds ON / 7 minutes OFF)
Receptacle / Drawer Heater / Uph. Htr:	Continuous Operation
Classifications:	Class I, Type B Applied Part, Ordinary Equipment, Intermittent Operation (Domestic: 30 seconds ON / 5 minutes OFF) (Export: 25 seconds ON / 7 minutes OFF)
Protection against ingress of fluids:	IPX0 [Foot Control <u>only</u> : IPX1]
Regulatory Compliance:	See Regulatory Compliance Charts
Table Speeds (by function):	
Base	14 - 26 seconds
Back (models w/power back)	15 - 20 seconds

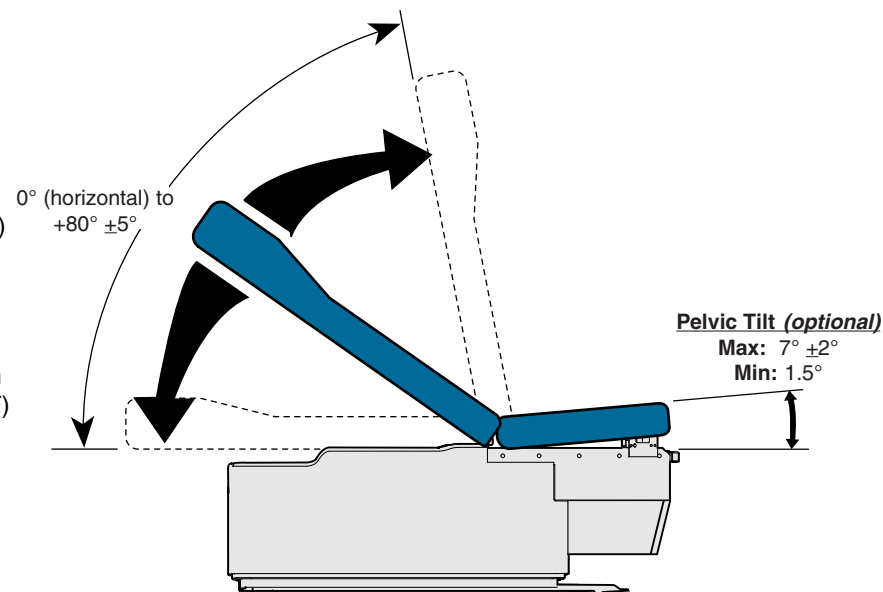
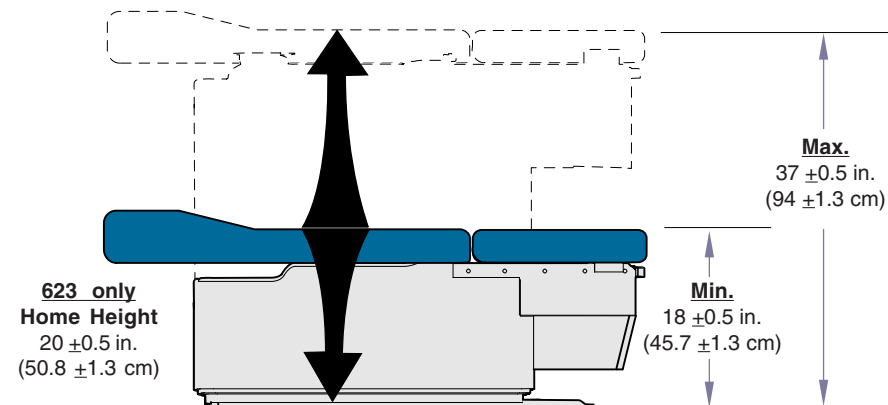

MA5998011

Model Identification / Compliance Chart - 222

Model	Description	Serial Number Prefix	Complies To:						Electrical Ratings:		
			UL 60601-1	CAN/CSA 22.2, #601.1-M90	UL 544	EN 60601-1	EN 60601-1-2 (EMC)	CE	VAC +/- 10%	Amps	Cycles (Hz)
222-001	Ritter BasicTable (Standard Top)	RG,V	X	X		X	X	X	115	5.5	50/60
222-002	Ritter BasicTable w/ Receptacle (Standard Top)	RH,V			X		X	X	115	10.5	50/60
222-003	Ritter BasicTable w/ Drawer Heater, Pelvic Tilt (Standard Top)	RJ,V	X	X		X	X	X	115	6	50/60
222-004	Ritter BasicTable w/ Receptacle, Pelvic Tilt Drawer Heater, (Standard Top)	RK,V			X		X	X	115	11	50/60
222-005	Ritter BasicTable (Seamless Top)	RG,V	X	X		X	X	X	115	5.5	50/60
222-006	Ritter BasicTable w/ Receptacle, (Seamless Top)	RH,V			X		X	X	115	10.5	50/60
222-007	Ritter BasicTable w/ Drawer Heater, Pelvic Tilt (Seamless Top)	RJ,V	X	X		X	X	X	115	6	50/60
222-008	Ritter BasicTable w/ Receptacle, Pelvic Tilt Drawer Heater, (Seamless Top)	RK,V			X		X	X	115	11	50/60
222-009	Ritter Basic Export Table w/Pelvic Tilt (Seamless Top)	RL,V				X	X	X	230	2.75	50/60
222-010	Ritter BasicExport Table w/ Pelvic Tilt, Drawer Heater (SeamlessTop)	RM,V				X	X	X	230	3	50/60
222-011	Ritter Basic Table (Canada) w/Receptacle (Standard Top)	V		X			X	X	115	10.5	50/60
222-012	Ritter Basic Table (Canada) w/Receptacle, Pelvic Tilt, Drawer Heater (Standard Top)	V		X			X	X	115	11	50/60
222-013	Ritter Basic Table (Canada) w/Receptacle (SeamlessTop)	V		X			X	X	115	10.5	50/60
222-014	Ritter BasicTable (Canada) w/Receptacle, Pelvic Tilt, Drawer Heater (Seamless Top)	V		X			X	X	115	11	50/60
222-015	Ritter BasicTable w/ Receptacle	V	X	X		X	X	X	115	10.5	50/60
222-016	Ritter BasicTable w/ Receptacle, Pelvic Tilt, Drawer Heater	V	X	X		X	X	X	115	11	50/60
222-017	Ritter BasicTable - Export w/ Pelvic Tilt	V	X	X		X	X	X	230	2.75	50/60

Fire Code Ratings:

All upholstery complies with California Bureau of Home Furnishing [Technical Bulletin 117](#).

Optional upholstery is available that complies with California Bureau of Home Furnishing [Technical Bulletin 133](#).

General Information

Model Identification / Compliance Chart - 223

Model	Description	Serial Number Prefix	Complies To:						Electrical Ratings:		
			UL 60601-1	CAN/CSA 22.2, #601.1-M90	UL 544	EN 60601-1	EN 60601-1-2 (EMC)	CE	VAC +/- 10%	Amps	Cycles (Hz)
223-001	Ritter Power Back Table (Standard Top)	SC, V	X	X		X	X	X	115	7	50/60
223-002	Ritter Power BackTable w/ Receptacle (Standard Top)	SD, V			X		X	X	115	12	50/60
223-003	Ritter Power BackTable w/ Drawer Heater, Pelvic Tilt (Standard Top)	SE, V	X	X		X	X	X	115	7.5	50/60
223-004	Ritter Power BackTable w/ Receptacle, Pelvic Tilt Drawer Heater, (Standard Top)	SF, V			X		X	X	115	12.5	50/60
223-005	Ritter Power Back Table (Seamless Top)	SC, V	X	X		X	X	X	115	7	50/60
223-006	Ritter Power BackTable w/ Receptacle (Seamless Top)	SD, V			X		X	X	115	12	50/60
223-007	Ritter Power BackTable w/ Drawer Heater, Pelvic Tilt (Seamless Top)	SE, V	X	X		X	X	X	115	7.5	50/60
223-008	Ritter Power BackTable w/ Receptacle, Pelvic Tilt Drawer Heater, (Seamless Top)	SF, V			X		X	X	115	12.5	50/60
223-009	Ritter Power Back Export Table w/ Pelvic Tilt (Seamless Top)	SG, V				X	X	X	230	3.75	50/60
223-010	Ritter Power Back Export Table w/ Pelvic Tilt, Drawer Heater (Seamless Top)	SH, V				X	X	X	230	4	50/60
223-011	Ritter Power BackTable (Canada) w/ Receptacle (Standard Top)	V		X			X	X	115	12	50/60
223-012	Ritter Power BackTable (Canada) w/ Receptacle, Pelvic Tilt Drawer Heater, (Standard Top)	V		X			X	X	115	12.5	50/60
223-013	Ritter Power BackTable (Canada) w/ Receptacle (Seamless Top)	V		X			X	X	115	12	50/60
223-014	Ritter Power BackTable (Canada) w/ Receptacle, Pelvic Tilt Drawer Heater, (Seamless Top)	V		X			X	X	115	12.5	50/60
223-015	Ritter Power Back Table w/ Receptacle	V	X	X		X	X	X	115	12	50/60
223-016	Ritter Power Back Table w/ Receptacle, Pelvic Tilt, Drawer Heater	V	X	X		X	X	X	115	12.5	50/60

Fire Code Ratings:

All upholstery complies with California Bureau of Home Furnishing [Technical Bulletin 117](#).

Optional upholstery is available that complies with California Bureau of Home Furnishing [Technical Bulletin 133](#).

General Information

Model Identification / Compliance Chart - 622 / 623

Model	Description	Serial Number Prefix	Complies To:						Electrical Ratings:		
			UL 60601-1	CAN/CSA 22.2, #601.1-M90	UL 544	EN 60601-1	EN 60601-1-2 (EMC)	CE	VAC +/- 10%	Amps	Cycles (Hz)
622-001	Midmark Manual Back Table w/ Receptacle	SJ, V			X		X	X	115	10.5	50/60
622-002	Midmark Manual BackTable w/ Receptacle, Drawer Heater, Pelvic Tilt, & Heated Upholstery	SK, V			X		X	X	115	11.5	50/60
622-003	Midmark Manual Back Table w/ Pelvic Tilt	SN, V	X	X		X	X	X	230	2.75	50/60
622-004	Midmark Manual Back Table w/ Drawer Heater, Pelvic Tilt, & Heated Upholstery	SP, V	X	X		X	X	X	230	3.25	50/60
622-005	Midmark Manual Back Table (Canada) w/ Receptacle	V		X			X	X	115	10.5	50/60
622-006	Midmark Manual BackTable (Canada) w/ Receptacle, Drawer Heater, Pelvic Tilt, & Heated Upholstery	V		X			X	X	115	11.5	50/60
622-007	Midmark Manual Back Table w/ Receptacle	V	X	X		X	X	X	115	10.5	50/60
622-008	Midmark Manual Back Table w/ Receptacle, Drawer Heater, Pelvic Tilt, & Heated Upholstery	V	X	X		X	X	X	115	11.5	50/60
623-001	Midmark Power BackTable w/ Receptacle	SL, V			X		X	X	115	12.5	50/60
623-002	Midmark Power BackTable w/ Receptacle, Pelvic Tilt Drawer Heater, & Heated Upholstery	SM, V			X		X	X	115	13.5	50/60
623-003	Midmark Power BackTable w/ Pelvic Tilt	SR, V	X	X			X	X	230	3.75	50/60
623-004	Midmark Power BackTable w/ Pelvic Tilt, Drawer Heater, & Heated Upholstery	SS, V	X	X			X	X	230	4.25	50/60
623-005	Midmark Power BackTable (Canada) w/ Receptacle	V		X			X	X	115	12.5	50/60
623-006	Ritter Power BackTable (Canada) w/ Receptacle, Pelvic Tilt Drawer Heater, Heated Upholstery	V		X			X	X	115	13.5	50/60
623-007	Midmark Power Back Table w/ Receptacle	V	X	X		X	X	X	115	12.5	50/60
623-008	Midmark Power Back Table w/ Receptacle, Pelvic Tilt Drawer Heater, & Heated Upholstery	V	X	X		X	X	X	115	13.5	50/60
623-009	Midmark Power Back Table - Export w/ Pelvic Tilt	V	X	X		X	X	X	230	3.75	50/60
623-010	Midmark Power Back Table - Export w/ Pelvic Tilt, Drawer Heater, & Heated Upholstery	V	X	X		X	X	X	230	4.25	50/60

Fire Code Ratings:

All upholstery complies with California Bureau of Home Furnishing [Technical Bulletin 117](#).

Optional upholstery is available that complies with California Bureau of Home Furnishing [Technical Bulletin 133](#).

General Information

Scheduled Maintenance / Barrier-Free [®] Examination Table						
Interval	Inspection or Service	Service, Adjust , Repair and / or Replace as Required (Refer to appropriate S&P or Quick Reference Guide)	222	223	622	623
Weekly	Cleaning	Clean upholstery with diluted bleach solution. 10:1 (water:bleach)	X	X	X	X
		Wipe painted metal & plastic surfaces with a clean soft cloth and mild cleaner. (NOTE: Periodic application of common furniture wax will ease cleaning, and maintain the luster of the surfaces).	X	X	X	X
	Obvious Damage	Visually inspect components for damage that could cause problems during operation or unsafe operation.	X	X	X	X
Semi-Annually	Mechanical Operation	Check all mechanical functions using the foot control. Repeat using the hand control when present.	X	X	X	X
		Check manual back release mechanism for proper operation.	X	X	X	X
		Table shrouds should move smoothly & quietly when base is raised & lowered. (NOTE: There are plastic glides on the shroud tabs. Missing glides may result in noisy operation.)	X	X	X	X
	Labels / Decals	Replace any missing or illegible labels.	X	X	X	X
	Lubricate	Lubricate back hinge with light machine oil.	X	X	X	X
		Lubricate footrest slide with household furniture wax.	X	X	X	X
	Hardware	All fasteners must be present and fastened securely.	X	X	X	X
	Electrical System	Inspect power cord and all wiring for damage.	X	X	X	X
Be sure all electrical connections are tight.		X	X	X	X	
	Stirrups	Check that stirrups extend easily, and lock securely into each lateral position.	X	X	X	X
Date of Service: ____ / ____ / ____			Model:			
Location: Service Technician:			Serial Number:			

Warranty Information

SCOPE OF WARRANTY

Midmark Corporation ("Midmark") warrants to the original purchaser its new Alternate Care products and components (except for components not warranted under "Exclusions") manufactured by Midmark to be free from defects in material and workmanship under normal use and service. Midmark's obligation under this warranty is limited to the repair or replacement, at Midmark's option, of the parts or the products the defects of which are reported to Midmark within the applicable warranty period and which, upon examination by Midmark, prove to be defective.

APPLICABLE WARRANTY PERIOD

The applicable warranty period, measured from the date of delivery to the original user, shall be one (1) year for all warranted products and components.

EXCLUSIONS

This warranty does not cover and Midmark shall not be liable for the following: (1) repairs and replacements because of misuse, abuse, negligence, alteration, accident, freight damage, or tampering; (2) products which are not installed, used, and properly cleaned as required in the Midmark "Installation" and or "Installation / Operation Manual for this applicable product. (3) products considered to be of a consumable nature; (4) accessories or parts not manufactured by Midmark; (5) charges by anyone for adjustments, repairs, replacement parts, installation, or other work performed upon or in connection with such products which is not expressly authorized in writing in advance by Midmark.

EXCLUSIVE REMEDY

Midmark's only obligation under this warranty is the repair or replacement of defective parts. Midmark shall not be liable for any direct, special, indirect, incidental, exemplary, or consequential damages or delay, including, but not limited to, damages for loss of profits or loss of use.

NO AUTHORIZATION

No person or firm is authorized to create for Midmark any other obligation or liability in connection with the products.

THIS WARRANTY IS MIDMARK'S ONLY WARRANTY AND IS IN LIEU OF ALL OTHER WARRANTIES, EXPRESS OR IMPLIED. MIDMARK MAKES NO IMPLIED WARRANTIES OF ANY KIND INCLUDING ANY WARRANTIES OF MERCHANTABILITY OR FITNESS FOR ANY PARTICULAR PURPOSE. THIS WARRANTY IS LIMITED TO THE REPAIR OR REPLACEMENT OF DEFECTIVE PARTS.

Additional Information

Failure to follow the guidelines listed below will void the warranty and/or render the table unsafe for use.

- If a malfunction is detected, do not use the table until necessary repairs are made.
- Do not attempt to disassemble table, replace components, or perform adjustments unless you are a Midmark authorized service technician.
- Do not use another manufacturer's parts to replace malfunctioning components. Use only Midmark replacement parts

Troubleshooting



<u>Table Function</u>	<u>Page</u>
Base Up / Down	A-2
Back Up / Down	A-11
Drawer Heater	A-23
Table Receptacle	A-27
Auto Return	A-29
Upholstery Heater System	A-32

Troubleshooting

Base UP / DOWN Function

This illustration shows only the components that affect the Base UP / DOWN function. Refer to the following page for a detailed description of current flow during this function.

NOTE: 230 VAC models only
Line voltage (230 VAC) is supplied thru two fuses (located by the power cord inlet) to a transformer that reduces the line voltage to 115 VAC before it reaches the PC Board.

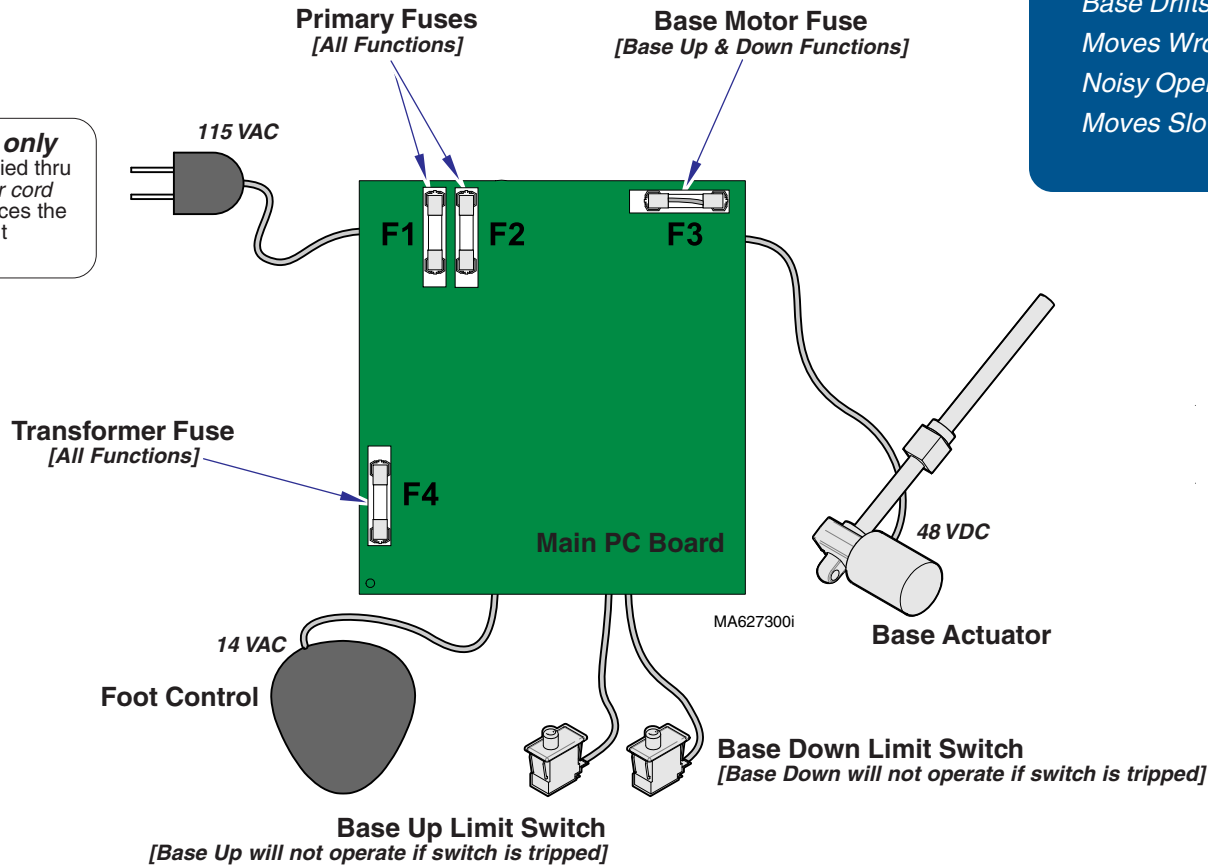

Troubleshooting

[Base Up / Down Function]

Problem	Page
No UP or DOWN Functions	A-4
No UP Function (DOWN - OK)	A-5
No DOWN Function (UP - OK)	A-6
Base Drifts Down	A-7
Moves Wrong Direction	A-8
Noisy Operation	A-9
Moves Slowly	A-10

Base UP / DOWN Function

NOTE

On 230 VAC models, line voltage (230 VAC) is supplied thru two fuses (located by IEC inlet) to a transformer that reduces the line voltage to 115 VAC before it gets to the PC board.

Power To Foot Control

115 VAC is supplied thru the two primary fuses (F1 & F2) to the transformer on the PC board. [F4 fuse protects the transformer].

The transformer reduces the line voltage and supplies 14 VAC to the foot control.

Base Up Operation

NOTE

If the Base Up limit switch is tripped (open), the Base Up function will not operate.

When the Base Up function is activated, current (14 VAC) flows thru the Up function foot switch (N.O), then back to the PC board. Circuitry on the PC Board energizes the base relay. [F3 fuse protects the base motor].

NOTE

The Base Up/Down relay has four contacts:
(2) Normally Open: Base Up function
(2) Normally Closed: Base Down function

When the base relay is energized, the (2) Normally Open contacts of the relay close. When these contacts close, current (48 VDC) flows to the actuator motor.

When current flows to the actuator thru the Normally Open contacts of the relay, the actuator motor runs and raises the table.

Actuator Motor runs until:

1. Foot control pedal is released.
2. Base Up limit switch is tripped.
3. 26 second software time limit is reached.
4. Fuse(s) opens (blows).

[Primary, Base Motor, Transformer fuse]

Base Down Operation

NOTE

If the Base Down limit switch is tripped (open), the Base Down function will not operate.

When the Base Down function is activated, current (14 VAC) flows thru the Down function foot switch (N.O.), then back to the PC Board.

NOTE

The Base Up/Down relay has four contacts:
(2) Normally Open: Base Up function
(2) Normally Closed: Base Down function

When this voltage is applied, current (48 VDC) flows to the actuator motor thru the (2) Normally Closed contacts of the Base Up/Down relay. [The relay does not energize].

When voltage flows to the actuator thru the Normally Closed contacts of the relay, the actuator motor runs and lowers the table.

Actuator Motor runs until:

1. Foot control pedal is released.
2. Base Down limit switch is tripped.
3. 26 second software time limit is reached.
4. Fuse(s) opens (blows).

[Primary, Base Motor, Transformer fuse]



Equipment Alert



If an overload condition* is detected the PC board will "beep" and all power functions will be disabled. Release the function button, remove load, then retry function.

*(weight limit exceeded, mechanical binding, etc),

Troubleshooting



Refer To: Page

- Fuses B-2
- Limit Switches B-4
- Foot Control B-6
- Base / Back Actuator B-11
- Base Relay Test B-20
- Wiring Diagrams D-1
- Exploded Views / Part Numbers E-1

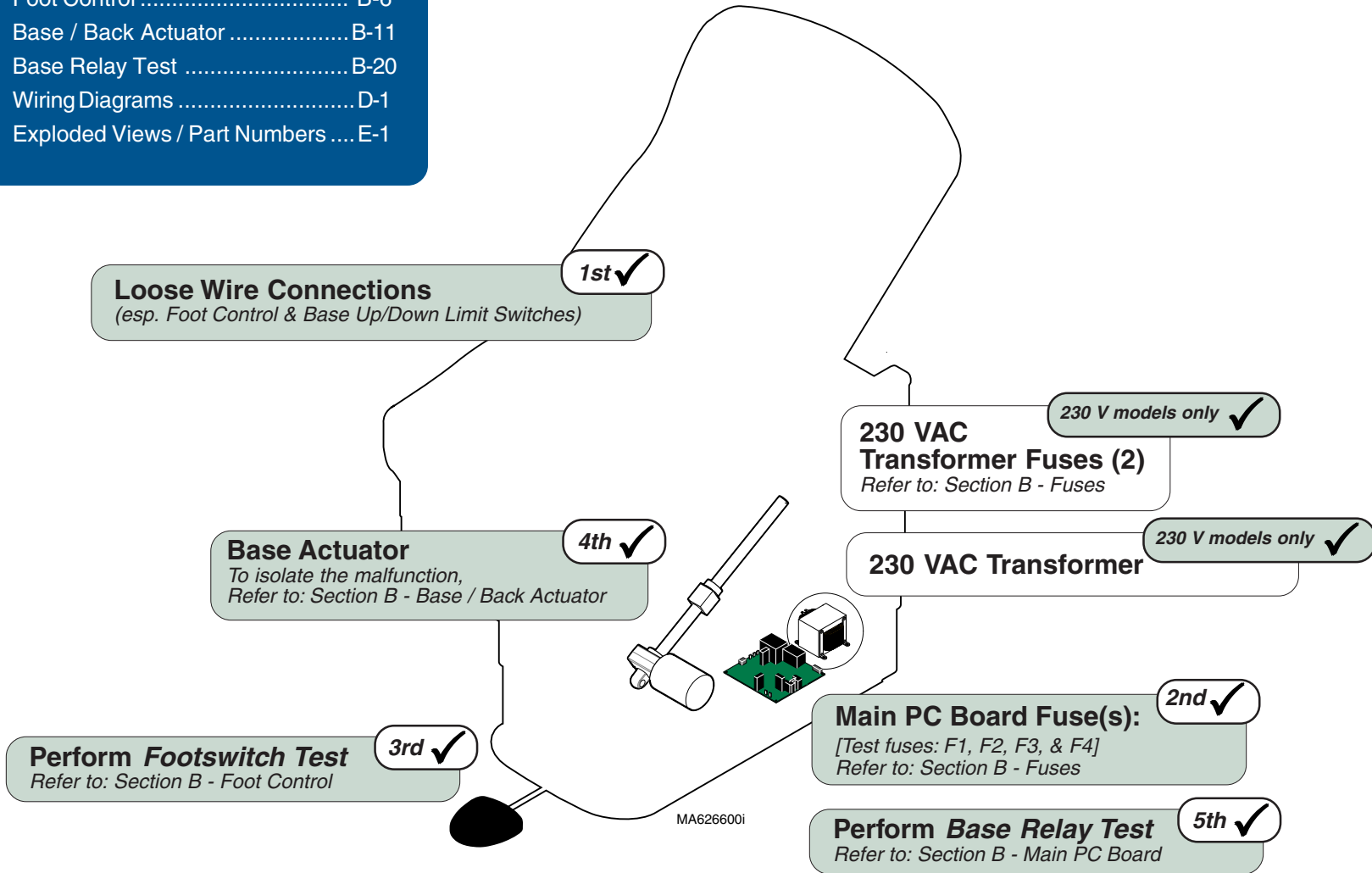
Function	Status	Problem
Base Up		No movement
Base Down		No movement



Troubleshooting

Function	Status	Problem
Base Up		No movement
Base Down		OK

Refer To:	Page
Limit Switches	B-4
Footswitch Test	B-6
Base Relay Test	B-20
Wiring Diagrams	D-1
Exploded Views / Part Numbers	E-1

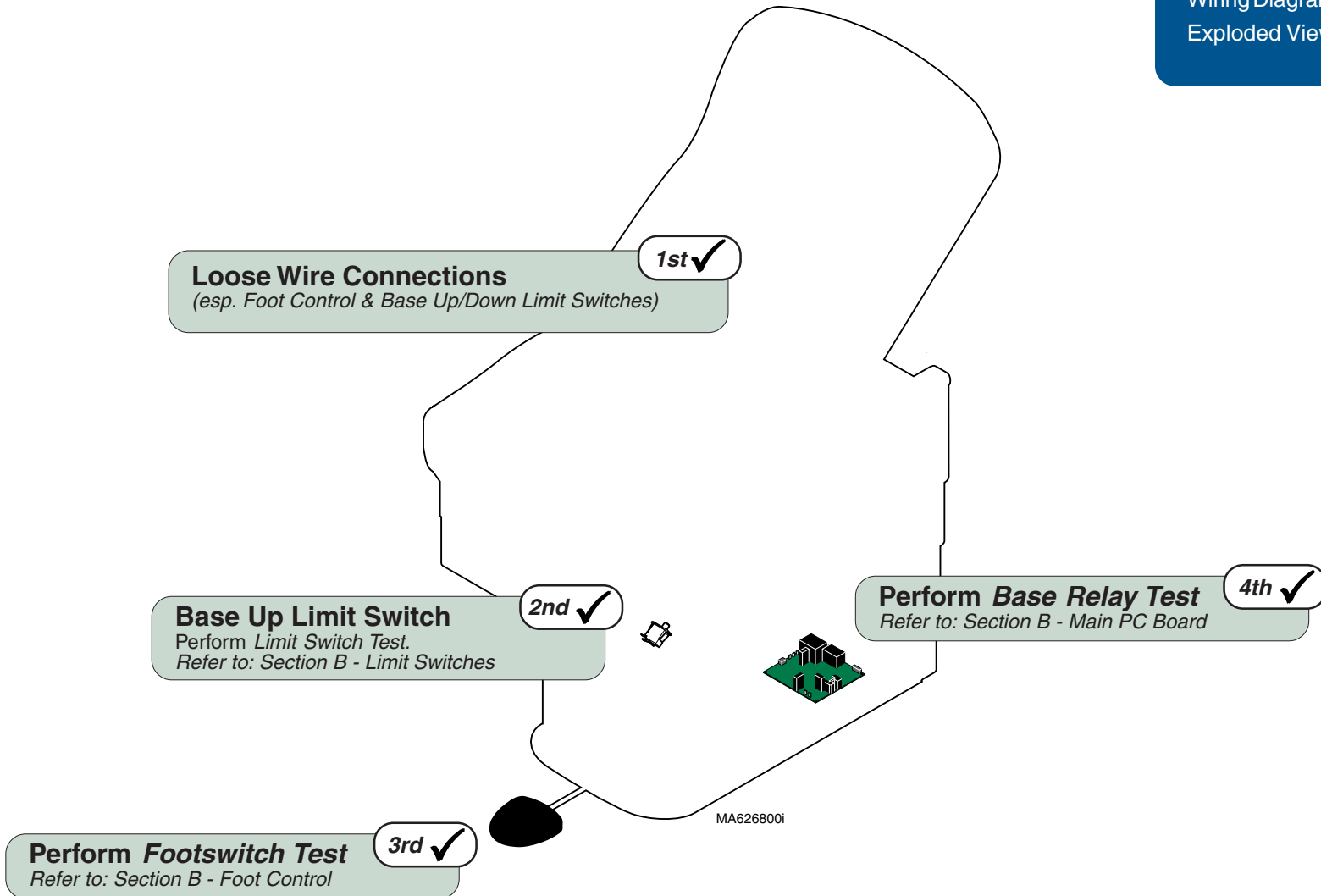



Models: All
Serial Numbers: All

Base Up / Down

Troubleshooting



Refer To: **Page**

- Limit Switches B-4
- Foot Control B-6
- Base Relay Test B-20
- Wiring Diagrams D-1
- Exploded Views / Part Numbers E-1

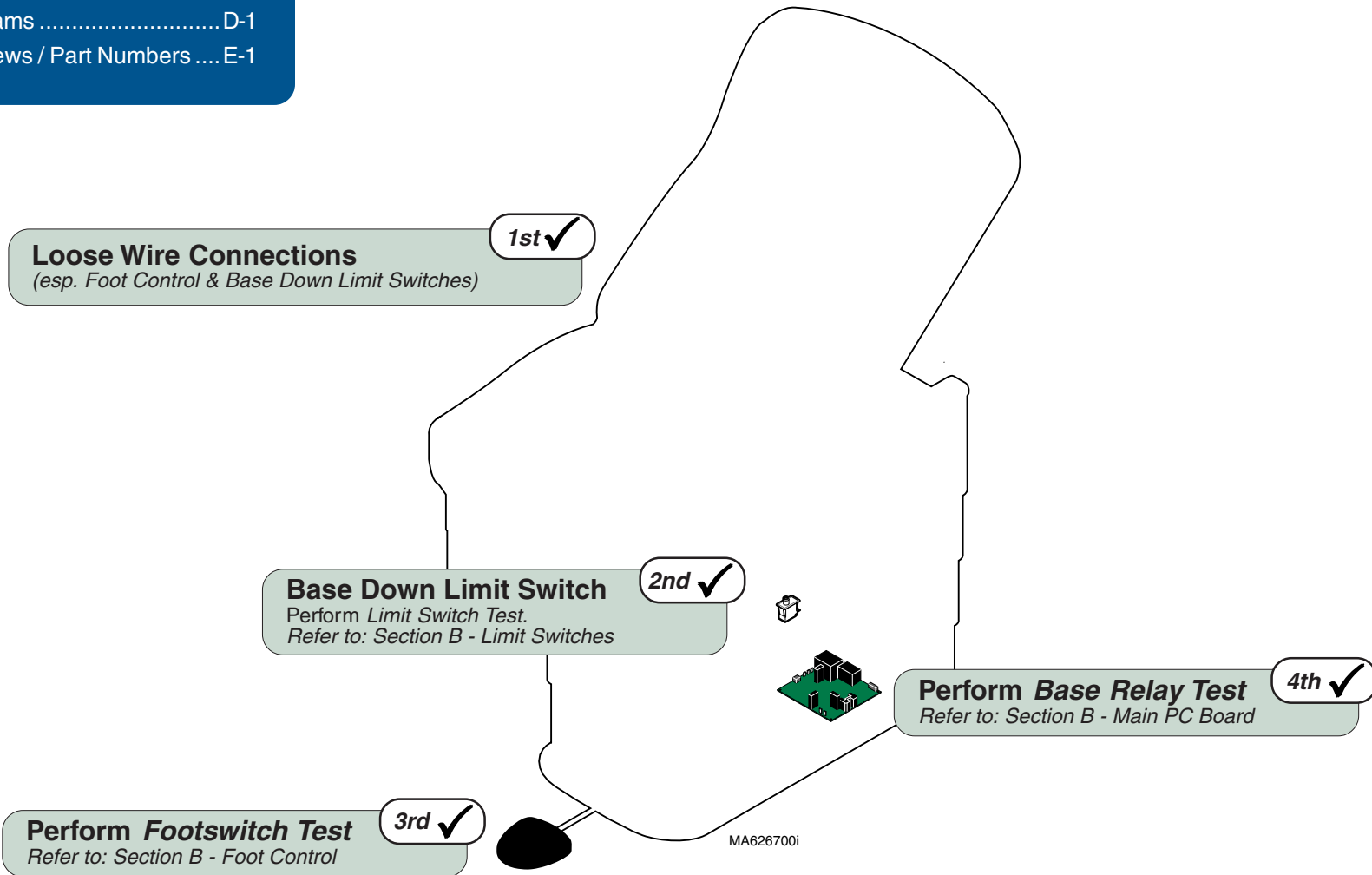
Function	Status	Problem
Base Up		OK
Base Down		No movement



Troubleshooting

Function	Status	Problem
Base Up		Table drifts down.
Base Down		Table drifts down.

Refer To:	Page
Foot Control	B-6
Base / Back Actuator	B-11
Wiring Diagrams	D-1
Exploded Views / Part Numbers	E-1

Run table up, then unplug power cord. 1st ✓
 If drifting stops, perform *Footswitch Test*.
 If drifting continues, check Base Actuator.

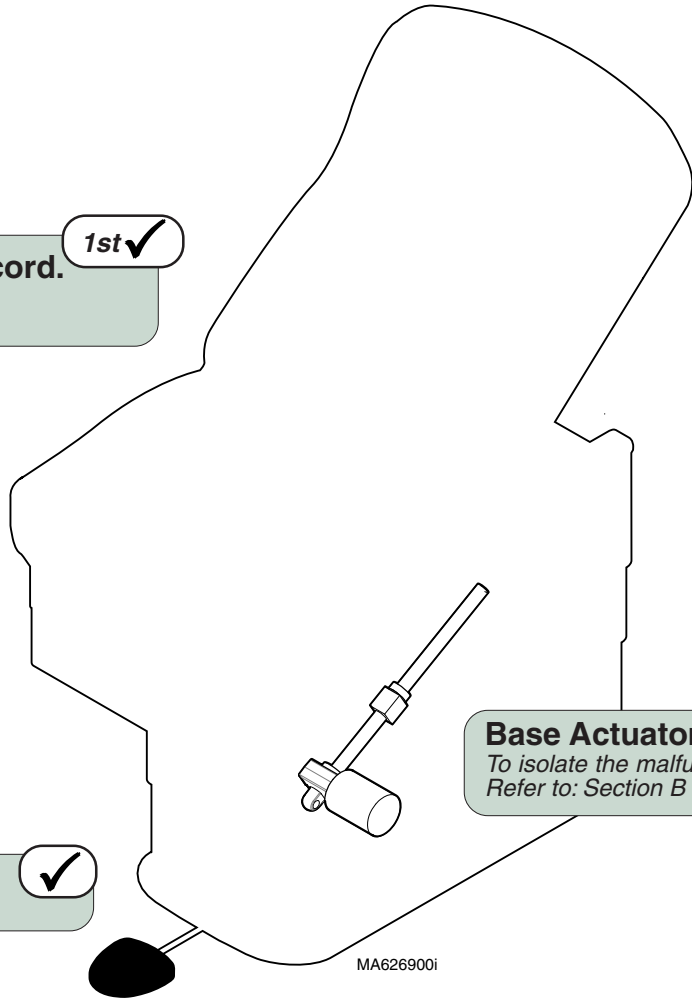

Perform Footswitch Test ✓
 Refer to: Section B - Foot Control

Base Actuator ✓
 To isolate the malfunction,
 Refer to: Section B - Base / Back Actuator

Models: All
Serial Numbers: All

Base Up / Down

Troubleshooting

Refer To: Page
 Main PC Board Replacement B-22
 Wiring Diagrams D-1
 Exploded Views / Part Numbers E-1

Function	Status	Problem
Base Up		Press Base UP pedal, table moves DOWN.
Base Down		Press Base DOWN pedal, table moves UP.

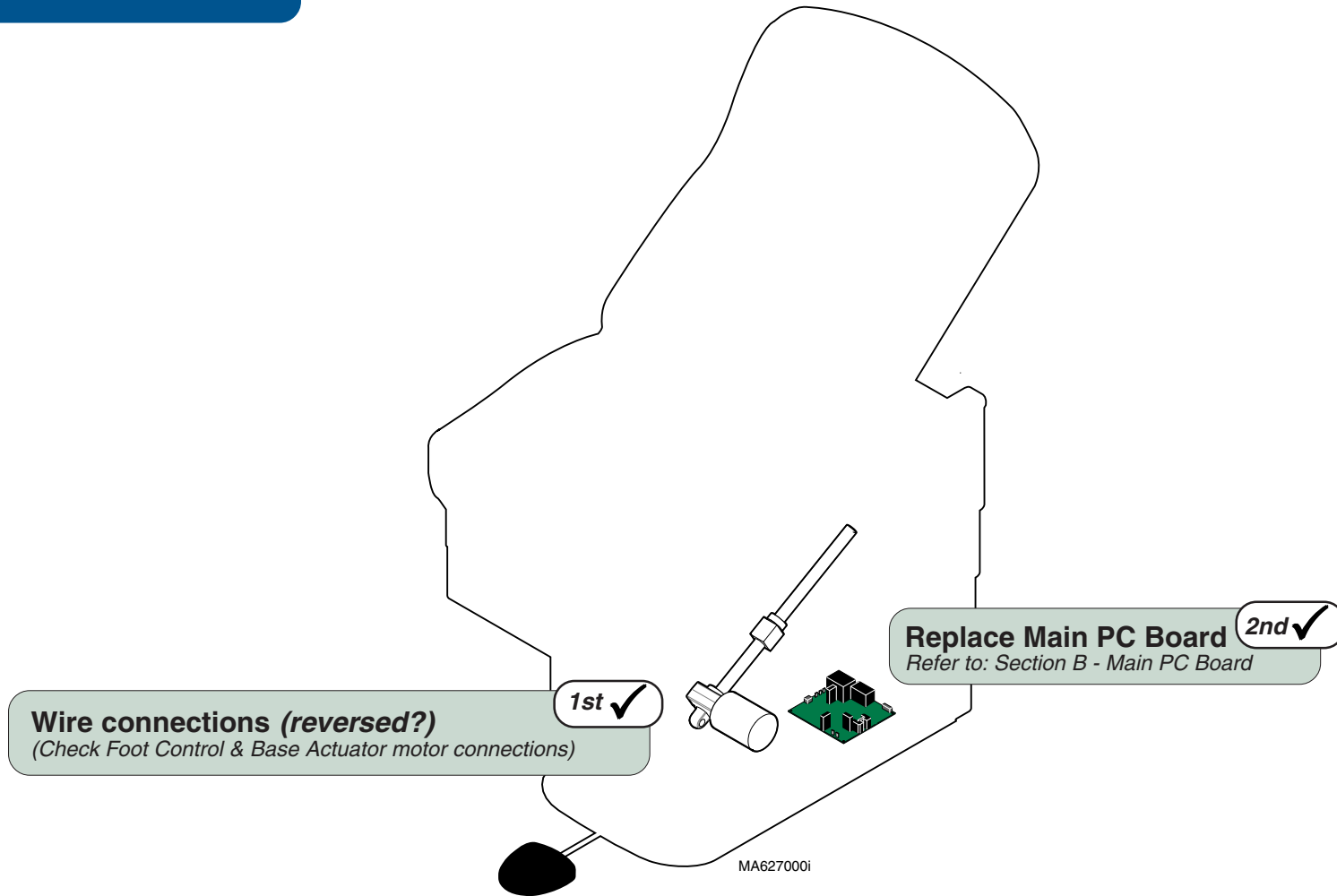

Troubleshooting

Function	Status	Problem
Base Up		Noisy / grinding / squeaking
Base Down		Noisy / grinding / squeaking

Refer To:	Page
Base Actuator Replacement	B-11
Table Shroud Removal	C-2
Wiring Diagrams	D-1
Exploded Views / Part Numbers	E-1

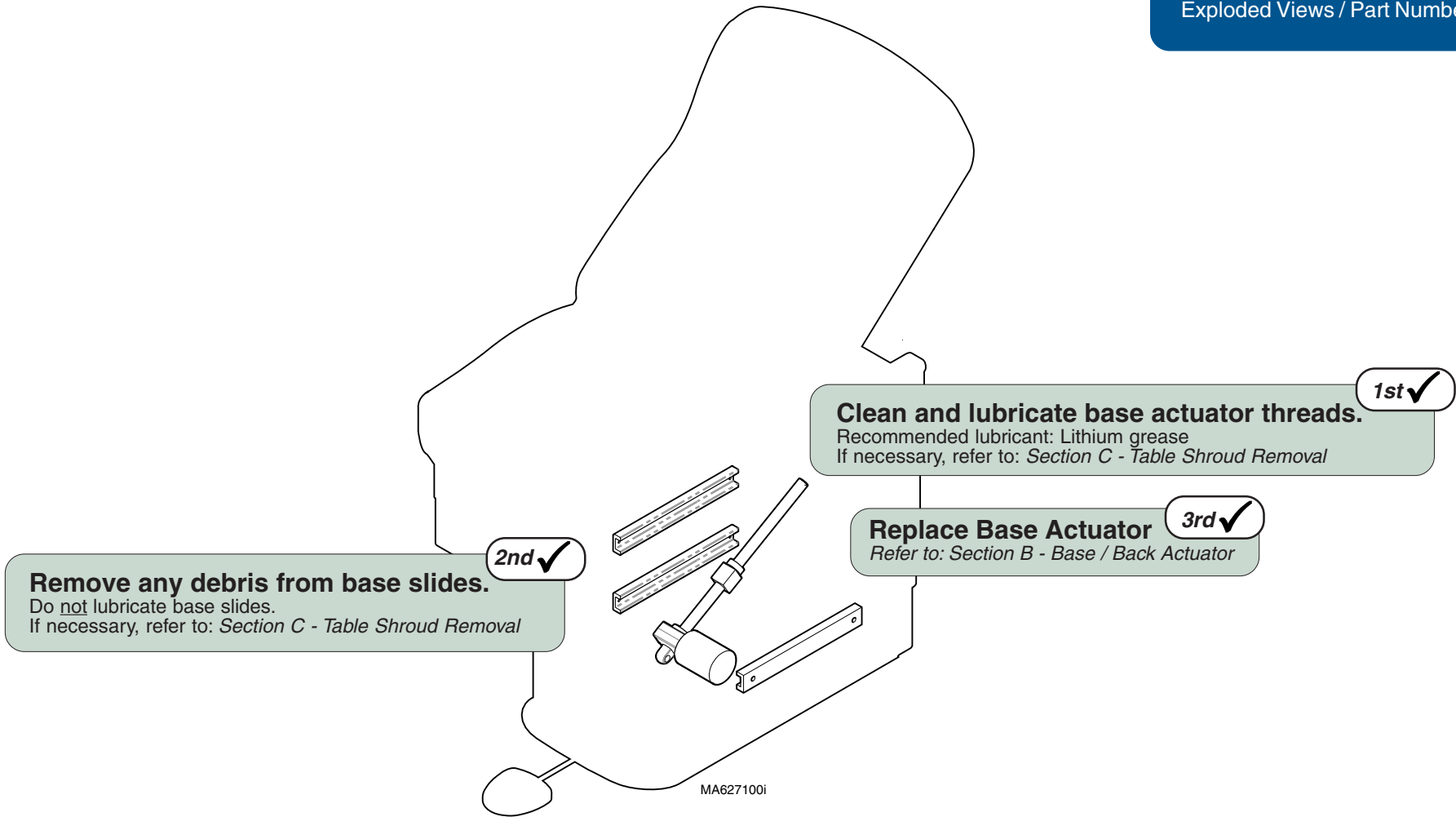

Models: All
Serial Numbers: All

Base Up / Down

Troubleshooting

Refer To: Page
 Wiring Diagrams D-1
 Exploded Views / Part Numbers .. E-1

Function	Status	Problem
Base Up		Moves slowly
Base Down		Moves slowly

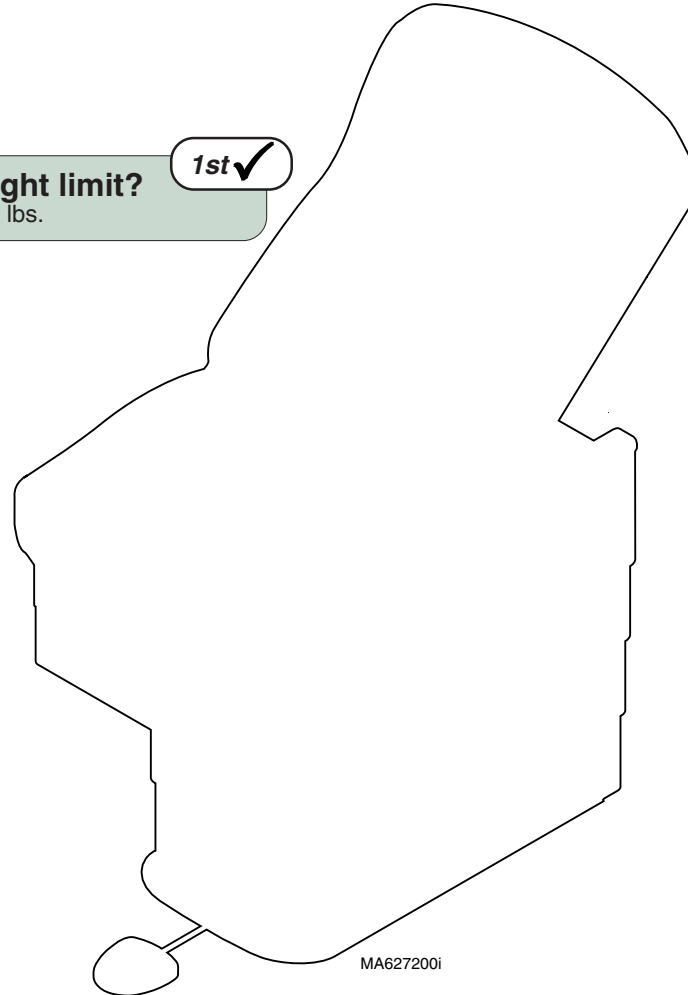

1st ✓
Did patient exceed 400 lb. weight limit?
 Inform staff that max. patient weight is 400 lbs.

2nd ✓
Low voltage to table
 Required voltage:
 115 VAC models 115 ±10% VAC
 230 VAC models 230 ±10% VAC

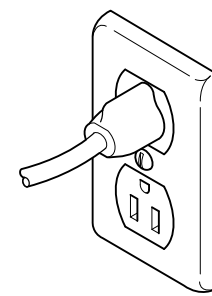

Back UP / DOWN Function (Manual)

This illustration shows only the components that affect the Back UP / DOWN function.

Back Up / Down Operation (Manual)

When either back release handle is squeezed, linkage causes the cam to rotate. When the cam compresses the pin on the top of the gas cylinder, the pressure inside the cylinder is released and the back section can be positioned Up or Down.

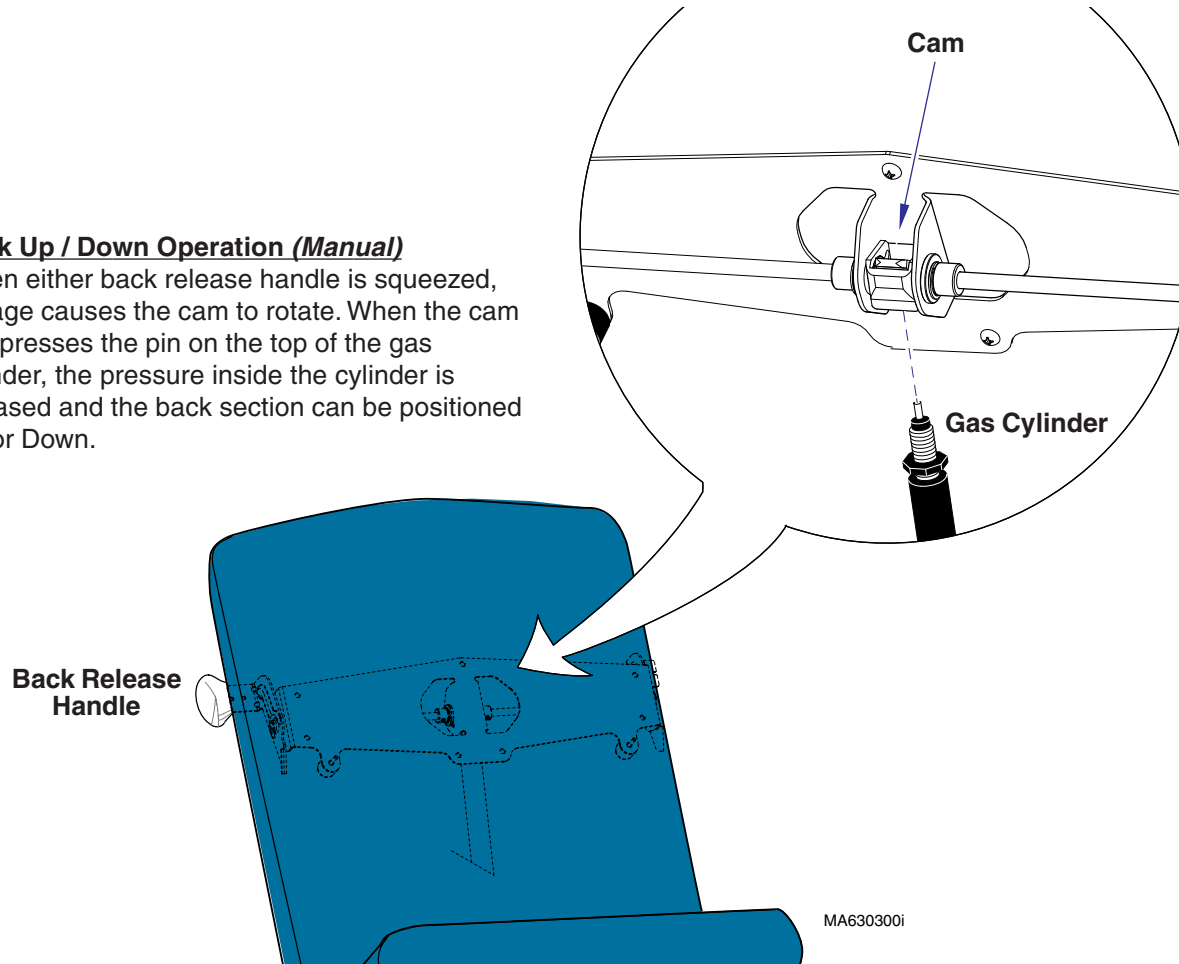

Troubleshooting

[Back Up / Down Function (Manual)]

<u>Problem</u>	<u>Page</u>
Back Drifts Up or Down	A-12
No Movement	A-13
Difficult To Position	A-13

Models:
Serial Numbers:

222 (all)
All

622 (all)
All

Back Up / Down
Manual



Troubleshooting

Function	Status	Problem
Back Up/Down		Back section drifts

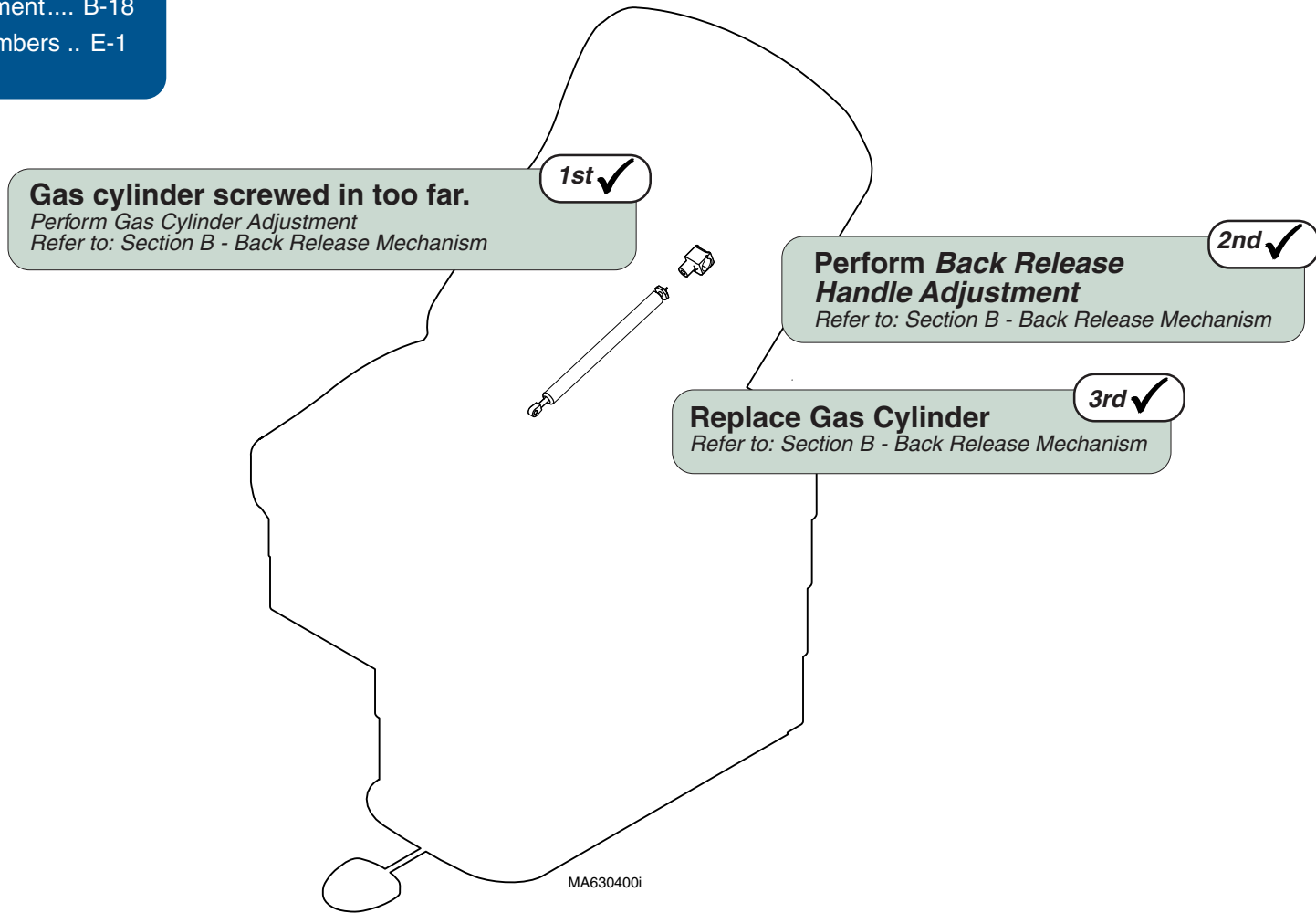
Refer To:	Page
Back Release Handle Adjustment	B-17
Gas Cylinder Replacement & Adjustment....	B-18
Exploded Views / Part Numbers ..	E-1



Troubleshooting

Function	Status	Problem
Back Up/Down		No movement
		Difficult to position

Refer To:	Page
Back Release Handle Adjustment	B-17
Gas Cylinder Replacement & Adjustment	B-18
Exploded Views / Part Numbers ..	E-1

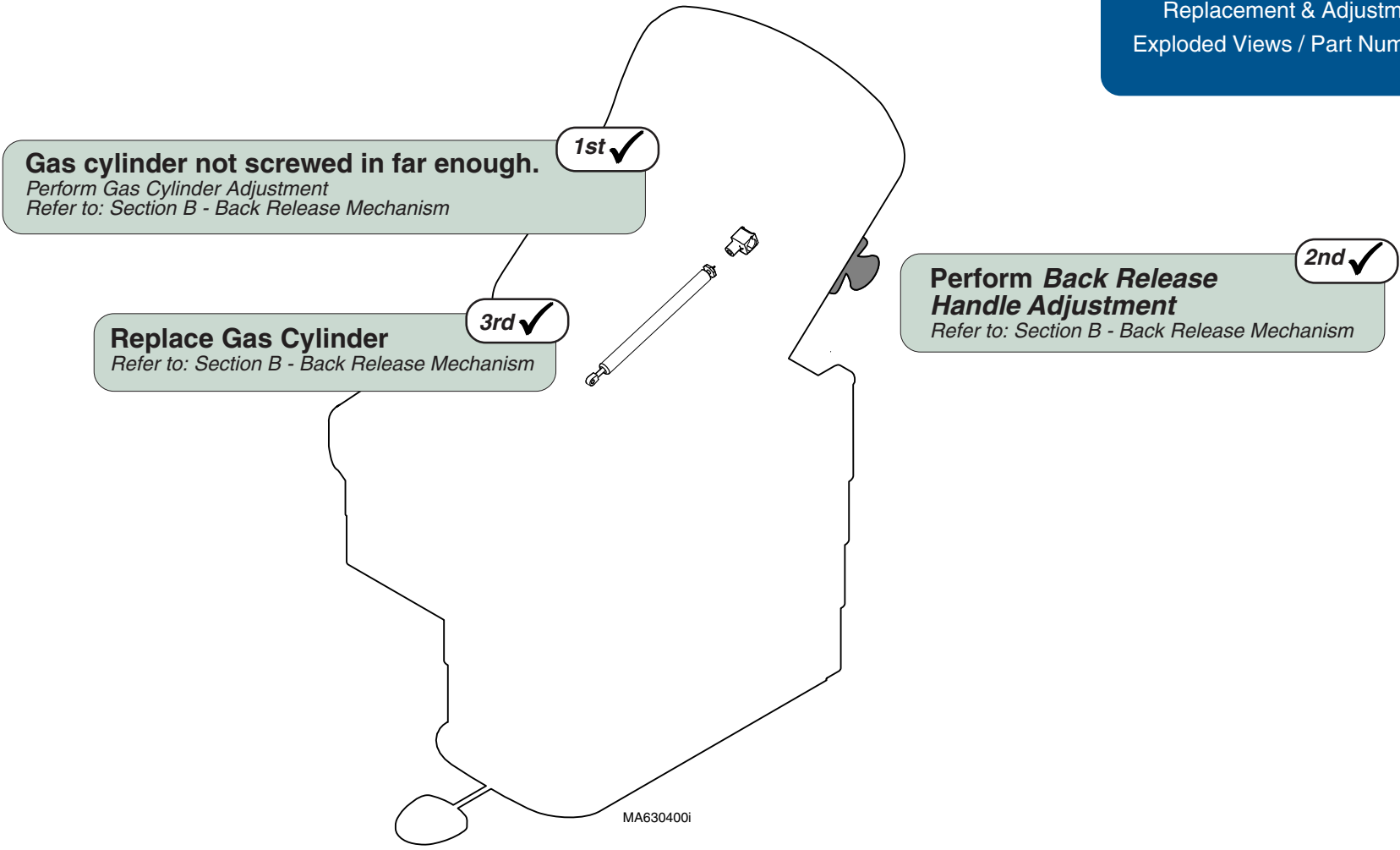

Models:	222 (all)	622 (all)
Serial Numbers:	All	All

**Back Up / Down
Manual**

Troubleshooting

Back UP / DOWN Function (Power)

This illustration shows only the components that affect the Back UP / DOWN function. Refer to the following page for a detailed description of current flow during this function.

NOTE: 230 VAC models only
Line voltage (230 VAC) is supplied thru two fuses (located by the power cord inlet) to a transformer that reduces the line voltage to 115 VAC before it reaches the PC Board.

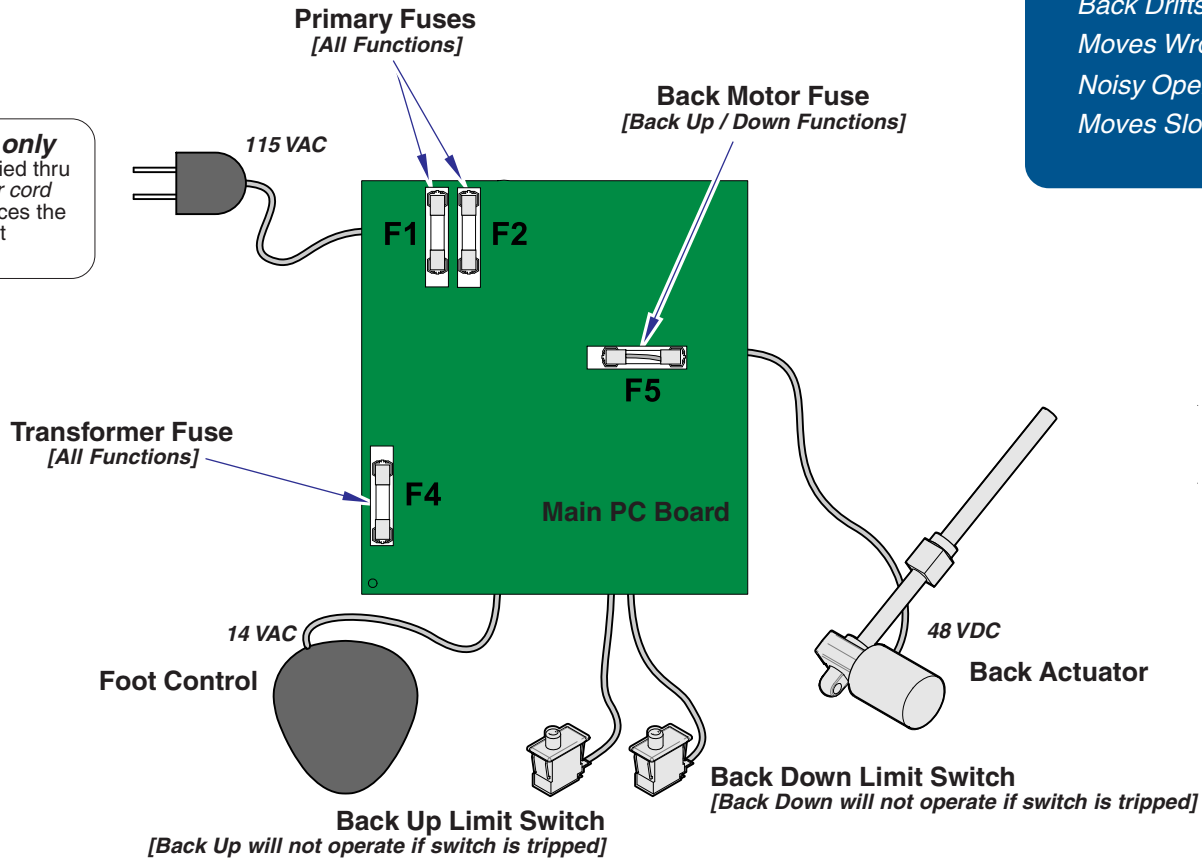

Troubleshooting

[Back Up / Down Function (Power)]

Problem	Page
No UP or DOWN Functions	A-16
No DOWN Function (UP - OK)	A-17
No UP Function (DOWN - OK)	A-18
Back Drifts Down	A-19
Moves Wrong Direction	A-20
Noisy Operation	A-21
Moves Slowly	A-22

Back UP / DOWN Function (Power)

NOTE

On 230 VAC models, line voltage (230 VAC) is supplied thru two fuses (located by IEC inlet) to a transformer that reduces the line voltage to 115 VAC before it gets to the PC board.

Power To Foot Control

115 VAC is supplied thru the two primary fuses (F1 & F2) to the transformer on the PC board. [F4 fuse protects the transformer].

The transformer reduces the line voltage and supplies 14 VAC to the foot control.

Back Up Operation

NOTE

If the Back Up limit switch is tripped (open), the Back Up function will not operate.

When the Back Up function is activated, current (14 VAC) flows thru the Up function foot switch (N.O), then back to the PC board. Circuitry on the PC Board energizes the back relay. [F5 fuse protects the back motor].

NOTE

The Back Up/Down relay has four contacts:
(2) Normally Open: Back Up function
(2) Normally Closed: Back Down function

When the back relay is energized, the (2) Normally Open contacts of the relay close. When these contacts close, current (48 VDC) flows to the actuator motor.

When current flows to the actuator thru the Normally Open contacts of the relay, the actuator motor runs and raises the back section.

Actuator Motor runs until:

1. Foot control pedal is released.
2. Back Up limit switch is tripped.
3. 26 second software time limit is reached.
4. Fuse(s) opens (blows).
[Primary, Back Motor, Transformer fuse]

Back Down Operation

NOTE

If the Back Down limit switch is tripped (open), the Back Down function will not operate.

When the Back Down function is activated, current (14 VAC) flows thru the Down function foot switch (N.O.), then back to the PC Board.

NOTE

The Back Up/Down relay has four contacts:
(2) Normally Open: Back Up function
(2) Normally Closed: Back Down function

When this voltage is applied, current (48 VDC) flows to the actuator motor thru the (2) Normally Closed contacts of the Back Up/Down relay. [The relay does not energize].

When voltage flows to the actuator thru the Normally Closed contacts of the relay, the actuator motor runs and lowers the back section.

Actuator Motor runs until:

1. Foot control pedal is released.
2. Back Down limit switch is tripped.
3. 26 second software time limit is reached.
4. Fuse(s) opens (blows).
[Primary, Back Motor, Transformer fuse]





Equipment Alert

If an overload condition* is detected the PC board will "beep" and all power functions will be disabled. Release the function button, remove load, then retry function.

*(weight limit exceeded, mechanical binding, etc),



Troubleshooting

Refer To:	Page
Fuses	B-2
Limit Switches	B-4
Foot Control	B-6
Base / Back Actuator	B-11
Back Relay Test	B-21
Wiring Diagrams	D-1
Exploded Views / Part Numbers	E-1

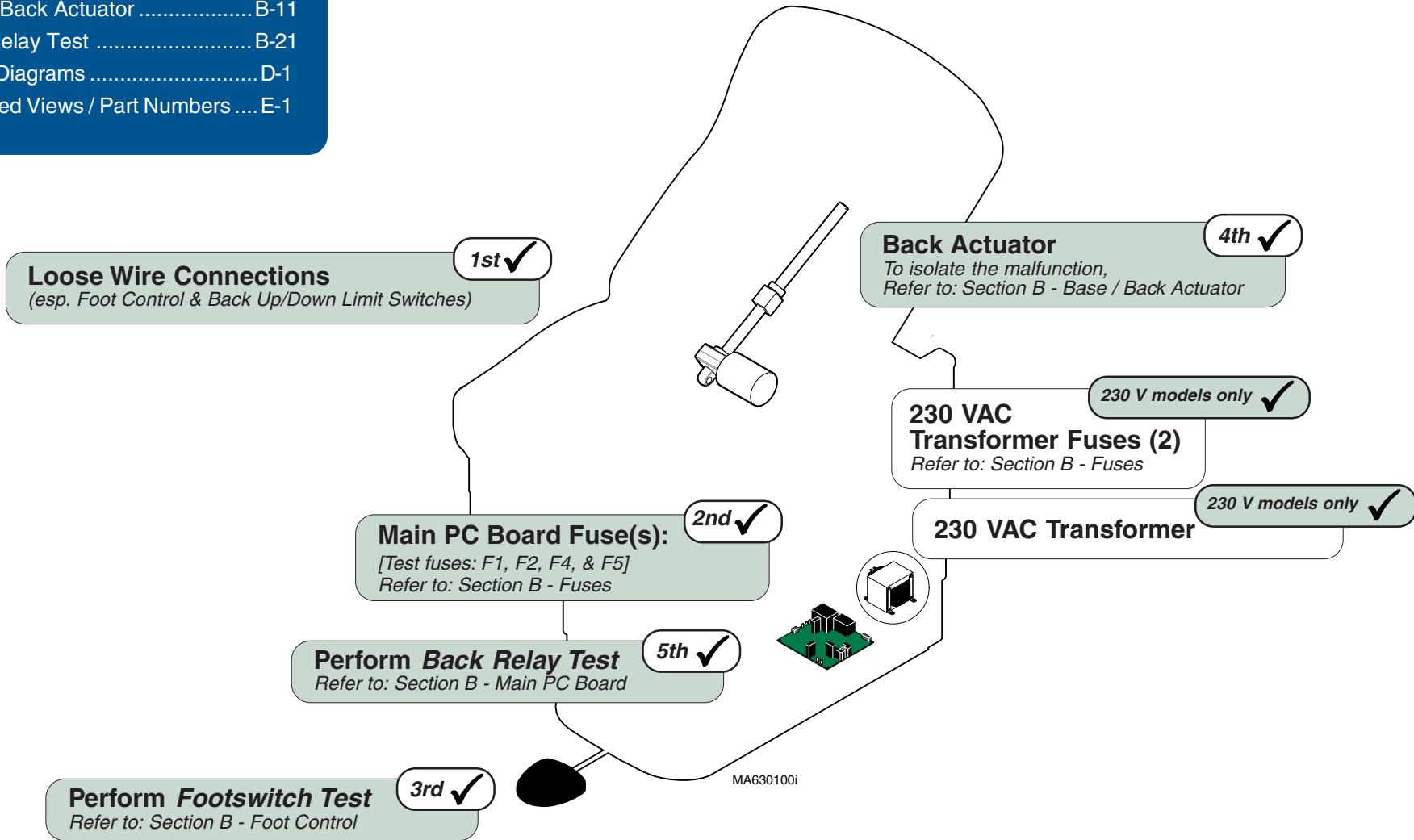
Function	Status	Problem
Back Up		No movement
Back Down		No movement



Troubleshooting

Function	Status	Problem
Back Up		OK
Back Down		No movement

Refer To:	Page
Limit Switches	B-4
Foot Control	B-6
Back Relay Test	B-18
Wiring Diagrams	D-1
Exploded Views / Part Numbers ..	E-1

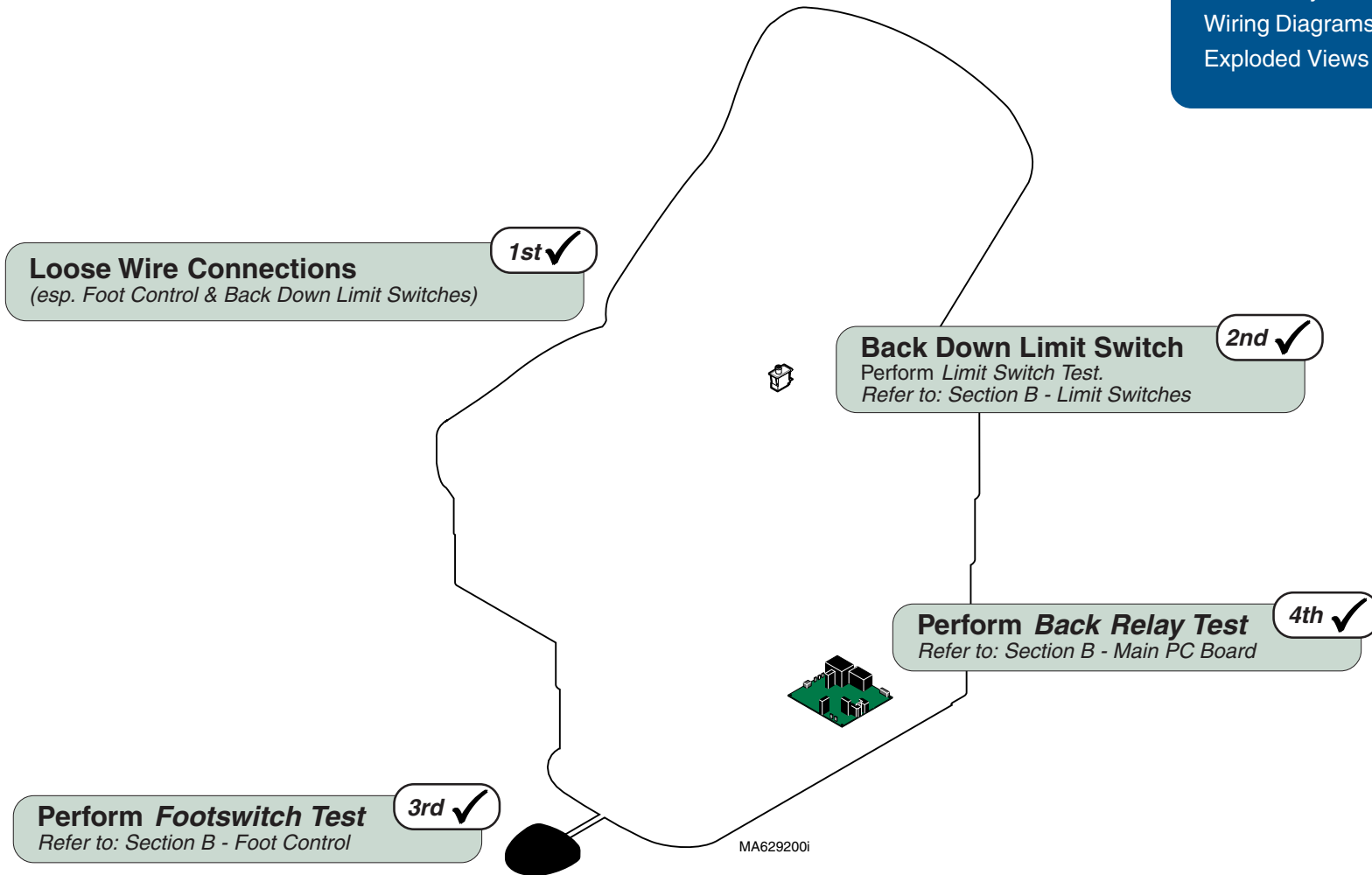



Models:	223 (all)	623 (all)
Serial Numbers:	All	All

**Back Up / Down
Power**

Troubleshooting

Refer To:	Page
Limit Switches	B-4
Foot Control	B-6
Back Relay Test	B-18
Wiring Diagrams	D-1
Exploded Views / Part Numbers ..	E-1

Function	Status	Problem
Back Up		No movement
Back Down		OK

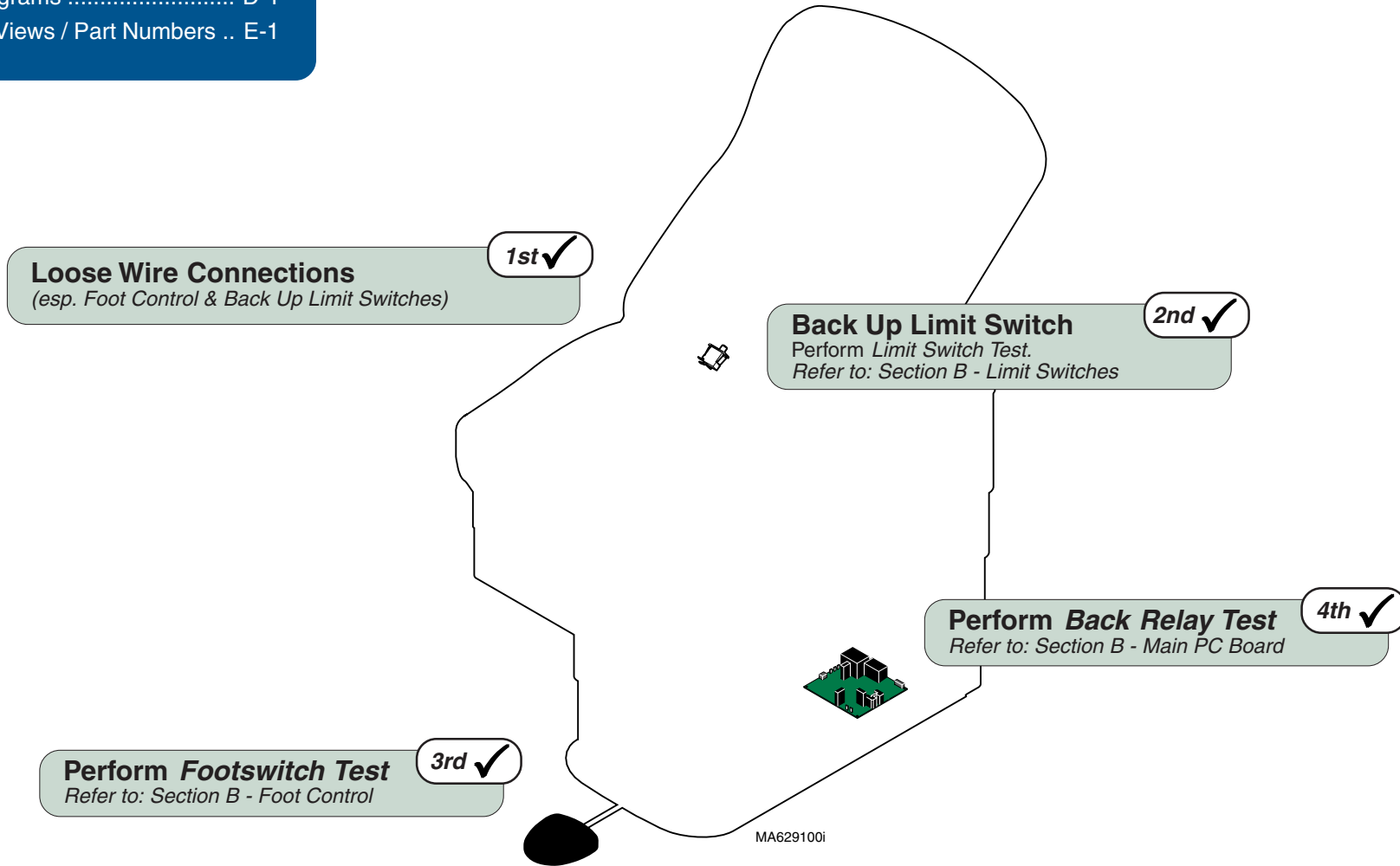

Troubleshooting

Function	Status	Problem
Back Up		Back drifts down.
Back Down		Back drifts down.

Refer To:	Page
Foot Control	B-6
Base / Back Actuator	B-11
Wiring Diagrams	D-1
Exploded Views / Part Numbers ..	E-1

Run back section up, then unplug power cord. 1st ✓
 If drifting stops, perform *Footswitch Test*.
 If drifting continues, check Back Actuator.

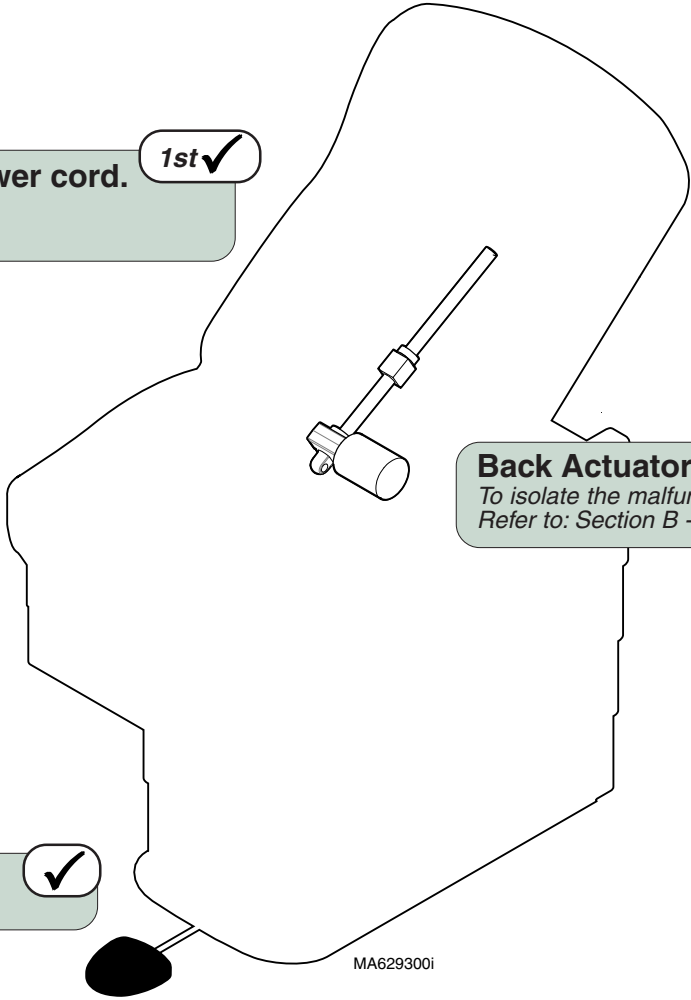

Back Actuator ✓
 To isolate the malfunction,
 Refer to: Section B - Base / Back Actuator



Perform Footswitch Test ✓
 Refer to: Section B - Foot Control

Models:	223 (all)	623 (all)
Serial Numbers:	All	All

**Back Up / Down
Power**



Troubleshooting

Refer To: **Page**
 Main PC Board Replacement B-22
 Wiring Diagrams D-1
 Exploded Views / Part Numbers E-1

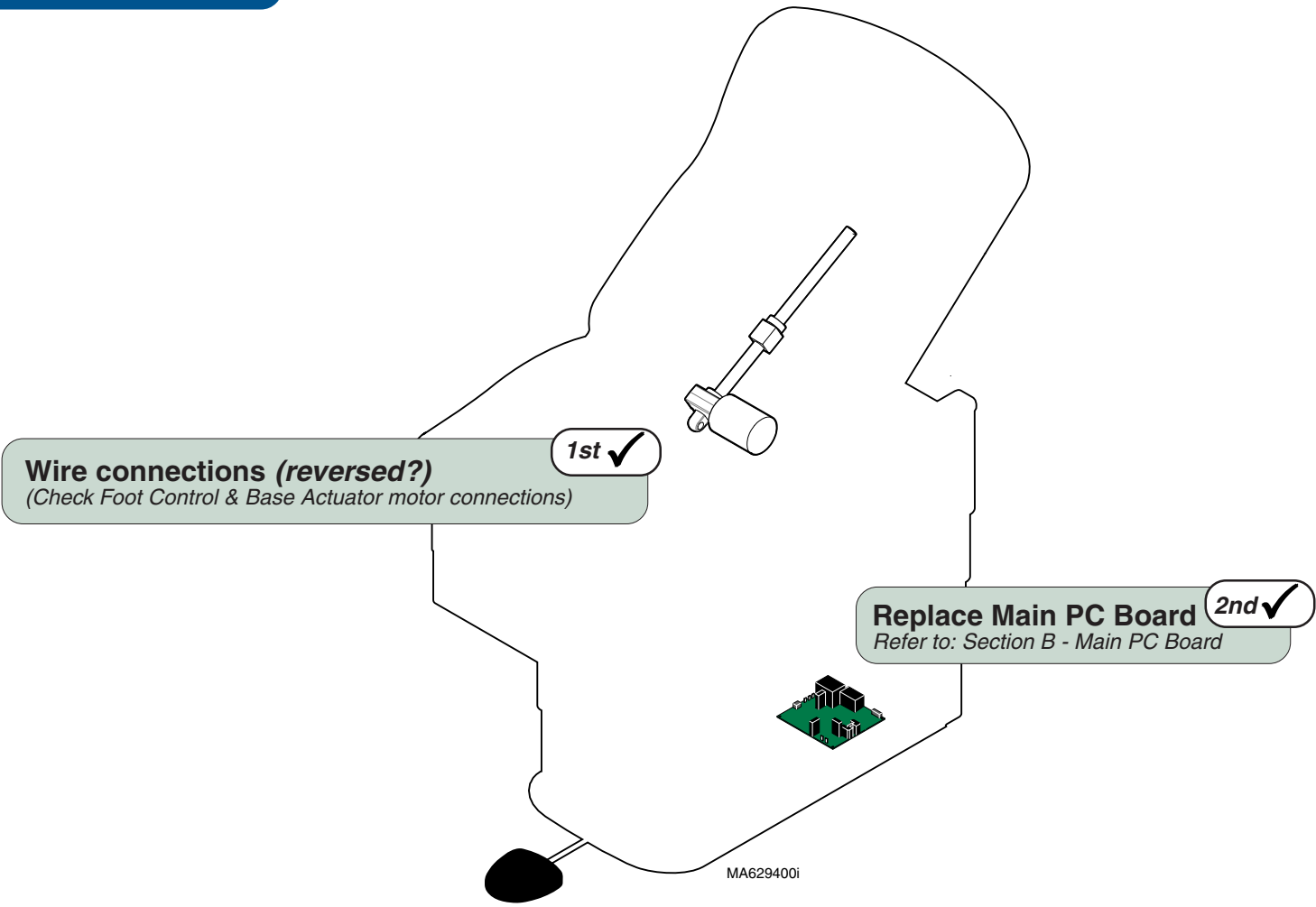
Function	Status	Problem
Back Up		Press Back UP pedal, back section moves DOWN.
Back Down		Press Back DOWN pedal, back section moves UP.



Troubleshooting

Function	Status	Problem
Back Up		Noisy / grinding / squeaking
Back Down		Noisy / grinding / squeaking

Refer To: [Page](#)
 Back Actuator Replacement B-15
 Wiring Diagrams D-1
 Exploded Views / Part Numbers .. E-1

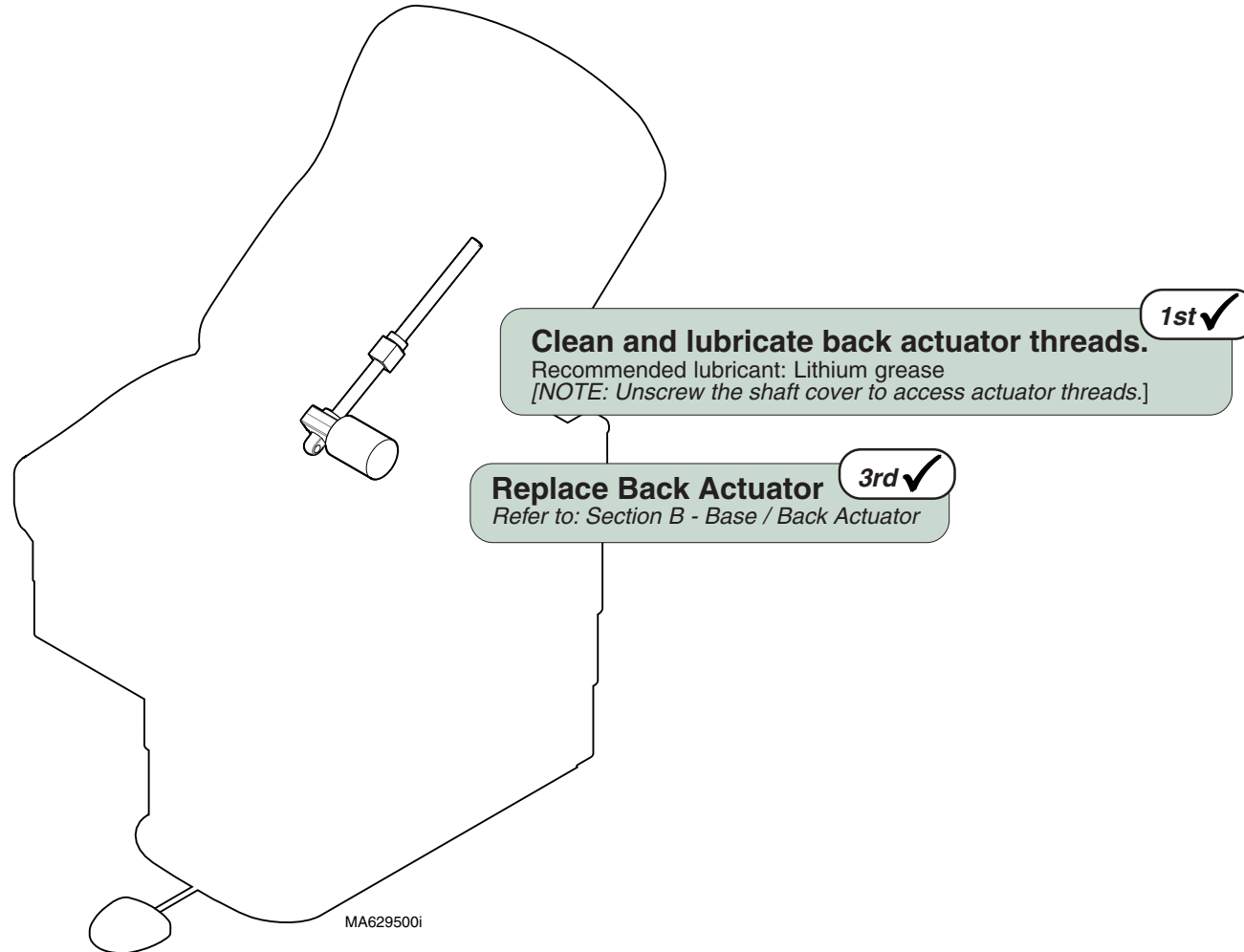



Models:	223 (all)	623 (all)
Serial Numbers:	All	All

Back Up / Down
Power

Troubleshooting

Refer To: **Page**
 Wiring Diagrams D-1
 Exploded Views / Part Numbers .. E-1

Function	Status	Problem
Back Up		Moves slowly
Back Down		Moves slowly

Did patient exceed 400 lb. weight limit? 1st ✓

Inform staff that max. patient weight is 400 lbs.

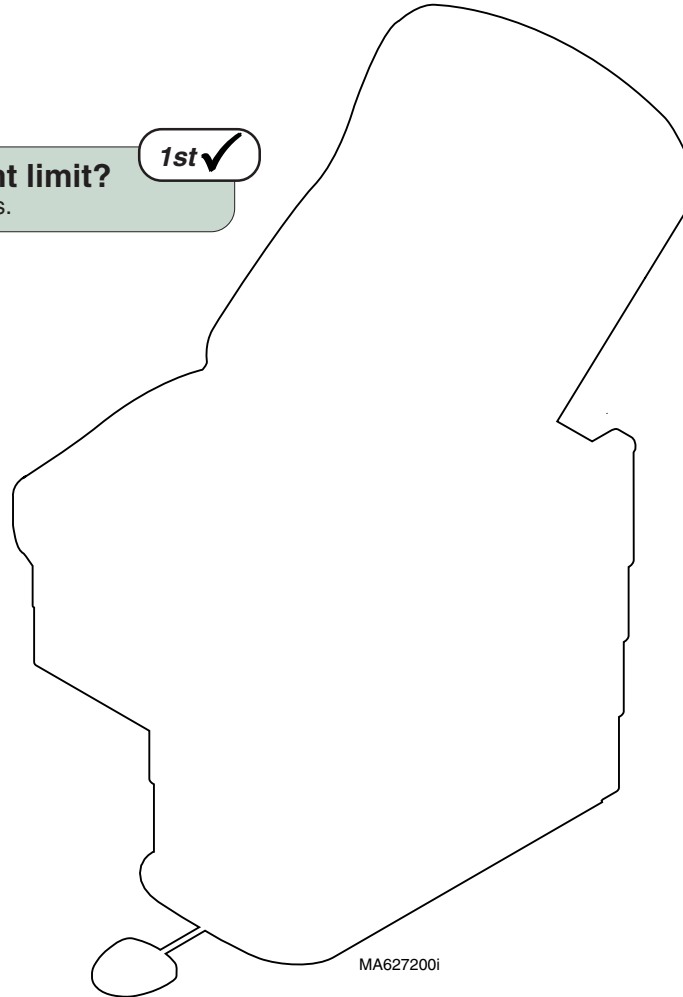

Low voltage to table 2nd ✓

Required voltage:
 115 VAC models 115 ±10% VAC
 230 VAC models 230 ±10% VAC

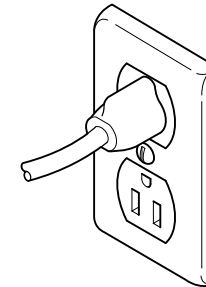

Drawer Heater System (optional)

This illustration shows only the components that affect the drawer heater system. A detailed description of current flow during this function also appears below.

Troubleshooting [Drawer Heater System]

Problem	Page
Drawer Heater Does <u>Not</u> Warm Up:	
Switch Does <u>Not</u> Illuminate	A-24
Switch Illuminates	A-25
Drawer Heater Works Properly:	
Switch Does <u>Not</u> Illuminate	A-26

Drawer Heater Operation

115 VAC is supplied directly to the Drawer Heater switch thru two fuses on the Distribution Board. [Voltage bypasses the Main PC Board].

When the drawer heater switch is turned ON, current flows to the heater plate. When the heater plate is energized, it warms the contents of the drawer.

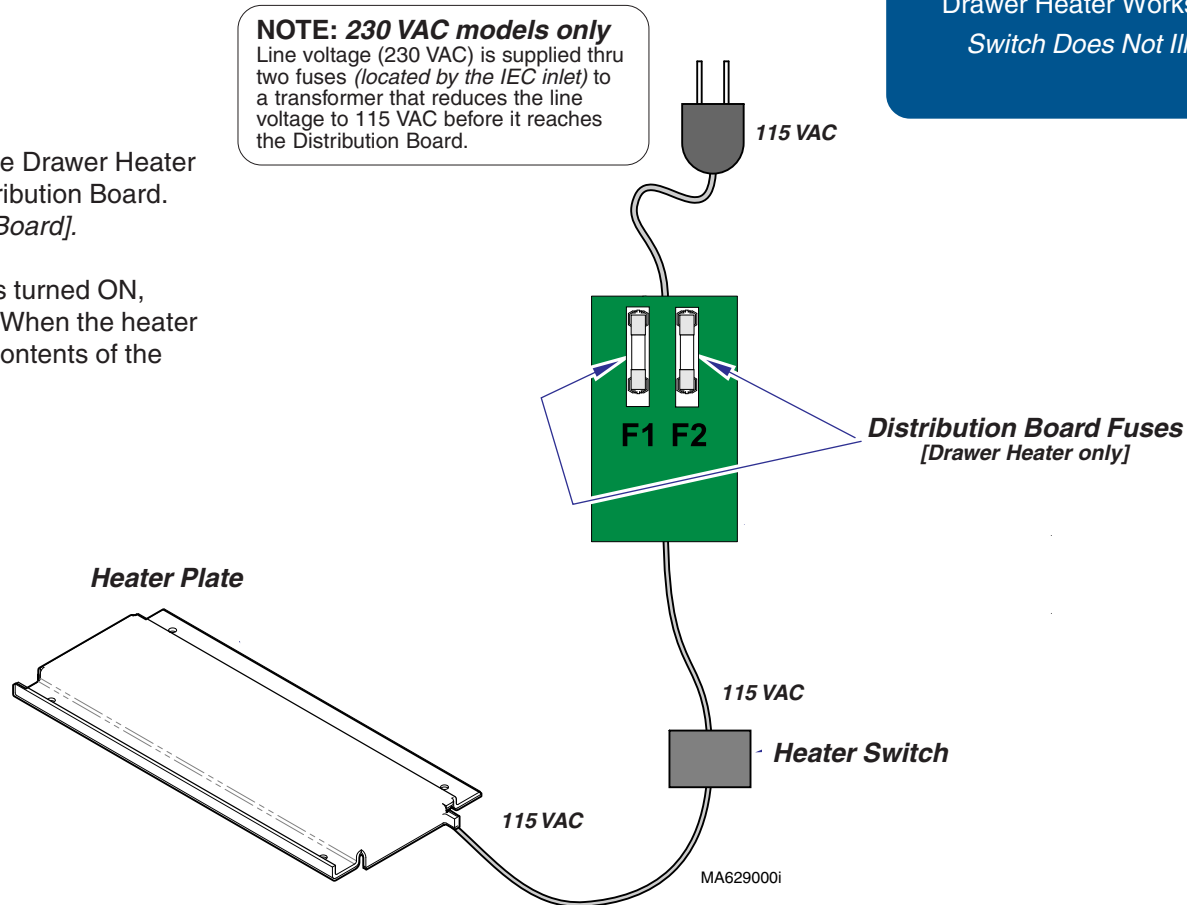

Models:	222	223	622	623
Serial Numbers:	(-003 /-004 /-007 /-008 /-010 /-016) All	(-003 /-004 /-007 /-008 /-010 /-016) All	(-002 /-004 /-006-008) All	(-002 /-004 /-008 /-010) All

Troubleshooting

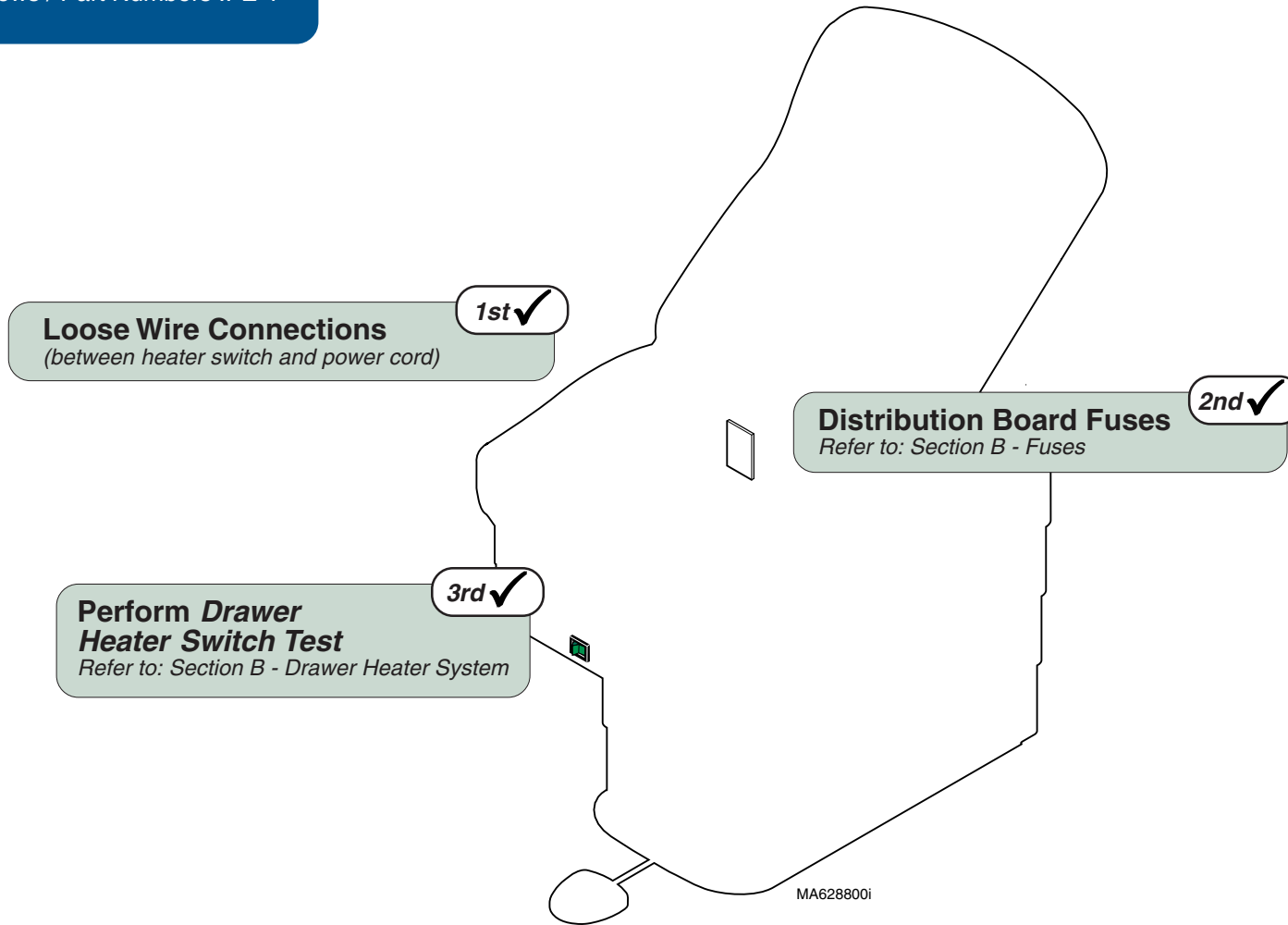

Refer To:	Page
Fuses	B-2
Drawer Heater System	B-23
Wiring Diagrams	D-1
Exploded Views / Part Numbers ..	E-1

Function	Status	Problem
Drawer Heater		Does not heat up.
Heater Switch		Does <u>not</u> illuminate



Models:	222	223	622	623
Serial Numbers:	(-003 /-004 /-007 /-008 /-010 /-016) All	(-003 /-004 /-007 /-008 /-010 /-016) All	(-002 /-004 /-006-008) All	(-002 /-004 /-008 /-010) All

Troubleshooting

Function	Status	Problem
Drawer Heater		Does not heat up.
Heater Switch		OK (<i>Illuminates</i>)

Refer To:	Page
Fuses	B-2
Drawer Heater System	B-23
Wiring Diagrams	D-1
Exploded Views / Part Numbers ..	E-1

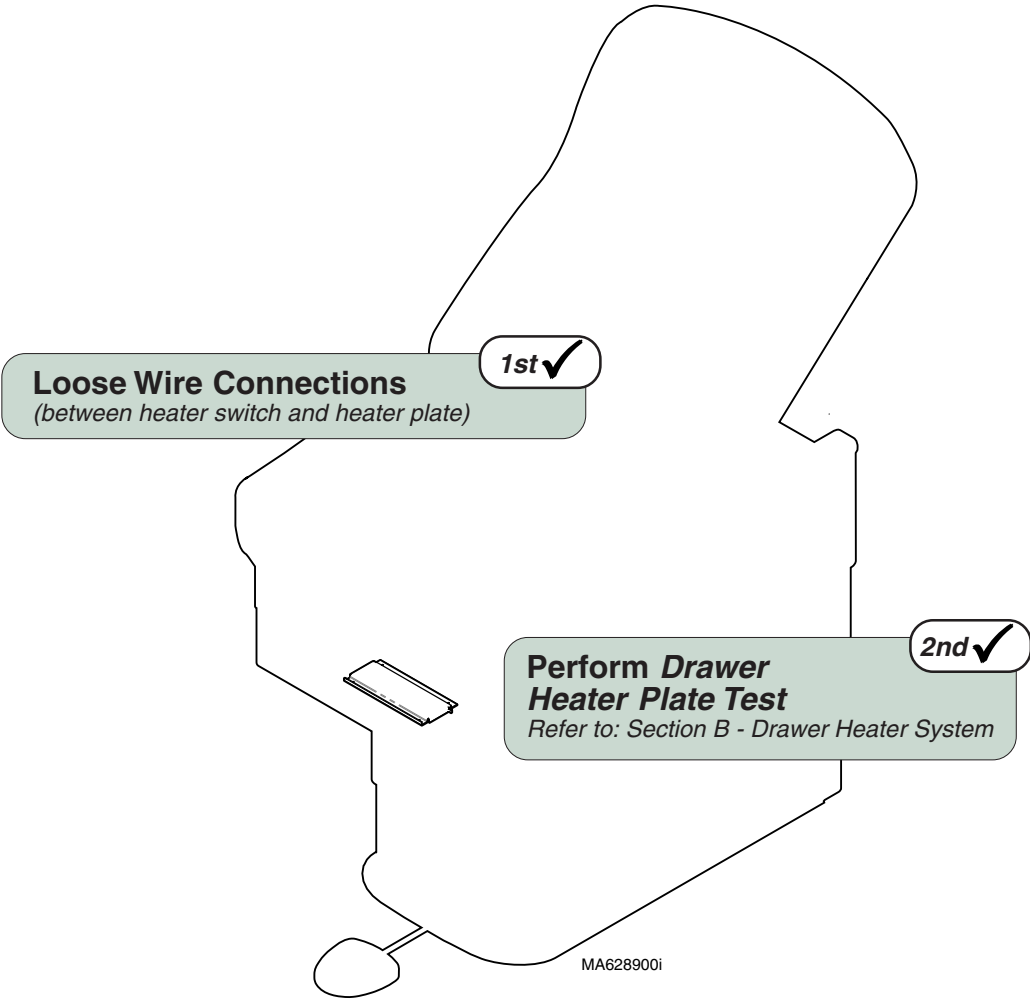



Models:	222	223	622	623
Serial Numbers:	(-003 /-004 /-007 /-008 /-010 /-016) All	(-003 /-004 /-007 /-008 /-010 /-016) All	(-002 /-004 /-006-008) All	(-002 /-004 /-008 /-010) All

Drawer Heater System

Troubleshooting

Refer To:	Page
Drawer Heater System	B-23
Wiring Diagrams	D-1
Exploded Views / Part Numbers ..	E-1

Function	Status	Problem
Drawer Heater		OK
Heater Switch		Does <u>not</u> illuminate

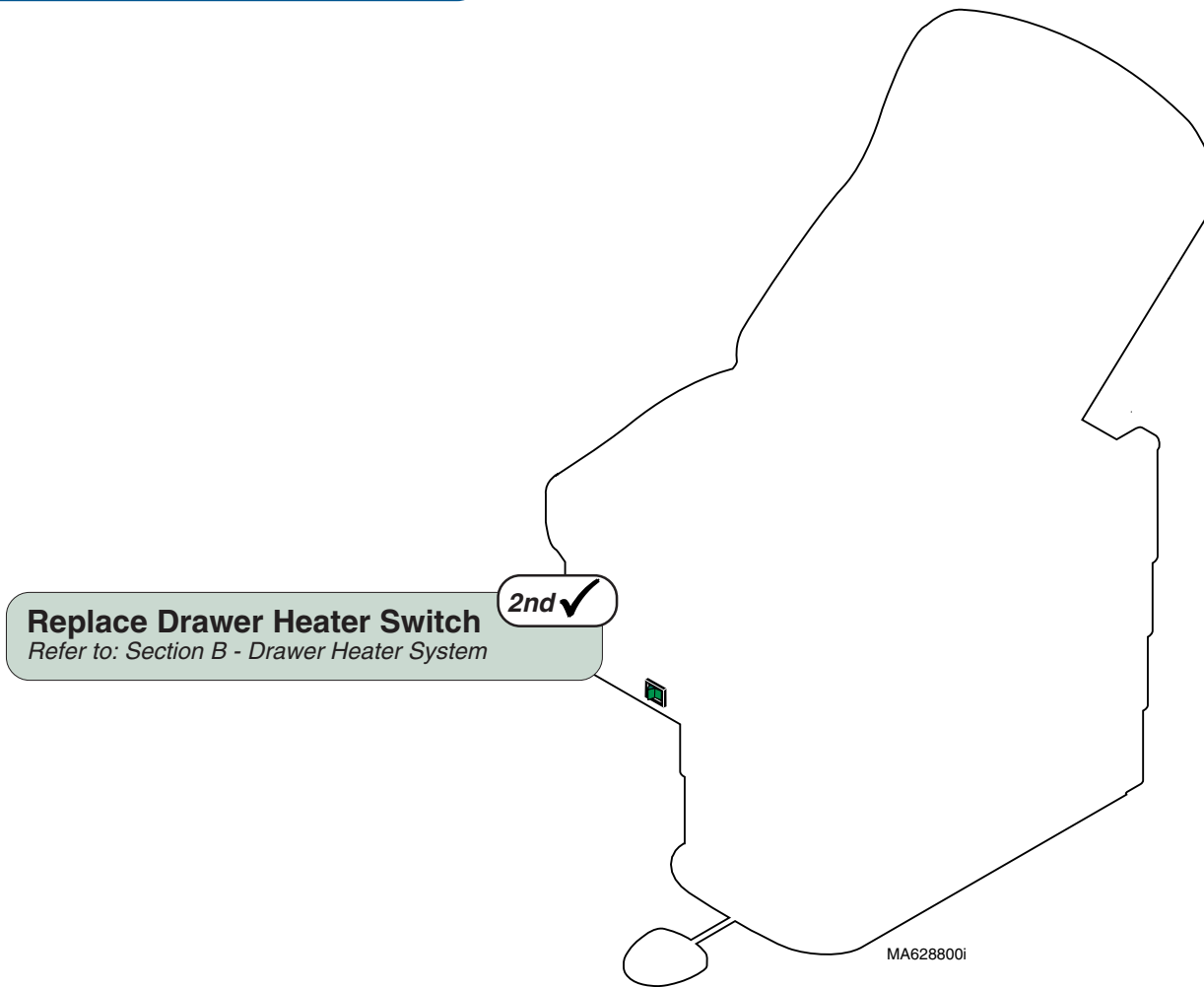

Models:	222	223	622	623
Serial Numbers:	(-003 /-004 /-007 /-008 /-010 /-016) All	(-003 /-004 /-007 /-008 /-010 /-016) All	(-002 /-004 /-006-008) All	(-002 /-004 /-008 / -010) All

Table Receptacle (optional)

This illustration shows only the components that affect the table receptacle. A detailed description of current flow also appears below.

Troubleshooting [Table Receptacle]

Problem	Page
No Power At Receptacle	A-28

Table Receptacle

115 VAC is supplied directly to the table receptacle thru the circuit breaker(s)*. [Voltage bypasses the Main PC Board].

NOTE: Models w/drawer heater only

There is a connection point for the receptacle wiring harness at the distribution board. Current does not flow thru the distribution board fuses.

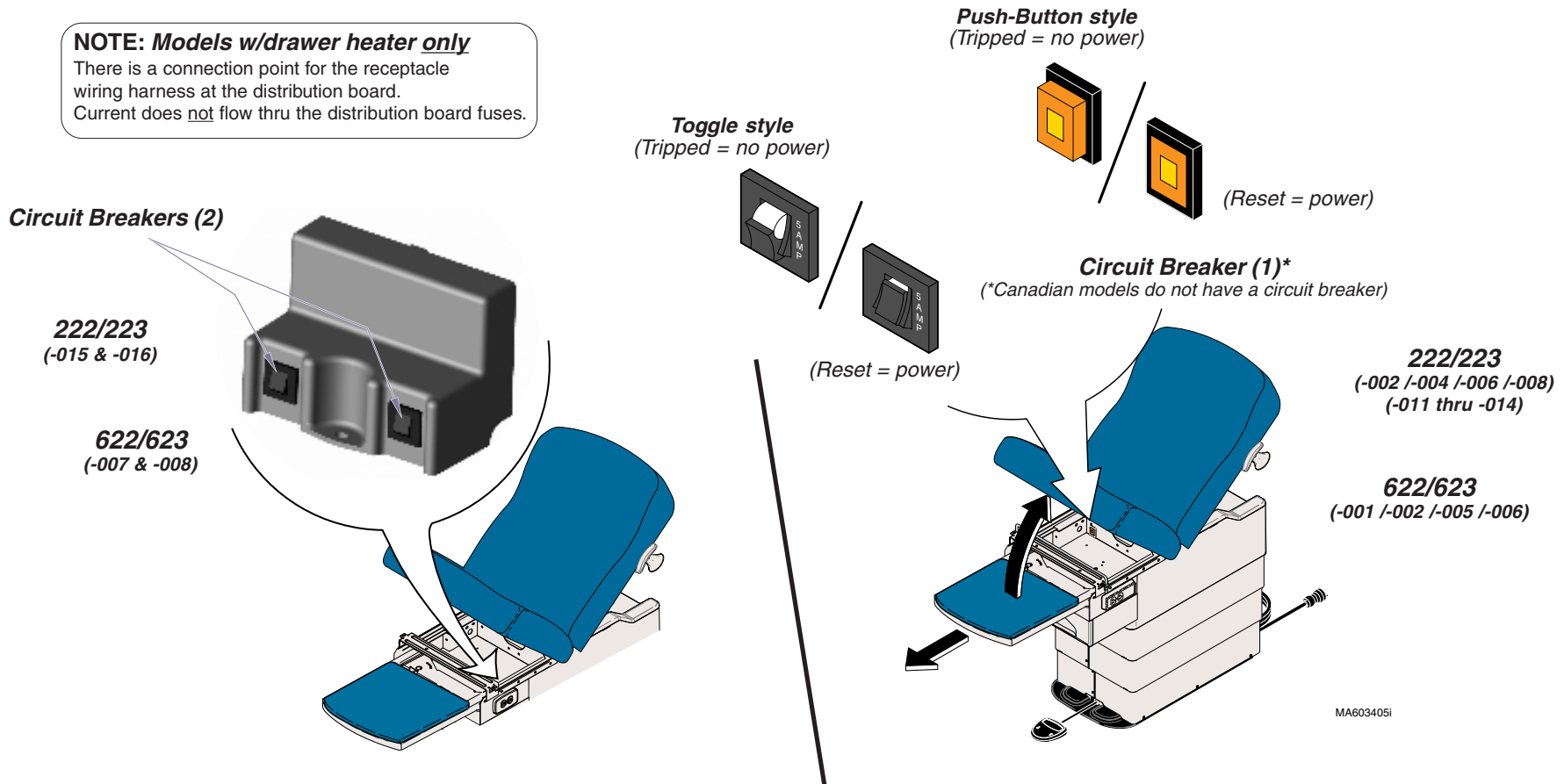



Models: Serial Numbers:	222 (-002 /-004 /-006 /-008) (-011 thru -016) All	223 (-002 /-004 /-006 /-008) (-011 thru -016) All	622 (-001 /-002) (-005 thru -008) All	623 (-001 /-002) (-005 thru -008) All
----------------------------	--	--	--	--

Table Receptacle

Troubleshooting

Refer To: **Page**
 Wiring Diagrams D-1
 Exploded Views / Part Numbers .. E-1

Function	Status	Problem
Table Receptacle		No power.
All other functions		OK

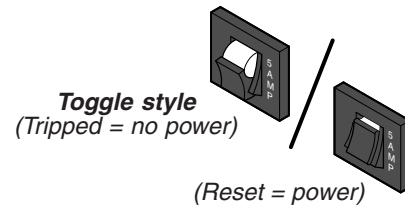

1st ✓
Is circuit breaker tripped?
[Lift seat section to access circuit breaker(s) - press to reset]

3rd ✓
Replace receptacle

2nd ✓
Loose wire connections
(between table receptacle and power cord)

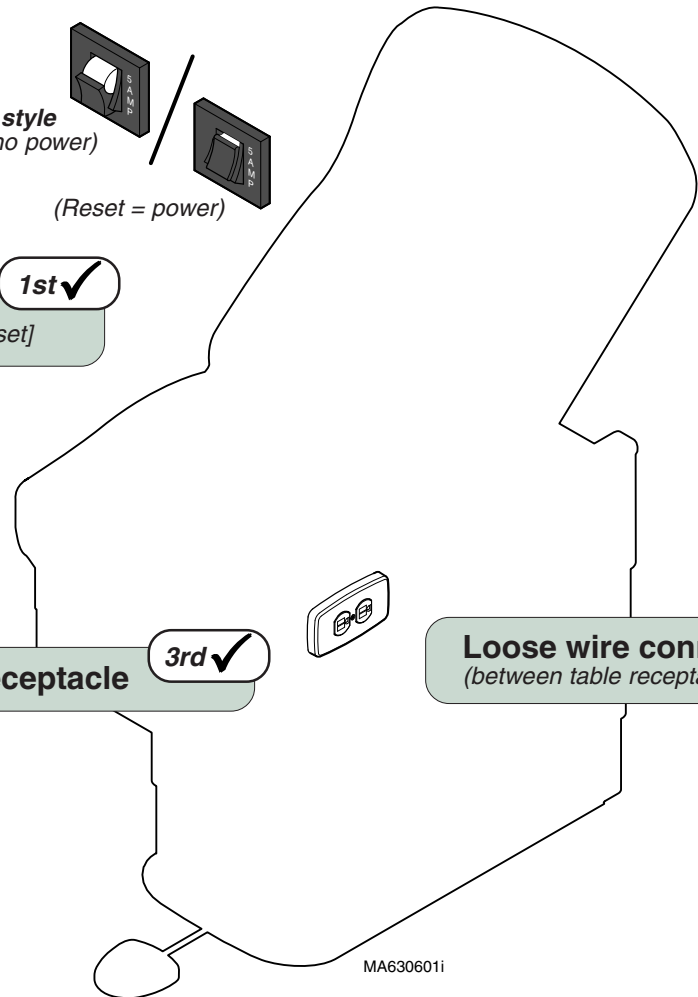

Models:	222	223	622	623
Serial Numbers:	(-002 /-004 /-006 /-008) (-011 thru -016) All	(-002 /-004 /-006 /-008) (-011 thru -016) All	(-001 /-002) (-005 thru -008) All	(-001 /-002) (-005 thru -008) All

Auto Return Function

This illustration shows only the components that affect the Auto Return function. Refer to the following page for a detailed description of current flow during this function.

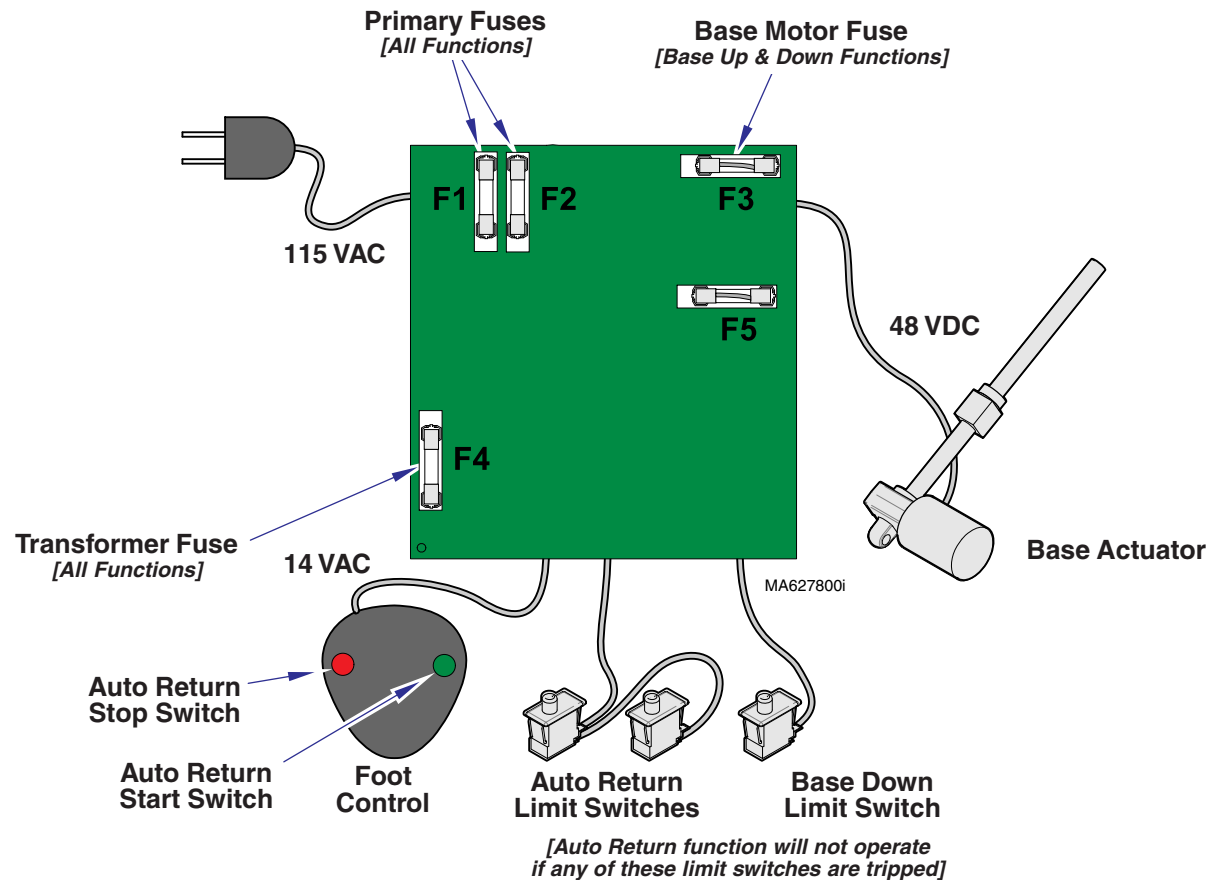

Troubleshooting [Auto Return Function]

Problem	Page
Auto Return Function Does Not Work / Base Down Function:	
Malfunctioning	A-2
Works Properly	A-31

Models: 623 (all)
Serial Numbers: All

**Auto Return
Function**

Troubleshooting

Auto Return Function

Power To Foot Control

115 VAC is supplied thru the two primary fuses (*F1 & F2*) to the transformer on the PC board. [*F4 fuse protects the transformer*].

The transformer reduces the line voltage and supplies 14 VAC to the foot control.

Auto Return Operation

NOTE

If either of the Auto Return limit switches or the Base Down limit switch are tripped (open), the Auto Return function will not operate.

When the Auto Return Switch is depressed (closed), current (*14 VAC*) flows thru the switch, to the PC Board.

NOTE

The Base Up / Down relay, located on the PC Board, has four contacts (DPDT):
(2) *Normally Open: Base Up function*
(2) **Normally Closed: Base Down function**

When this voltage is applied, current (*48 VDC*) flows to the actuator motor thru the (2) Normally Closed contacts of the Base Up / Down relay. [*The relay does not energize*].

When voltage flows to the actuator thru the Normally Closed contacts of the relay, the actuator motor runs lowering the table.

Actuator Motor runs until:

1. Stop button is depressed.
2. Auto Return limit switch(es) is tripped.
3. 18 second software time limit is reached.
4. Base Down limit switch is tripped.
5. Fuse(s) opens (blows).

[*Primary, Base Motor, Transformer fuse*]

Troubleshooting

Function	Status	Problem
Auto Return		No movement
Base Down		OK

Refer To:	Page
Limit Switches	B-4
Foot Control	B-6
Wiring Diagrams	D-1
Exploded Views / Part Numbers ..	E-1

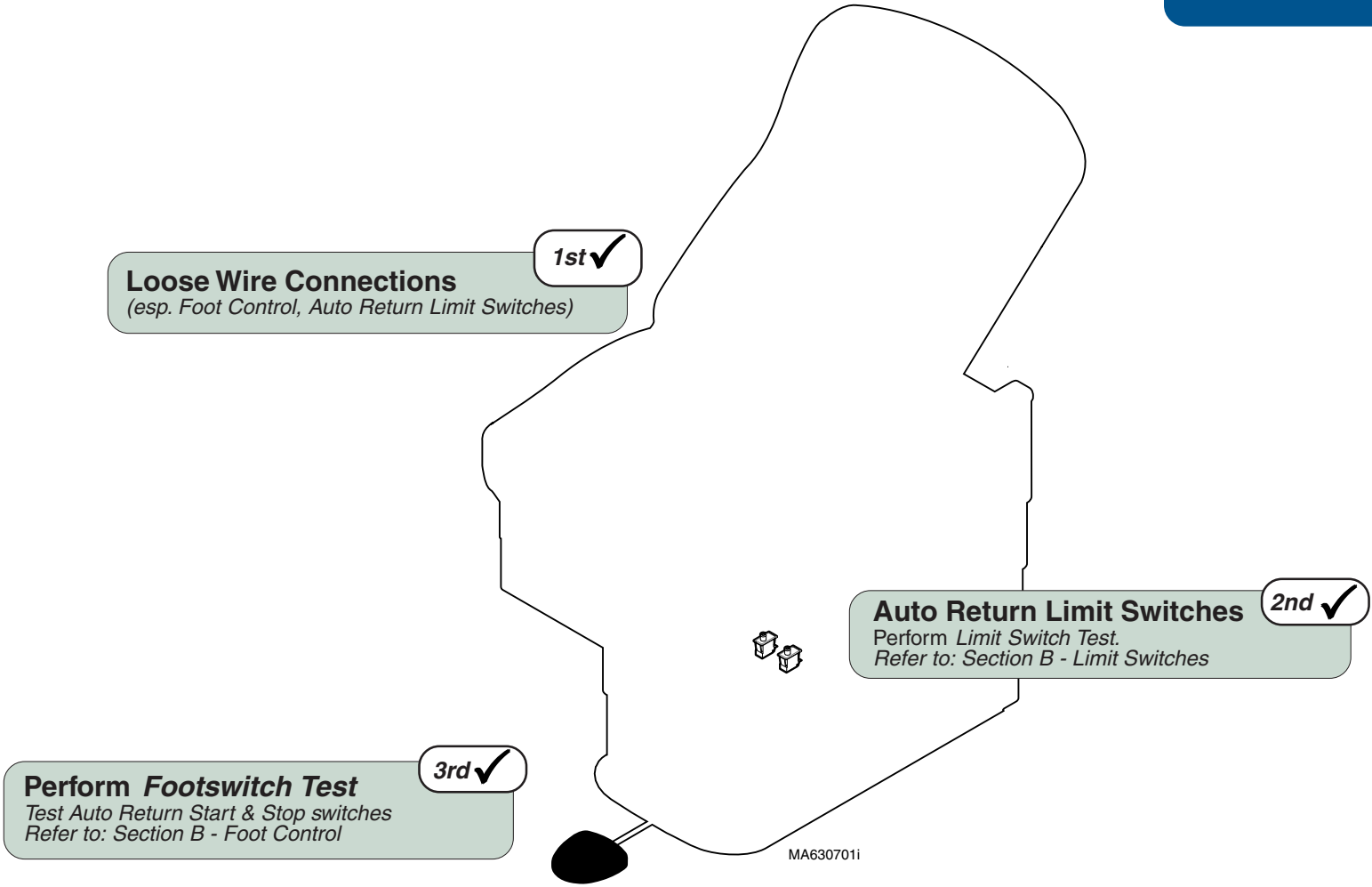

Models: 623 (all)
Serial Numbers: All

**Auto Return
Function**

Troubleshooting

Upholstery Heater System (optional)

This illustration shows only the components that affect the Upholstery Heater System. A detailed description of current flow during this function also appears below.

Upholstery Heater Operation

115 VAC is supplied thru the IEC inlet to the Distribution PC board and then to the Upholstery Heater PC board at J2 & J3. Fuses F1 and F2 protect the circuit. Circuitry on PC board converts 115 VAC to 12 VAC.

Depressing and releasing the momentary On/Off Switch supplies approximately 12 VAC to the Upholstery Heater. A timer on the PC board (*initiated when the On/Off Switch is depressed*) keeps the heater activated for an 8 hour period unless the Switch is depressed Off.

(Temperature knob not present on later models)
The upholstery heater temperature can be regulated by the operator. Turning the temperature knob will increase or decrease the voltage to the heater. The temperature can be varied to a maximum of 105° F (41° C).

A thermostat, located in Back Heating Pad, opens at 131° F (55°C) +/- 10% removing power from both Back and Seat heating elements.

Upholstery Heater runs until:

1. Stop button is depressed.
2. 8 hour time limit is reached.
3. Fuse(s) on Upholstery Heater PCB opens (blows).

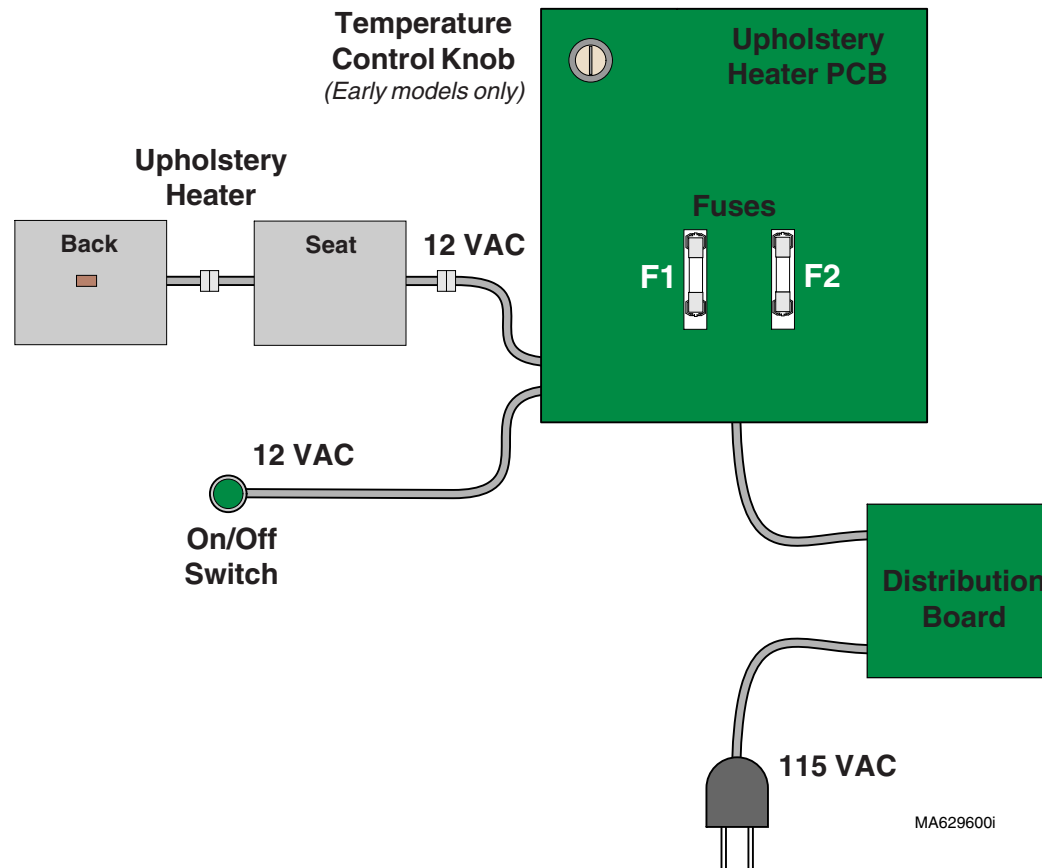

Troubleshooting [Upholstery Heater System]

Problem	Page
Heater Does <u>Not</u> Warm Up:	
Switch Does <u>Not</u> Illuminate	A-33
Switch Illuminates	A-34
Heater Works Properly:	
Switch Does <u>Not</u> Illuminate	A-35



MA629600i

Troubleshooting

Function	Status	Problem
Upholstery Heater		Does <u>not</u> heat up.
Heater Switch		Does <u>not</u> illuminate

Refer To:	Page
Fuses	B-2
Uph. Heater PC Board Test	B-29
Uph. Heater Switch Test	B-33
Wiring Diagrams	D-1
Exploded Views / Part Numbers ..	E-1

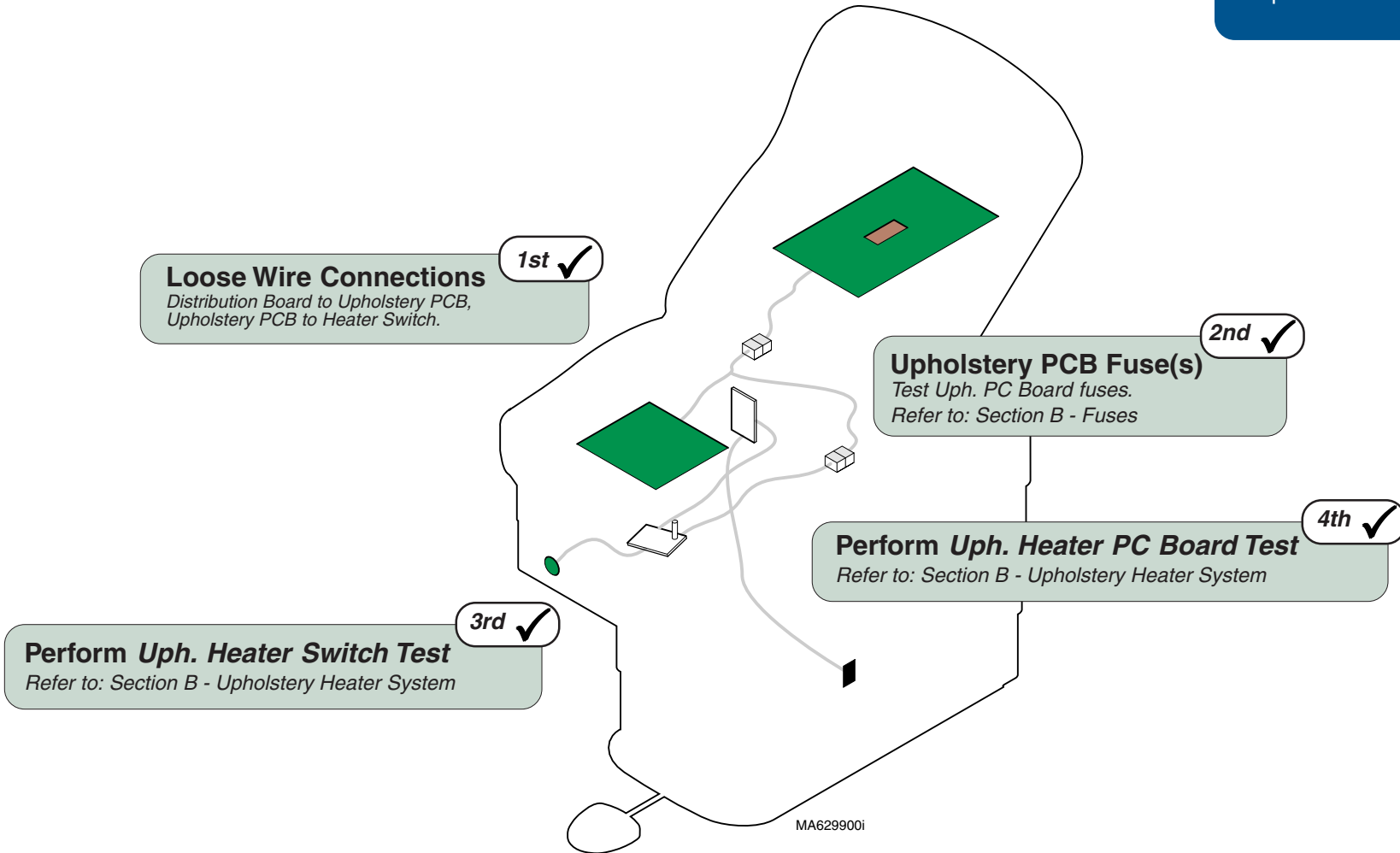



Models:	622	623
Serial Numbers:	(-002 /-004 /-006-008) All	(-002 /-004 /-008 / -010) All

Upholstery Heater

Troubleshooting



Refer To: Page

Fuses	B-2
Uph. Heater PC Board Test	B-29
Uph. Heater Test	B-32
Uph. Heater Switch Test	B-33
Wiring Diagrams	D-1
Exploded Views / Part Numbers ..	E-1

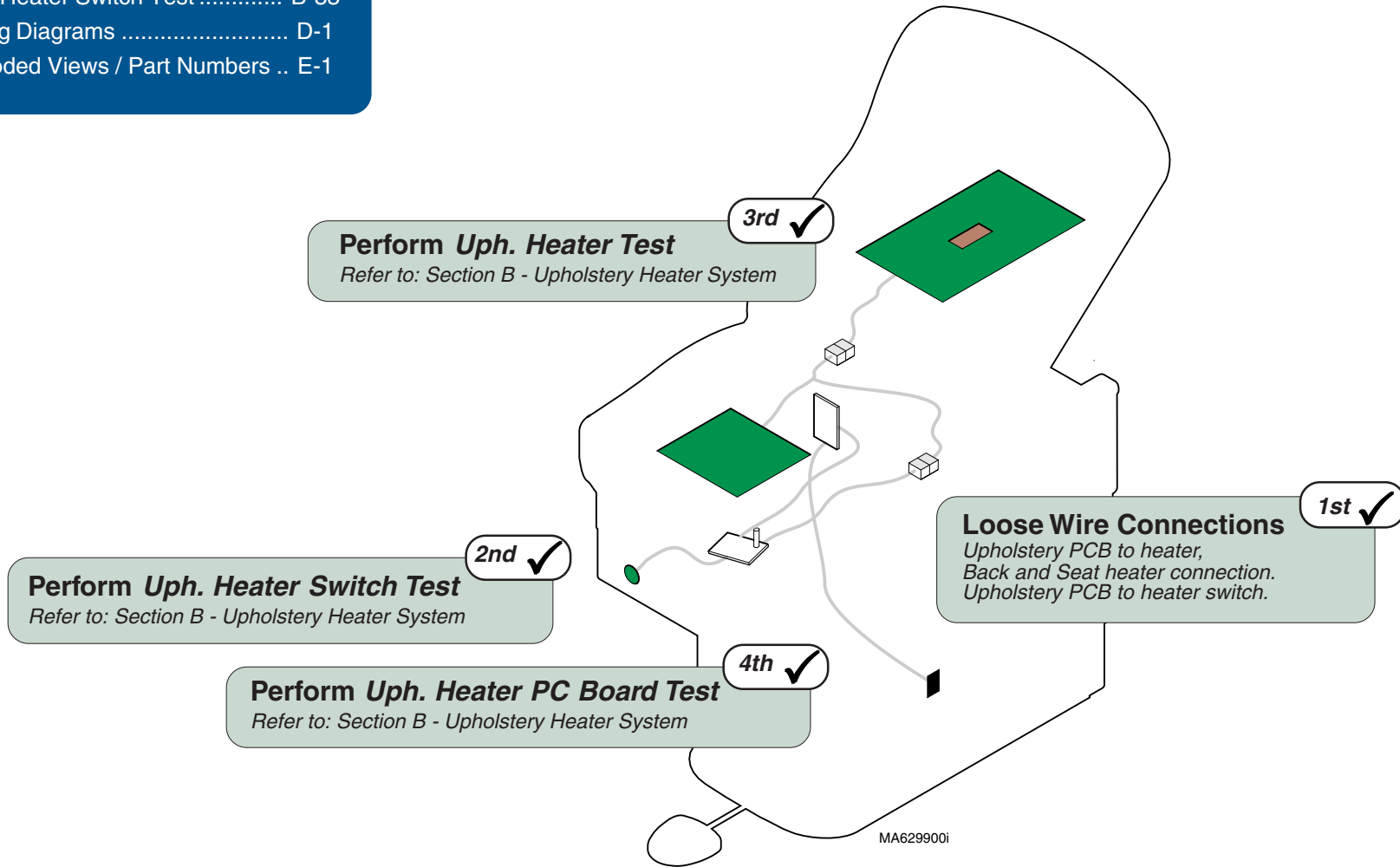
Function	Status	Problem
Upholstery Heater		Does <u>not</u> heat up.
Heater Switch		Illuminates.



Troubleshooting

Function	Status	Problem
Upholstery Heater		OK
Heater Switch		Does <u>not</u> illuminate

Refer To:	Page
Upholstery Heater Switch Replacement	B-25
Wiring Diagrams	D-1
Exploded Views / Part Numbers ..	E-1

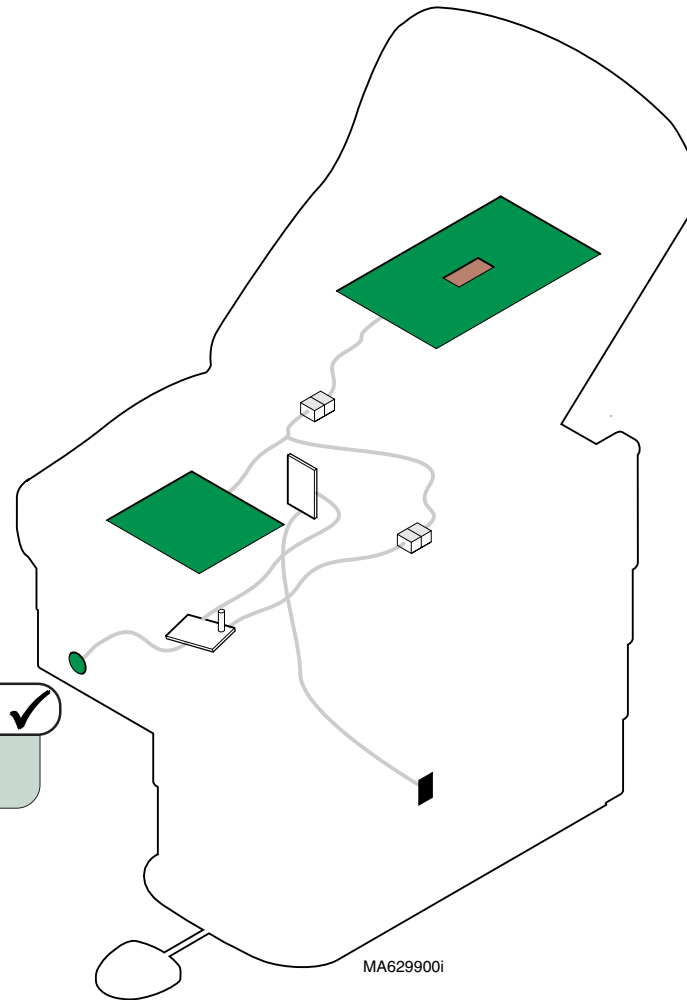

1st ✓
Replace Uph. Heater Switch
Refer to: Section B - Upholstery Heater System

Models:	622	623
Serial Numbers:	(-002 /-004 /-006-008) All	(-002 /-004 /-008 / -010) All

Upholstery Heater

Troubleshooting

Section B

Component Testing & Repair

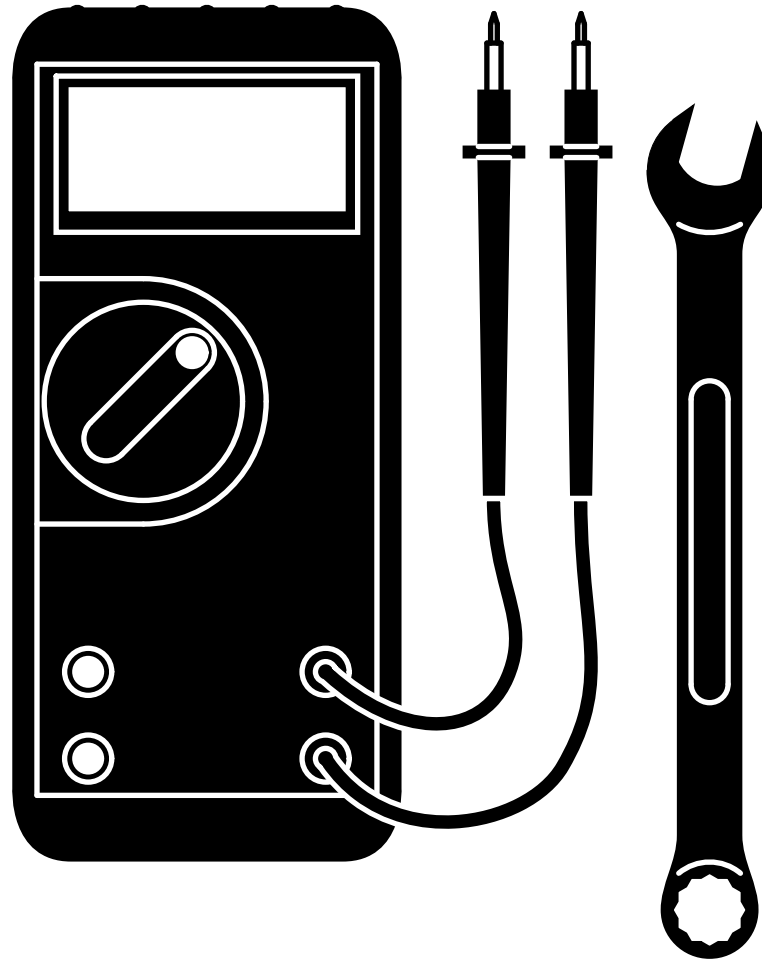

<u>Components</u>	<u>Page</u>
Fuses	B-2
Limit Switches	B-4
Foot / Hand Control	B-6
Base Actuator	B-11
Back Actuator (<i>power</i>)	B-11
Back Release Mechanism (<i>manual</i>)	B-17
Main PC Board	B-19
Drawer Heater System	B-23
Upholstery Heater System	B-29

Component Testing & Repair

Fuses

Location

Fuses	Page
Location	B-2
Fuse Test	B-3
Access Procedures	C-1
Wiring Diagrams	D-1
Fuse Ratings & Part Numbers	E-24

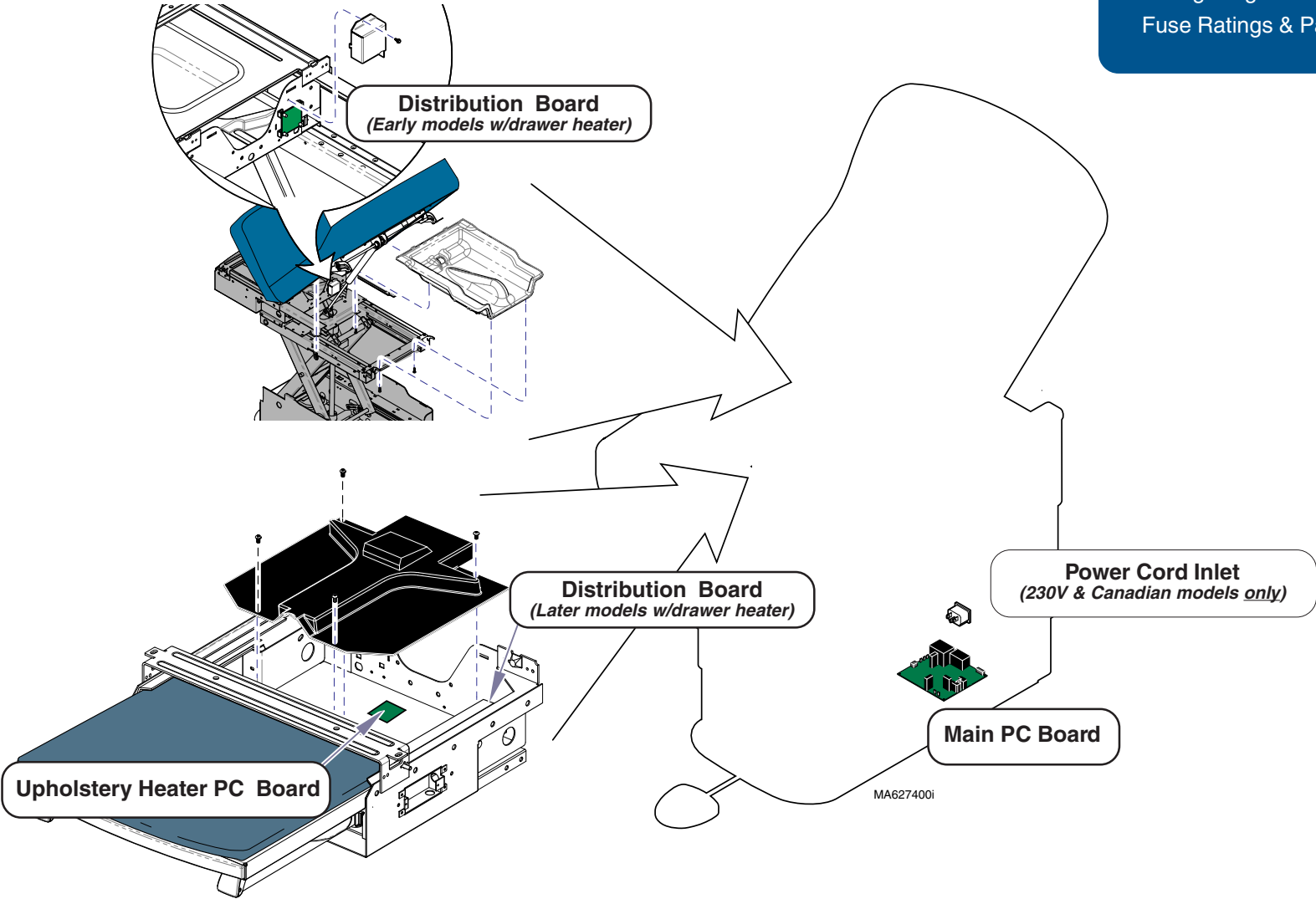



Component Testing & Repair

Fuses - continued

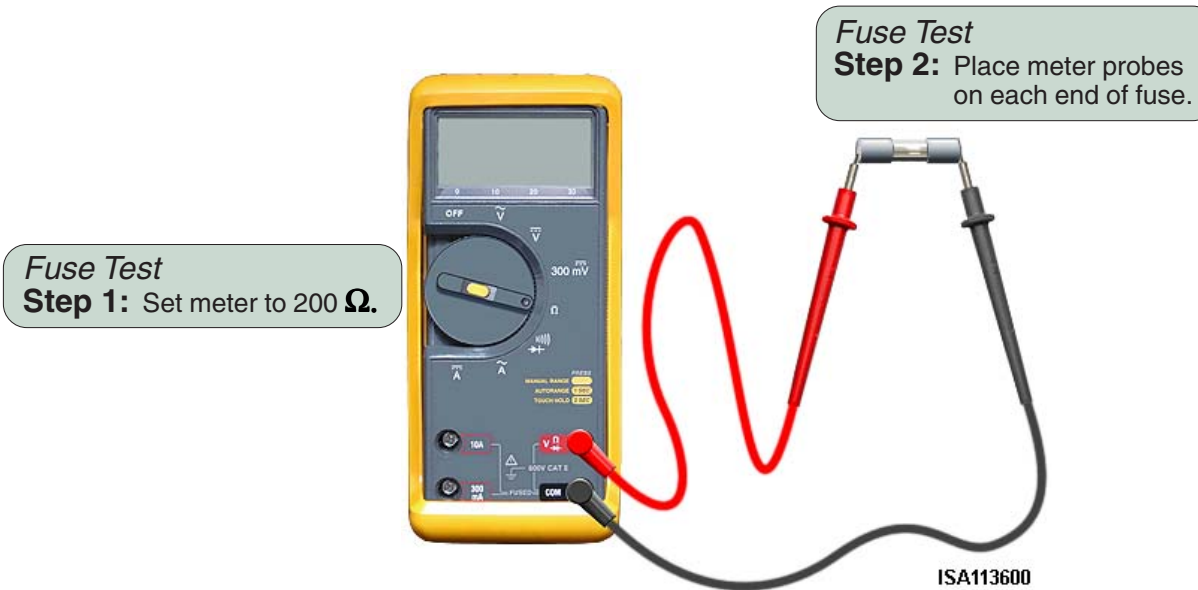
Fuse Test



Meter Reading **Status** **Required Action**

OL		Replace fuse.
Any resistance reading		Fuse is good.

Models:
Serial Numbers:

All
All

Fuses

Component Testing & Repair

Limit Switches

Location

<u>Limit Switches</u>	<u>Page</u>
Location	B-4
Limit Switch Test	B-5
Access Procedures	C-1
Wiring Diagrams	D-1
Part Number (<i>all</i>)	015-1055-00

Attention!
All limit switches are the same.
They can be "traded" to troubleshoot.

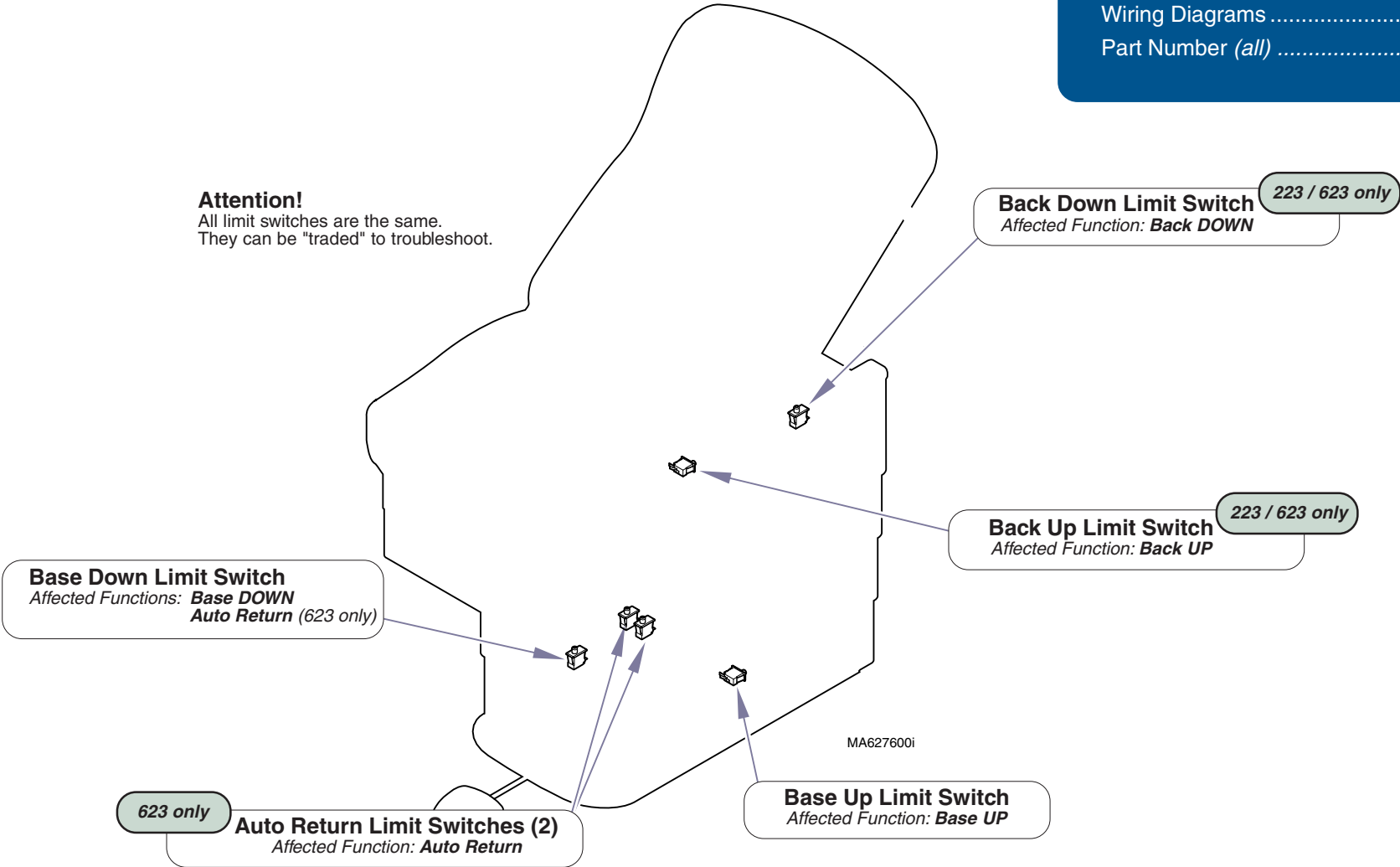

Limit Switches - continued

Limit Switch Test

Attention!

All limit switches are the same. They can be "traded" to troubleshoot.

Limit Switch Test

Step 1: Remove limit switch. Disconnect wires.

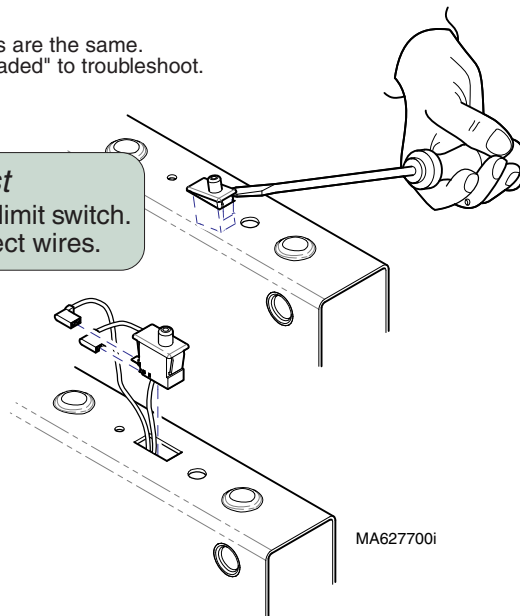

Limit Switch Test

Step 3: Place meter probes on **COM** and **NC** terminals.

Note: Check switch 'tripped' and 'untripped'.

Limit Switch Test

Step 2: Set meter to 200 Ω .

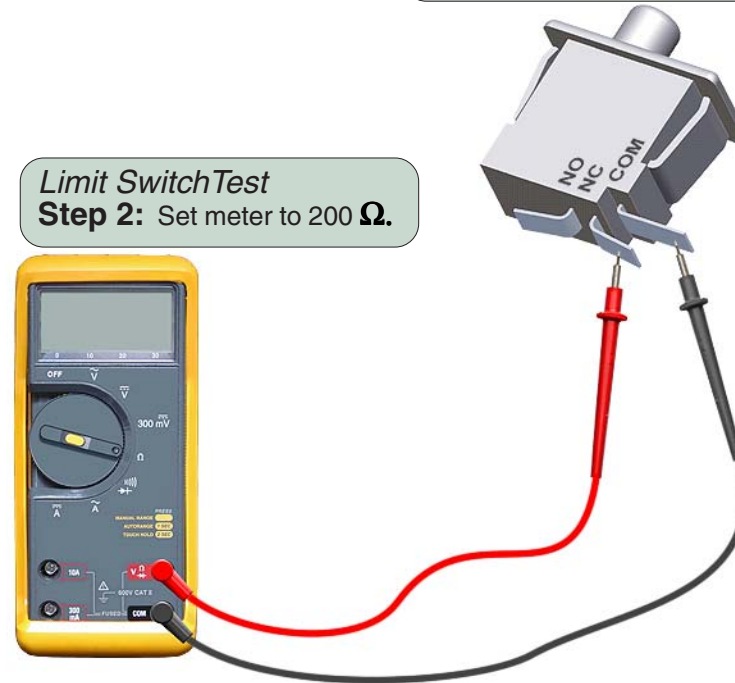

With switch 'tripped'...

Meter Reading	Status	Required Action
OL		Switch is good. Perform next check.
less than or = to 5 ohms		Replace switch

With switch 'untripped'...

Meter Reading	Status	Required Action
OL		Replace switch
Any resistance reading		Switch is good. Perform next check.

Models:
Serial Numbers:

All
All

Limit Switches

Component Testing & Repair

Foot / Hand Control

Foot Switch Test - 222 / 622

Foot Switch Test
Step 1: Remove foot control switch.
Note: Refer to **Foot Switch Replacement 222 / 622**.

Foot Switch Test
Step 2: Set meter to Ω .

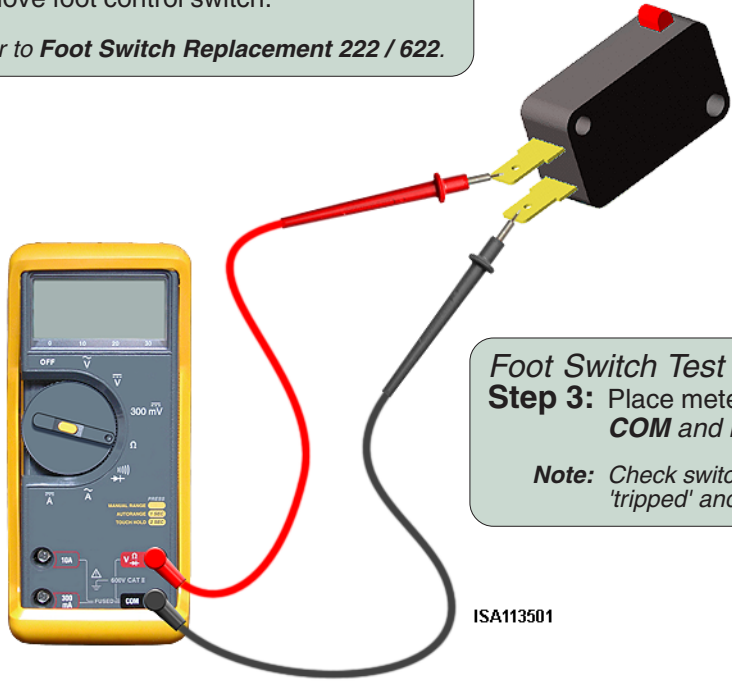

Foot Switch Test
Step 3: Place meter probes on **COM** and **NO** terminals.
Note: Check switch 'tripped' and 'untripped'.

<u>Foot / Hand Control</u>	<u>Page</u>
Foot Switch Test - 222 / 622	B-6
Foot / Hand Control Test - 223 / 623	B-7
Foot Switch Replacement:	
222 / 622	B-8
223 / 623 (old style foot control)	B-9
Switch Membrane Replacement:	
223 / 623 (new style foot control)	B-10
623 Hand Control	B-10
Wiring Diagrams	D-1
Exploded View / Part Numbers:	
Foot Control - 222 / 622	E-26
Foot Control - 223	E-27*
Foot Control - 623	E-28*
Hand Control - 623	E-29

** multiple pages due to model / serial # break*

With switch 'tripped'...

Meter Reading	Status	Required Action
less than or = to 5 ohms		Switch is good. Perform next check.
OL		Replace switch

With switch 'untripped'...

Meter Reading	Status	Required Action
Any resistance reading		Replace switch.
OL		Switch is good. Perform next check.

Component Testing & Repair

Foot / Hand Control - continued

Foot / Hand Control Test - 223 / 623

Foot / Hand Control Test

Step 1: Disconnect wire harness from J8* on main PC board.

** Note: Model 623 only: If the foot or hand control to be tested is plugged into the inlet at the head end of the table, disconnect harness from J7 on main PC board.*

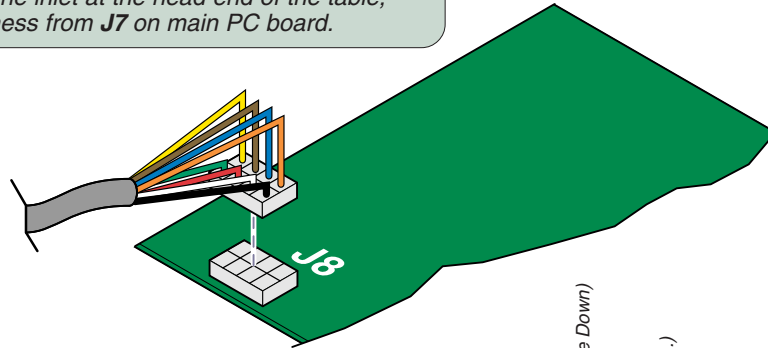

Foot / Hand Control Test
Step 2: Set meter to Ω .

Foot / Hand Control Test

Step 3: Place one meter probe on black wire (*common*) of foot / hand control harness.

Place other meter probe on the wire that corresponds to the switch to be tested:

<u>Switch</u>	<u>Wire Color</u>
Base Up	white
Base Down	red
Back Up	green
Back Down	orange
Auto Return	blue
Stop	brown

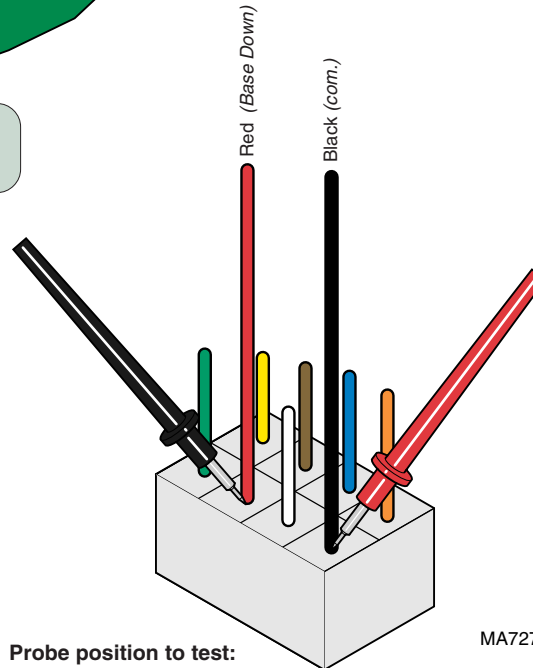

Probe position to test:
Base Down switch

MA727300i

With switch 'untripped'...

Meter Reading	Status	Required Action
Any resistance reading		Replace switch / switch membrane.
OL		Switch is good. Perform next check.

With switch 'tripped'...

Meter Reading	Status	Required Action
less than or = to 5 ohms		Switch is good. Perform next check.
OL		Replace switch / switch membrane.

Models:
Serial Numbers:

223 (all)
All

623 (all)
All

Foot / Hand Control

© Midmark Corporation 2003 SF-1838

Component Testing & Repair

Foot / Hand Control - continued

Foot Switch Replacement - 222 / 622

Removal

Step 1: Remove cover.

Installation

Step 2: Install cover.

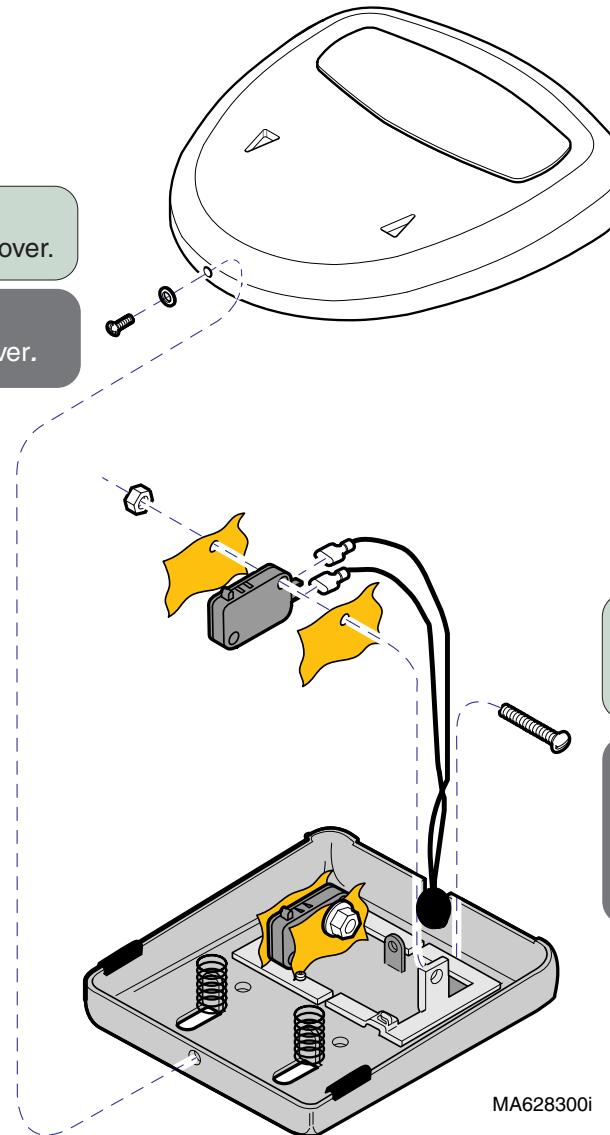

Removal

Step 2: Remove switch.
Disconnect wires.

Installation

Step 1: Install switch.
Connect wires.

Note: Be sure insulating material is in place.

Component Testing & Repair

Foot / Hand Control - continued

Foot Switch Replacement - 223 / 623*

* Old-style Foot Control

Installation

Step 3: Connect coil cord & pedal switch wire harness to PC board.

Removal

Step 3: Disconnect coil cord & pedal switch wire harness from PC board.

Removal

Step 1: Disconnect coil cord from table. Remove strain relief clamp.

Installation

Step 5: Install strain relief clamp. Connect coil cord to table.

Removal

Step 2: Remove four screws. Separate top section.

Installation

Step 4: Install top section.

Installation

Step 2: Insert switch wires into connector. Connect wire harness to PC board.

Removal

Step 4: Disconnect proper wire harness from PC board. Press tabs, then disconnect faulty switch wires.

Installation

Step 1: Install switch.

Removal

Step 5: Remove faulty switch.

MA633200i

Models:	223 (-001 thru -014)	623 (-001 thru -006)
Serial Numbers:	SC1000 thru present SE1000 thru present V2200 thru V3302	SD1000 thru present SF1000 thru present SL1000 thru present V2200 thru V3302

Foot / Hand Control

Component Testing & Repair

Foot / Hand Control - continued

Switch Membrane Replacement - 223 / 623*

* New-style Foot Control

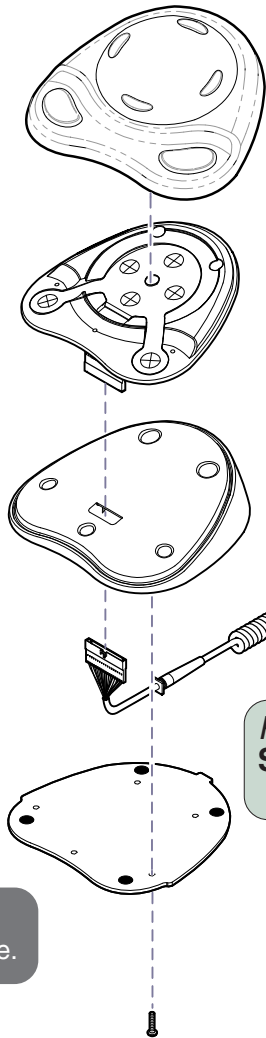

Installation

Step 1: Install touch pad onto switch panel.

Removal

Step 3: Peel touch pad off of switch panel.

Installation

Step 2: Insert control cord thru hole in base.
Connect to membrane connector.

Note: Slide strain relief block (on cord) into slot on base.

Removal

Step 2: Disconnect control cord
from membrane connector.

Removal

Step 1: Remove base plate.

Installation

Step 3: Install base plate.

MA727600i

Hand Control - 623 only

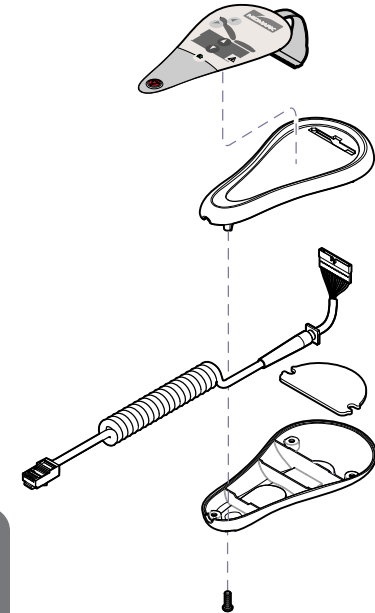

Base / Back Actuator

This illustration shows the three serviceable components of the actuator. Use the table below to isolate the malfunctioning part.

<i>Problem</i>	<i>Required Action</i>
Motor runs, but makes grinding noise.	Clean Ball Screw threads. -or Replace Ball Screw Assy.
Motor runs, but table does not move.	Inspect / replace Motor Coupler.
Motor does not run.	Perform Actuator Motor Test

<u>Base / Back Actuator</u>	<u>Page</u>
Actuator Motor Test	B-12
Replacement:	
<i>Base Actuator</i>	B-13
<i>Back Actuator (223 / 623)</i>	B-15
Wiring Diagrams	D-1
Exploded View / Part Numbers:	
<i>Back Actuator (223 / 623)</i>	E-12
<i>Base Actuator</i>	E-21

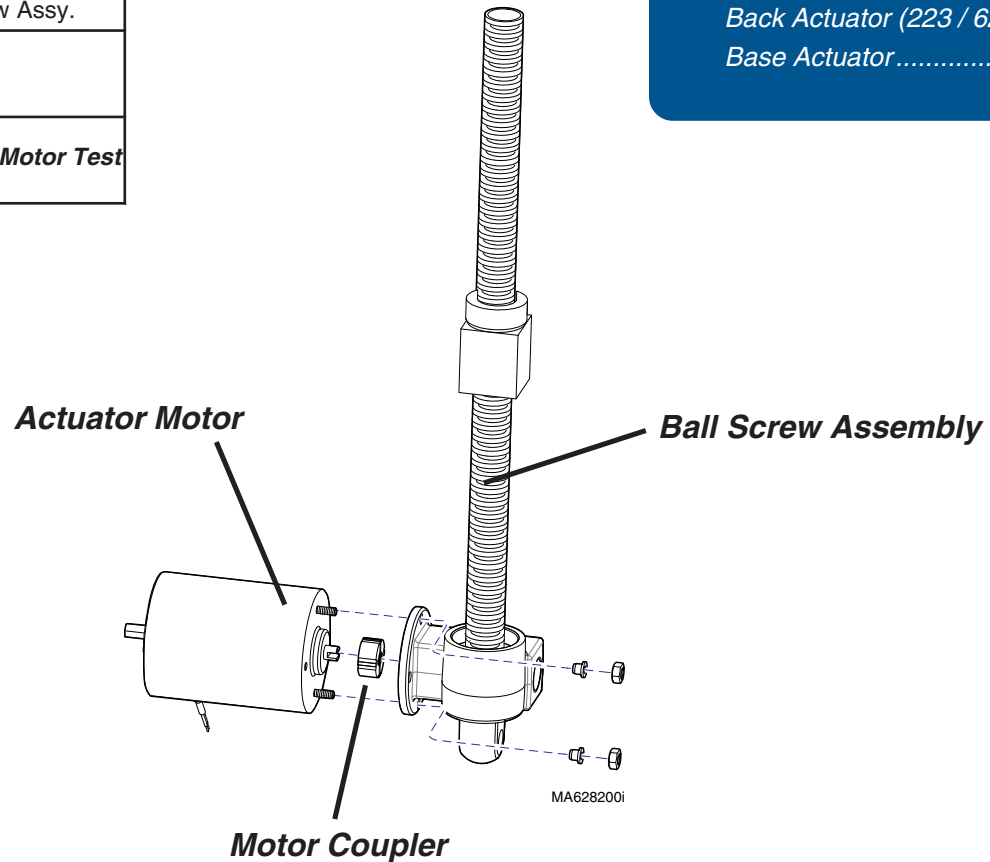

Models: | **All**
Serial Numbers: | **All**

Component Testing & Repair

Base / Back Actuator - continued

Actuator Motor Test



Caution
Unplug power cord before removing PC Board cover.

Actuator Motor Test

Step 1: Disconnect actuator wires from PC Board.
[Base Actuator: J2 & J3]
[Back Actuator: J4 & J5 (223 / 623 only)]

Note: Refer to next page to access PC Board.

Actuator Motor Test
Step 2: Set meter to 200 Ω .

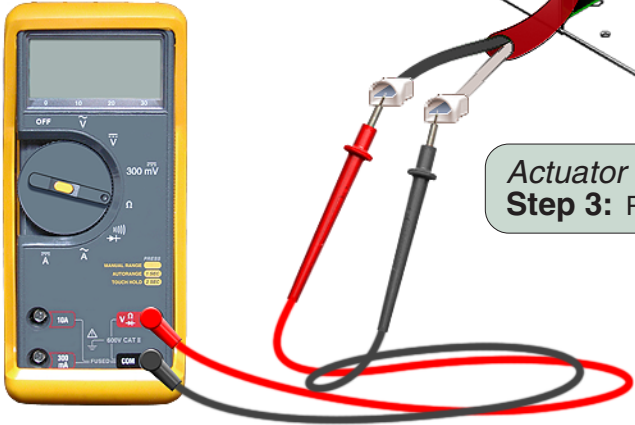

Actuator Motor Test
Step 3: Place meter probes on actuator wires.

ISA113700

Meter Reading	Status	Required Action
2- 3 Ω		Motor is good. Perform next check.
0 Ω		Replace motor.

Component Testing & Repair

Base Actuator

Replacement

Access Procedures

Page

Table Shrouds

Removal / Installation C-2

Manually Raising / Lowering Table C-5

Removal (see Access Procedures)

Step 1: Remove table shrouds.

Installation (see Access Procedures)

Step 7: Replace table shrouds.

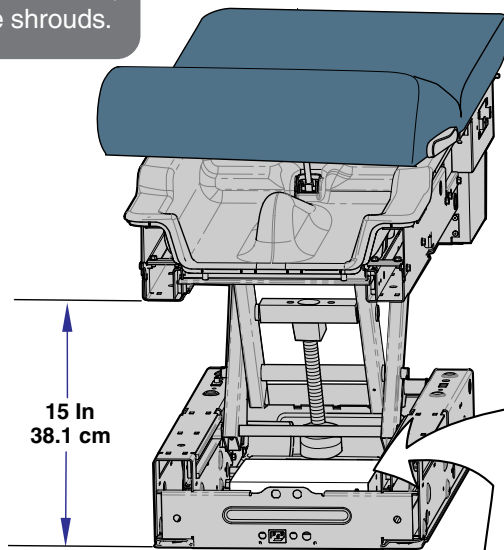

15 In
38.1 cm

Removal

Step 2: Position table so that bottom of upperwrap is approx. 15 in. from floor.

Note: If necessary, manually raise / lower table. (see Access Procedures)



Caution

Unplug power cord before removing PC Board cover.

Removal

Step 3: Remove PC Board cover.

Installation

Step 6: Replace PC Board cover.

Installation

Step 4: Connect base actuator motor wires.

Note: Clamp must be installed over stripped portion of actuator wire.

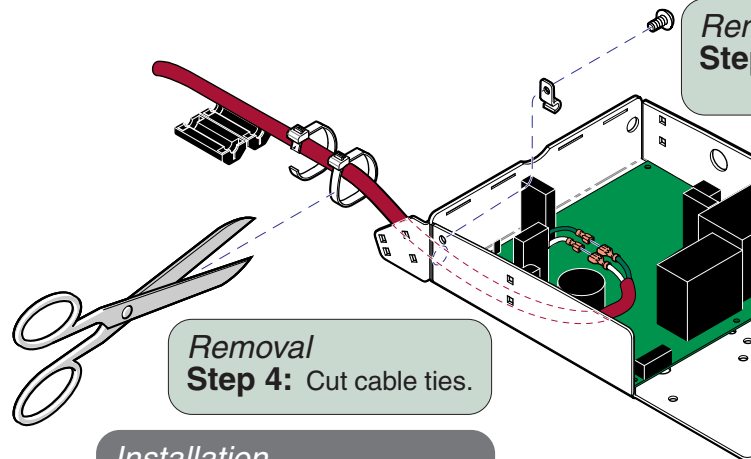

Removal

Step 5: Disconnect base actuator motor wires.

Removal

Step 4: Cut cable ties.

Installation

Step 5: Replace cable ties.

MA628000i

Models:
Serial Numbers:

All
All

Base / Back Actuator

B-13

Component Testing & Repair

Base Actuator - continued

Replacement - continued



Caution

Use an assistant when laying / lifting table.
Remove all accessories (chair arms, storage pod, etc.)

Removal

Step 6: Lay table down on LH side.

Installation

Step 3: Carefully lift table upright.

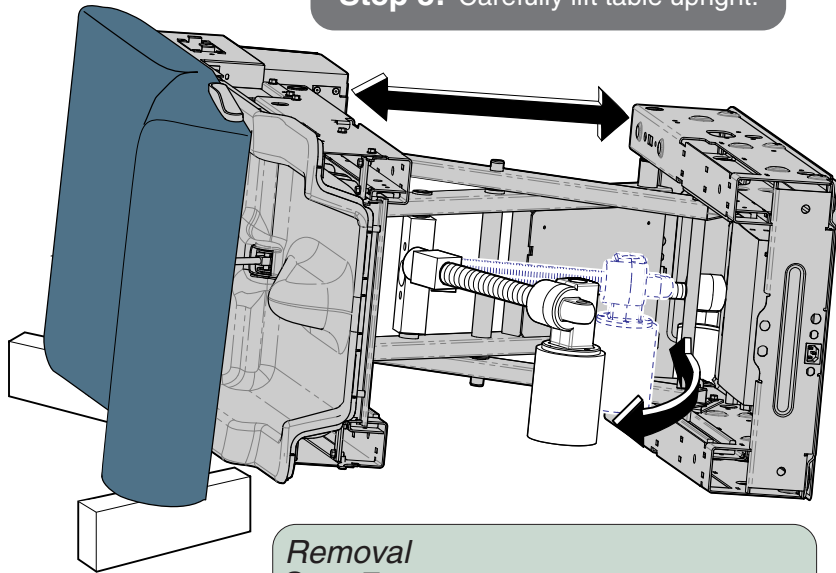

Removal

Step 7: Remove clevis pin.
Pull base out to its full extension.
Pivot actuator toward head end.

Installation

Step 2: Pivot actuator toward foot end.
Push base together.
Install clevis pin & clip ring.

Newer Models

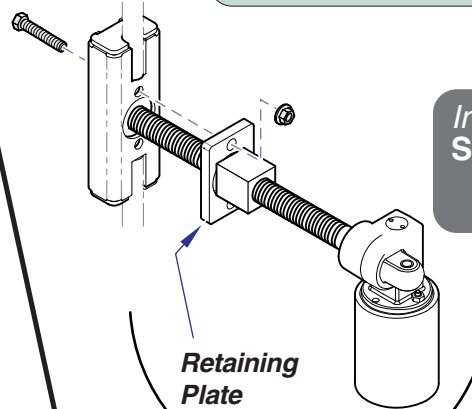

Removal

Step 8: Remove two nuts / hex bolts.

Newer models: Remove actuator. Unscrew retaining plate.

Older models: Remove U-plate.

Unscrew actuator block from mounting block.

Installation (Newer Models)

Step 1: Thread retaining plate onto actuator block.
Insert actuator thru mounting block.
Secure retaining plate to mounting block.

Retaining Plate

Older Models

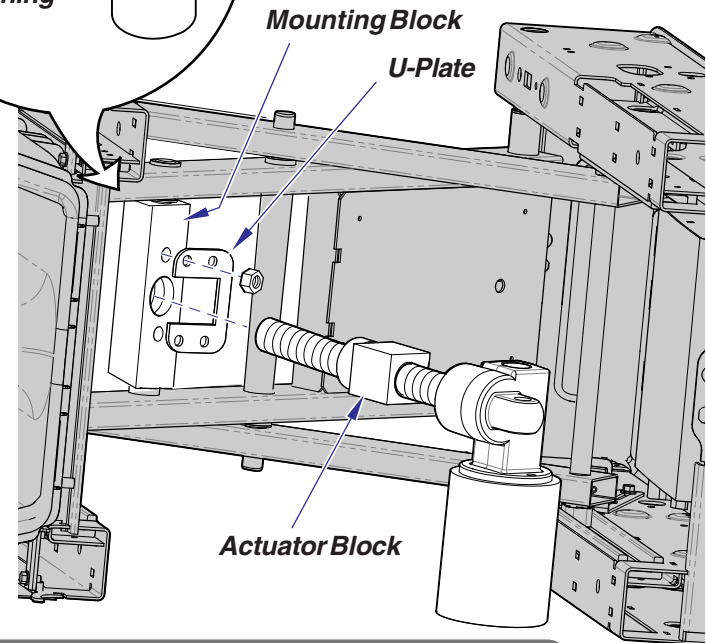

Mounting Block

U-Plate

Actuator Block

Installation (Older Models)

Step 1: Thread actuator block 1/2 way down shaft.
Thread actuator block into mounting block.
Install U-plate.

MA628100i

Back Actuator

Replacement

[Access Procedures](#)

[Page](#)

Table Shrouds

Removal / Installation C-2

Removal (see Access Procedures)

Step 1: Remove outer shrouds.

Note: The inner and middle shrouds will drop down. It is not necessary to remove them.

Installation

Step 8: Replace shrouds.

Removal

Step 4: Cut all cable ties.

Installation

Step 6: Replace all cable ties.

Removal

Step 3: Disconnect back actuator motor wires.

Installation

Step 5: Connect back actuator motor wires.



Caution

Unplug power cord before removing PC Board cover.

Removal

Step 2: Remove PC Board cover.

Installation

Step 7: Replace PC Board cover.

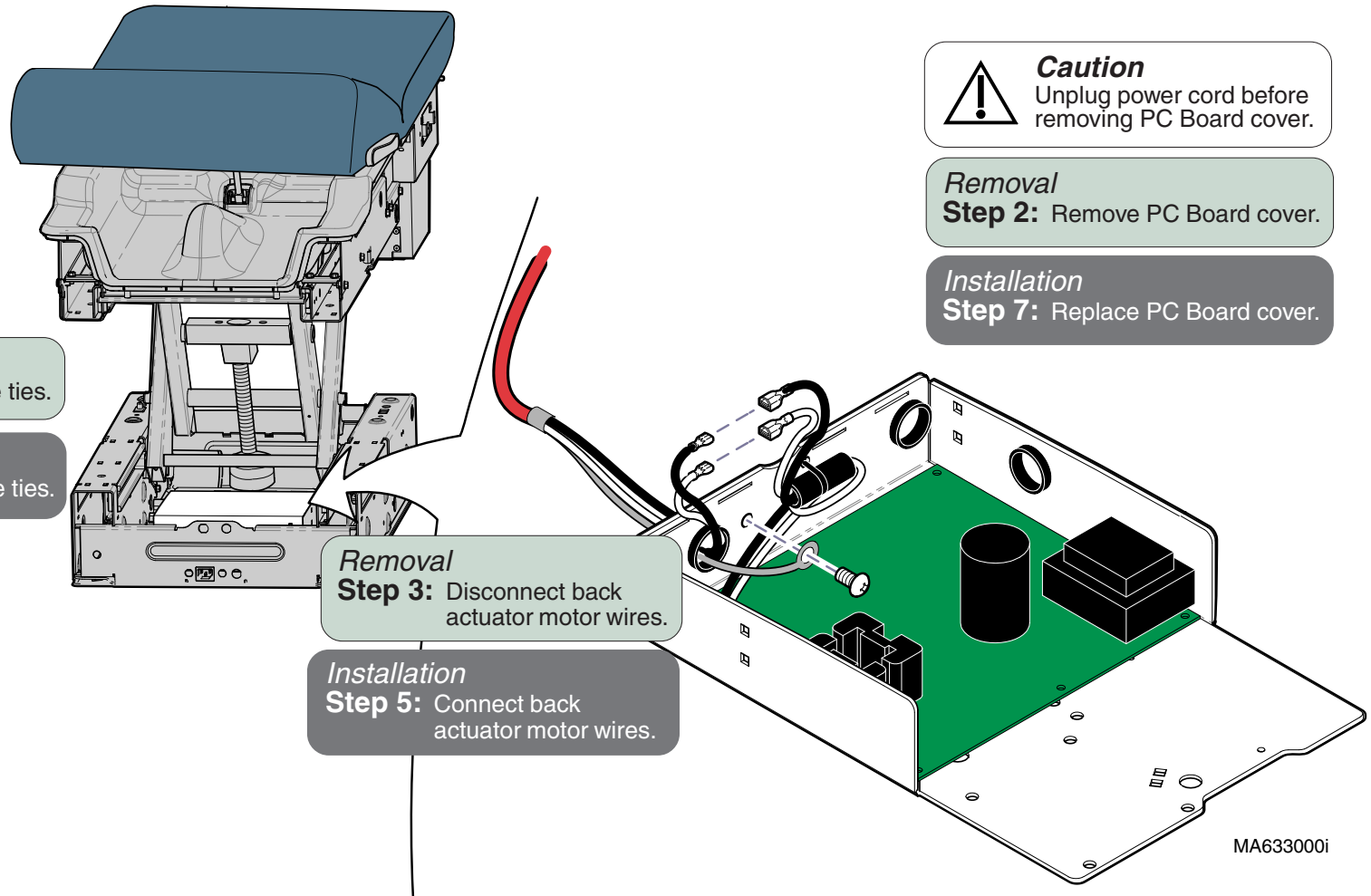

Models:
Serial Numbers:

223 (all)
All

623 (all)
All

Base / Back Actuator

B-15

Component Testing & Repair

Back Actuator - continued

Replacement - continued

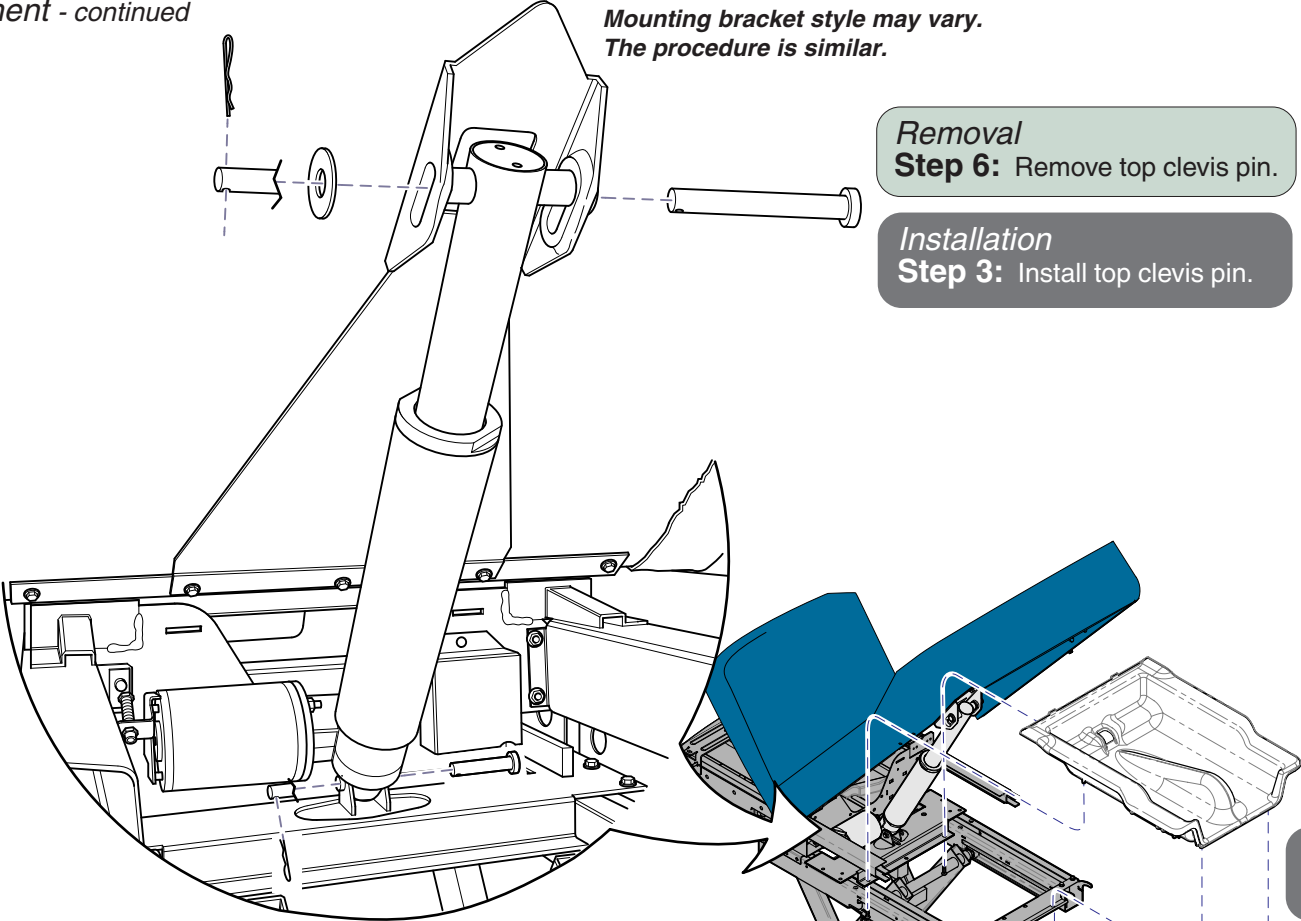

Removal
Step 6: Remove top clevis pin.

Installation
Step 3: Install top clevis pin.

Removal
Step 7: Remove top cover.

Installation
Step 2: Slide top cover over actuator.

Removal
Step 8: Remove bottom clevis pin.
Remove actuator.

Installation
Step 1: Route motor wires.
Install bottom clevis pin.

Removal
Step 5: Remove four screws
securing top cover.

Installation
Step 4: Secure top cover with four screws.

MA633901i

Back Release Mechanism

Back Release Handle Adjustment

Back Release Mechanism	Page
Back Release Handle Adjustment	B-17
Gas Cylinder	
Replacement & Adjustment	B-18
Exploded View / Part Numbers	E-10*

* multiple pages due to model / serial # break

Handle Adjustment

Step 1: Raise back section.

Note: If back section will not move, lift seat section then remove clevis pin from bottom of gas cylinder.

Handle Adjustment

Step 3: Rotate cam until cylinder releases. Rotate cam back until cylinder locks in place. Hold cam in place.

Handle Adjustment

Step 4: Pivot handles down until they contact back section.

Note: Cam should not move.

Handle Adjustment

Step 2: Loosen two set screws.

Handle Adjustment

Step 5: Tighten two set screws.

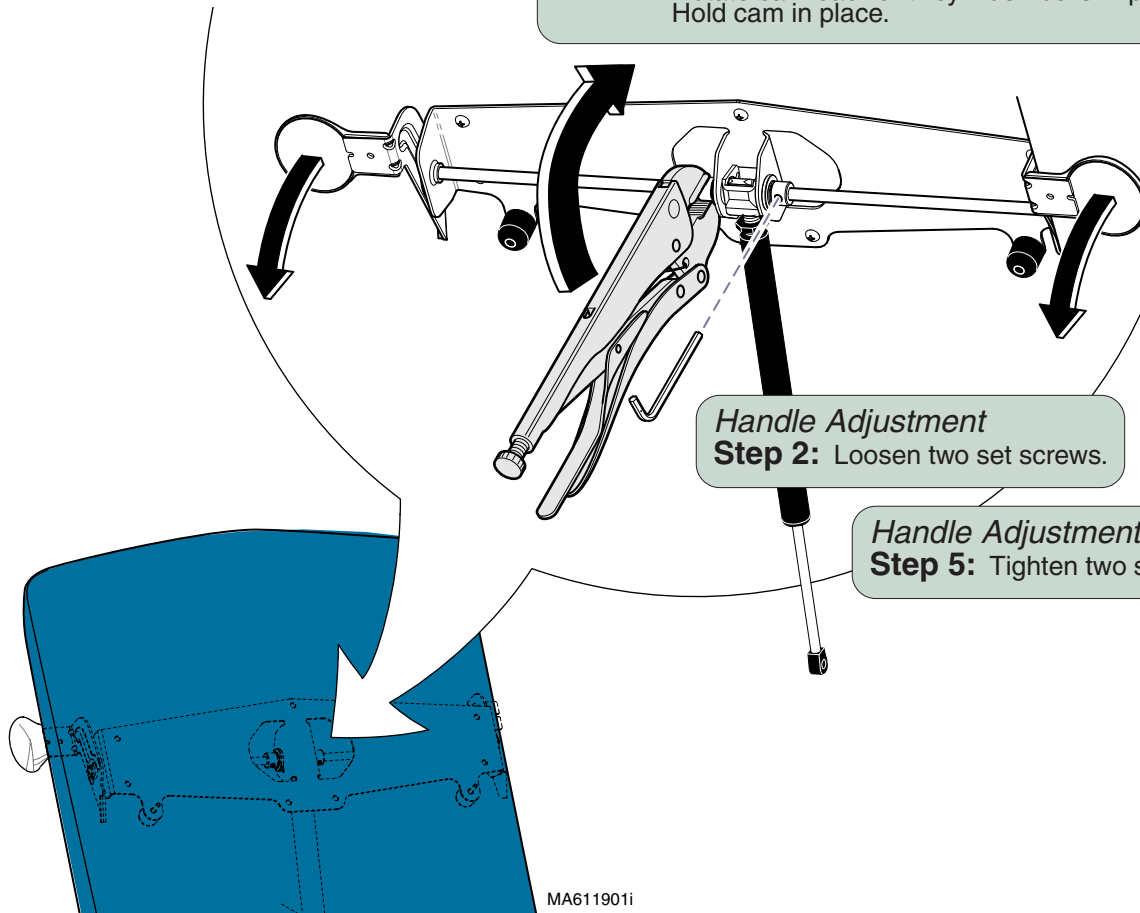

Models:
Serial Numbers:

222 (all)
All

622 (all)
All

**Back Release
Mechanism**

Component Testing & Repair

Back Release Mechanism - continued

Gas Cylinder Replacement & Adjustment

Removal

Step 1: Lower back section all the way down.

Installation

Step 2: Hold cylinder shaft.
Extend shaft 2-3 in.
(Squeeze release handle gently)

Removal

Step 2: Remove clevis pin.

Note: If clevis pin is inaccessible,
refer to: *Top Cover Removal* below.

Installation

Step 3: Install clevis pin.
Perform Adjustment.

Adjustment

Step 2: Tighten jam nut.

Adjustment

Step 1: Screw cylinder in/out one turn.
Check for proper operation.
Repeat as necessary.

Note: If cylinder drifts, screw OUT.
If cylinder does not release, screw IN.

Removal

Step 3: Loosen jam nut.
Unscrew cylinder.

Installation

Step 1: Screw cylinder in until
3-4 threads are exposed.

Top Cover Removal

Step 1: Lower table shrouds. (Refer to Section C)
Remove four screws.
Raise top cover to access clevis pin.

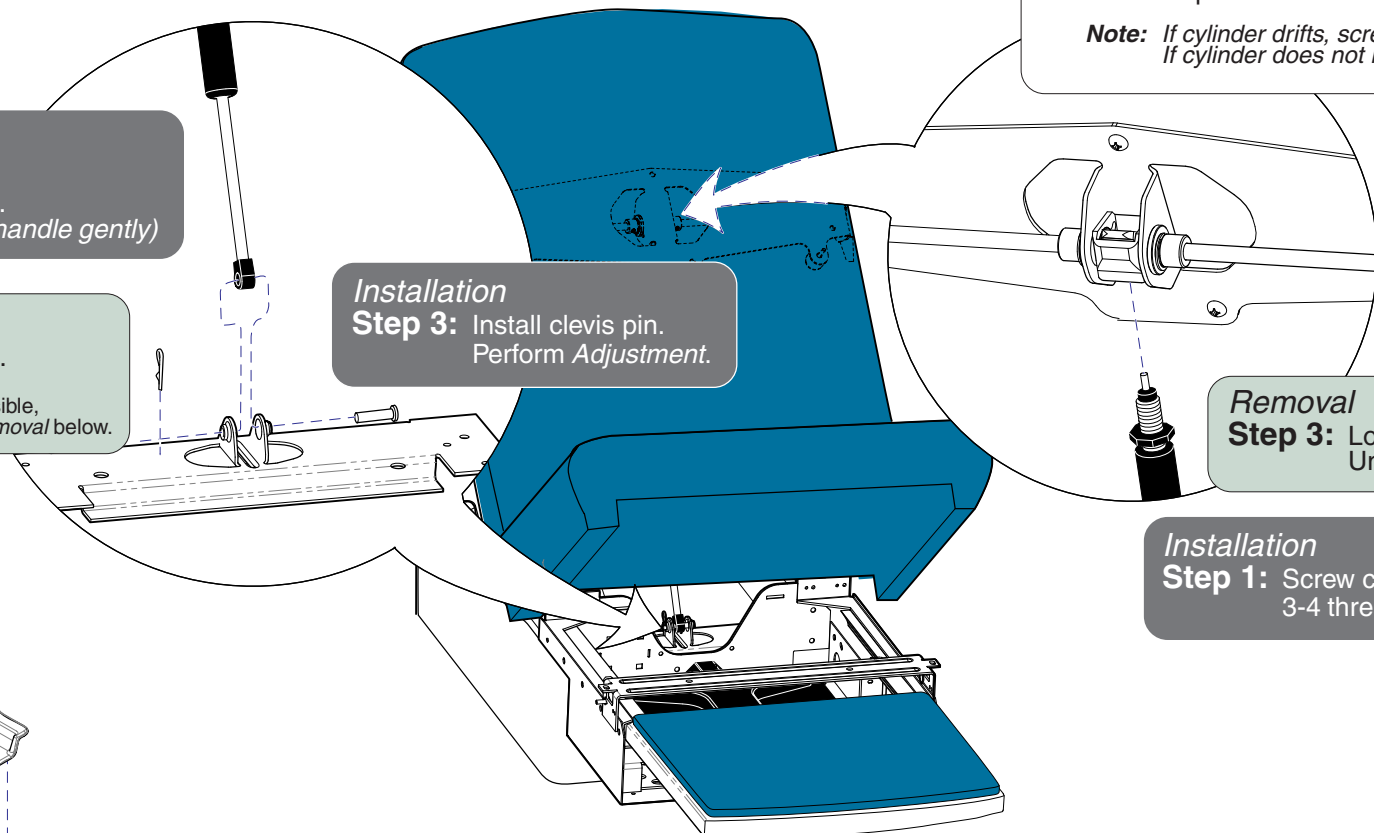
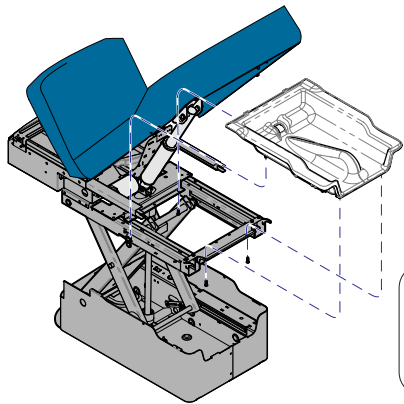

MA607602i

Component Testing & Repair

Main PC Board

This illustration shows the location of the fuses on the Main PC Board. Use the table below to determine the required action.

Problem	Required Action
Base actuator motor does not run.	Check fuses (F1& F2, F3, F4). Perform Base Relay Test
Back actuator motor does not run.	Check fuses (F1& F2, F3, F5). Perform Back Relay Test

- 222 / 622** single function / one relay (*Base Relay*)
Fuses:
 F1 & F2 Primary Fuses (*affect all functions*)
 F3 Base Motor Fuse (*affects Base Up / Down*)
 F4 Transformer Fuse (*affects all functions*)
- 223 / 623** dual function / two relays (*Base Relay & Back Relay*)
Fuses:
 F1 & F2 Primary Fuses (*affect all functions*)
 F3 Base Motor Fuse (*affects Base Up / Down*)
 F4 Transformer Fuse (*affects all functions*)
 F5 Back Motor Fuse (*affects Back Up / Down*)

Main PC Board	Page
Base Relay Test	B-20
Back Relay Test	B-21
Replacement	B-22
Wiring Diagrams	D-1
Part Numbers	
222 / 622	E-22*
223 / 623	E-23
* multiple pages due to model / serial # break	

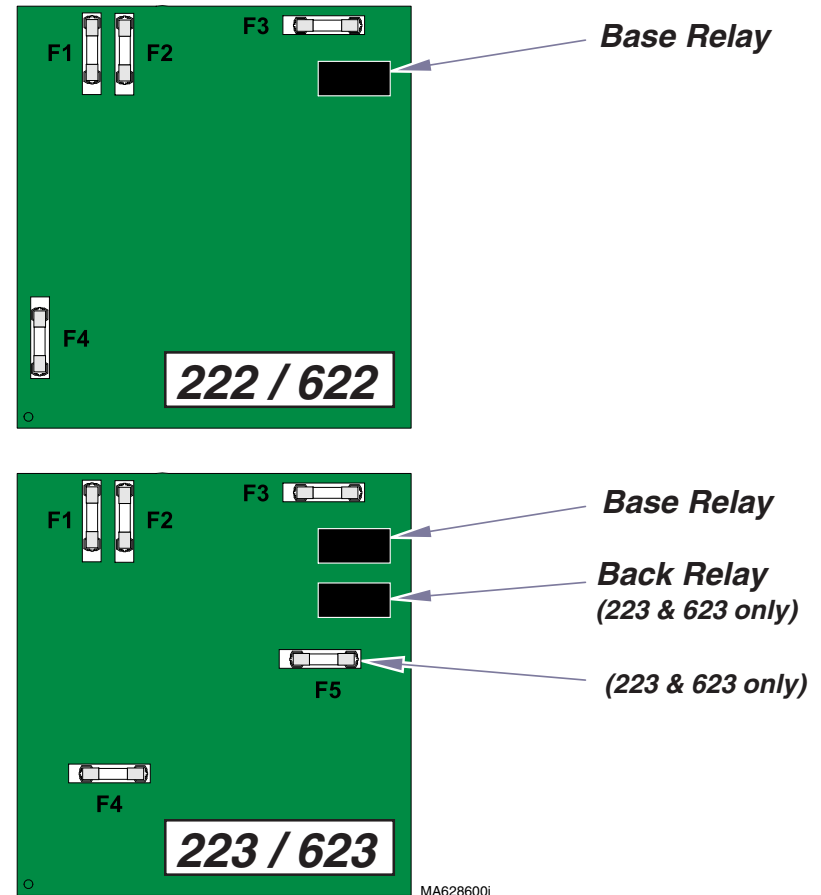

Models:	All
Serial Numbers:	All

Main PC Board

Component Testing & Repair

Main PC Board - continued

Base Relay Test

Base Relay Test
Step 1: Set meter to VDC.



Note: Wires must remain connected to PC Board to perform this test.

Base Relay Test
Step 2: Clip meter test hooks on terminals at J2 and J3.

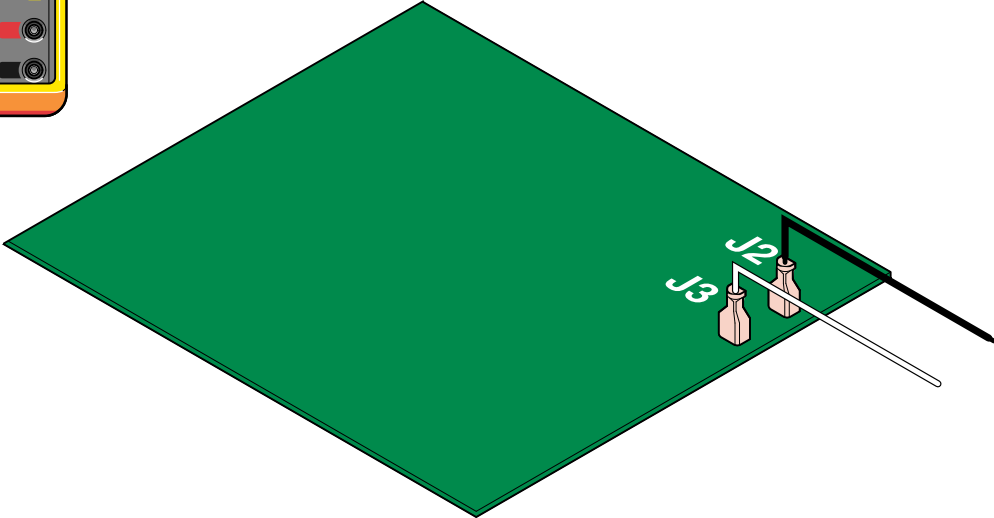

Base Relay Test
Step 3: Activate Base Up / Down function using the foot or hand control.

Meter Reading	Status	Required Action
approx. 48 VDC		PC Board is good. Perform next check.
0 VDC		Replace PC Board.

MA718400i

Component Testing & Repair

Main PC Board - continued

Back Relay Test

Back Relay Test

Step 1: Set meter to VDC.



Note: Wires must remain connected to PC Board to perform this test.

Base Relay Test

Step 2: Clip meter test hooks on terminals at J4 and J5.

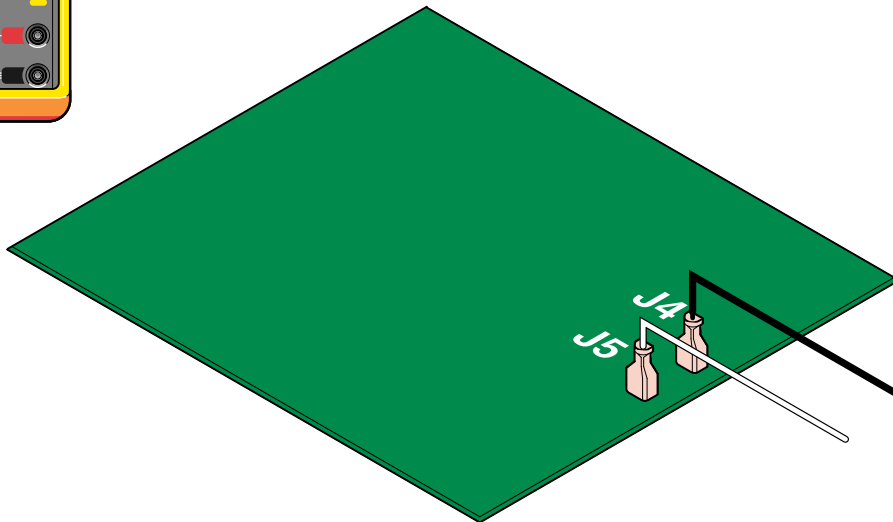

MA718500i

Back Relay Test

Step 3: Activate Back Up / Down function using the foot or hand control.

Meter Reading	Status	Required Action
approx. 48 VDC		PC Board is good. Perform next check.
0 VDC		Replace PC Board.

Models:
Serial Numbers:

223 (all)
All

623 (all)
All

Main PC Board

B-21

Component Testing & Repair

Main PC Board - continued

Replacement

Removal (see Access Procedures)
Step 1: Remove outer shrouds.
Note: The inner and middle shrouds will drop down. It is not necessary to remove them.

Installation (see Access Procedures)
Step 4: Replace outer shrouds.

Caution
 Unplug power cord before removing PC Board cover.

Removal
Step 2: Remove PC Board cover.

Installation
Step 3: Replace PC Board cover.

Removal
Step 3: Disconnect ground wire.
 Tag and disconnect wiring from PC Board.

Installation
Step 2: Connect ground wire.
 Connect all wiring.

Removal
Step 4: Remove PC Board.
Tip: Push latches back, then lift off of mounting studs.

Note: Boards manufactured after 6/05 will beep for approximately three seconds when table is first plugged in.

Access Procedures	Page
Table Shrouds	
Removal / Installation	C-2
Manually Raising / Lowering Table	C-5

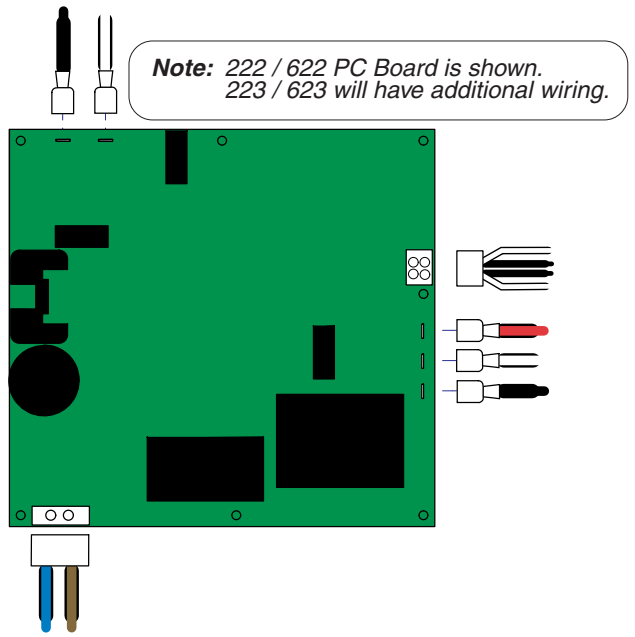
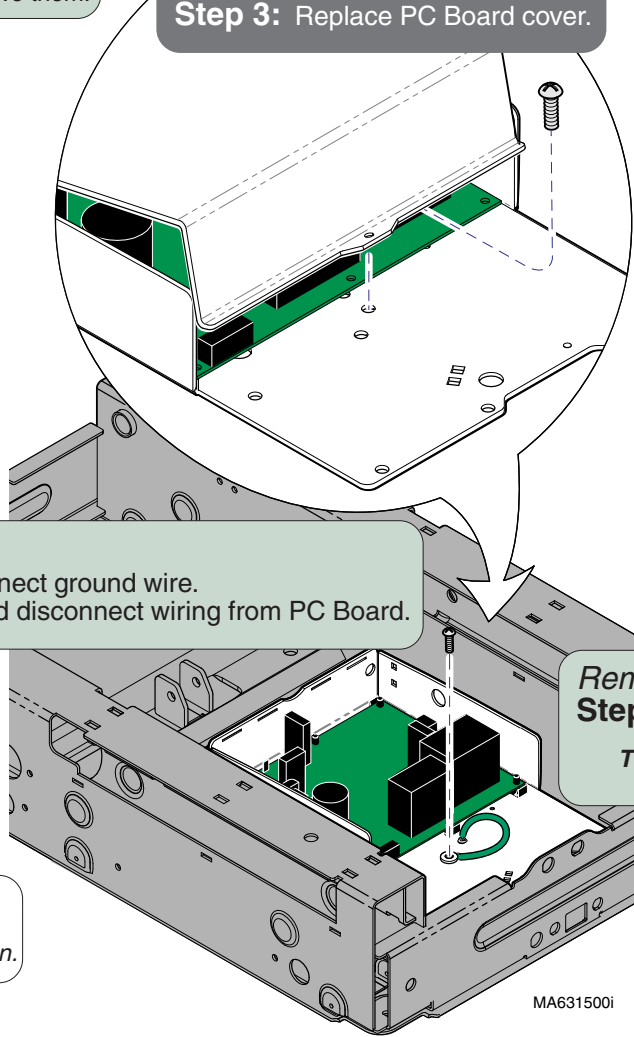

Main PC Board

Models: All
Serial Numbers: All

Drawer Heater System

Use the table below to determine the required action.
 [This table applies to all models (222 / 223 / 622 / 623)]

Problem	Required Action
Drawer heater does not warm up. Heater switch does <u>not</u> illuminate	Perform Heater Switch Test
Drawer heater does not warm up. Heater switch illuminates.	Perform Heater Plate Test
Drawer heater - OK Heater switch does <u>not</u> illuminate	Replace heater switch.

Drawer Heater System	Page
Distribution Board Fuses	B-2
Heater Switch Test:	
222 / 223	B-23
622 / 623	B-24
Switch Replacement 622 / 623	B-25
Heater Plate Test:	
222 / 223	B-26
622 / 623	B-27
Heater Plate Replacement	B-28
Wiring Diagrams	D-1
Part Numbers	E-30*

* multiple pages due to model / serial # break

Heater Switch Test - 222 / 223

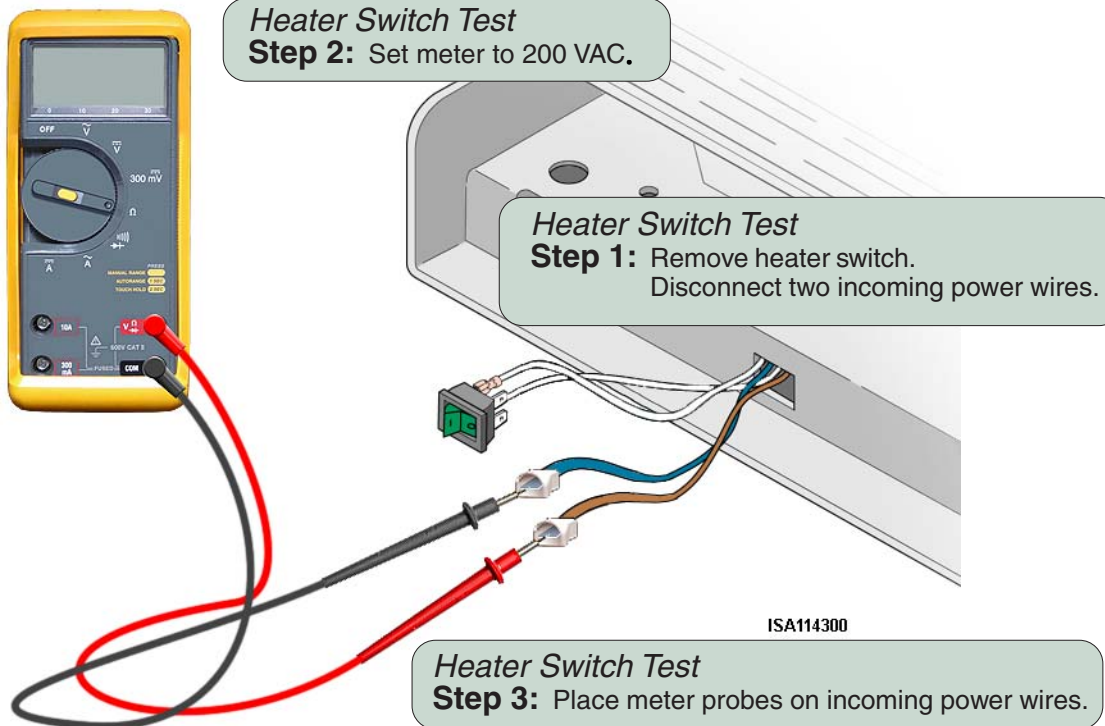

Meter Reading	Status	Required Action
approx. 115 VAC		Replace switch.
0 VAC		Switch OK. Check connections & fuses

Models:	222	223
Serial Numbers:	All	All

Component Testing & Repair

Drawer Heater System - continued

Heater Switch Test - 622 / 623

Access Procedures	Page
Chair Arm Brace Removal	C-8

Caution
Unplug power cord before removing stirrup guide.

Removal
Step 1: Remove stirrup guide.
Note: If necessary, remove chair arm brace (see Access Procedures).

Installation
Step 2: Replace stirrup guide.

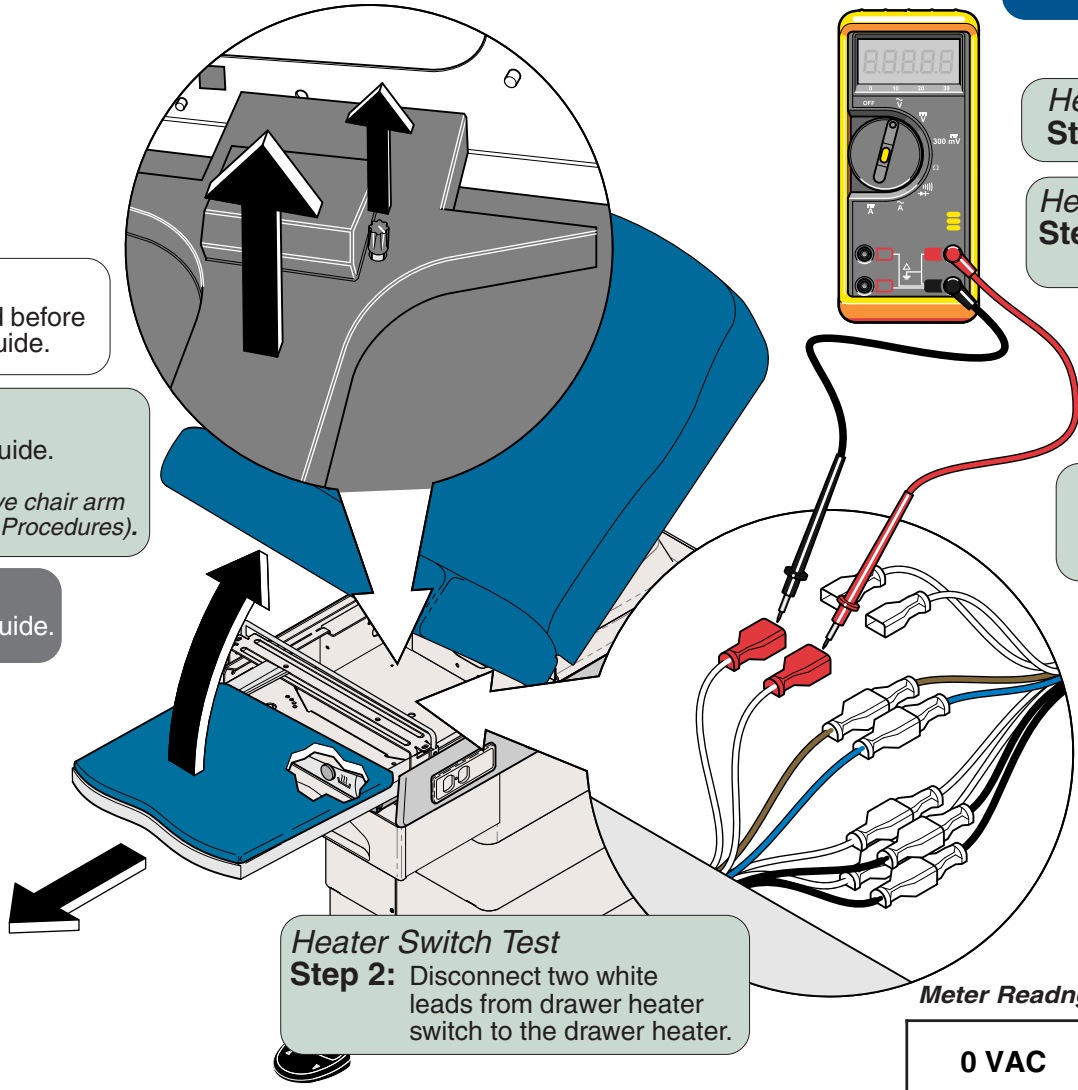

Heater Switch Test
Step 2: Disconnect two white leads from drawer heater switch to the drawer heater.

Heater Switch Test
Step 3: Set meter to 200 VAC.

Heater Switch Test
Step 4: Place meter probes on two white leads from switch.

Heater Switch Test
Step 5: Plug in power cord, then depress switch to ON.

Caution
Unplug power cord before re-connecting electrical leads.

Installation
Step 1: Re-connect electrical leads.

Meter Reading	Status	Required Action
0 VAC		Replace switch.
approx. 115 VAC		Switch OK. Check Heater Plate.

Component Testing & Repair

Drawer Heater System - continued

[Access Procedures](#)

[Page](#)

Chair Arm Brace Removal C-8

Heater Switch Replacement - 622 / 623

(This procedure also applies to the upholstery heater switch)



Caution
Unplug power cord before removing stirrup guide.

Removal
Step 1: Remove stirrup guide.

Note: If necessary, remove chair arm brace (see Access Procedures).

Installation
Step 4: Replace stirrup guide.

Removal
Step 2: Tag, then disconnect wires from faulty switch.

Installation
Step 3: Connect switch electrical wires.

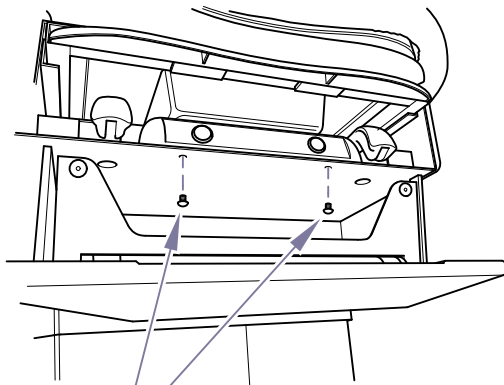

Removal
Step 3: Remove switch housing.

Installation
Step 2: Install switch housing.

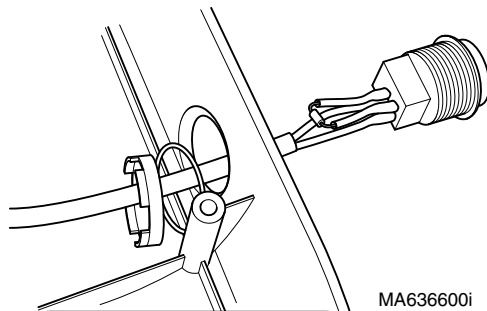

Removal
Step 4: Remove switch assembly.

Installation
Step 1: Install switch assembly.

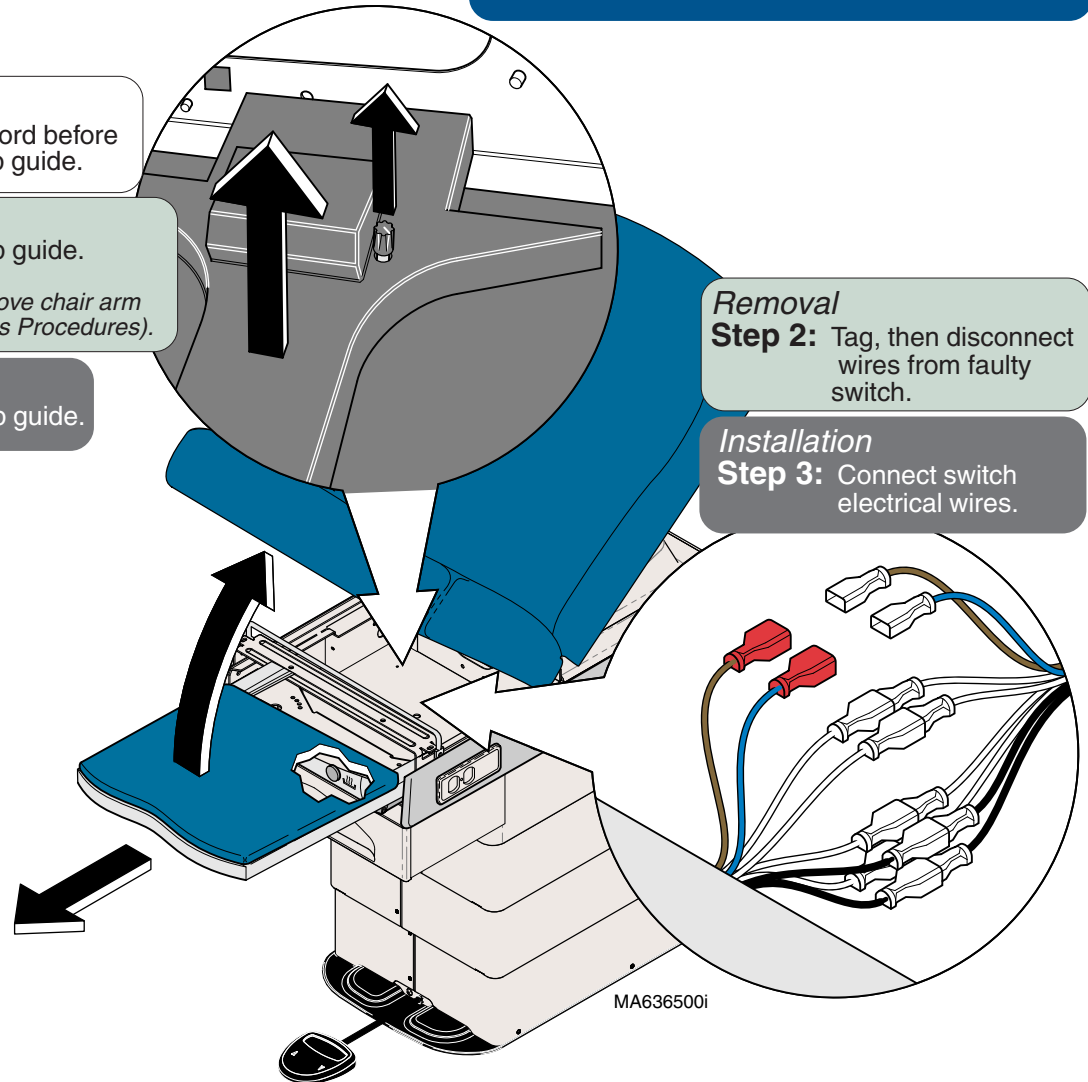

Models:
Serial Numbers:

622
All

623
All

Drawer Heater System

Component Testing & Repair

Drawer Heater System - continued

Heater Plate Test -222 / 223

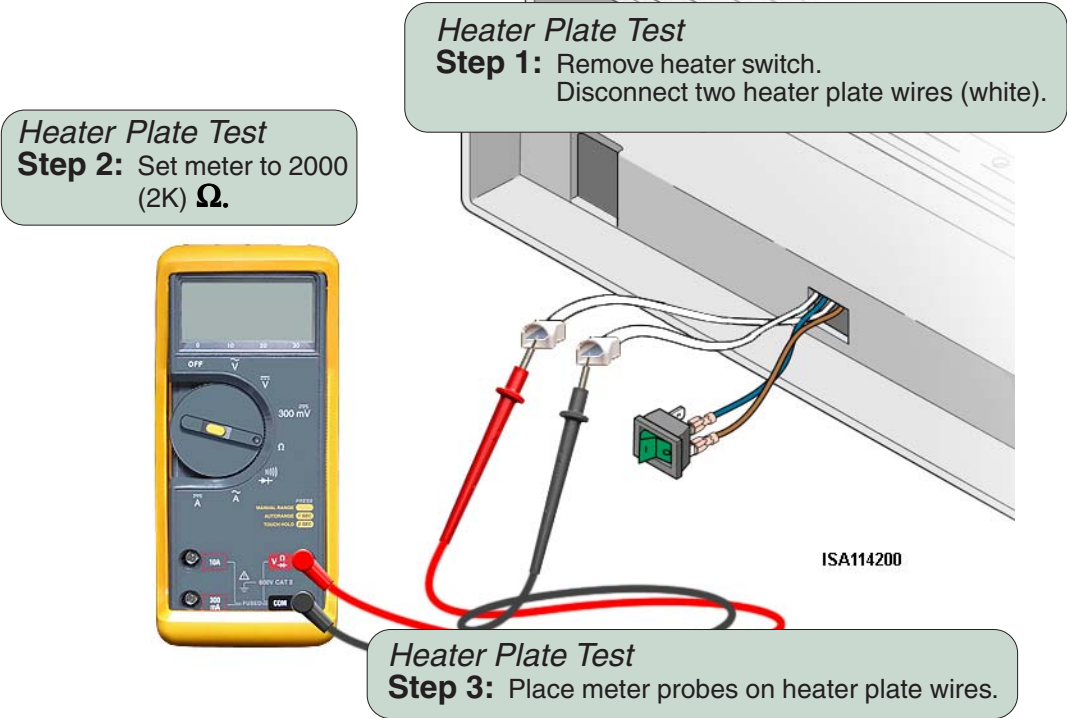

Meter Reading	Status	Required Action
approx. 360 Ω		Heater plate is good.
0 Ω		Replace heater plate.

Component Testing & Repair

Drawer Heater System - continued

Heater Plate Test -622 / 623

Access Procedures	Page
Chair Arm Brace Removal	C-8

Caution
Unplug power cord before removing stirrup guide.

Removal
Step 1: Remove stirrup guide.
Note: If necessary, remove chair arm brace (see Access Procedures).

Installation
Step 2: Replace stirrup guide.

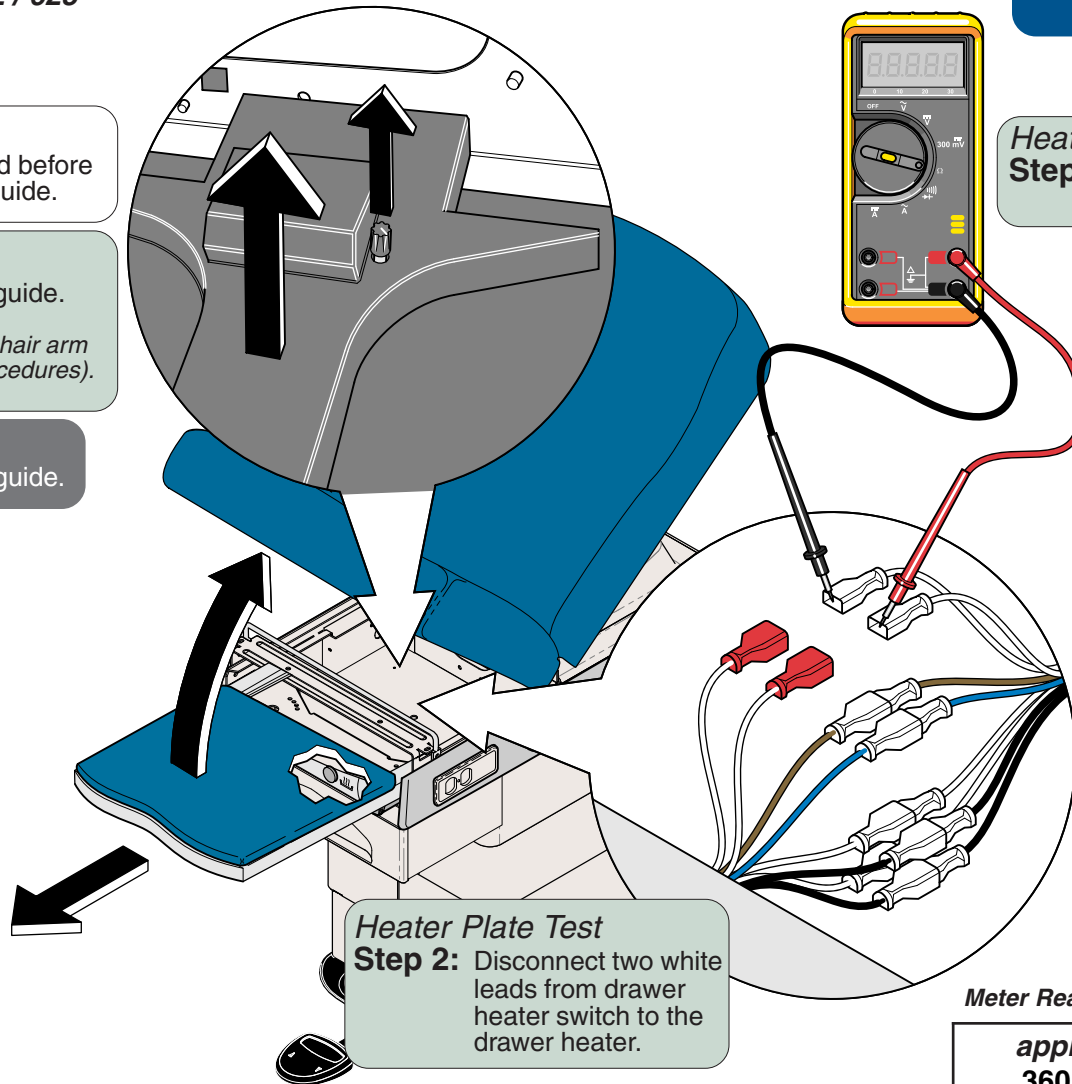

Heater Plate Test
Step 3: Set meter to 2000 (2K) Ω .

Heater Plate Test
Step 4: Place meter probes on terminals of heater plate wires.

Installation
Step 1: Re-connect electrical leads.

Heater Plate Test
Step 2: Disconnect two white leads from drawer heater switch to the drawer heater.

Meter Reading	Status	Required Action
approx. 360 Ω		Heater plate is good. Perform next check.
0 Ω		Replace heater plate.

Models:	622	623
Serial Numbers:	All	All

Drawer Heater System

Component Testing & Repair

Drawer Heater System - continued

Heater Plate Replacement

Removal

Step 1: Remove screw(s) from drawer slides.

Installation

Step 3: Install screw.

Installation

Step 3: Install drawer.

Removal

Step 2: Push LH slide lever UP and RH lever DOWN. Remove drawer.

Note: Slide levers are clear plastic.

Attention

If there is not a wire connection here, you must lower table shrouds and remove the top cover in order to disconnect / route heater plate wires.

Installation

Step 2: Route heater plate wires behind slide. Connect wires.

Removal

Step 3: Disconnect heater plate wires.

Removal

Step 4: Remove heater plate.

Installation

Step 1: Install heater plate.

MA633800i

Upholstery Heater System

Use the table below to determine the required action.

Problem	Required Action
Upholstery heater does not warm up. Heater switch does <u>not</u> illuminate	Perform Upholstery PC Board Test
Upholstery heater does not warm up. Heater switch illuminates.	Perform Upholstery Heater Test
Upholstery heater - OK Heater switch does <u>not</u> illuminate	Replace heater switch.

Upholstery Heater System Page

Upholstery Heater PC Board Test:	
Output Voltage Test	B-29
Supply Voltage Test	B-30
PC Board Replacement	B-31
Upholstery Heater Test	B-32
Upholstery Heater Switch Test	B-33
Wiring Diagrams	D-1
Part Numbers	E-32

Upholstery Heater PC Board Test

(Output Voltage Test)

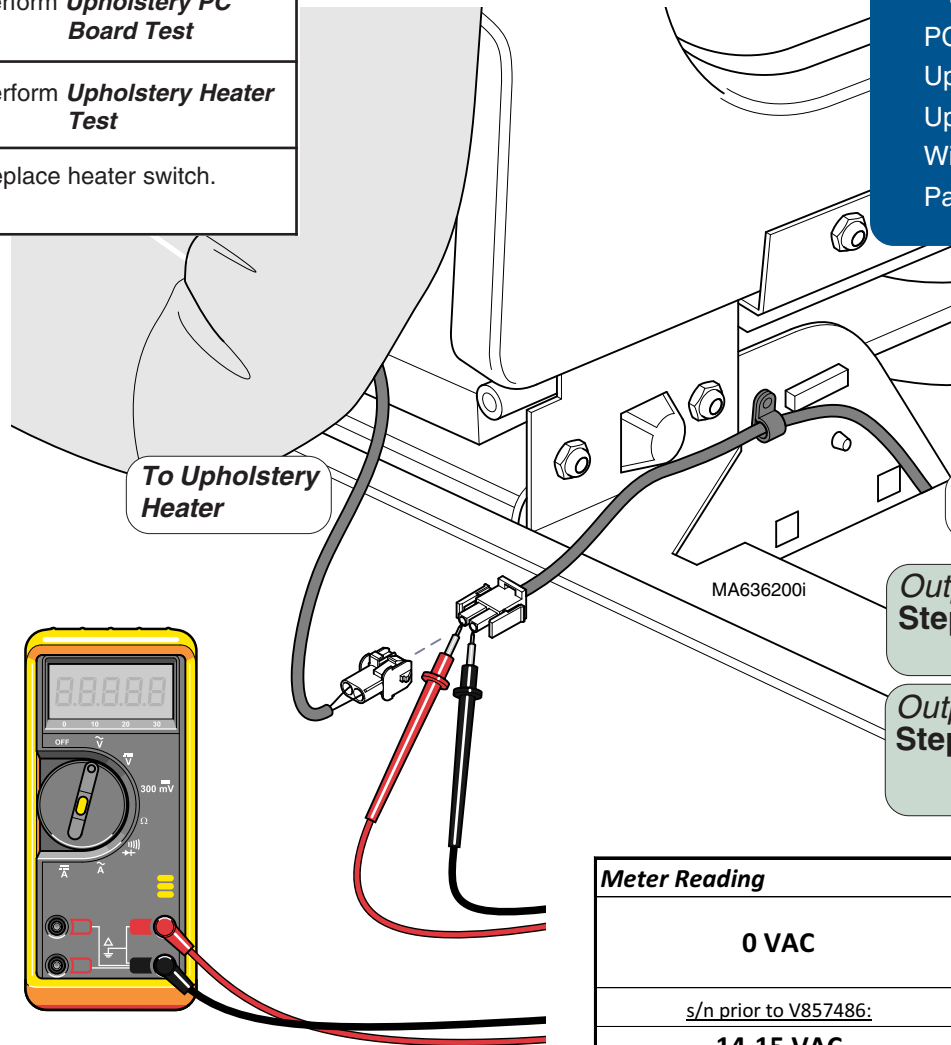

Output Voltage Test
Step 2: Set meter to 20 VAC.

Output Voltage Test
Step 4: Press Upholstery (Green) Heater switch ON.

Output Voltage Test
Step 1: Disconnect leads to upholstery heater.

Output Voltage Test
Step 3: Place meter probes on leads from upholstery heater PC Board.

Meter Reading	Status	Required Action
0 VAC		Check supply voltage to heater PC board
<u>s/n prior to V857486:</u> 14-15 VAC		Check upholstery heater.
<u>s/n V857487 to present:</u> 7-8 VAC		

Models:	622	623
Serial Numbers:	All	All

Upholstery Heater System

Component Testing & Repair

Upholstery Heater System - continued

Upholstery Heater PCB Test - continued

(Supply Voltage Test)



Caution

Unplug power cord before removing stirrup guide.

Supply Voltage Test

Step 1: Remove stirrup guide.

Note: If necessary, remove chair arm brace (see Access Procedures).

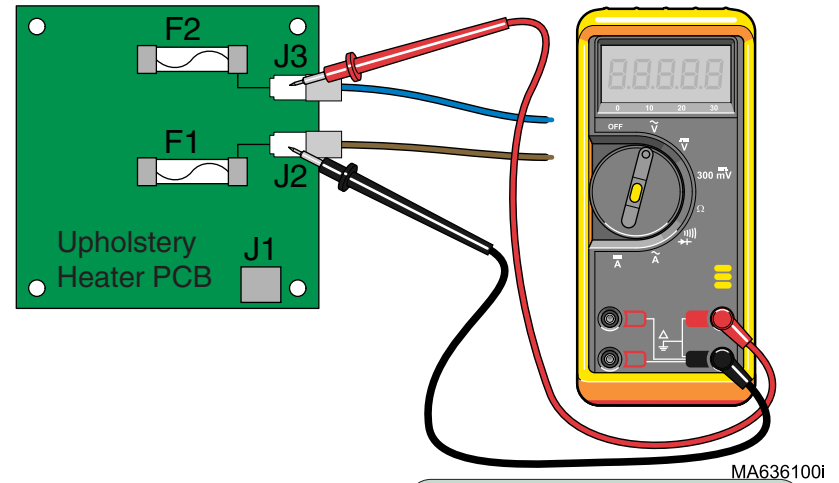
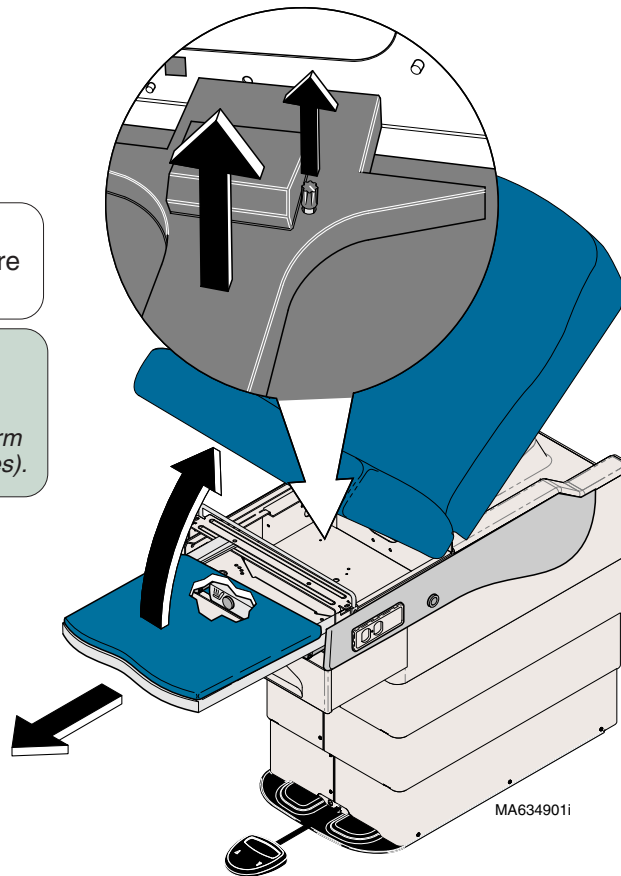

Supply Voltage Test
Step 2: Set meter to 200 VAC.

Supply Voltage Test
Step 3: Place meter probes on J2 & J3 of Upholstery Heater PCB and plug table into outlet.

Meter Reading	Status	Required Action
0 VAC		Check incoming power source to table.
115 VAC		Check connections & F1 / F2 fuses on PCB.

Component Testing & Repair

Upholstery Heater System - continued

Upholstery Heater PC Board Replacement



Caution

Unplug power cord before removing PC Board cover.

Upholstery Heater PC Board Removal
Step 2: Depress release on standoffs and remove PC Board.

Installation
Step 1: Replace PC Board.

Upholstery Heater PC Board Removal
Step 1: Tag, then disconnect leads to PC board.

Installation
Step 2: Re-connect electrical leads.

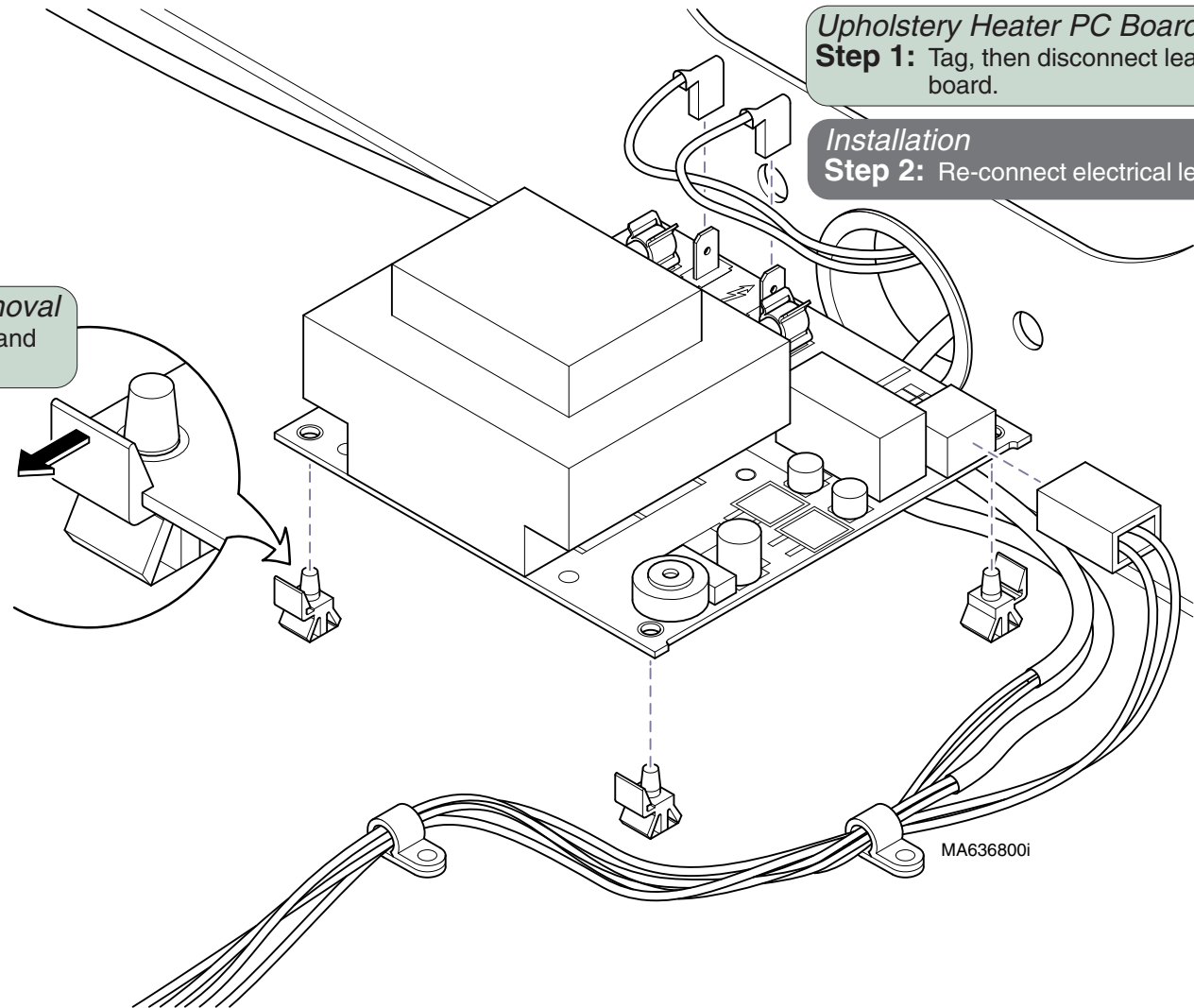

Models:
Serial Numbers:

622
All

623
All

**Upholstery Heater
System**

B-31

Component Testing & Repair

Upholstery Heater System - continued

Upholstery Heater Test

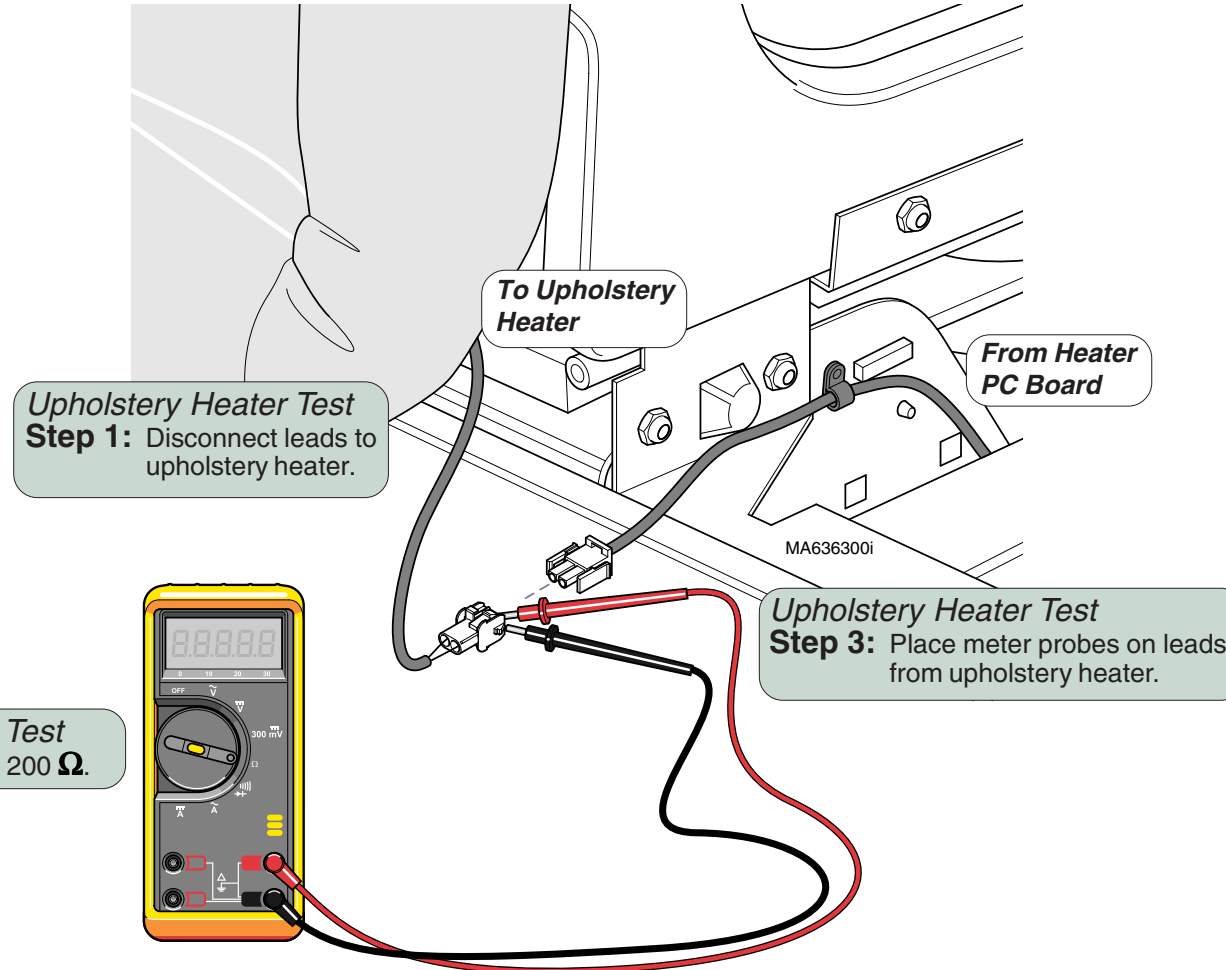

Meter Reading	Status	Required Action
0 Ω		Replace Upholstery
3 - 4 Ω		Check Upholstery Heater Switch.

Component Testing & Repair

Upholstery Heater System - continued

Upholstery Heater Switch Test

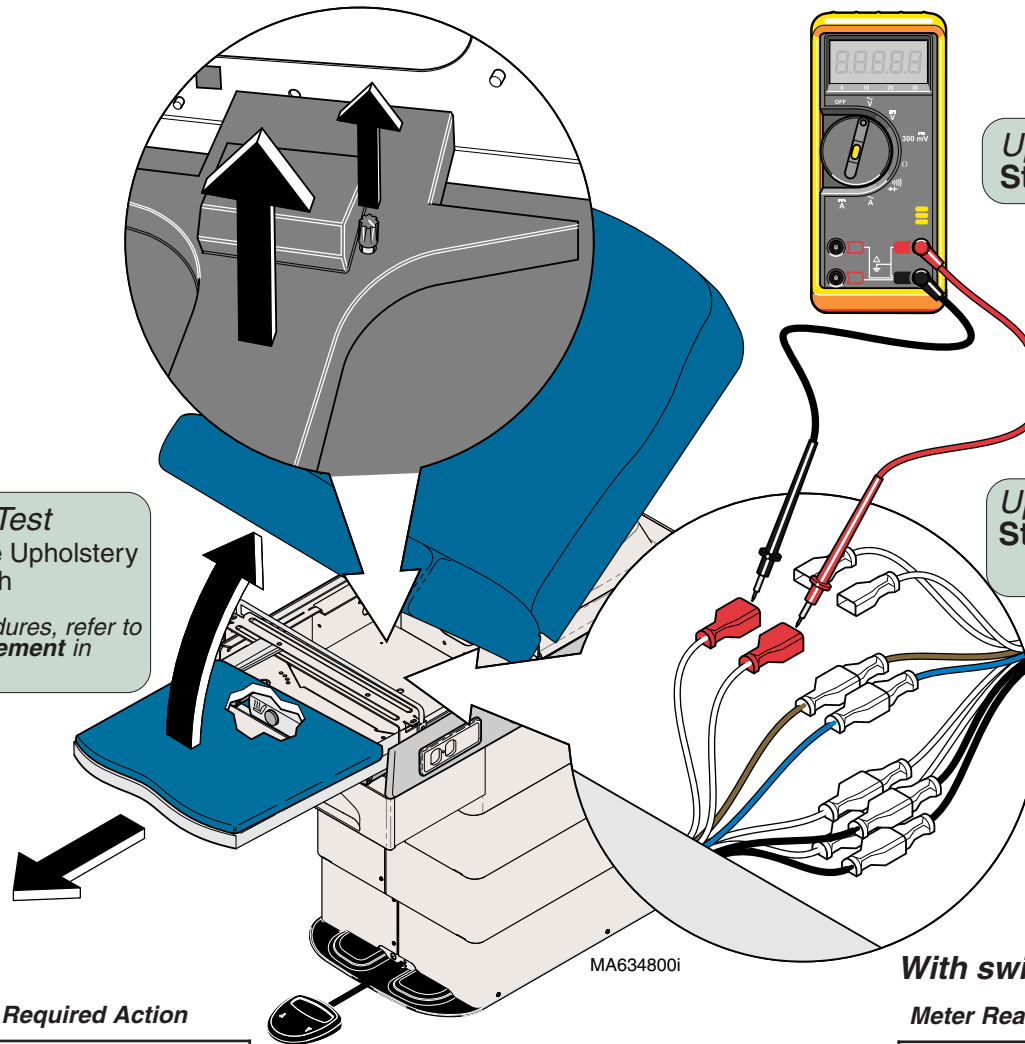

Upholstery Heater Switch Test
Step 1: Set meter to 200 Ω .

Upholstery Heater Switch Test
Step 2: Disconnect Black leads from Switch and insert meter probes.

Upholstery Heater Switch Test
Step 3: Depress & hold in the Upholstery Heater (Green) Switch
Note: For replacement procedures, refer to **Heater Switch Replacement** in **Drawer Heater System**

With switch 'tripped'...

Meter Reading	Status	Required Action
Any resistance reading		Switch is good. Perform next check.
OL		Replace switch

With switch 'untripped'...

Meter Reading	Status	Required Action
Any resistance reading		Replace switch.
OL		Switch is good. Perform next check.

Models:	622	623
Serial Numbers:	All	All

Upholstery Heater System

Access Procedures

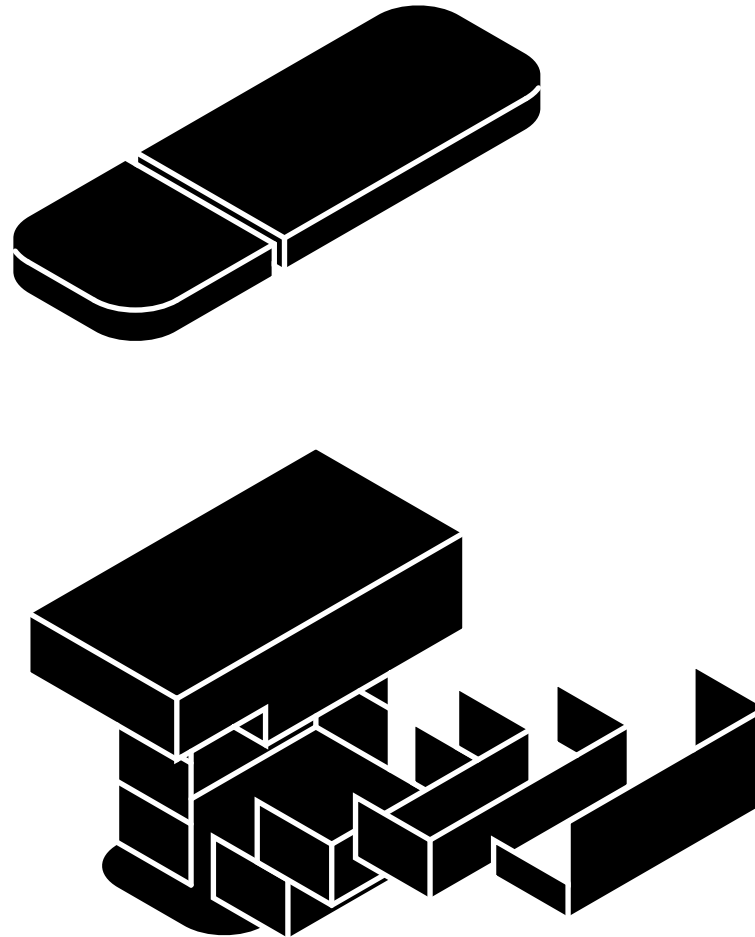

<u>Procedure</u>	<u>Page</u>
Table Shrouds (<i>Remove / Install</i>)	C-2
Manually Raising / Lowering Table	C-5
Upholstered Top (<i>Remove / Install</i>):	
<i>Ritter models</i>	C-6*
<i>Midmark models</i>	C-7*
Chair Arm / Brace Removal	C-8
Top Cover (<i>Remove Install</i>)	C-9
Back Limit Switch Access	C-9

Component Testing & Repair

Table Shrouds

Removal / Installation

Note
Remove all accessories (ex. chair arms) before performing this procedure.

Refer To: **Page**
Exploded Views / Part Numbers:
Table Shrouds (Ritter models) E-13*
Table Shrouds (Midmark models) E-14*
** multiple pages due to model / serial # break*

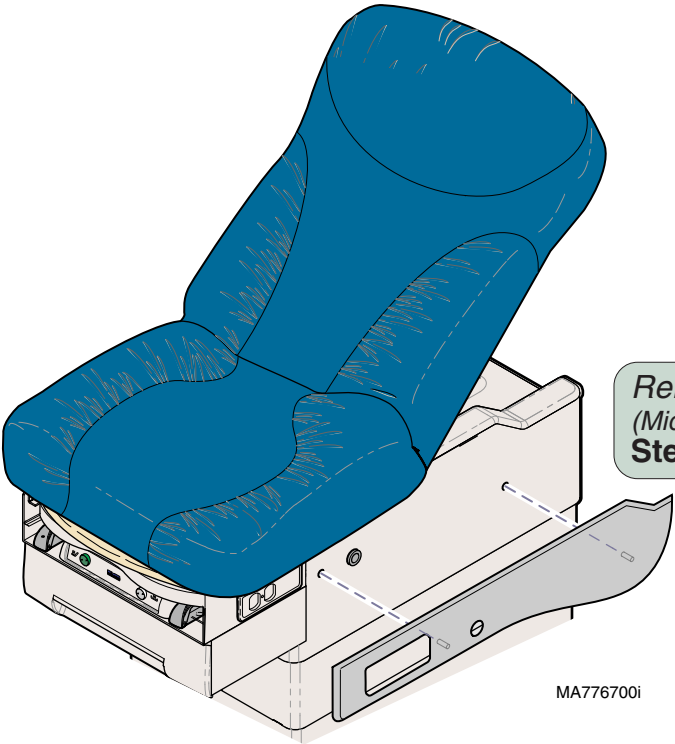

Removal
(Midmark models only)
Step 1: Remove magnetic cladding.

Removal
Step 2: Remove screw(s) from drawer slides.
Note: Tables w/o drawer heater do not have screws.

Installation
Step 7: Install screw(s) in drawer slides.

Installation
Step 6: Install drawer.

Removal
Step 3: Push LH slide lever UP and RH lever DOWN. Remove drawer.
Note: Slide levers are clear plastic.

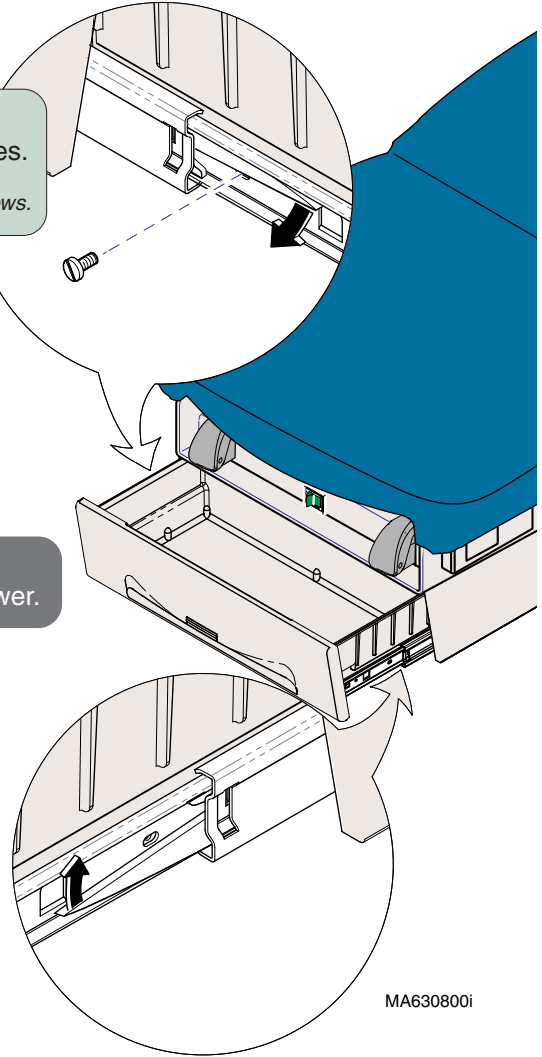

Component Testing & Repair

Table Shrouds - continued

Removal / Installation

Removal

Step 4: Lower table to lowest height.
Disconnect table power cord.

Removal

Step 5: Lift seat section.
Remove two "inside" screws.

Note: If necessary, move receptacle cover for better access to LH screw.

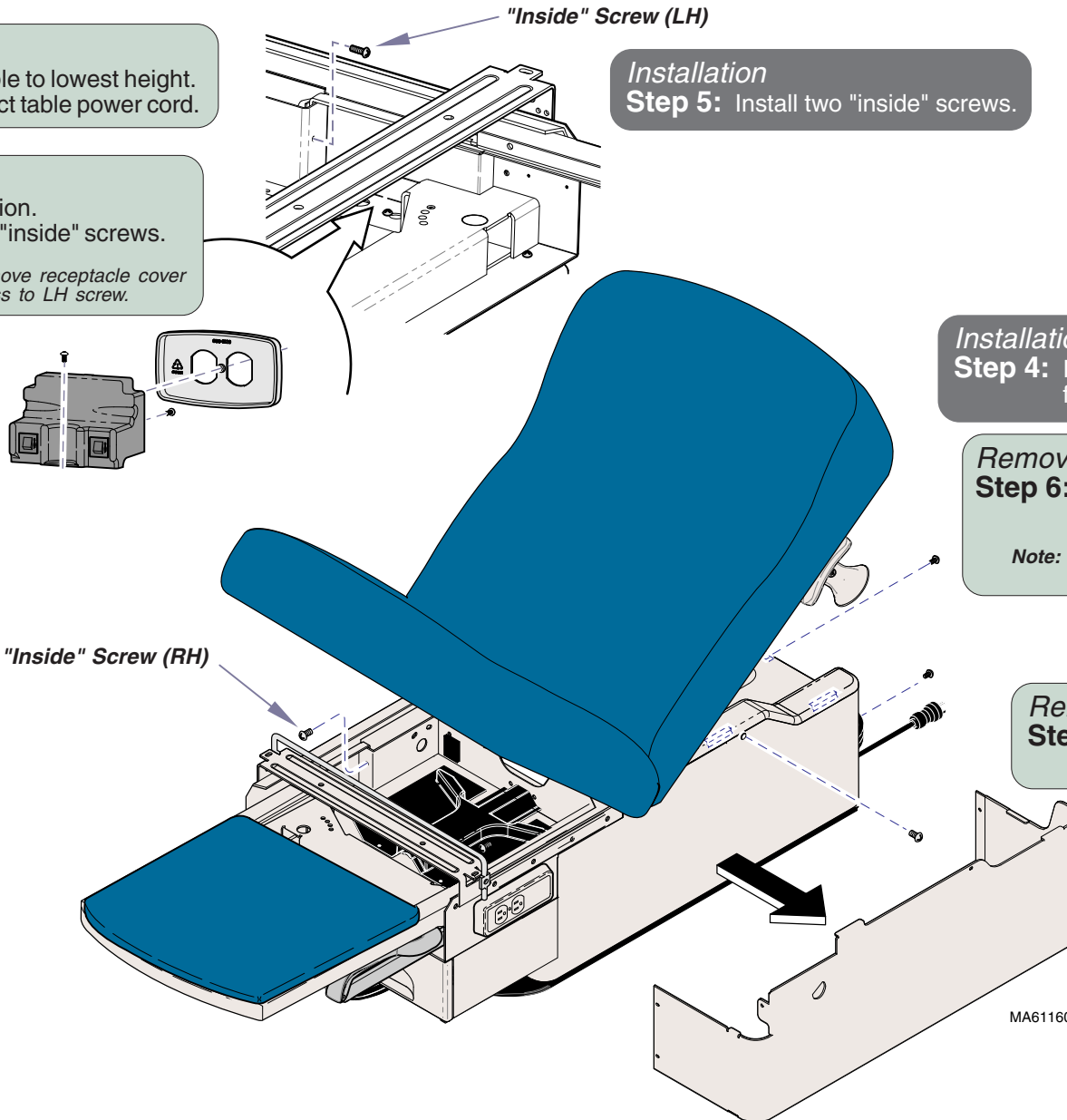

Installation

Step 5: Install two "inside" screws.

Installation

Step 4: Install screws at head-end & foot-end of outer shrouds.

Removal

Step 6: Remove screws from head-end & foot-end of outer shrouds.

Note: Lower the drawer front to access foot-end screws.

Removal

Step 7: Remove side screw & outer shroud.
Repeat for other side.

Installation

Step 3: Position outer shroud.
Install side screw.
Repeat on opposite side.

Models:
Serial Numbers:

All
All

Table Shrouds

Component Testing & Repair

Table Shrouds - continued

Removal / Installation

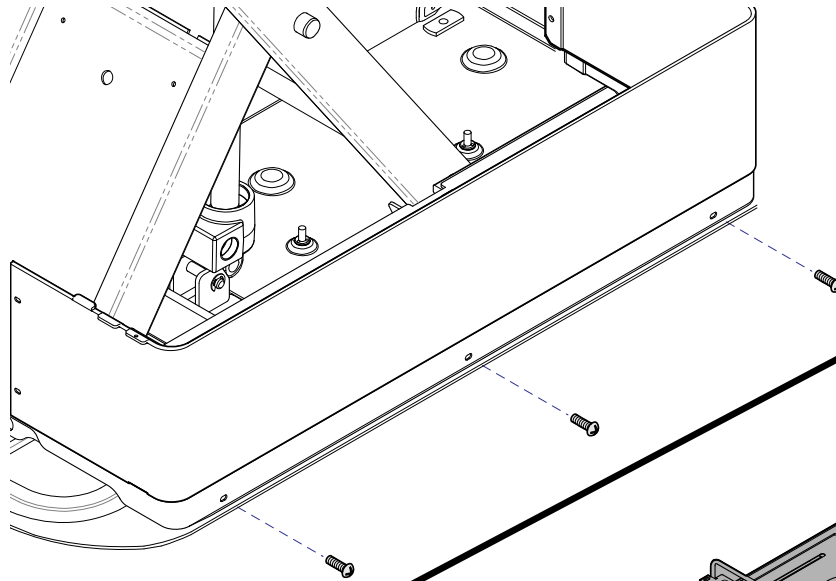

Installation

Step 1: Install six screws securing bottom of inner shrouds.

Removal

Step 8: Remove six screws securing bottom of inner shrouds.

Note: The shrouds on older 222 models do not have the offset guides shown here. On these models, align tabs (*not shown*) so that they engage each other.

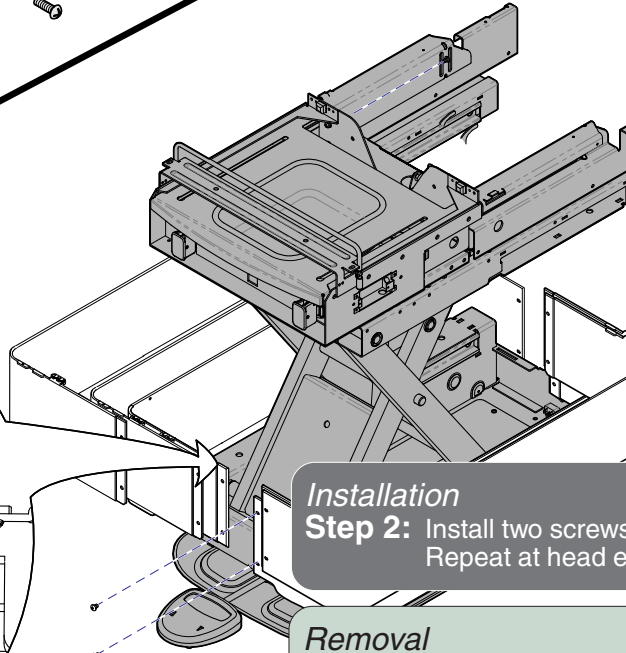
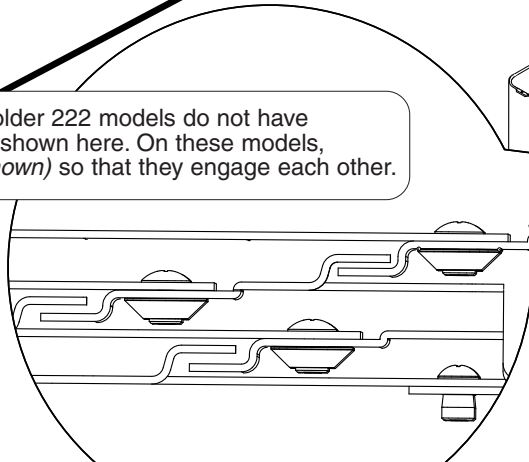

Installation

Step 2: Install two screws securing each set of shrouds. Repeat at head end of table.

Removal

Step 9: Remove two screws securing each set of shrouds. Repeat at head end of table.

Note: On older 222 models, there is a wire connecting the shrouds. This must remain in place to ensure proper grounding.

Manually Raising / Lowering Table

Refer To:

Page

Exploded Views / Part Numbers:

Ritter Base Components E-19*

Midmark Base Components E-20*

Base Actuator E-21

* multiple pages due to model / serial # break

Step 1: Remove table shrouds.
(Access Procedures)

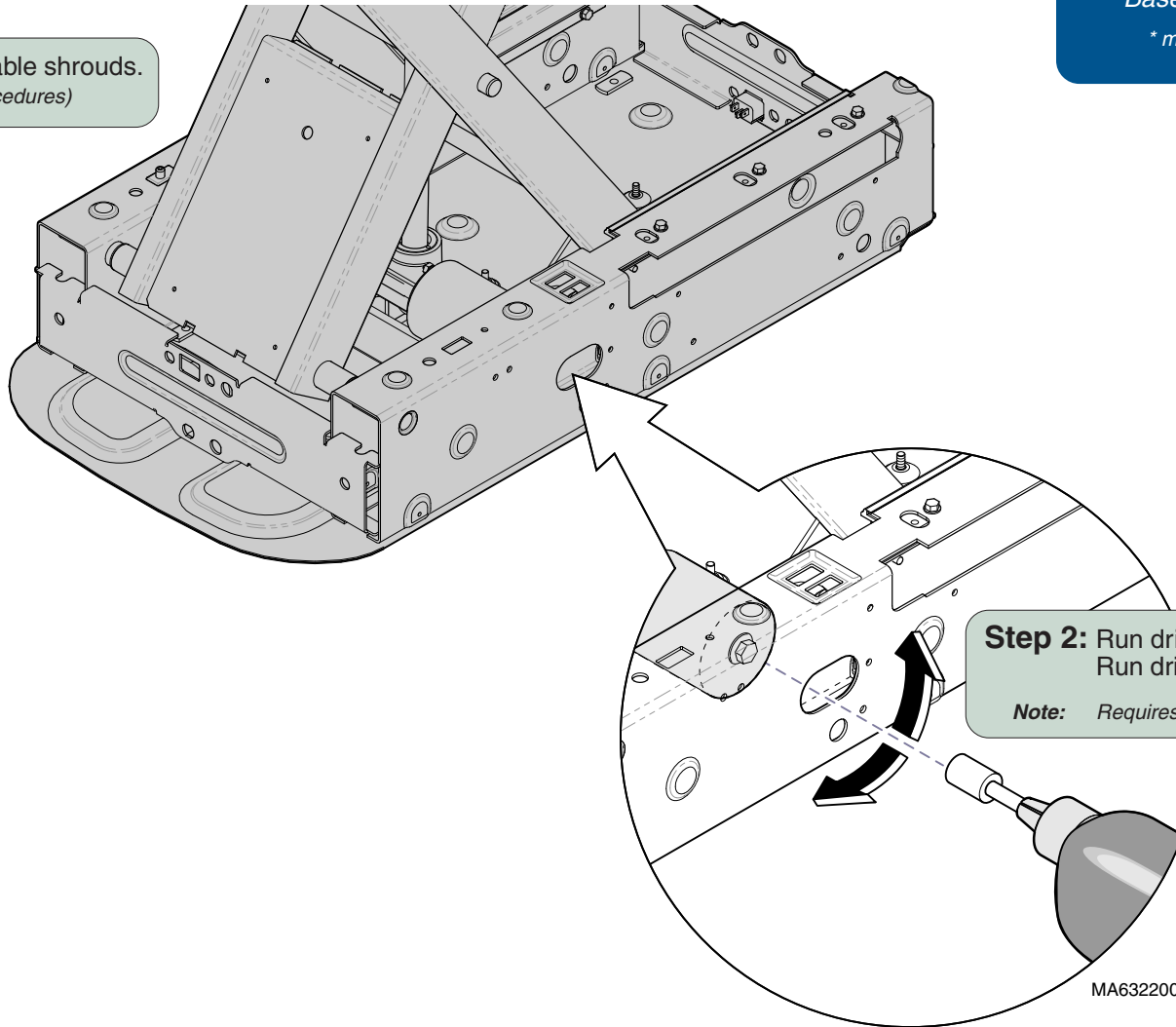

Step 2: Run drill in reverse to raise table.
Run drill forward to lower table.

Note: Requires 5/16" socket w/ extension.

Models:
Serial Numbers:

All
All

Manually
Raising / Lowering

Component Testing & Repair

Upholstered Top (Ritter models)

Removal / Installation
(Soft Touch Top shown)

Attention
Seamless / Styled tops are one piece.
The replacment procedure is similar.

Caution
Hold back section in place
when performing steps 1 & 2.

Refer To:	Page
Exploded Views / Part Numbers:	
Upholstery - Ritter :	
Soft Touch	E-6
Seamless	E-7

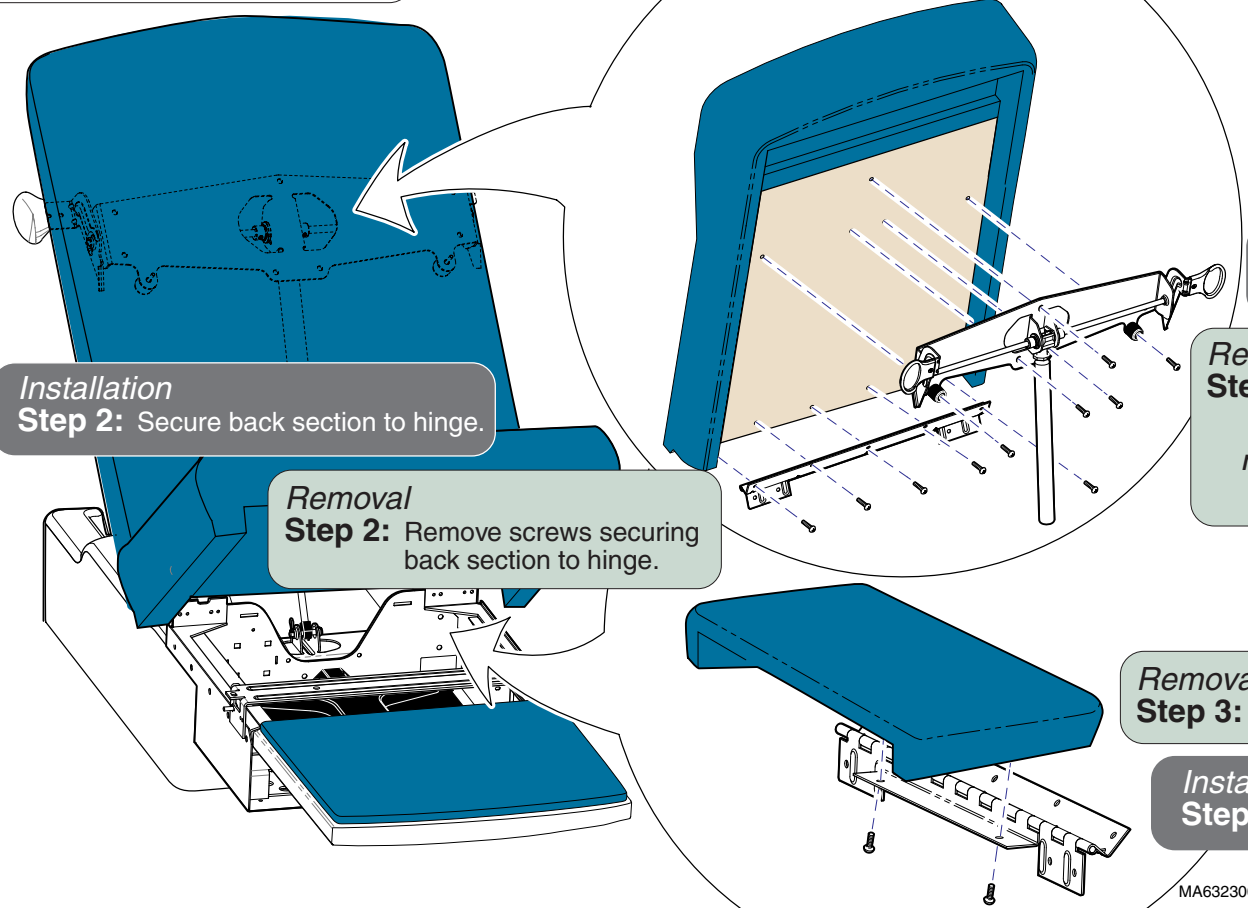

Installation
Step 2: Secure back section to hinge.

Removal
Step 2: Remove screws securing back section to hinge.

Installation
Step 3: Secure back release bracket.

Removal
Step 1: Remove screws securing back release bracket.
Note: The manual back model is shown. The procedure for power back models is similar.

Removal
Step 3: Remove seat section.

Installation
Step 1: Secure seat section.

Models:	222 (-001 thru -014)	223 (-001 thru -014)
Serial Numbers:	All	All

Component Testing & Repair

Upholstered Top (Ritter models)

Removal / Installation

(Soft Touch Top shown)

Installation

Step 1: Position upholstered top & footrest pad on table.

Note: Be sure locking knobs align with holes in back / seat mounting plates.

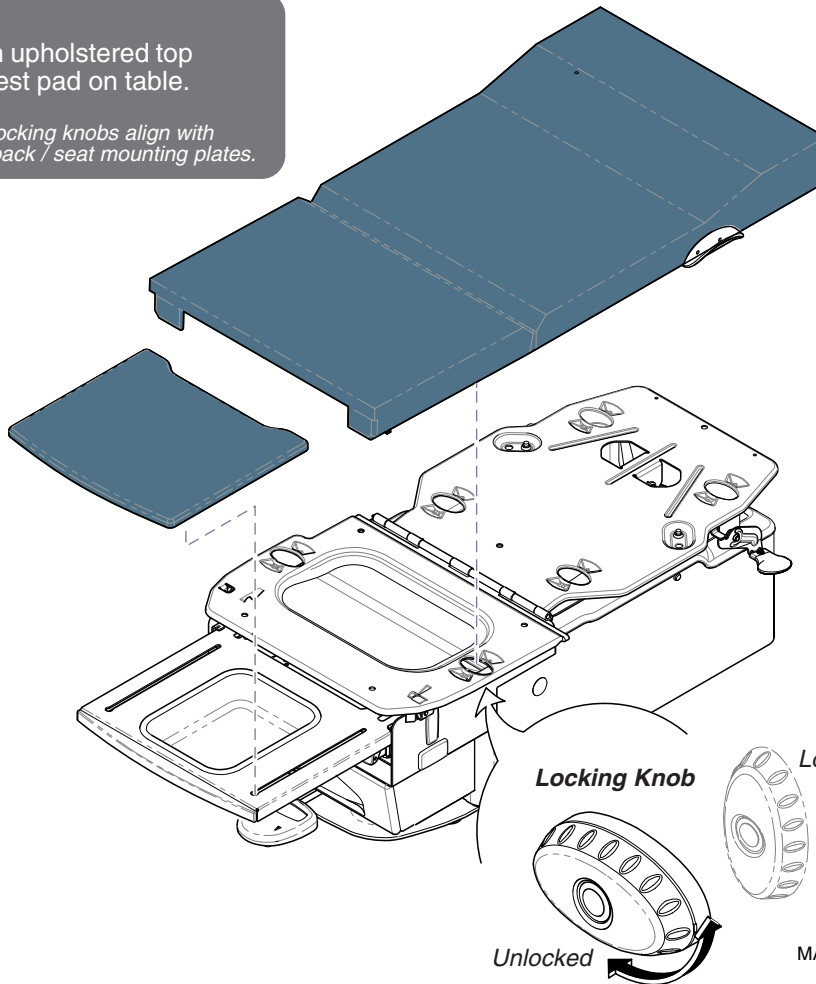

Refer To:

Page

Exploded Views / Part Numbers:

Upholstery - Ritter :

Soft Touch E-6.1

Seamless E-7.1

Removal

Step 2: Remove upholstered top & footrest pad.

Removal

Step 1: Rotate all locking knobs to unlocked position.

Note: There are four locking knobs under back section, and two knobs under seat section.

Installation

Step 2: Rotate locking knobs to locked position.

Models: 222 (-015 thru -017) | 223 (-015 thru -016)
Serial Numbers: All | All

Upholstered Top
(Ritter models)

C-6.1

Component Testing & Repair

Upholstered Top (Midmark models)

Removal / Installation

Refer To:	Page
Exploded Views / Part Numbers:	
Upholstery - Midmark:	
Premium	E-8
Ultra-Premium	E-9

Removal
Step 3: Lift back section to disengage velcro, then push toward head end.

Installation
Step 1: Slide back section toward foot end to engage T-block.

Models w/ upholstery heater only

Removal
Step 1: Disconnect wire harness.

Installation
Step 3: Connect wire harness.
Note: Do not pinch wire.

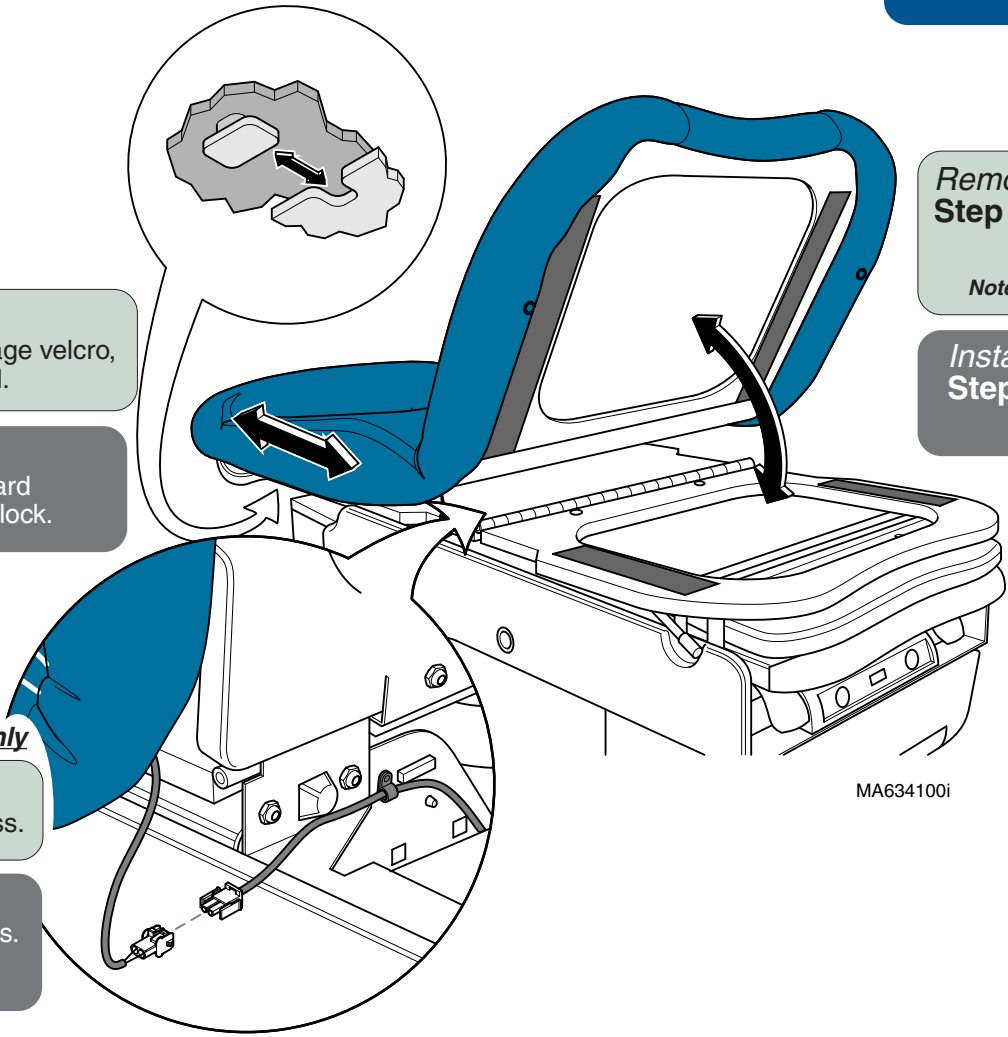

Removal
Step 2: Hold mounting frame in place, then lift seat section.
Note: Upholstery is secured with velcro.

Installation
Step 2: Lower seat section and press down firmly to engage velcro.

MA634100i

Upholstered Top (Midmark models)

Removal / Installation

Step 2 applies only to models with optional upholstery heater.

Removal

Step 2: Disconnect upholstery heater harness.

Installation



Equipment Alert

Be sure harness is not pinched between upholstery & upperwrap.

Step 2: Connect upholstery heater harness.

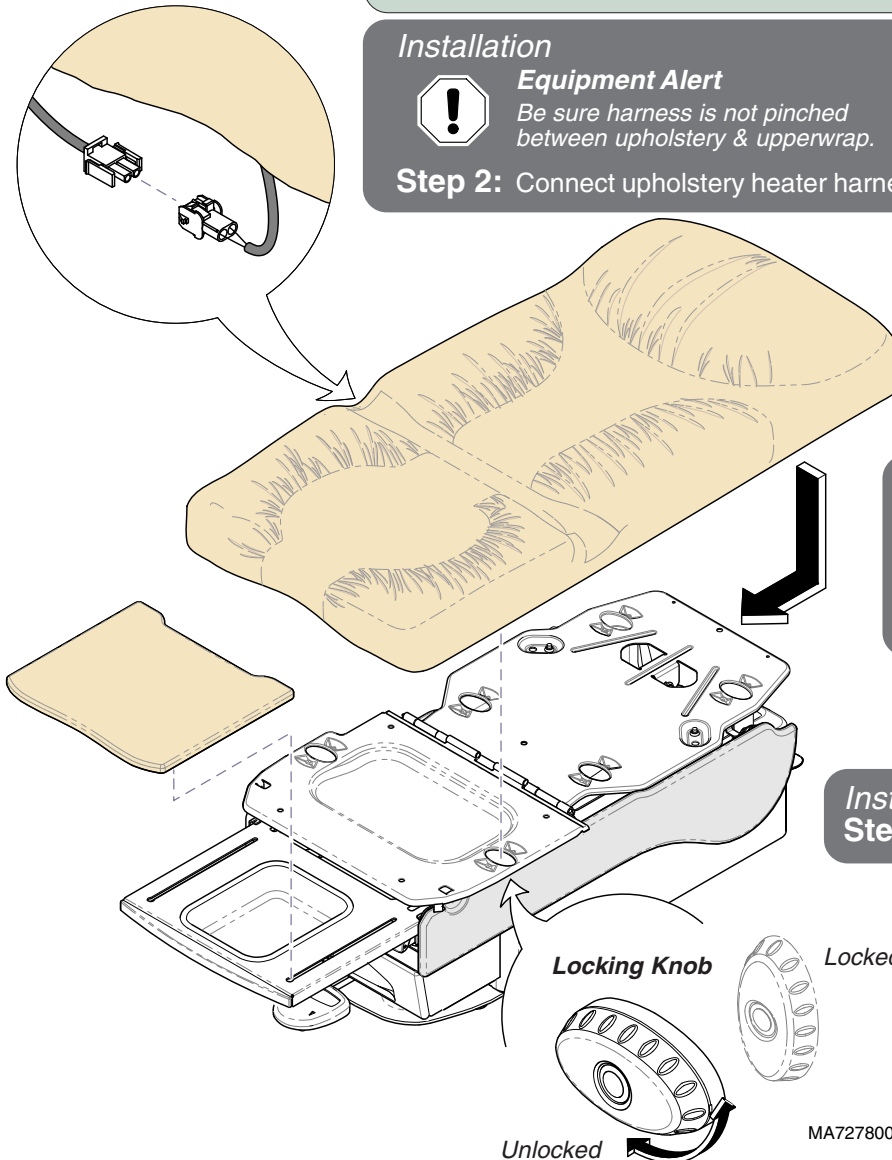

Removal

Step 3: Remove upholstered top & footrest pad.

Note: Slide upholstery up to remove from back support plate.

Installation

Step 1: Position upholstered top & footrest pad on table.

Note: Back support plate must slide under paper roll holder.

Be sure locking knobs align with holes in back / seat mounting plates.

Installation

Step 3: Rotate locking knobs to locked position.

Removal

Step 1: Rotate all locking knobs to unlocked position.

Note: There are four locking knobs under back section, and two knobs under seat section.

MA727800i

Models: 622 (-007 & -008)
Serial Numbers: All

623 (-007 thru -010)
All

Upholstered Top
(Midmark models)

Component Testing & Repair

Chair Arms / Brace (optional)

Removal

Refer To: [Page](#)

Exploded Views / Part Numbers:

Refer to Midmark Medical Accessory
Service & Parts Manual (004-0096-00)

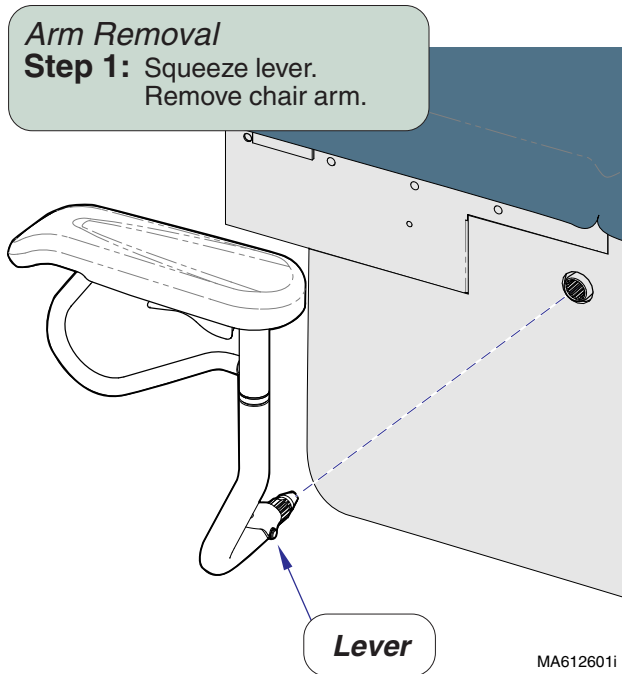

It may be necessary to remove the chair arm brace when performing certain procedures.

Arm Brace Removal

Step 1: Remove table shrouds.

Arm Brace Removal
Step 3: Remove brace.

Arm Brace Removal

Step 2: Remove two screws.
Repeat on opposite side.

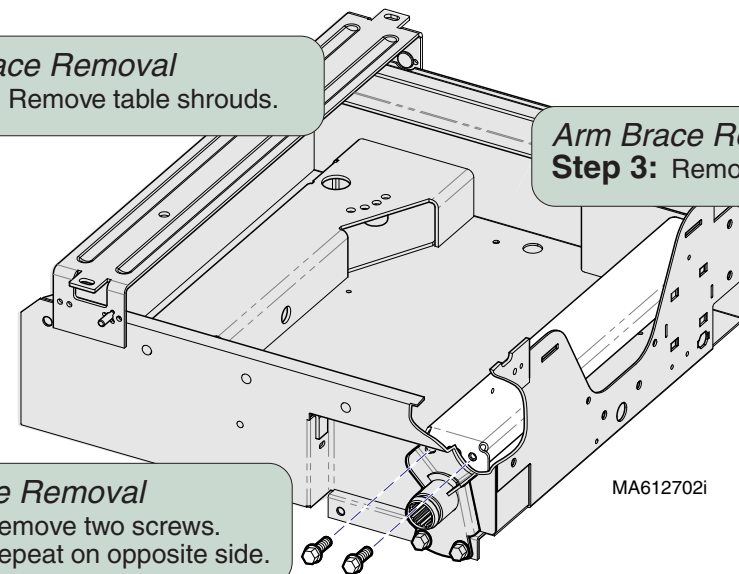

Top Cover (Back Limit Switch Access)

Removal / Installation

Removal

Step 1: Lower table shrouds.
Refer to: Section C - Table Shrouds

Installation

Step 2: Reattach table shrouds.

Removal

Step 2: Remove screws securing top cover.

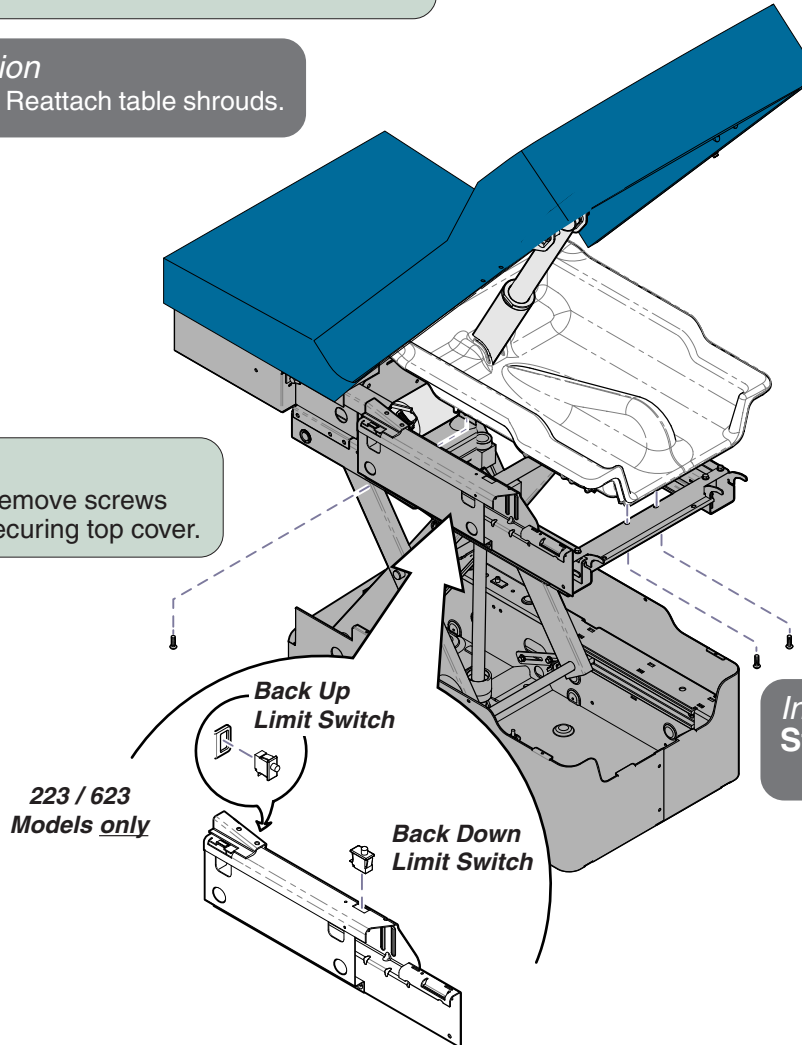

Installation

Step 2: Secure top cover with screws removed in Step 2.

Refer To:

Table Shrouds C-2

Page

Removal

Note

The back limit switches can be accessed without completely removing the top cover. But if removing the cover is necessary, perform Step 3.

Step 3: Partially separate the back lift cylinder as shown. Slide top cover off of cylinder.

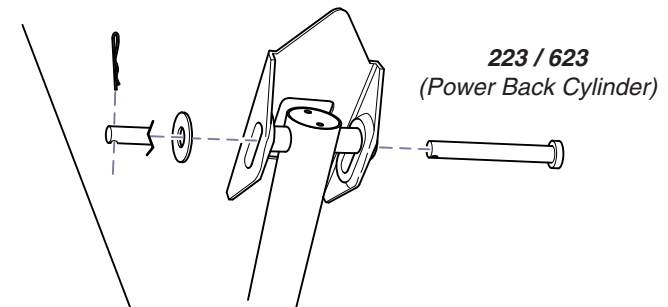

Installation

Step 1: Slide top cover over back cylinder. Reattach back cylinder.

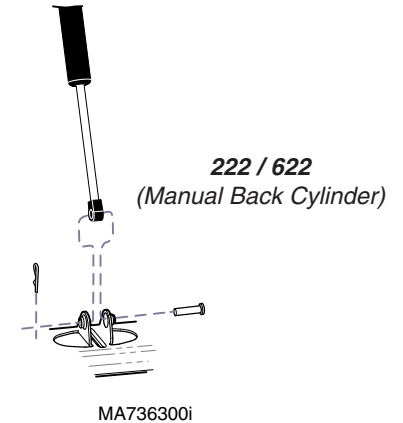

Models:
Serial Numbers:

All
All

Top Cover

Wiring Diagrams

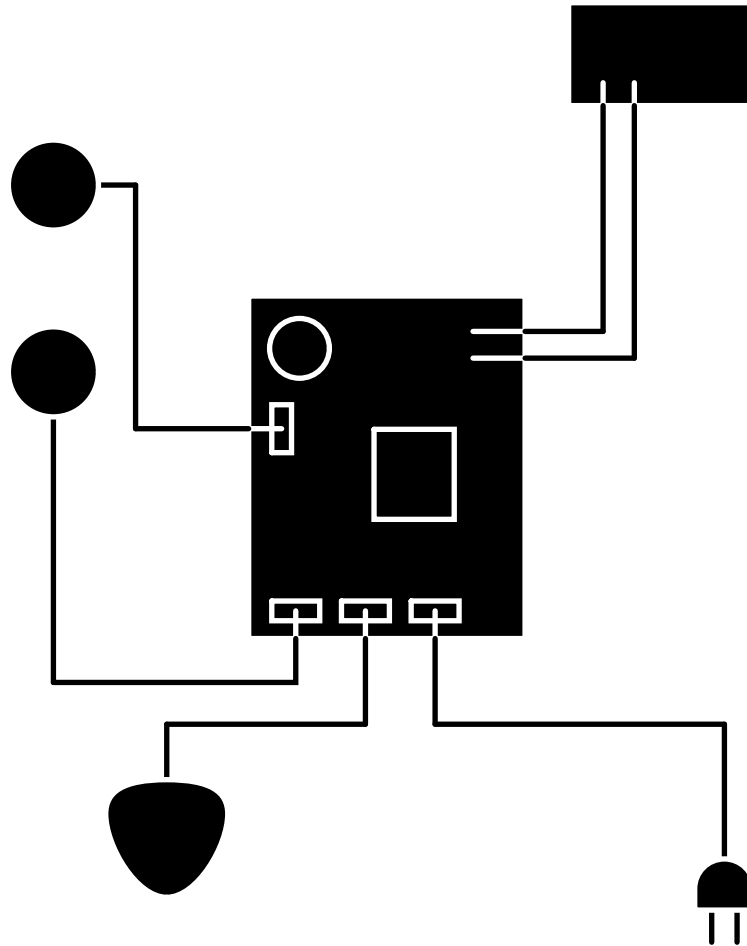

Model	Page
222:	
(-001 & -005)	D-2
(-002 & -006)	D-3
(-003 & -007)	D-4
(-004 & -008)	D-5
(-009 & -017)	D-6
(-010)	D-7
(-011 & -013)	D-8
(-012 & -014)	D-9
(-015)	D-10
(-016)	D-11
223:	
(-001 & -005)	D-12
(-002 & -006)	D-13
(-003 & -007)	D-14
(-004 & -008)	D-15
(-009)	D-16
(-010)	D-17
(-011 & -013)	D-18
(-012 & -014)	D-19
(-015)	D-20
(-016)	D-21
622:	
(-001)	D-3
(-002)	D-22
(-003)	D-6
(-004)	D-23
(-005)	D-8
(-006)	D-24
(-007)	D-10
(-008)	D-25
623:	
(-001)	D-26
(-002)	D-27
(-003 & -009)	D-28
(-004)	D-29
(-005)	D-30
(-006)	D-31
(-007)	D-32
(-008)	D-33
(-010)	D-29*

Wiring Diagrams

Refer To: Page
Fuses E-24

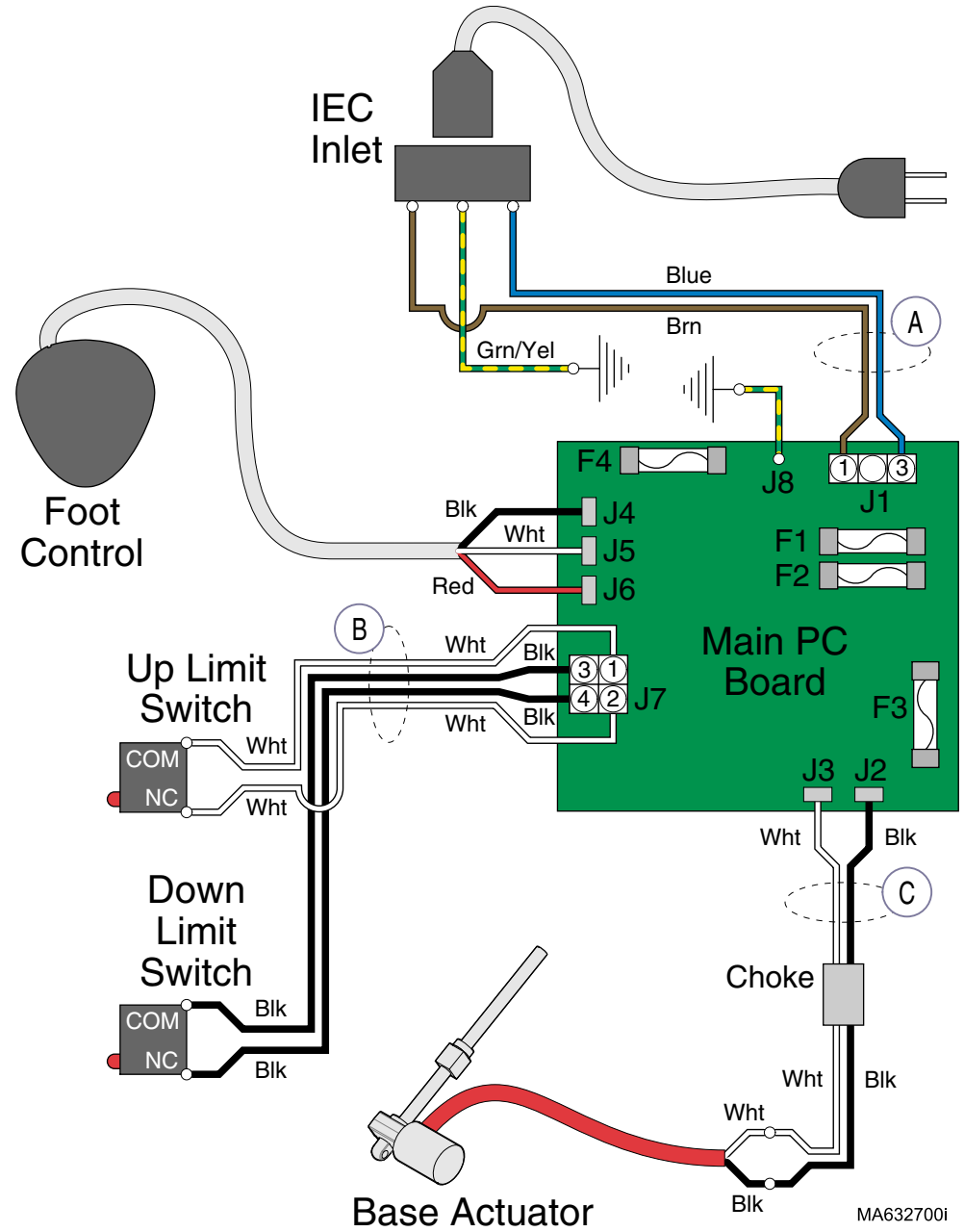

Wire Harness	From:	To:	Part Number
A	IEC Inlet	Main PC Board	015-1579-00 (includes Item B)
B	Base Up/Down Limit Switches	Main PC Board	015-1579-00 (includes Item A)
C	Base Actuator Wires	Main PC Board	015-1635-00 (includes choke)

Wiring Diagrams

Refer To: **Page**
Fuses **E-24**

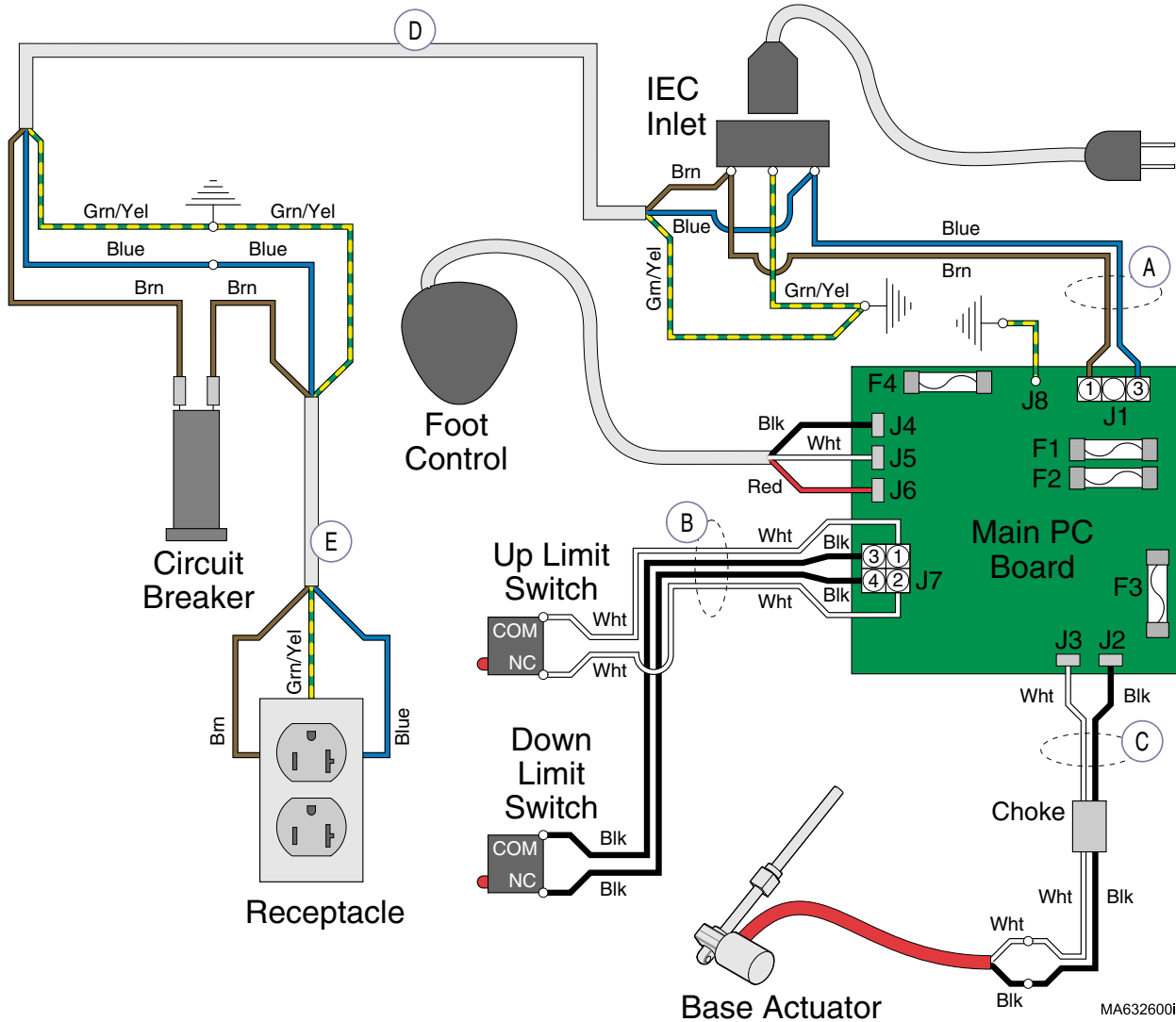

Wire Harness	From:	To:	Part Number
A	IEC Inlet	Main PC Board	015-1579-00 <i>(includes Item B)</i>
B	Base Up/Down Limit Switches	Main PC Board	015-1579-00 <i>(includes Item A)</i>
C	Base Actuator Wires	Main PC Board	015-1635-00 <i>(includes choke)</i>
D	Circuit Breaker	IEC Inlet	015-1594-30
E	Receptacle	Circuit Breaker	015-1595-00

Models: | **222 (-002 & -006)** | **622 (-001)**
Serial Numbers: | all | all

Wiring Diagrams

Wiring Diagrams

Refer To: _____ Page _____
 Fuses E-24

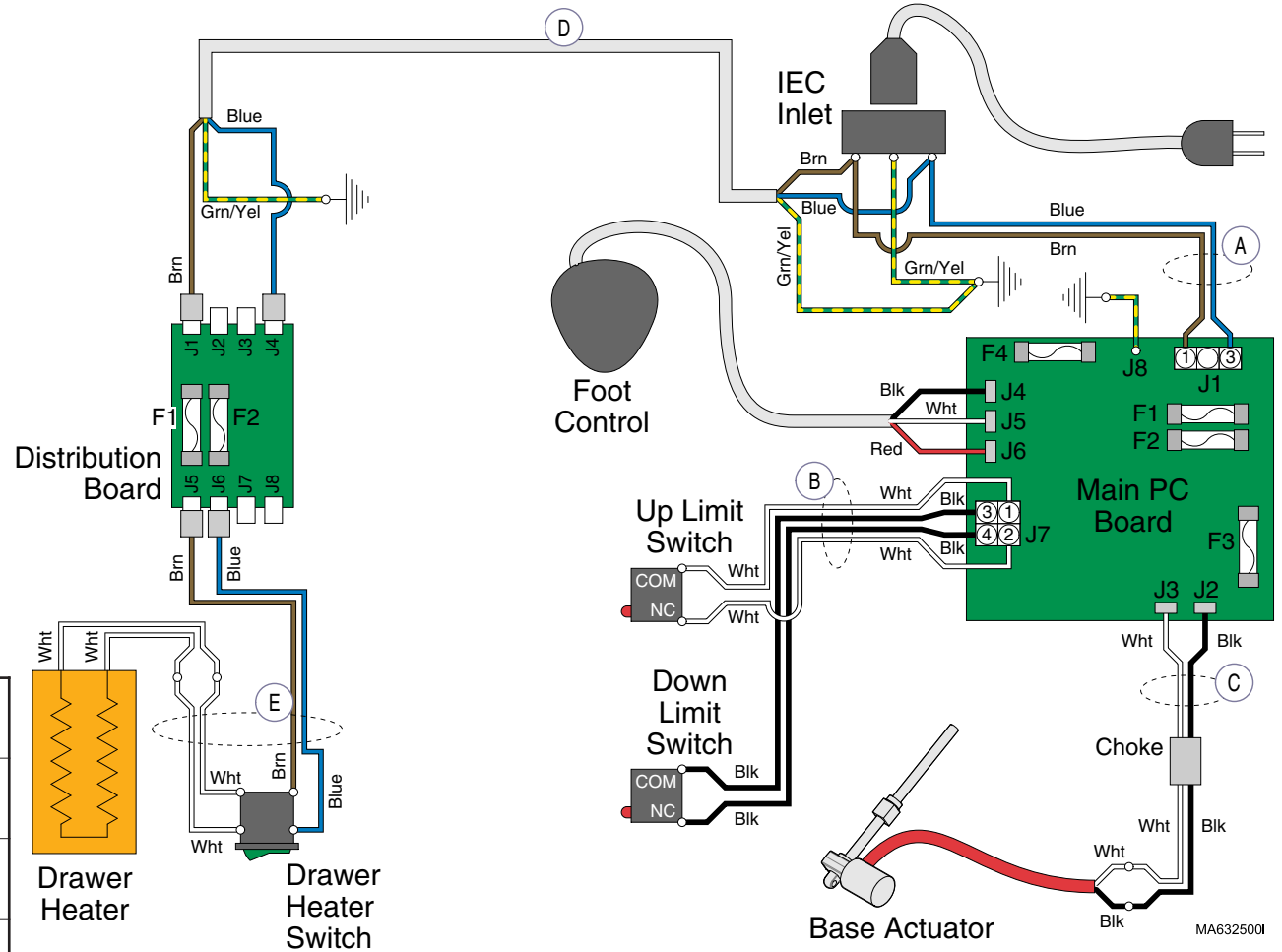

Wire Harness	From:	To:	Part Number
A	IEC Inlet	Main PC Board	015-1579-00 <i>(includes Item B)</i>
B	Base Up/Down Limit Switches	Main PC Board	015-1579-00 <i>(includes Item A)</i>
C	Base Actuator Wires	Main PC Board	015-1635-00 <i>(includes choke)</i>
D	Distribution Board	IEC Inlet	015-1594-00
E	Heater Plate / Heater Switch	Distribution Board	015-1629-00

Wiring Diagrams

Refer To: **Page**
Fuses E-24

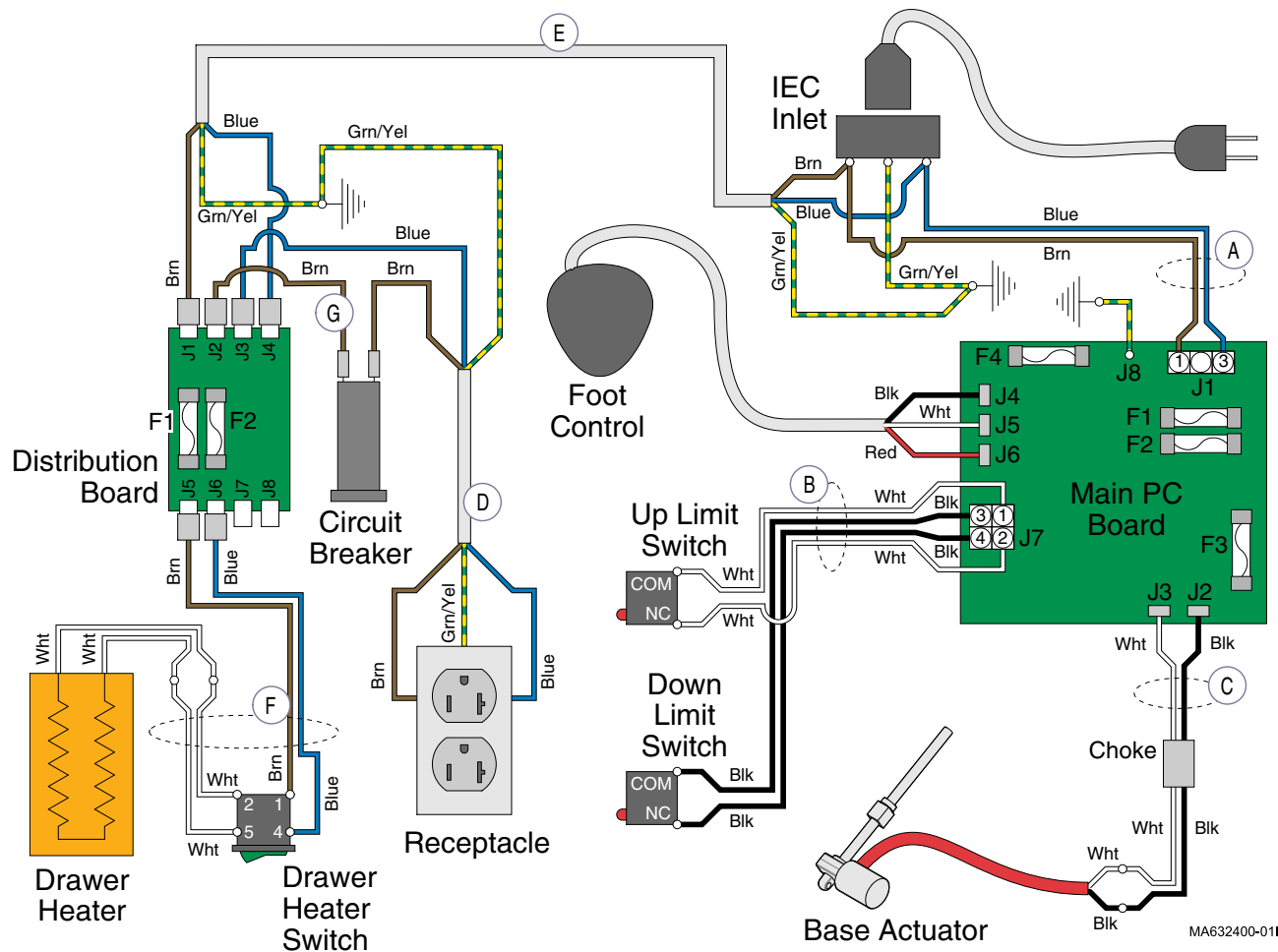

Wire Harness	From:	To:	Part Number
A	IEC Inlet	Main PC Board	015-1579-00 <i>(includes Item B)</i>
B	Base Up/Down Limit Switches	Main PC Board	015-1579-00 <i>(includes Item A)</i>
C	Base Actuator Wires	Main PC Board	015-1635-00 <i>(includes choke)</i>
D	Receptacle	Circuit Breaker	015-1595-00
E	Distribution Board	IEC Inlet	015-1594-00
F	Heater Plate / Heater Switch	Distribution Board	015-1629-00
G	Circuit Breaker	Distribution Board	015-0708-30

Models: 222 (-004 & -008)
Serial Numbers: all

Wiring Diagrams

Wiring Diagrams

Refer To: Page
Fuses E-24

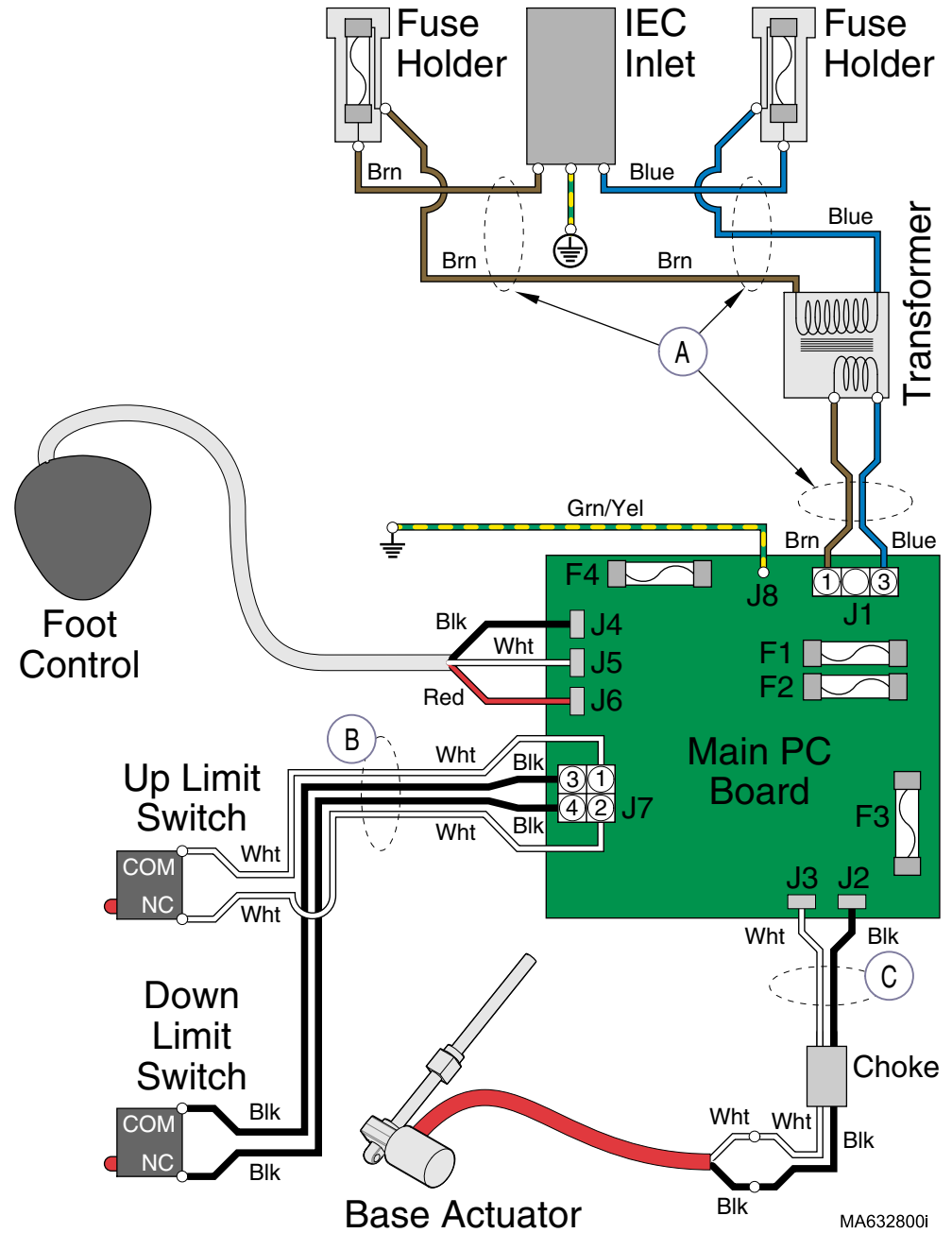

Wire Harness	From:	To:	Part Number
A	IEC Inlet / Fuse Holders / Transformer	Main PC Board	015-1580-00 <i>(includes Item B)</i>
B	Base Up/Down Limit Switches	Main PC Board	015-1580-00 <i>(includes Item A)</i>
C	Base Actuator Wires	Main PC Board	015-1635-00 <i>(includes choke)</i>

Wiring Diagrams

Refer To: **Page**
Fuses **E-24**

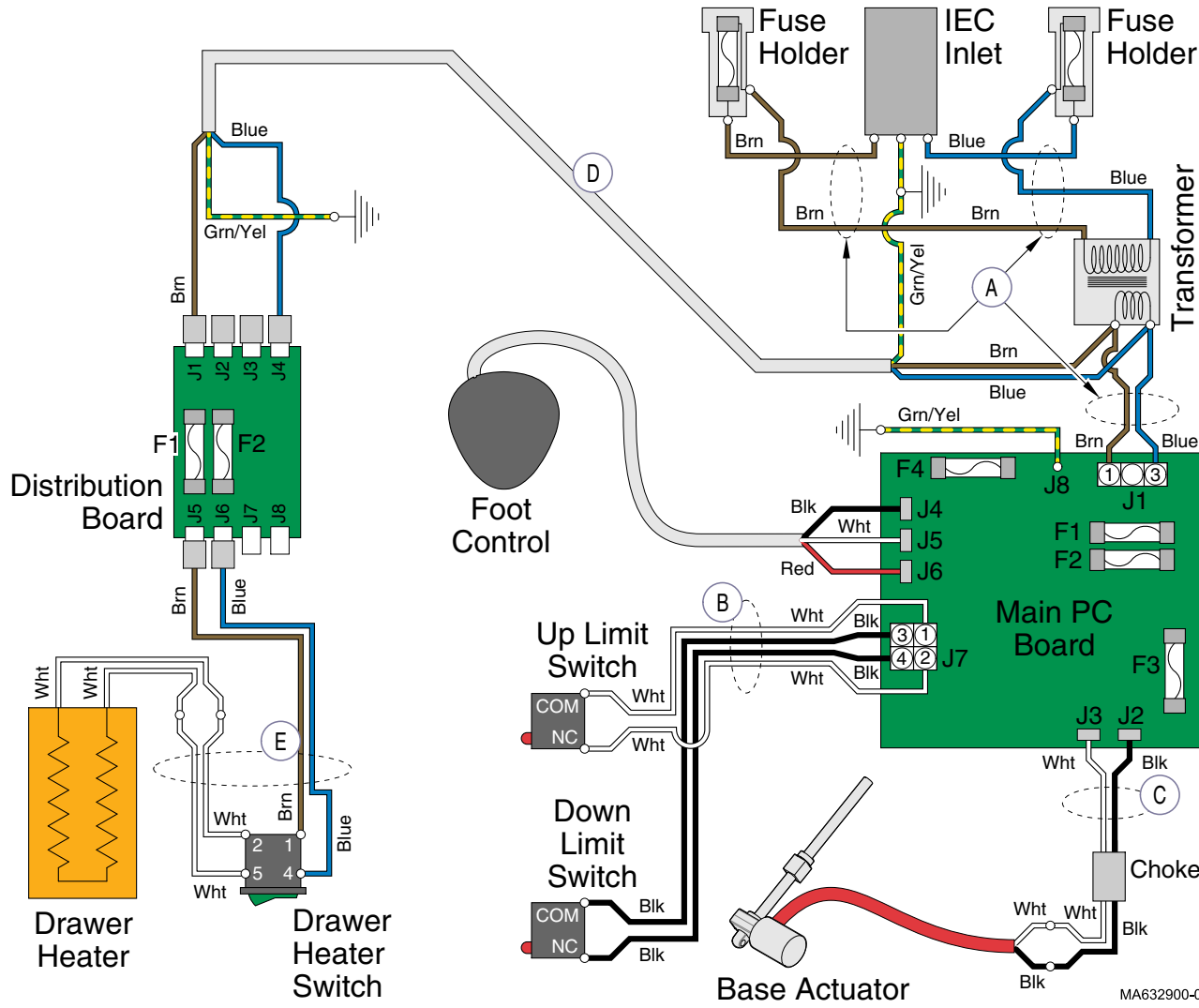

Wire Harness	From:	To:	Part Number
A	IEC Inlet / Fuse Holders / Transformer	Main PC Board	015-1580-00 <i>(includes Item B)</i>
B	Base Up/Down Limit Switches	Main PC Board	015-1580-00 <i>(includes Item A)</i>
C	Base Actuator Wires	Main PC Board	015-1635-00 <i>(includes choke)</i>
D	Distribution Board	Transformer	015-1594-00
E	Heater Plate / Heater Switch	Distribution Board	015-1629-00

Models: 222 (-010)
Serial Numbers: all

Wiring Diagrams

Wiring Diagrams

Refer To: **Page**
Fuses E-24

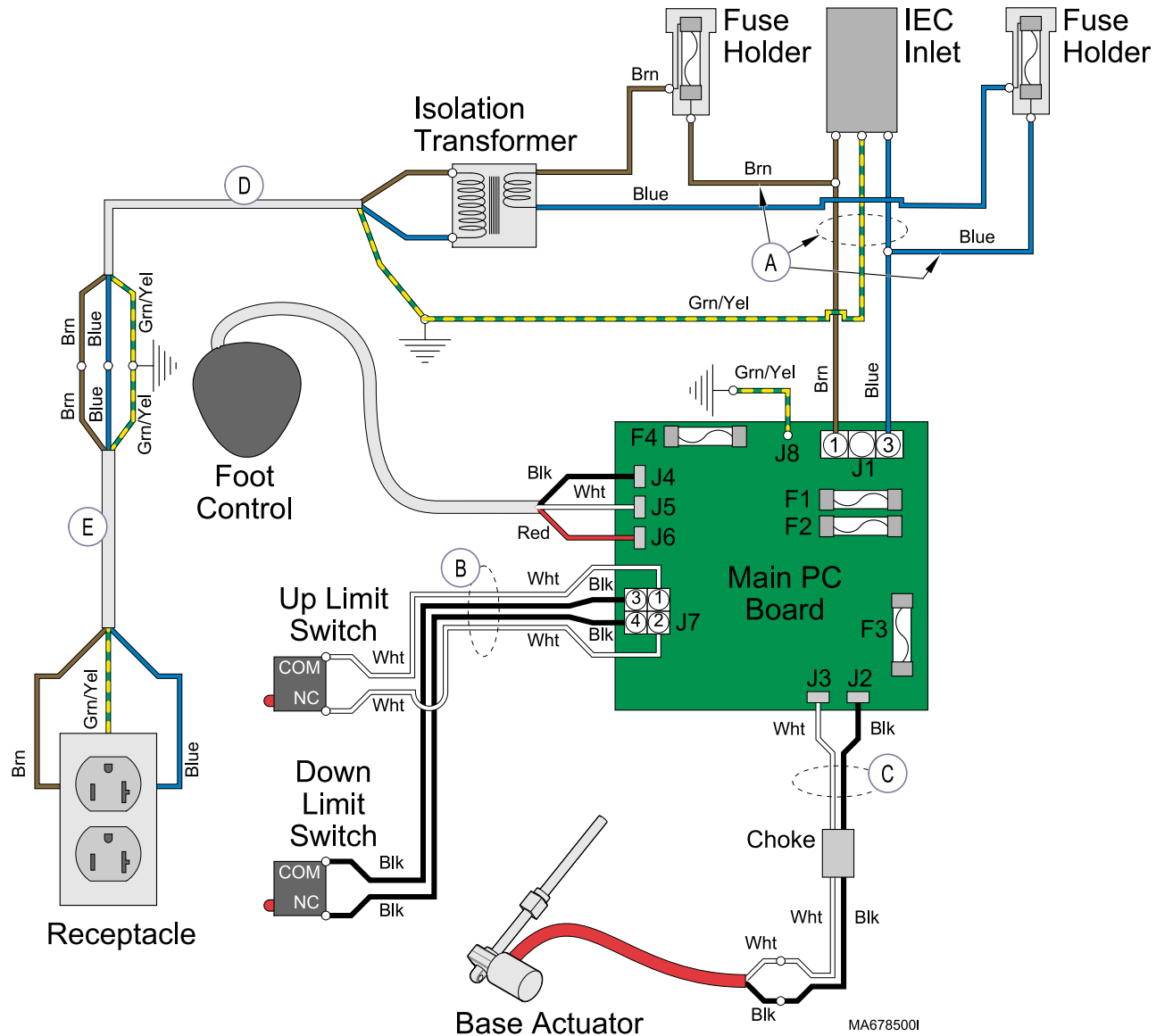

Wire Harness	From:	To:	Part Number
A	IEC Inlet	Main PC Board	015-1852-00 <i>(includes Item B)</i>
B	Base Up/Down Limit Switches	Main PC Board	015-1852-00 <i>(includes Item A)</i>
C	Base Actuator Wires	Main PC Board	015-1635-00 <i>(includes choke)</i>
D	Isolation Transformer	Item E	015-1845-00
E	Receptacle	Item D	015-1595-00

Wiring Diagrams

Refer To: Page
 Fuses E-24

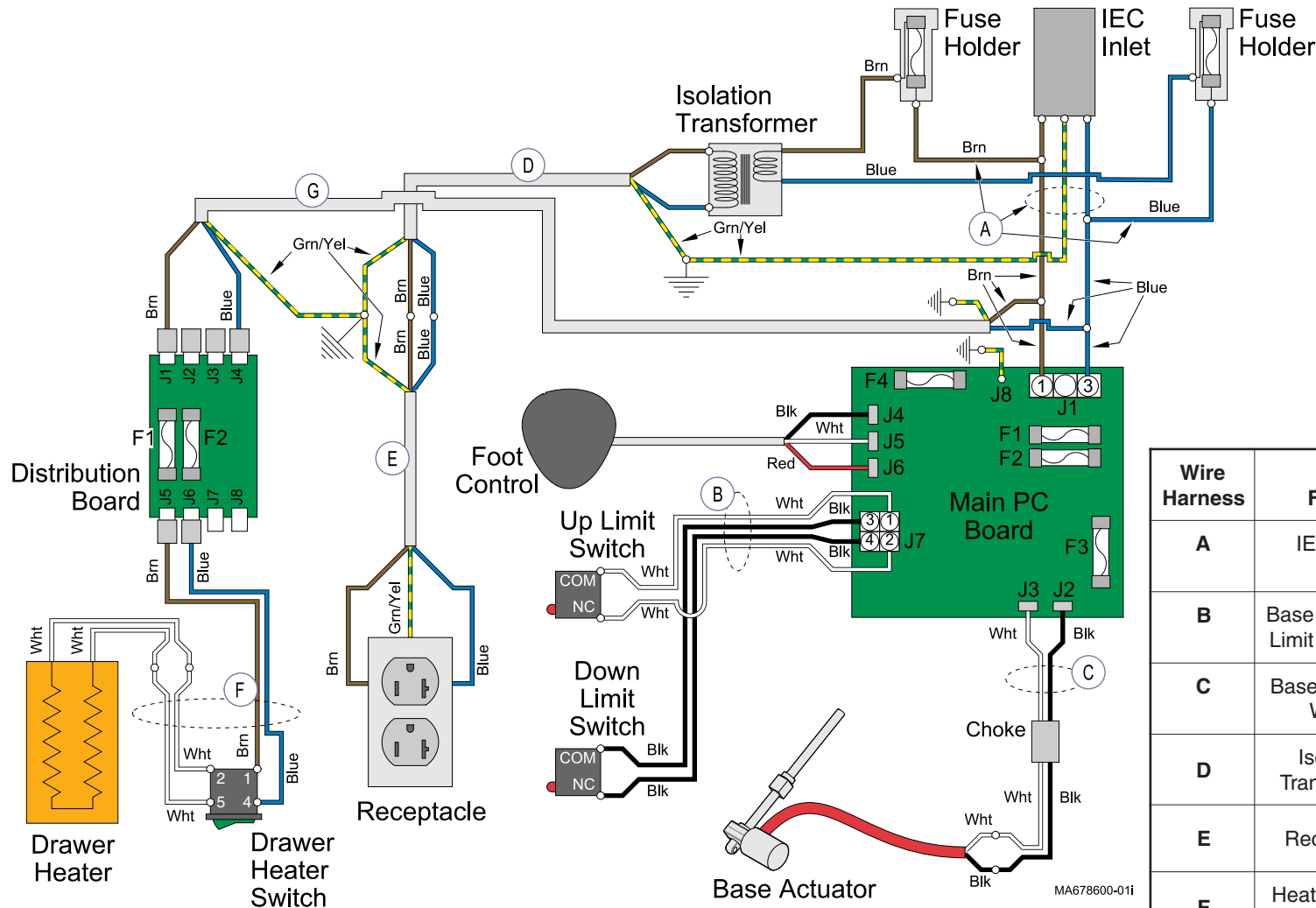

Wire Harness	From:	To:	Part Number
A	IEC Inlet	Main PC Board	015-1852-00 <i>(includes Item B)</i>
B	Base Up/Down Limit Switches	Main PC Board	015-1852-00 <i>(includes Item A)</i>
C	Base Actuator Wires	Main PC Board	015-1635-00 <i>(includes choke)</i>
D	Isolation Transformer	Item E	015-1845-00
E	Receptacle	Item D	015-1595-00
F	Heater Plate / Heater Switch	Distribution Board	015-1629-00
G	Distribution Board	Item A	015-1594-00

Models: 222 (-012 & -014)
Serial Numbers: all

Wiring Diagrams

Wiring Diagrams

Refer To: _____ Page _____
 Fuses E-24

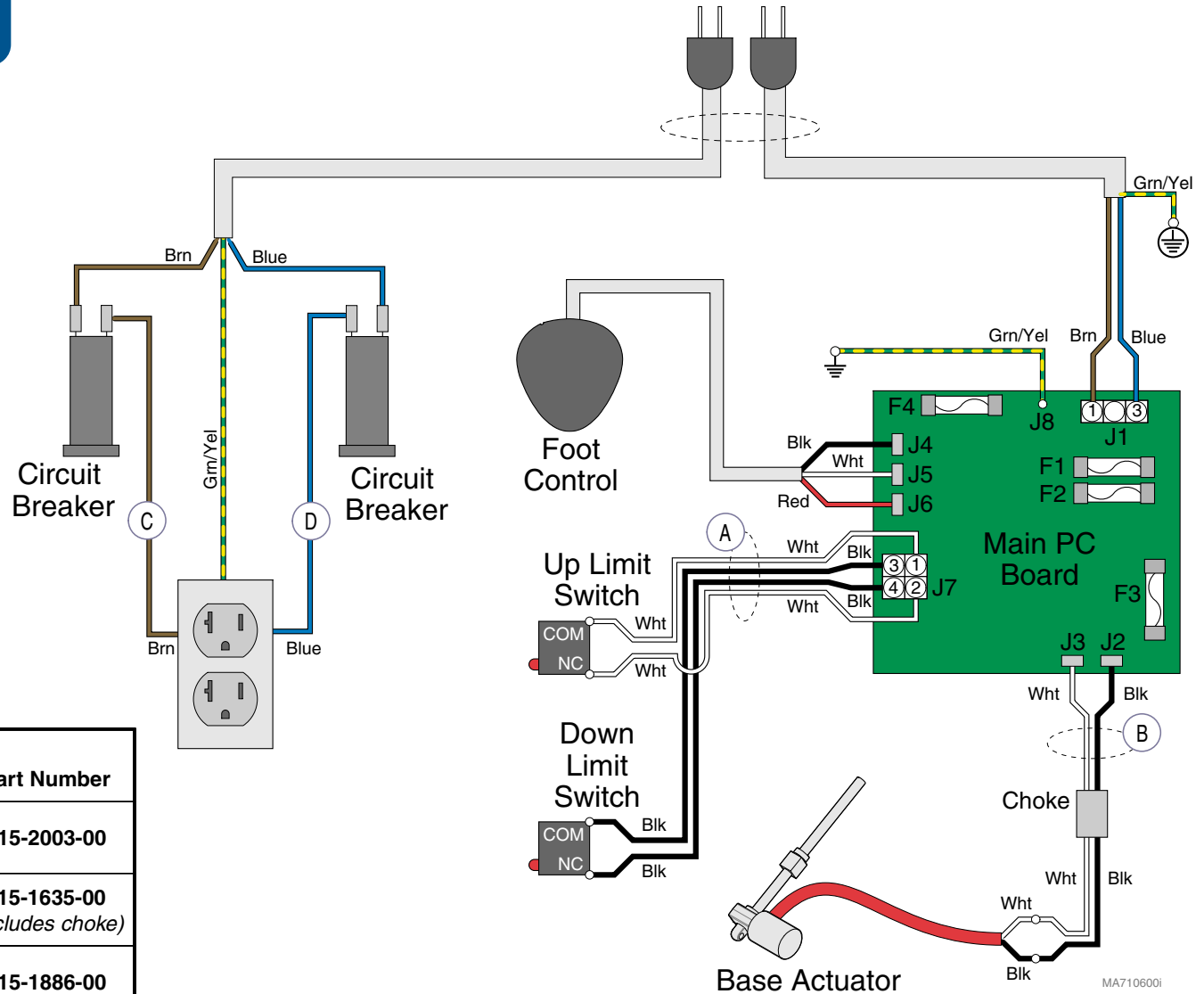

Wire Harness	From:	To:	Part Number
A	BaseUp / Down Limit Switches	Main PC Board	015-2003-00
B	Base Actuator Wires	Main PC Board	015-1635-00 (includes choke)
C	Circuit Breaker (brown wire)	Table Receptacle	015-1886-00
D	Circuit Breaker (blue wire)	Table Receptacle	015-1886-01

Wiring Diagrams

Refer To: Page
Fuses E-24

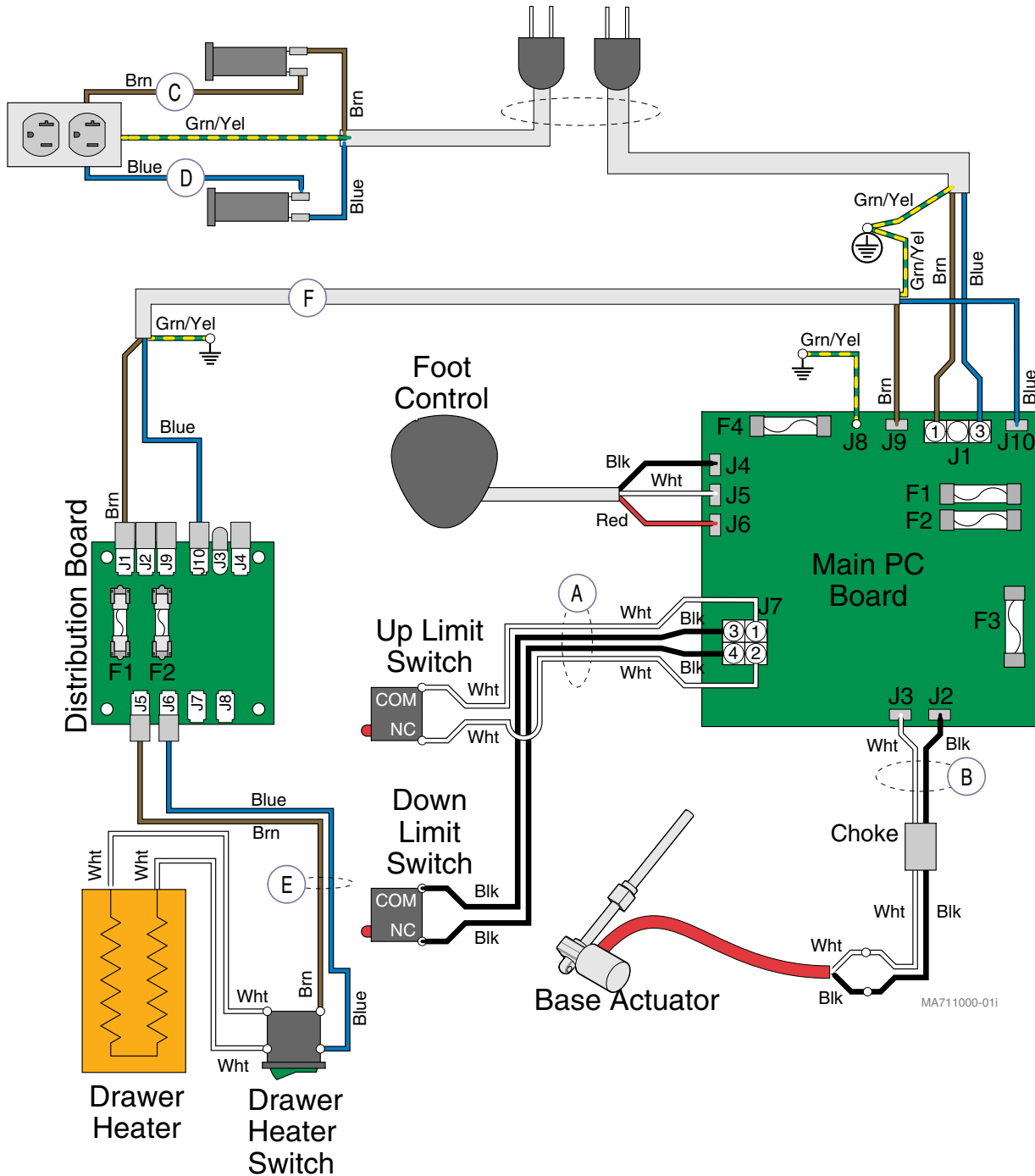

Wire Harness	From:	To:	Part Number
A	BaseUp / Down Limit Switches	Main PC Board	015-2003-00
B	Base Actuator Wires	Main PC Board	015-1635-00 (incl. choke)
C	Circuit Breaker (brown wire)	Table Receptacle	015-1886-00
D	Circuit Breaker (blue wire)	Table Receptacle	015-1886-01
E	Heater Switch	Distribution Board	015-2004-00
F	Distribution Board	Main PC Board	015-2005-00

Models: 222 (-016)
Serial Numbers: all

Wiring Diagrams

Wiring Diagrams

Refer To: Page
Fuses E-24

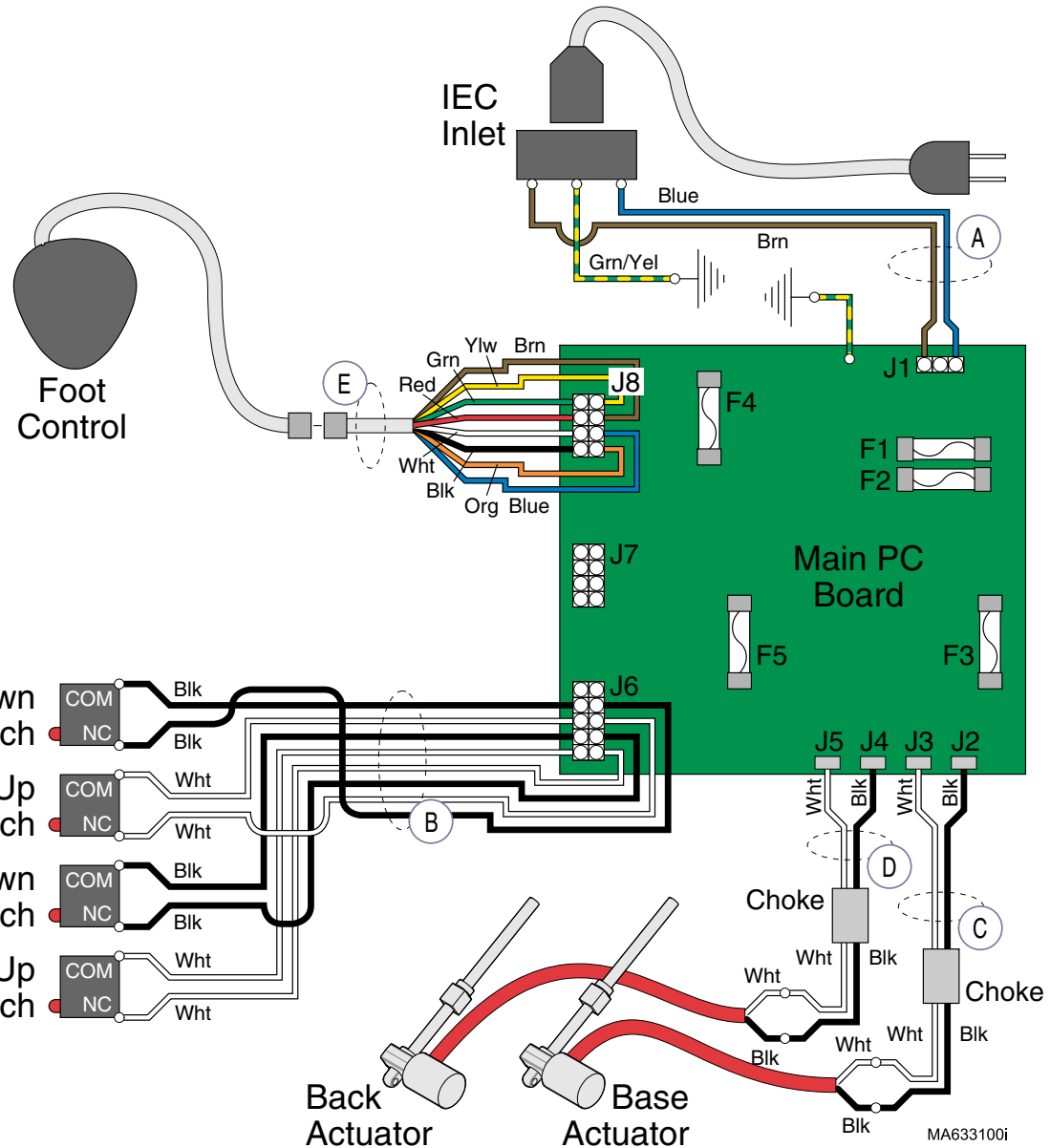

Wire Harness	From:	To:	Part Number
A	IEC Inlet	Main PC Board	015-1744-00 <i>(includes Item B)</i>
B	Base & Back Limit Switches	Main PC Board	015-1744-00 <i>(includes Item A)</i>
C	Base Actuator Wires	Main PC Board	015-1635-00 <i>(includes choke)</i>
D	Back Actuator Wires	Main PC Board	015-1635-00 <i>(includes choke)</i>
E	Foot Control Inlet	Main PC Board	015-1784-00

Wiring Diagrams

Refer To: Page
 Fuses E-24

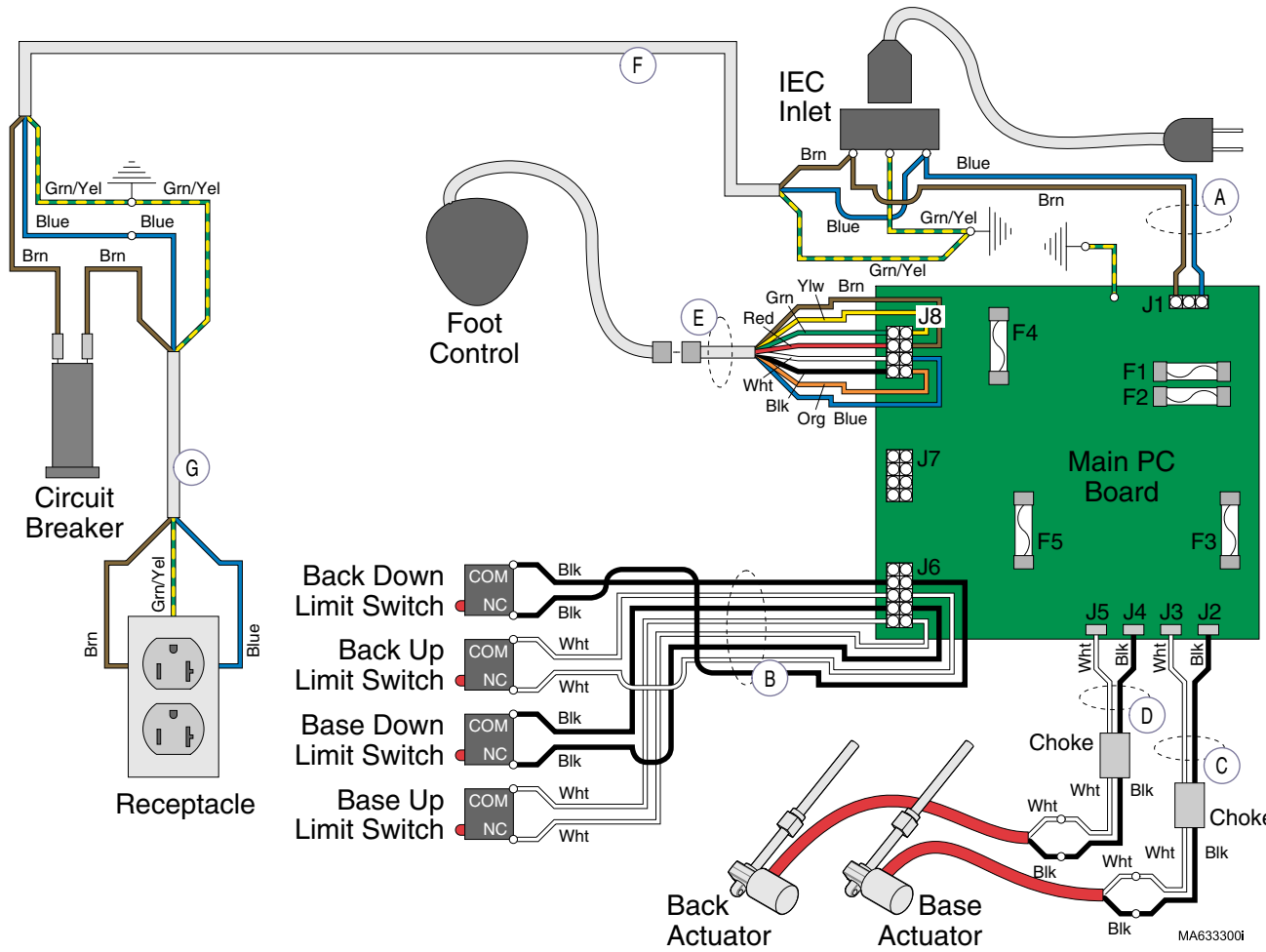

- Back Down Limit Switch
- Back Up Limit Switch
- Base Down Limit Switch
- Base Up Limit Switch

Wire Harness	From:	To:	Part Number
A	IEC Inlet	Main PC Board	015-1744-00 <i>(includes Item B)</i>
B	Base & Back Limit Switches	Main PC Board	015-1744-00 <i>(includes Item A)</i>
C	Base Actuator Wires	Main PC Board	015-1635-00 <i>(includes choke)</i>
D	Back Actuator Wires	Main PC Board	015-1635-00 <i>(includes choke)</i>
E	Foot Control Inlet	Main PC Board	015-1784-00
F	Circuit Breaker	IEC Inlet	015-1594-30
G	Receptacle	Circuit Breaker	015-1595-00

Models: 223 (-002 & -006)
Serial Numbers: all

Wiring Diagrams

Wiring Diagrams

Refer To: _____ Page _____
 Fuses E-24

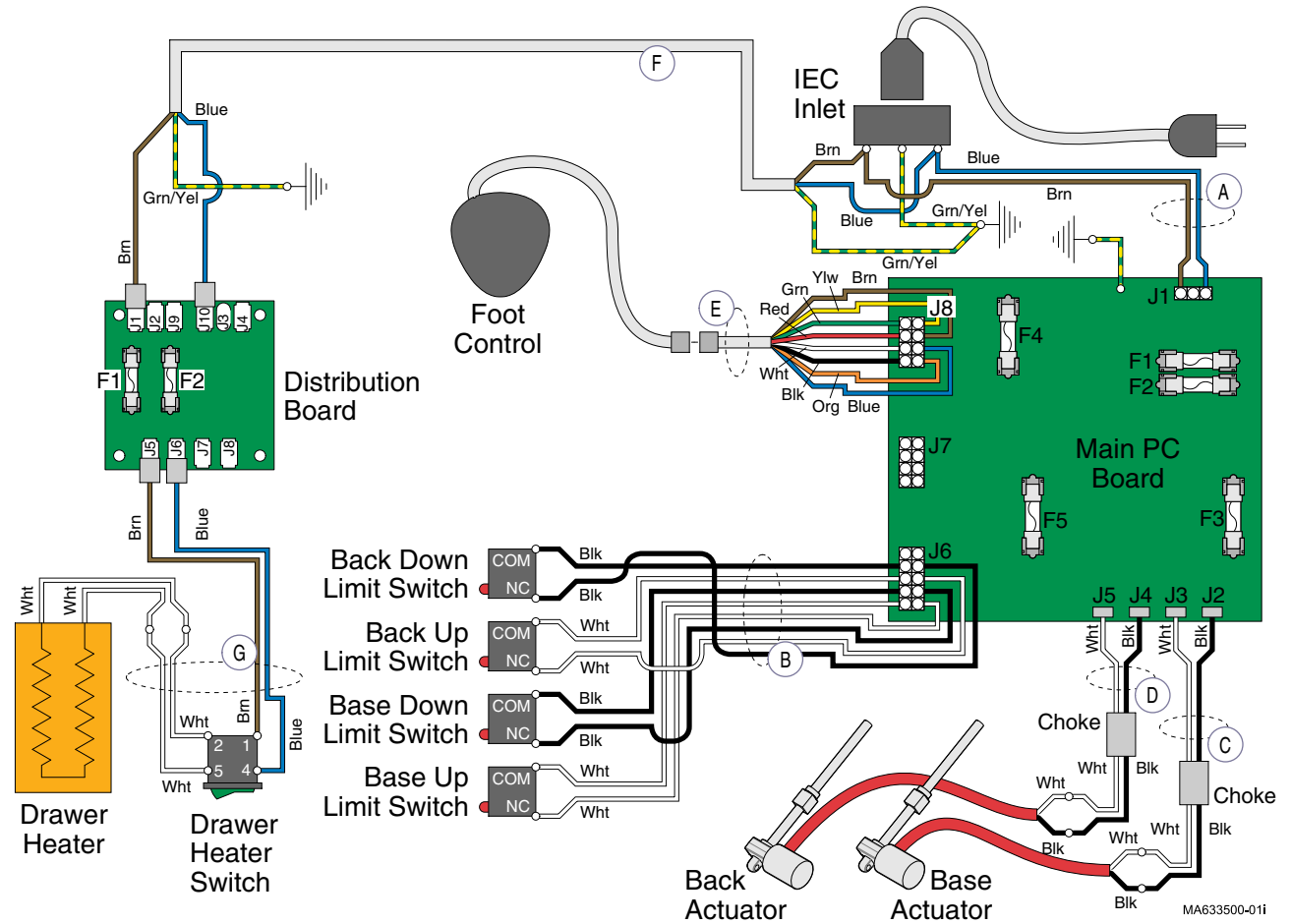

Wire Harness	From:	To:	Part Number
A	IEC Inlet	Main PC Board	015-1744-00 <i>(includes Item B)</i>
B	Base & Back Limit Switches	Main PC Board	015-1744-00 <i>(includes Item A)</i>
C	Base Actuator Wires	Main PC Board	015-1635-00 <i>(includes choke)</i>
D	Back Actuator Wires	Main PC Board	015-1635-00 <i>(includes choke)</i>
E	Foot Control Inlet	Main PC Board	015-1784-00
F	Distribution Board	IEC Inlet	015-1594-00
G	Heater Plate / Heater Switch	Distribution Board	015-1629-00

Wiring Diagrams

Refer To: Page
 Fuses E-24

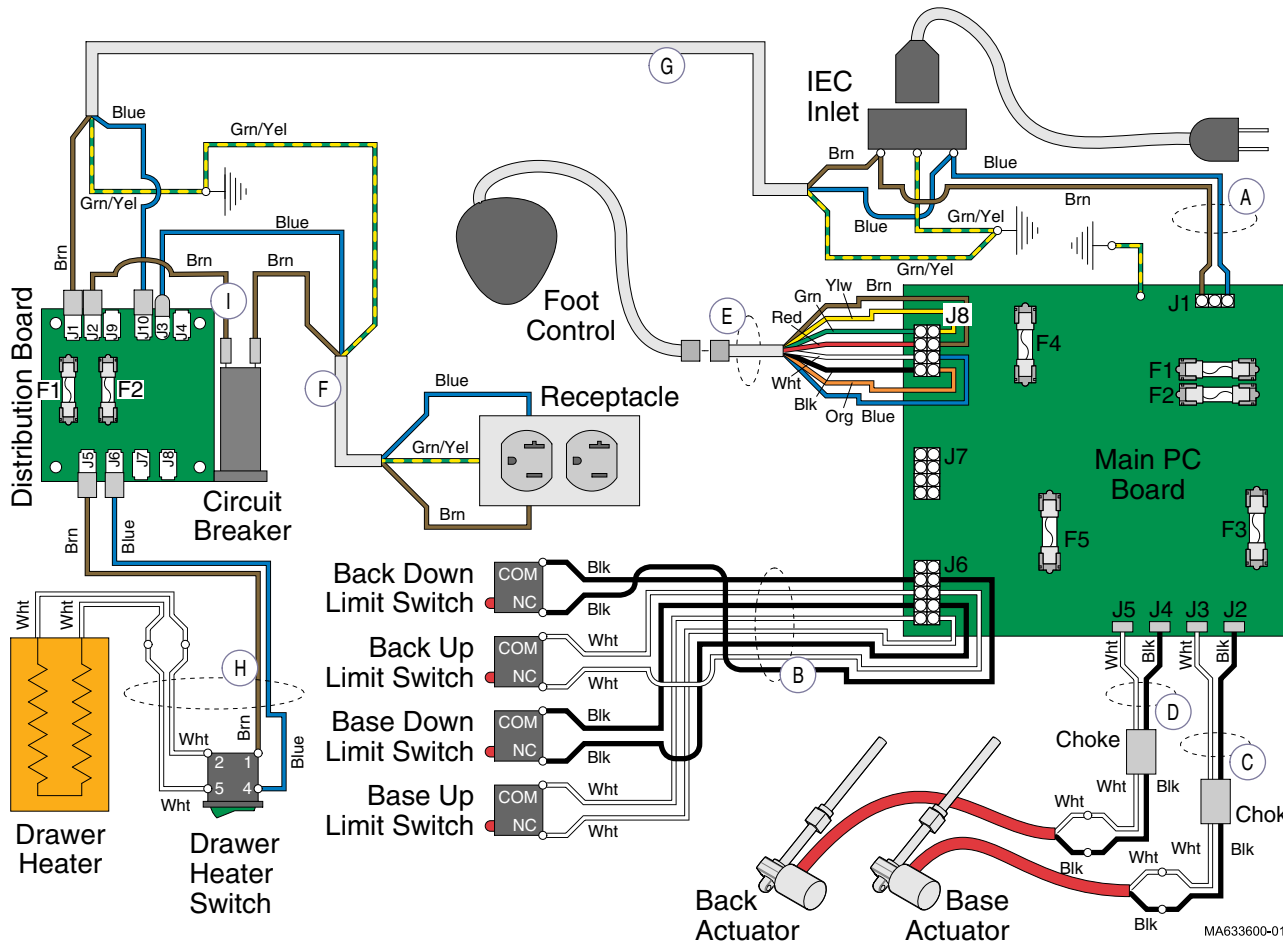

Wire Harness	From:	To:	Part Number
A	IEC Inlet	Main PC Board	015-1744-00 <i>(includes Item B)</i>
B	Base & Back Limit Switches	Main PC Board	015-1744-00 <i>(includes Item A)</i>
C	Base Actuator Wires	Main PC Board	015-1635-00 <i>(includes choke)</i>
D	Back Actuator Wires	Main PC Board	015-1635-00 <i>(includes choke)</i>
E	Foot Control Inlet	Main PC Board	015-1784-00
F	Receptacle	Circuit Breaker	015-1595-00
G	Distribution Board	IEC Inlet	015-1594-00
H	Heater Plate / Heater Switch	Distribution Board	015-1629-00
I	Circuit Breaker	Distribution Board	015-0708-30

Models: 223 (-004 & -008)
Serial Numbers: all

Wiring Diagrams

Wiring Diagrams

Refer To: Page
Fuses E-24

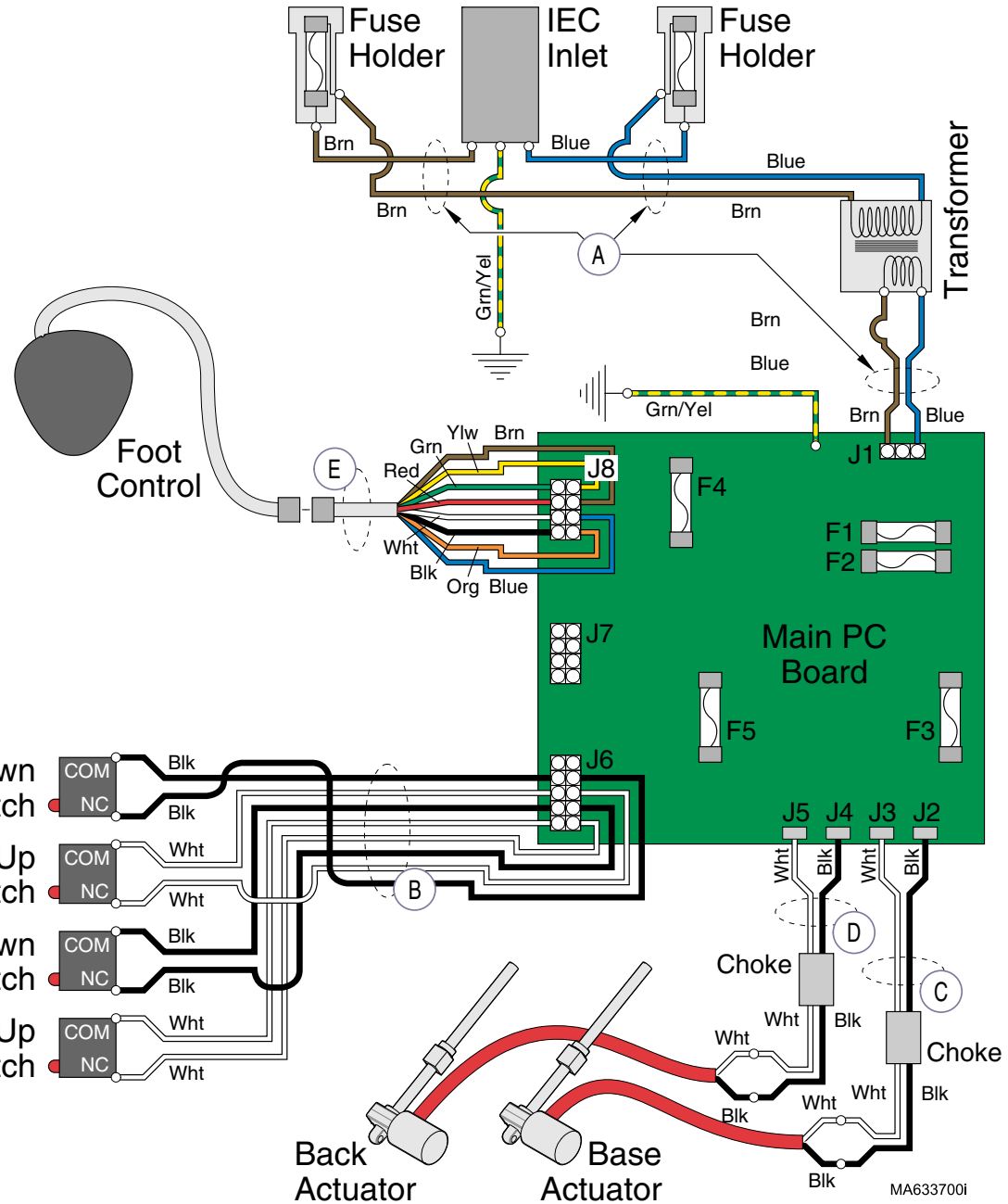

Wire Harness	From:	To:	Part Number
A	IEC Inlet	Main PC Board	015-1745-00 <i>(includes Item B)</i>
B	Base & Back Limit Switches	Main PC Board	015-1745-00 <i>(includes Item A)</i>
C	Base Actuator Wires	Main PC Board	015-1635-00 <i>(includes choke)</i>
D	Back Actuator Wires	Main PC Board	015-1635-00 <i>(includes choke)</i>
E	Foot Control Inlet	Main PC Board	015-1784-00

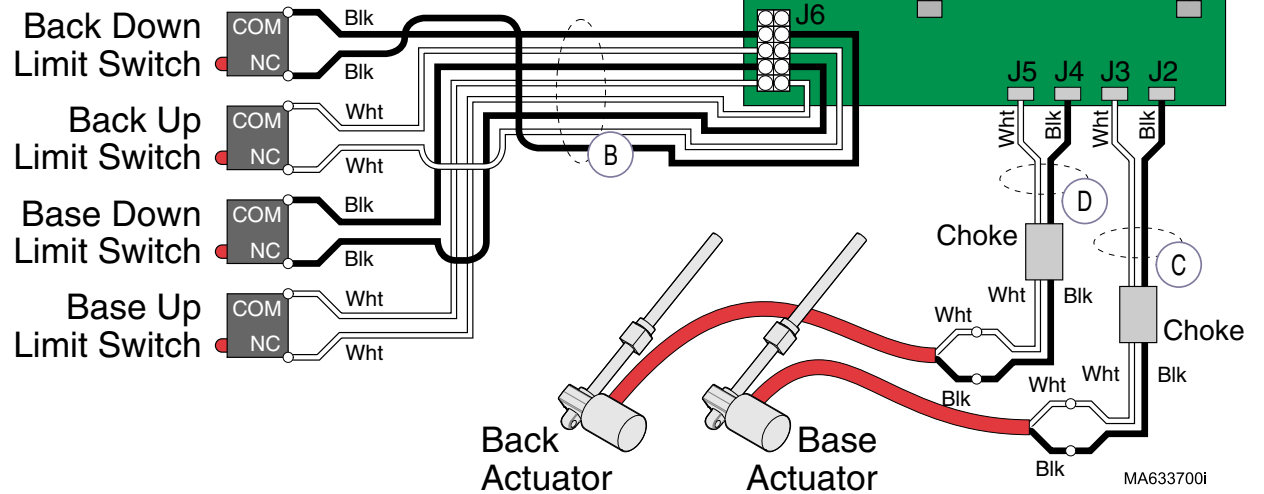

Wiring Diagrams

Refer To: **Page**
Fuses **E-24**

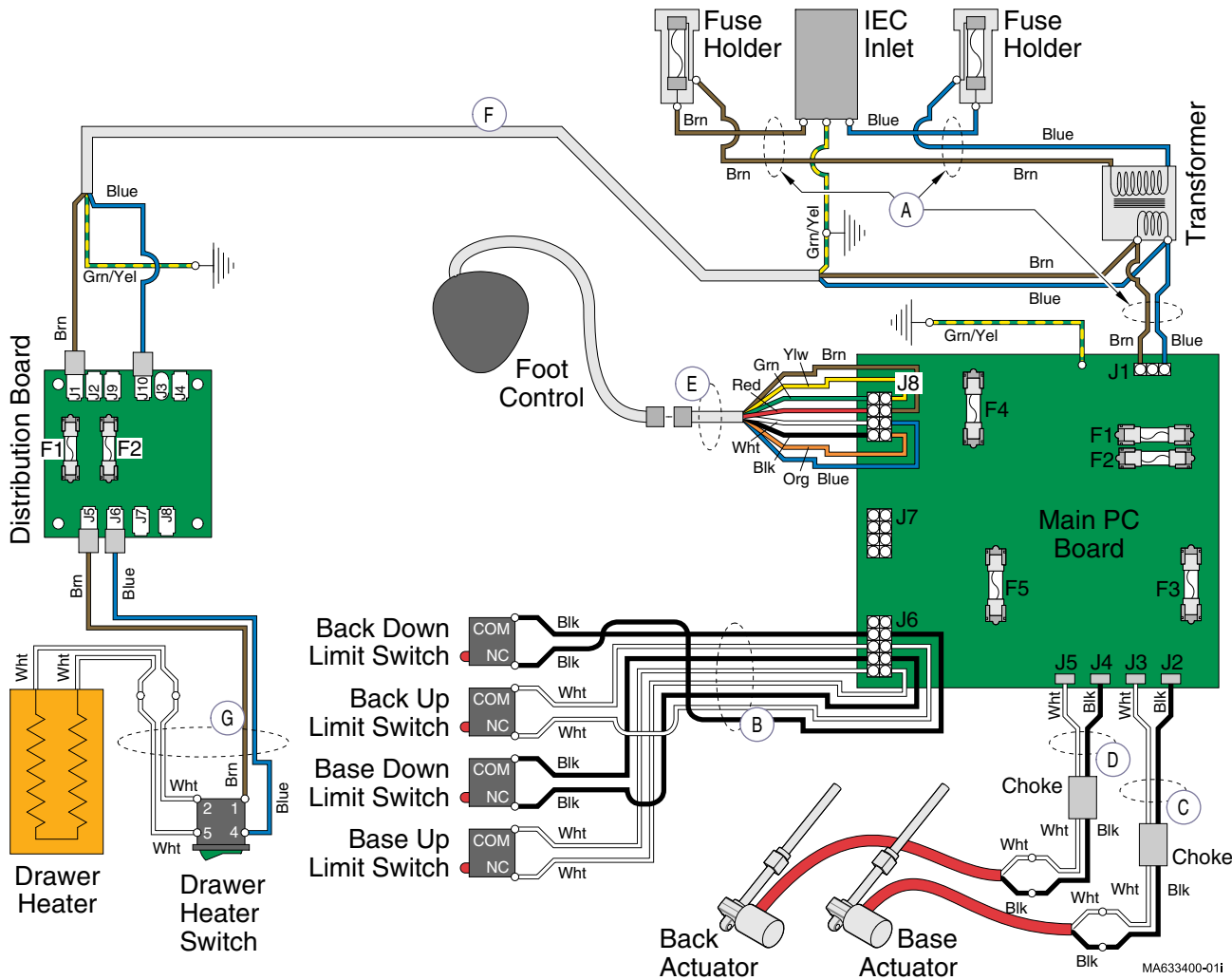

Wire Harness	From:	To:	Part Number
A	IEC Inlet	Main PC Board	015-1744-00 <i>(includes Item B)</i>
B	Base & Back Limit Switches	Main PC Board	015-1744-00 <i>(includes Item A)</i>
C	Base Actuator Wires	Main PC Board	015-1635-00 <i>(includes choke)</i>
D	Back Actuator Wires	Main PC Board	015-1635-00 <i>(includes choke)</i>
E	Foot Control Inlet	Main PC Board	015-1784-00
F	Distribution Board	Transformer	015-1594-00
G	Heater Plate / Heater Switch	Distribution Board	015-1629-00

Models: 223 (-010)
Serial Numbers: all

Wiring Diagrams

Wiring Diagrams

Refer To: Page
Fuses E-24

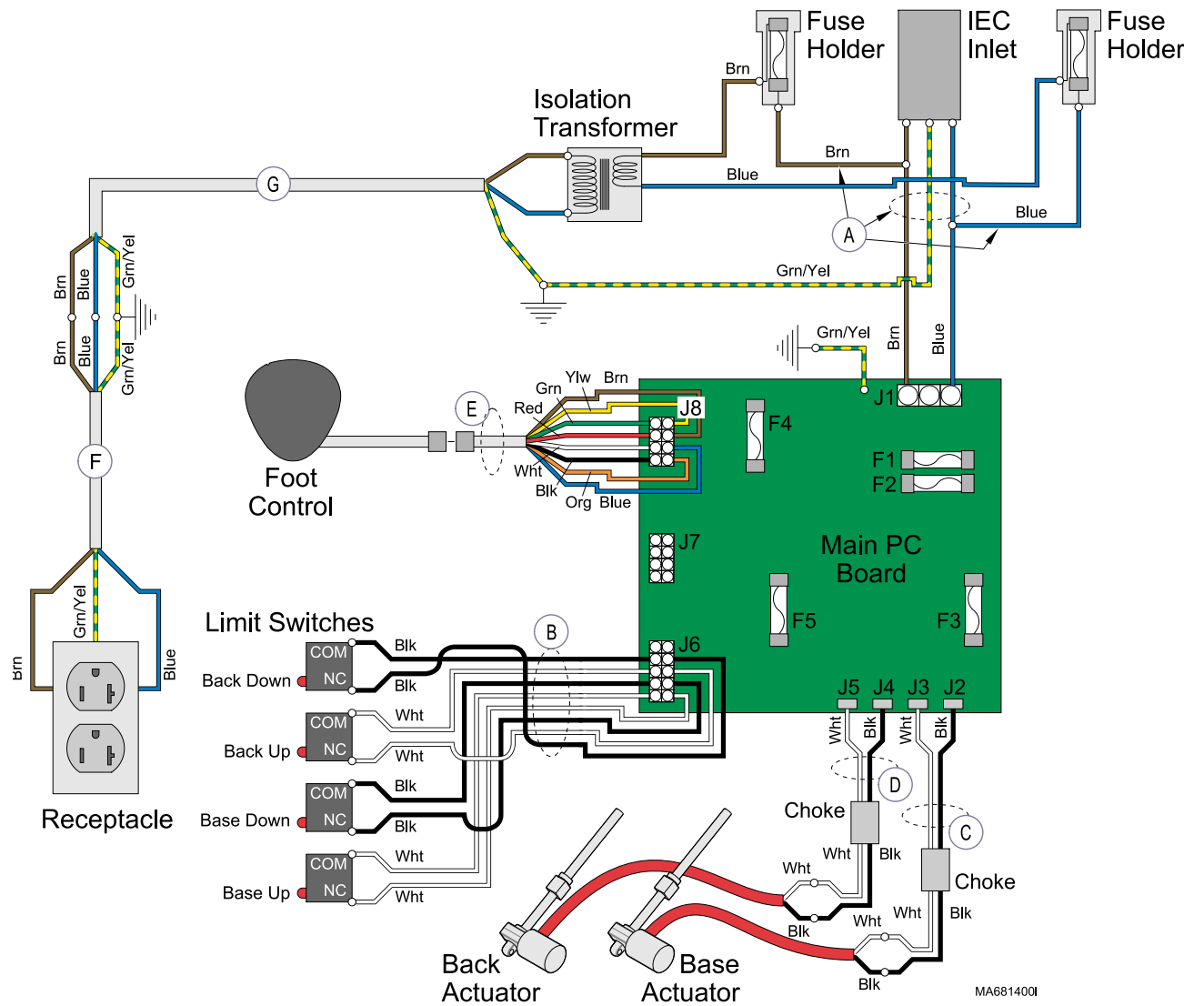

Wire Harness	From:	To:	Part Number
A	IEC Inlet	Main PC Board	015-1853-00 (includes Item B)
B	Base & Back Limit Switches	Main PC Board	015-1853-00 (includes Item A)
C	Base Actuator Wires	Main PC Board	015-1635-00 (includes choke)
D	Back Actuator Wires	Main PC Board	015-1635-00 (includes choke)
E	Foot Control Inlet	Main PC Board	015-1784-00
F	Receptacle	Item G	015-1595-00
G	Isolation Transformer	Item F	015-1845-00

Wiring Diagrams

Refer To: **Page**
Fuses **E-24**

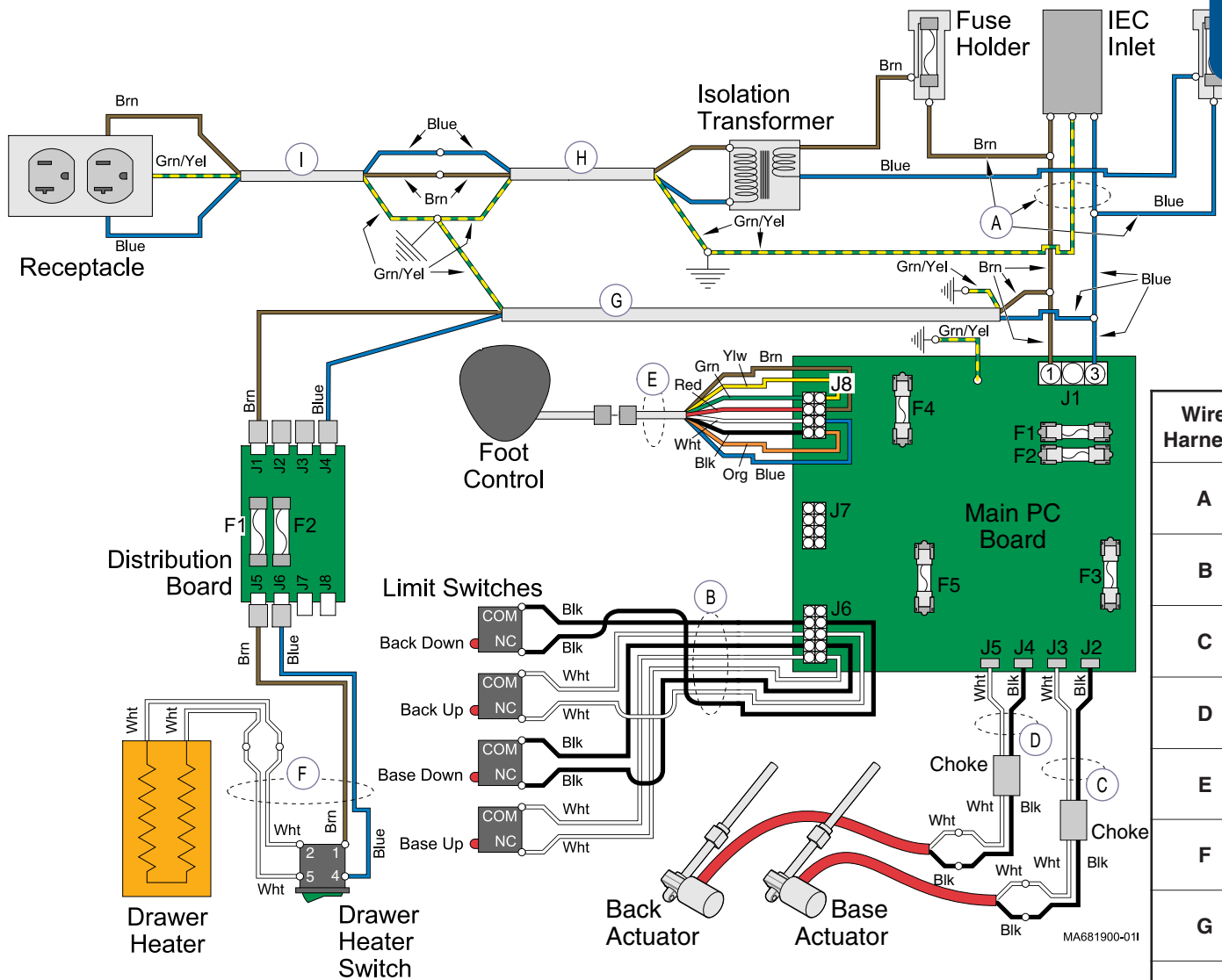

Wire Harness	From:	To:	Part Number
A	IEC Inlet	Main PC Board	015-1853-00 <i>(includes Item B)</i>
B	Base & Back Limit Switches	Main PC Board	015-1853-00 <i>(includes Item A)</i>
C	Base Actuator Wires	Main PC Board	015-1635-00 <i>(includes choke)</i>
D	Back Actuator Wires	Main PC Board	015-1635-00 <i>(includes choke)</i>
E	Foot Control Inlet	Main PC Board	015-1784-00
F	Drawer Heater / Heater Switch	Distribution Board	015-1629-00
G	Distribution Board	Item A	015-1594-00
H	Isolation Transformer	Item I	015-1845-00
I	Receptacle	Item H	015-1595-00

Models: 223 (-012 & -014)
Serial Numbers: all

Wiring Diagrams

Wiring Diagrams

Refer To: _____ Page _____
 Fuses E-24

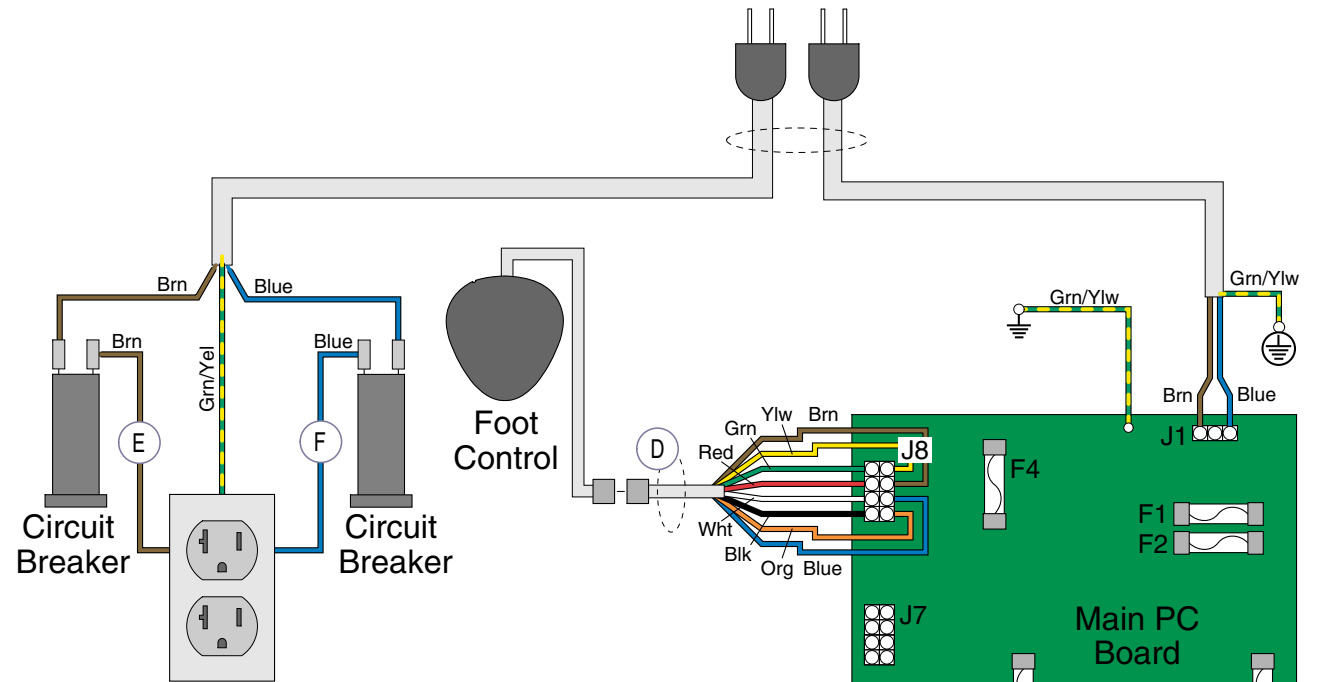

Wire Harness	From:	To:	Part Number
A	Base & Back Limit Switches	Main PC Board	015-2007-00
B	Base Actuator Wires	Main PC Board	015-1635-00 <i>(includes choke)</i>
C	Back Actuator Wires	Main PC Board	015-1635-00 <i>(includes choke)</i>
D	Foot Control	Main PC Board	015-1784-00
E	Circuit Breaker <i>(brown wire)</i>	Table Receptacle	015-1886-00
F	Circuit Breaker <i>(blue wire)</i>	Table Receptacle	015-1886-01

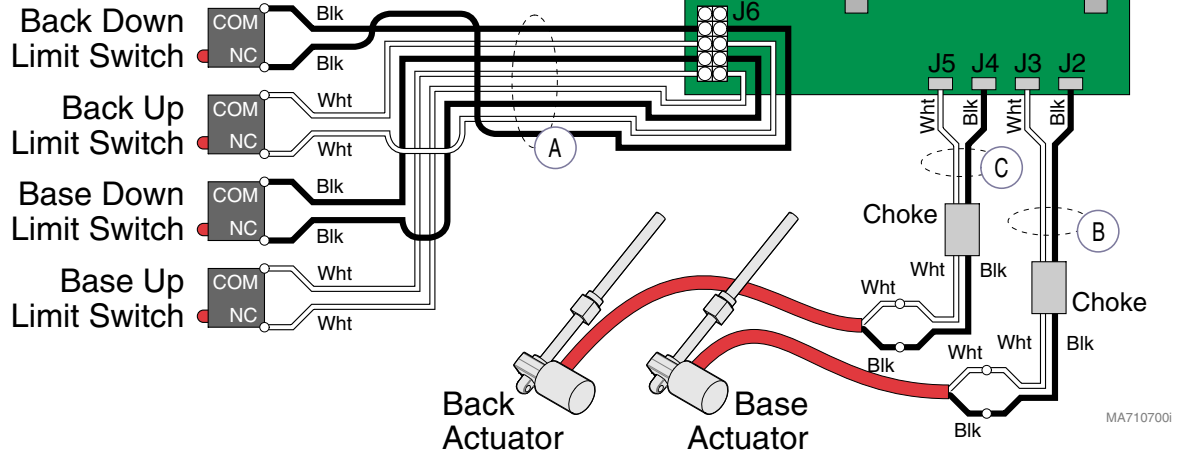

Wiring Diagrams

Refer To: _____ Page
Fuses E-24

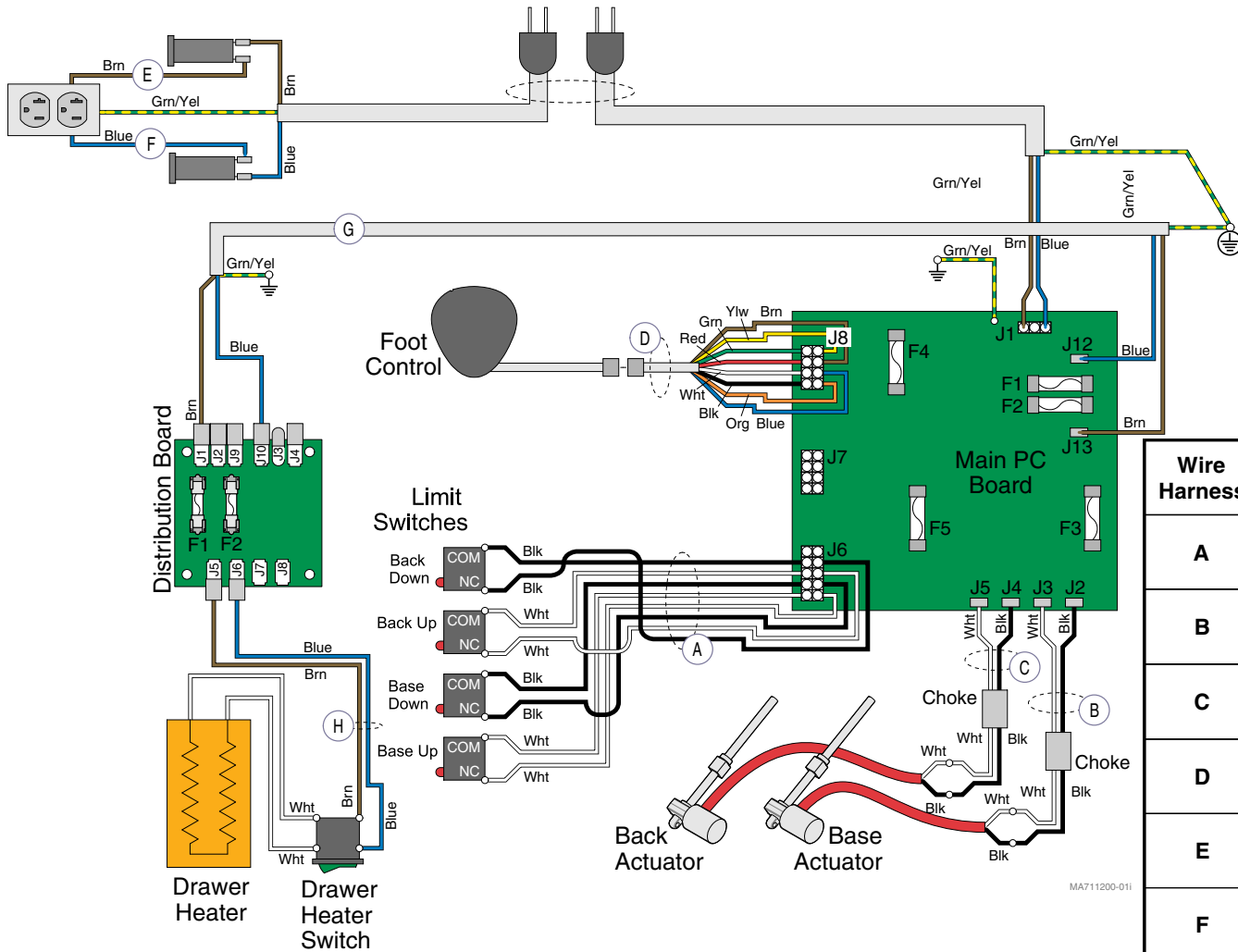

Wire Harness	From:	To:	Part Number
A	Base & Back Limit Switches	Main PC Board	015-2007-00
B	Base Actuator Wires	Main PC Board	015-1635-00 <i>(includes choke)</i>
C	Back Actuator Wires	Main PC Board	015-1635-00 <i>(includes choke)</i>
D	Foot Control Inlet	Main PC Board	015-1784-00
E	Circuit Breaker <i>(brown wire)</i>	Table Receptacle	015-1886-00
F	Circuit Breaker <i>(blue wire)</i>	Table Receptacle	015-1886-01
G	Distribution Board	Main PC Board	015-2005-00
H	Drawer Heater Switch	Distribution Board	015-2004-00

Models: 223 (-016)
Serial Numbers: all

Wiring Diagrams

Wiring Diagrams

Refer To: Page
 Fuses E-24

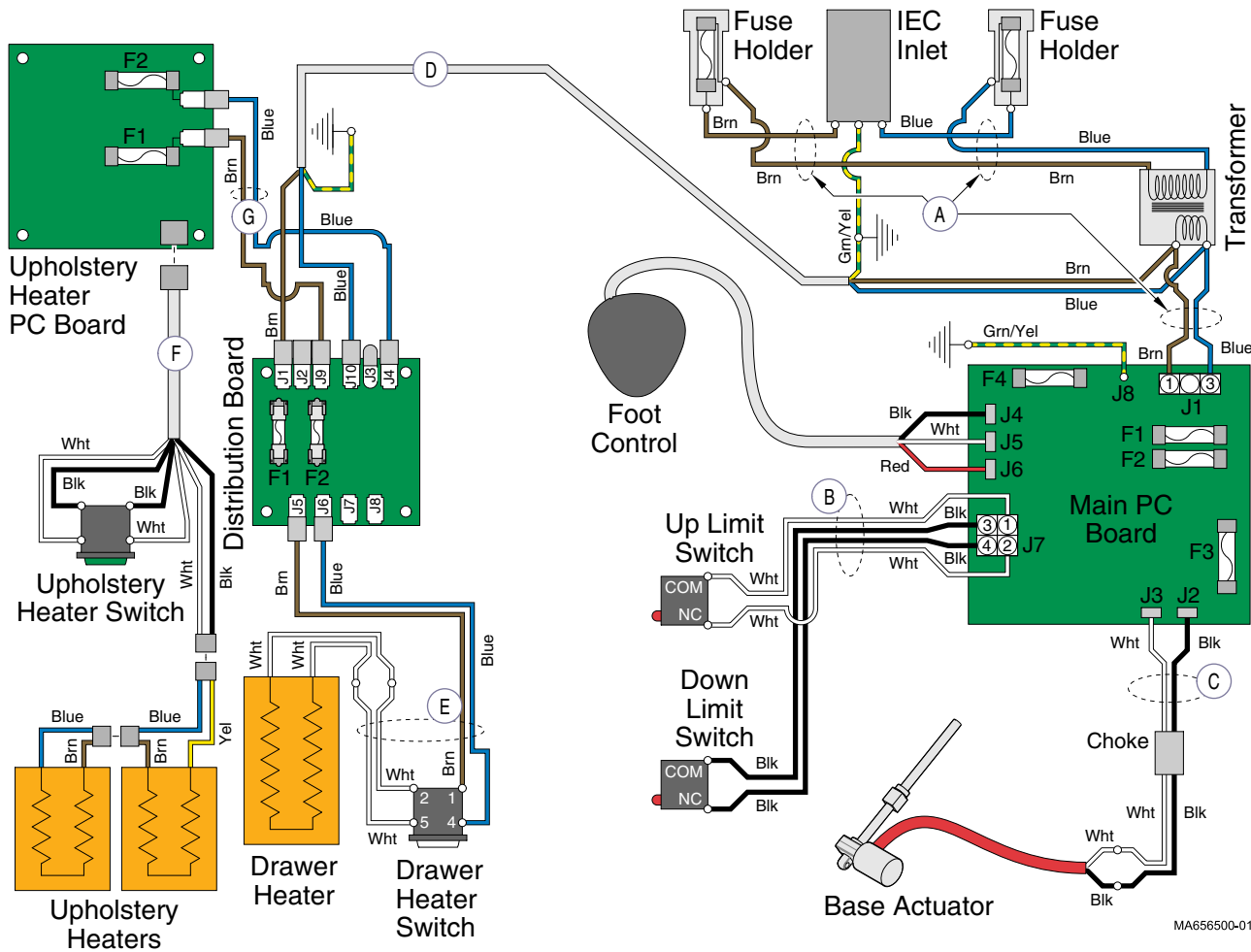

Wire Harness	From:	To:	Part Number
A	IEC Inlet	Main PC Board	015-1580-00 <i>(includes Item B)</i>
B	BaseUp / Down Limit Switches	Main PC Board	015-1580-00 <i>(includes Item A)</i>
C	Base Actuator Wires	Main PC Board	015-1635-00 <i>(includes choke)</i>
D	Distribution Board	IEC Inlet	015-1594-00
E	Heater Plate / Heater Switch	Distribution Board	015-1629-00
F	Upholstery Heater Board	Upholstery Heater, On/Off Switch	015-1722-00
G	Distribution Board	Upholstery Heater Board	015-1720-00

Models: 622 (-004)
Serial Numbers: all

Wiring Diagrams

© Midmark Corporation 2003 SF-1838 Rev.2/13/12

Wiring Diagrams

Refer To: Page
Fuses E-24

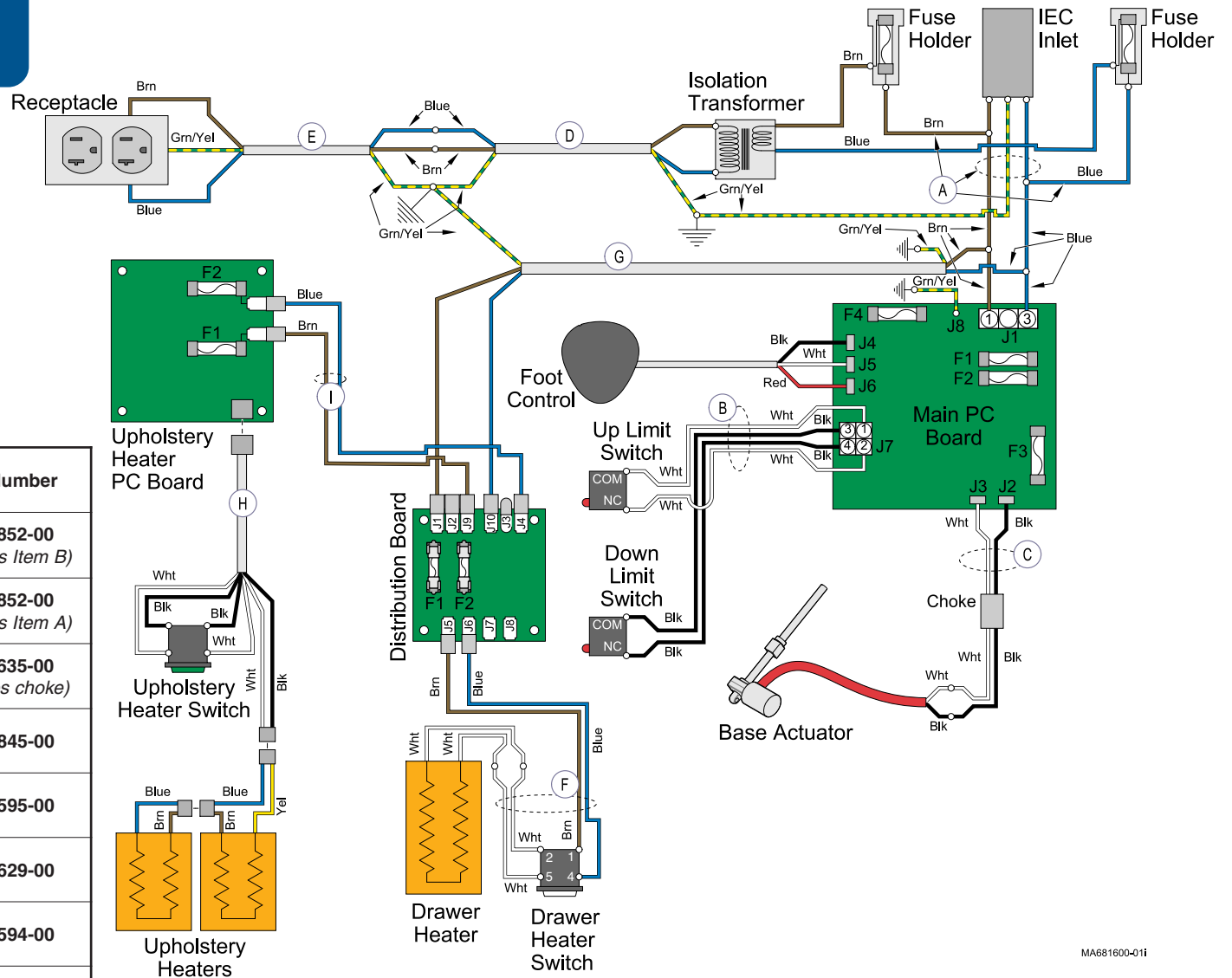

Wire Harness	From:	To:	Part Number
A	IEC Inlet	Main PC Board	015-1852-00 <i>(includes Item B)</i>
B	BaseUp / Down Limit Switches	Main PC Board	015-1852-00 <i>(includes Item A)</i>
C	Base Actuator Wires	Main PC Board	015-1635-00 <i>(includes choke)</i>
D	Isolation Transformer	Item E	015-1845-00
E	Receptacle	Item D	015-1595-00
F	Heater Plate / Heater Switch	Distribution Board	015-1629-00
G	Distribution Board	Item A	015-1594-00
H	Uph. Heater PC Board	Upholstery Heater Switch	015-1722-00
I	Distribution Board	Uph. Heater PC Board	015-1720-00

MA681600-011

Wiring Diagrams

Refer To: Page
Fuses E-24

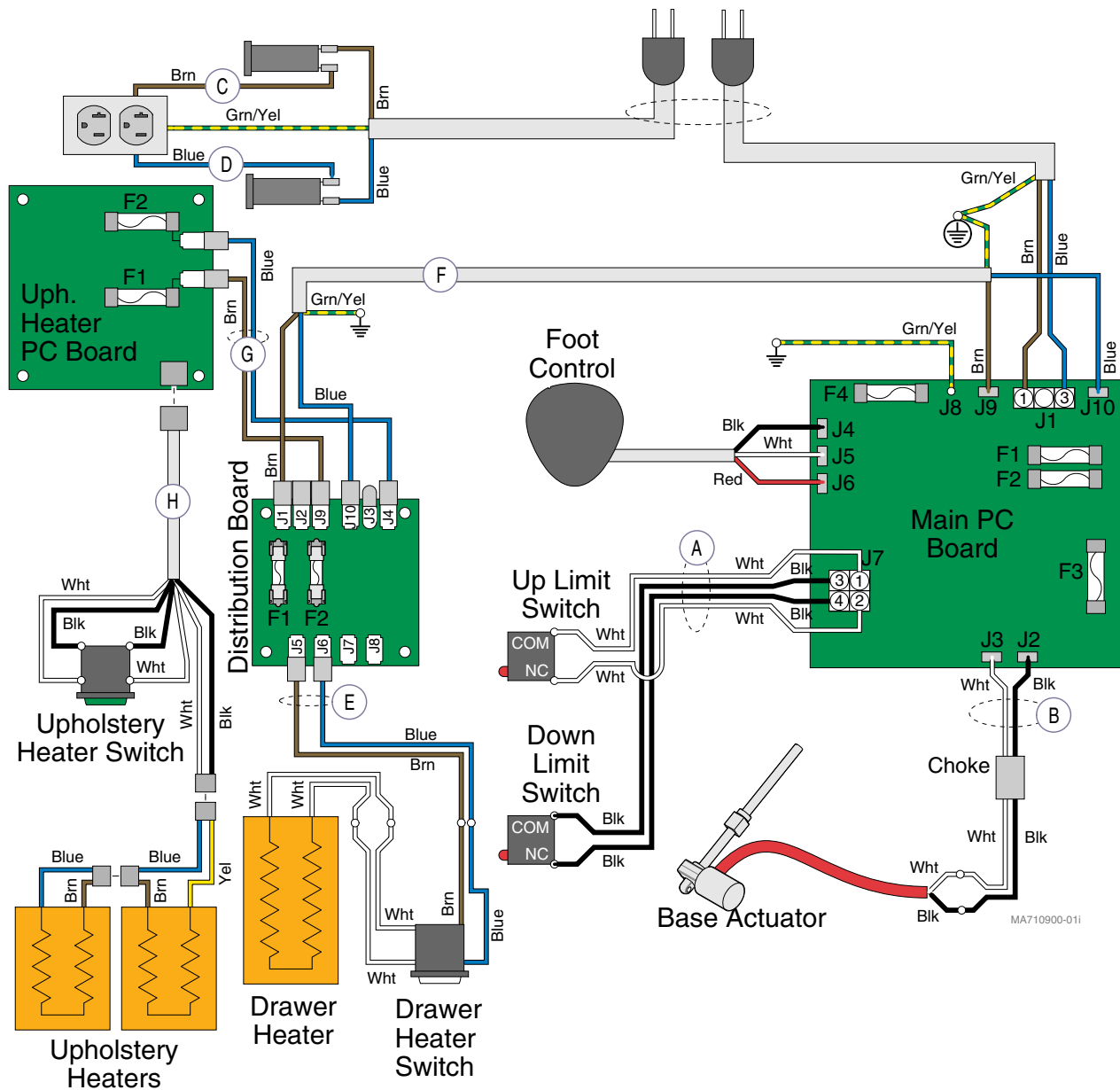

Wire Harness	From:	To:	Part Number
A	BaseUp / Down Limit Switches	Main PC Board	015-2003-00
B	Base Actuator Wires	Main PC Board	015-1635-00 (incl. choke)
C	Circuit Breaker (brown wire)	Table Receptacle	015-1886-00
D	Circuit Breaker (blue wire)	Table Receptacle	015-1886-01
E	Drawer Heater Switch	Distribution Board	015-2004-00
F	Distribution Board	Main PC Board	015-2005-00
G	Distribution Board	Uph. Heater PC Board	015-2006-00
H	Uph. Heater Switch	Uph. Heater PC Board	015-1722-00

Models: 622 (-008)
Serial Numbers: all

Wiring Diagrams

Wiring Diagrams

Refer To: _____ Page
Fuses E-24

Wire Harness	From:	To:	Part Number
A	IEC Inlet	Main PC Board	015-1741-00 <i>(includes Item B)</i>
B	Base & Back Limit Switches	Main PC Board	015-1741-00 <i>(includes Item A)</i>
C	Base Actuator Wires	Main PC Board	015-1635-00 <i>(includes choke)</i>
D	Back Actuator Wires	Main PC Board	015-1635-00 <i>(includes choke)</i>
E	Foot Control Inlet	Main PC Board	015-1784-00
F	Circuit Breaker	IEC Inlet	015-1594-00
G	Receptacle	Circuit Breaker	015-1595-00

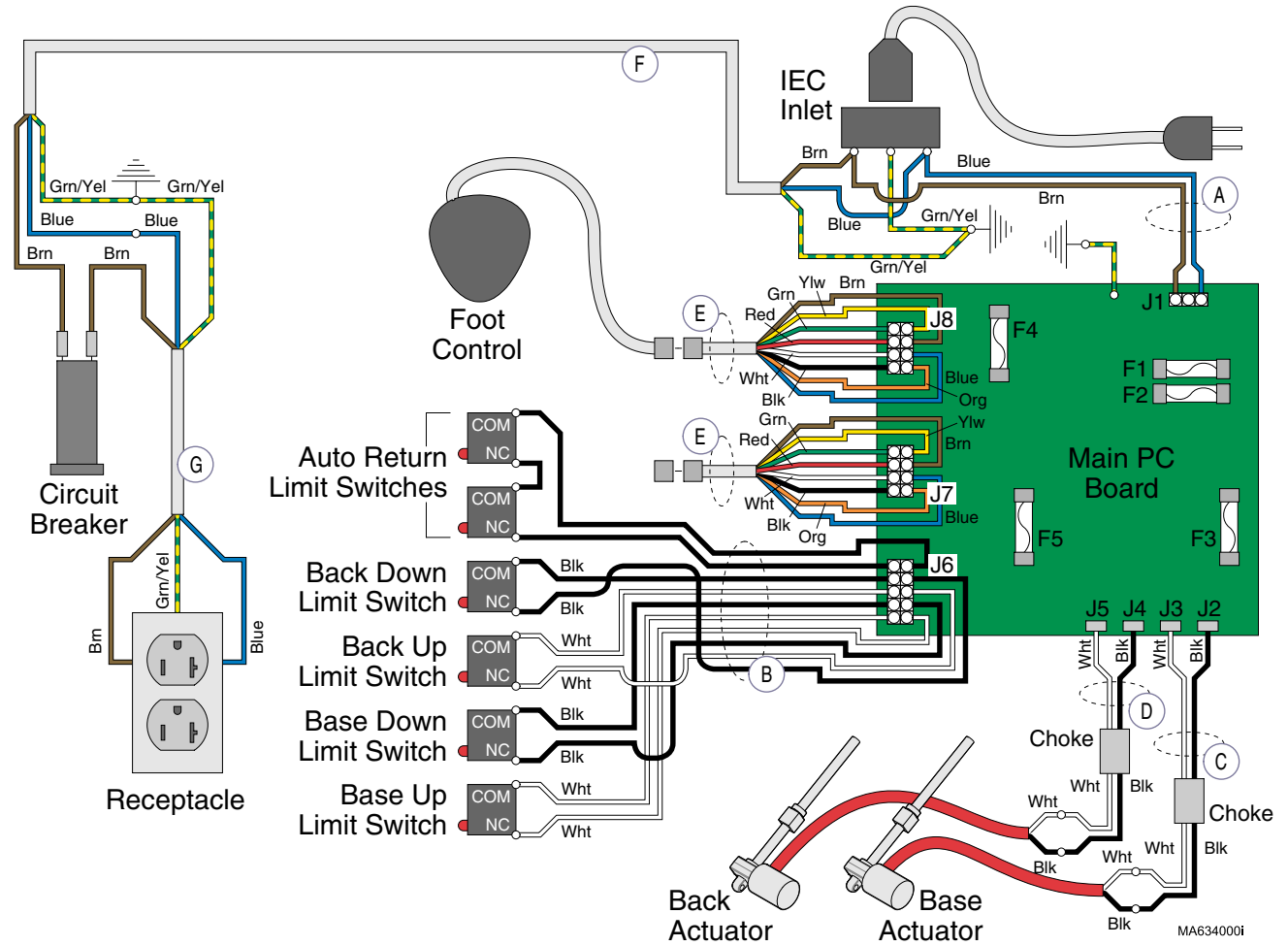

Wiring Diagrams

Refer To: Page
 Fuses E-24

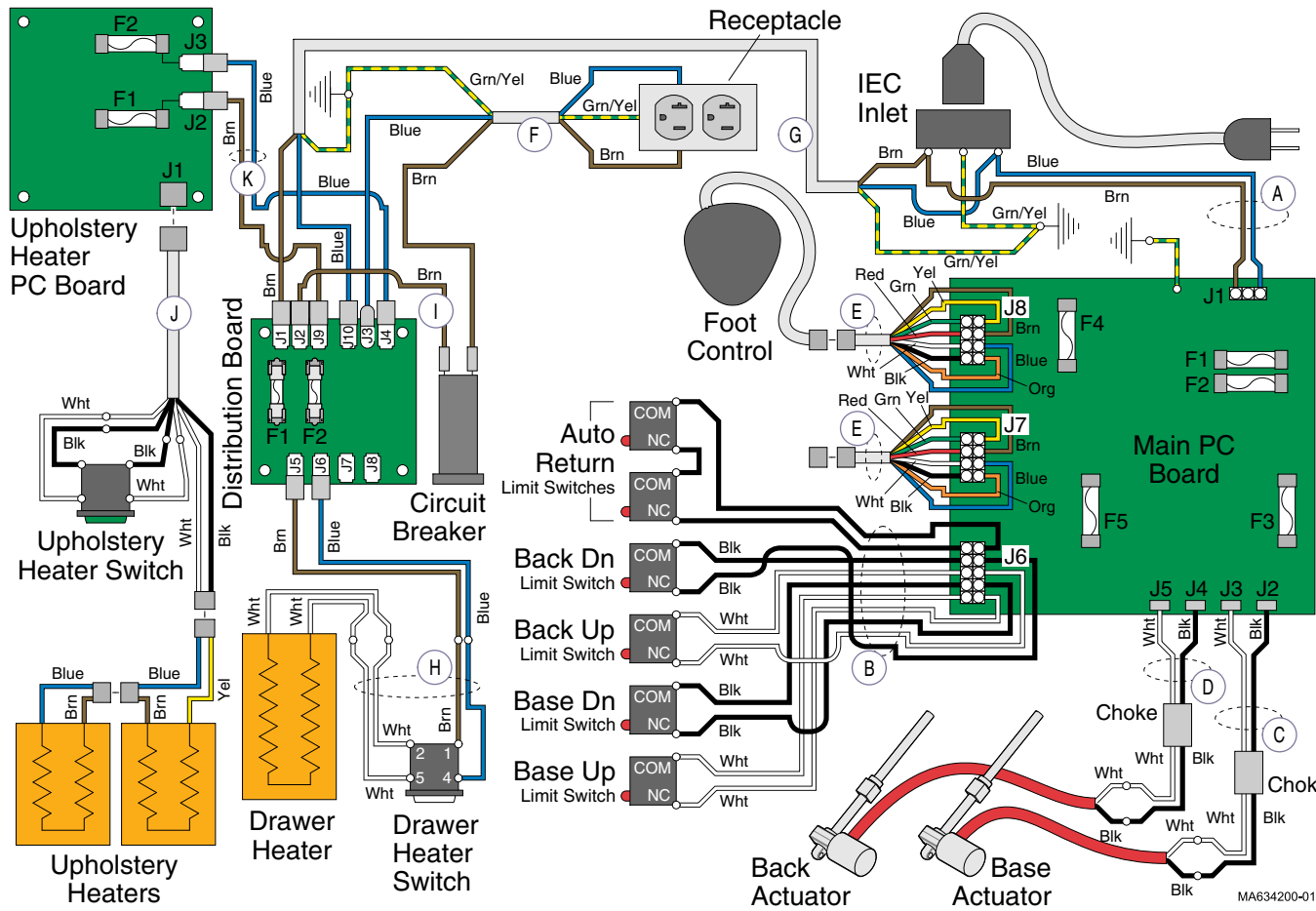

Wire Harness	From:	To:	Part Number
A	IEC Inlet	Main PC Board	015-1741-00 <i>(includes Item B)</i>
B	Base, Back, & Auto Return Limit Switches	Main PC Board	015-1741-00 <i>(includes Item A)</i>
C	Base Actuator Wires	Main PC Board	015-1635-00 <i>(includes choke)</i>
D	Back Actuator Wires	Main PC Board	015-1635-00 <i>(includes choke)</i>
E	Foot Control Inlet	Main PC Board	015-1784-00
F	Receptacle	Circuit Breaker	015-1595-00
G	Distribution Board	IEC Inlet	015-1594-00
H	Heater Plate / Heater Switch	Distribution Board	015-1629-00
I	Circuit Breaker	Distribution Board	015-0708-30
J	Upholstery Heater Board	Upholstery Heater, On/Off Switch	015-1722-00
K	Distribution Board	Upholstery Heater Board	015-1720-00

Models: 623 (-002)
Serial Numbers: all

Wiring Diagrams

Wiring Diagrams

Refer To: Page
Fuses E-24

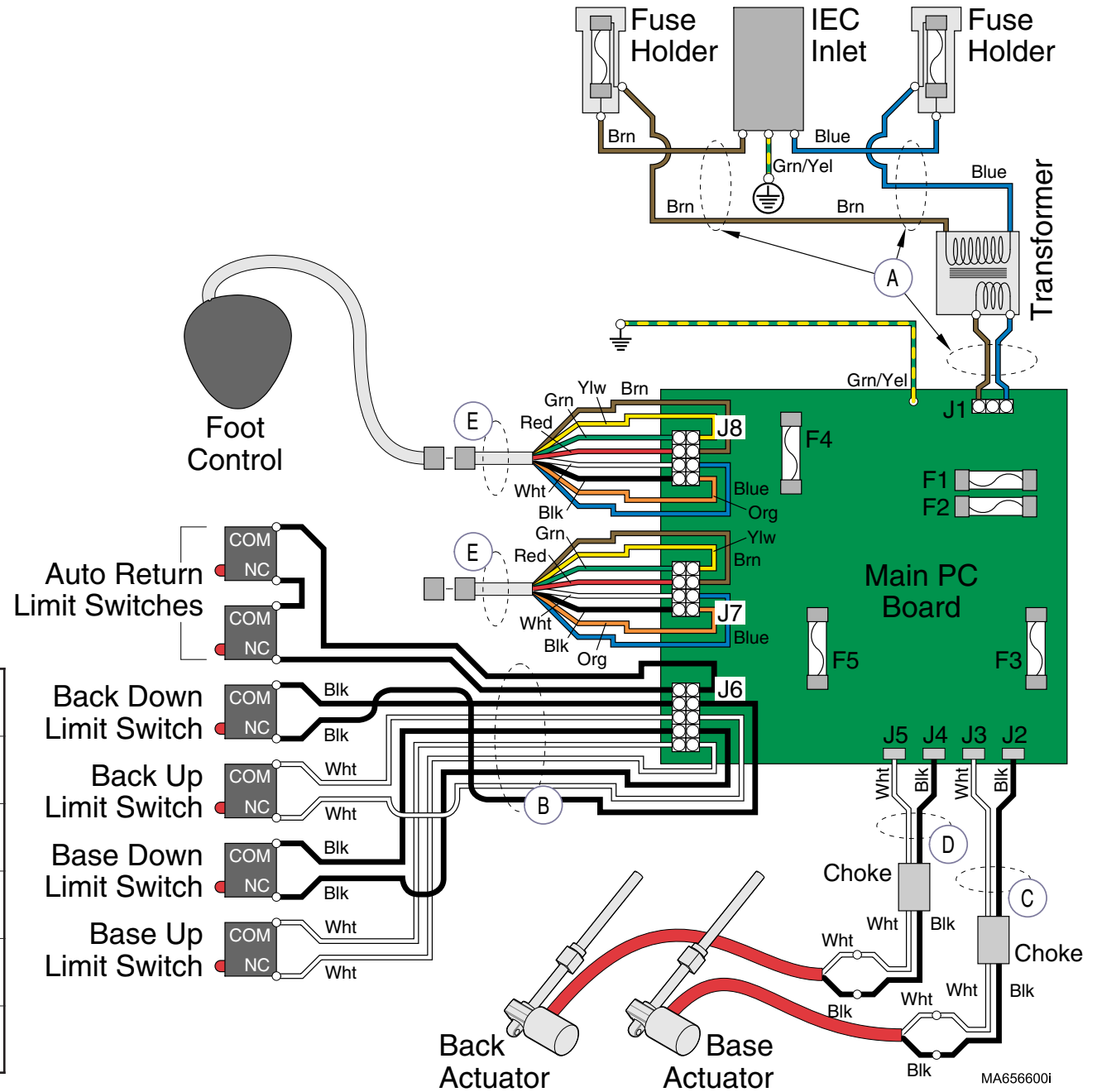

Wire Harness	From:	To:	Part Number
A	IEC Inlet	Main PC Board	015-1809-00 <i>(includes Item B)</i>
B	Base & Back Limit Switches	Main PC Board	015-1809-00 <i>(includes Item A)</i>
C	Base Actuator Wires	Main PC Board	015-1635-00 <i>(includes choke)</i>
D	Back Actuator Wires	Main PC Board	015-1635-00 <i>(includes choke)</i>
E	Foot Control Inlet	Main PC Board	015-1784-00

Wiring Diagrams

Refer To: **Page**
Fuses **E-24**

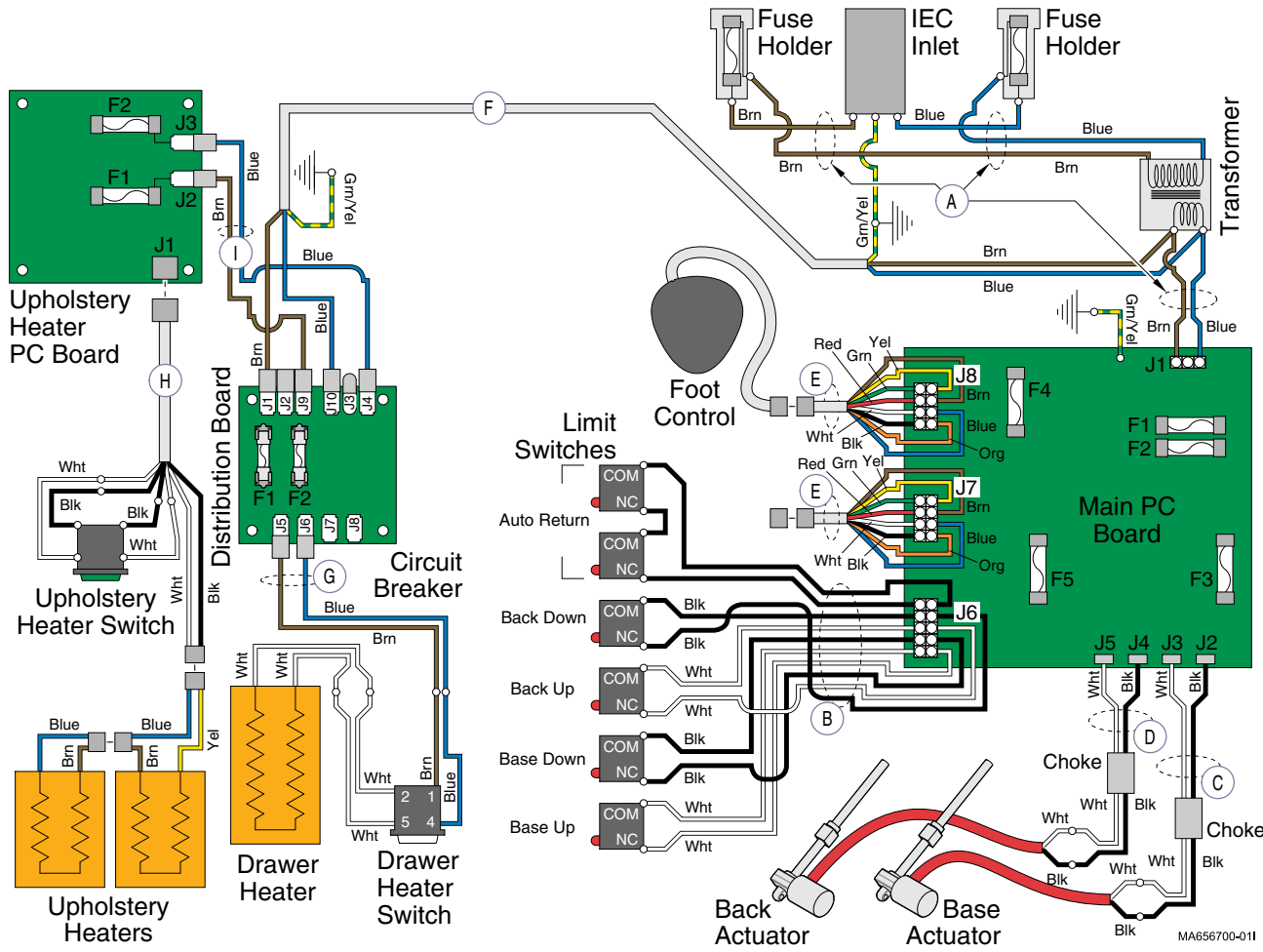

Wire Harness	From:	To:	Part Number
A	IEC Inlet	Main PC Board	015-1809-00 <i>(includes Item B)</i>
B	Limit Switches (all)	Main PC Board	015-1809-00 <i>(includes Item A)</i>
C	Base Actuator Wires	Main PC Board	015-1635-00 <i>(includes choke)</i>
D	Back Actuator Wires	Main PC Board	015-1635-00 <i>(includes choke)</i>
E	Foot Control Inlet	Main PC Board	015-1784-00
F	Distribution Board	IEC Inlet	015-1594-00
G	Drawer Heater Switch	Distribution Board	<i>623-004</i> 015-1629-00 <i>623-0010</i> 015-2004-00
H	Uph. Heater PC Board	Uph. Heater Switch	015-1722-00
I	Distribution Board	Uph. Heater PC Board	<i>623-004</i> 015-1720-00 <i>623-0010</i> 015-2006-00

Models: **623 (-004)** | **623 (-010)**
Serial Numbers: all | V2200 thru V256516

Wiring Diagrams

Wiring Diagrams

Refer To: _____ Page _____
 Fuses E-24

Wire Harness	From:	To:	Part Number
A	IEC Inlet	Main PC Board	015-1809-00 <i>(includes Item B)</i>
B	Limit Switches (all)	Main PC Board	015-1809-00 <i>(includes Item A)</i>
C	Base Actuator Wires	Main PC Board	015-1635-00 <i>(includes choke)</i>
D	Back Actuator Wires	Main PC Board	015-1635-00 <i>(includes choke)</i>
E	Foot Control Inlet	Main PC Board	015-1784-00
F	Distribution Board	IEC Inlet	015-2005-00
G	Drawer Heater Switch	Distribution Board	623-004 015-1629-00 623-0010 015-2004-00
H	Uph. Heater PC Board	Uph.Heater Switch	015-1722-00
I	Distribution Board	Uph. Heater PC Board	623-004 015-1720-00 623-0010 015-2006-00

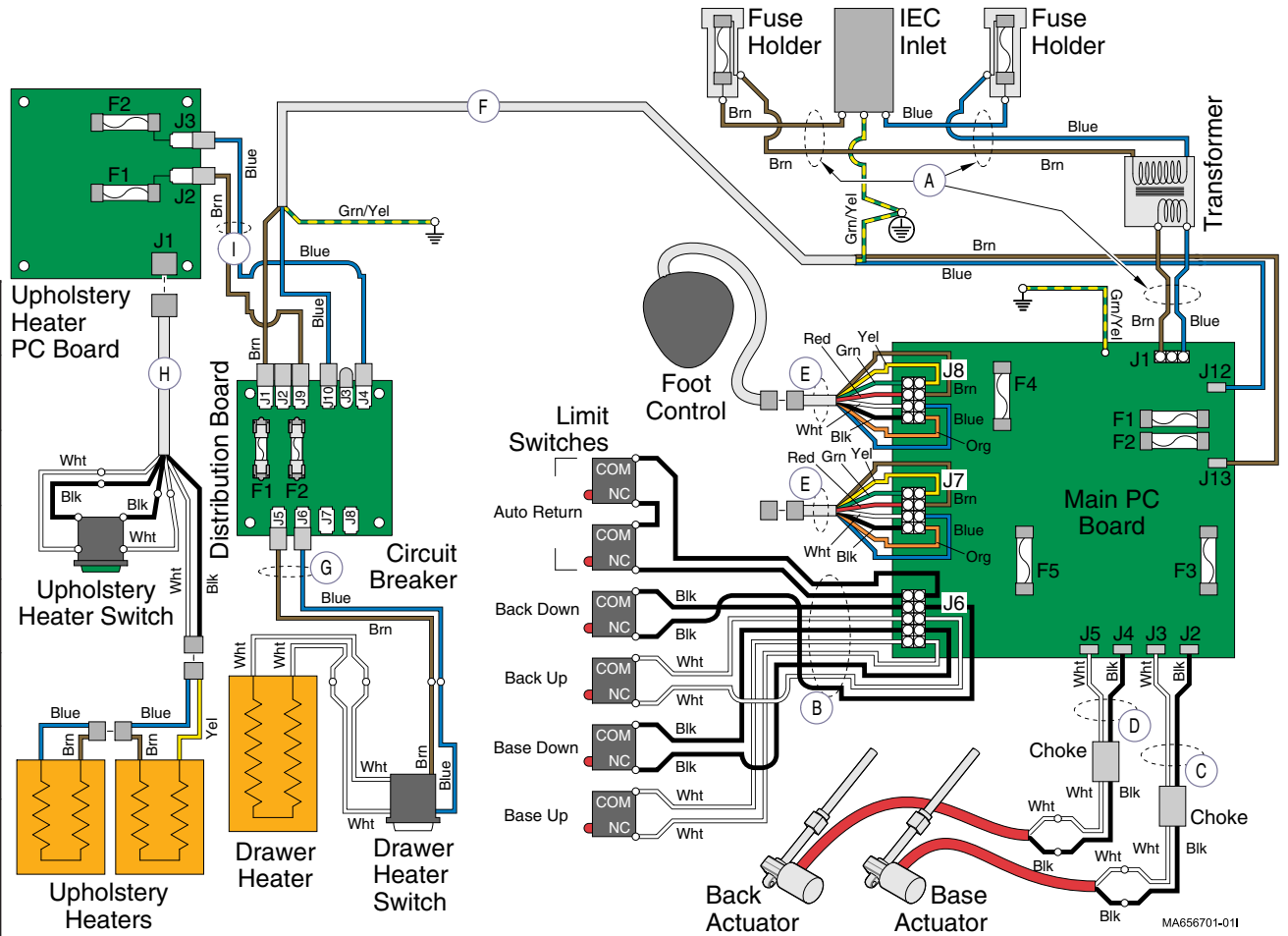

Wiring Diagrams

Refer To: Page
 Fuses E-24

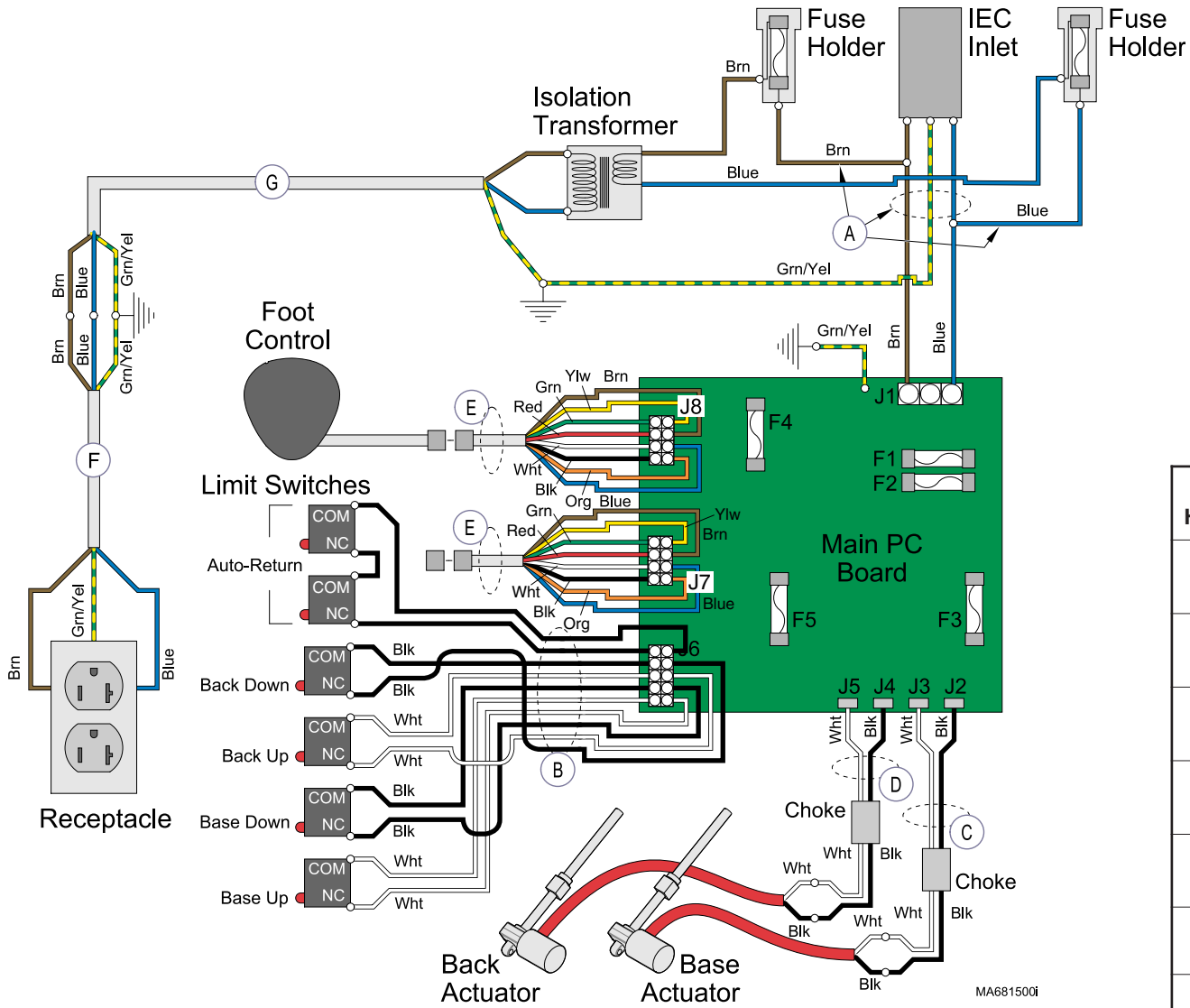

Wire Harness	From:	To:	Part Number
A	IEC Inlet	Main PC Board	015-1854-00 <i>(includes Item B)</i>
B	Base & Back Limit Switches	Main PC Board	015-1854-00 <i>(includes Item A)</i>
C	Base Actuator Wires	Main PC Board	015-1635-00 <i>(includes choke)</i>
D	Back Actuator Wires	Main PC Board	015-1635-00 <i>(includes choke)</i>
E	Foot Control Inlet	Main PC Board	015-1784-00
F	Receptacle	Item G	015-1595-00
G	Isolation Transformer	Item F	015-1845-00

Models: 623 (-005)
Serial Numbers: all

Wiring Diagrams

Wiring Diagrams

Refer To:

Page

Fuses

E-24

Wire Harness	From:	To:	Part Number
A	IEC Inlet	Main PC Board	015-1854-00 <i>(includes Item B)</i>
B	Limit Switches (all)	Main PC Board	015-1854-00 <i>(includes Item A)</i>
C	Base Actuator Wires	Main PC Board	015-1635-00 <i>(includes choke)</i>
D	Back Actuator Wires	Main PC Board	015-1635-00 <i>(includes choke)</i>
E	Foot Control Inlet	Main PC Board	015-1784-00
F	Distribution Board	Item A	015-1594-00
G	Isolation Transformer	Item H	015-1845-00
H	Receptacle	Item G	015-1595-00
I	Uph. Heater PC Board	Upholstery Heater Switch	015-1722-00
J	Drawer Heater Plate / Switch	Distribution Board	015-1629-00
K	Distribution Board	Uph. Heater PC Board	015-1720-00

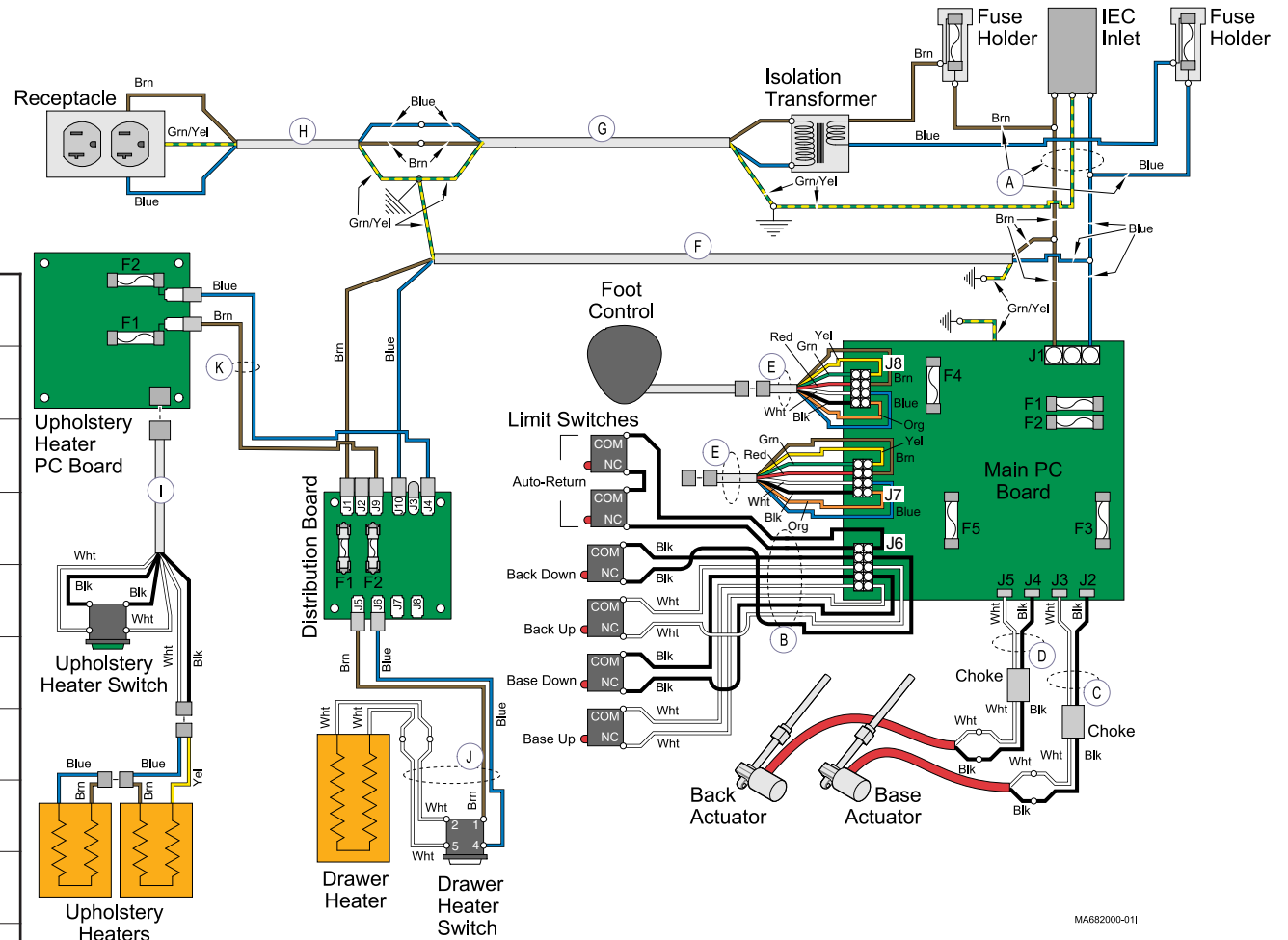

MA682000-011

Wiring Diagrams

Refer To: _____ **Page** _____
Fuses E-24

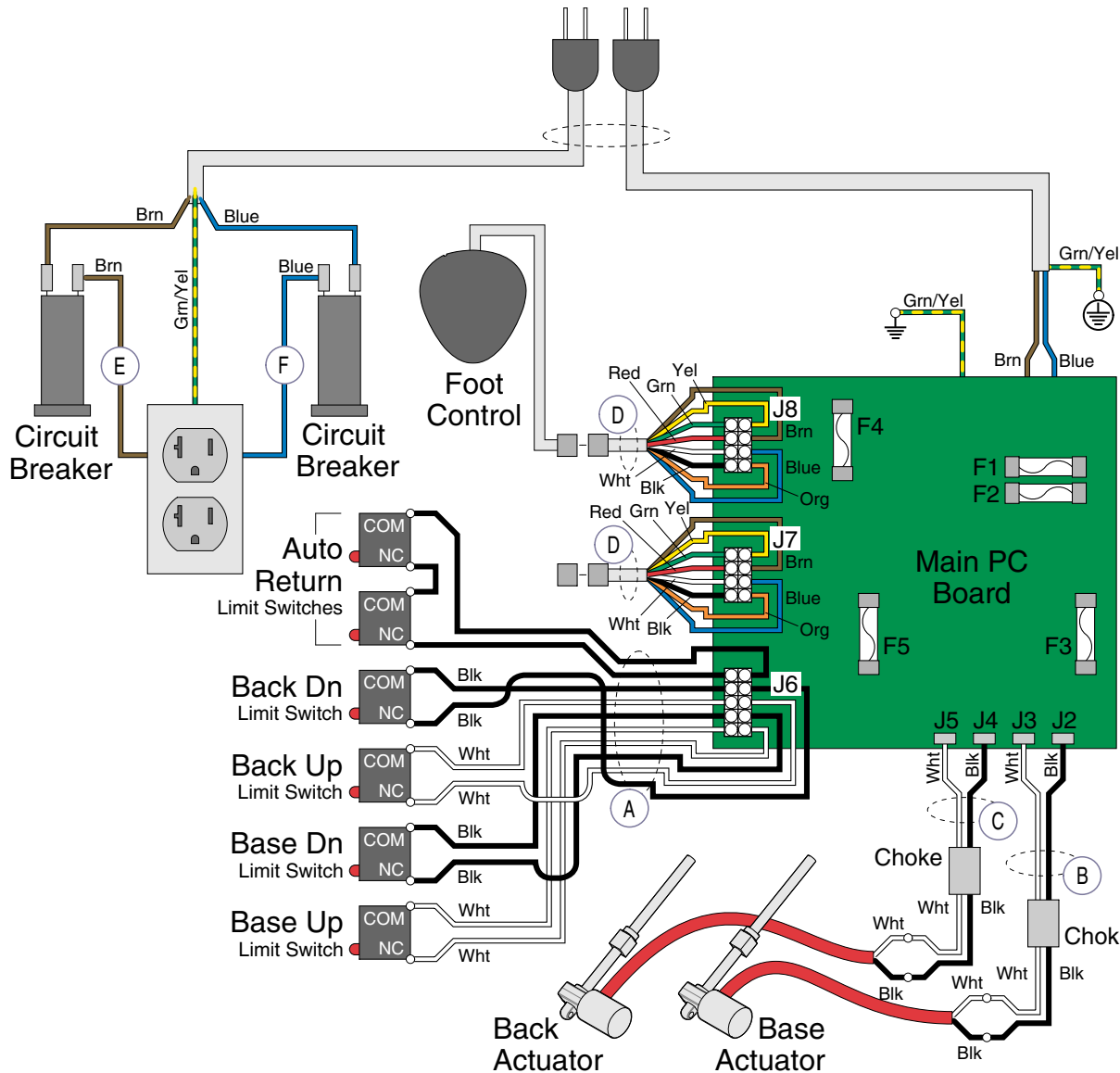

Wire Harness	From:	To:	Part Number
A	Limit Switches (all)	Main PC Board	015-2008-00
B	Base Actuator Wires	Main PC Board	015-1635-00 (includes choke)
C	Back Actuator Wires	Main PC Board	015-1635-00 (includes choke)
D	Foot / Hand Control Port	Main PC Board	015-1784-00
E	Circuit Breaker (brown wire)	Table Receptacle	015-1886-00
F	Circuit Breaker (blue wire)	Table Receptacle	015-1886-01

Models: 623 (-007)
Serial Numbers: all

Wiring Diagrams

© Midmark Corporation 2003 SF-1838 Rev. 11/11

Wiring Diagrams

Refer To: _____ Page
Fuses E-24

Wire Harness	From:	To:	Part Number
A	Limit Switches (all)	Main PC Board	015-2008-00
B	Base Actuator Wires	Main PC Board	015-1635-00 <i>(includes choke)</i>
C	Back Actuator Wires	Main PC Board	015-1635-00 <i>(includes choke)</i>
D	Foot Control Inlet	Main PC Board	015-1784-00
E	Circuit Breaker <i>(brown wire)</i>	Table Receptacle	015-1886-00
F	Circuit Breaker <i>(blue wire)</i>	Table Receptacle	015-1886-01
G	Distribution Board	Main PC Board	015-2005-00
H	Uph. Heater PC Board	Upholstery Heater Switch	015-1722-00
I	Drawer Heater Switch	Distribution Board	015-2004-00
J	Distribution Board	Uph. Heater PC Board	015-2006-00

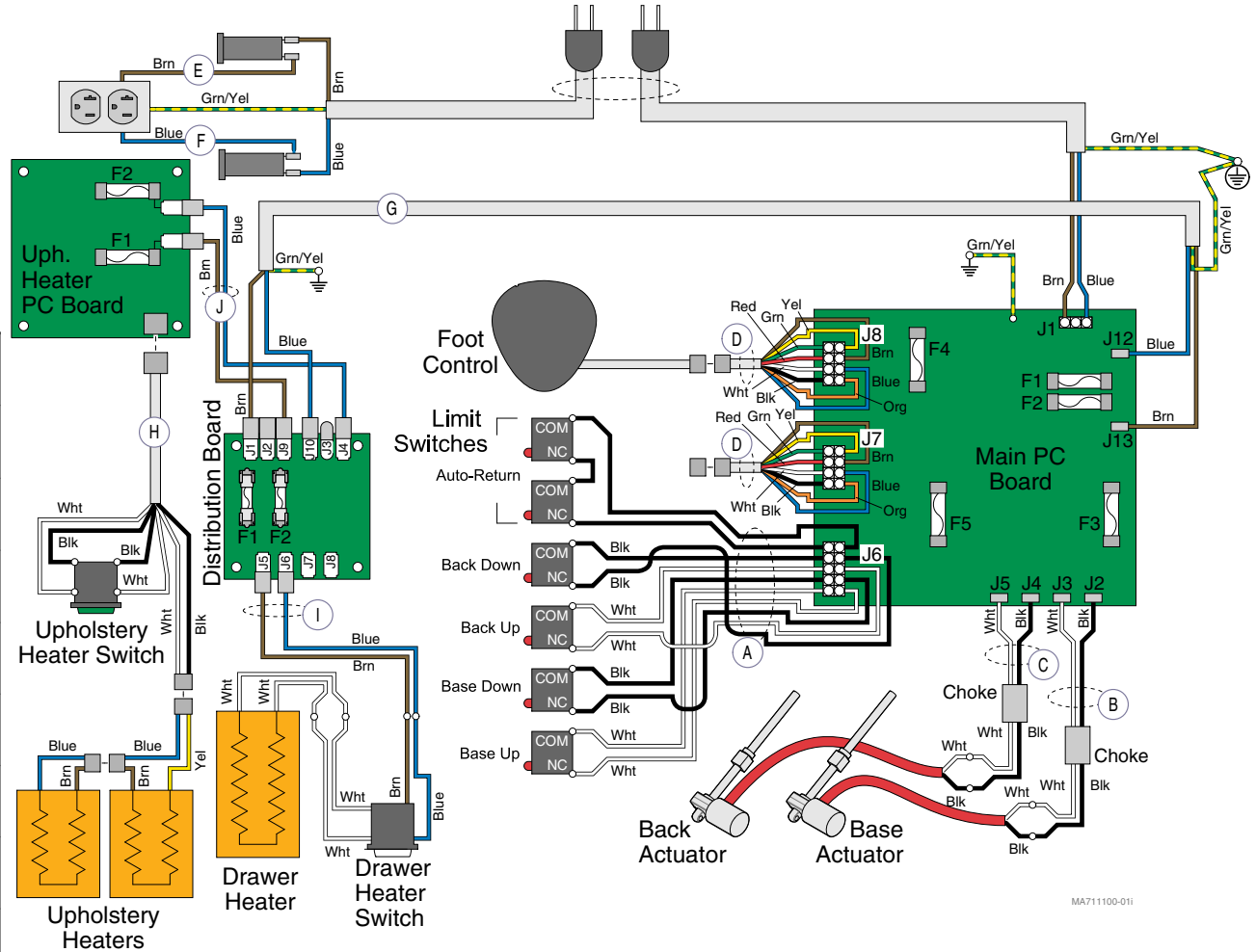

MA711100-01

Upholstery - Ritter:
Soft Touch E-6*
Seamless E-7*

includes:
 footrest pad, paper roll holder,
 handles, etc.

**Ritter Upperwrap
 & Footrest Shelf** E-15*

includes:
 footrest shelf, stirrup guide,
 treatment pan, etc.

Stirrups E-17

**Exam Assistant
 Drawer Assy.** E-25

Foot Control:
 222 / 622 E-26

**Base
 Actuator** E-21

Fuses (all) E-24

PC Board Enclosure:
 Manual Back Models E-22

includes:
 PC Board, cover, mtg hardware

Optional Features
Drawer Heater E-30*
Pelvic Tilt E-31*
Table Receptacle E-33*
Transformer / Fuses:
 230 VAC Models E-35
 Canadian Models E-34

**Manual Back
 Components** E-10*

includes:
 gas spring, top cover, handles,
 release mechanism, etc.

**Base Scissor /
 Slide Mechanism** E-18*

**Ritter Base
 Components** E-19*

includes:
 power cord, base slides
 base limit switches, etc.

**Label
 Location** E-37

Table Shrouds:
 Ritter Models E-13*

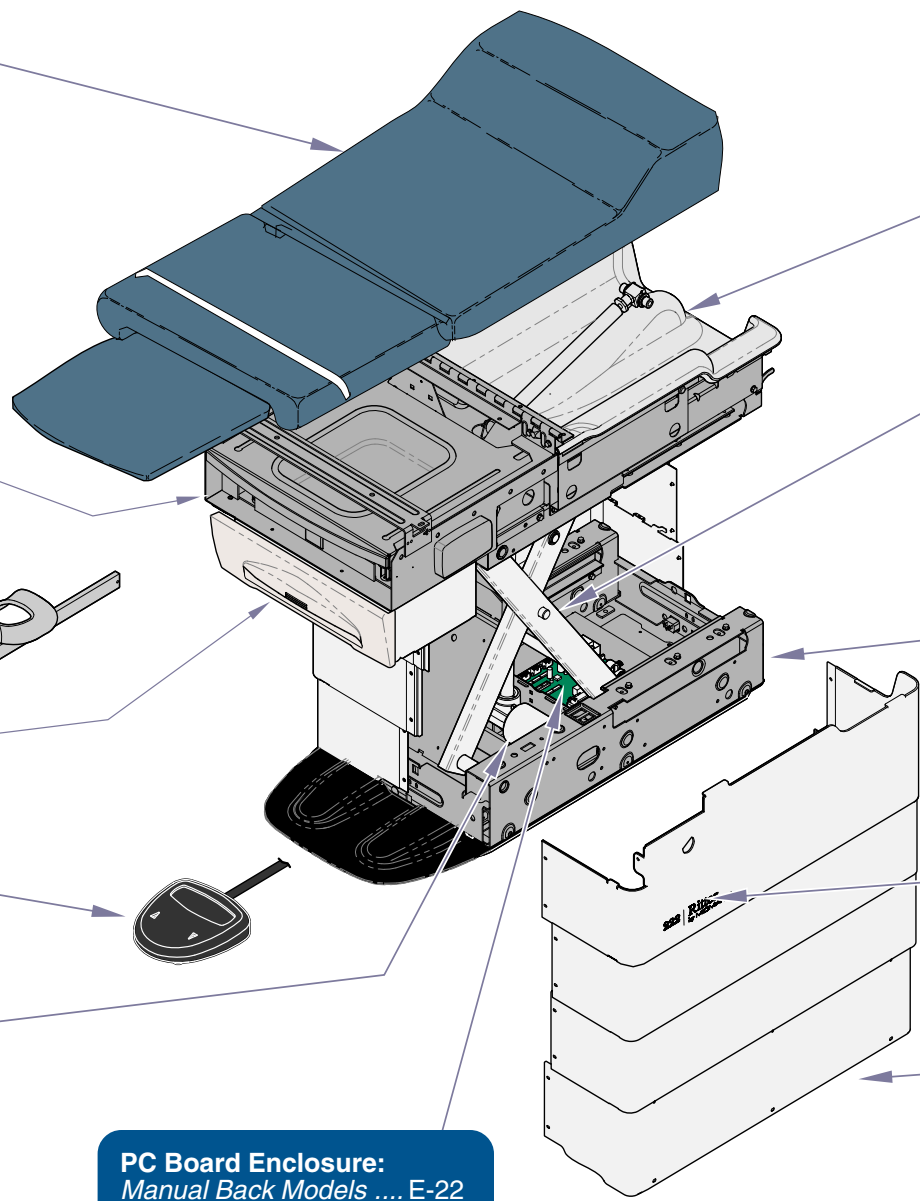

MA715300i

Optional Features

Drawer Heater E-30*
Pelvic Tilt E-31*
Transformer / Fuses:
 230 VAC Models E-35
 Canadian Models E-34

Upholstery - Ritter:

Soft Touch E-6*
Seamless E-7*

includes:
 footrest pad, paper roll holder,
 handles, etc.

Ritter Upperwrap & Footrest Shelf E-15.1*

includes:
 footrest shelf, stirrup guide,
 treatment pan, etc.

Stirrups E-17

Exam Assistant Drawer Assy. E-25

Table Receptacle System E-33*

Foot Control: 223 E-27*

Base Actuator. E-21

Hand Control E-29* (Optional)

PC Board Enclosure: Power Back Models E-23

includes:
 PC Board, cover, mtg hardware

Power Back Components E-11*

includes:
 limit switches, top cover, etc.

Back Actuator E-12

Base Scissor / Slide Mechanism E-18.2*

Ritter Base Components E-19.2*

includes:
 power cord, base slides
 base limit switches, etc.

Label Location E-37

Table Shrouds: Ritter Models E-13.1*

Fuses (all) E-24

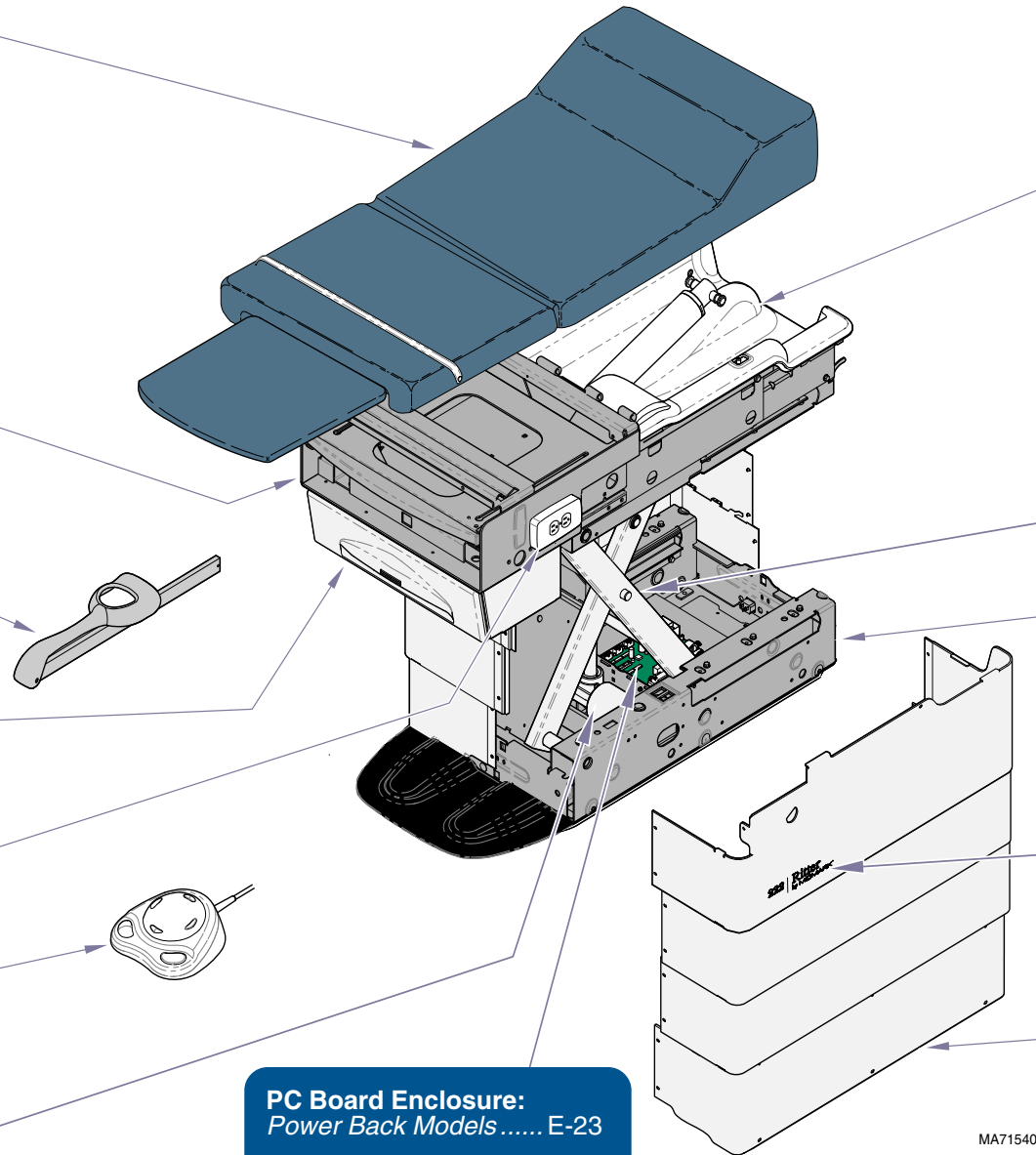

* Indicates multiple pages due to a model / serial number break for the parts illustration

Upholstery - Midmark:
 Premium E-8*
 Ultra-Premium E-9*

includes:
 footrest pad, paper roll holder,
 handles, etc.

**Midmark Upperwrap
 & Footrest Shelf E-16***

includes:
 footrest shelf, stirrup guide,
 treatment pan, etc.

Stirrups..... E-17

**Exam Assistant
 Drawer Assy. E-25**

**Foot Control:
 222 / 622 E-26**

**Table Receptacle
 System E-33***

**Base
 Actuator..... E-21**

Storage Pod E-36

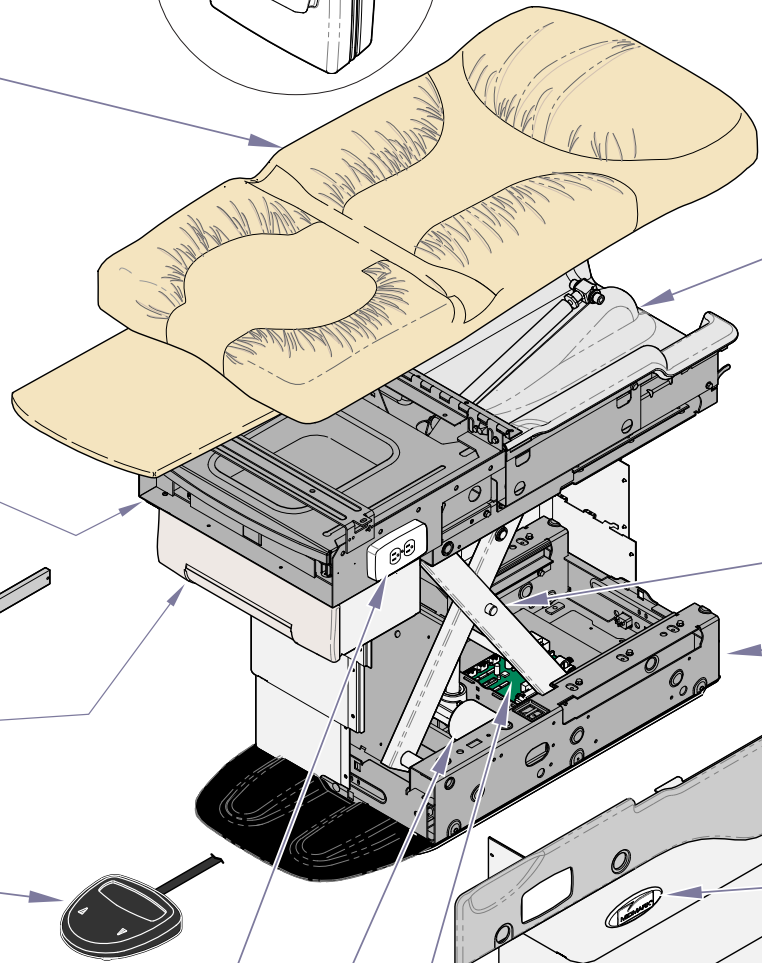
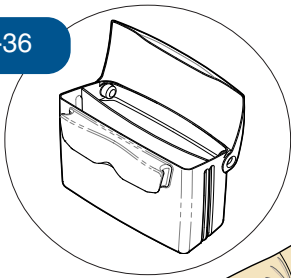

Optional Features
 Drawer Heater E-30*
 Pelvic Tilt E-31*
 Upholstery Heater E-32
Transformer / Fuses:
 230 VAC Models E-35
 Canadian Models E-34

**Manual Back
 Components E-10***

includes:
 gas spring, top cover, handles,
 release mechanism, etc.

**Base Scissor /
 Slide Mechanism E-18.2***

**Midmark Base
 Components E-20***

includes:
 power cord, base slides
 base limit switches, etc.

**Label
 Location E-37**

**Table Shrouds:
 Midmark Models E-14***

**PC Board Enclosure:
 Manual Back Models E-22**

includes:
 PC Board, cover, mtg hardware

MA715500i

Fuses (all) E-24

623

Storage Pod E-36

Hand Control E-29*

Upholstery - Midmark:
 Premium E-8*
 Ultra-Premium E-9*

includes:
 footrest pad, paper roll holder,
 handles, etc.

**Midmark Upperwrap
 & Footrest Shelf E-16***

includes:
 footrest shelf, stirrup guide,
 treatment pan, etc.

Stirrups E-17

Exam Assistant
 Drawer Assy. E-25

Foot Control:
 623 E-28*

**Base
 Actuator E-21**

Fuses (all) E-24

PC Board Enclosure:
 Power Back Models E-23

includes:
 PC Board, cover, mtg hardware

Optional Features

Drawer Heater E-30*
 Pelvic Tilt E-31*
 Table Receptacle E-33*
 Upholstery Heater E-32
Transformer / Fuses:
 230 VAC Models E-35
 Canadian Models E-34

**Power Back
 Components E-11***

includes:
 limit switches, top cover, etc.

Back Actuator E-12

**Base Scissor /
 Slide Mechanism E-18.2***

**Midmark Base
 Components E-20.1***

includes:
 power cord, base slides
 base limit switches, etc.

**Label
 Location E-37**

Table Shrouds:
 Midmark Models E-14*

MA715600i

* Indicates multiple pages due to a model / serial number break for the parts illustration

Refer To:
Color Selector www.midmark.com

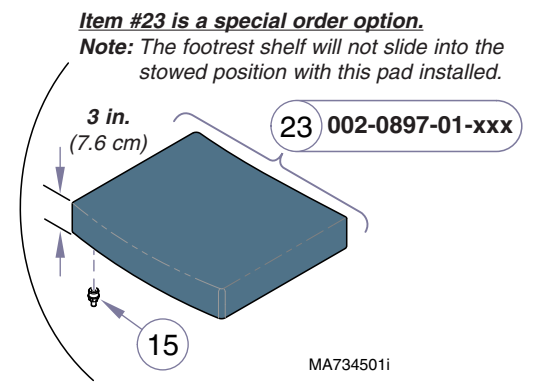
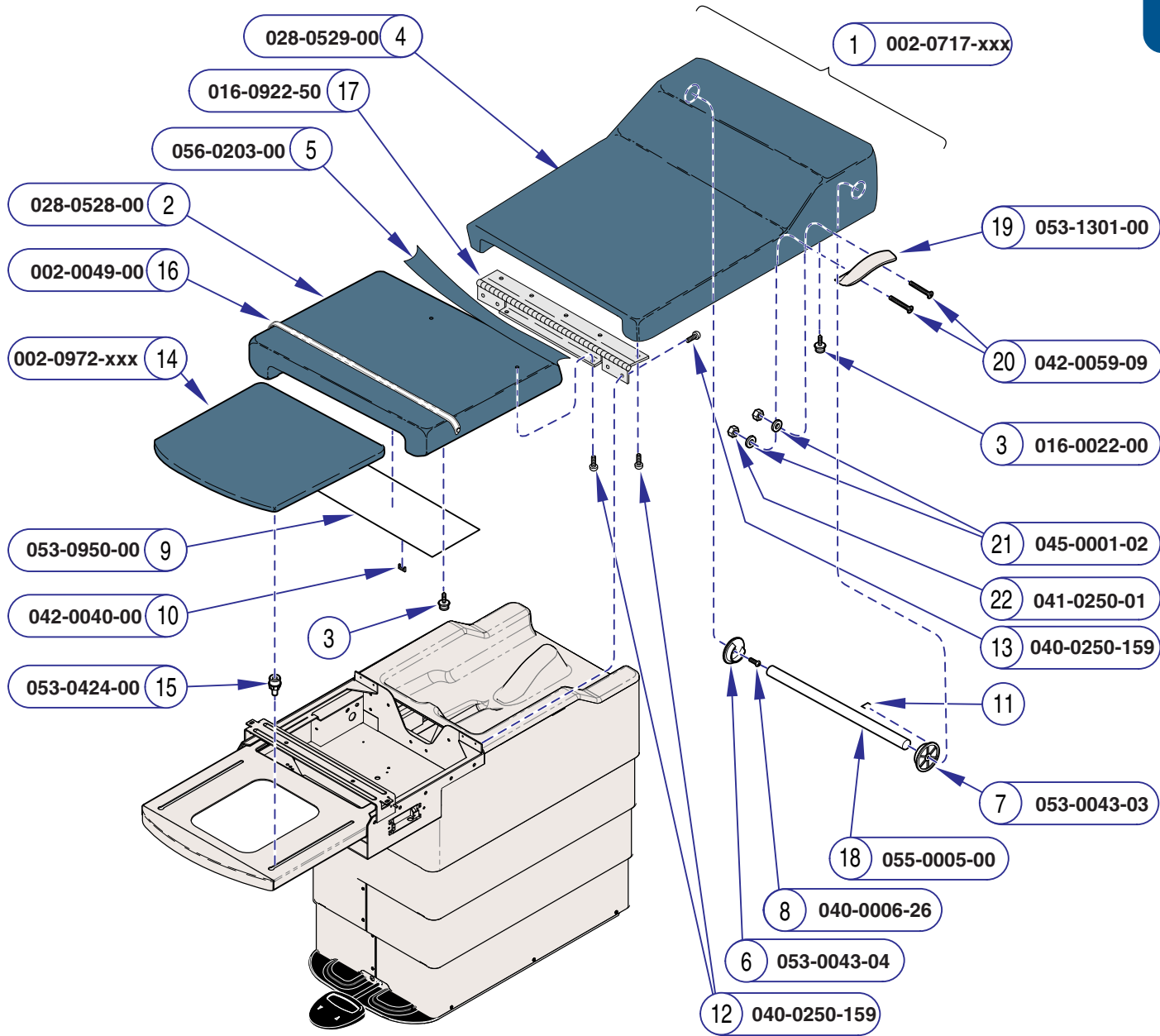

ATTENTION: Refer to *Color Selector* link for appropriate numbers to replace -xxx.

Item	Description	Qty.
1	Cut & Sewn Upholstery Kit 1 <i>(includes items 2 thru 13)</i>	1
2	• Upholstered Seat w/Stud <i>(specify color)</i> ...	1
3	• • Stud	4
4	• Upholstered Headboard w/Stud <i>(specify color)</i>	1
5	• Hinge Cover <i>(specify color)</i>	1
6	• R.H. Dowel Socket	1
7	• L.H. Dowel Socket	1
8	• Screw (#6 x .5")	2
9	• Scuff Plate	1
10	• Staple	10
11	• Staple	AR
12	• Screw	4
13	• Screw (1/4-20 x .87")	8
14	Upholstered Footrest <i>(specify color)</i>	1
15	Footrest Glide	4
16	Tear Straps Kit <i>(includes two straps)</i>	1
17	Hinge Assembly	1
18	Dowel Rod	1
19	Release Handle Grip <i>(222 only)</i>	2
20	Screw (1/4-20 x 1.75" <i>[222 only]</i>)	4
21	Washer <i>(222 only)</i>	4
22	Nut (1/4-20 <i>[222 only]</i>)	4
23	Footrest Pad - special (3 in. thick) <i>[includes four glides (item #15)]</i>	1

Always Specify Model & Serial Number

MA588606i

Upholstery - Ritter
(Soft Touch)

Models: 222 (-001 thru -004, -011, -012)
Serial Numbers: All

223 (-001 thru -004, -011, -012)
All

Refer To:
Color Selector www.midmark.com

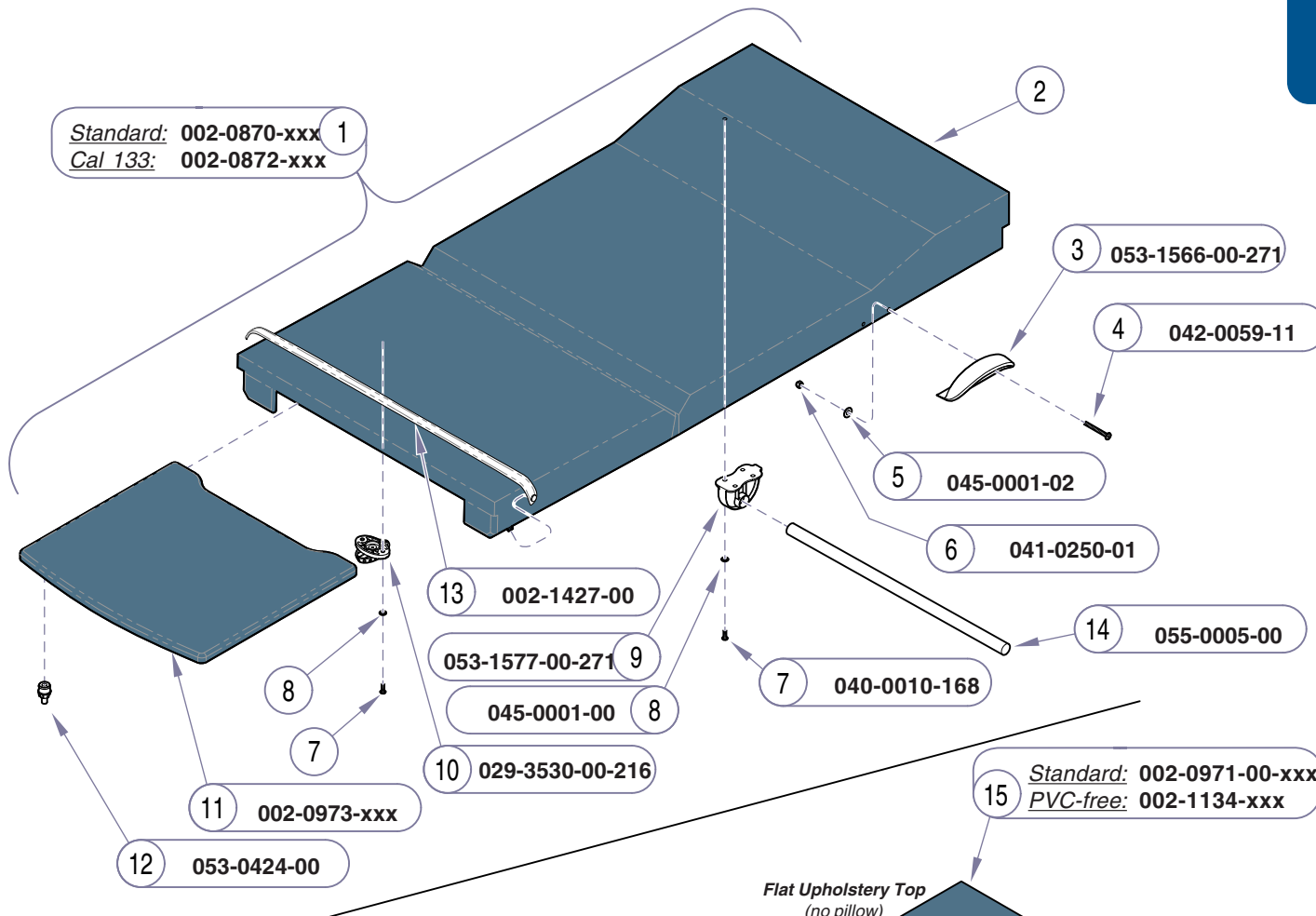

Standard: 002-0870-xxx 1
Cal 133: 002-0872-xxx

3 053-1566-00-271

4 042-0059-11

5 045-0001-02

6 041-0250-01

14 055-0005-00

13 002-1427-00

053-1577-00-271 9

045-0001-00 8

10 029-3530-00-216

7 040-0010-168

11 002-0973-xxx

12 053-0424-00

15 Standard: 002-0971-00-xxx
PVC-free: 002-1134-xxx

Items #15 & 16 are special order options.

Note: The footrest shelf will not slide into the stowed position with item #16 installed.

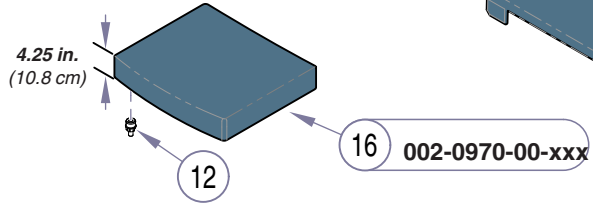

ATTENTION: Refer to *Color Selector* link for appropriate numbers to replace -xxx.

Item	Description	Qty.
1	Upholstery Set (includes items 2 thru 12) ..	1
2	• Seat/Back Upholstery	1
3	• Handle	2
4	• Screw	4
5	• Washer	4
6	• Nylock Nut	4
7	• Screw (10-24 x 5/8")	16
8	• Washer (early models only)	16
9	• Paper Roll Bracket	2
10	• Locking Knob	6
11	• Footrest Pad	1
12	• Footrest Glide	4
13	Tear Strap	1
14	Dowel Rod	1
15	Flat Upholstery Top (includes items 3 thru 10)	1
16	Footrest Pad - special (4.25 in. thick) [includes four glides (item #12)]	1

Always Specify Model & Serial Number

MA705501i

Models: 222 (-015 thru -017) | 223 (-015 & -016)
Serial Numbers: All | All

Upholstery - Ritter
(Soft Touch)

Refer To:
Color Selector www.midmark.com

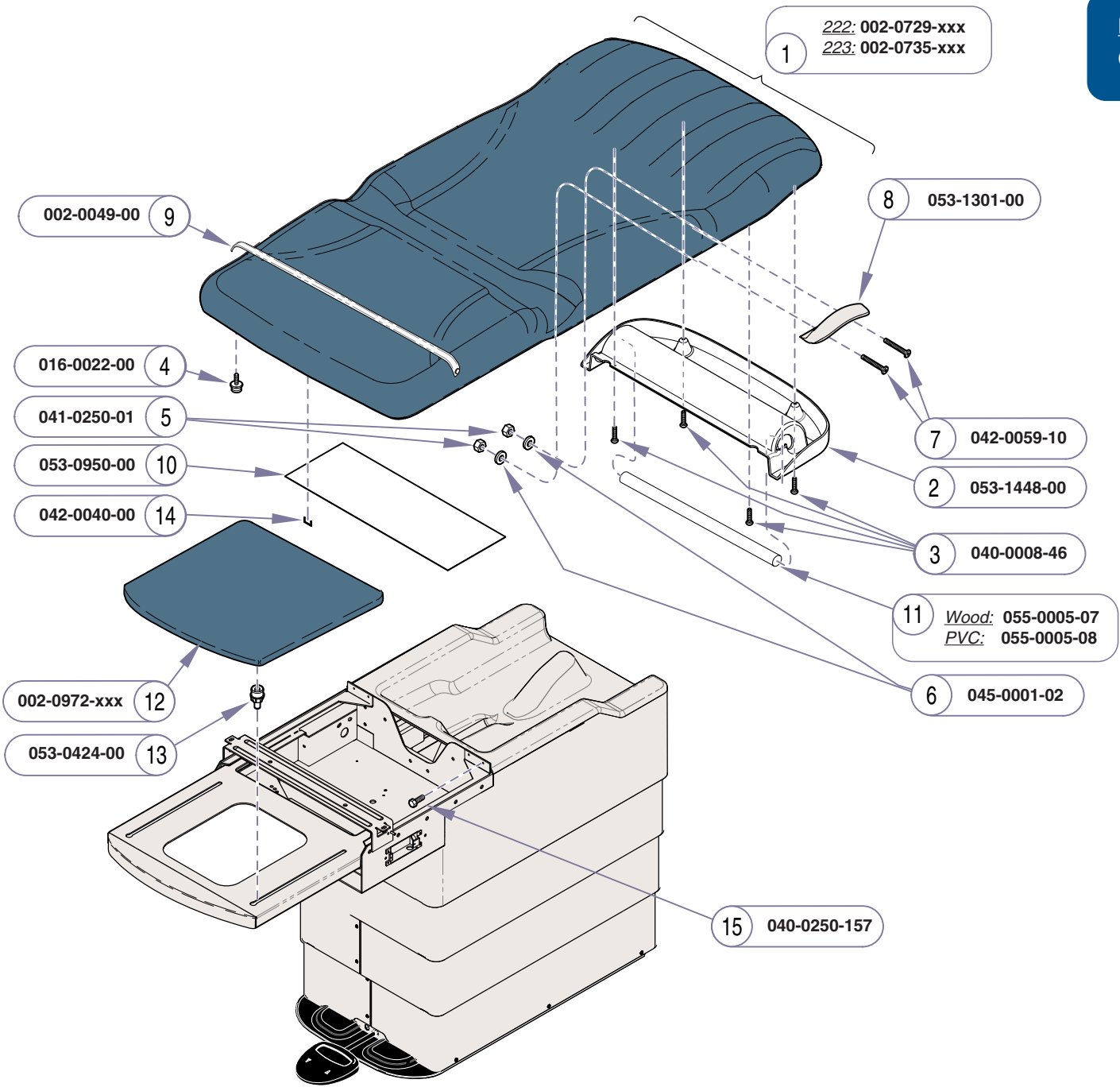

Item #16 is a special order option.

Note: The footrest shelf will not slide into the stowed position with this pad installed.

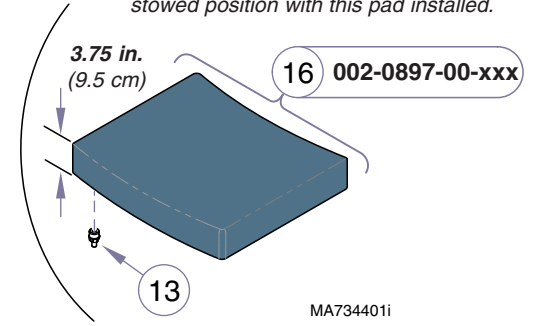

ATTENTION: Refer to *Color Selector* link for appropriate numbers to replace -xxx.

Item	Description	Qty.
1	Seamless Upholstery Top: 222 (includes items 2 thru 8)	1
	223 (includes items 2 thru 4)	1
2	• Paper Roll Holder	1
3	• Screw	4
4	• Stud	2
5	• Nut (222 only)	4
6	• Washer (222 only)	4
7	• Bolt (222 only)	4
8	• Release Handle Grip (222 only)	2
9	Tear Strap Kit	1
10	Scuff Plate	1
11	Dowel Rod	1
12	Upholstered Footrest (specify color)	1
13	Footrest Guide	4
14	Staple	10
15	Bolt	4
16	Footrest Pad - special (3.75 in. thick) [includes four glides (item #13)]	1

Always Specify Model & Serial Number

MA618505

Upholstery - Ritter
(Seamless)

Models: 222 (-005 thru -010, -013, -014)
Serial Numbers: All

223 (-005 thru -010, -013, -014)
All

Refer To:
Color Selector www.midmark.com

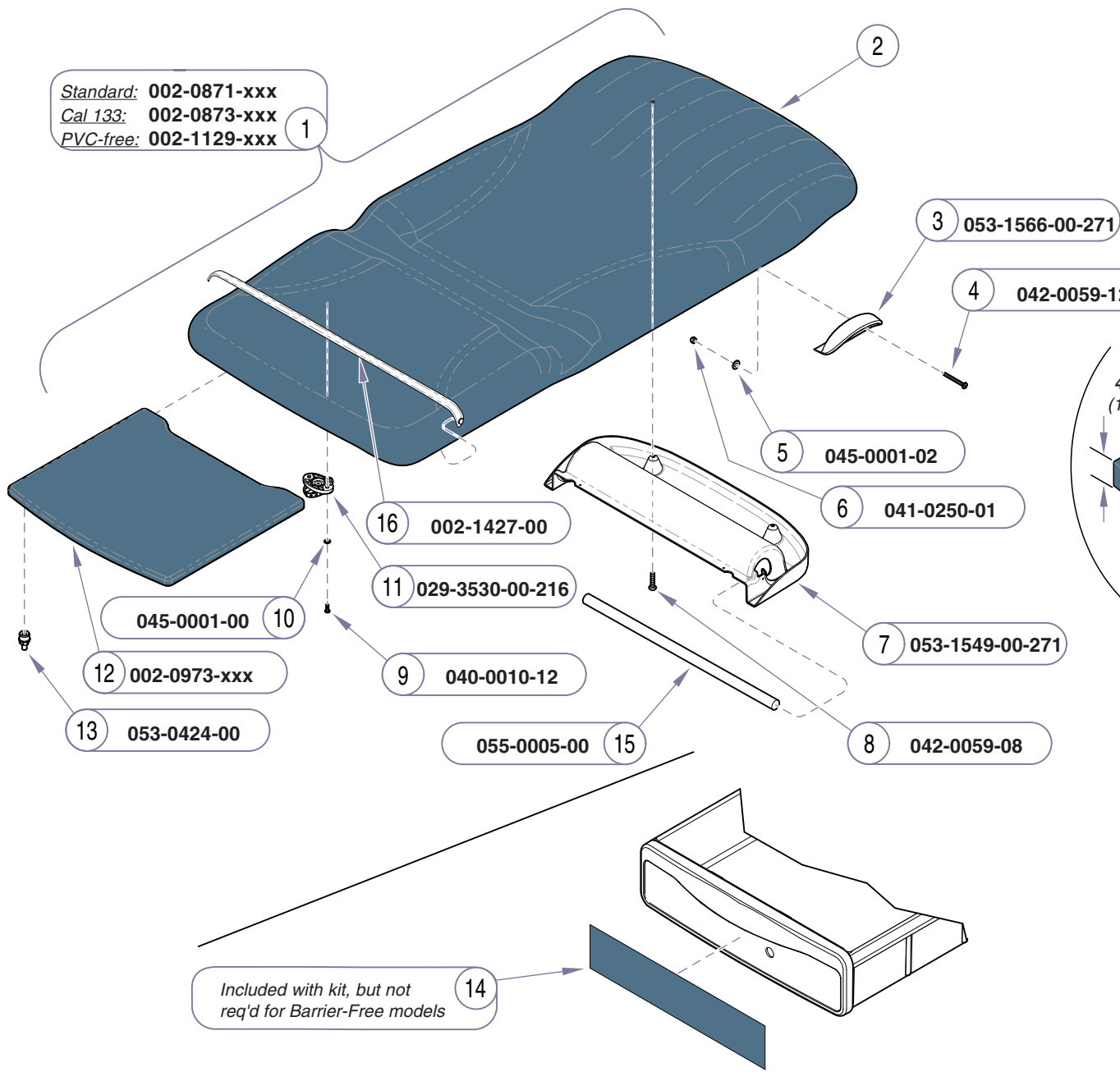

Item #17 is a special order option.

Note: The footrest shelf will not slide into the stowed position with this pad installed.

Standard: 002-0897-02-xxx
PVC-free: 002-1135-xxx

ATTENTION: Refer to *Color Selector* link for appropriate numbers to replace -xxx.

Item	Description	Qty.
1	Upholstery Set (includes items 2 thru 14)	1
2	• Seat/Back Upholstery	1
3	• Handle	2
4	• Bolt (1/4-20 x 1.578")	4
5	• Washer	4
6	• Nylock Nut	4
7	• Paper Roll Housing	1
8	• Screw (10-24 x 5/8")	4
9	• Screw	12
10	• Washer	12
11	• Locking Knob	6
12	• Footrest Pad - standard	1
13	• Footrest Glide	4
14	• Drawer Insert (for MET models only)	8
15	Dowel Rod	1
16	Tear Strap	1
17	Footrest Pad - special (4.25 in. thick) [includes four glides (item #13)]	1

Always Specify Model & Serial Number

Models: 222 (-015 thru -017) | 223 (-015 & -016)
Serial Numbers: All | All

Upholstery - Ritter
(Seamless)
©Midmark Corporation 2005 SF-1822 Rev. 1/11

1 **Standard:** 002-0747-xxx
Std. w/Heater: 002-0748-xxx
Cal 133: 002-0791-xxx
Cal 133 w/Heater: 002-0792-xxx

Refer To:
 Color Selector www.midmark.com

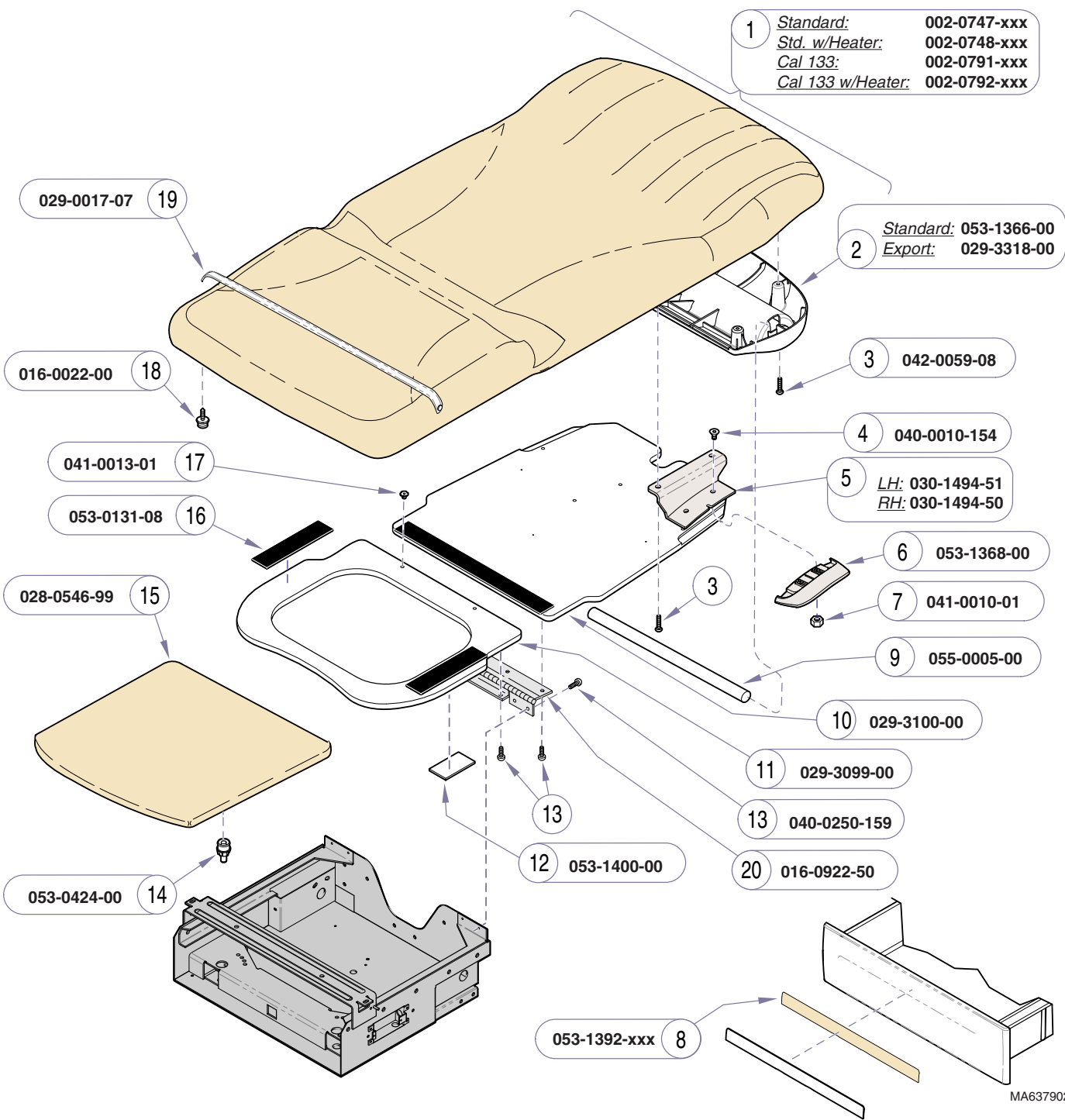

2 **Standard:** 053-1366-00
Export: 029-3318-00

3 042-0059-08

4 040-0010-154

5 **LH:** 030-1494-51
RH: 030-1494-50

6 053-1368-00

7 041-0010-01

9 055-0005-00

10 029-3100-00

11 029-3099-00

13 040-0250-159

20 016-0922-50

053-1392-xxx 8

MA637902i

ATTENTION: Refer to *Color Selector* link for appropriate numbers to replace -xxx.

Item	Description	Qty.
1	Upholstery Set (incl. items 2 thru 8)	1
2	• Paper Roll Holder - Export used on 622/623 (-003 & -004) only	1
3	• Screw (1/4 x 20 x .78")	8
4	• Screw (#10- 32 x .43")	4
5	• Grip Handle Bracket (LH shown)	1
6	• Grip Handle	2
7	• Nut (#10-32)	4
8	• Vinyl Drawer Insert	1
9	Paper Roll Dowel Rod	2
10	Back Mounting Frame (includes item 16)	1
11	Seat Mounting Frame (includes item 16)	1
12	Scuff Plate	2
13	Screw	4
14	Footrest Guide	4
15	Upholstered Footrest (specify color)	1
16	Velcro Hook (2" x 9")	2
17	Nutsert	11
18	Stud	2
19	Tear Straps Kit (includes two straps)	1
20	Hinge	1

Always Specify Model & Serial Number

Upholstery - Midmark
 (Premium)

Models: 622 (-001 thru -006) | 623 (-001 thru -006)
Serial Numbers: All | All

Refer To:

Color Selector www.midmark.com

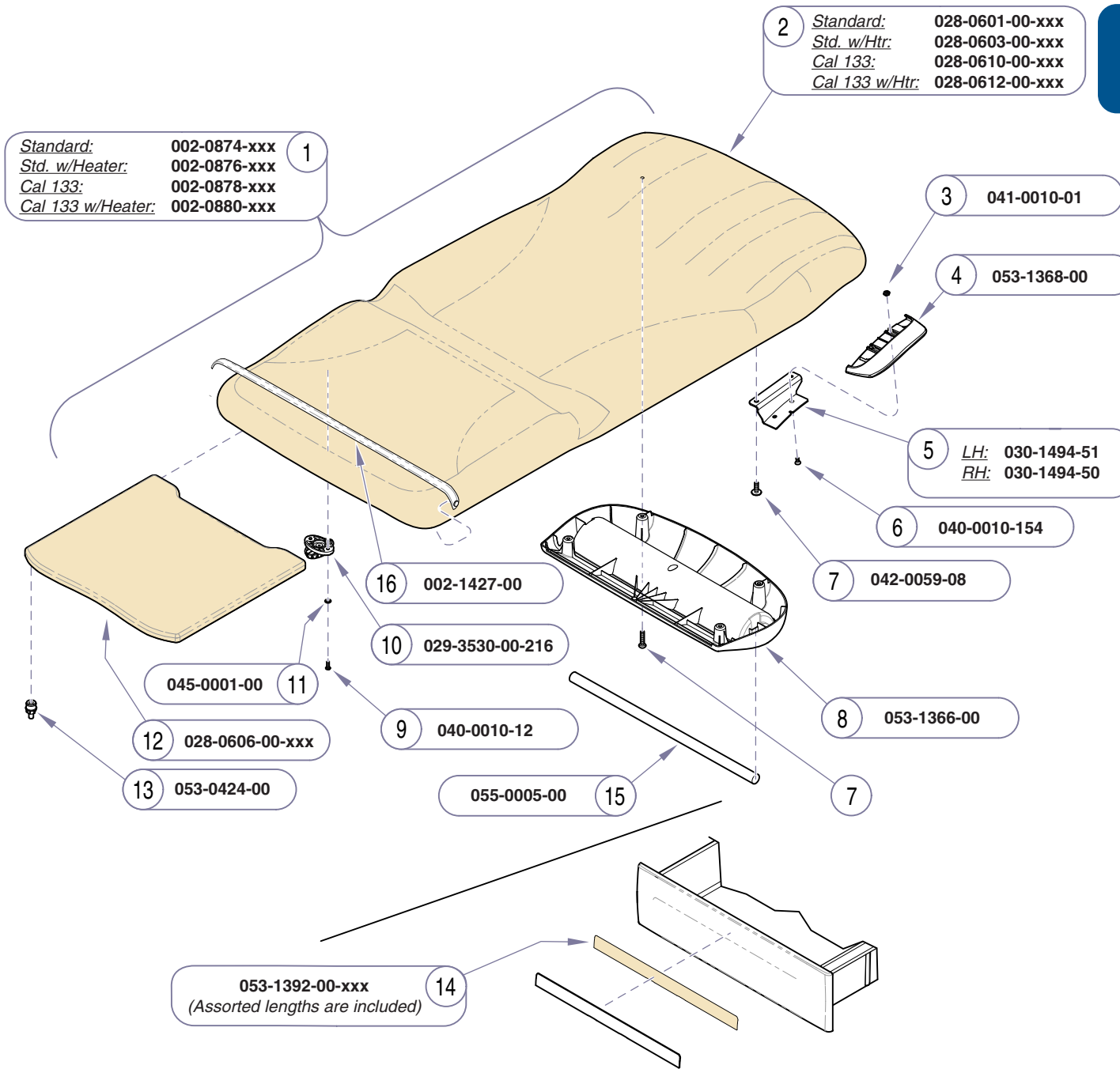

2 **Standard:** 028-0601-00-xxx
Std. w/Htr: 028-0603-00-xxx
Cal 133: 028-0610-00-xxx
Cal 133 w/Htr: 028-0612-00-xxx

1 **Standard:** 002-0874-xxx
Std. w/Heater: 002-0876-xxx
Cal 133: 002-0878-xxx
Cal 133 w/Heater: 002-0880-xxx

ATTENTION: Refer to *Color Selector* link for appropriate numbers to replace -xxx.

Item	Description	Qty.
1	Upholstery Set (includes items 2 thru 14)	1
2	• Seat/Back Upholstery	1
3	• Nut	4
4	• Handle	2
5	• Handle Bracket	2
6	• Screw	4
7	• Screw (10-24 x 5/8)	8
8	• Paper Roll Housing	1
9	• Screw	12
10	• Locking Knob	6
11	• Washer	12
12	• Footrest Pad (includes item 13- qty 4)	1
13	• • Footrest Glide	4
14	• Vinyl Drawer Insert	6
15	Dowel Rod	1
16	Tear Strap	1

Always Specify Model & Serial Number

MA705700i

Models: | **622 (-007 & -008)** | **623 (-007 thru -010)**
Serial Numbers: | All | All

Upholstery - Midmark
(Premium)

Refer To:
Color Selector www.midmark.com

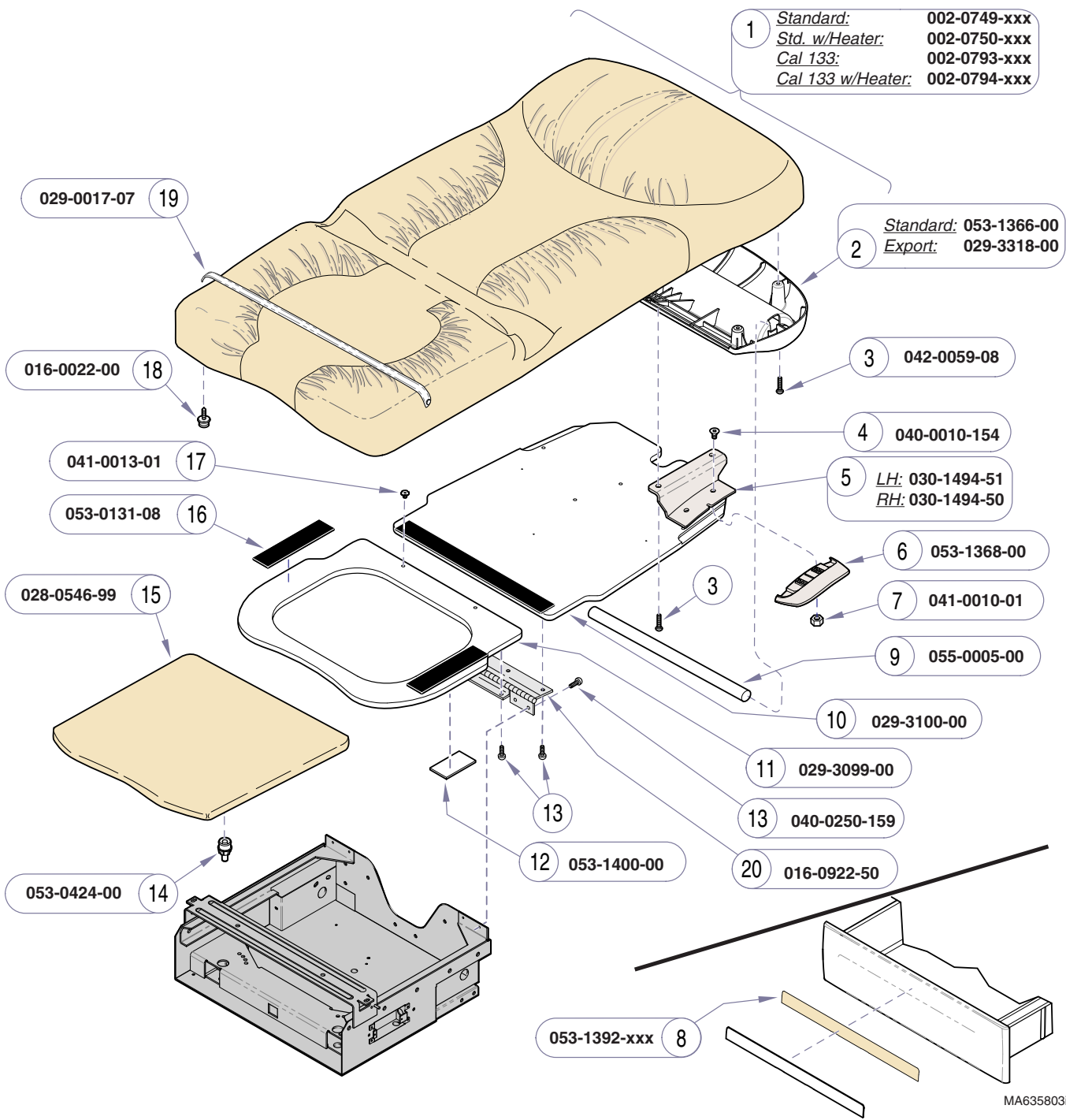

ATTENTION: Refer to *Color Selector* link for appropriate numbers to replace -xxx.

Item	Description	Qty.
1	Upholstery Set (incl. items 2 thru 7)	1
2	• Paper Roll Holder - <i>Export used on 622/623 (-003 & -004) only</i>	1
3	• Screw (1/4 x 20 x .78")	8
4	• Screw (#10- 32 x .43")	4
5	• Grip Handle Bracket (LH shown)	1
6	• Grip Handle	2
7	• Nut (#10-32)	4
8	• Vinyl Drawer Insert	1
9	Paper Roll Dowel Rod	2
10	Back Mounting Frame (includes item 16)	1
11	Seat Mounting Frame (includes item 16)	1
12	Scuff Plate	2
13	Screw	4
14	Footrest Guide	4
15	Upholstered Footrest (specify color)	1
16	Velcro Hook (2" x 9")	2
17	Nutsert	11
18	Stud	2
19	Tear Strap Kit (includes two straps)	1
20	Hinge	1

Always Specify Model & Serial Number

Upholstery - Midmark
(Ultra-Premium)

Models: | 622 (-001 thru -006) | 623 (-001 thru -006)
Serial Numbers: | All | All

Refer To:
Color Selector www.midmark.com

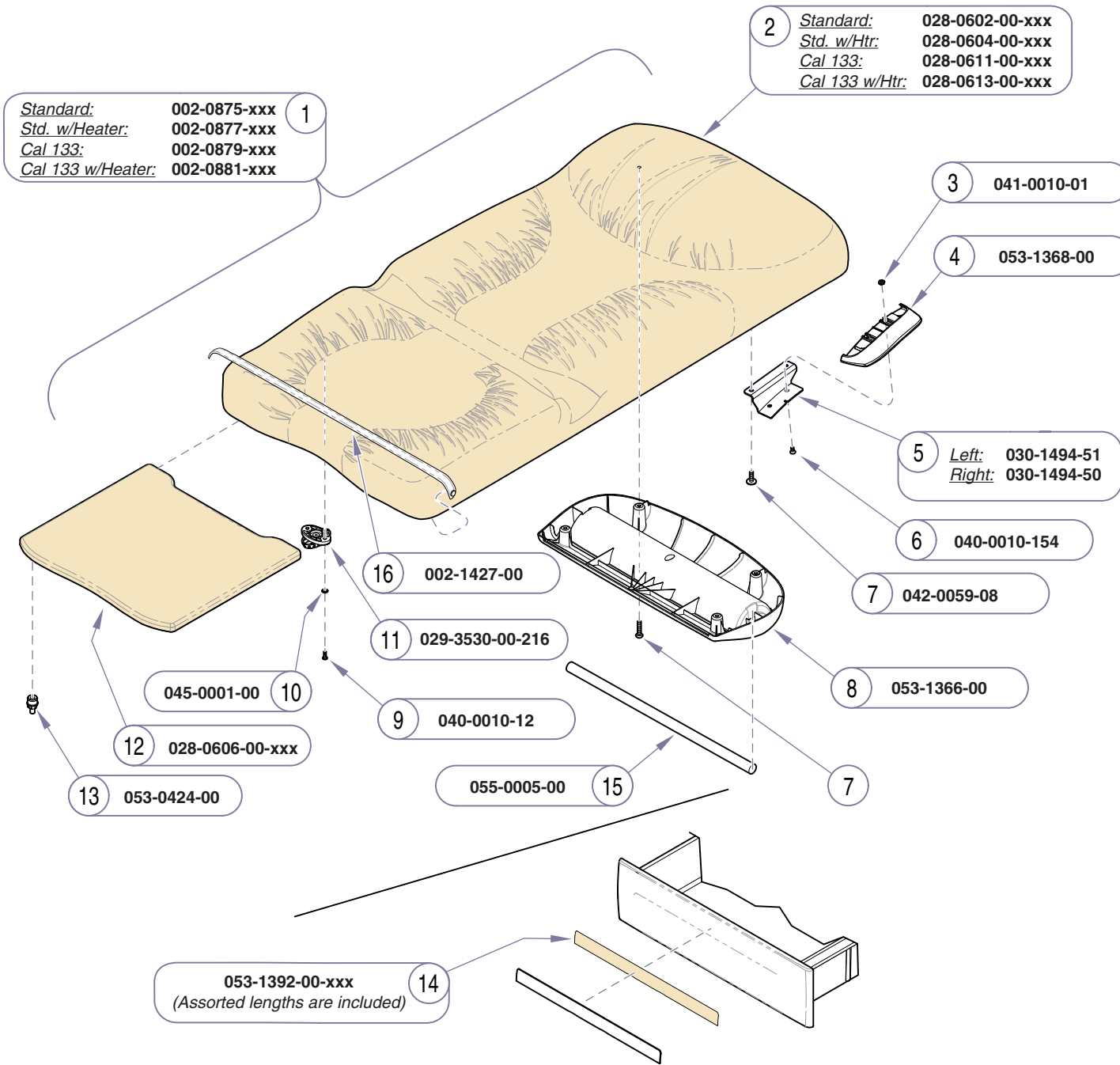

2 **Standard:** 028-0602-00-xxx
Std. w/Htr: 028-0604-00-xxx
Cal 133: 028-0611-00-xxx
Cal 133 w/Htr: 028-0613-00-xxx

1 **Standard:** 002-0875-xxx
Std. w/Heater: 002-0877-xxx
Cal 133: 002-0879-xxx
Cal 133 w/Heater: 002-0881-xxx

3 041-0010-01

4 053-1368-00

5 **Left:** 030-1494-51
Right: 030-1494-50

6 040-0010-154

7 042-0059-08

8 053-1366-00

16 002-1427-00

11 029-3530-00-216

9 040-0010-12

045-0001-00 10

12 028-0606-00-xxx

13 053-0424-00

055-0005-00 15

053-1392-00-xxx 14
(Assorted lengths are included)

MA705800i

ATTENTION: Refer to *Color Selector* link for appropriate numbers to replace -xxx.

Item	Description	Qty.
1	Upholstery Set (includes items 2 thru 14)....	1
2	• Seat/Back Upholstery	1
3	• Nut	4
4	• Handle	2
5	• Handle Bracket	2
6	• Screw	4
7	• Screw (10-24 x 5/8)	8
8	• Paper Roll Housing	1
9	• Screw	12
10	• Washer	12
11	• Locking Knob	6
12	• Footrest Pad (includes item 13 - qty 4)	1
13	• • Footrest Glide	4
14	• Vinyl Drawer Insert	6
15	Dowel Rod	1
16	Tear Strap	1

Always Specify Model & Serial Number

Models: 622 (-007 & -008) | 623 (-007 thru -010)
Serial Numbers: All | All

Upholstery - Midmark
(Ultra-Premium)

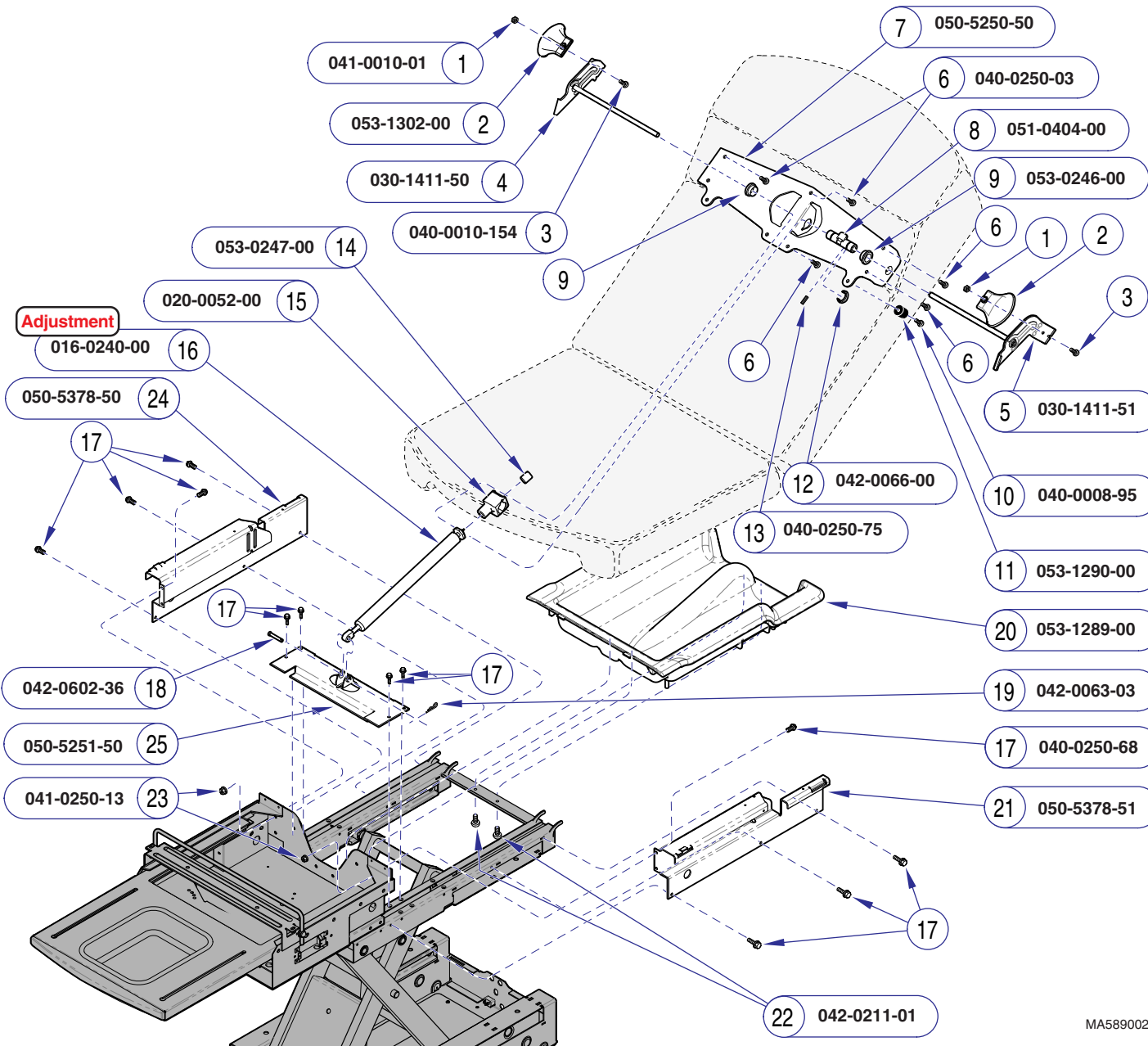

Item	Description	Qty.
1	Nut	2
2	Actuator Release Handle	2
3	Screw (10-32 x 7/16")	1
4	R.H. Back Release Weldment	1
5	L.H. Back Release Weldment	1
6	Screw (1/4-20 x 7/8")	4
7	Release Support Yoke Back	1
8	Cam	1
9	Back Pivot Bearing	2
10	Wood Screw	2
11	Stem Bumper	2
12	Crescent Ring	2
13	Set Screw	2
14	Plunger	1
15	Actuator Cap	1
16	Gas Cylinder	1
17	Screw (1/4-20 x Type F)	16
18	Clevis Pin	1
19	Rue Ring	1
20	Top Cover	1
21	L.H. Side Support	1
22	Screw (5mm x 20mm)	7
23	Lock Nut	4
24	R.H. Side Support	1
25	Manual Back Release	1

Always Specify Model & Serial Number

MA5890021

Models: Serial Numbers:	222 (-001 thru -010)	622 (-001 & -002)	
	RG1000 thru RG1894	RH1000 thru RH2131	SJ1000 thru SJ1008
	RJ1000 thru RJ1419	RK1000 thru RK3589	SK1000 thru SK1029
	RL1000 thru RL1068	RM1000 thru RM1028	

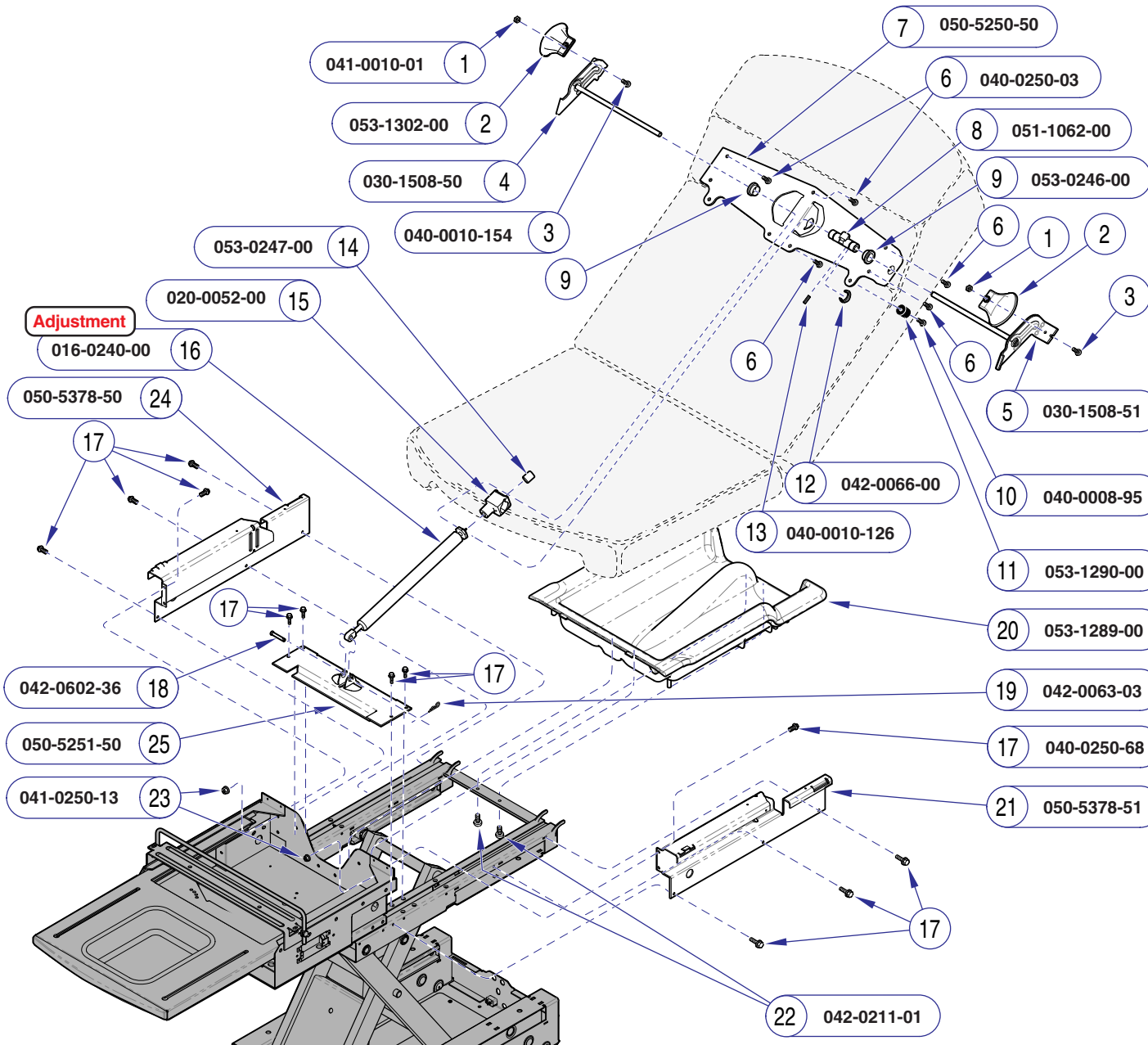

Item	Description	Qty.
1	Nut	2
2	Actuator Release Handle	2
3	Screw (10-32 x 7/16")	1
4	R.H. Back Release Weldment	1
5	L.H. Back Release Weldment	1
6	Screw (1/4-20 x 7/8")	4
7	Release Support Yoke Back	1
8	Cam	1
9	Back Pivot Bearing	2
10	Wood Screw	2
11	Stem Bumper	2
12	Crescent Ring	2
13	Set Screw	2
14	Plunger	1
15	Actuator Cap	1
16	Gas Cylinder	1
17	Screw (1/4-20 x Type F)	16
18	Clevis Pin	1
19	Rue Ring	1
20	Top Cover	1
21	L.H. Side Support	1
22	Screw (5mm x 20mm)	3
23	Lock Nut	4
24	R.H. Side Support	1
25	Manual Back Release	1

Always Specify Model & Serial Number

MA5890021

Models:	222 (-001 thru -014)	622 (-001 thru -006)
	Serial Numbers: RG1895 thru present RJ1420 thru present RL1069 thru present RH2132 thru present	RK3590 thru present RM1029 thru present V2200 thru V216996

Refer To: **Page**
 Gas Cylinder **Adjustment** B-18
 Backrest Handles E-3

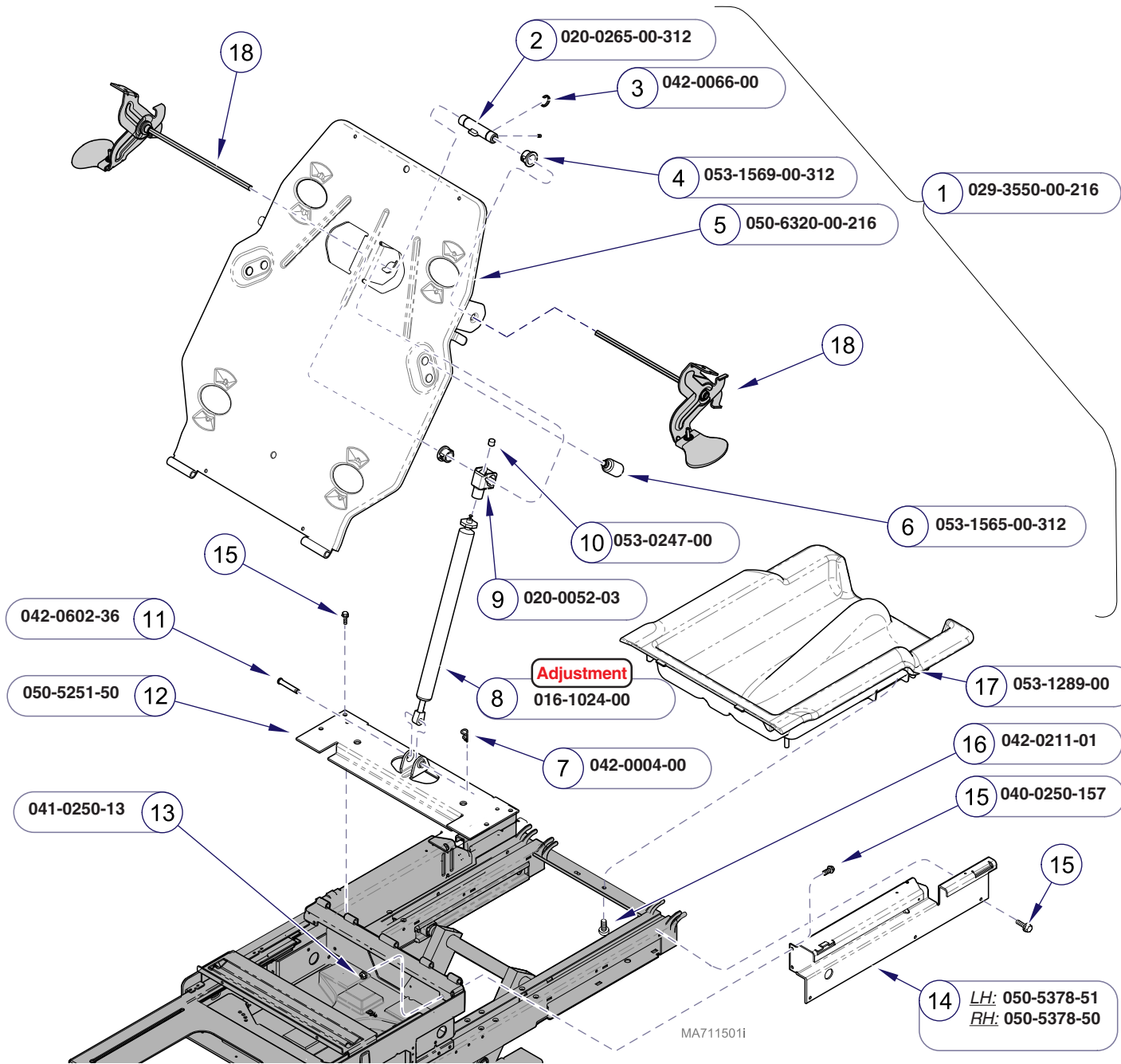

Item	Description	Qty.
1	Manual Back Assembly (incl. items 2 thru 12)	1
2	• Cam	1
3	• Crescent Ring	2
4	• Back Pivot Bearing	2
5	• Back Mounting Frame	1
6	• Back Rest Bumper	2
7	• Hitch Pin	1
8	• Gas Spring	1
9	• Actuator Cap	1
10	• Plunger	1
11	• Clevis Pin	1
12	• Release Support Yoke	1
13	Lock Nut	4
14	Side Support (LH shown)	2
15	Screw (1/4-20 x Type F)	16
16	Screw (5mm x 20mm)	2
17	Top Cover	1
18	Refer to: "Backrest Handles"	Ref

Always Specify Model & Serial Number

E-10.2

Manual Back Components

Models: 222 (-015 thru -017) | 622 (-007 & -008)
Serial Numbers: V216996 thru present | V216996 thru present

Refer To: **Page**
 Back Actuator E-12*
 * multiple pages due to model / serial # break

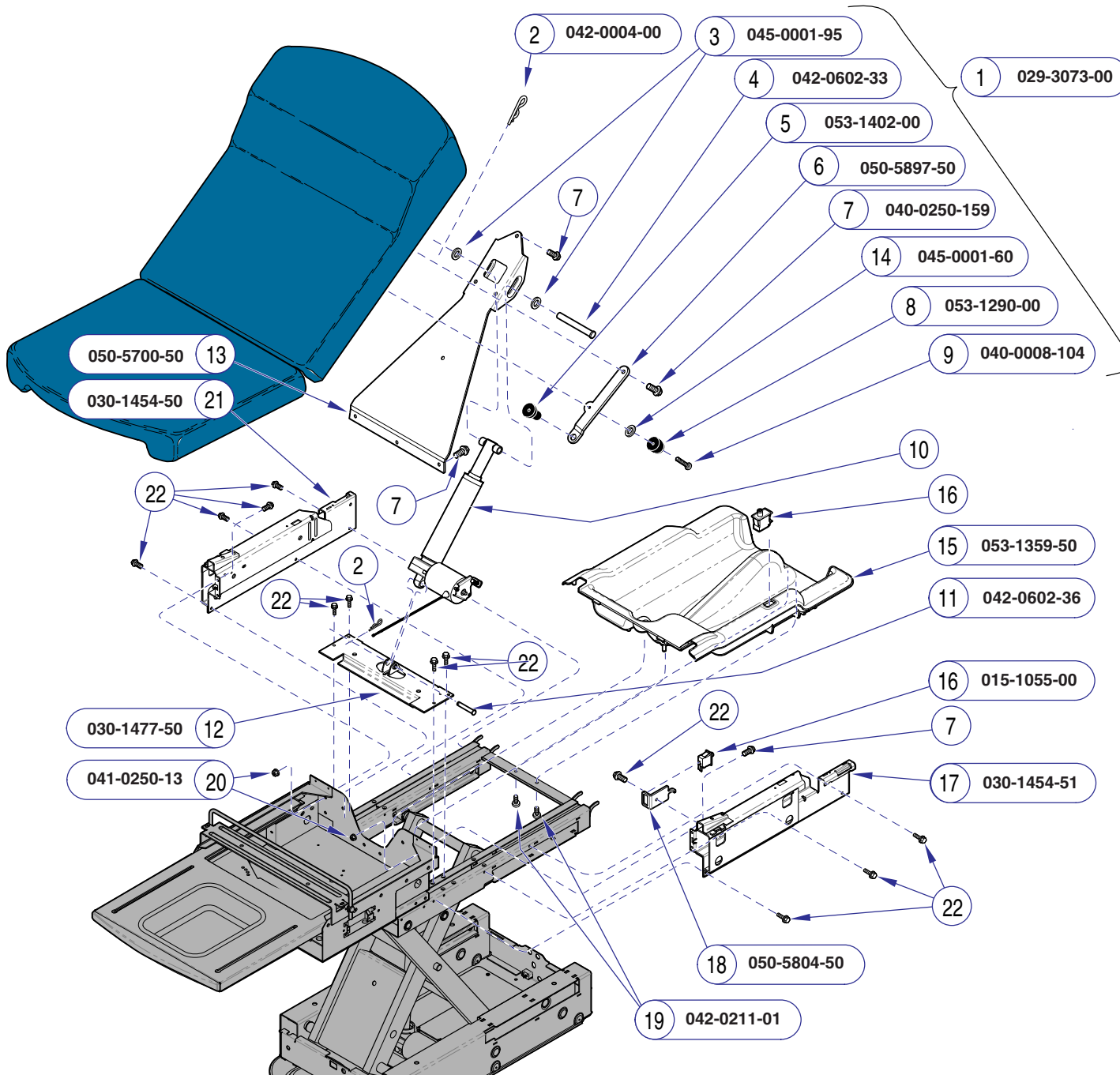

Item	Description	Qty.
1	Power Back Assembly <i>(includes items 2 thru 14)</i>	1
2	• Hitch Pin Clip	2
3	• Washer	2
4	• Clevis Pin	1
5	• Stem Bumper	1
6	• Limit Bumper Bracket <i>(leftside only)</i>	1
7	• Screw <i>(1/4-20 x .87")</i>	6
8	• Recess Bumper	3
9	• Screw <i>(#8 x 1")</i>	3
10	• Refer to: "Back Actuator"	Ref
11	• Clevis Pin	1
12	• Back Actuator Support	1
13	• Power Back Pivot Mount	1
14	• Spacer Washer <i>(right side only)</i>	1
15	Top Cover	1
16	Limit Switch	2
17	L.H. Side Support	1
18	Switch Bracket	1
19	Screw <i>(M5 x 20mm)</i>	3
20	Flange Nut <i>(1/4-20)</i>	4
21	R.H. Side Support	1
22	Screw <i>(1/4-20 x .5")</i>	19

Always Specify Model & Serial Number

MA637000i

Models: 223 (-001 thru -014) | 623 (-001 thru -006)
Serial Numbers: All | All

**Power Back
 Components**

Refer To: **Page**
 Back Actuator E-12*
 * multiple pages due to model / serial # break

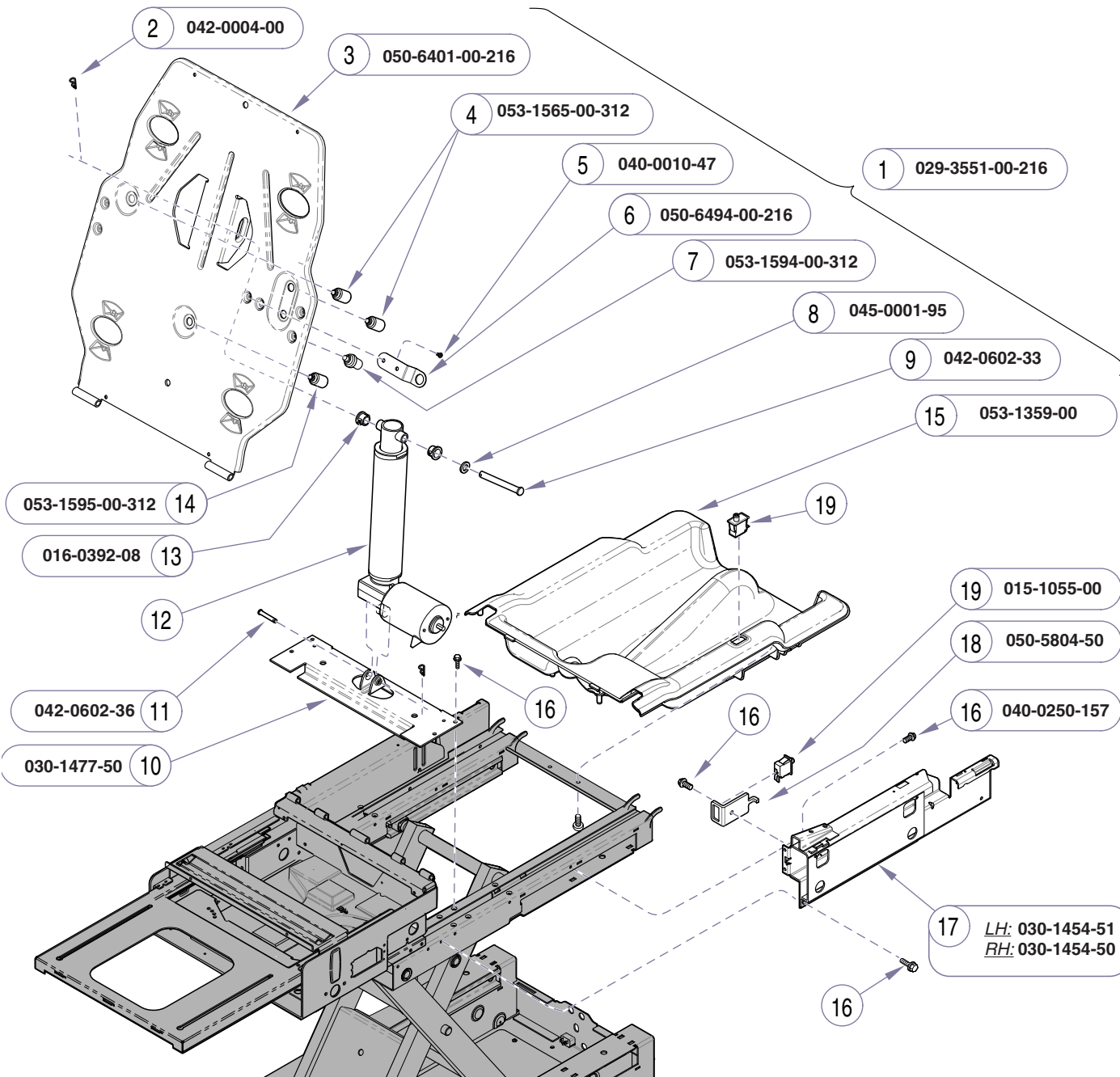

Item	Description	Qty.
1	Power Back Assembly (includes items 2 thru 13)	1
2	• Hitch Pin Clip	1
3	• Back Mounting Frame	1
4	• Back Rest Bumper	2
5	• Screw (#10-24 x 3/8')	2
6	• Limit Bumper Bracket (leftside only)	1
7	• Limit Switch Bumper	1
8	• Washer (1/2')	2
9	• Clevis Pin	1
10	• Back Actuator Support	1
11	• Clevis Pin	1
12	• Refer to: "Back Actuator"	Ref
13	• DU Bearing	2
14	• Actuator Stop Bumper	1
15	Top Cover	1
16	Screw (1/4"-20 x .5")	19
17	Side Support (LH shown)	2
18	Limit Switch Bracket	1
19	Limit Switch	2

Always Specify Model & Serial Number

MA712900i

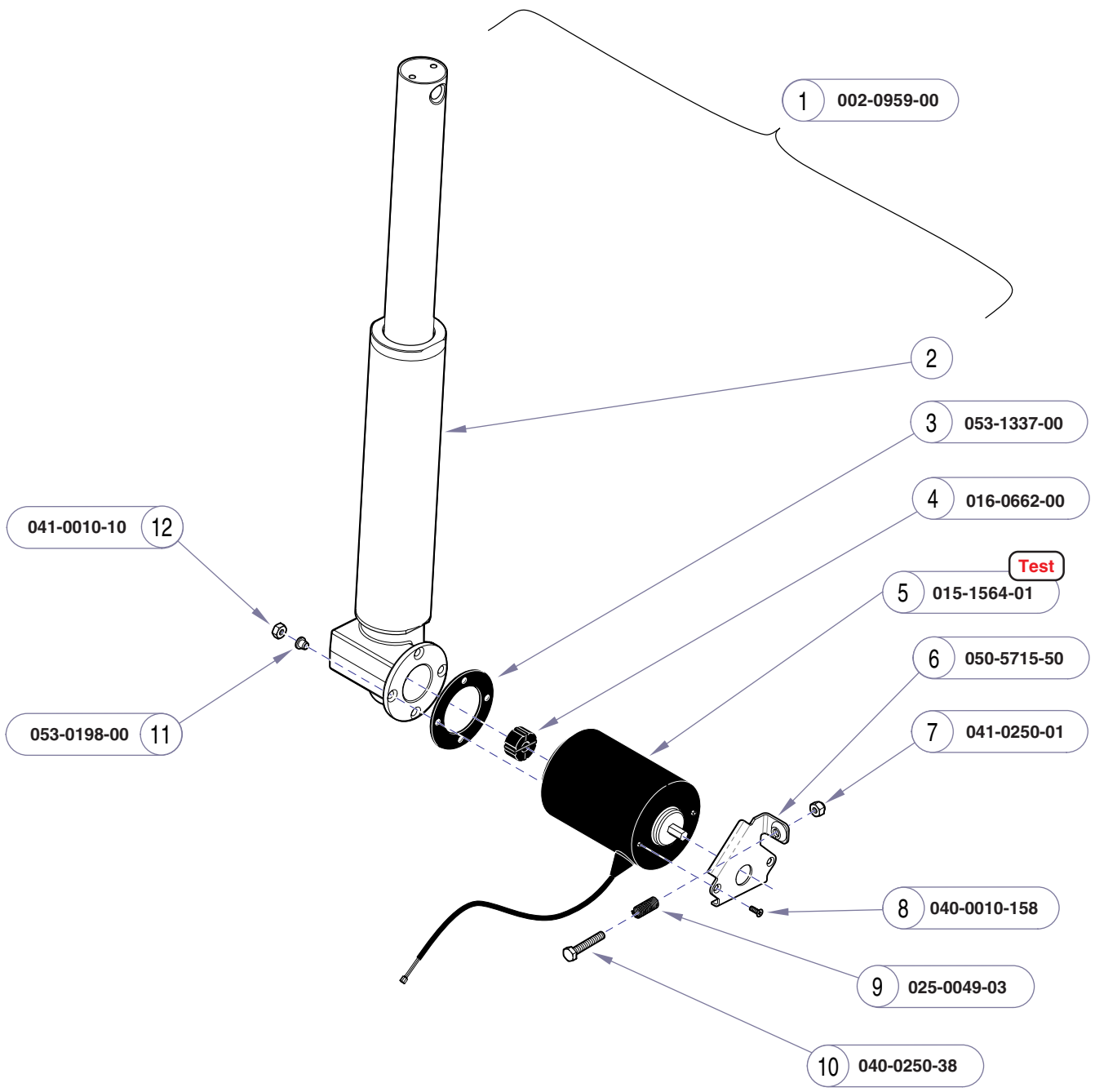

Item	Description	Qty.
1	Back Actuator Assembly Kit (includes items 1 thru 12)	1
2	• Actuator (not available separately)	Ref.
3	• Motor Insulator	1
4	• Motor Coupler	1
5	• Actuator Motor	1
6	• Motor Bracket	1
7	• Nut (1/4"-20)	1
8	• Screw (#10 x 32 x .25")	2
9	• Compression Spring	1
10	• Screw (1/4" -20 x .5")	1
11	• Shoulder Washer	2
12	• Nut (#10-32).....	2

Always Specify Model & Serial Number

MA624201i

Models: | **223 (all)** | **623 (all)**
 Serial Numbers: | All | All

Back Actuator

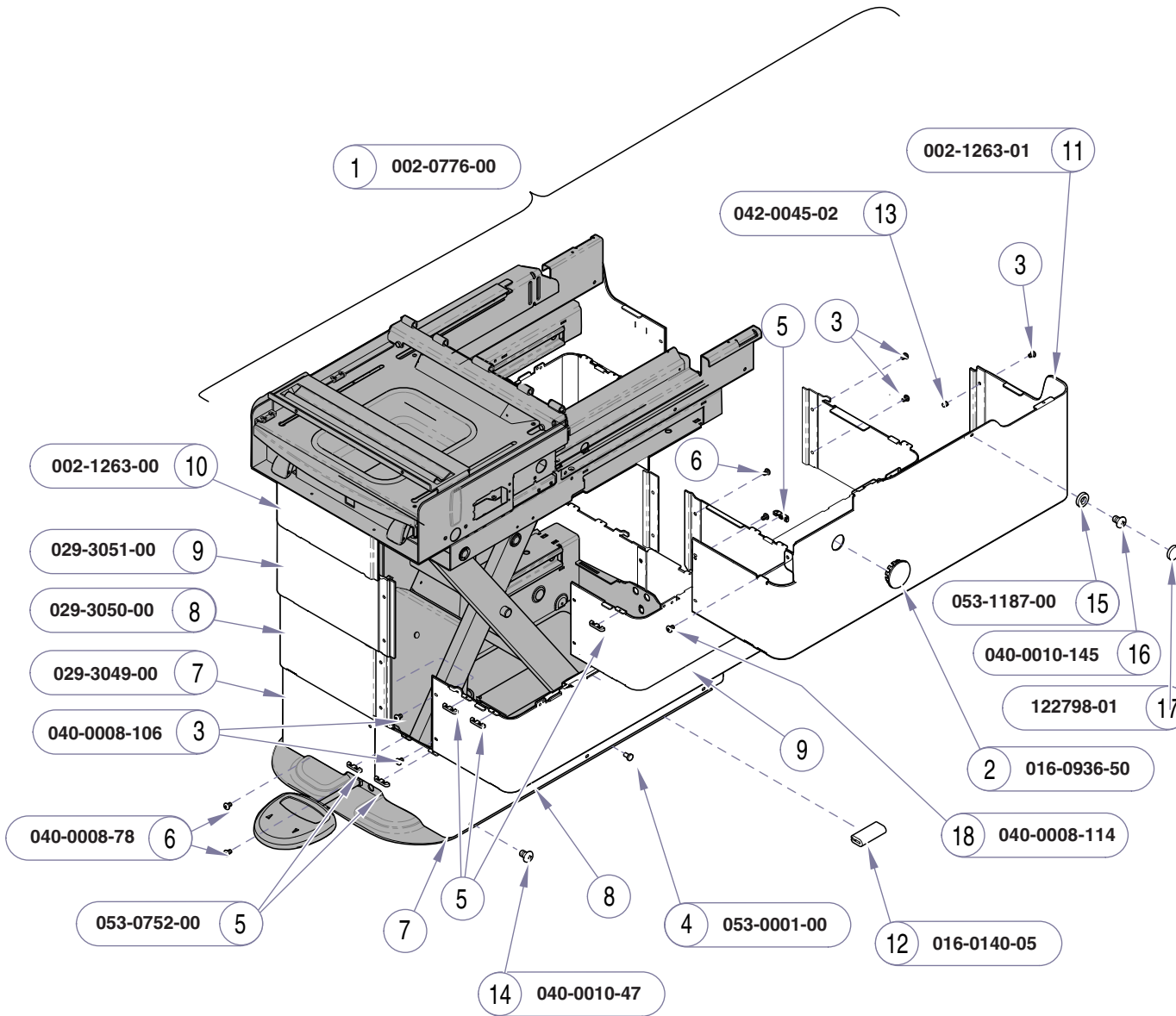

Item	Description	Qty.
1	Table Shroud Assembly Set	1
	<i>(includes items 2 thru 14)</i>	
2	• Hole Plug	2
3	• Screw (#8-32 x .25")	12
4	• Stem Bumper	14
5	• Snap-on Guide	32
6	• Screw (#8 -32 x .25")	4
7	• Inner Shroud Assembly	2
	<i>(includes items 4, 5, & 13)</i>	
8	• Mid Inner Shroud Assembly	2
	<i>(includes items 4, 5, 12, & 13)</i>	
9	• Mid Outer Shroud Assembly	2
	<i>(includes items 4, 5, & 13)</i>	
10	• R.H. Outer Shroud Assembly	1
	<i>(includes items 5, 13, & 18)</i>	
11	• L.H. Outer Shroud Assembly	1
	<i>(includes items 5, 13, & 18)</i>	
12	• Trim Lock	4
13	• Nutsert	18
14	• Screw (10-24 x 3/8")	6
15	Screw Cover Base	2
16	Screw (10-24 x 3/8")	2
17	Screw Cover	2
18	Screw (#8-32 x 3/8")	2

Always Specify Model & Serial Number

MA715700i

Models:	222 (all)		223 (all)	
	RG1531 thru present	RH1821 thru RH1830	SC-prefixes (all)	SG-prefixes (all)
Serial Numbers:	RJ1313 thru present	RH1833 thru present	SD-prefixes (all)	SH-prefixes (all)
	RK2335 thru present	RL1061 thru present	SE-prefixes (all)	V2200 thru V761999
	RM1016 thru present	V2200 thru V761999	SF-prefixes (all)	

Table Shrouds
(Ritter models)

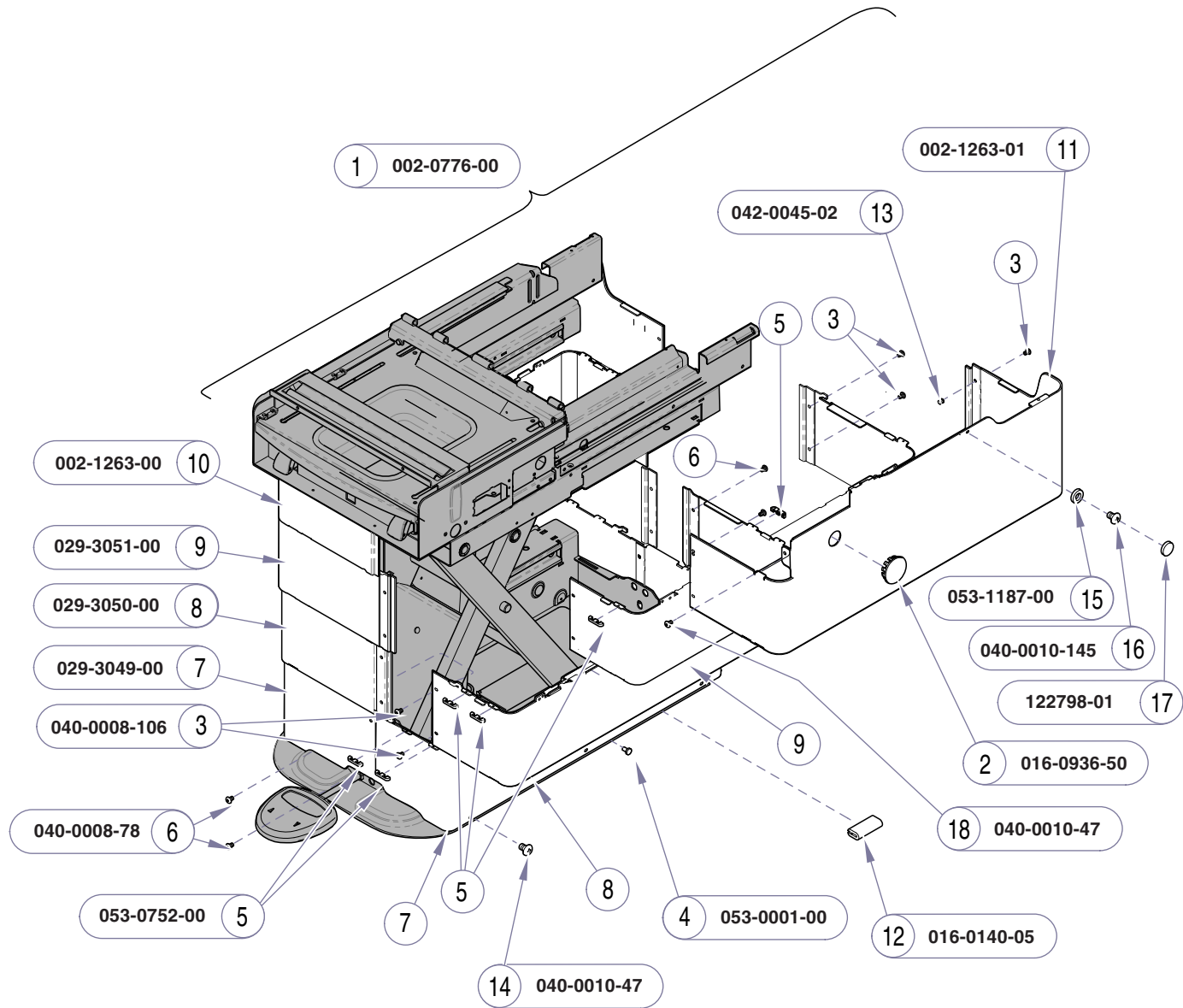

Item	Description	Qty.
1	Table Shroud Assembly Set	1
	<i>(includes items 2 thru 14)</i>	
2	• Hole Plug	2
3	• Screw (#8-32 x .25")	12
4	• Stem Bumper	14
5	• Snap-on Guide	32
6	• Screw (#8-32 x .25")	4
7	• Inner Shroud Assembly	2
	<i>(includes items 4, 5, & 13)</i>	
8	• Mid Inner Shroud Assembly	2
	<i>(includes items 4, 5, 12, & 13)</i>	
9	• Mid Outer Shroud Assembly	2
	<i>(includes items 4, 5, & 13)</i>	
10	• R.H. Outer Shroud Assembly	1
	<i>(includes items 5, 13, & 18)</i>	
11	• L.H. Outer Shroud Assembly	1
	<i>(includes items 5, 13, & 18)</i>	
12	• Trim Lock	4
13	• Nutsert	18
14	• Screw (10-24 x 3/8")	6
15	Screw Cover Base	2
16	Screw (10-24 x 3/8")	2
17	Screw Cover	2
18	Screw (#10-24 x 3/8")	2

Always Specify Model & Serial Number

MA715700i

Table Shrouds
(Ritter models)

Models: 222 (all) | 223 (all)
Serial Numbers: V762688 thru V7077078 | V762688 thru V7077078

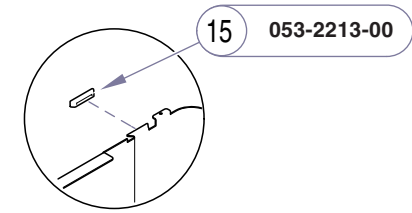
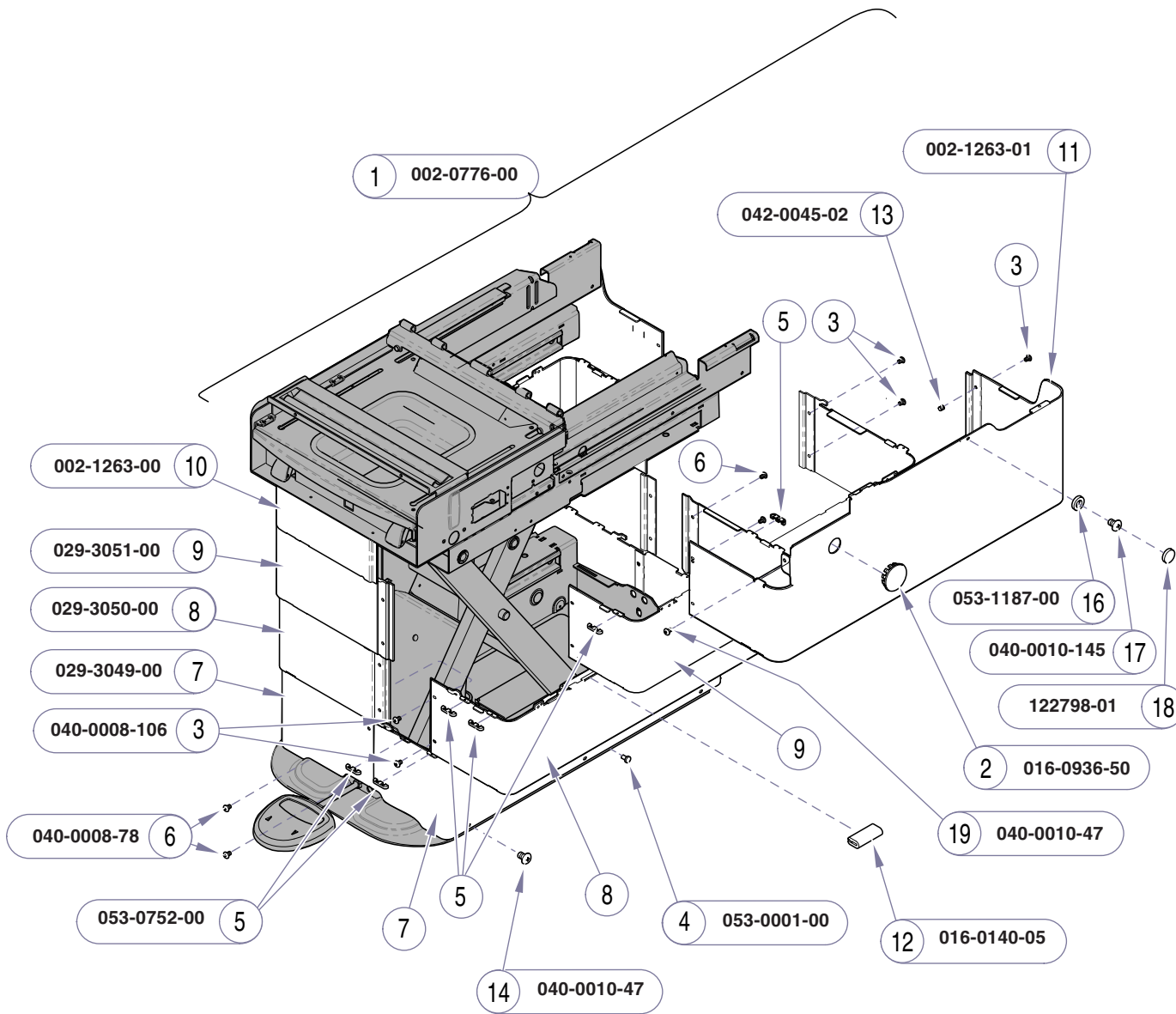

Item	Description	Qty.
1	Table Shroud Assembly Set	1
	<i>(includes items 2 thru 15)</i>	
2	• Hole Plug	2
3	• Screw (#8-32 x .25")	12
4	• Stem Bumper	14
5	• Snap-on Guide	32
6	• Screw (#8-32 x .25")	4
7	• Inner Shroud Assembly	2
	<i>(includes items 4, 5, & 13)</i>	
8	• Mid Inner Shroud Assembly	2
	<i>(includes items 4, 5, 12, 13, & 15)</i>	
9	• Mid Outer Shroud Assembly	2
	<i>(includes items 4, 5, 13, & 15)</i>	
10	• R.H. Outer Shroud Assembly	1
	<i>(includes items 5, 13, & 18)</i>	
11	• L.H. Outer Shroud Assembly	1
	<i>(includes items 5, 13, & 18)</i>	
12	• Trim Lock	4
13	• Nutsert	18
14	• Screw (10-24 x 3/8")	6
15	• Shroud Isolator	4
16	Screw Cover Base	2
17	Screw (10-24 x 3/8")	2
18	Screw Cover	2
19	Screw (#10-24 x 3/8")	2

Always Specify Model & Serial Number

MA715701i

Models: **222 (all)** | **223 (all)**
 Serial Numbers: V1077079 thru V1089389 | V1077079 thru V1089389

Table Shrouds
(Ritter models)

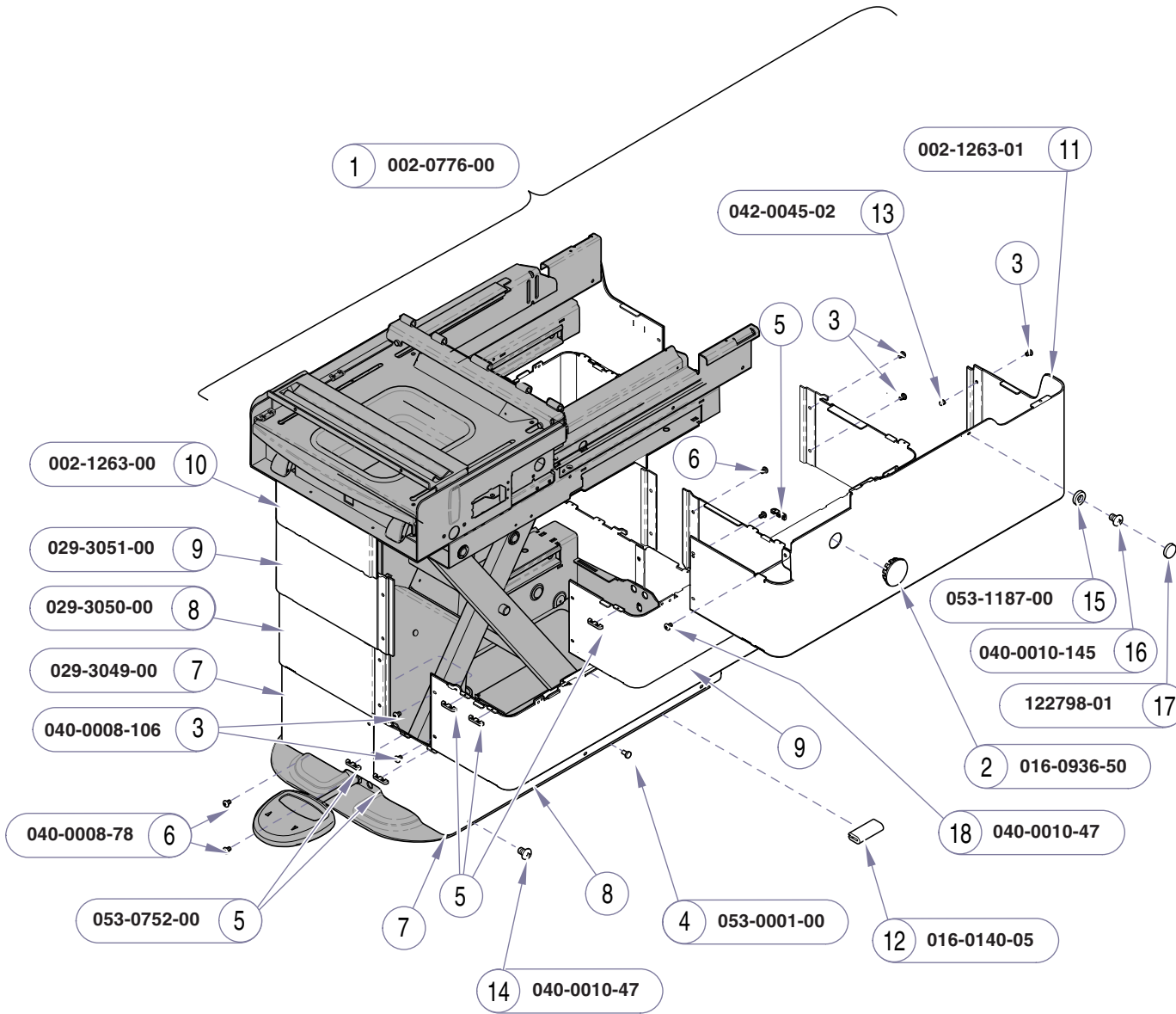

MA715702

Item	Description	Qty.
1	Table Shroud Assembly Set 1 <i>(includes items 2 thru 14)</i>	1
2	• Hole Plug 2	2
3	• Screw (#8-32 x .25") 12	12
4	• Stem Bumper 14	14
5	• Snap-on Guide 32	32
6	• Screw (#8 -32 x .25") 4	4
7	• Inner Shroud Assembly 2 <i>(includes items 4, 5, & 13)</i>	2
8	• Mid Inner Shroud Assembly 2 <i>(includes items 4, 5, 12, & 13)</i>	2
9	• Mid Outer Shroud Assembly 2 <i>(includes items 4, 5, & 13)</i>	2
10	• R.H. Outer Shroud Assembly 1 <i>(includes items 5, 13, & 18)</i>	1
11	• L.H. Outer Shroud Assembly 1 <i>(includes items 5, 13, & 18)</i>	1
12	• Trim Lock 4	4
13	• Nutsert 18	18
14	• Screw (10-24 x 3/8") 6	6
15	Screw Cover Base 2	2
16	Screw (10-24 x 3/8") 2	2
17	Screw Cover 2	2
18	Screw (#10-24 x 3/8") 2	2

Always Specify Model & Serial Number

E-13.4

Table Shrouds (Ritter models)

Models: 222 (all) | 223 (all)
Serial Numbers: V1089390 thru V1099004 | V1089390 thru V1099004

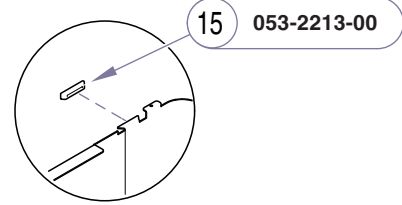
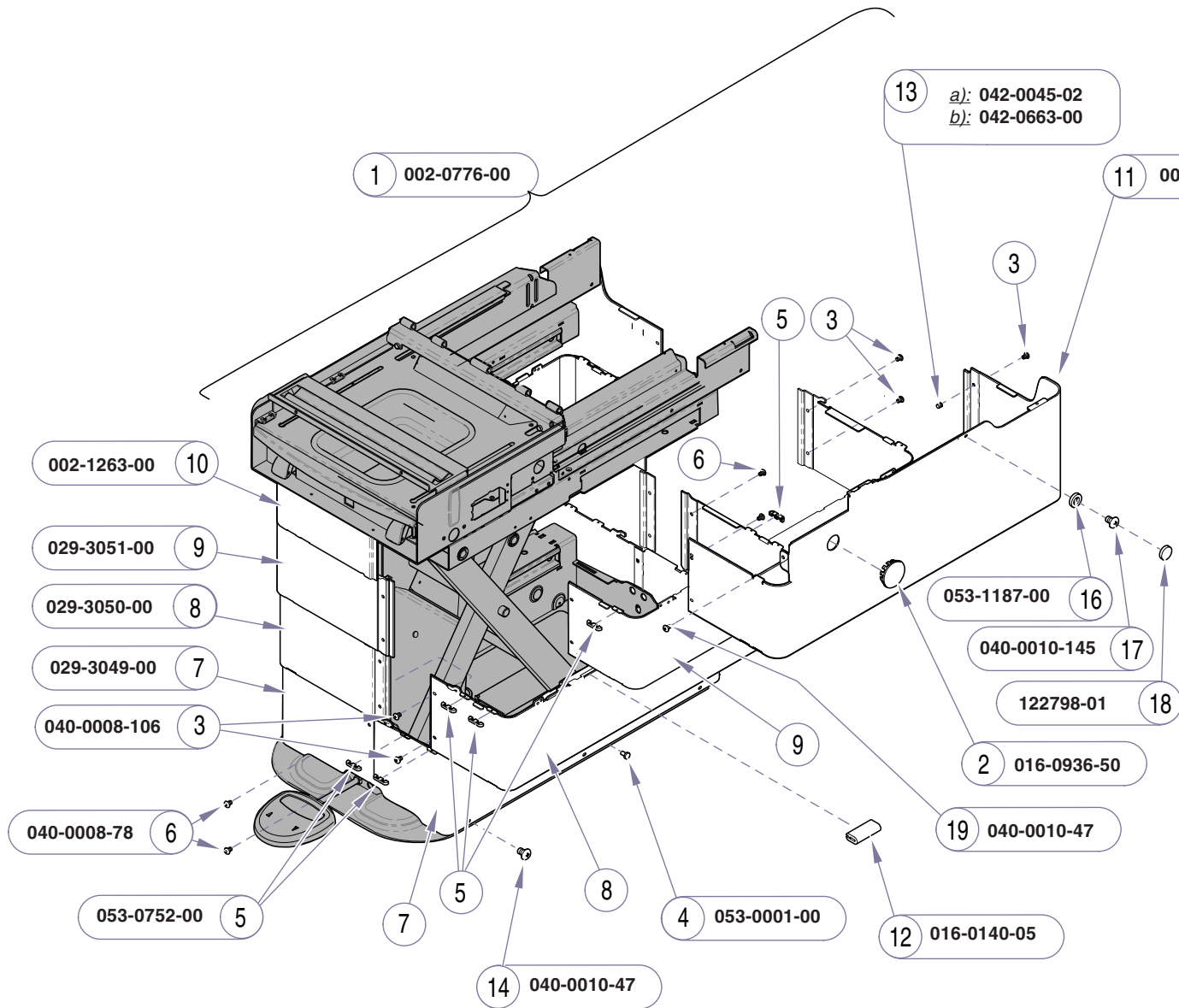

Item	Description	Qty.
1	Table Shroud Assembly Set	1
	<i>(includes items 2 thru 15)</i>	
2	• Hole Plug	2
3	• Screw (#8-32 x .25")	12
4	• Stem Bumper	14
5	• Snap-on Guide	32
6	• Screw (#8 -32 x .25")	4
7	• Inner Shroud Assembly	2
	<i>(includes items 4, 5, & 13)</i>	
8	• Mid Inner Shroud Assembly	2
	<i>(includes items 4, 5, 12, 13, & 15)</i>	
9	• Mid Outer Shroud Assembly	2
	<i>(includes items 4, 5, 13, & 15)</i>	
10	• R.H. Outer Shroud Assembly	1
	<i>(includes items 5, 13, & 18)</i>	
11	• L.H. Outer Shroud Assembly	1
	<i>(includes items 5, 13, & 18)</i>	
12	• Trim Lock	4
13	• a) Nutsert (Round)	18
	• b) Nutsert (Hex)	18
14	• Screw (10-24 x 3/8")	6
15	• Shroud Isolator	4
16	Screw Cover Base	2
17	Screw (10-24 x 3/8")	2
18	Screw Cover	2
19	Screw (#10-24 x 3/8")	2

Always Specify Model & Serial Number

MA715703i

Models:	222 (all)	223 (all)
Serial Numbers:	V1099005 thru present	V1099005 thru present

Table Shrouds
(Ritter models)

1 002-0908-00

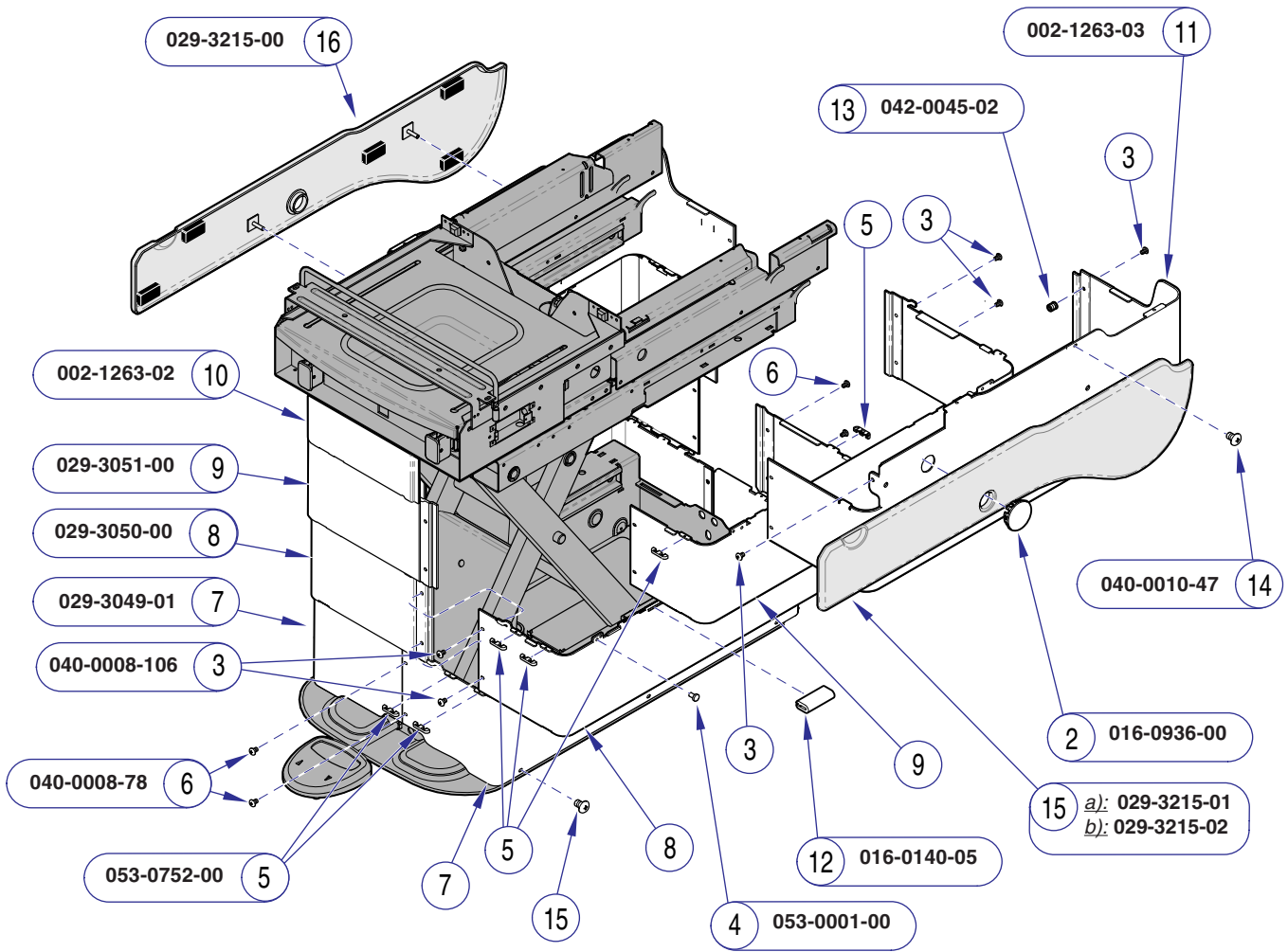

Item	Description	Qty.
1	Table Shroud Assembly Set	1
	(includes items 2 thru 13)	
2	• Hole Plug	2
3	• Screw (#8 -32 x .25")	12
4	• Stem Bumper	32
5	• Snap-on Guide	36
6	• Screw (#8 -32 x .25")	4
7	• Inner Shroud Assembly	2
	(includes items 13)	
8	• Mid Inner Shroud Assembly	2
	(includes items 4, 5, 12 & 13)	
9	• Mid Outer Shroud Assembly	2
	(includes items, 4, 5, 13, & 14)	
10	• R.H. Outer Shroud Assembly	1
	(includes items, 3, & 13)	
11	• L.H. Outer Shroud Assembly	1
	(includes items, 3, & 13)	
12	• Trim Lock	4
13	• Nutsert	18
14	Screw (10-24 x 1/2")	10
15	LH Cladding Assembly:	
	a) w/ receptacle cutout	1
	b) w/o receptacle cutout	1
16	R.H. Cladding Assembly	1

Always Specify Model & Serial Number

MA637804i

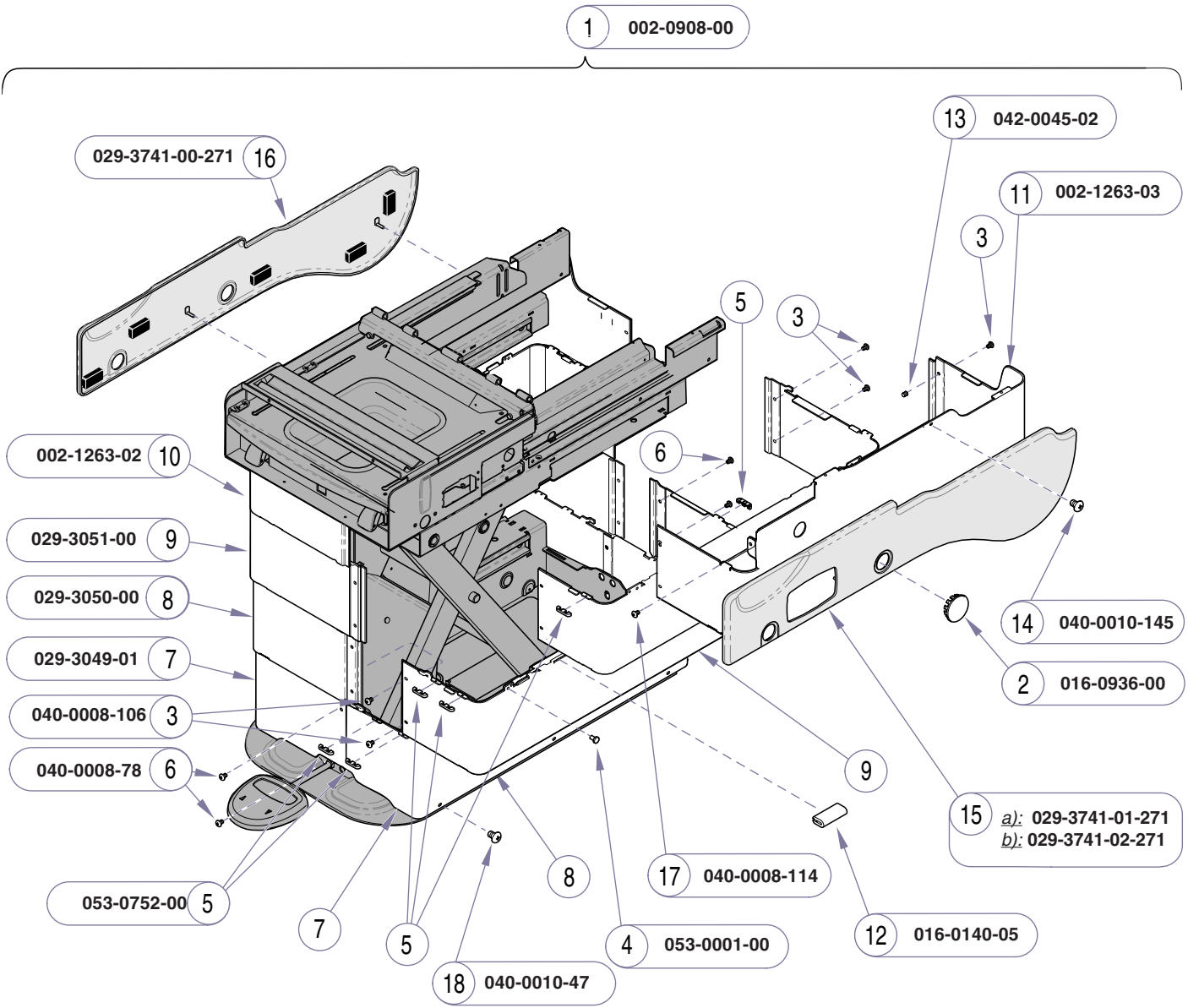

Item	Description	Qty.
1	Table Shroud Assembly Set	1
	(includes items 2 thru 14)	
2	• Hole Plug	4
3	• Screw (#8 -32 x .25")	12
4	• Stem Bumper	14
5	• Snap-on Guide	32
6	• Screw (#8 -32 x .25")	4
7	• Inner Shroud Assembly	2
	(includes items 4, 5, & 13)	
8	• Mid Inner Shroud Assembly	2
	(includes items 4, 5, 12 & 13)	
9	• Mid Outer Shroud Assembly	2
	(includes items 4, 5, & 13)	
10	• R.H. Outer Shroud Assembly	1
	(includes items 3, 13, 14, & 17)	
11	• L.H. Outer Shroud Assembly	1
	(includes items 3, 13, 14, & 17)	
12	• Trim Lock	4
13	• Nutsert	18
14	• Screw (10-24 x 1/2")	2
15	LH Cladding Assembly:	
	a) w/ receptacle cutout	1
	b) w/o receptacle cutout	1
16	R.H. Cladding Assembly	1
17	Screw (#8-32 x 3/8")	2
18	Screw	6

Always Specify Model & Serial Number

MA715800i

Models:	622 (-007 & -008)	623 (-007 thru -010)
Serial Numbers:	V216996 thru V761999	V216996 thru V761999

Table Shrouds
(Midmark models)

1 002-0908-00

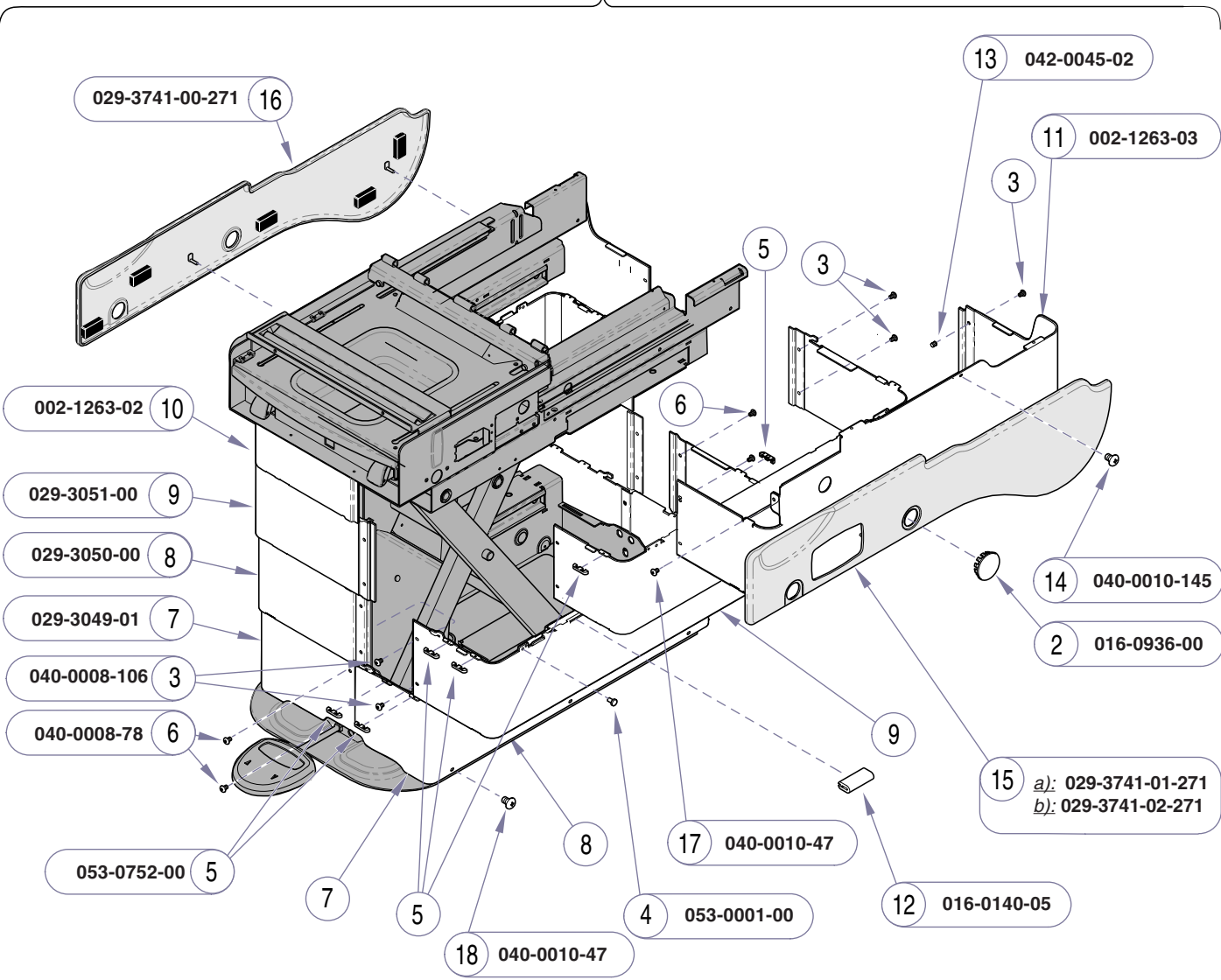

Item	Description	Qty.
1	Table Shroud Assembly Set	1
	(includes items 2 thru 14)	
2	• Hole Plug	4
3	• Screw (#8 -32 x .25")	12
4	• Stem Bumper	14
5	• Snap-on Guide	32
6	• Screw (#8 -32 x .25")	4
7	• Inner Shroud Assembly	2
	(includes items 4, 5, & 13)	
8	• Mid Inner Shroud Assembly	2
	(includes items 4, 5, 12 & 13)	
9	• Mid Outer Shroud Assembly	2
	(includes items 4, 5, & 13)	
10	• R.H. Outer Shroud Assembly	1
	(includes items 3, 13, 14, & 17)	
11	• L.H. Outer Shroud Assembly	1
	(includes items 3, 13, 14, & 17)	
12	• Trim Lock	4
13	• Nutsert	18
14	• Screw (10-24 x 1/2")	2
15	LH Cladding Assembly:	
	a) w/ receptacle cutout	1
	b) w/o receptacle cutout	1
16	R.H. Cladding Assembly	1
17	Screw (#10-24 x 3/8")	2
18	Screw	6

Always Specify Model & Serial Number

MA715800i

E-14.2 **Table Shrouds**
(Midmark models)

Models: 622 (-007 & -008) | 623 (-007 thru -010)
Serial Numbers: V762688 thru V1077078 | V762688 thru V1077078

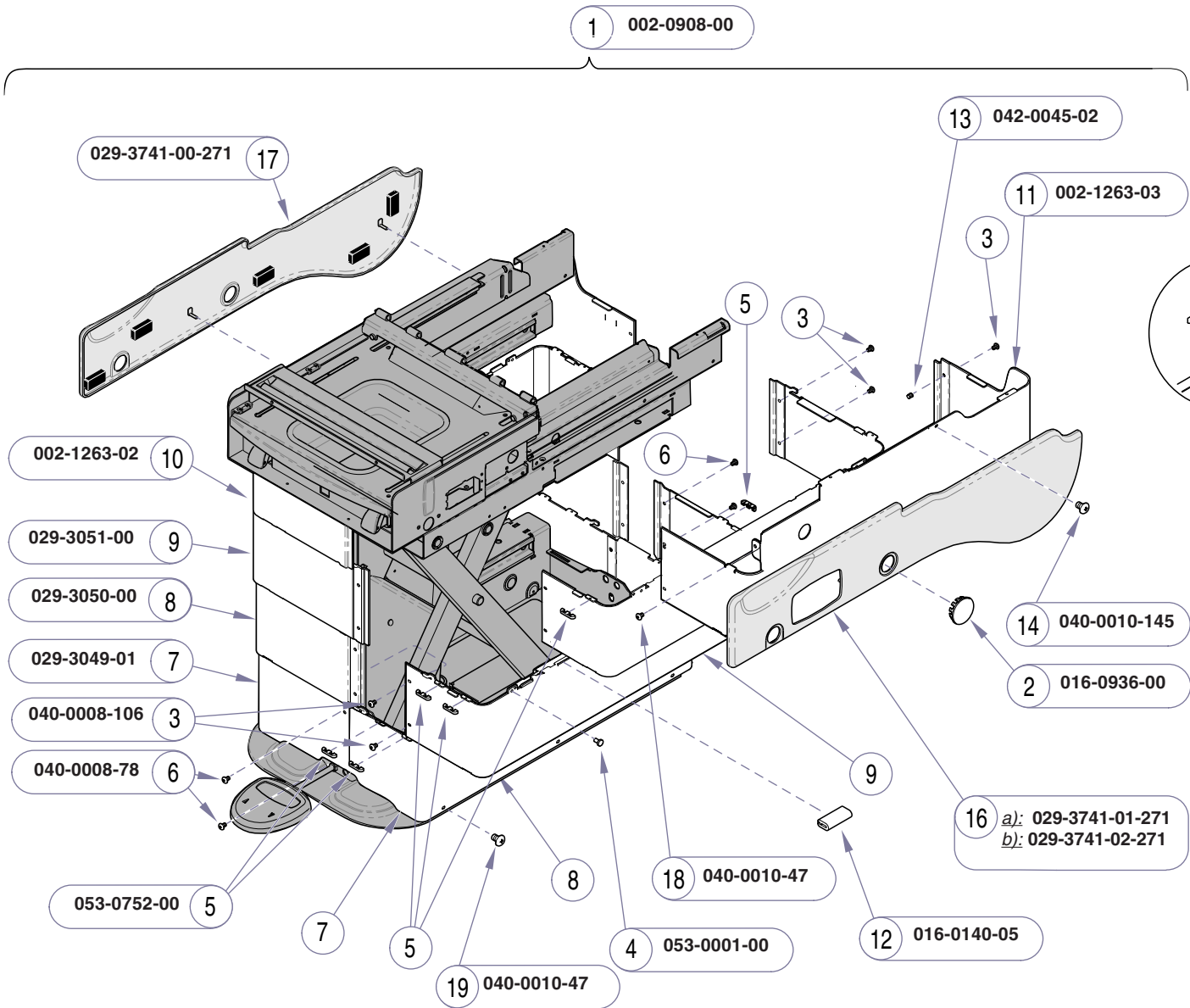

Item	Description	Qty.
1	Table Shroud Assembly Set	1
	(includes items 2 thru 15)	
2	• Hole Plug	4
3	• Screw (#8 -32 x .25")	12
4	• Stem Bumper	14
5	• Snap-on Guide	32
6	• Screw (#8 -32 x .25")	4
7	• Inner Shroud Assembly	2
	(includes items 4, 5, & 13)	
8	• Mid Inner Shroud Assembly	2
	(includes items 4, 5, 12, 13, & 15)	
9	• Mid Outer Shroud Assembly	2
	(includes items 4, 5, 13, & 15)	
10	• R.H. Outer Shroud Assembly	1
	(includes items 3, 13, 14, & 18)	
11	• L.H. Outer Shroud Assembly	1
	(includes items 3, 13, 14, & 18)	
12	• Trim Lock	4
13	• Nutsert	18
14	• Screw (10-24 x 1/2")	2
15	• Shroud Isolator	4
16	LH Cladding Assembly:	
	a) w/ receptacle cutout	1
	b) w/o receptacle cutout	1
17	R.H. Cladding Assembly	1
18	Screw (#10-24 x 3/8")	2
19	Screw	6

Always Specify Model & Serial Number

MA715801i

Models: 622 (-007 & -008) 623 (-007 thru -010)
Serial Numbers: V1077079 thru V1089389 V1077079 thru V1089389

Table Shrouds
 (Midmark models)

E-14.3

1 002-0908-00

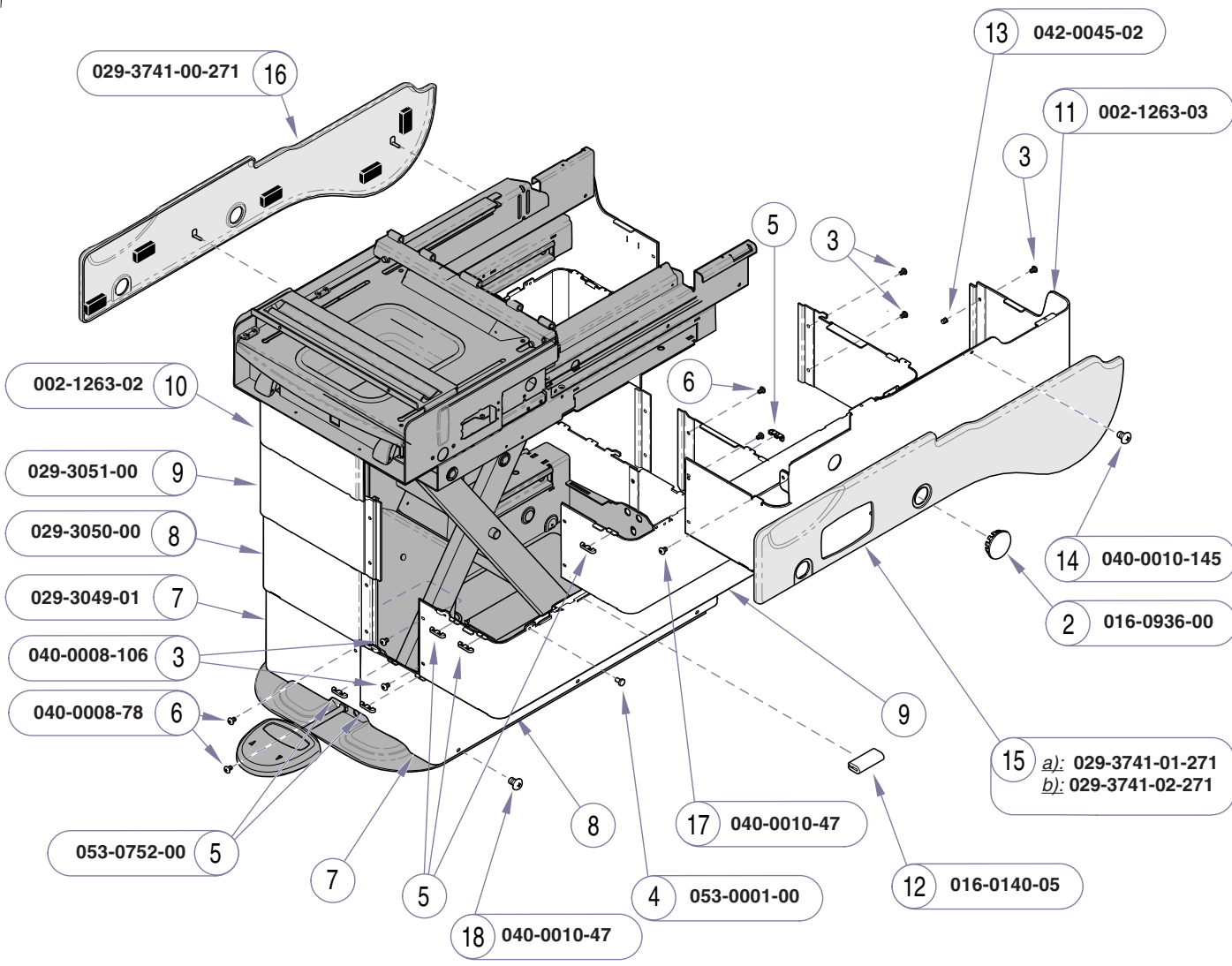

Item	Description	Qty.
1	Table Shroud Assembly Set	1
	(includes items 2 thru 14)	
2	• Hole Plug	4
3	• Screw (#8 -32 x .25")	12
4	• Stem Bumper	14
5	• Snap-on Guide	32
6	• Screw (#8 -32 x .25")	4
7	• Inner Shroud Assembly	2
	(includes items 4, 5, & 13)	
8	• Mid Inner Shroud Assembly	2
	(includes items 4, 5, 12 & 13)	
9	• Mid Outer Shroud Assembly	2
	(includes items 4, 5, & 13)	
10	• R.H. Outer Shroud Assembly	1
	(includes items 3, 13, 14, & 17)	
11	• L.H. Outer Shroud Assembly	1
	(includes items 3, 13, 14, & 17)	
12	• Trim Lock	4
13	• Nutsert	18
14	• Screw (10-24 x 1/2")	2
15	LH Cladding Assembly:	
	a) w/ receptacle cutout	1
	b) w/o receptacle cutout	1
16	R.H. Cladding Assembly	1
17	Screw (#10-24 x 3/8")	2
18	Screw	6

Always Specify Model & Serial Number

MA715802I

E-14.4 **Table Shrouds**
(Midmark models)

Models: 622 (-007 & -008) | 623 (-007 thru -010)
Serial Numbers: V1089390 thru V1099004 | V1089390 thru V1099004

1 002-0908-00

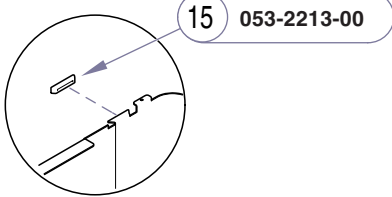
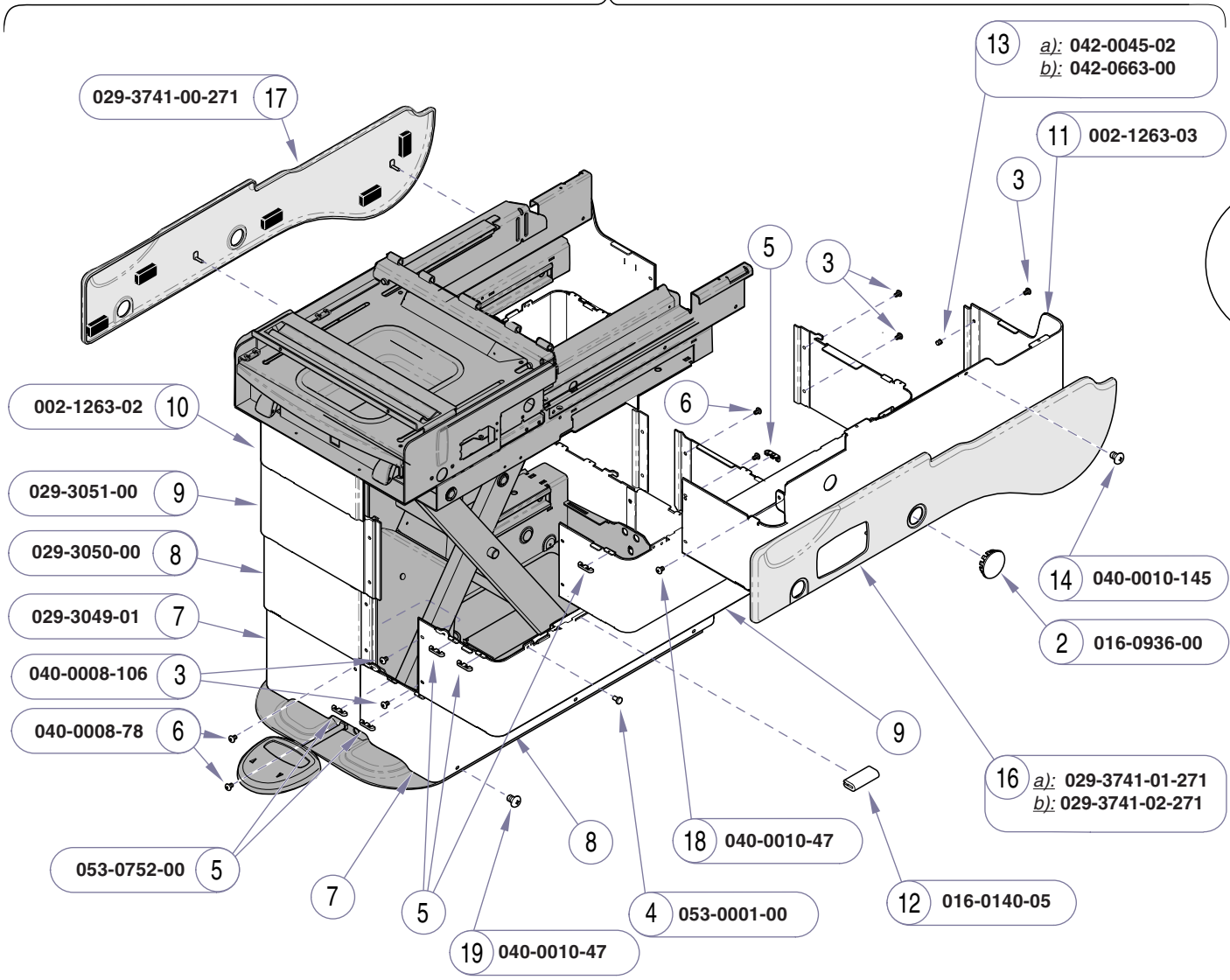

Item	Description	Qty.
1	Table Shroud Assembly Set	1
	(includes items 2 thru 15)	
2	• Hole Plug	4
3	• Screw (#8 -32 x .25")	12
4	• Stem Bumper	14
5	• Snap-on Guide	32
6	• Screw (#8 -32 x .25")	4
7	• Inner Shroud Assembly	2
	(includes items 4, 5, & 13)	
8	• Mid Inner Shroud Assembly	2
	(includes items 4, 5, 12, 13, & 15)	
9	• Mid Outer Shroud Assembly	2
	(includes items 4, 5, 13, & 15)	
10	• R.H. Outer Shroud Assembly	1
	(includes items 3, 13, 14, & 18)	
11	• L.H. Outer Shroud Assembly	1
	(includes items 3, 13, 14, & 18)	
12	• Trim Lock	4
13	• a) Nutsert (Round)	18
	• b) Nutsert (Hex)	18
14	• Screw (10-24 x 1/2")	2
15	• Shroud Isolator	4
16	LH Cladding Assembly:	
	a) w/ receptacle cutout	1
	b) w/o receptacle cutout	1
17	R.H. Cladding Assembly	1
18	Screw (#10-24 x 3/8")	2
19	Screw	6

Always Specify Model & Serial Number

MA715803i

Models: 622 (-007 & -008) | 623 (-007 thru -010)
Serial Numbers: V1099005 thru Present | V1099005 thru Present

Table Shrouds
 (Midmark models)

Ritter Upperwrap & Footrest Shelf

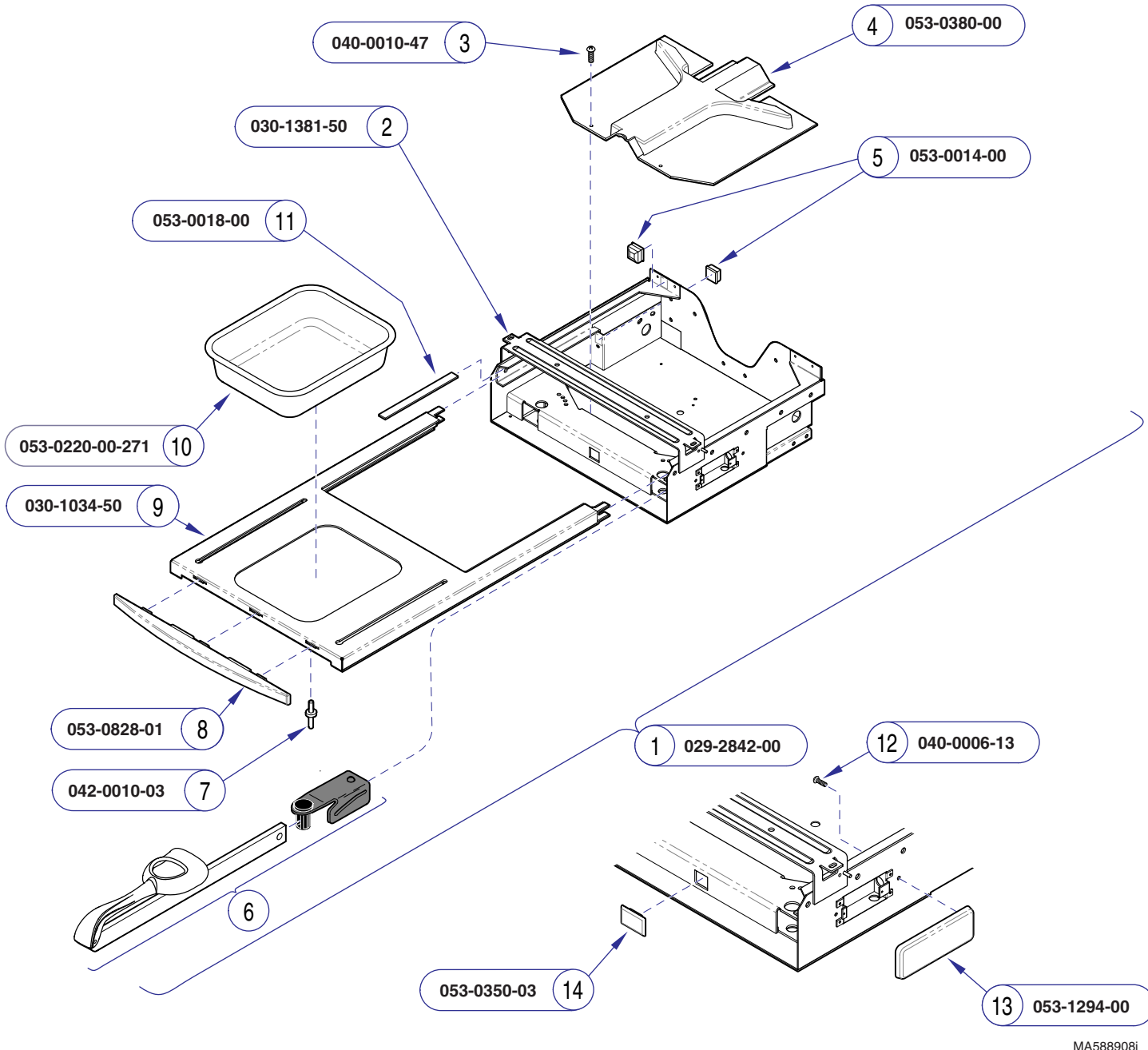

Item	Description	Qty.
1	Upperwrap Assembly (includes items 2 thru 11)	1
2	• Upper Wrap Weldment	1
3	• Screw (10-24 x 3/8")	6
4	• Stirrup Guide	1
5	• Bumper	4
6	• Refer to: "Stirrup Assembly"	2
7	• Pop Rivot	2
8	• Foot Rest Trim	1
9	• Foot Rest Shelf	1
10	• Plastic Treatment Pan	1
11	• Nylon Tape	4
12	Screw (models w/o receptacle)	2
13	Cover (models w/o receptacle)	1
14	Cover (models w/o drawer htr.)	1

Always Specify Model & Serial Number

MA588908i

Models: **222 (-001 thru -010)**
 Serial Numbers: RG1000 thru RG1123 RH1000 thru RH1386
 RJ1000 thru RJ1094 RK1000 thru RK1266
 RL1000 (one table) RM1000 thru RM1015

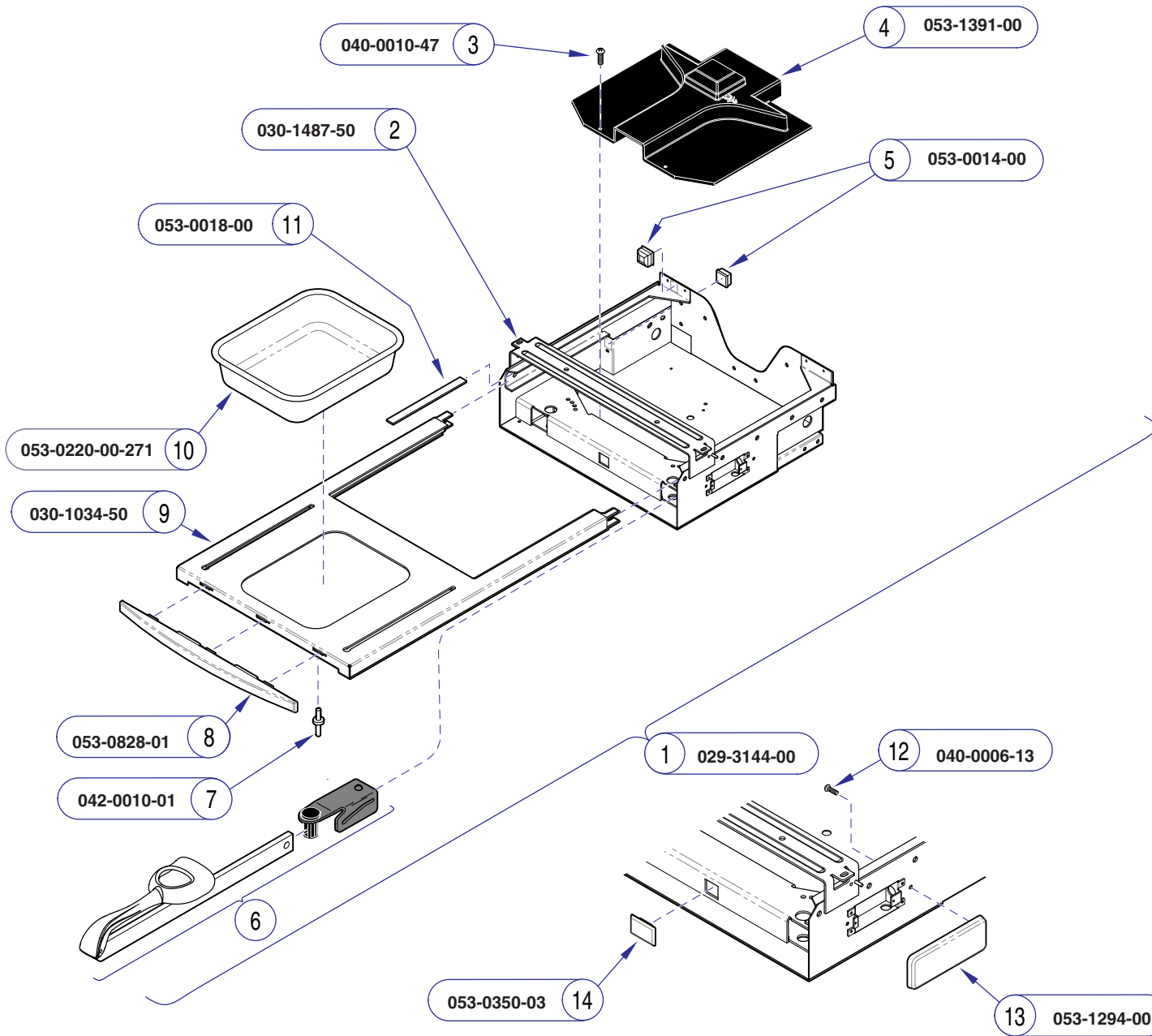

Item	Description	Qty.
1	Upperwrap Assembly (includes items 2 thru 11)	1
2	• Upper Wrap Weldment	1
3	• Screw (10-24 x 3/8")	6
4	• Stirrup Guide	1
5	• Bumper	4
6	• Refer to: "Stirrup Assembly"	2
7	• Pop Rivot	2
8	• Foot Rest Trim	1
9	• Foot Rest Shelf	1
10	• Plastic Treatment Pan	1
11	• Nylon Tape	4
12	Screw (models w/o receptacle)	2
13	Cover (models w/o receptacle)	1
14	Cover (models w/o drawer htr.)	1

Always Specify Model & Serial Number

MA588909I

Models:	222 (-001 thru -014)	223 (-001 thru -014)
Serial Numbers:	RG1124 thru present RJ1095 thru present RL1001 thru present V2200 thru present	RH1387 thru present RK1267 thru present RM1016 thru present All

Ritter Upperwrap & Footrest Shelf

E-15.1

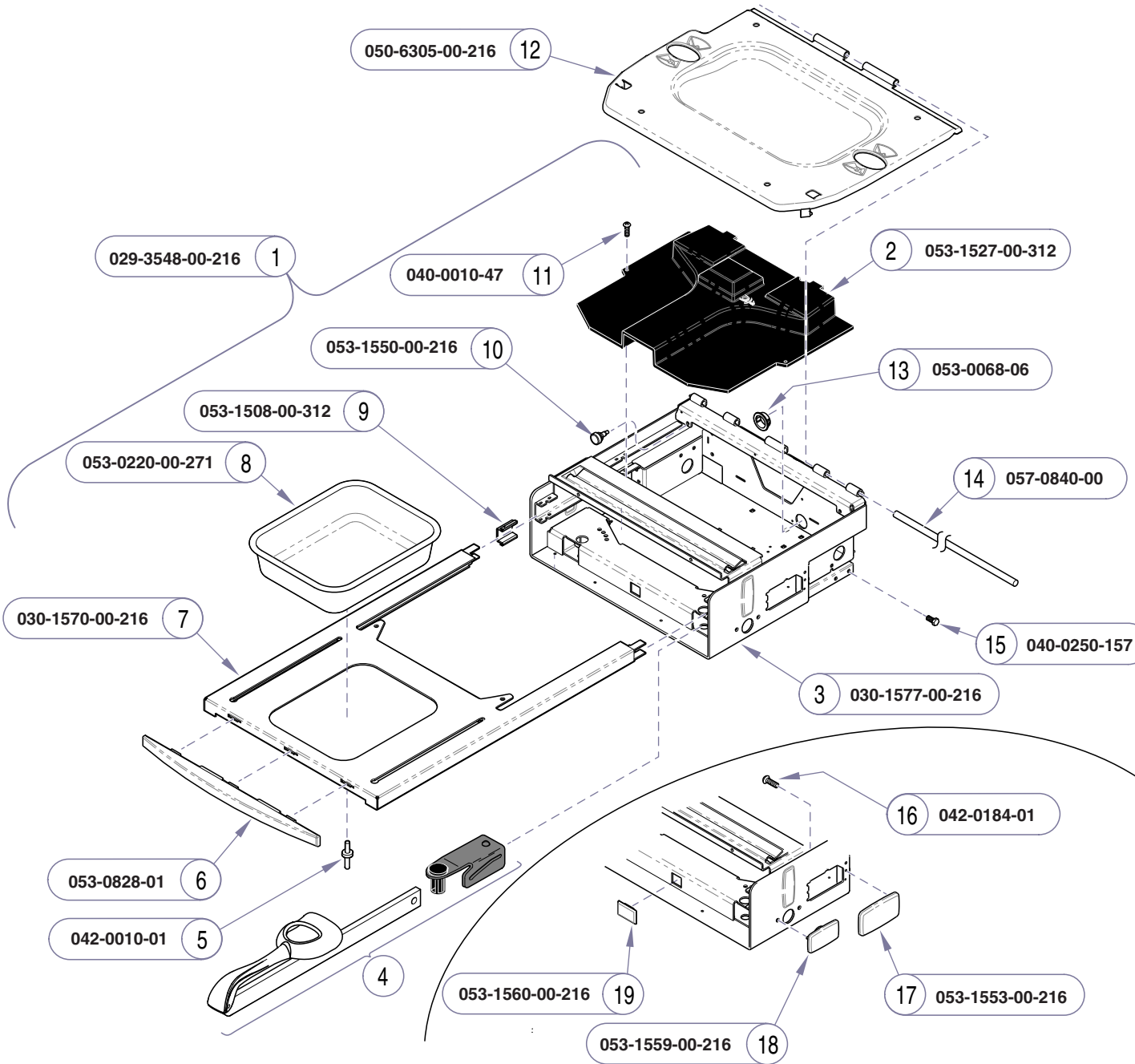

Item	Description	Qty.
1	Upperwrap Assembly (includes items 2 thru 11)	1
2	• Stirrup Guide	1
3	• Upper Wrap Weldment	1
4	• Refer to: "Stirrup Assembly"	2
5	• Pop Rivot	2
6	• Foot Rest Trim	1
7	• Foot Rest Shelf	1
8	• Plastic Treatment Pan	1
9	• Runner Glide	4
10	• Stem Bumper	4
11	• Screw (#10-24 x 3/8")	2
12	Seat Mtg. Frame	1
13	Snap Bushing	3
14	Pivot Rod	1
15	Screw (1/4"-20 x 1/2")	4
Items 16 thru 19 are optional, depending on the table's features:		
16	Screw (10-24 x 3/8")	1
17	Cover (receptacle)	1
18	Cover (accessory socket hole)	1
19	Cover (drawer heater switch)	1

Always Specify Model & Serial Number

MA7118011

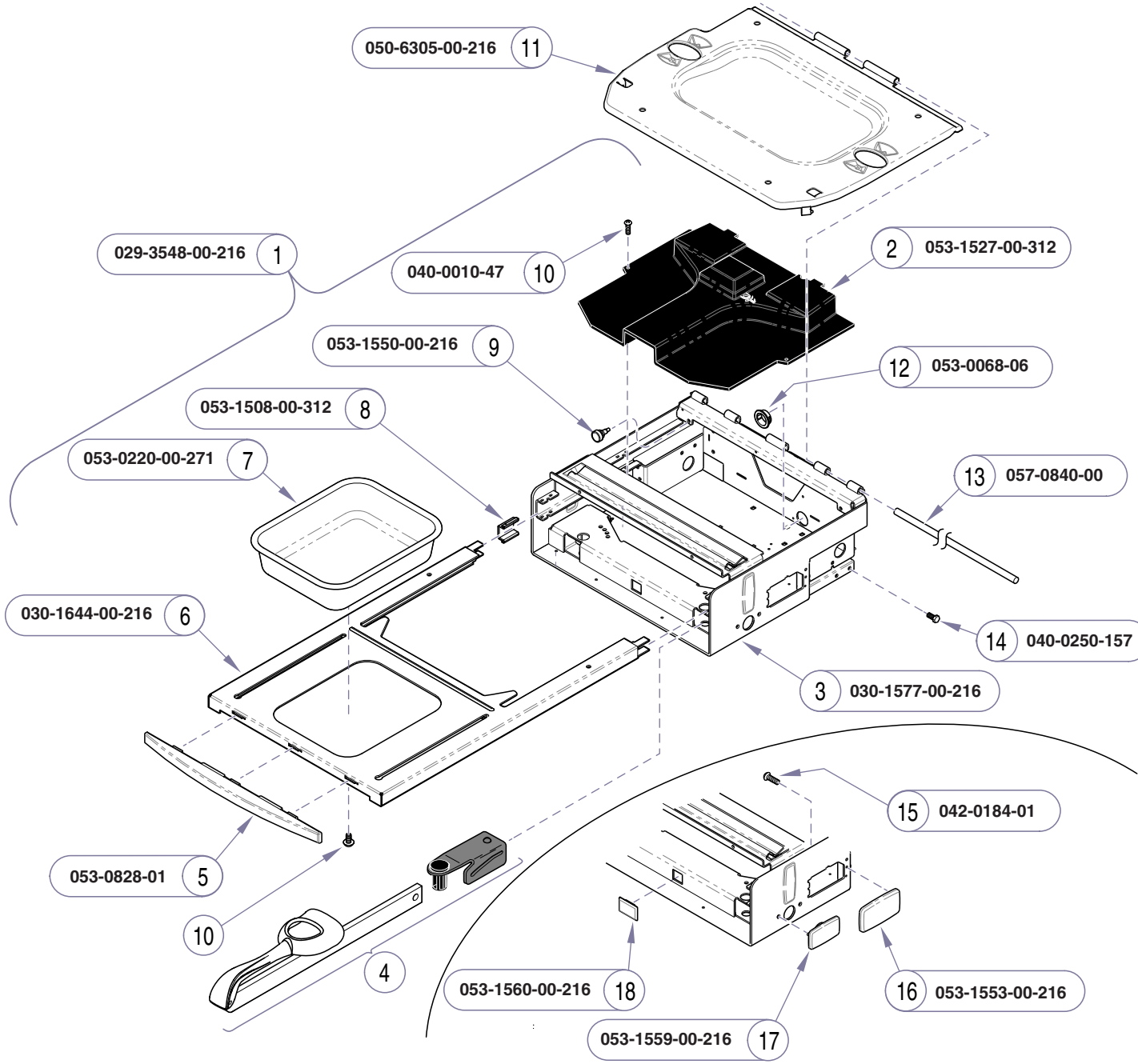

Item	Description	Qty.
1	Upperwrap Assembly (includes items 2 thru 10)	1
2	• Stirrup Guide	1
3	• Upper Wrap Weldment	1
4	• Refer to: "Stirrup Assembly"	2
5	• Foot Rest Trim	1
6	• Foot Rest Shelf	1
7	• Plastic Treatment Pan	1
8	• Runner Glide	4
9	• Stem Bumper	4
10	• Screw (#10-24 x 3/8")	4
11	Seat Mtg. Frame	1
12	Snap Bushing	3
13	Pivot Rod	1
14	Screw (1/4"-20 x 1/2")	4
<i>Items 15 thru 18 are optional, depending on the table's features:</i>		
15	Screw (10-24 x 3/8")	1
16	Cover (receptacle)	1
17	Cover (accessory socket hole)	1
18	Cover (drawer heater switch)	1

Always Specify Model & Serial Number

MA711802I

Models: 222 (-015 thru -017) | 223 (-015 thru -016)
Serial Numbers: V323419 to V816454 | V323419 to V816454

Ritter Upperwrap & Footrest Shelf

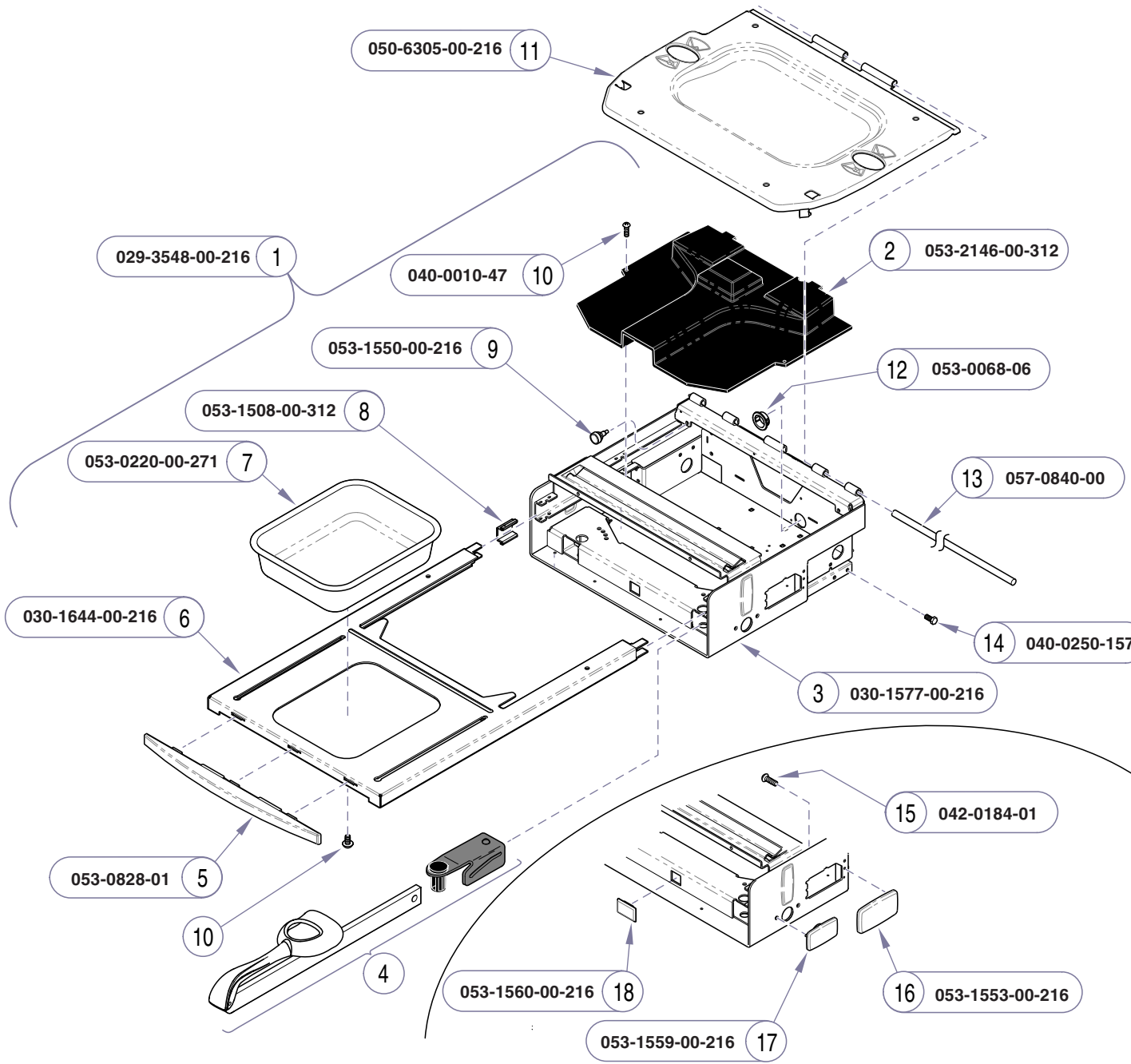

Item	Description	Qty.
1	Upperwrap Assembly (includes items 2 thru 10)	1
2	• Stirrup Guide	1
3	• Upper Wrap Weldment	1
4	• Refer to: "Stirrup Assembly"	2
5	• Foot Rest Trim	1
6	• Foot Rest Shelf	1
7	• Plastic Treatment Pan	1
8	• Runner Glide	4
9	• Stem Bumper	4
10	• Screw (#10-24 x 3/8")	4
11	Seat Mtg. Frame	1
12	Snap Bushing	3
13	Pivot Rod	1
14	Screw (1/4"-20 x 1/2")	4
Items 15 thru 18 are optional, depending on the table's features:		
15	Screw (10-24 x 3/8")	1
16	Cover (receptacle)	1
17	Cover (accessory socket hole)	1
18	Cover (drawer heater switch)	1

Always Specify Model & Serial Number

MA711803i

Ritter Upperwrap & Footrest Shelf

Models: 222 (-015 thru -017) | 223 (-015 thru -016)
Serial Numbers: V816455 thru present | V816455 thru present

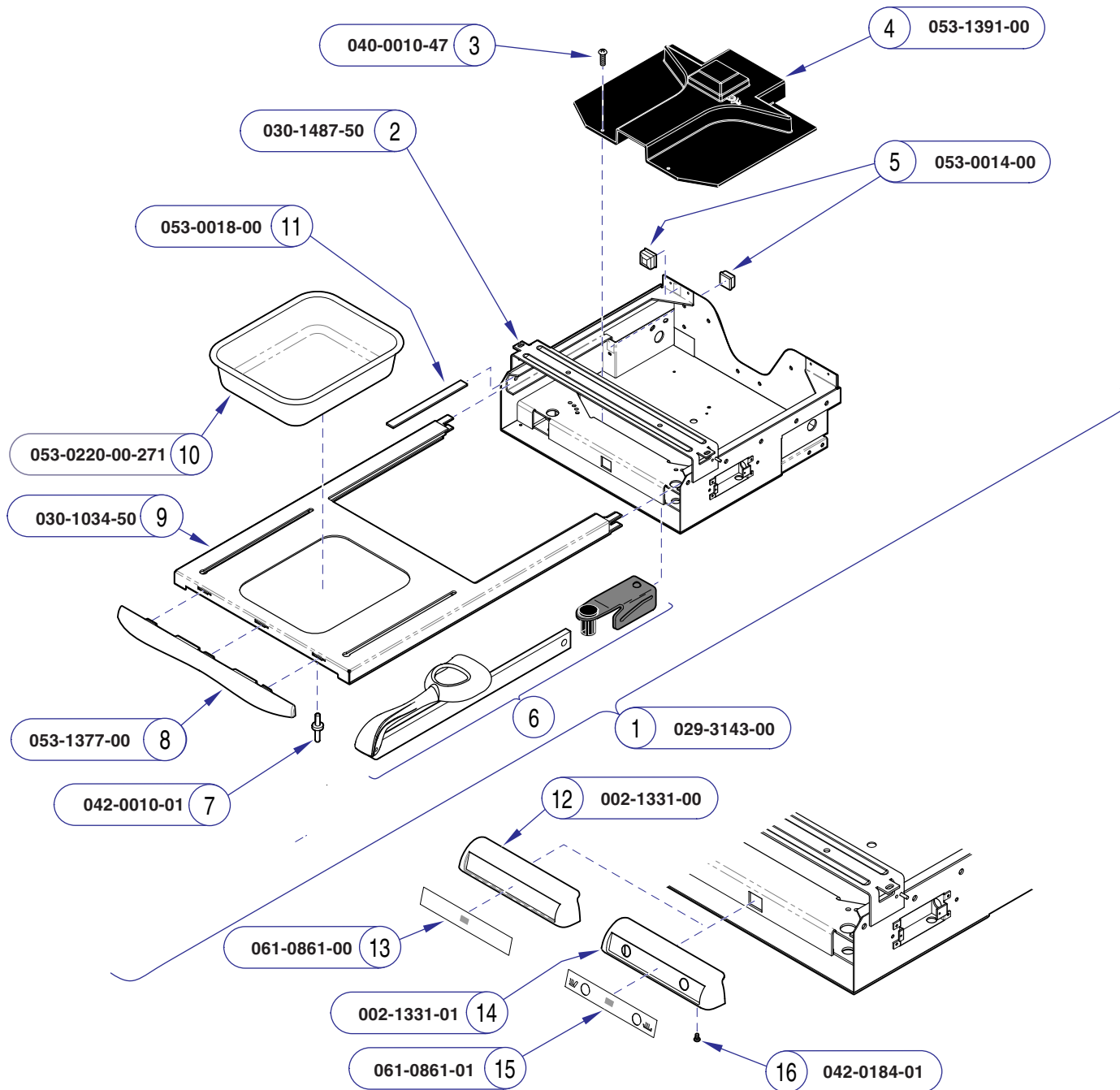

Item	Description	Qty.
1	Upperwrap Assembly (includes items 2 thru 11)	1
2	• Upper Wrap Weldment	1
3	• Screw (10-24 x 3/8")	6
4	• Stirrup Guide	1
5	• Bumper	4
6	• Refer to: "Stirrup Assembly"	2
7	• Pop Rivot	2
8	• Foot Rest Trim	1
9	• Foot Rest Shelf	1
10	• Plastic Treatment Pan	1
11	• Nylon Tape	4
12	Switch Housing and Label Kit (without switch holes [includes label])	1
13	Switch Housing Label (no holes)	1
14	Switch Housing and Label Kit (with two switch holes [includes label])	1
15	Switch Housing Label (two holes)	1
16	Screw (K40 x 12)	2

Always Specify Model & Serial Number

MA5889101

Models: 622 (-001 thru -006) | 623 (-001 thru -006)
Serial Numbers: All | All

Midmark Upperwrap & Footrest Shelf

©Midmark Corporation 2005 SF-1822 Rev. 6/10

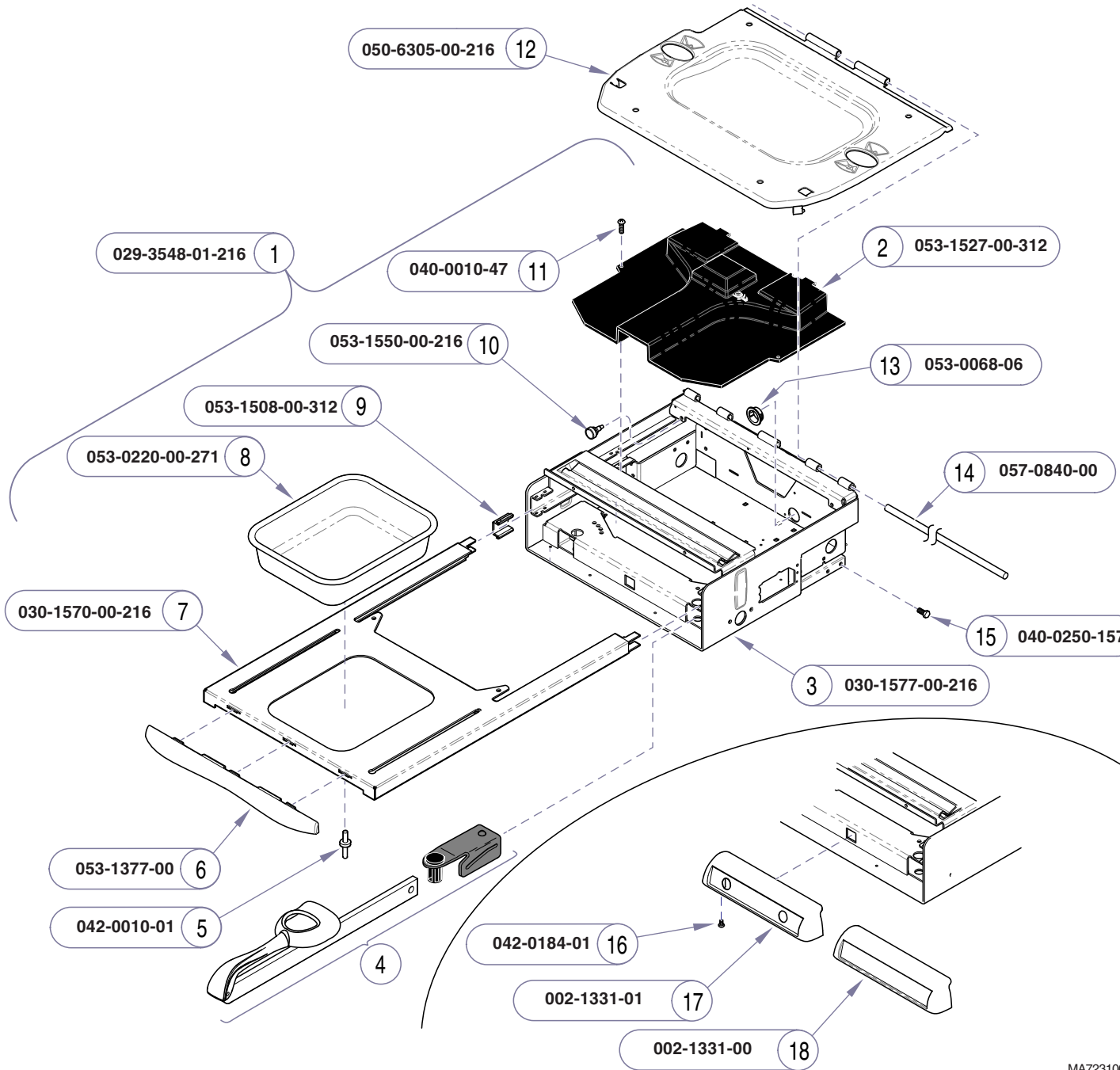

MA723100i

Item	Description	Qty.
1	Upperwrap Assembly (includes items 2 thru 11)	1
2	• Stirrup Guide	1
3	• Upper Wrap Weldment	1
4	• Refer to: "Stirrup Assembly"	2
5	• Pop Rivot	2
6	• Foot Rest Trim	1
7	• Foot Rest Shelf	1
8	• Plastic Treatment Pan	1
9	• Runner Glide	4
10	• Stem Bumper	4
11	• Screw (#10-24 x 3/8")	2
12	Seat Mtg. Frame	1
13	Snap Bushing	3
14	Pivot Rod	1
15	Screw (1/4"-20 x 1/2")	4
16	Screw	2
17	Switch Housing and Label Kit (without switch holes [includes label])	1
18	Switch Housing and Label Kit (with two switch holes [includes label])	1

Always Specify Model & Serial Number

**Midmark Upperwrap &
Footrest Shelf**

Models: 622 (-007 & -008)
Serial Numbers: prior to V323419

623 (-007 thru -010)
prior to V323419

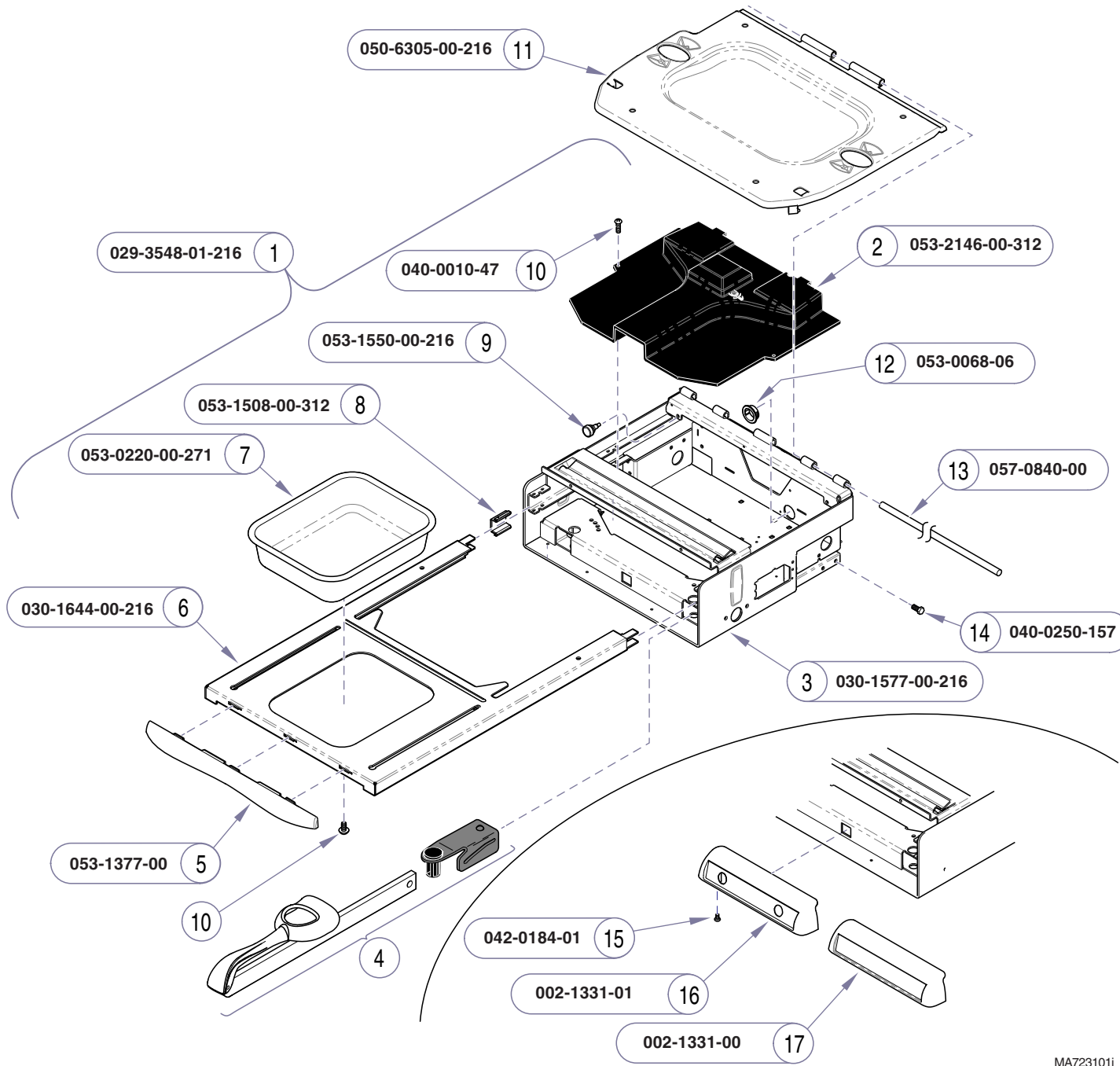

Item	Description	Qty.
1	Upperwrap Assembly <i>(includes items 2 thru 10)</i>	1
2	• Stirrup Guide	1
3	• Upper Wrap Weldment	1
4	• Refer to: "Stirrup Assembly"	2
5	• Foot Rest Trim	1
6	• Foot Rest Shelf	1
7	• Plastic Treatment Pan	1
8	• Runner Glide	4
9	• Stem Bumper	4
10	• Screw (#10-24 x 3/8")	4
11	Seat Mtg. Frame	1
12	Snap Bushing	3
13	Pivot Rod	1
14	Screw (1/4"-20 x 1/2")	4
15	Screw	2
16	Switch Housing and Label Kit <i>(without switch holes [includes label])</i>	1
17	Switch Housing and Label Kit <i>(with two switch holes [includes label])</i>	1

Always Specify Model & Serial Number

MA723101i

Models: 622 (-007 & -008) | 623 (-007 thru -010)
Serial Numbers: V323419 thru present | V323419 thru present

Midmark Upperwrap & Footrest Shelf

Upperwrap & Footrest Shelf:

Ritter models E-15*

Midmark models E-16*

* multiple pages due to model / serial # break

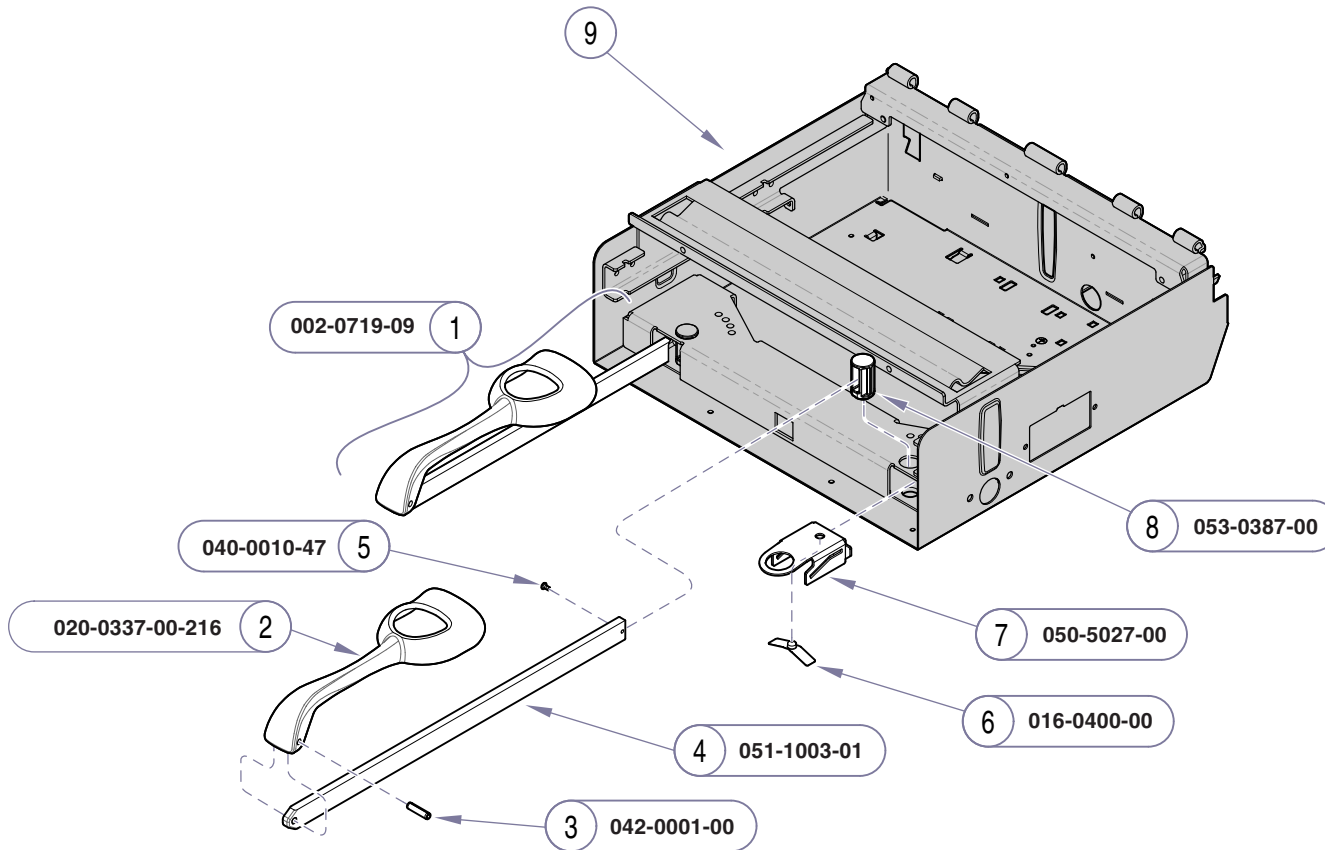

MA7039001

MA7039001

Item	Description	Qty.
1	Stirrup Assembly Set (incl. two assemblies) (includes items 2 thru 4)	1
2	• Stirrup	1
3	• Roll Pin	1
4	• Stirrup Bar	1
5	Screw (#10-24 x 3/8")	2
6	Guide Bracket Spring	2
7	Guide Bracket	2
8	Pivot Boss	2
9	Refer to: "Upperwrap & Footrest Shelf" . Ref	

Always Specify Model & Serial Number

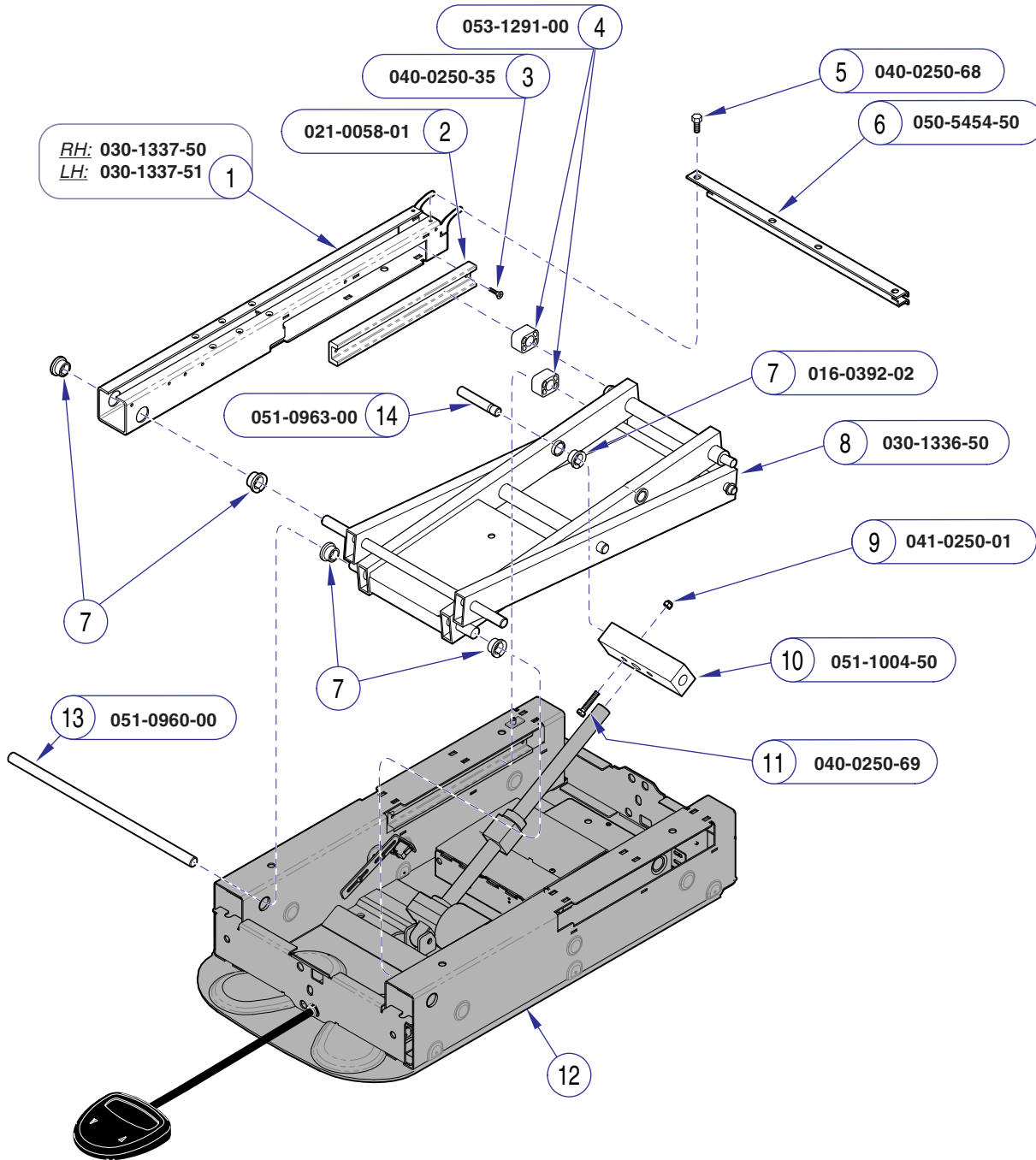

MA588104i

Item	Description	Qty.
1	Scissor Channel Weldment (<i>RH shown</i>)	2
2	Extrusion Slide	2
3	Flat Head Screw (1/4-20 x .5")	4
4	Bearing Guide	4
5	Screw (1/4-20 type F)	2
6	Top Cover Support Channel	1
7	Flange Bearing	8
8	Scissor Arm Weldment Kit.....	1
9	Lock Nut	2
10	Thru Block	1
11	Screw (1/4-20 x 2.25")	2
12	Refer to "Base Components"	Ref
13	Pivot Shaft	1
14	Stub Shaft	2

Always Specify Model & Serial Number

Models: **222 (-001 thru -010)**
 RG1000 thru RG1123 RH1000 thru RH1386
 RJ1000 thru RJ1094 RK1000 thru RK1266
 Serial Numbers: RL1000 (one table) RM1001 (one table)

**Base Scissor / Slide
 Mechanism**

Refer To: **Page**
Base Components:
Ritter models E-19.1*
 * multiple pages due to model / serial # break

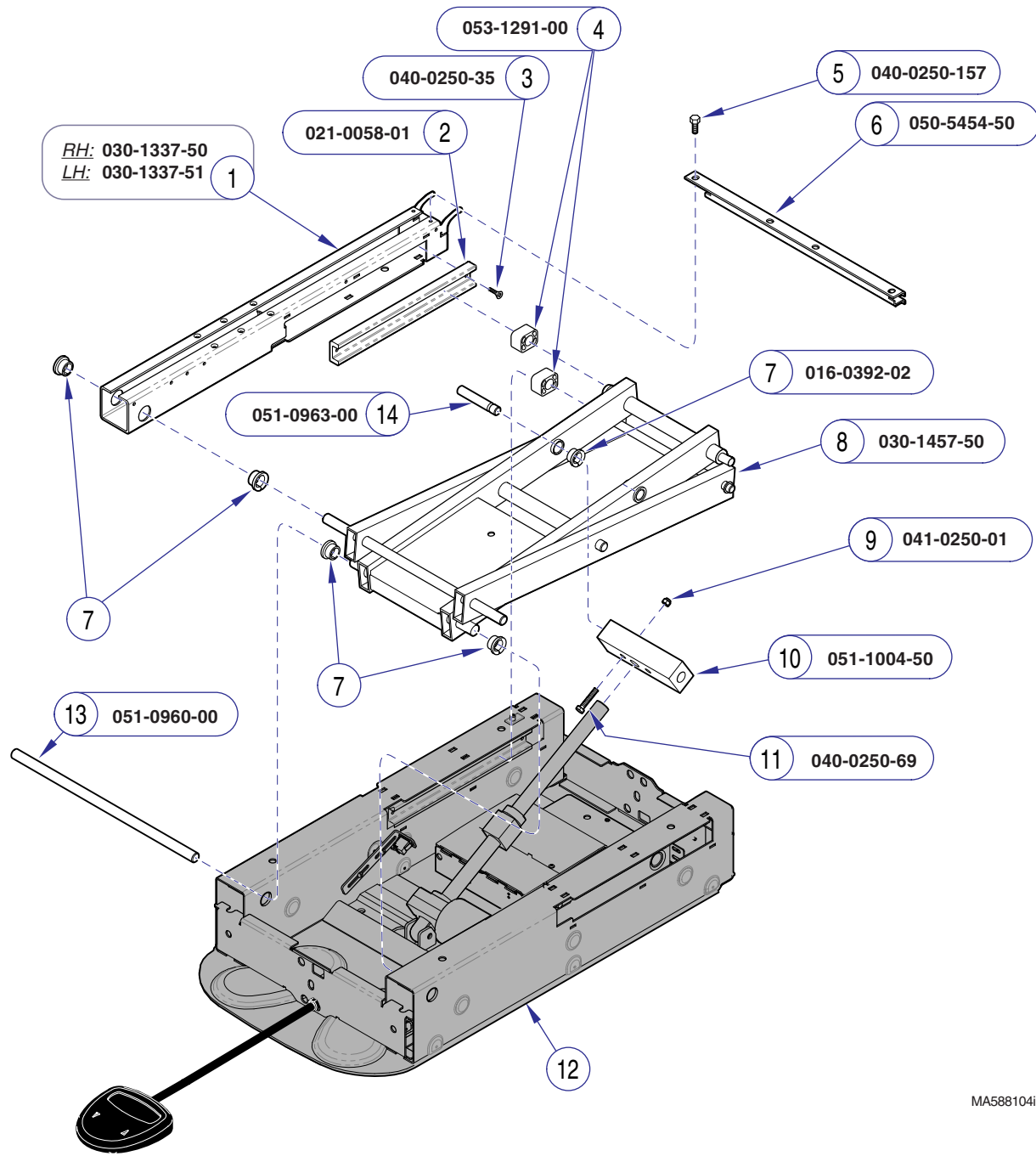

MA588104I

Item	Description	Qty.
1	Scissor Channel Weldment (RH shown)	2
2	Extrusion Slide	2
3	Flat Head Screw (1/4-20 x .5")	4
4	Bearing Guide	4
5	Screw (1/4-20 type F)	2
6	Top Cover Support Channel	1
7	Flange Bearing	8
8	Scissor Arm Weldment Kit	1
9	Lock Nut	2
10	Thru Block	1
11	Screw (1/4-20 x 2.25")	2
12	Refer to "Base Components"	Ref
13	Pivot Shaft	1
14	Stub Shaft	2

Always Specify Model & Serial Number

E-18.1

Base Scissor / Slide Mechanism

Models:
 Serial Numbers: **222 (-001 thru -010)**
 RG1124 thru RG1530 RH1387 thru RH1820
 RJ1095 thru RJ1312 RH1830 (one table)
 RK1267 thru RK1334 RL1001 thru RL1060
 RM1001 thru RM1015

Base Components:

Ritter models E-19.1*

Midmark models E-20*

* multiple pages due to model / serial # break

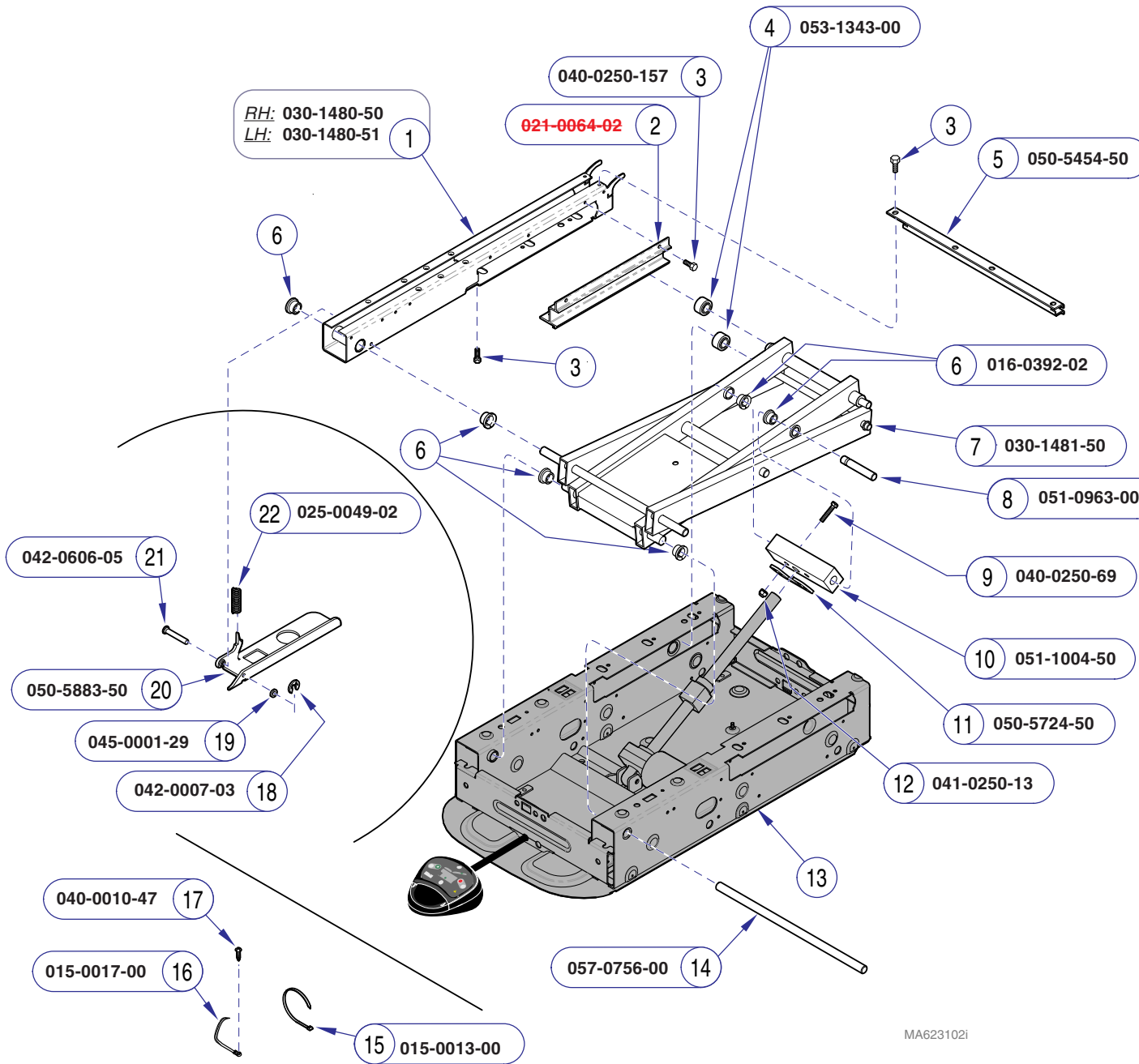

Item	Description	Qty.
1	Scissor Channel Weldment (RH shown)....	2
2	Extrusion Slide	2
3	Flat Head Screw (1/4"-20 x 1/2")	4
4	Bearing Guide	4
5	Top Cover Support Channel	1
6	Flange Bearing	6
7	Scissor Arm Weldment Kit.....	1
8	Stub Shaft	2
9	Screw (1/4"-20 x 2.25").....	2
10	Thru Block	1
11	Thru Block Bracket	1
12	Lock Nut (1/4"-20)	2
13	Refer to "Base Components"	Ref
14	Pivot Shaft	1
15	Cable Tie	1
16	Cable Tie w/screw hole	3
17	Screw (10-24 x .37")	3
<i>Items 18 thru 22 apply only to 623 models</i>		
18	E-clip	1
19	Washer	1
20	Auto-return Switch Strike	1
21	Clevis Pin	1
22	Spring	1

Always Specify Model & Serial Number

MA623102i

Models:	222 (all)	223 (all)	622 (all)	623 (all)	
Serial Numbers:	RH1531 thru present RJ1313 thru present RK1335 thru present RM1016 thru present	RH1821 thru RH1829 RH1831 thru present RL1061 thru present V2200 thru V489138	V2200 thru V489138 & all prefixes: SC, SD, SE, SF, SG, SH	V2200 thru V489138 & all prefixes: SJ, SK, SN, SP	V2200 thru V489138 & all prefixes: SL, SM, SR, SS

Base Scissor / Slide Mechanism

Base Scissor / Slide Mechanism

Models:	222 (-015 thru -017)	223 (-015 & -016)	622 (-007 & -008)	623 (-007 thru -010)
Serial Numbers:	V489139 thru V798445	V489139 thru V798445	V489139 thru V798445	V489139 thru V798445

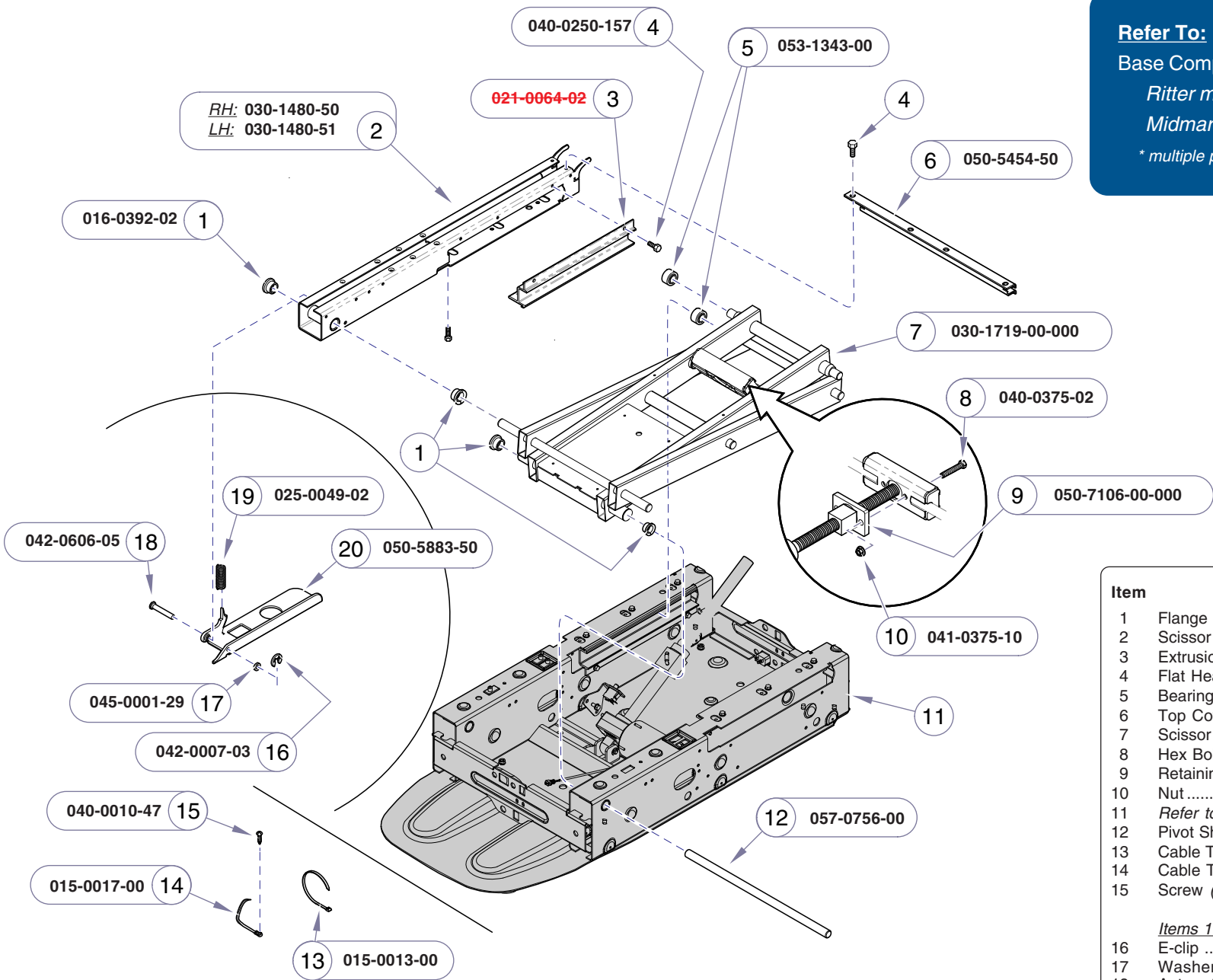

Refer To: Page
Base Components:
Ritter models E-19.1*
Midmark models E-20*
 * multiple pages due to model / serial # break

Item	Description	Qty.
1	Flange Bearing	6?
2	Scissor Channel Weldment (RH shown)	2
3	Extrusion Slide	2
4	Flat Head Screw (1/4-20 x 1/2")	4
5	Bearing Guide	4
6	Top Cover Support Channel	1
7	Scissor Arm Weldment Kit	1
8	Hex Bolt (3/8"-16 x 1 1/4")	2
9	Retaining Plate	1
10	Nut	2
11	Refer to "Base Components"	Ref
12	Pivot Shaft	1
13	Cable Tie	1
14	Cable Tie w/screw hole	3
15	Screw (10-24 x .37")	3
<i>Items 16 thru 20 apply only to 623 models</i>		
16	E-clip	1
17	Washer	1
18	Auto-return Switch Strike	1
19	Clevis Pin	1
20	Spring	1
Always Specify Model & Serial Number		

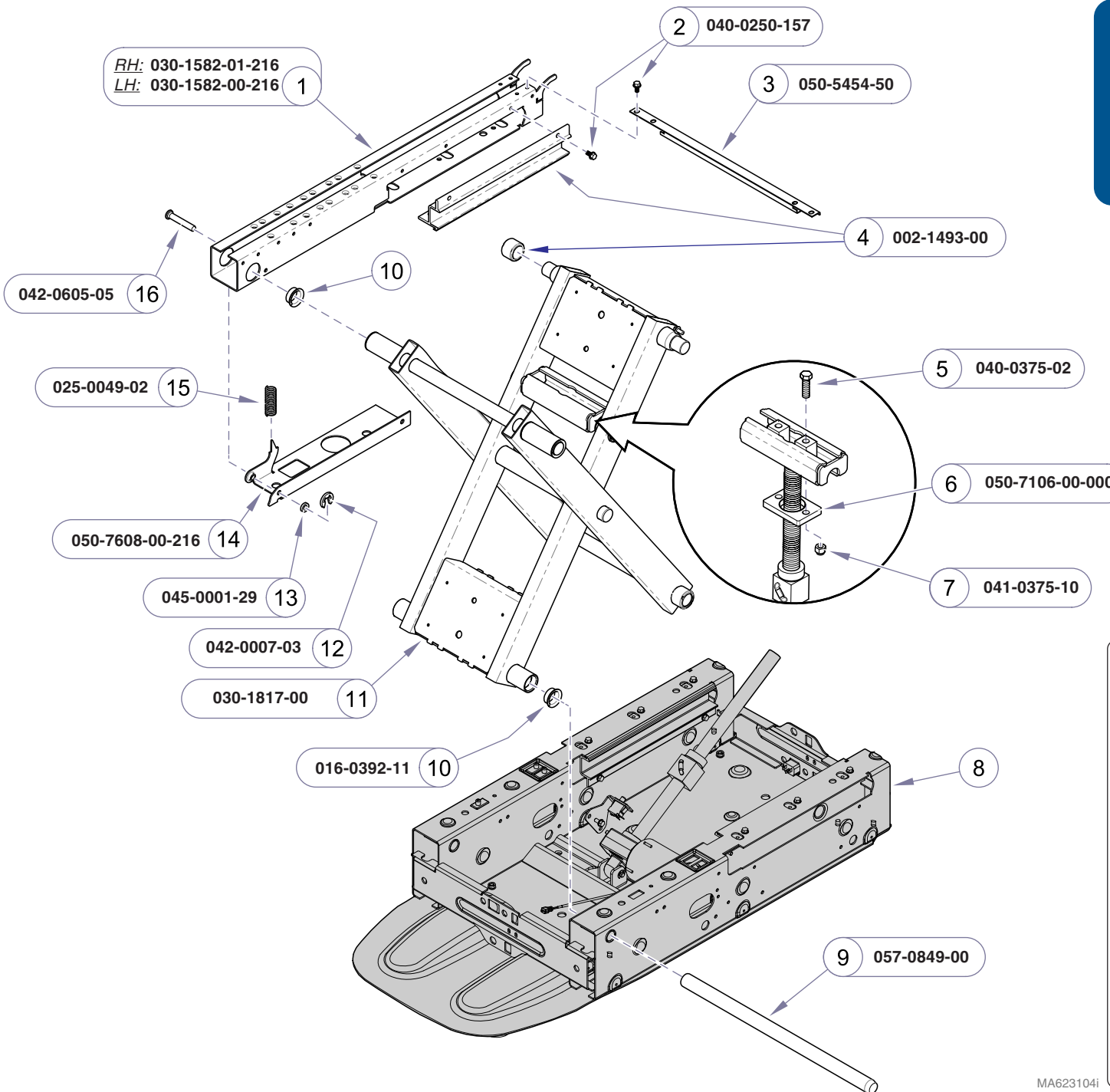

Refer To: **Page**

Base Components:

Ritter models E-19.1*

Midmark models E-20*

* multiple pages due to model / serial # break

Item	Description	Qty.
1	Scissor Channel Weldment (RH shown)	2
2	Flat Head Screw (1/4-20 x 1/2")	4
3	Top Cover Support Channel	1
4	Kit, Scissor Rollers	1
5	Hex Bolt (3/8"-16 x 1 1/4")	2
6	Retaining Plate	1
7	Nut	2
8	Refer to "Base Components"	Ref
9	Pivot Shaft	1
10	Flange Bearing	6
11	Scissor Arm Weldment Kit.....	1
<i>Items 12 thru 16 apply only to 623 models</i>		
12	E-clip	1
13	Washer.....	1
14	Auto-return Switch Strike	1
15	Spring	1
16	Clevis Pin	1

Always Specify Model & Serial Number

Models:	222 (-015 thru -017)	223 (-015 & -016)	622 (-007 & -008)	623 (-007 thru -010)
Serial Numbers:	V798446 thru V897639	V798446 thru V897639	V798446 thru V897639	V798446 thru V897639

Base Scissor / Slide Mechanism

Refer To: **Page**

Base Components:

Ritter models E-19.1*

Midmark models E-20*

* multiple pages due to model / serial # break

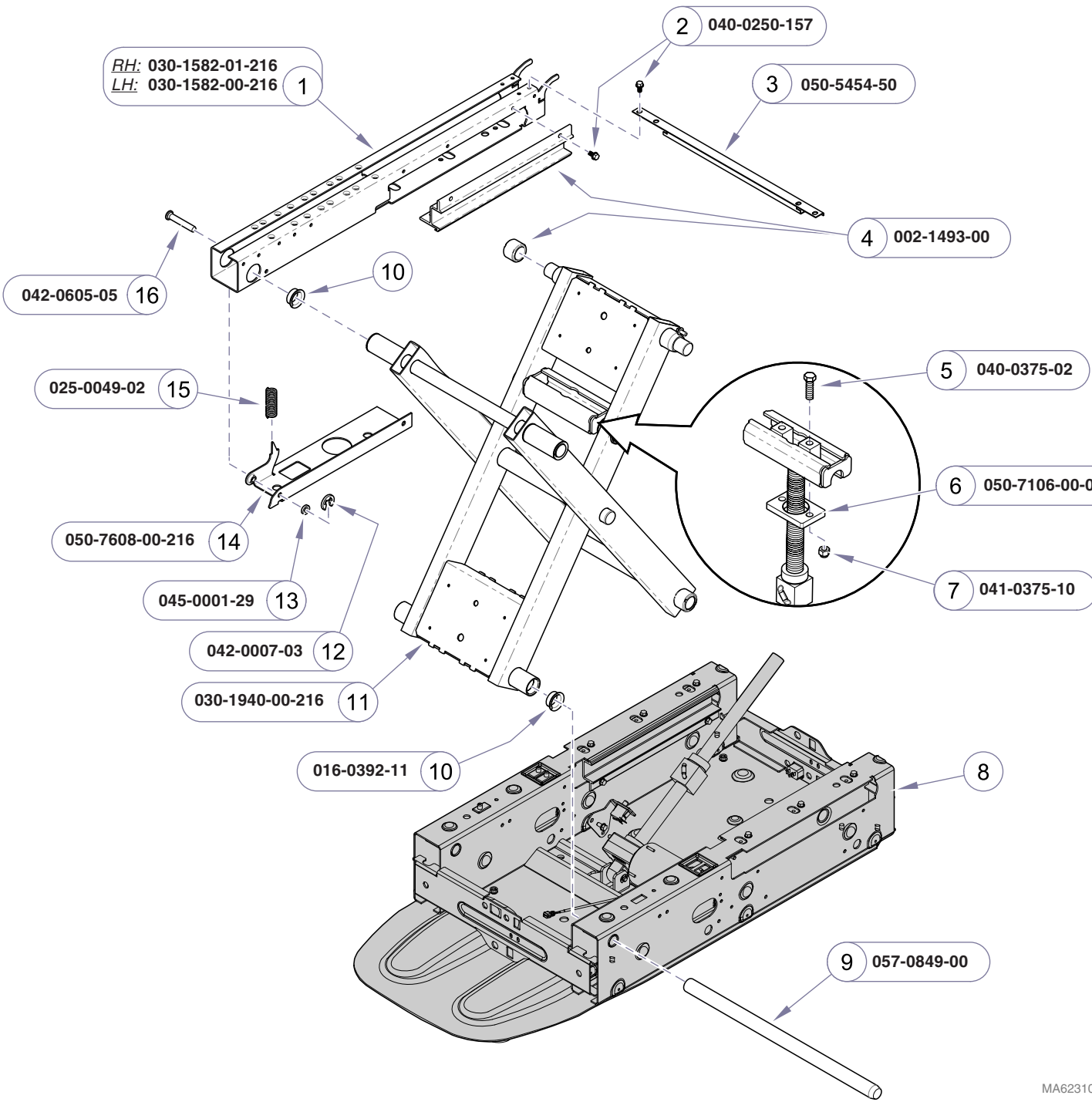

Item	Description	Qty.
1	Scissor Channel Weldment (RH shown)	2
2	Flat Head Screw (1/4-20 x 1/2")	4
3	Top Cover Support Channel	1
4	Kit, Scissor Rollers	1
5	Hex Bolt (3/8"-16 x 1 1/4")	2
6	Retaining Plate	1
7	Nut	2
8	Refer to "Base Components"	Ref
9	Pivot Shaft	1
10	Flange Bearing	6
11	Scissor Arm Weldment Kit	1
<i>Items 12 thru 16 apply only to 623 models</i>		
12	E-clip	1
13	Washer	1
14	Auto-return Switch Strike	1
15	Spring	1
16	Clevis Pin	1
Always Specify Model & Serial Number		

MA623105i

Base Scissor / Slide Mechanism

Models: 222 (-015 thru -017)	223 (-015 & -016)	622 (-007 & -008)	623 (-007 thru -010)
Serial Numbers: V897640 thru V1158421	V897640 thru V1158421	V897640 thru V1158421	V897640 thru V1158421

Base Components:

Ritter models E-19.1*
 Midmark models E-20*
 * multiple pages due to model / serial # break

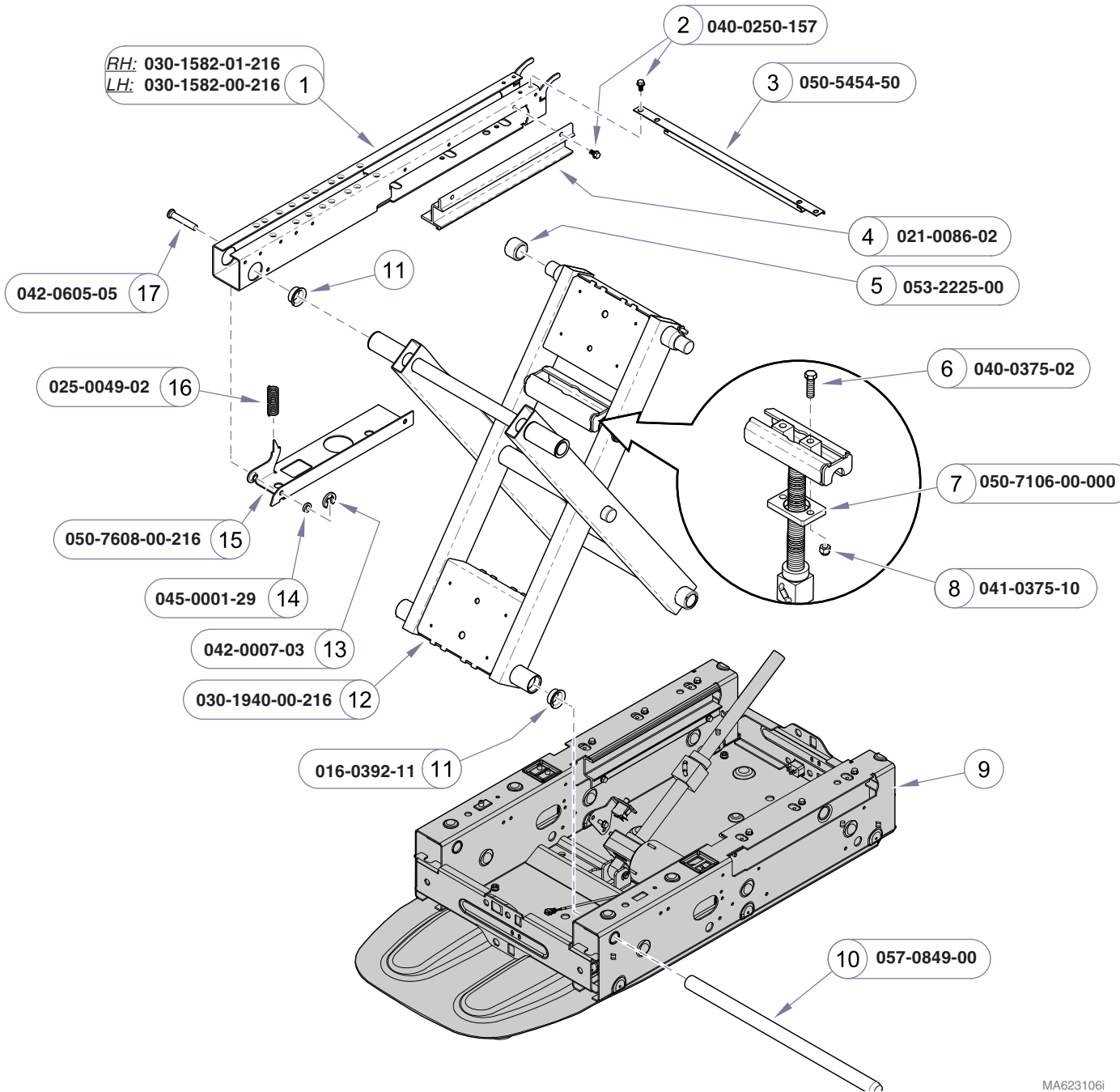

Item	Description	Qty.
1	Scissor Channel Weldment (RH shown)	2
2	Flat Head Screw (1/4-20 x 1/2")	4
3	Top Cover Support Channel	1
4	Slide Extrusion	2
5	Bearing Guide	4
6	Hex Bolt (3/8"-16 x 1 1/4")	2
7	Retaining Plate	1
8	Nut	2
9	Refer to "Base Components"	Ref
10	Pivot Shaft	1
11	Flange Bearing	6
12	Scissor Arm Weldment Kit	1
<i>Items 13 thru 17 apply only to 623 models</i>		
13	E-clip	1
14	Washer	1
15	Auto-return Switch Strike	1
16	Spring	1
17	Clevis Pin	1

Always Specify Model & Serial Number

MA623106i

Models:	222 (-015 thru -017)	223 (-015 & -016)	622 (-007 & -008)	623 (-007 thru -010)
Serial Numbers:	V1158422 thru Present	V1158422 thru Present	V1158422 thru Present	V1158422 thru Present

Base Scissor / Slide Mechanism

This page intentionally left blank.

Refer To: **Page**

Foot Control - 222 / 622	E-26
Base Actuator	E-21
PC Board Enclosure:	
Manual Back models	E-22
Power Cords	E-38

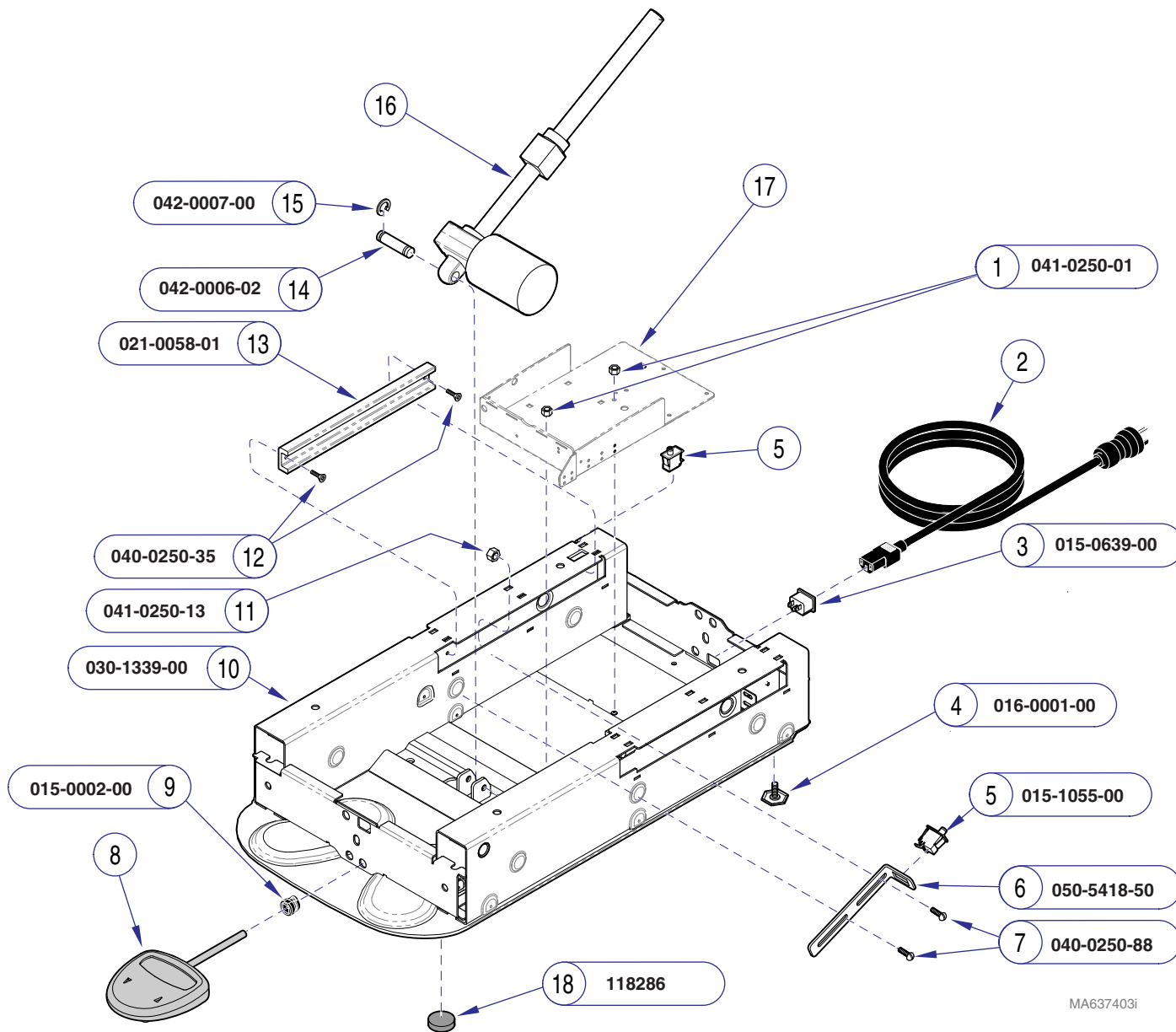

MA637403i

Item	Description	Qty.
1	Nut	2
2	Refer to: "Power Cords"	1
3	IEC Inlet	1
4	Leveling Screw	2
5	Limit Switch	2
6	Limit Switch Bracket	1
7	Screw	2
8	Refer to: "Foot Control"	Ref
9	Strain Relief Bushing	1
10	Base Weldment	1
11	Nut	2
12	Flat Head Screw	4
13	Slide	2
14	Clevis Pin	1
15	E-Ring	2
16	Refer to: "Base Actuator"	Ref
17	Refer to: "PC board Enclosure"	Ref
18	Non-Skid Pad	2

Always Specify Model & Serial Number

Models:	222 (-001 thru -010)
	Serial Numbers: RG1000 thru RG1123 RH1000 thru RH1386 RJ1000 thru RJ1094 RL1000 (one table) RK1000 thru RK1266 RM1000 (one table)

Ritter Base Components

Ritter Base Components

Models: 222 (-001 thru -010)
 Serial Numbers: RG1124 thru RG1530 RH1387 thru RH1821
 RJ1095 thru RJ1312 RH1831 thru RH1832
 RL1001 thru RL1060 RM1001 thru RM1015
 RK1267 thru RK1334

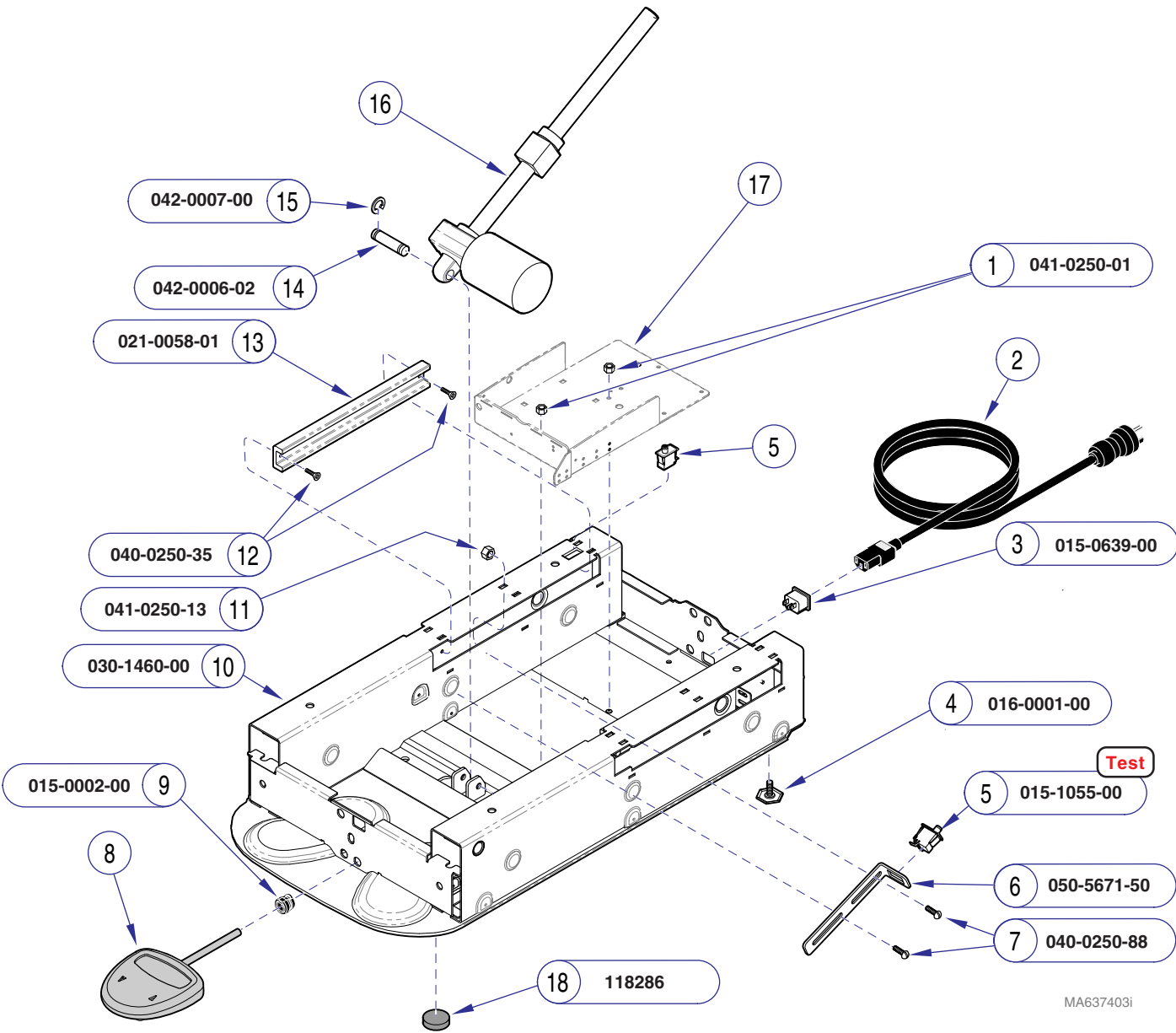

Refer To:	Page
Limit Switch Test	B-5
Foot Control:	
222 / 622	E-26
Base Actuator	E-21
PC Board Enclosure:	
Manual Back models	E-22
Power Cords	E-38

Item	Description	Qty.
1	Nut	2
2	Refer to: "Power Cords"	1
3	IEC Inlet	1
4	Leveling Screw	2
5	Limit Switch	2
6	Limit Switch Bracket	1
7	Screw	2
8	Refer to: "Foot Control"	Ref
9	Strain Relief Bushing	1
10	Base Weldment	1
11	Nut	2
12	Flat Head Screw	4
13	Slide	2
14	Clevis Pin	1
15	E-Ring	2
16	Refer to: "Base Actuator"	Ref
17	Refer to: "PC board Enclosure"	Ref
18	Non-Skid Pad	2

Always Specify Model & Serial Number

MA637403i

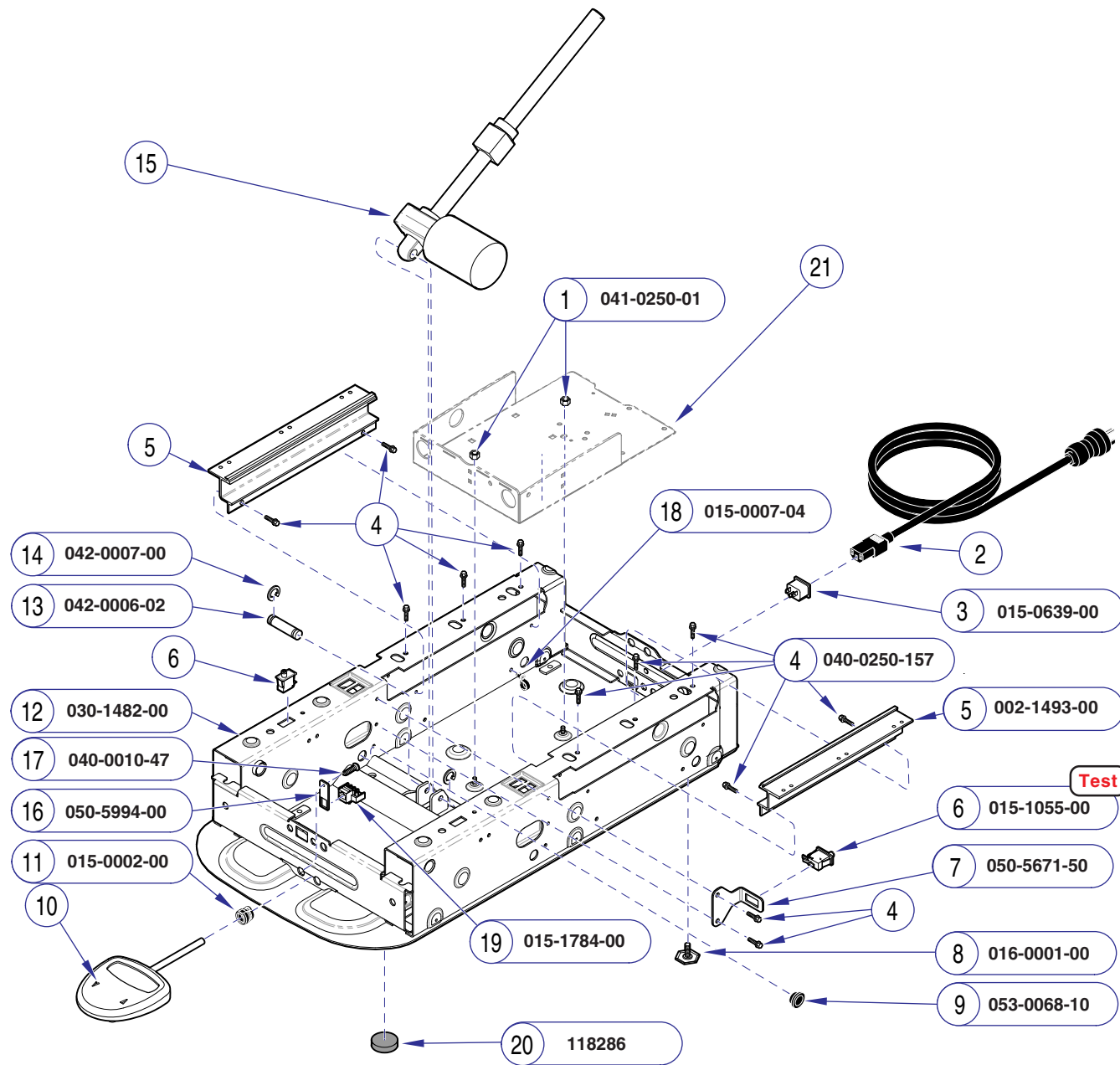

MA637404i

Refer To:	Page
Limit Switch Test	B-5
Foot Control:	
222 / 622	E-26
223	E-27*
Base Actuator	E-21
PC Board Enclosure:	
Manual Back models	E-22
Power Back models	E-23
Power Cords	E-38
* multiple pages due to model / serial # break	

Item	Description	Qty.
1	Nut	2
2	Refer to: "Power Cords"	1
3	IEC Inlet	1
4	Screw	12
5	Kit, Scissor Rollers	1
6	Limit Switch	2
7	Limit Switch Bracket	1
8	Leveling Screw	2
9	Snap Bushing	1
10	Refer to: "Foot Control"	Ref
11	Strain Relief Bushing (222 only)	1
12	Base Weldment	1
13	Clevis Pin	1
14	E-Ring	2
15	Refer to: "Base Actuator"	Ref
16	Modular Plug Adapter Plate (223 only)	1
17	Screw (223 only)	1
18	Wrap-N-Tap Wire Clamp	3
19	Modular Plug (223 Only)	1
20	Non-Skid Pad	2
21	Refer to: "PC board Enclosure"	Ref

Always Specify Model & Serial Number

Models:	222 (-001 thru -014)	223 (-001 thru -014)
Serial Numbers:	RG1531 thru present RJ1313 thru present RL1061 thru present RK1335 thru present	RH1822 thru RH1830 RH1833 thru present RM1016 thru present V2200 thru V58430
		SC1000 thru present SE1000 thru present V2200 thru V58430
		SD1000 thru present SF1000 thru present

**Ritter Base
Components**

E-19.2

E-19.3

Ritter Base Components

Models:	222 (-001 thru -014)	222 (-017)	223 (-001 thru -014)
Serial Numbers:	V58431 thru V1158421	V58431 thru V1158421	V58431 thru V1158421

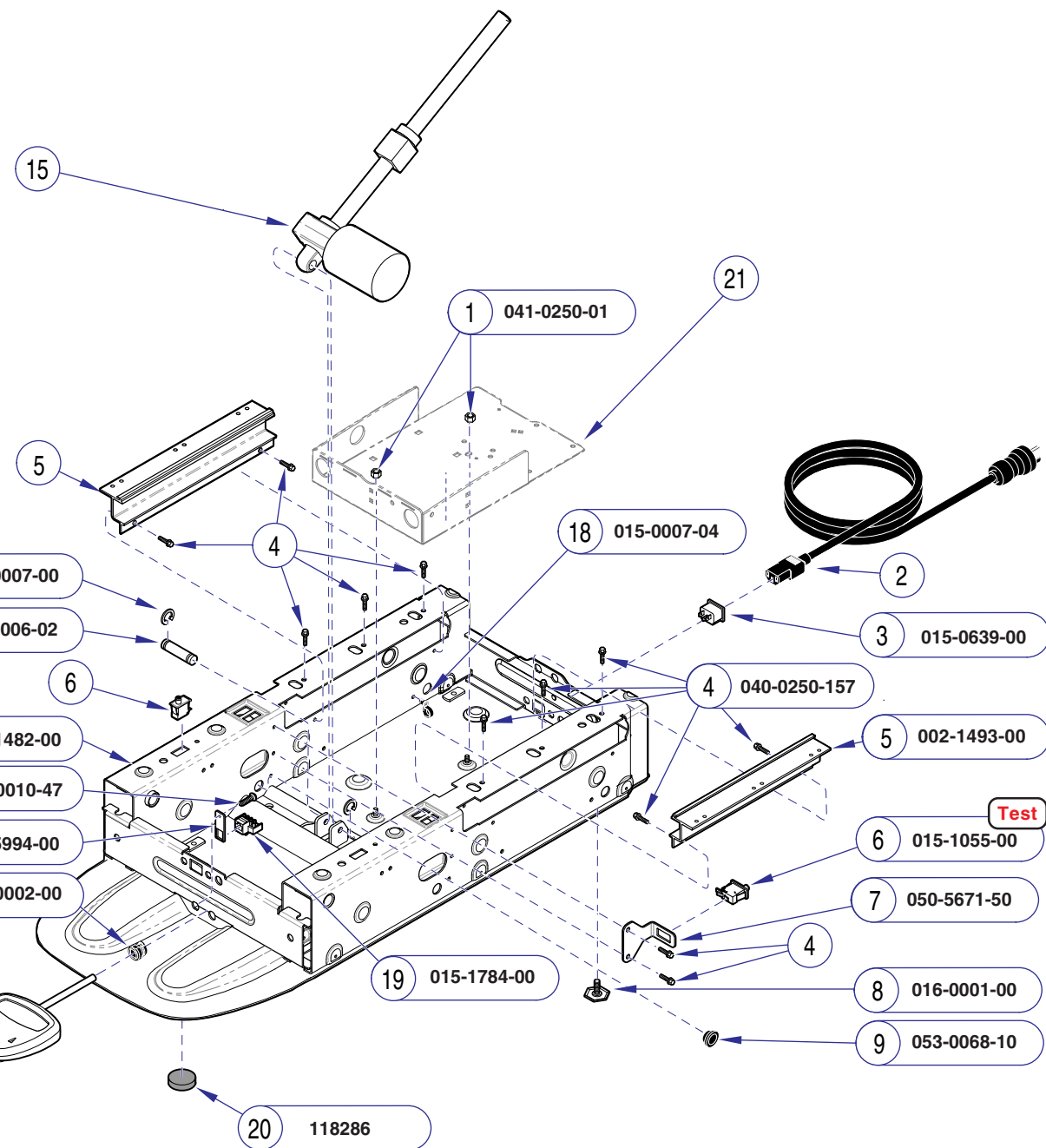

MA637405i

Refer To:	Page
Limit Switch Test	B-5
Foot Control:	
222 / 622	E-26
223	E-27.1
Base Actuator	E-21
PC Board Enclosure:	
Manual Back models	E-22
Power Back models	E-23
Power Cords	E-38

Item	Description	Qty.
1	Nut	2
2	Refer to: "Power Cords"	1
3	IEC Inlet	1
4	Screw	12
5	Kit, Scissor Rollers	1
6	Limit Switch	2
7	Limit Switch Bracket	1
8	Leveling Screw	2
9	Snap Bushing	1
10	Refer to: "Foot Control"	Ref
11	Strain Relief Bushing (222 only)	1
12	Base Weldment	1
13	Clevis Pin	1
14	E-Ring	2
15	Refer to: "Base Actuator"	Ref
16	Modular Plug Adapter Plate (223 only)	1
17	Screw (223 only)	1
18	Wrap-N-Tap Wire Clamp	3
19	Modular Plug (223 Only)	1
20	Non-Skid Pad	2
21	Refer to: "PC board Enclosure"	Ref

Always Specify Model & Serial Number

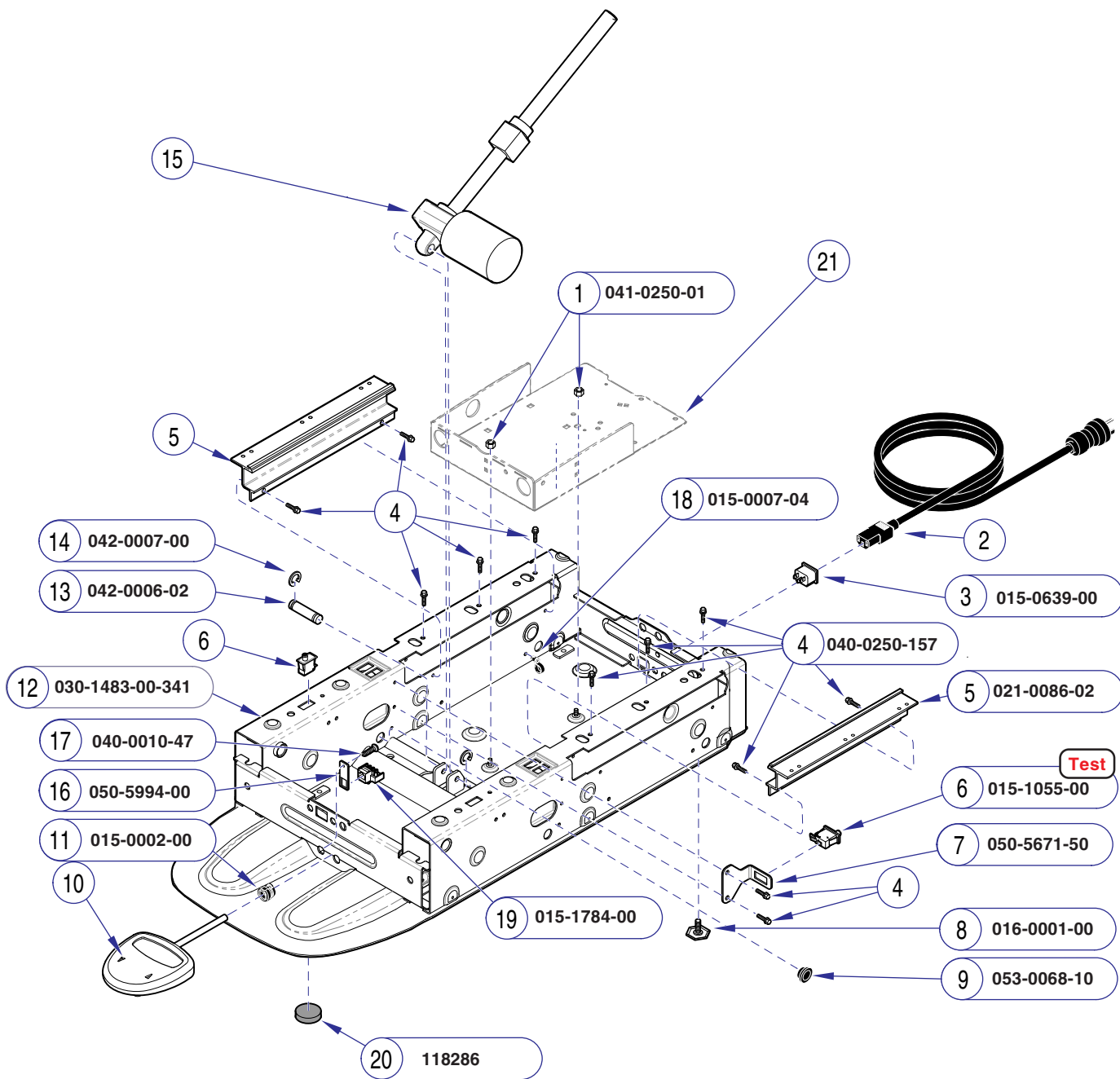

Refer To:	Page
Limit Switch Test	B-5
Foot Control:	
222 / 622	E-26
223	E-27.1
Base Actuator	E-21
PC Board Enclosure:	
Manual Back models	E-22
Power Back models	E-23
Power Cords	E-38

Item	Description	Qty.
1	Nut	2
2	Refer to: "Power Cords"	1
3	IEC Inlet	1
4	Screw	12
5	Slide Extrusion	2
6	Limit Switch	2
7	Limit Switch Bracket	1
8	Leveling Screw	2
9	Snap Bushing	1
10	Refer to: "Foot Control"	Ref
11	Strain Relief Bushing (222 only)	1
12	Base Weldment	1
13	Clevis Pin	1
14	E-Ring	2
15	Refer to: "Base Actuator"	Ref
16	Modular Plug Adapter Plate (223 only)	1
17	Screw (223 only)	1
18	Wrap-N-Tap Wire Clamp	3
19	Modular Plug (223 Only)	1
20	Non-Skid Pad	2
21	Refer to: "PC board Enclosure"	Ref

Test

Always Specify Model & Serial Number

MA637405-1i

Models:	222 (-001 thru -014)	222 (-017)	223 (-001 thru -014)
Serial Numbers:	V1158422 thru V1182653	V1158422 thru V1182653	V1158422 thru V1182653

**Ritter Base
Components**

Ritter Base Components

Models: 222 (-015 & -016)
Serial Numbers: V58431 thru V798445

Models: 223 (-015 & -016)
Serial Numbers: V58431 thru V798445

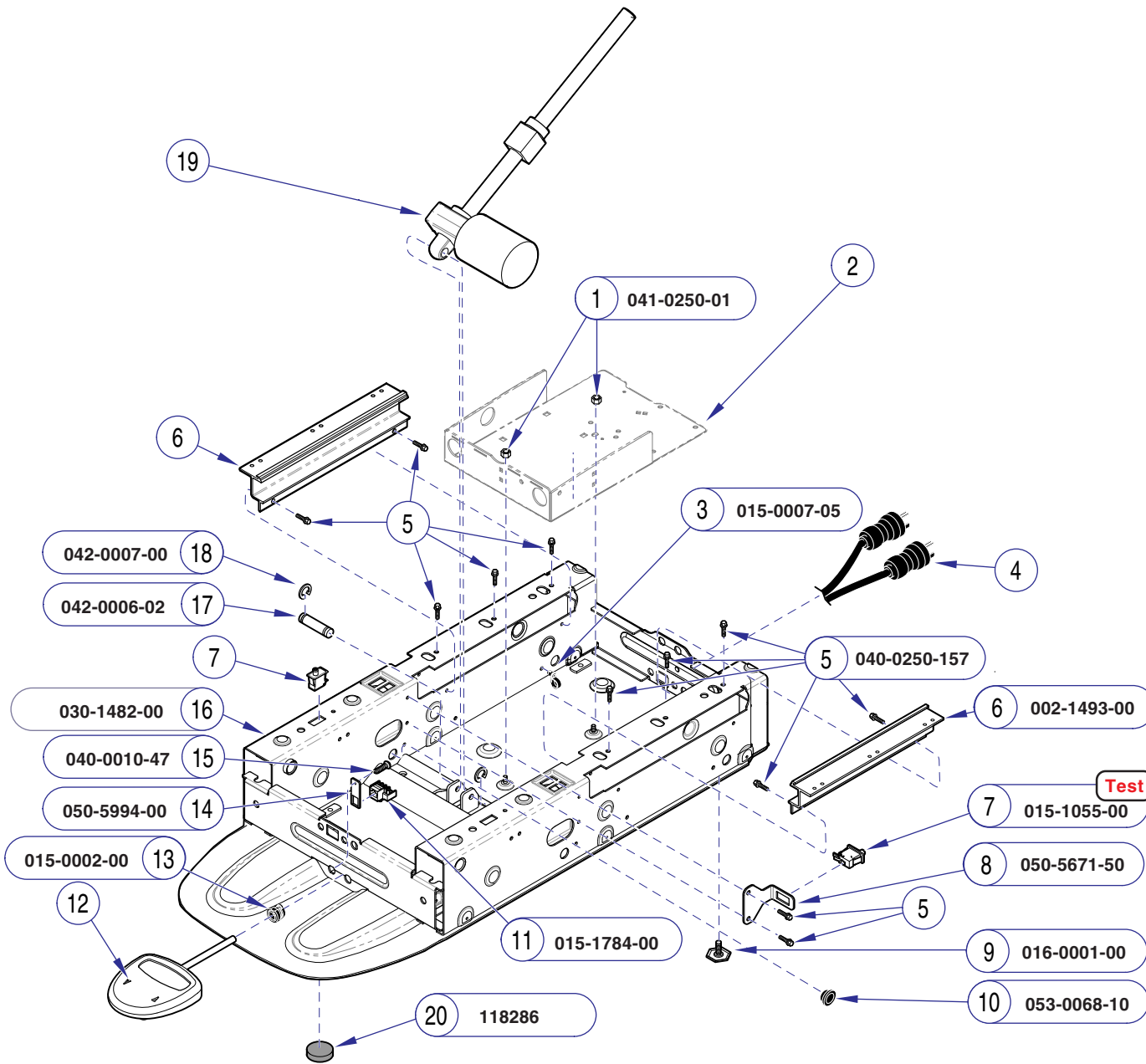

MA637406i

Refer To:	Page
Limit Switch Test	B-5
Section D - Wiring Diagrams	D-1
Foot Control:	
222 / 622	E-26
223	E-27.1
Base Actuator	E-21
PC Board Enclosure:	
Manual Back models	E-22
Power Back models	E-23
Power Cords	E-38

Item	Description	Qty.
1	Nut	2
2	Refer to: "PC board Enclosure"	Ref
3	Wrap-N-Tap Wire Clamp	3
4	Refer to: "Power Cords"	1
5	Screw	12
6	Kit, Scissor Roller	1
7	Limit Switch	2
8	Limit Switch Bracket	1
9	Leveling Screw	2
10	Snap Bushing	1
11	Modular Plug (223 Only)	1
12	Refer to: "Foot Control"	Ref
13	Strain Relief Bushing (222 only)	1
14	Modular Plug Adapter Plate (223 only)	1
15	Screw (223 only)	1
16	Base Weldment	1
17	Clevis Pin	1
18	E-Ring	2
19	Refer to: "Base Actuator"	Ref
20	Non-Skid Pad	2

Always Specify Model & Serial Number

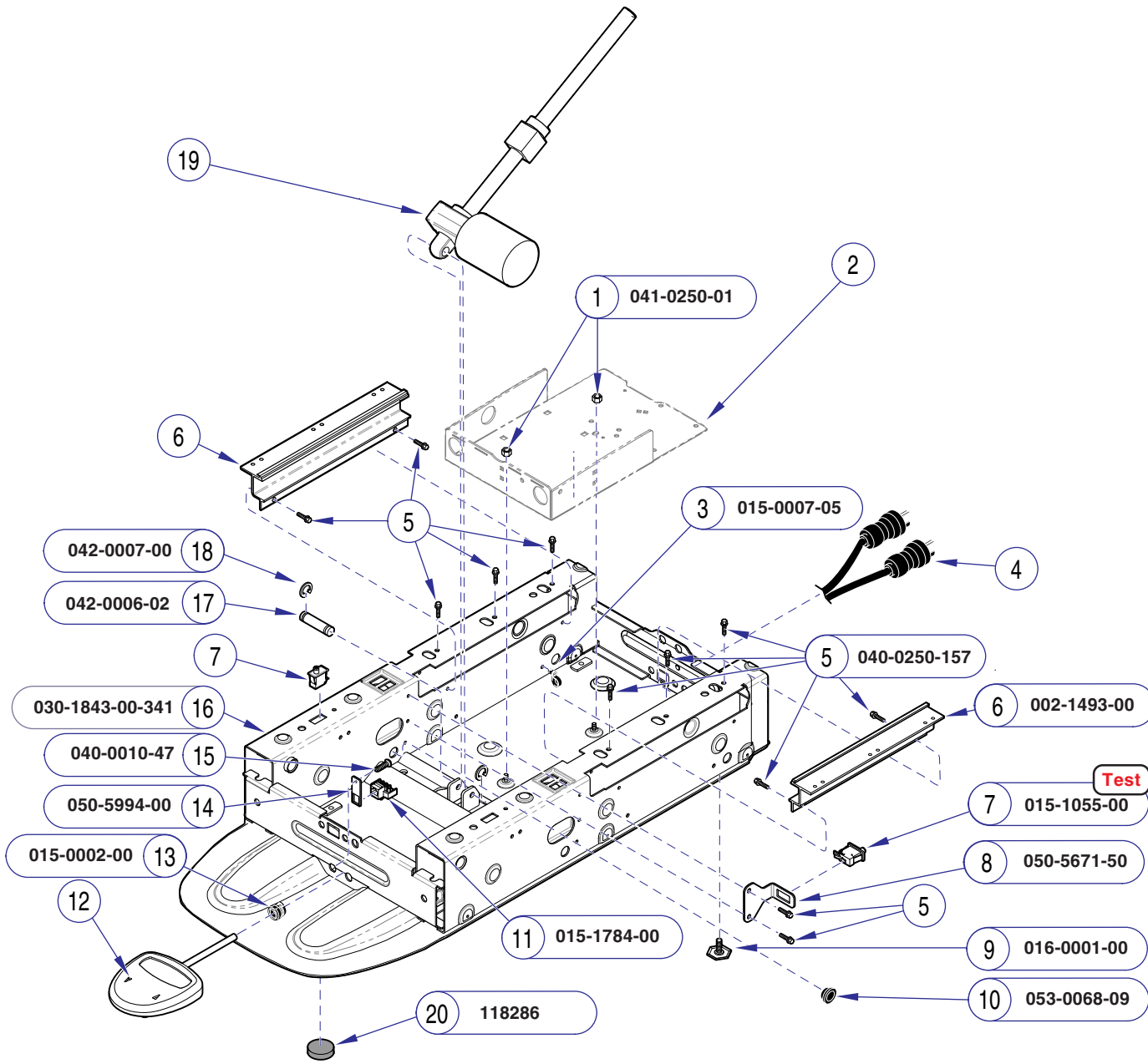

MA637406i

Refer To:	Page
Limit Switch Test Test	B-5
Section D - Wiring Diagrams	D-1
Foot Control:	
222 / 622	E-26
223	E-27.1
Base Actuator	E-21
PC Board Enclosure:	
Manual Back models	E-22
Power Back models	E-23
Power Cords	E-38

Item	Description	Qty.
1	Nut	2
2	Refer to: "PC board Enclosure"	Ref
3	Wrap-N-Tap Wire Clamp	3
4	Refer to: "Power Cords"	1
5	Screw	12
6	Kit, Scissor Rollers	1
7	Limit Switch	2
8	Limit Switch Bracket	1
9	Leveling Screw	2
10	Snap Bushing	1
11	Modular Plug (223 Only)	1
12	Refer to: "Foot Control"	Ref
13	Strain Relief Bushing (222 only)	1
14	Modular Plug Adapter Plate (223 only)	1
15	Screw (223 only)	1
16	Base Weldment	1
17	Clevis Pin	1
18	E-Ring	2
19	Refer to: "Base Actuator"	Ref
20	Non-Skid Pad	2

Always Specify Model & Serial Number

Models:	222 (-015 & -016)	223 (-015 & -016)
Serial Numbers:	V798446 thru V1158421	V798446 thru V1158421

Ritter Base Components

Ritter Base Components

Models: 222 (-015 & -016) | 223 (-015 & -016)
Serial Numbers: V1158422 thru V1182653 | V1158422 thru V1182653

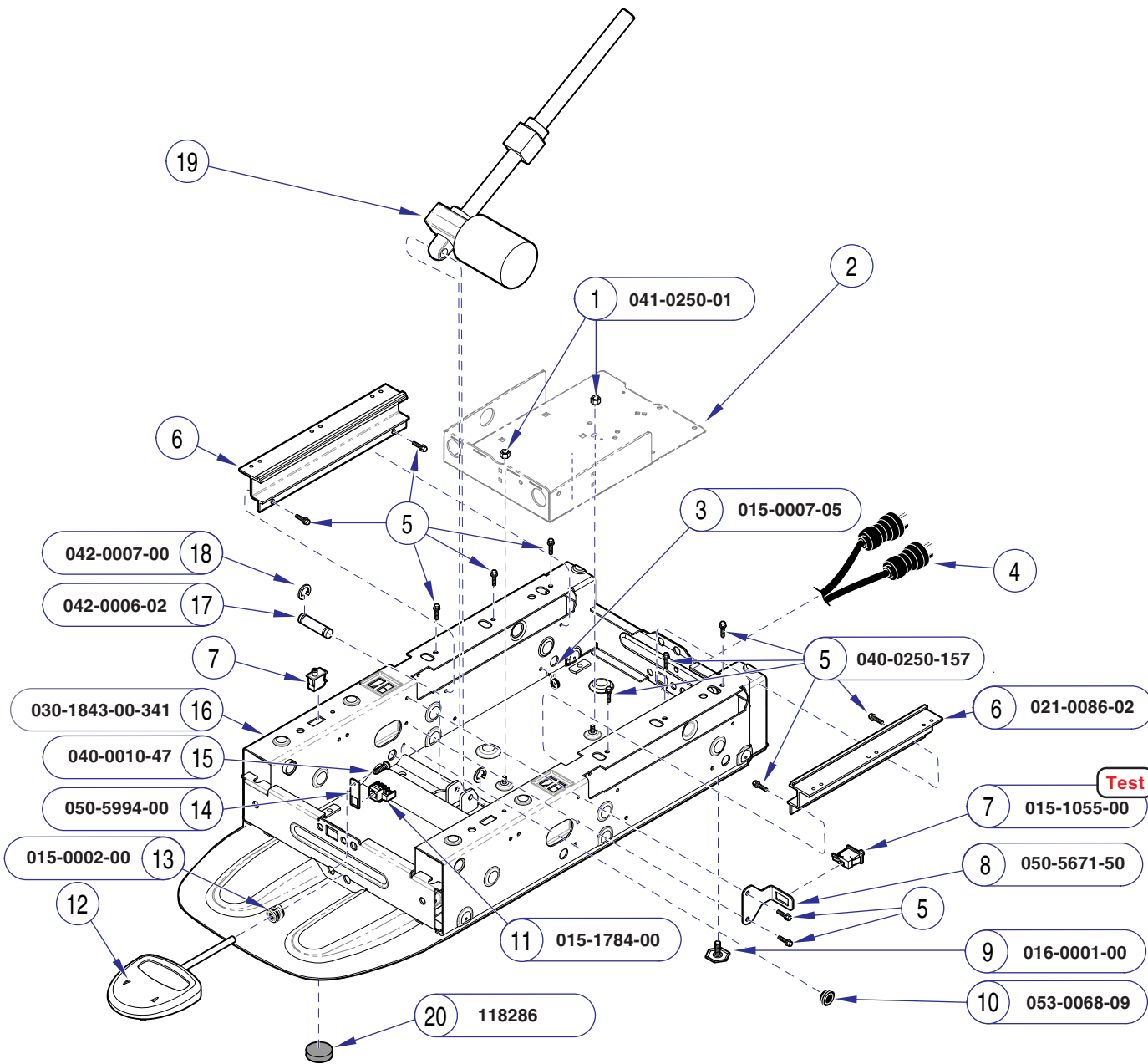

MA637406-1i

Refer To: **Page**

Limit Switch **Test** B-5

Section D - Wiring Diagrams D-1

Foot Control:

222 / 622 E-26

223 E-27.1

Base Actuator E-21

PC Board Enclosure:

Manual Back models E-22

Power Back models E-23

PowerCords E-38

Item	Description	Qty.
1	Nut	2
2	Refer to: "PC board Enclosure"	Ref
3	Wrap-N-Tap Wire Clamp	3
4	Refer to: "Power Cords"	1
5	Screw	12
6	Slide Extrusion	2
7	Limit Switch	2
8	Limit Switch Bracket	1
9	Leveling Screw	2
10	Snap Bushing	1
11	Modular Plug (223 Only)	1
12	Refer to: "Foot Control"	Ref
13	Strain Relief Bushing (222 only)	1
14	Modular Plug Adapter Plate (223 only)	1
15	Screw (223 only)	1
16	Base Weldment	1
17	Clevis Pin	1
18	E-Ring	2
19	Refer to: "Base Actuator"	Ref
20	Non-Skid Pad	2

Always Specify Model & Serial Number

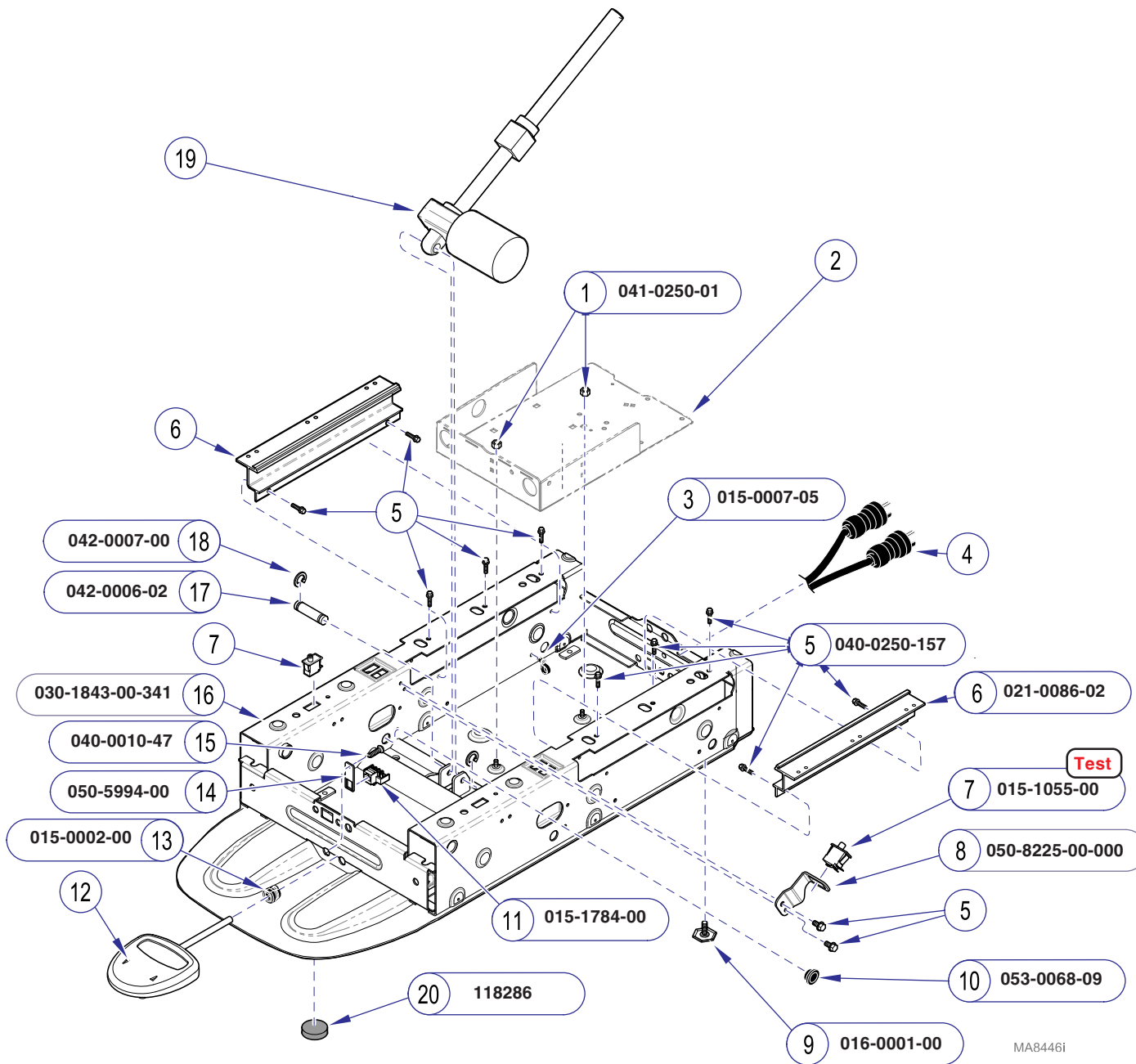

Refer To:	Page
Limit Switch Test	B-5
Section D - Wiring Diagrams	D-1
Foot Control:	
222 / 622	E-26
223	E-27.1
Base Actuator	E-21
PC Board Enclosure:	
Manual Back models	E-22
Power Back models	E-23
PowerCords	E-38

Item	Description	Qty.
1	Nut	2
2	Refer to: "PC board Enclosure"	Ref
3	Wrap-N-Tap Wire Clamp	3
4	Refer to: "Power Cords"	1
5	Screw	12
6	Slide Extrusion	2
7	Limit Switch	2
8	Limit Switch Bracket	1
9	Leveling Screw	2
10	Snap Bushing	1
11	Modular Plug (223 Only)	1
12	Refer to: "Foot Control"	Ref
13	Strain Relief Bushing (222 only)	1
14	Modular Plug Adapter Plate (223 only)	1
15	Screw (223 only)	1
16	Base Weldment	1
17	Clevis Pin	1
18	E-Ring	2
19	Refer to: "Base Actuator"	Ref
20	Non-Skid Pad	2

Always Specify Model & Serial Number

Models:	222 (-016)	223 (-016)
	Serial Numbers: V1182654 thru Present	Serial Numbers: V1182654 thru Present

**Ritter Base
Components**

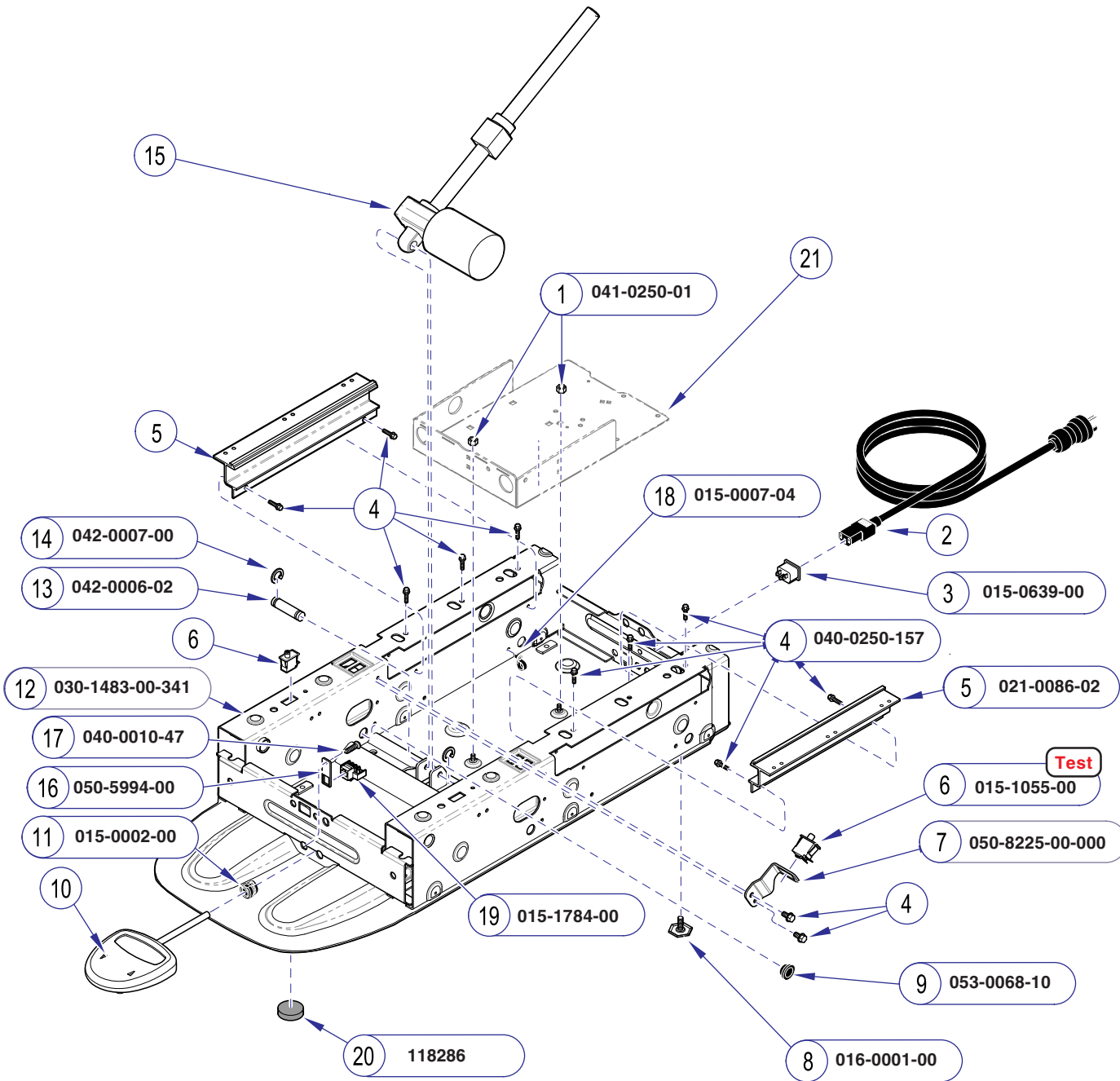

MA8445i

Refer To:	Page
Limit Switch Test	B-5
Section D - Wiring Diagrams	D-1
Foot Control:	
222 / 622	E-26
223	E-27.1
Base Actuator	E-21
PC Board Enclosure:	
Manual Back models	E-22
Power Back models	E-23
Power Cords	E-38

Item	Description	Qty.
1	Nut	2
2	Refer to: "PC board Enclosure"	Ref
3	Wrap-N-Tap Wire Clamp	3
4	Refer to: "Power Cords"	1
5	Screw	12
6	Slide Extrusion	2
7	Limit Switch	2
8	Limit Switch Bracket	1
9	Leveling Screw	2
10	Snap Bushing	1
11	Modular Plug (223 Only)	1
12	Refer to: "Foot Control"	Ref
13	Strain Relief Bushing (222 only)	1
14	Modular Plug Adapter Plate (223 only)	1
15	Screw (223 only)	1
16	Base Weldment	1
17	Clevis Pin	1
18	E-Ring	2
19	Refer to: "Base Actuator"	Ref
20	Non-Skid Pad	2

Always Specify Model & Serial Number

This page intentionally left blank.

Midmark Base Components

© Midmark Corporation 2005 SF-1822 Rev. 12/11

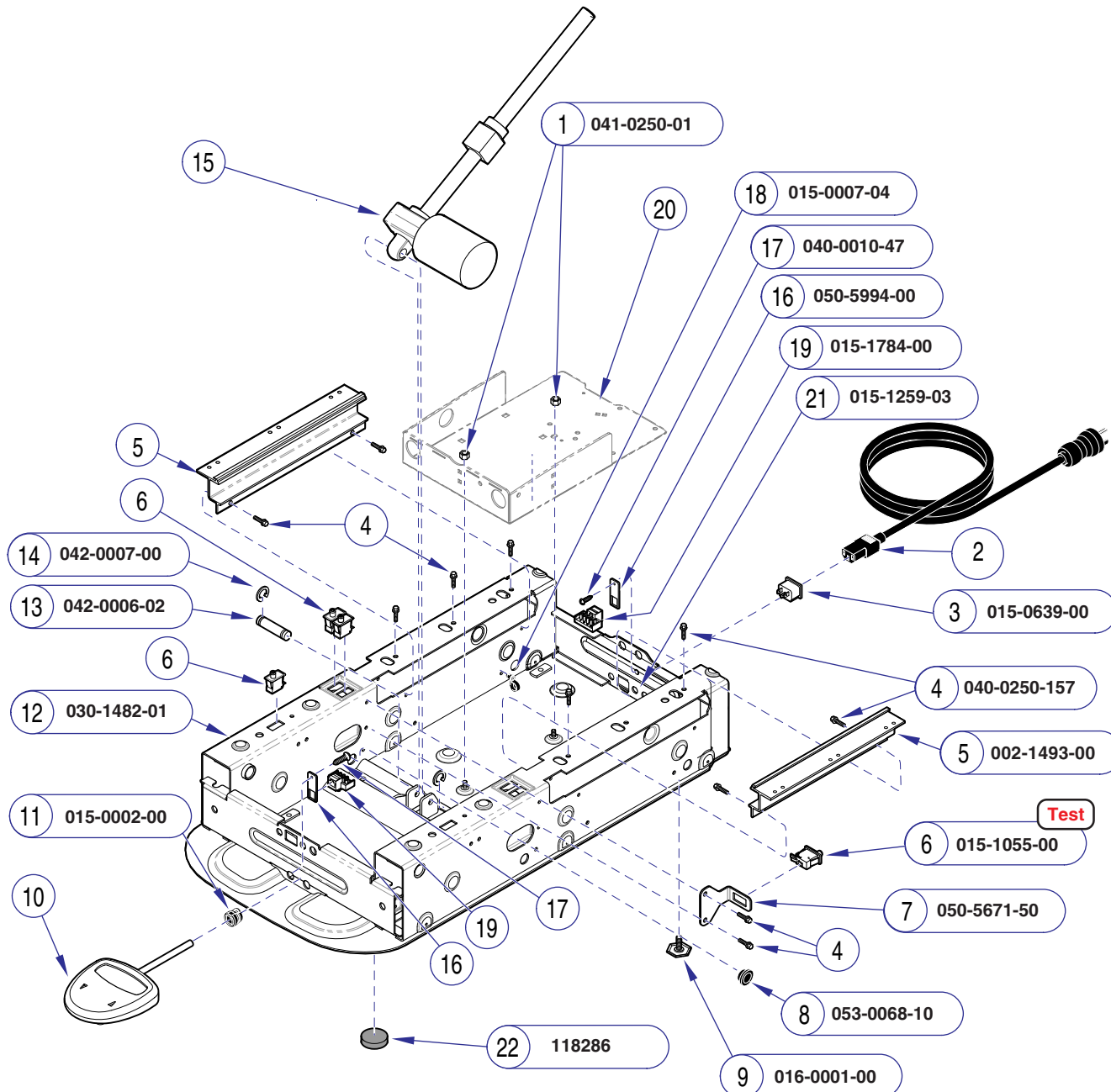

Refer To:	Page
Limit Switch Test	B-5
Foot Control:	
222 / 622	E-26
623	E-28*
Base Actuator	E-21
PC Board Enclosure:	
Manual Back models	E-22
Power Back models	E-23
Power Cords	E-38
* multiple pages due to model / serial # break	

Item	Description	Qty.
1	Nut	2
2	Refer to: "Power Cords"	1
3	IEC Inlet	1
4	Screw	12
5	Kit, Scissor Rollers	1
6	Limit Switch	4
7	Limit Switch Bracket	1
8	Snap Bushing	1
9	Leveling Screw	2
10	Refer to: "Foot Control"	Ref
11	Strain Relief Bushing (622 only)	1
12	Base Weldment	1
13	Clevis Pin	1
14	E-Ring	2
15	Refer to: "Base Actuator"	Ref
16	Modular Plug Adapter Plate (622)	1
17	Modular Plug Adapter Plate (623)	2
18	Screw (622)	1
19	Screw (623)	2
20	Refer to: "PC board Enclosure"	Ref
21	Fuseholder (622 & 623-003/-004)	2
22	Non-Skid Pad	2

Always Specify Model & Serial Number

MA623304i

Models:	622 (-001 thru -006)	623 (-001 thru -006)
Serial Numbers:	SJ1000 thru present V2200 thru V58433	SK1000 thru present SL1000 thru present V2200 thru V58433
		SM1000 thru present

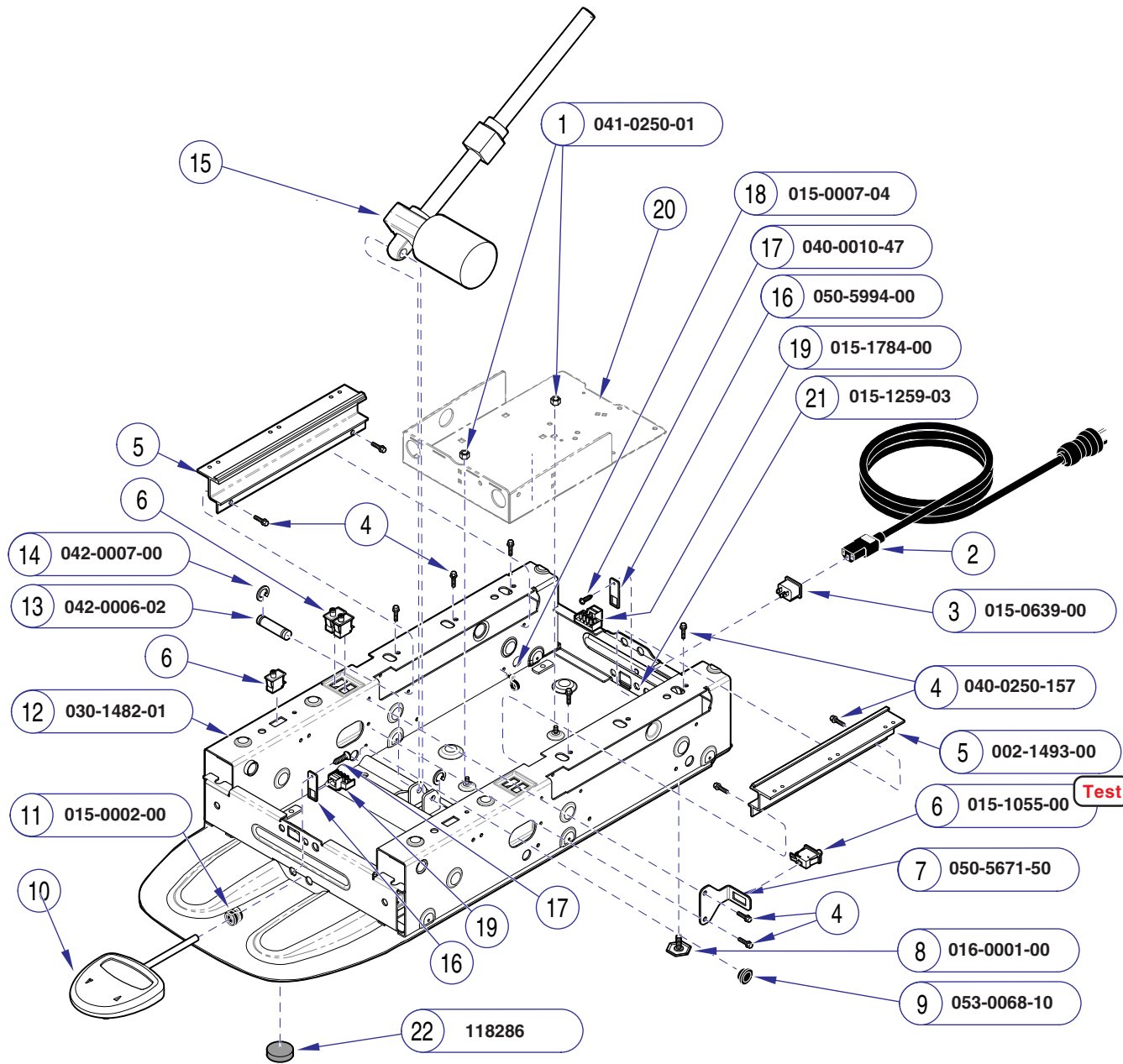

MA623305i

Refer To: **Page**

Limit Switch Test	B-5
Foot Control:	
222 / 622	E-26
623	E-28.1
Base Actuator	E-21
PC Board Enclosure:	
Manual Back models	E-22
Power Back models	E-23
Power Cords	E-38

Item	Description	Qty.
1	Nut	2
2	Refer to: "Power Cords"	1
3	IEC Inlet	1
4	Screw	12
5	Kit, Scissor Rollers	1
6	Limit Switch	4
7	Limit Switch Bracket	1
8	Leveling Screw	2
9	Snap Bushing	1
10	Refer to: "Foot Control"	Ref
11	Strain Relief Bushing (622 only)	1
12	Base Weldment	1
13	Clevis Pin	1
14	E-Ring	2
15	Refer to: "Base Actuator"	Ref
16	Modular Plug Adapter Plate (622)	1
	Modular Plug Adapter Plate (623)	2
17	Screw (622)	1
	Screw (623)	2
18	Wrap-N-Tap Wire Clamp	3
19	Modular Plug (622)	1
	Modular Plug (623)	2
20	Refer to: "PC board Enclosure"	Ref
21	Fuseholder (Export models only)	2
22	Non-Skid Pad	2

Always Specify Model & Serial Number

Models:	622 (-001 thru -006)	623 (-001 thru -006)	623 (-009 & -010)
Serial Numbers:	V58464 thru V1158421	V58464 thru V1158421	V58464 thru V1158421

**Midmark Base
Components**

E-20.1

Midmark Base Components

Models: 622 (-001 thru -006) | 623 (-001 thru -006) | 623 (-009 & -010)
Serial Numbers: V1158422 thru V1182653 | V1158422 thru V1182653 | V1158422 thru V1182653

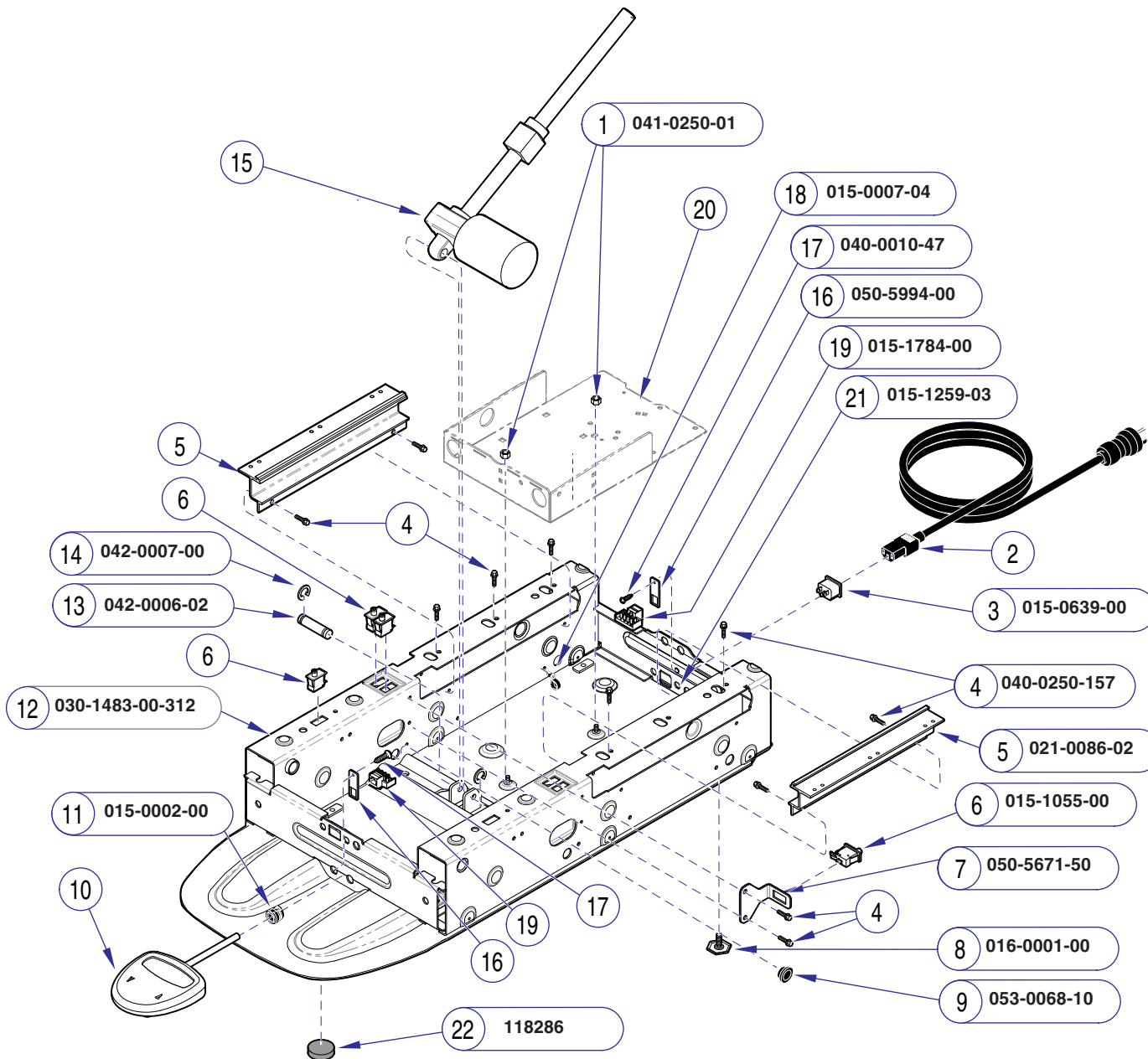

Refer To:	Page
Limit Switch Test	B-5
Foot Control:	
222 / 622	E-26
623	E-28.1
Base Actuator	E-21
PC Board Enclosure:	
Manual Back models	E-22
Power Back models	E-23
Power Cords	E-38

Item	Description	Qty.
1	Nut	2
2	Refer to: "Power Cords"	1
3	IEC Inlet	1
4	Screw	12
5	Slide Extrusion	2
6	Limit Switch	4
7	Limit Switch Bracket	1
8	Leveling Screw	2
9	Snap Bushing	1
10	Refer to: "Foot Control"	Ref
11	Strain Relief Bushing (622 only)	1
12	Base Weldment	1
13	Clevis Pin	1
14	E-Ring	2
15	Refer to: "Base Actuator"	Ref
16	Modular Plug Adapter Plate (622)	1
	Modular Plug Adapter Plate (623)	2
17	Screw (622)	1
	Screw (623)	2
18	Wrap-N-Tap Wire Clamp	3
19	Modular Plug (622)	1
	Modular Plug (623)	2
20	Refer to: "PC board Enclosure"	Ref
21	Fuseholder (Export models only)	2
22	Non-Skid Pad	2

Always Specify Model & Serial Number

This page intentionally left blank.

Midmark Base Components

Models: 622 (-007 & -008)
 Serial Numbers: V58464 thru V798445

623 (-007 & -008)
 V58464 thru V798445

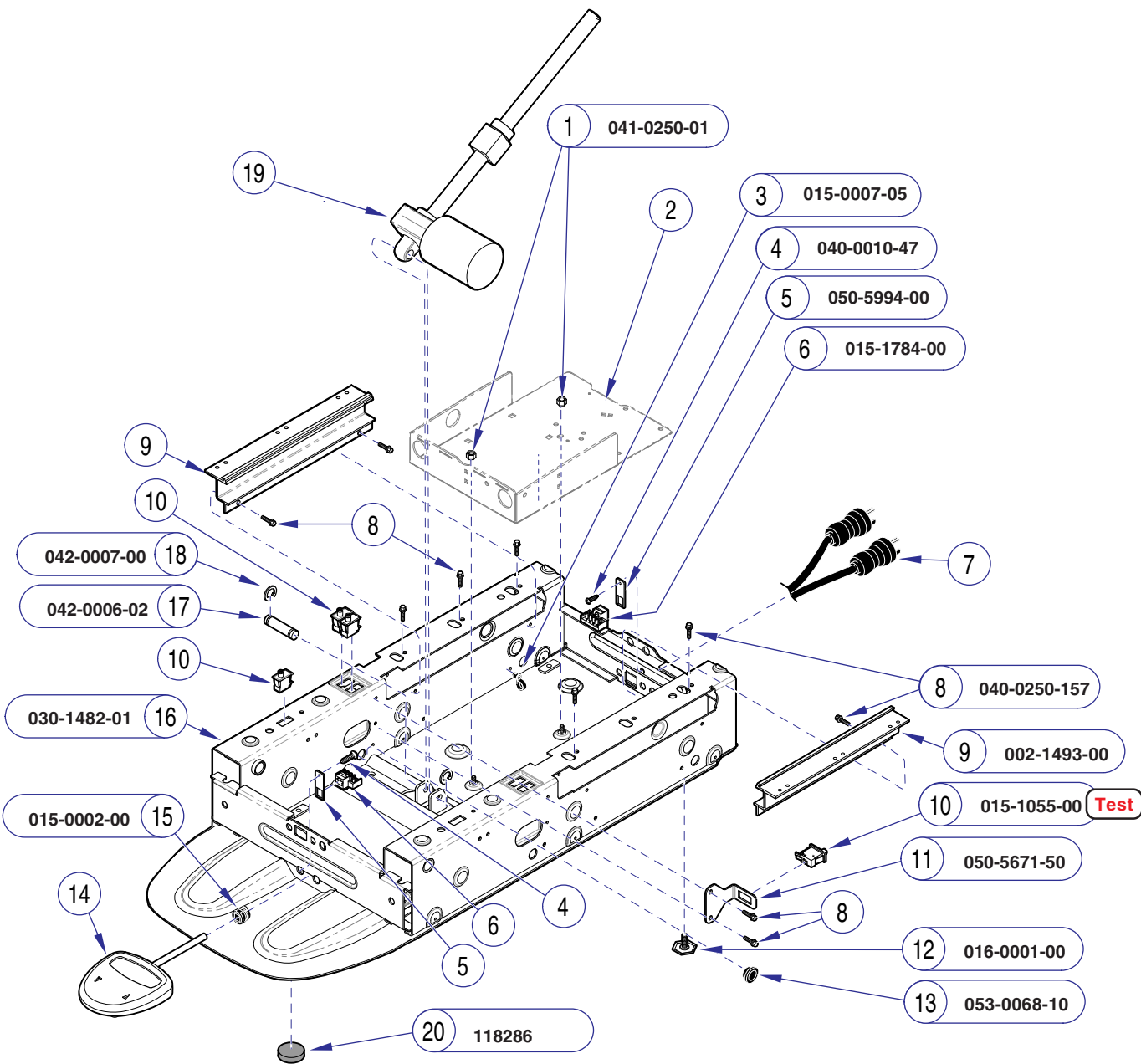

MA623306I

Refer To:	Page
Limit Switch Test	B-5
Section D - Wiring Diagrams	D-1
Foot Control:	
222 / 622	E-26
623	E-28.1
Base Actuator	E-21
PC Board Enclosure:	
Manual Back models	E-22
Power Back models	E-23
PowerCords	E-38

Item	Description	Qty.
1	Nut	2
2	Refer to: "PC board Enclosure"	Ref
3	Wrap-N-Tap Wire Clamp	3
4	Screw (623 only)	2
5	Modular Plug Adapter Plate (623 only)	2
6	Modular Plug (623 only)	2
7	Refer to: "Power Cords"	1
8	Screw	12
9	Kit, Scissor Rollers	1
10	Limit Switch (622)	2
	Limit Switch (623)	4
11	Limit Switch Bracket	1
12	Leveling Screw	2
13	Snap Bushing	1
14	Refer to: "Foot Control"	Ref
15	Strain Relief Bushing (622 only)	1
16	Base Weldment	1
17	Clevis Pin	1
18	E-Ring	2
19	Refer to: "Base Actuator"	Ref
20	Non-Skid Pad	2

Always Specify Model & Serial Number

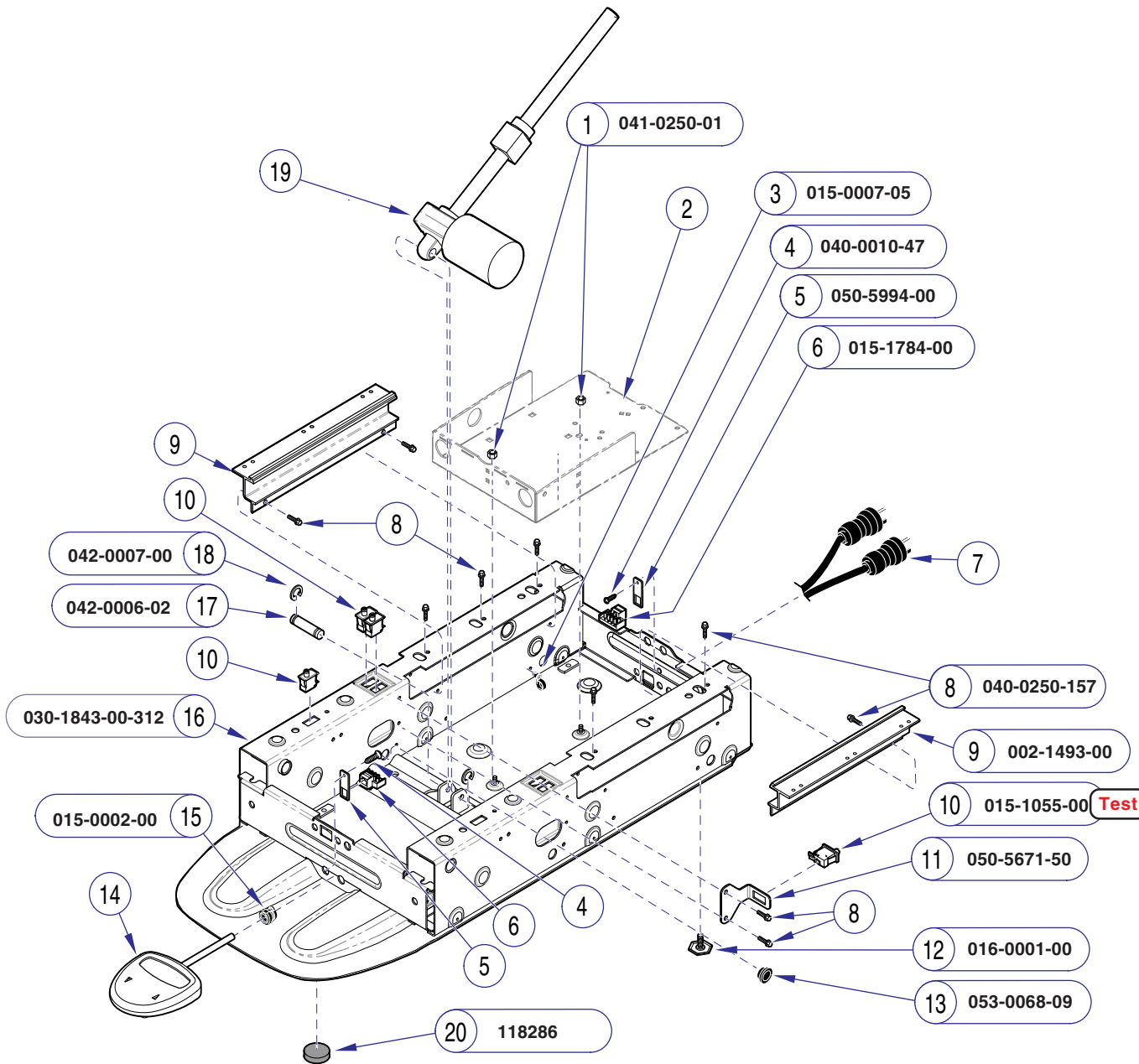

Refer To: **Page**

Limit Switch Test	B-5
Section D - Wiring Diagrams	D-1
Foot Control:	
222 / 622	E-26
623	E-28.1
Base Actuator	E-21
PC Board Enclosure:	
Manual Back models	E-22
Power Back models	E-23
PowerCords	E-38

Item	Description	Qty.
1	Nut	2
2	Refer to: "PC board Enclosure"	Ref
3	Wrap-N-Tap Wire Clamp	3
4	Screw (623 only)	2
5	Modular Plug Adapter Plate (623 only)	2
6	Modular Plug (623 only)	2
7	Refer to: "Power Cords"	1
8	Screw	12
9	Kit, Scissor Rollers	1
10	Limit Switch (622)	2
	Limit Switch (623)	4
11	Limit Switch Bracket	1
12	Leveling Screw	2
13	Snap Bushing	1
14	Refer to: "Foot Control"	Ref
15	Strain Relief Bushing (622 only)	1
16	Base Weldment	1
17	Clevis Pin	1
18	E-Ring	2
19	Refer to: "Base Actuator"	Ref
20	Non-Skid Pad	2

Always Specify Model & Serial Number

MA623306i

Models: **622 (-007 & -008)** **623 (-007 & -008)**
Serial Numbers: V798446 thru V1158421 V798446 thru V1158421

**Midmark Base
Components**

E-20.4

Refer To:	Page
Limit Switch Test	B-5
Section D - Wiring Diagrams	D-1
Foot Control:	
222 / 622	E-26
623	E-28.1
Base Actuator	E-21
PC Board Enclosure:	
Manual Back models	E-22
Power Back models	E-23
PowerCords	E-38

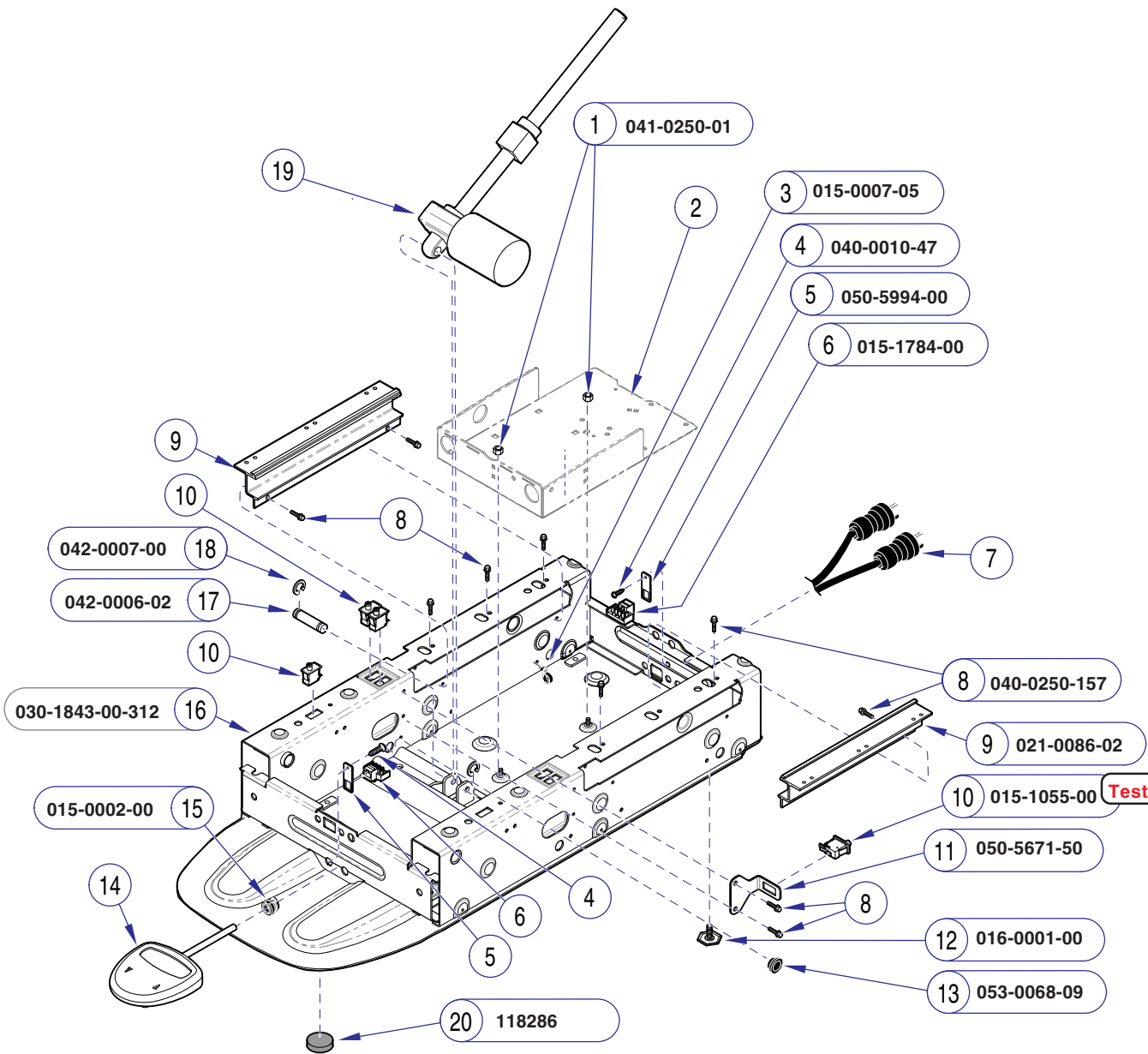

MA623306-1

Item	Description	Qty.
1	Nut	2
2	Refer to: "PC board Enclosure"	Ref
3	Wrap-N-Tap Wire Clamp	3
4	Screw (623 only)	2
5	Modular Plug Adapter Plate (623 only)	2
6	Modular Plug (623 only)	2
7	Refer to: "Power Cords"	1
8	Screw	12
9	Slide Extrusion	2
10	Limit Switch (622)	2
	Limit Switch (623)	4
11	Limit Switch Bracket	1
12	Leveling Screw	2
13	Snap Bushing	1
14	Refer to: "Foot Control"	Ref
15	Strain Relief Bushing (622 only)	1
16	Base Weldment	1
17	Clevis Pin	1
18	E-Ring	2
19	Refer to: "Base Actuator"	Ref
20	Non-Skid Pad	2

Always Specify Model & Serial Number

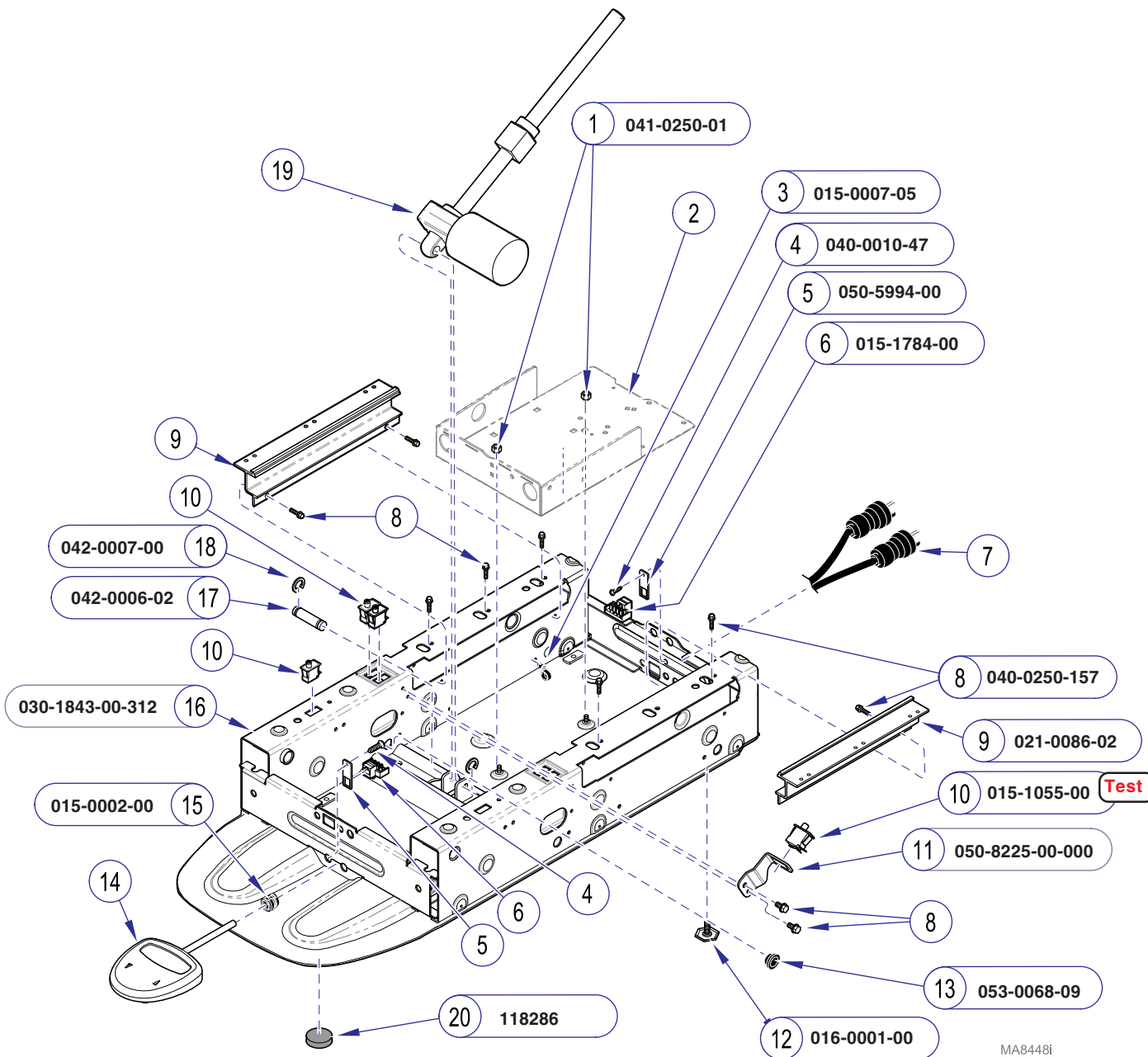

Refer To:	Page
Limit Switch Test	B-5
Section D - Wiring Diagrams	D-1
Foot Control:	
222 / 622	E-26
623	E-28.1
Base Actuator	E-21
PC Board Enclosure:	
Manual Back models	E-22
Power Back models	E-23
PowerCords	E-38

Item	Description	Qty.
1	Nut	2
2	Refer to: "PC board Enclosure"	Ref
3	Wrap-N-Tap Wire Clamp	3
4	Screw (623 only)	2
5	Modular Plug Adapter Plate (623 only)	2
6	Modular Plug (623 only)	2
7	Refer to: "Power Cords"	1
8	Screw	12
9	Slide Extrusion	2
10	Limit Switch (622)	2
	Limit Switch (623)	4
11	Limit Switch Bracket	1
12	Leveling Screw	2
13	Snap Bushing	1
14	Refer to: "Foot Control"	Ref
15	Strain Relief Bushing (622 only)	1
16	Base Weldment	1
17	Clevis Pin	1
18	E-Ring	2
19	Refer to: "Base Actuator"	Ref
20	Non-Skid Pad	2

Always Specify Model & Serial Number

Models: 623 (-008)
Serial Numbers: V1182654 thru Present

Midmark Base Components

Refer To: **Page**

Limit Switch Test	B-5
Foot Control:	
222 / 622	E-26
623	E-28.1
Base Actuator	E-21
PC Board Enclosure:	
Manual Back models	E-22
Power Back models	E-23
PowerCords	E-38

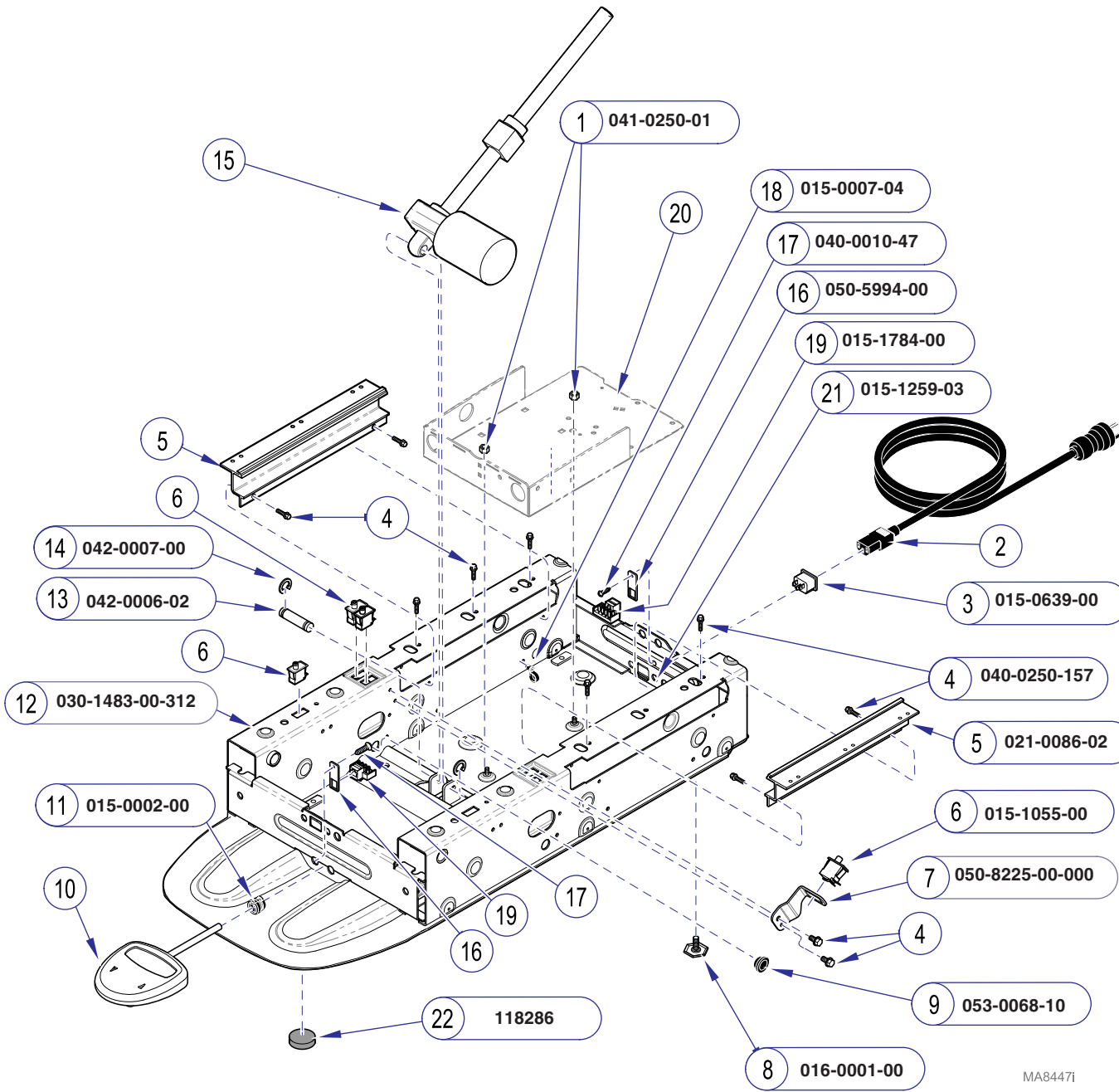

MA84471

Item	Description	Qty.
1	Nut	2
2	Refer to: "Power Cords"	1
3	IEC Inlet	1
4	Screw	12
5	Slide Extrusion	2
6	Limit Switch	4
7	Limit Switch Bracket	1
8	Leveling Screw	2
9	Snap Bushing	1
10	Refer to: "Foot Control"	Ref
11	Strain Relief Bushing (622 only)	1
12	Base Weldment	1
13	Clevis Pin	1
14	E-Ring	2
15	Refer to: "Base Actuator"	Ref
16	Modular Plug Adapter Plate (622)	1
16	Modular Plug Adapter Plate (623)	2
17	Screw (622)	1
17	Screw (623)	2
18	Wrap-N-Tap Wire Clamp	3
19	Modular Plug (622)	1
19	Modular Plug (623)	2
20	Refer to: "PC board Enclosure"	Ref
21	Fuseholder (Export models only)	2
22	Non-Skid Pad	2

Always Specify Model & Serial Number

Midmark Base Components

Models: 623 (-009 & -010)
Serial Numbers: V1182654 thru Present

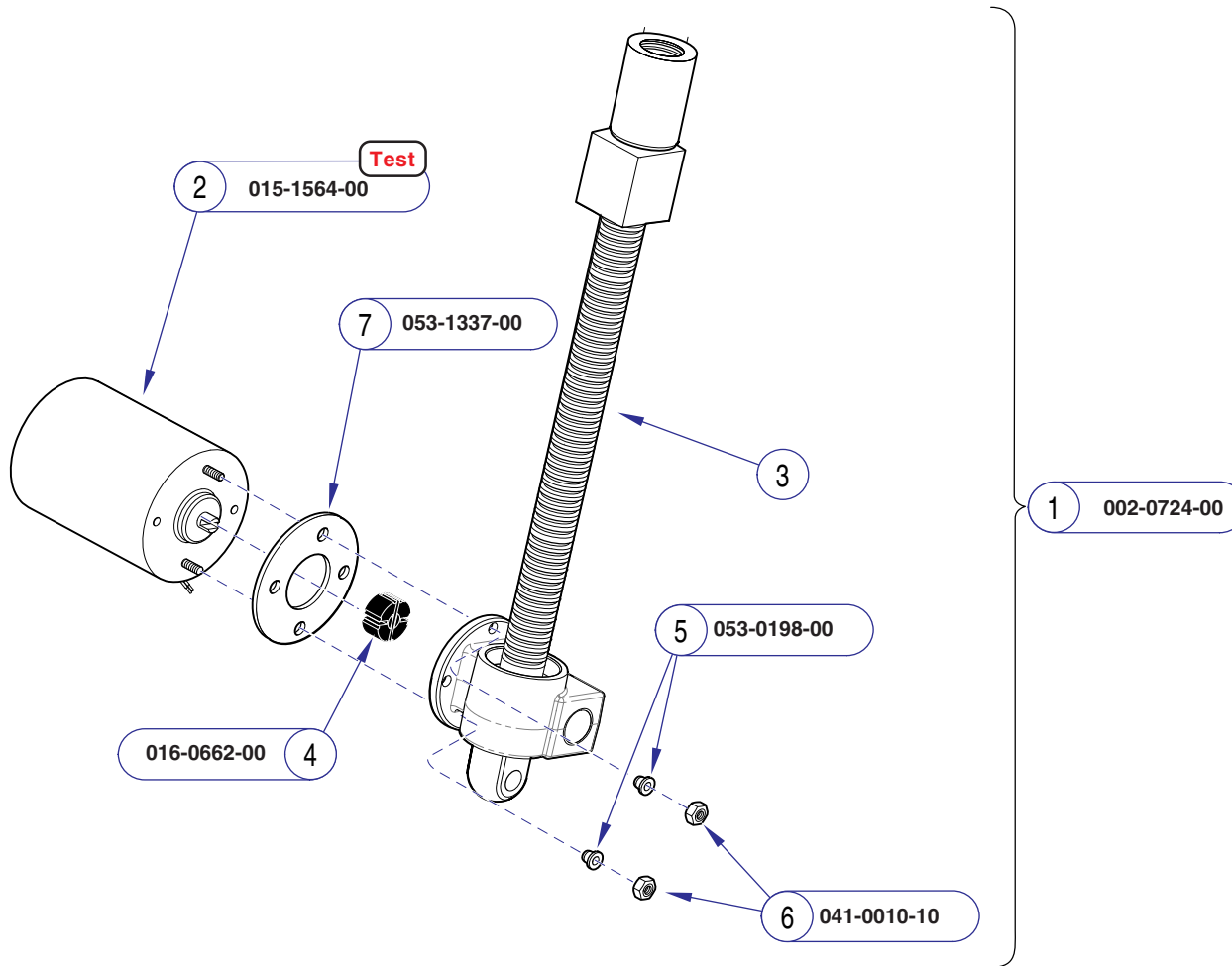

Item	Description	Qty.
1	Actuator Assembly Kit (includes items 2 thru 6)	1
2	• Motor	1
3	• Ball Screw Asm. (not available separately)1	1
4	• Coupler	1
5	• Shoulder Washer	2
6	• Nut	2
7	• Isolator	1

Always Specify Model & Serial Number

MA610900i

Models: All
Serial Numbers: All

Base Actuator

Refer To:	Page
Fuse Test	B-3
Main PC Board Test	B-19
Section D - Wiring Diagrams	D-1

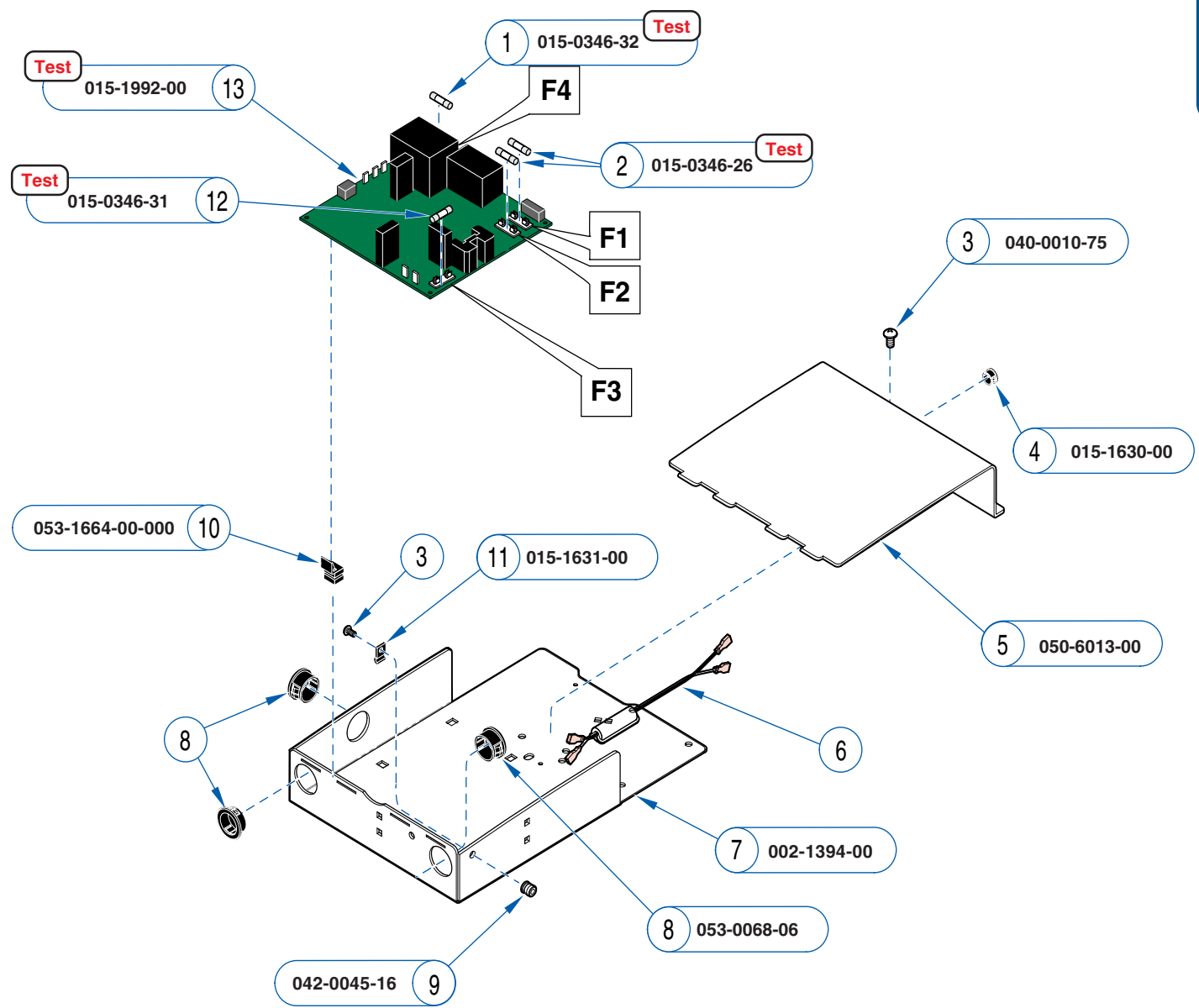

Item	Description	Qty.
1	Slo-blo Fuse (.18 A, 250v, .25" x 1.25")	1
2	Slo-blo Fuse (10 amp, 250v, .25" x 1.25")	2
3	Screw (10-24 x 3/8")	2
4	Split Grommet (older models only)	1
5	Cover	1
6	Refer to: Section D - Wiring Diagrams ...	Ref
7	Control Panel Housing Kit	1
8	Bushing	3
9	Nutsert	2
10	PC Board Standoff	7
11	Cable Clamp	1
12	Slo-blo Fuse (5 amp, 250v, .25" x 1.25") ..	1
13	PC Board (1 function)	1

Always Specify Model & Serial Number

MA637502i

PC Board Enclosure
(Manual Back Models)

Models:	222 (all)	622 (all)
Serial Numbers:	All	All

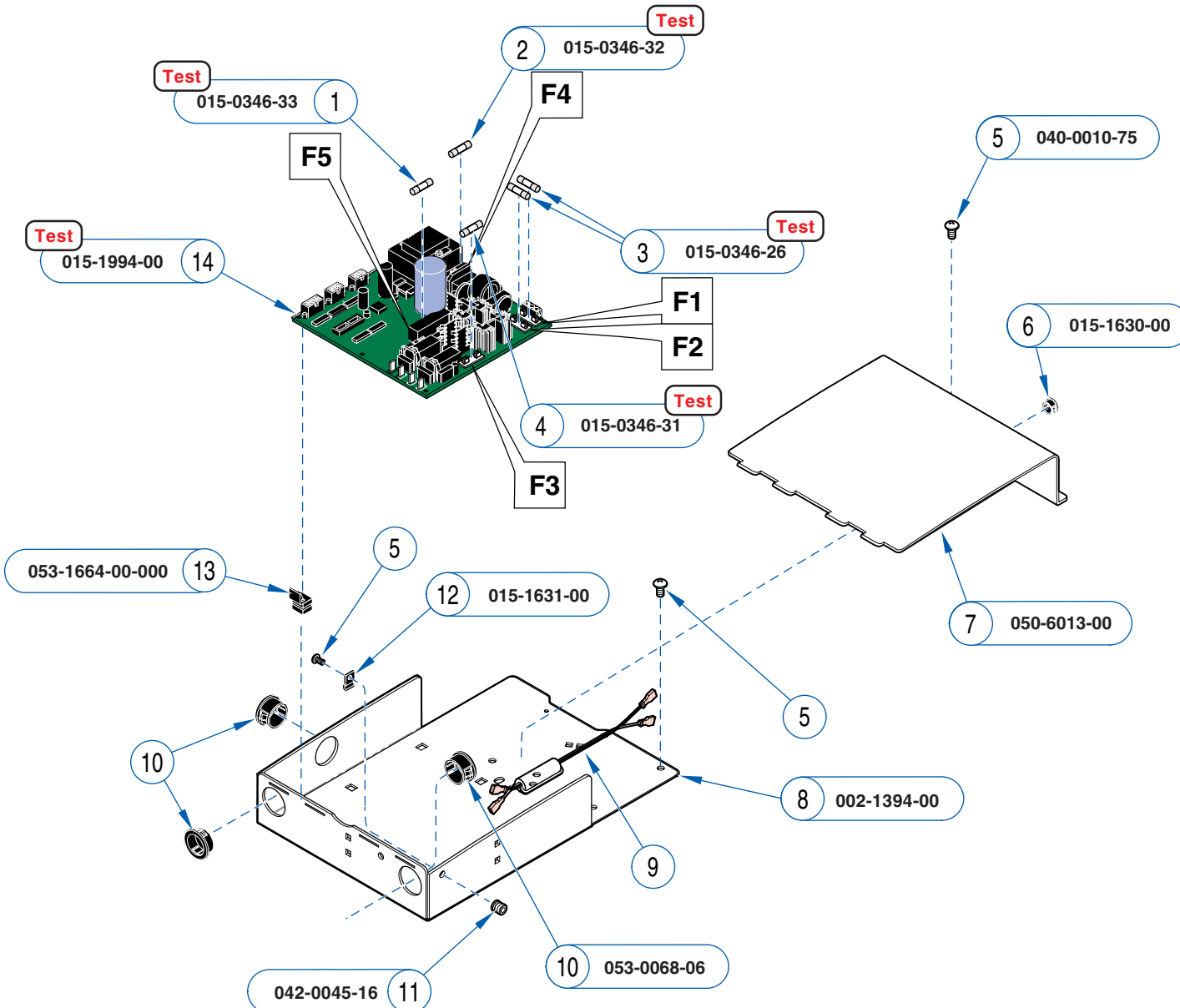

Item	Description	Qty.
1	Slo-blo Fuse (4 amp, 250v, .25" x 1.25") ..	1
2	Slo-blo Fuse (.18 amp, 250v, .25" x 1.25")	1
3	Slo-blo Fuse (10 amp, 250v, .25" x 1.25")	2
4	Slo-blo Fuse (5 amp, 250v, .25" x 1.25") ..	1
5	Screw (10-24 x .37")	5
6	Split Grommet (older models only)	1
7	Cover (item 6 - not required)	1
8	Control Panel Housing Kit	1
9	Refer to: Section D - Wiring Diagrams ...	Ref
10	Bushing	3
11	Nutsert	2
12	Cable Clamp	1
13	PC Board Standoff	7
14	PC Board (2 function)	1

Always Specify Model & Serial Number

MA637601i

Models: | **223 (all)** | **623 (all)**
 Serial Numbers: | All | All

PC Board Enclosure
 (Power Back Models)

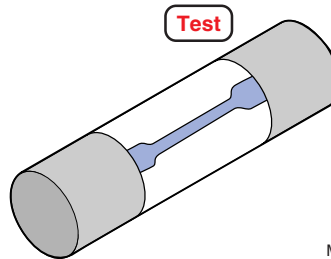

MA637700i

Fuse:	Location: (See next page)	Functions affected:	Rating:	Midmark Part Number:
Primary Fuses (2)	Main PC Board [F1 & F2]	All	10A, 250V, Slo-Blo, 1/4 x 1-1/4 in.	015-0346-26
Base Motor Fuse	Main PC Board [F3]	Base Up / Base Down	5A, 250V, Slo-Blo, 1/4 x 1-1/4 in.	015-0346-31
Transformer Fuse	Main PC Board [F4]	All	187mA, 250V, Slo-Blo, 1/4 x 1-1/4 in.	015-0346-32
Back Motor Fuse <i>(223 / 623 only)</i>	Main PC Board [F5]	Back Up / Back Down	4A, 250V, Slo-Blo, 1/4 x 1-1/4 in.	015-0346-33
Drawer Heater Fuses (2) <i>(optional)</i>	Distribution Board	Drawer Heater	800mA, 250V, Slo-Blo, 5 x 20 mm	015-0346-25
Upholstery Heater Fuses (2) <i>(optional)</i>	Upholstery PC Board	Upholstery Heater	1/2 A, 250V, Slo-Blo, 1/4 x 1-1/4 in.	015-0346-05
230 Volt Transformer Fuses (2) <i>(230 VAC models only)</i>	IEC Inlet	All	4A, 250V, Slo-Blo, 5 x 20 mm Interrupt Rating 40A @ 250V	015-0346-01
Isolation Transformer Fuses (2) <i>(Canadian models only)</i>	IEC Inlet	All	6.3 A, 250V, Slo-Blo, 5 x 20 mm	015-0346-20

Always Specify Model & Serial Number

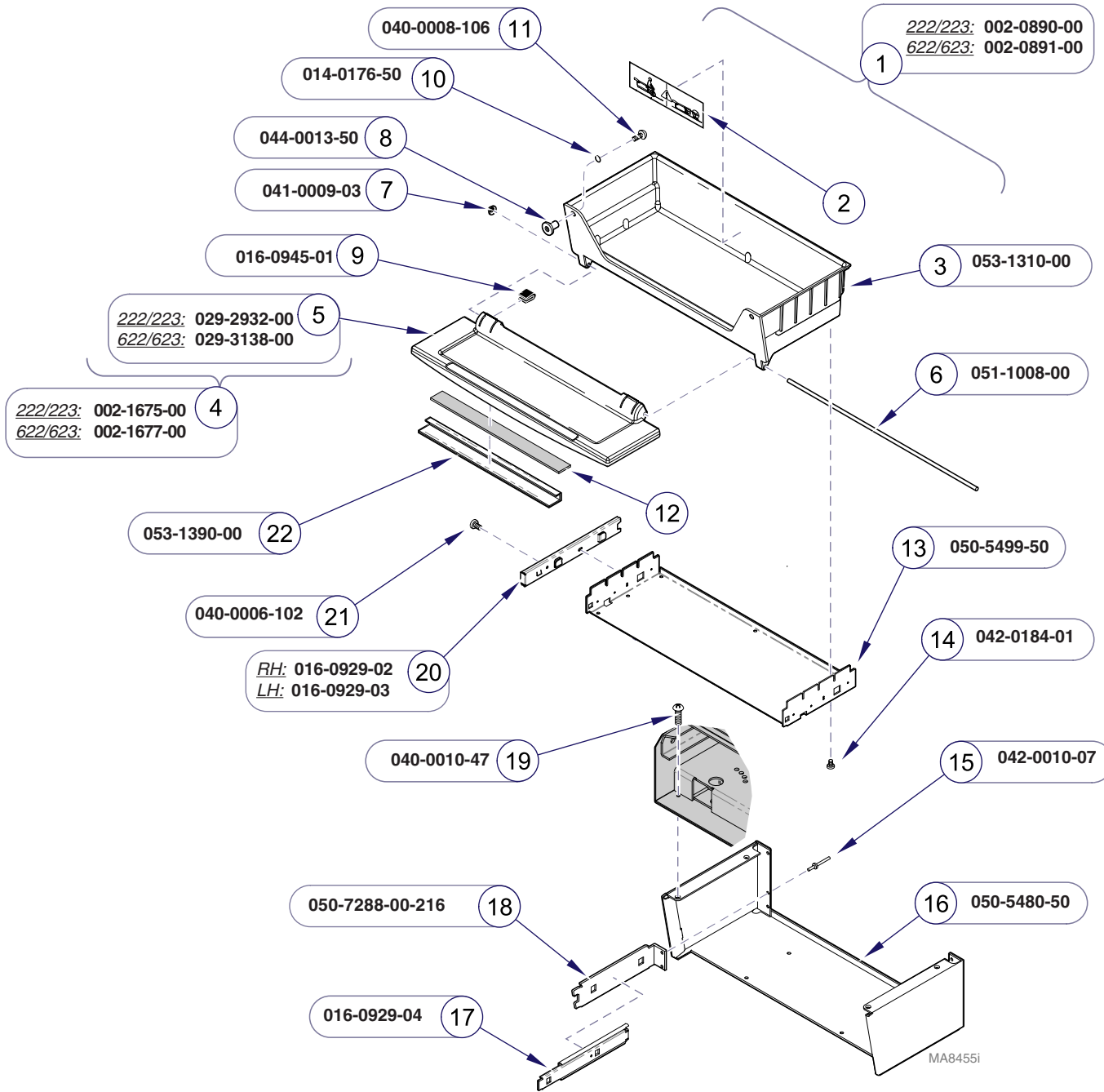

Refer To: **Page**

Upholstery - Midmark:

Premium E-8*

Ultra Premium E-9*

Label Location E-37

* multiple pages due to model / serial # break

Item	Description	Qty.
1	Exam Assistant® Drawer Assembly (includes items 2 thru 11)	1
2	• Refer to: "Label Location"	Ref
3	• Drawer	1
4	• Drawer Front & Hardware Kit (includes items 5 thru 7)	1
5	•• Drawer Front Assembly	1
6	•• Pivot Rod	1
7	•• Push Nut	2
8	• O-ring (early models only - not required)	2
9	• Edge Trim	2
10	• O-ring (early models only - not required)	2
11	• Screw (#8 x 32 x 1/4")	2
12	Color Insert - 622/623 only Refer to: Upholstery - Midmark	Ref
13	Drawer Heat Sink	1
14	Screw (M4-1.79 x 12mm)	5
15	Pop Rivet	4
16	Drawer Housing	1
17	Outer and Middle Slide Assy.	2
18	Drawer Slide Bracket	2
19	Screw	4
20	Inner Slide (RH shown)	2
21	Screw (#6-32 x 3/16" Phillips)	1
22	Clear Drawer Pull - 622/623 only	1

Always Specify Model & Serial Number

Models:	222 (all)	223 (all)	622 (all)	623 (all)
Serial Numbers:	V2200 thru V1308218	V2200 thru V1308233	V2200 Thru Present	V2200 thru V1321171

**Exam Assistant®
Drawer Assembly**

E-25

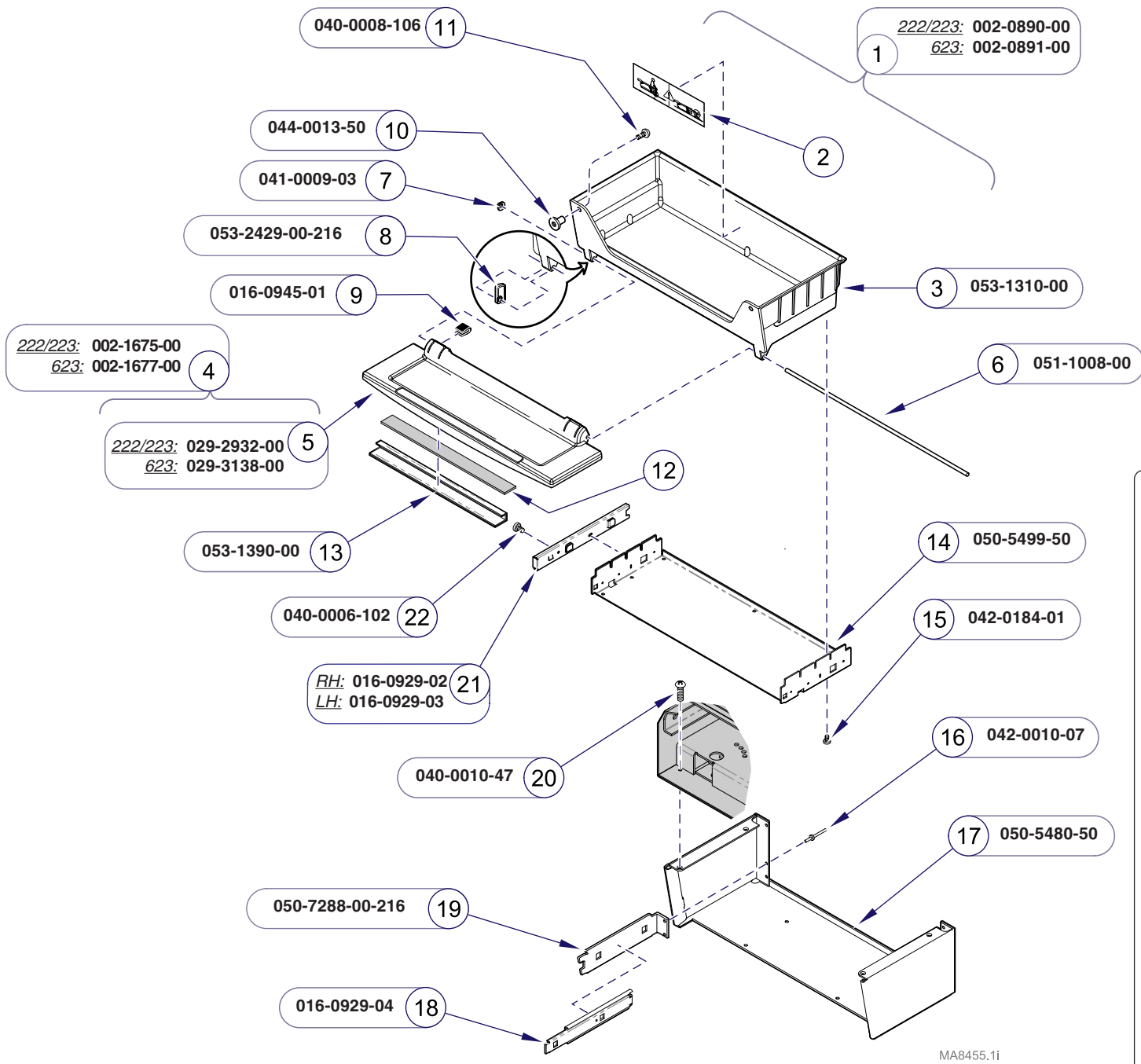

MA8455.1i

Item	Description	Qty.
1	Exam Assistant [®] Drawer Assembly (includes items 2 thru 11)	1
2	• Refer to: "Label Location"	Ref
3	• Drawer	1
4	• Drawer Front & Hardware Kit (includes items 5 thru 7)	1
5	•• Drawer Front Assembly	1
6	•• Pivot Rod	1
7	•• Push Nut	2
8	• Fold Down Drawer Stop	2
9	• Edge Trim	2
10	• Nut	2
11	• Screw (#8 x 32 x 1/4")	2
12	Color Insert - 622/623 only Refer to: Upholstery - Midmark	Ref
13	Clear Drawer Pull - 622/623 only	1
14	Drawer Heat Sink	1
15	Screw (M4-1.79 x 12mm)	5
16	Pop Rivet	4
17	Drawer Housing	1
18	Inner Slide (RH shown)	2
19	Drawer Slide Bracket	2
20	Screw	4
21	Outer and Middle Slide Assy.	2
22	Screw (#6-32 x 3/16" Phillips)	1

Always Specify Model & Serial Number

This page intentionally left blank.

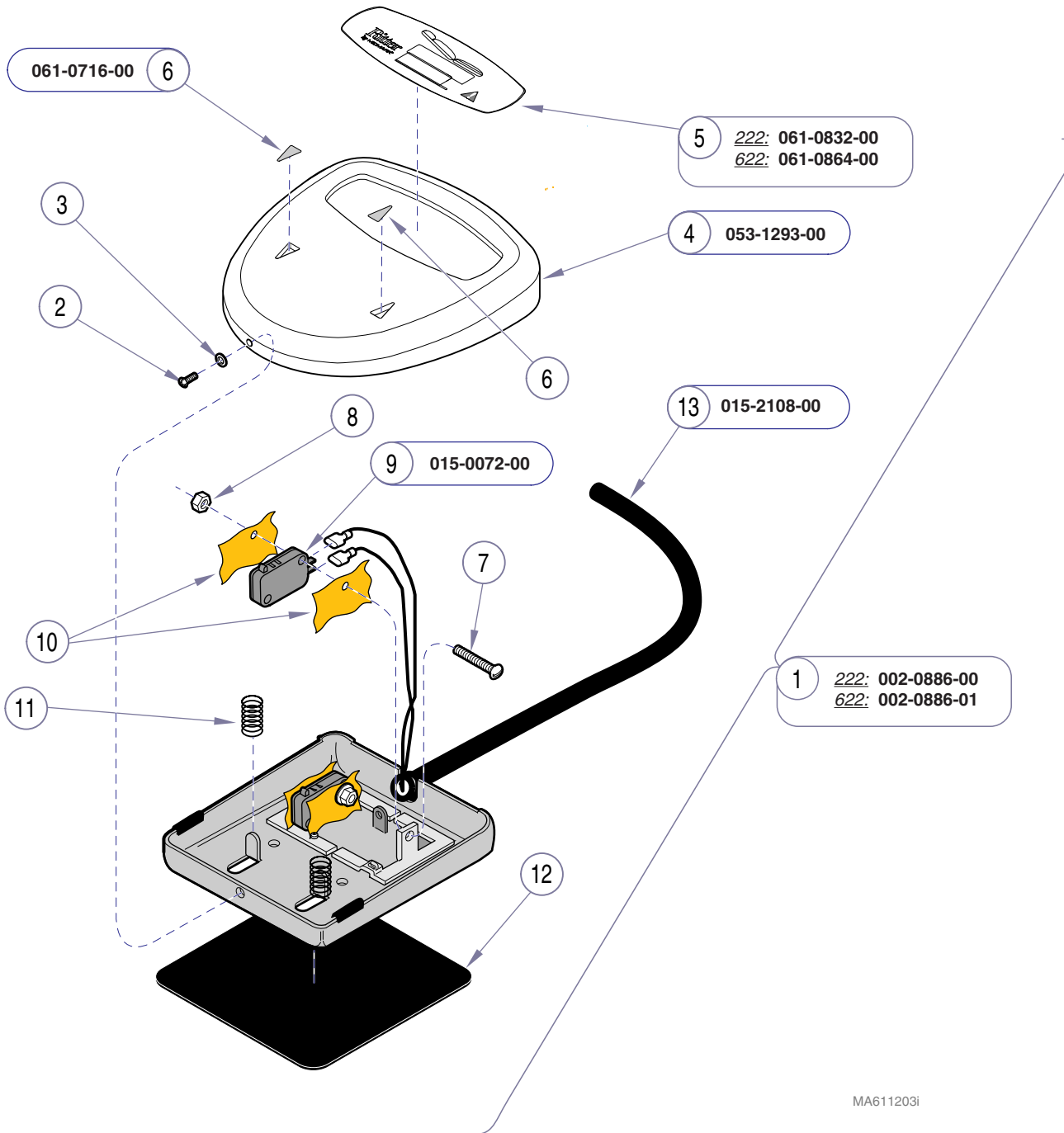

MA611203i

Item	Description	Qty.
1	Single Function Foot Control (incl. items 2 thru 13)	1
2	• Screw (not available)	1
3	• Washer (not available)	1
4	• Footswitch Cover	1
5	• Label	1
6	• Up / Down Arrow	2
7	• Screw (not available)	2
8	• Nut (not available)	2
9	• Foot Control Switch	2
10	• Insulator (not available)	2
11	• Spring (not available)	2
12	• Rubber Pad (not available)	1
13	• Cable	1

Always Specify Model & Serial Number

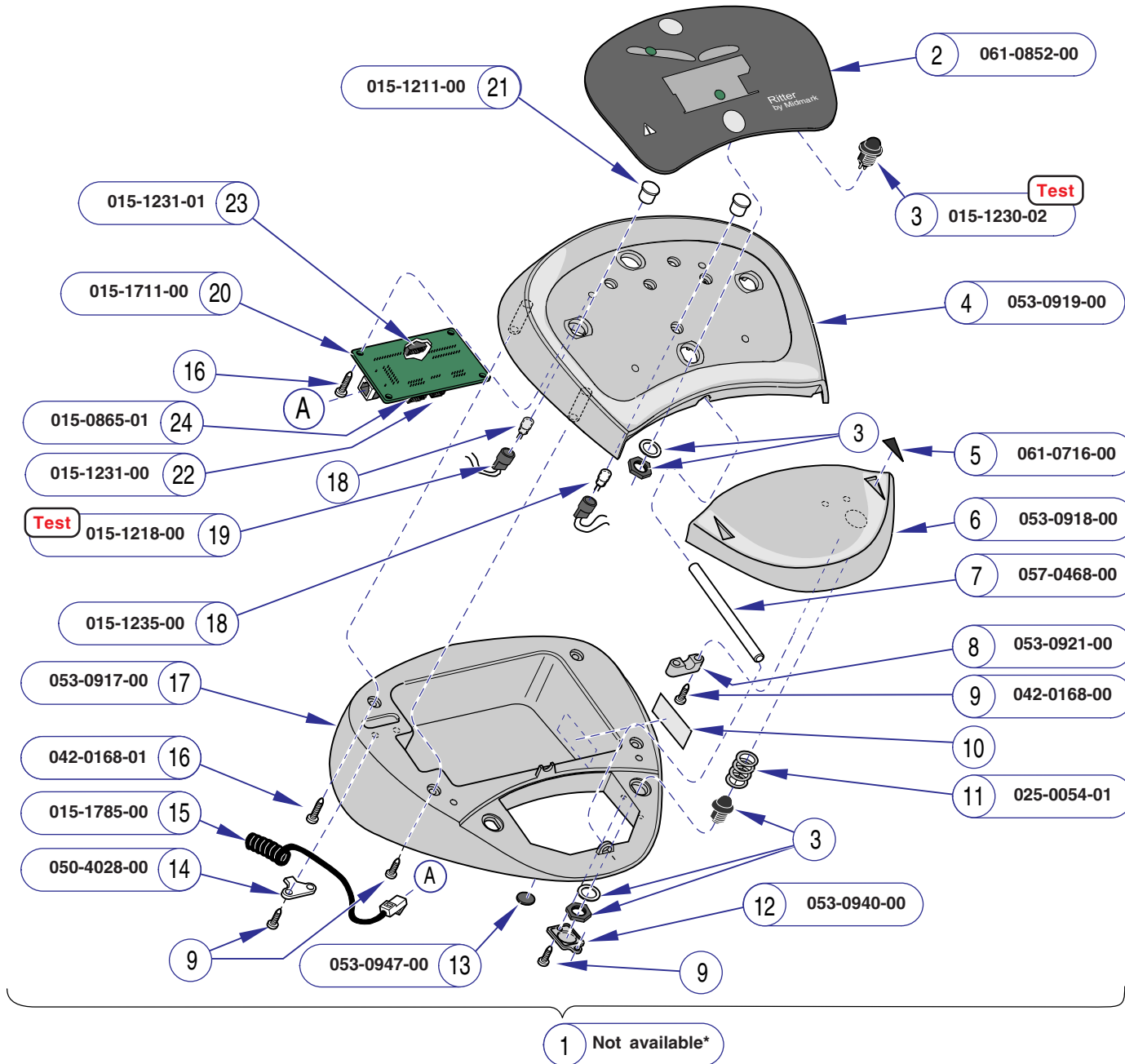

**This style foot control is no longer available. Subsequent version(s) are compatible. Refer to following page(s).*

Item	Description	Qty.
1	Two Function Foot Control	1
	(includes items 2 thru 24)	
2	• Footswitch Label	1
3	• Switch Assembly (7" leads)	4
4	• Foot Control Top	1
5	• Up/Down Labels	2
6	• Foot Control Pedal	1
7	• Pivot Shaft	1
8	• Pedal Cap	2
9	• Screw (metric K 3.5-1.57 x 10mm)	12
10	• Serial Number Label (not available)	1
11	• Spring	2
12	• Switch Cover	2
13	• Stem Bumper	8
14	• Strain Relief	1
15	• Retractable Cord	1
16	• Screw (metric K 3.5-1.57 x 16mm)	6
17	• Foot Control Base	1
18	• Green LED (w/ leads)	2
19	• Connector Assembly	2
20	• Two Function Control Board	1
21	• Clear Lens	2
22	• Modular Connector	1
23	• Receptacle Housing (4 position)	2
24	• Receptacle Housing (6 position)	2

Always Specify Model & Serial Number

Models: 223 (-001 thru -014)
Serial Numbers: SC1000 thru present SD1000 thru present
SE1000 thru present SF1000 thru present
V2200 thru V3302

Foot Control
(223)

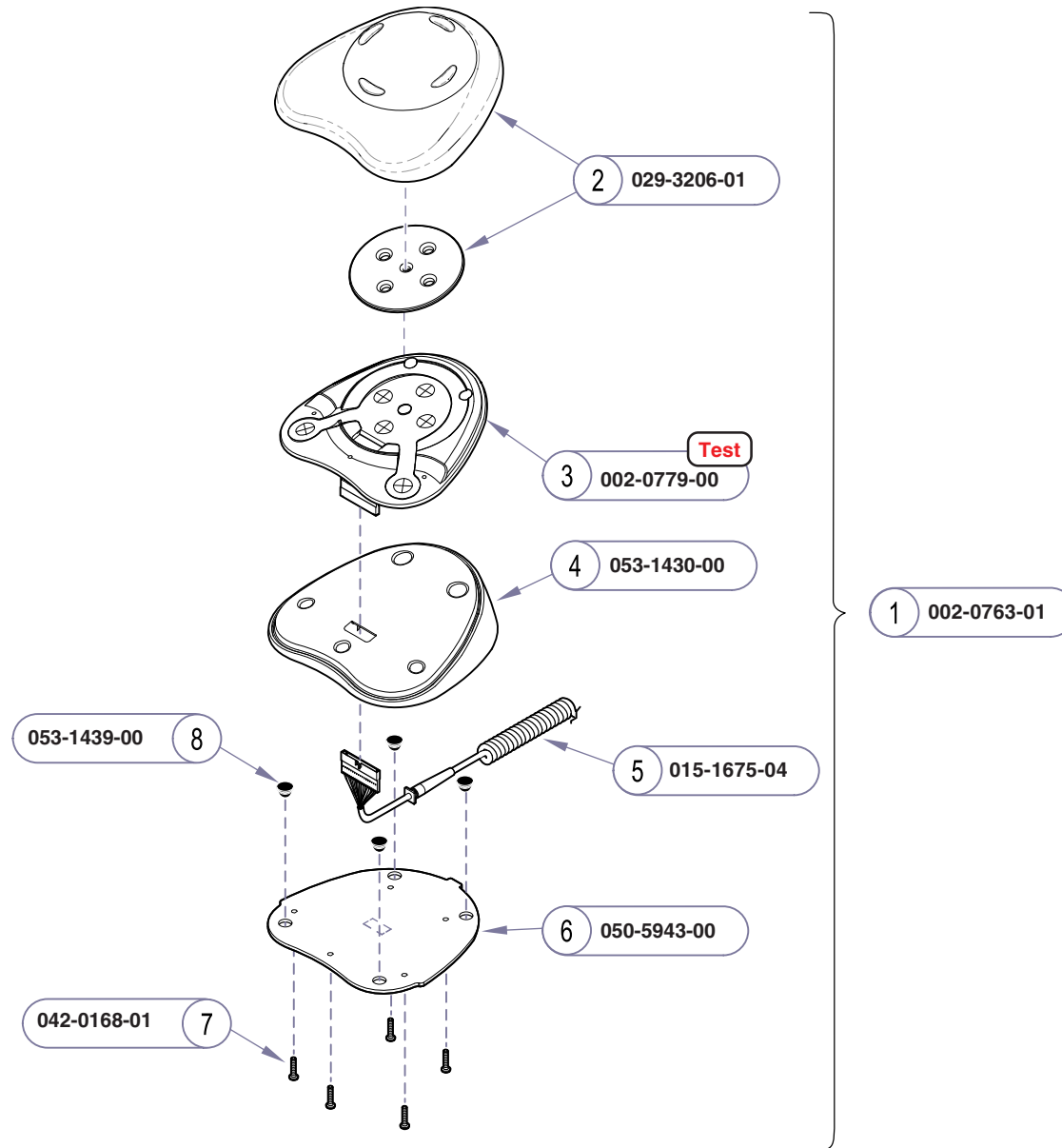

Item	Description	Qty.
1	Two Function Foot Control (incl. items 2 thru 8).....	1
2	• Keypad	1
3	• Switch Membrane Assembly	1
4	• Base	1
5	• Cord	1
6	• Base Plate	1
7	• Screw	5
8	• Stem Bumper	4

Always Specify Model & Serial Number

MA659300i

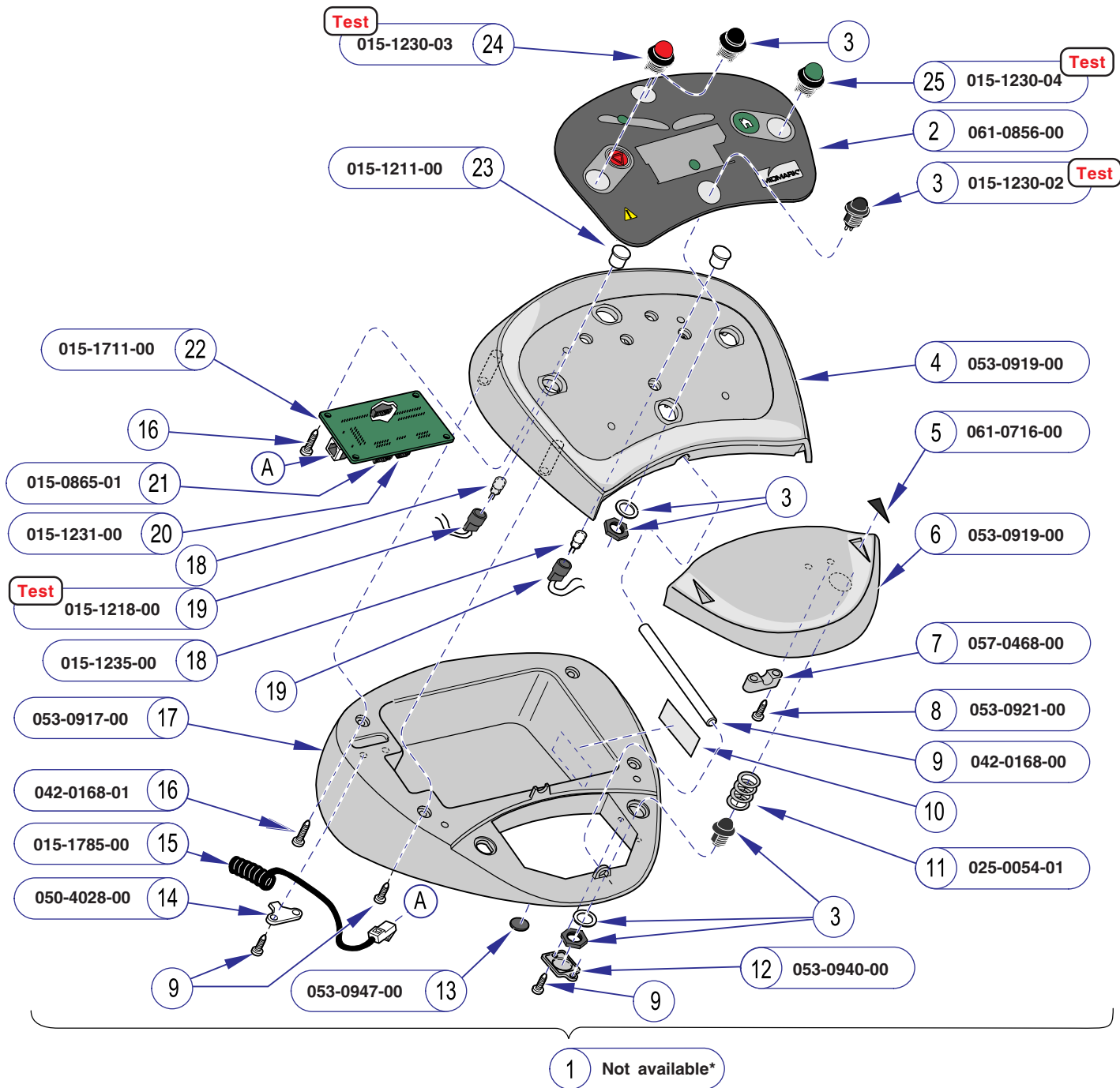

**This style foot control is no longer available. Subsequent version(s) are compatible. Refer to following page(s).*

Item	Description	Qty.
1	Two Function Foot Control	1
	<i>(includes items 2 thru 25)</i>	
2	• Footswitch Label	1
3	• Switch Assembly (7" leads)	4
	<i>(Black cap: 015-1205-03)</i>	
4	• Foot Control Top	1
5	• Up/Down Labels	2
6	• Foot Control Pedal	1
7	• Pivot Shaft	1
8	• Pedal Cap	2
9	• Screw (metric 3.5 x 10mm)	12
10	• Serial Number Label (not available)	1
11	• Spring	2
12	• Switch Cover	2
13	• Stem Bumper	8
14	• Strain Relief	1
15	• Retractable Cord	1
16	• Screw (metric 3.5 x 16mm)	6
17	• Foot Control Base	1
18	• Green LED (w/ leads)	2
19	• Connector Assembly	2
20	• Receptacle Housing (4 position)	2
21	• Receptacle Housing (6 position)	2
22	• Two Function Control Board	1
23	• Clear Lens	2
24	• Switch Assbly (5" leads)	1
	<i>(Red cap: 015-1205-04)</i>	
25	• Switch Assbly (5" leads)	1
	<i>(Green cap: 015-1205-05)</i>	

Always Specify Model & Serial Number

MA624100i

Models: 623 (-001 thru -006)
 Serial Numbers: SL1000 thru present SM1000 thru present
 V2200 thru V3302

Foot Control
 (623)

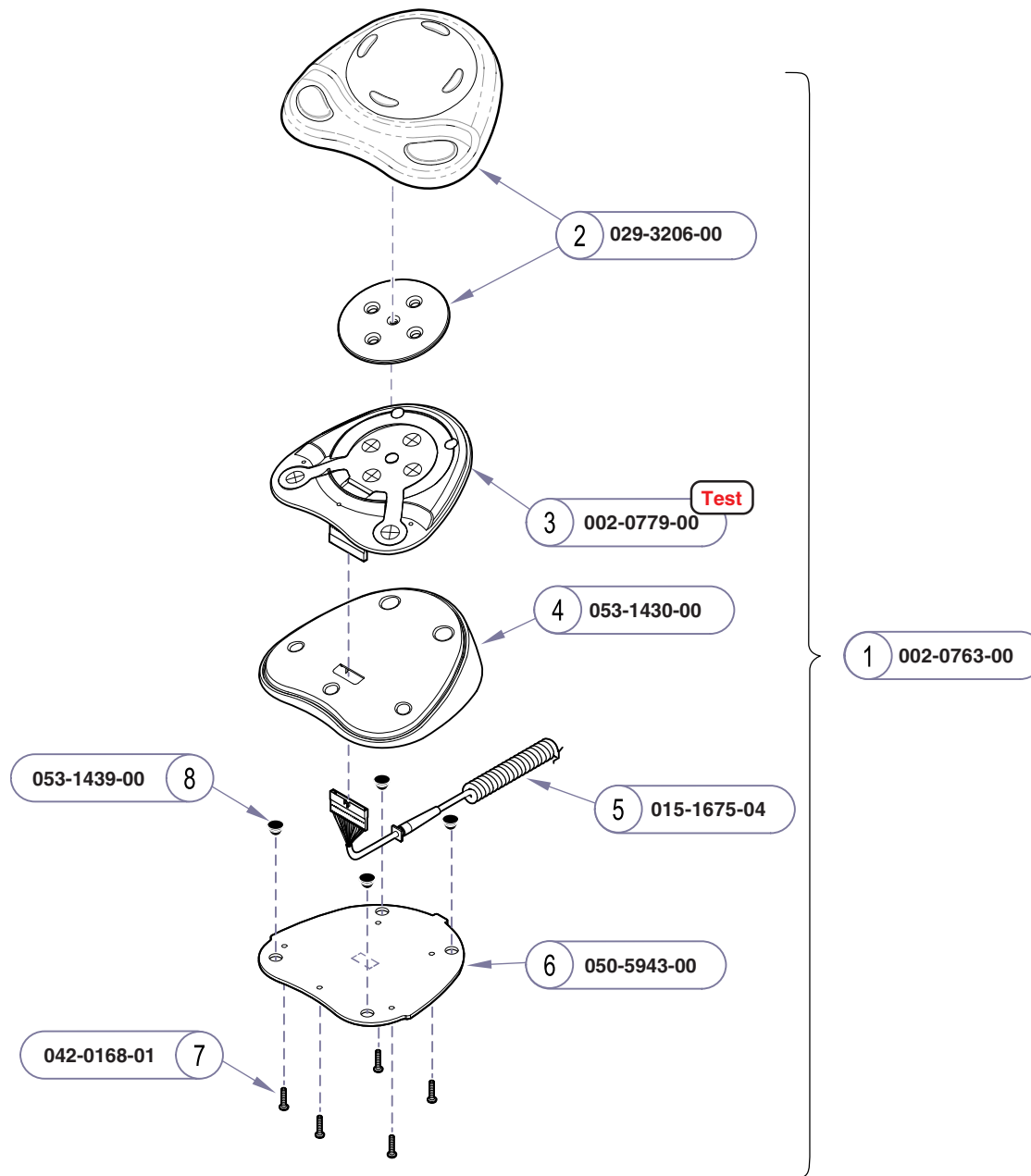

Item	Description	Qty.
1	Foot Control Assembly (incl. items 2 thru 8)	1
2	• Keypad	1
3	• Switch Membrane Assembly	1
4	• Base	1
5	• Cord	1
6	• Base Plate	1
7	• Screw	5
8	• Stem Bumper	4

Always Specify Model & Serial Number

MA676400i

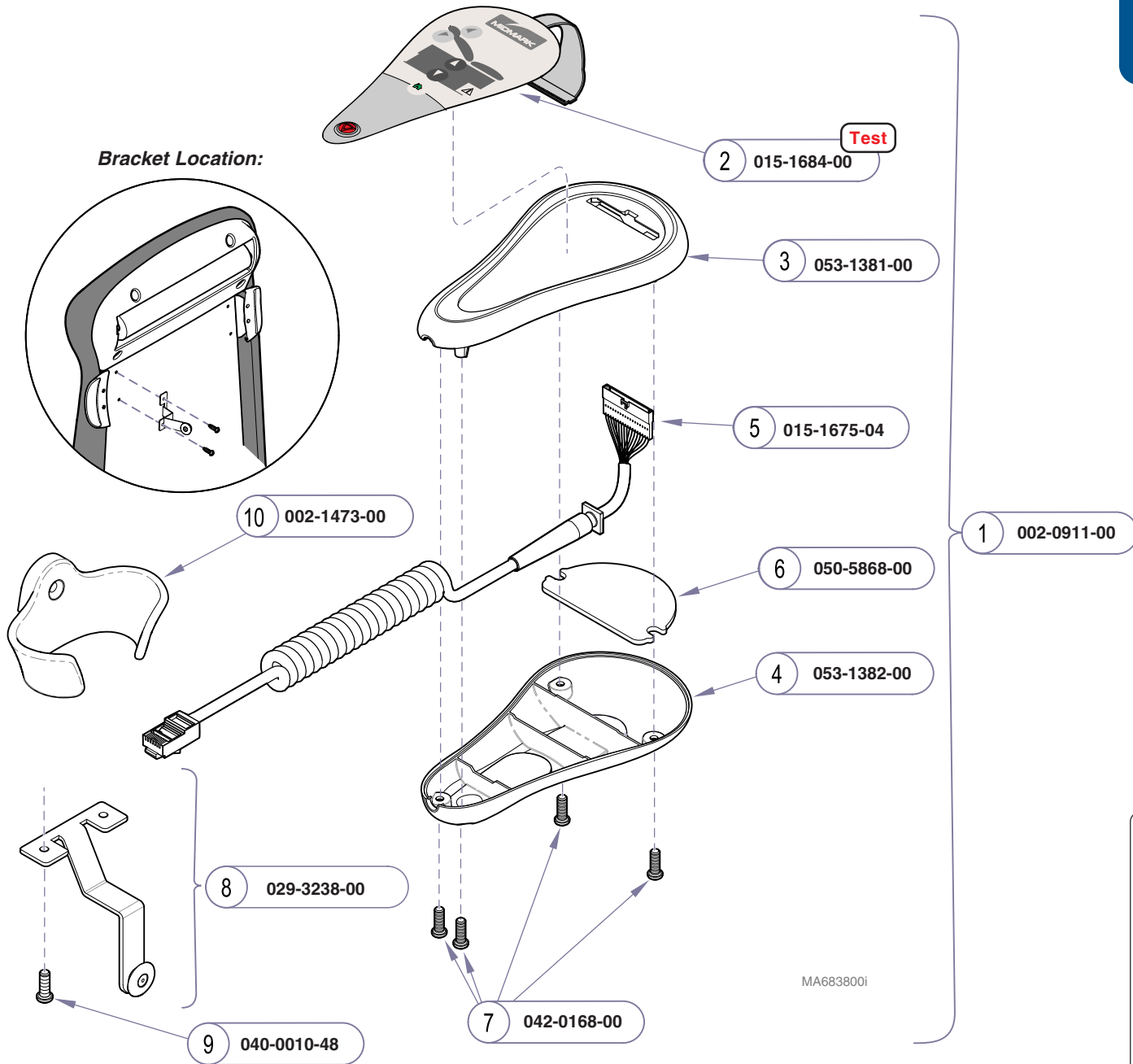

Item	Description	Qty.
1	Hand Control Assy. (incl. items 2 thru 8):	
2	• Touch Pad	
3	• Top Housing	1
4	• Bottom Housing	1
5	• Retractable Cord Assembly	1
6	• Hand Control Weight	1
7	• Screw (3.5 x 10)	4
8	• Mounting Bracket (incl. item 9)	1
9	• • Screw	2
10	• Hand Control Holster	1

Always Specify Model & Serial Number

Models: 623 (-001 thru -006) | 223 (-001 thru -014) [Optional]
 Serial Numbers: All | All

Hand Control & Mounting Bracket

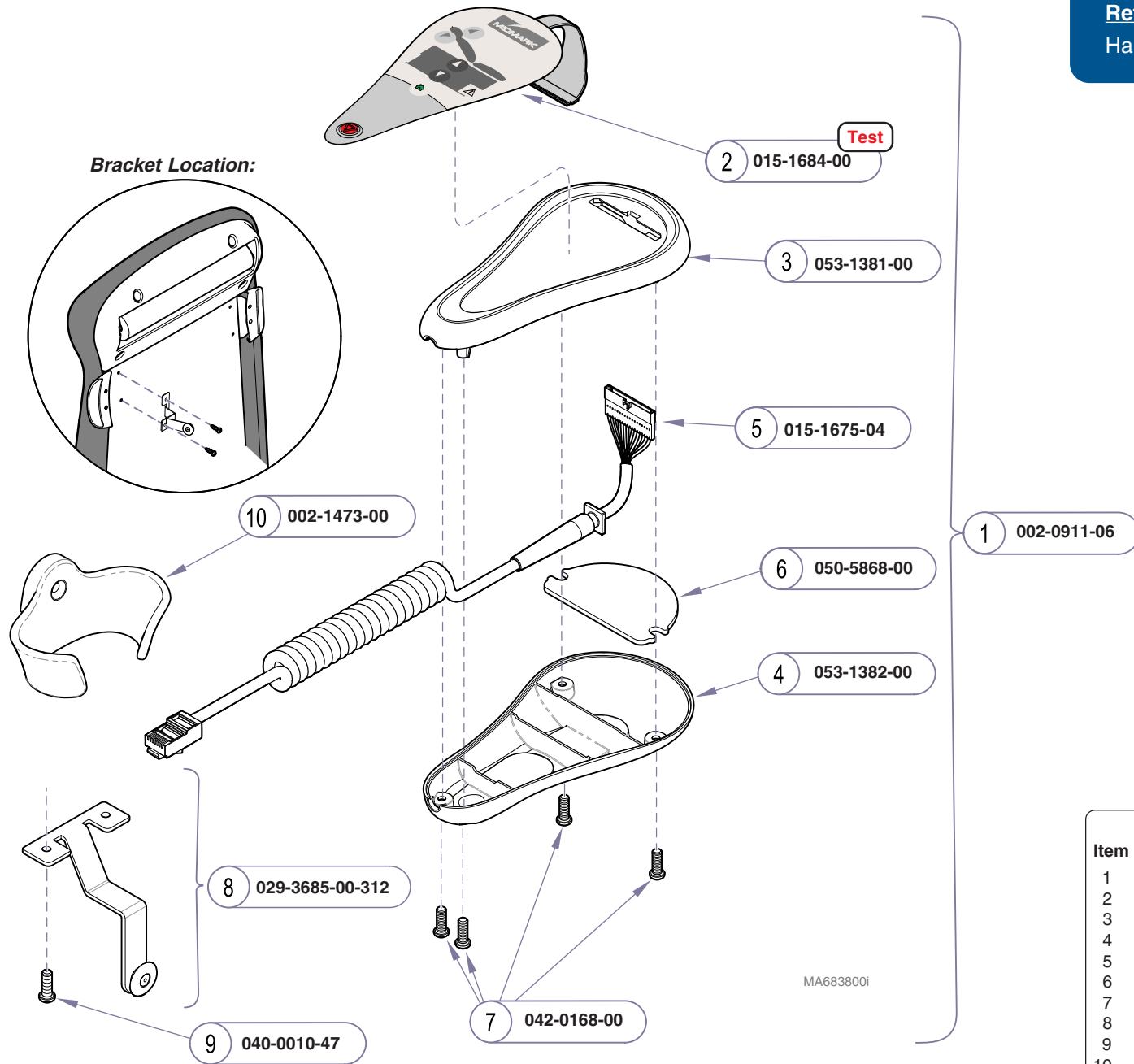

Item	Description	Qty.
1	Hand Control Assy. (incl. items 2 thru 10):	
2	• Touch Pad	
3	• Top Housing	1
4	• Bottom Housing	1
5	• Retractable Cord Assembly	1
6	• Hand Control Weight	1
7	• Screw (3.5 x 10)	4
8	• Mounting Bracket (incl. item 9)	1
9	• Screw	2
10	• Hand Control Holster	1

Always Specify Model & Serial Number

E-29.1

Hand Control & Mounting Bracket

Models: 623 (-007 thru -010) | 223 (-015 & -016) [Optional]
Serial Numbers: All | All

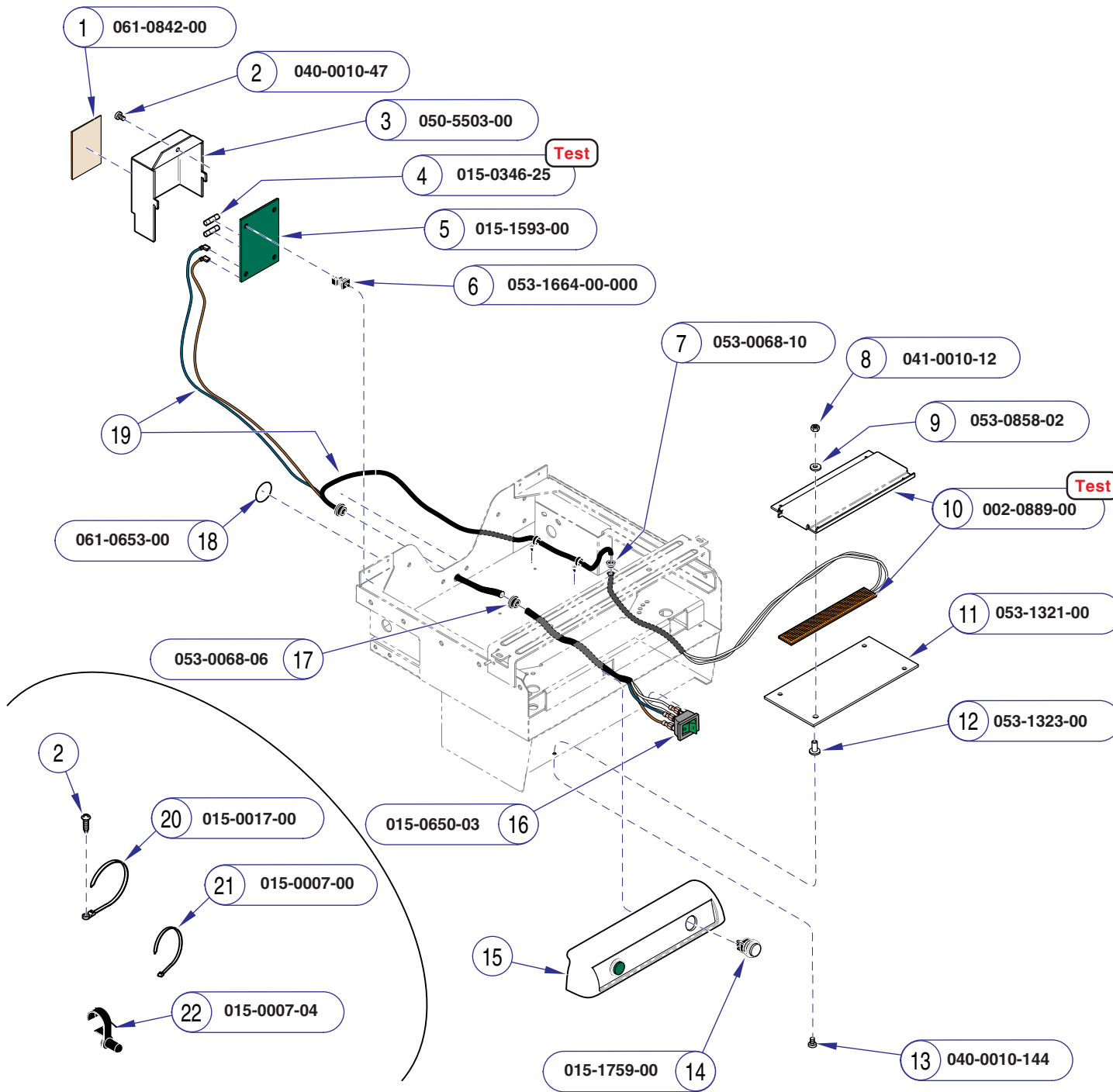

Refer To: **Page**
 Fuse **Test** B-3
 Drawer Heater System **Test** B-23
 Section D - Wiring Diagrams D-1
 Midmark Upperwrap
 & Footrest Shelf E-16

Item	Description	Qty.
1	Fuse Replacement Label	1
2	Screw (#10-24 x .37")	1
3	Distribution Board Cover	1
4	Fuse (800 mA, 250V, Slo-Blo, 5 x 20mm) ...	2
5	Distribution Board	1
6	PC Board Standoff	4
7	Snap Bushing	1
8	Nut (#10-32)	4
9	Nylon Washer	4
10	Heater Plate Assembly	1
11	Heater Insulation	1
12	Nylon Shoulder Washer	4
13	Screw (#10-32 x .5")	1
14	Drawer Htr. Switch / Harness (622/623)	1
15	Refer to: "Midmark Upperwrap & Footrest Shelf"	Ref
16	Drawer Heater Switch (222/223)	1
17	Snap Bushing	2
18	Ground Label	1
19	Refer to: Section D - Wiring Diagrams	Ref
20	Cable Tie (w/ screw hole)	2
21	Cable Tie	1
22	Wrap-N-Tap	8

Always Specify Model & Serial Number

Models: 222 (-003 /-004 /-007 /-008 /-010) | 223 (-003 /-004 /-007 /-008 /-010) | 622 (-002 & -004) | 623 (-002 & -004)
Serial Numbers: All | All | All | All

Drawer Heater System

Refer To:	Page
Fuse Test	B-3
Drawer Heater System Test	B-23
Section D - Wiring Diagrams	D-1
Midmark Upperwrap & Footrest Shelf	E-16.1

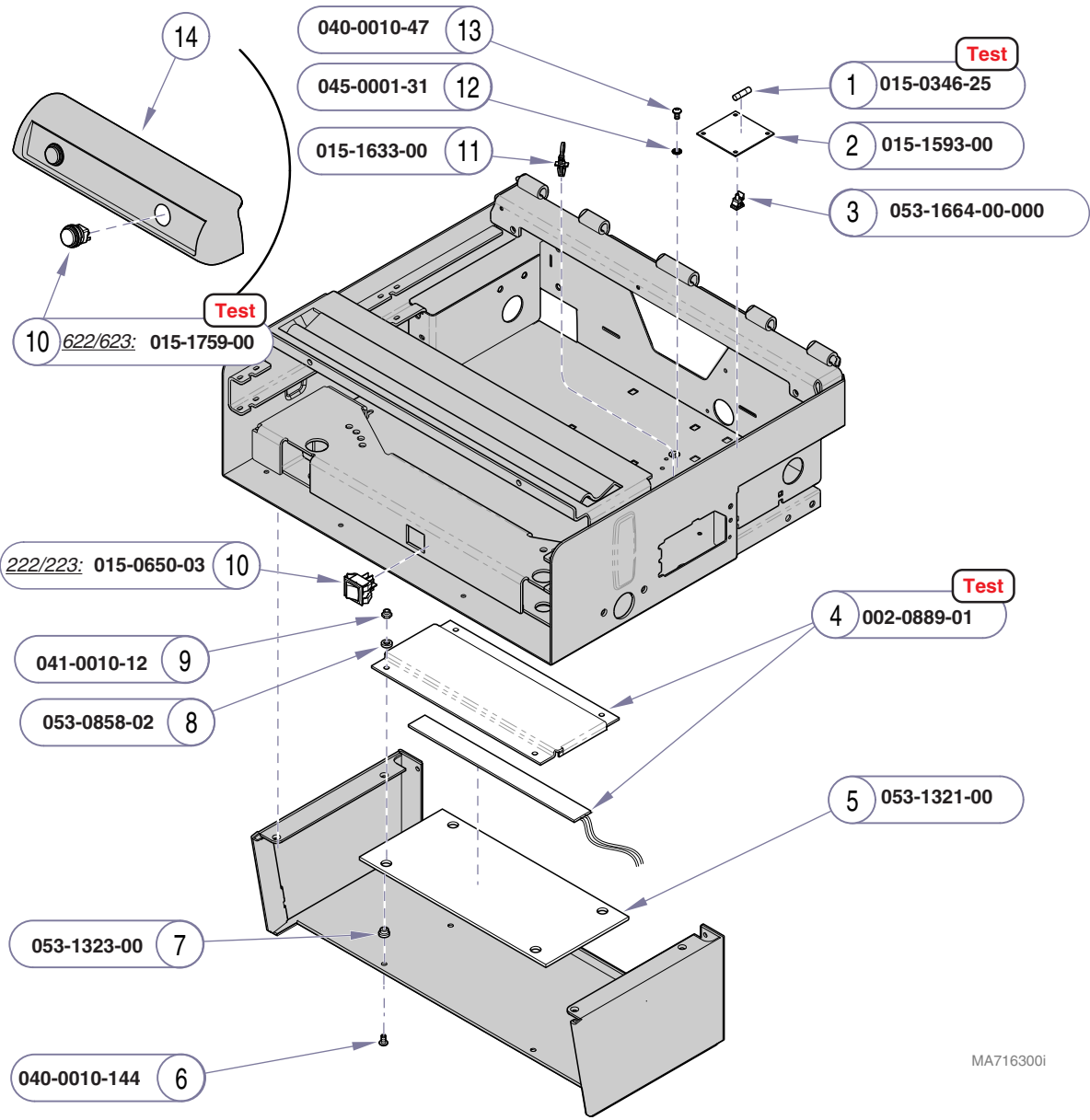

MA7163001

Item	Description	Qty.
1	• Fuse	2
	(800 mA, 250V, Slo-Blo, 5 x 20mm)	
2	• Distribution Board	1
3	• PC Board Standoff	4
4	• Heater Plate Assembly	1
5	• Heater Insulation	1
6	• Screw (10-32x 1/2")	4
7	• Nylon Shoulder Washer	4
8	• Nylon Washer	4
9	• Nylon Nut	4
10	• Drawer Heater Switch	1
11	• Wrap-N-Tap	3
12	• Lockwasher (#10)	1
13	• Screw (#10-24 x 3/8")	1
14	Refer to: Midmark Upperwrap & Footrest Shelf"	Ref

Always Specify Model & Serial Number

E-30.1

Drawer Heater System

Models:	222 (-016)	223 (-016)	622 (-008)	623 (-008/-010/-011)
Serial Numbers:	All	All	All	All

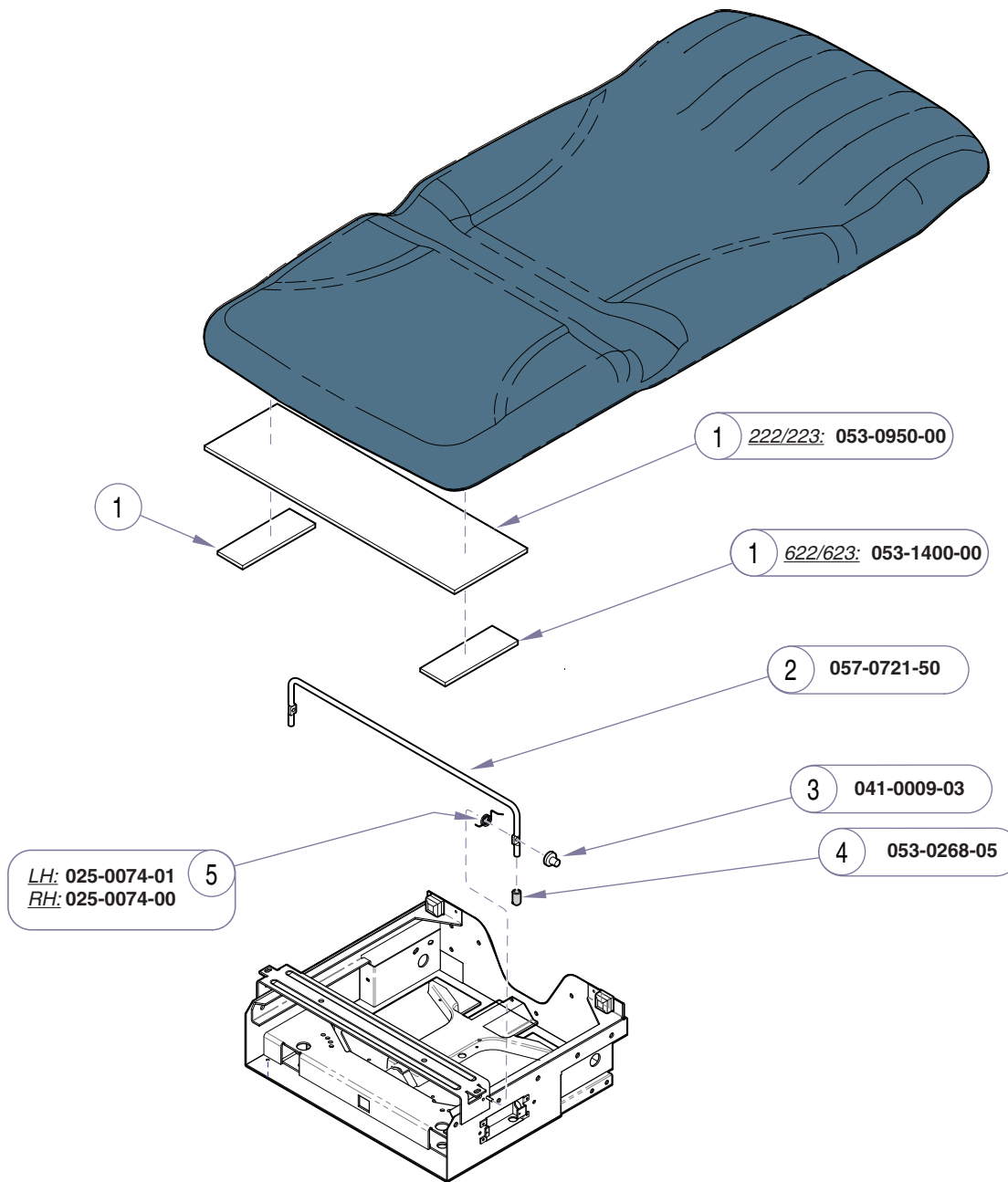

MA612201i

Item	Description	Qty.
1	• Scuff Plate	1 / 2
2	• Pelvic Lift	1
3	• Push Nut	2
4	• Vinyl End Cap	2
5	• Pelvic Lift Spring (LH shown)	2

Always Specify Model & Serial Number

Models:	222	223	622	622
Serial Numbers:	(-003 /-004 /-007 thru -010) All	(-003 /-004 /-007 thru -010) All	(-002 /-003 /-004 /-006) All	(-002 /-003 /-004 /-006) All

Pelvic Tilt

Refer To:	Page
Upperwrap & Footrest Shelf:	
Ritter models	E-15.2
Midmark models	E-16.1

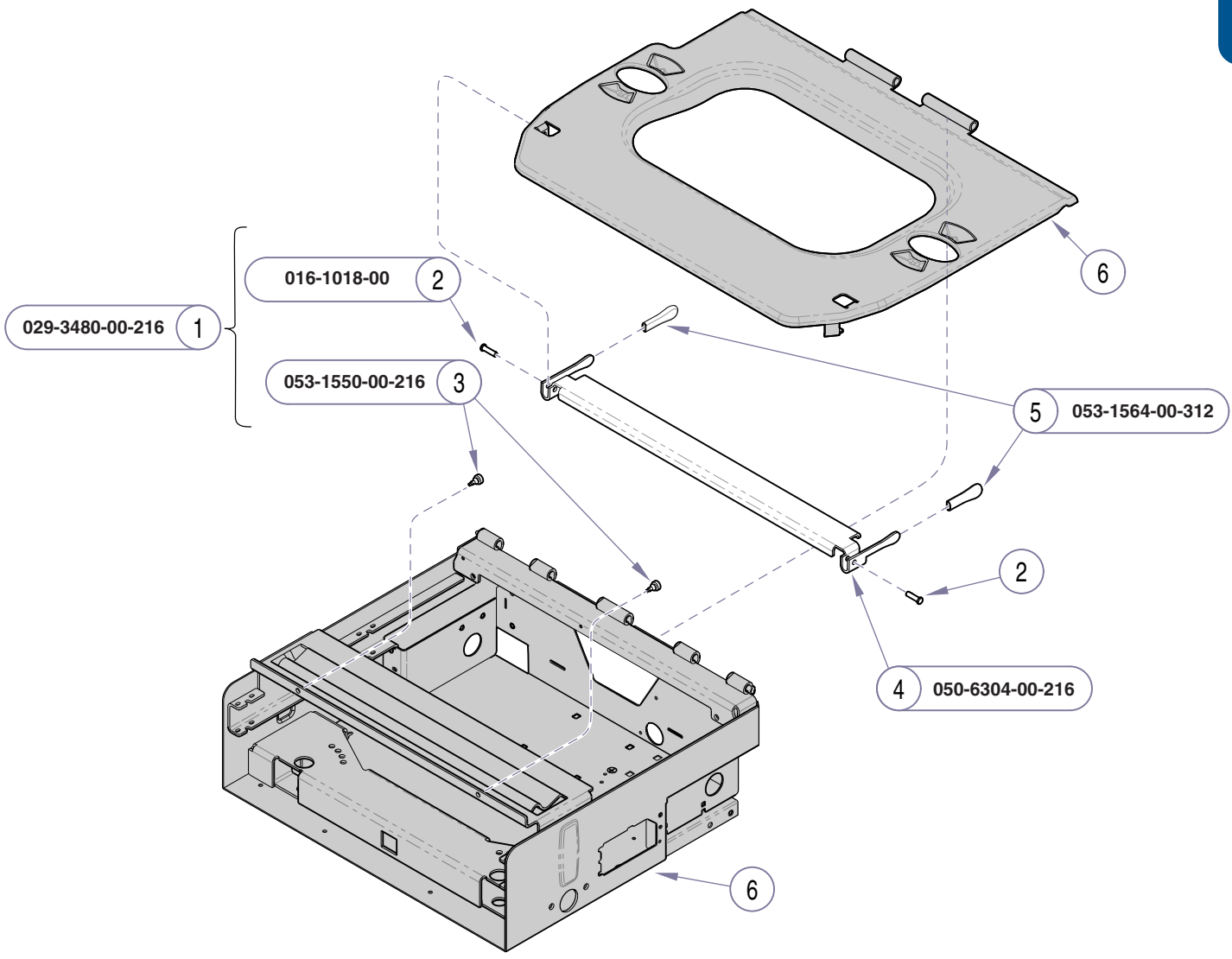

Item	Description	Qty.
1	Pelvic Tilt Assembly (includes items 2 thru 5)	1
2	• Pivot Pin	2
3	• Bumper	2
4	• Bracket	1
5	• Handle	2
6	Refer to: "Upperwrap & Footrest Shelf" ... Ref	

Always Specify Model & Serial Number

MA7162001

E-31.1

Pelvic Tilt

Models:	222 (-016 & -017)	223 (-016)	622 (-008)	623 (-008 thru -010)
Serial Numbers:	All	All	All	All

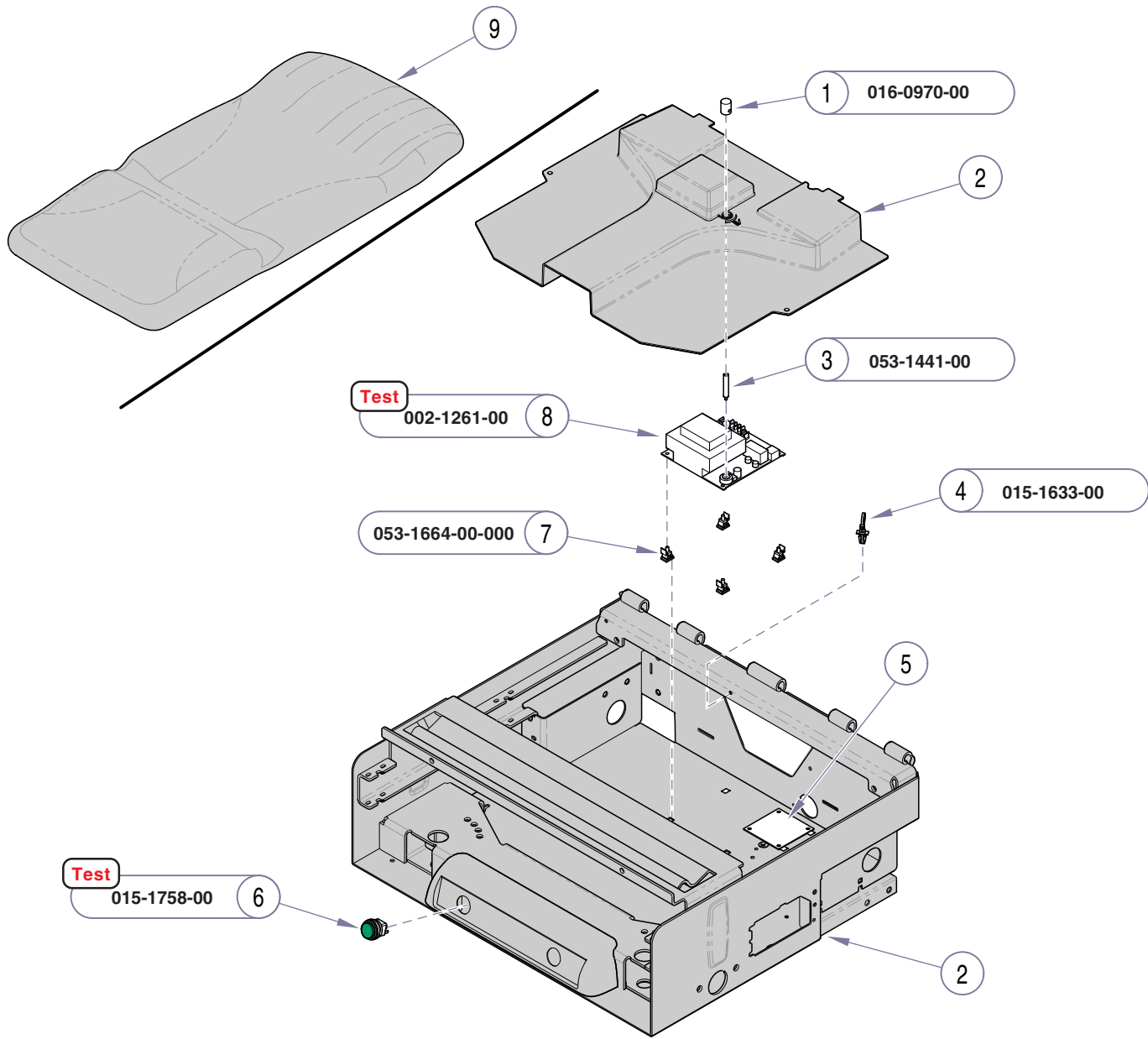

Refer To:	Page
Uph. Heater System Test	B-29
Upholstery - Midmark:	
Premium	E-8*
Ultra-Premium	E-9*
Midmark Upperwrap & Footrest Shelf	E-16*
Drawer Heater System	E-30*
* multiple pages due to model / serial # break	

Item	Description	Qty.
1	Adjustment Knob	1
2	Refer to: "Midmark Upperwrap & Footrest Shelf"	Ref
3	Adjustment Shaft	1
4	Wrap-n-Tap Wire Tire	3
5	Refer to: "Drawer Heater System"	Ref.
6	Upholstery Heater Switch (green)	1
7	PC Board Standoffs	4
8	Upholstery Heater PC Board Kit (includes item 2)	1
9	Refer to: "Upholstery - Midmark"	Ref

Always Specify Model & Serial Number

MA716400i

Models: 622 (-002 /-004 /-006 /-008) | 623 (-002 /-004 /-006 /-008 /-010)
Serial Numbers: V2200 thru V857486 | V2200 thru V857486

**Upholstery Heater
Components**

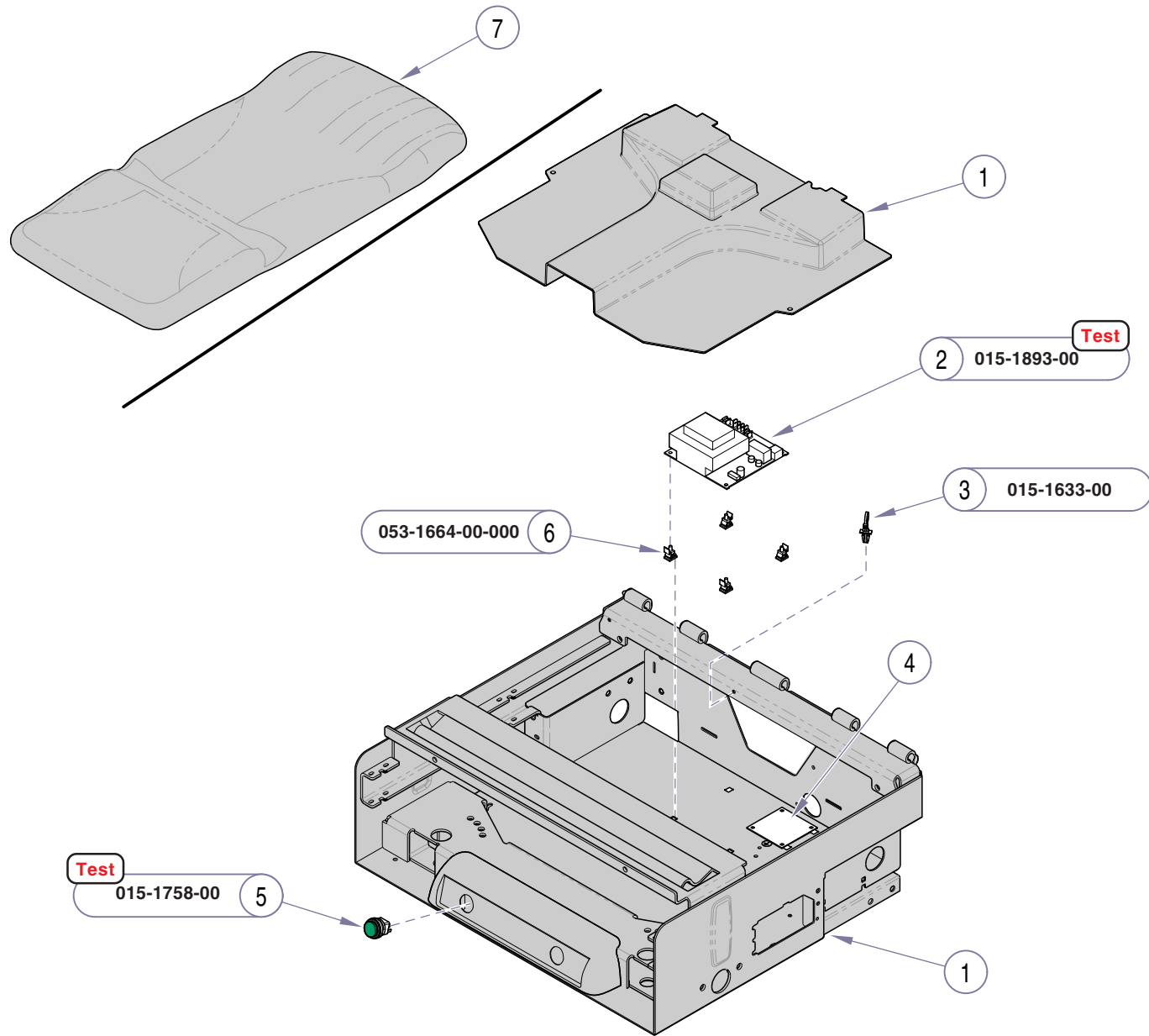

Refer To:	Page
Uph. Heater System Test	B-29
Upholstery - Midmark:	
Premium	E-8*
Ultra-Premium	E-9*
Midmark Upperwrap & Footrest Shelf	E-16*
Drawer Heater System	E-30*
* multiple pages due to model / serial # break	

Item	Description	Qty.
1	Refer to: "Midmark Upperwrap & Footrest Shelf"	Ref
2	Upholstery Heater PC Board	1
3	Wrap-n-Tap Wire Tire	3
4	Refer to: "Drawer Heater System"	Ref.
5	Upholstery Heater Switch (green)	1
6	PC Board Standoffs	4
7	Refer to: "Upholstery - Midmark"	Ref

Always Specify Model & Serial Number

MA716401i

E-32.1

Upholstery Heater Components

Models: 622 (-002 /-004 /-006 /-008) | 623 (-002 /-004 /-006 /-008 /-010)
Serial Numbers: V857487 thru present | V857487 thru present

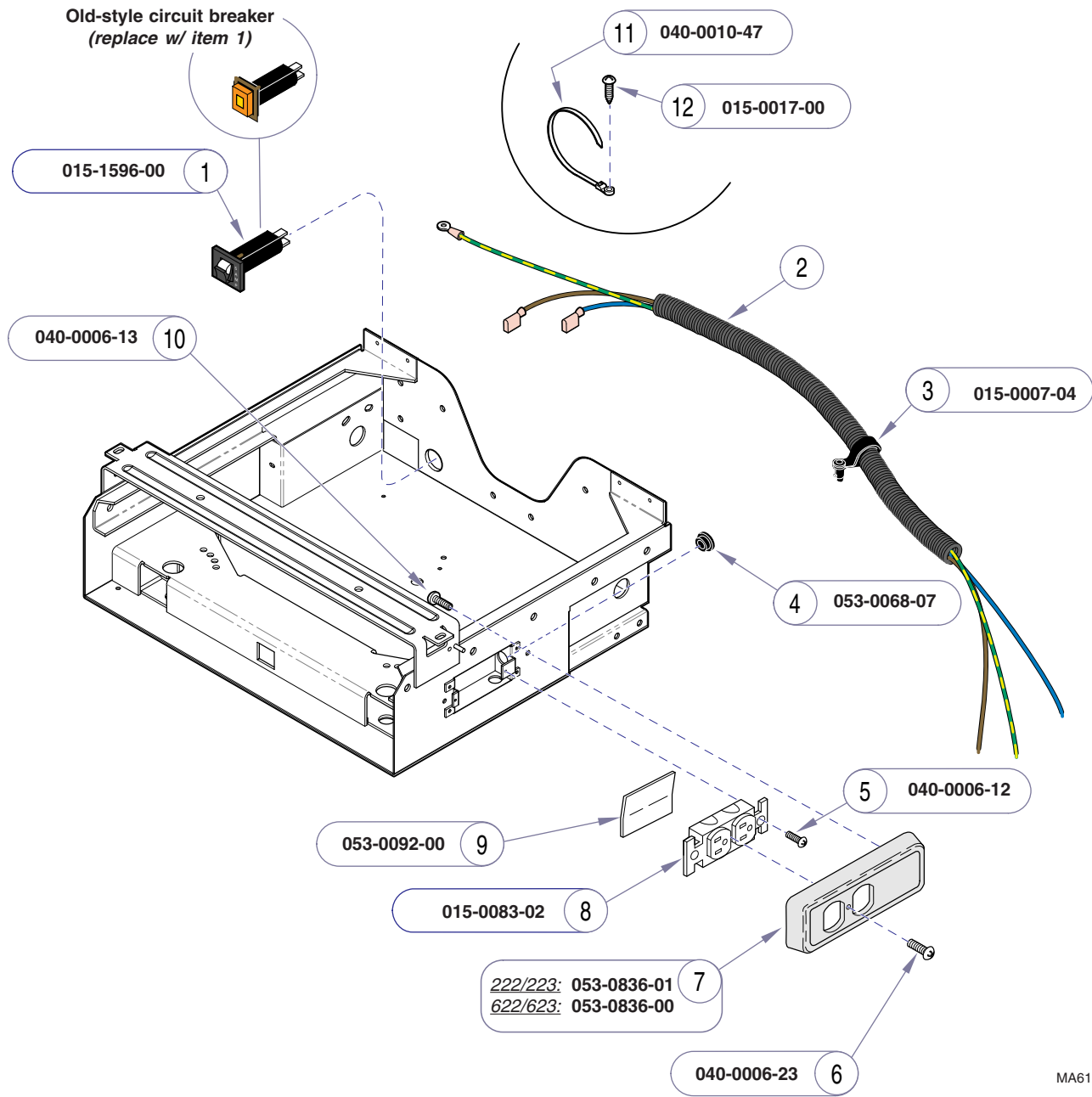

Item	Description	Qty.
1	Circuit Breaker* 1 *not used on Canadian models: 222 / 223 (-011 thru -014) 623 / 623 (-005 & -006)	1
2	Refer to: Section D - Wiring Diagrams	Ref
3	Wrap-N-Tap	3
4	Snap Bushing	1
5	Screw	2
6	Flat Head Screw (#6-32 x 1")	1
7	Receptacle Cover	1
8	Duplex Receptacle	1
9	Insulator	1
10	Screw (#6-32)	2
11	Cable Tie (w/screw hole)	4
12	Screw (#10-24 x .37")	4

Always Specify Model & Serial Number

MA6121031

Table Receptacle System

Models: Serial Numbers:	222 (-002 /-004 /-006 /-008) (-011 thru -014) All	223 (-002 /-004 /-006 /-008) (-011 thru -014) All	622 (-001 /-002 /-005 /-006) All	623 (-001 /-002 /-005 /-006) All
----------------------------	--	--	--	--

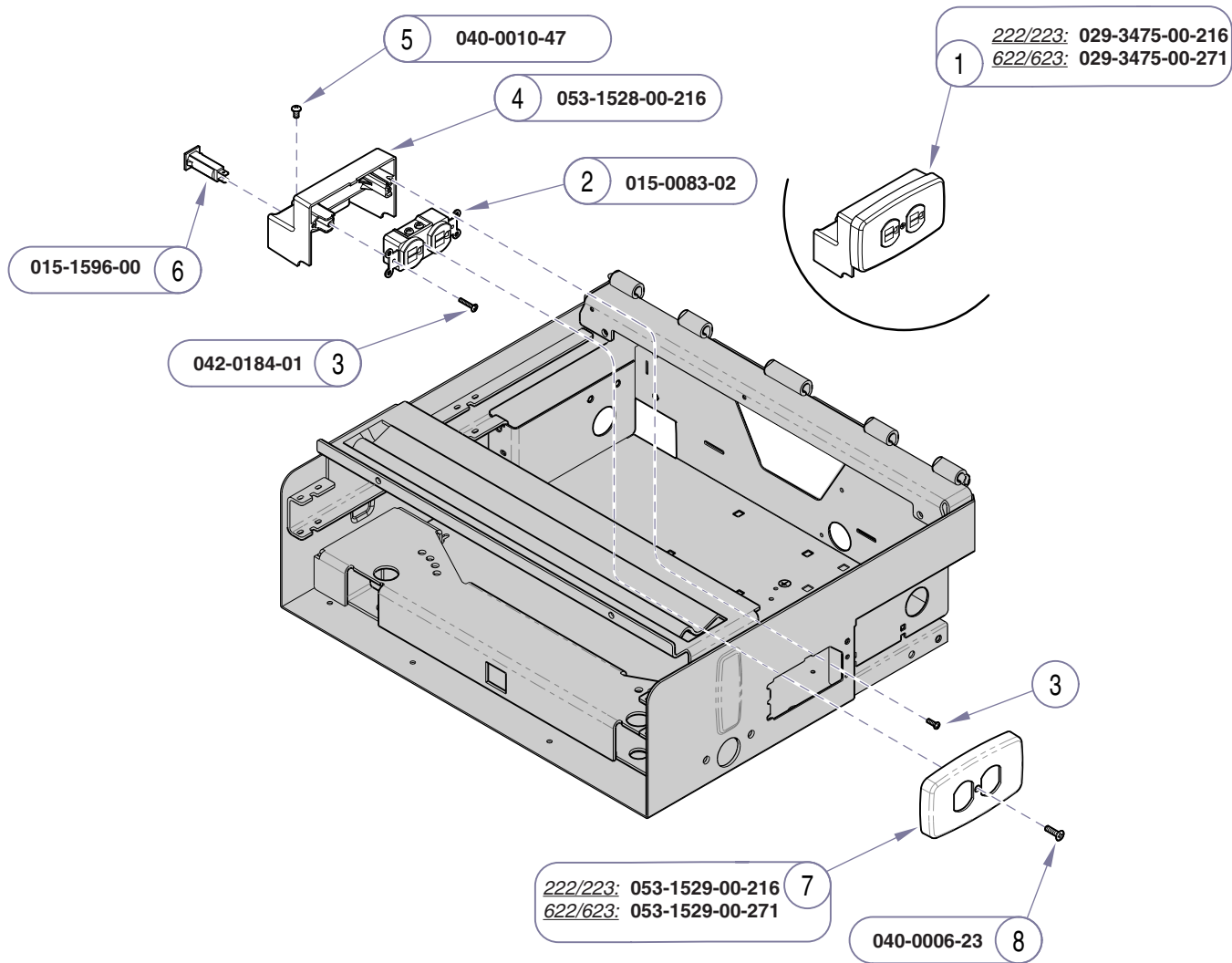

Item	Description	Qty.
1	Table Receptacle Assembly (includes items 2 thru 9)	1
2	• Duplex Receptacle	1
3	• Screw (.138-32 x 1/2")	4
4	• Circuit Breaker Housing	1
5	• Screw (#10-24 x 3/8")	1
6	• Circuit Breaker (5 amp)	2
7	• Receptacle Cover	1
8	• Screw (#6-32 x 1/2")	1

Always Specify Model & Serial Number

MA716100I

Models:	222 (-015 & -016)	223 (-015 & -016)	622 (-007 & -008)	623 (-007 & -008)
Serial Numbers:	All	All	All	All

Table Receptacle System

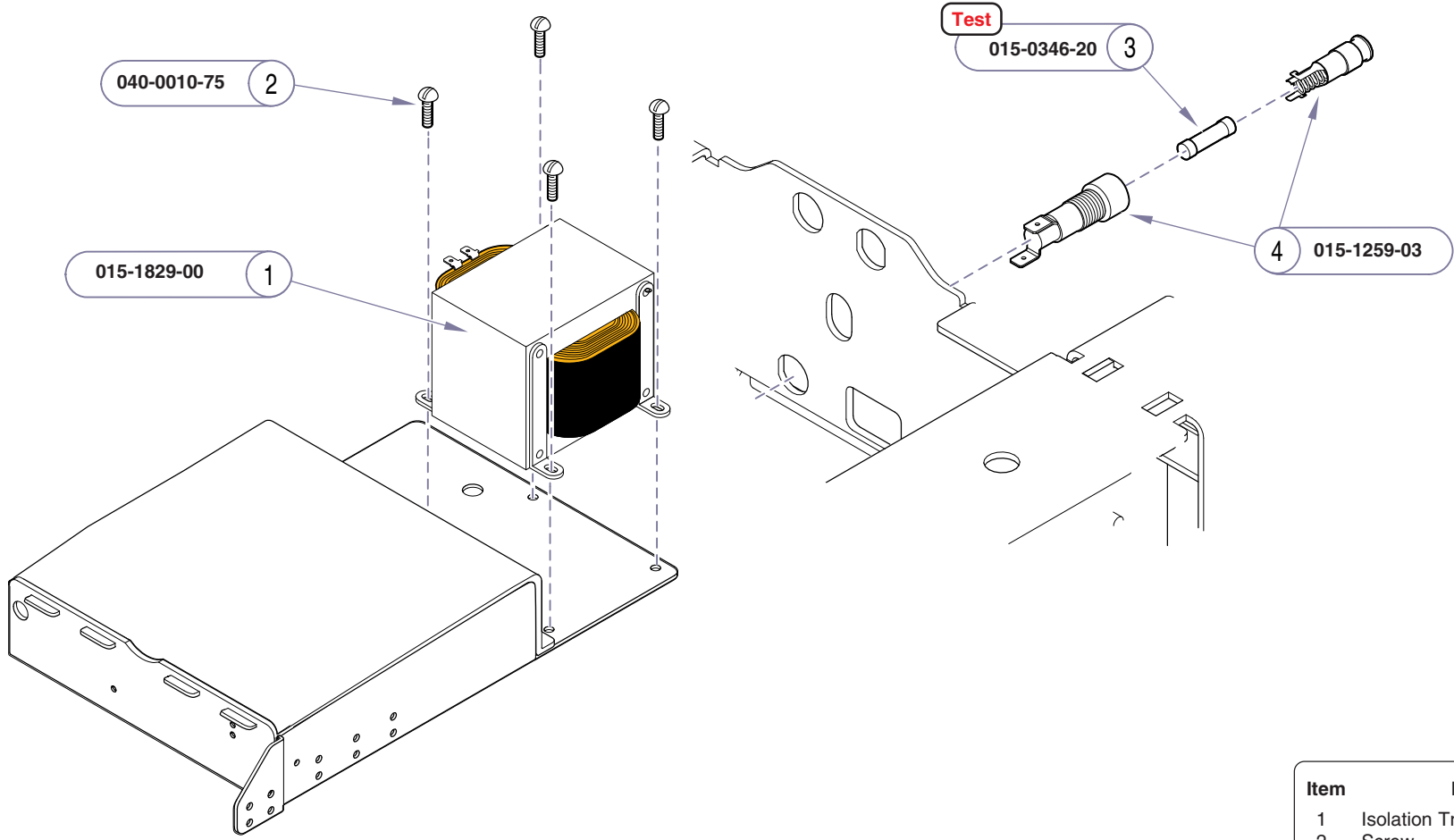

Item	Description	Qty.
1	Isolation Transformer	1
2	Screw	4
3	Fuse (6.3A, 250V, Slo-Blo, 5 x 20 mm)	1
4	Fuse Holder	2

Always Specify Model & Serial Number

MA682100i

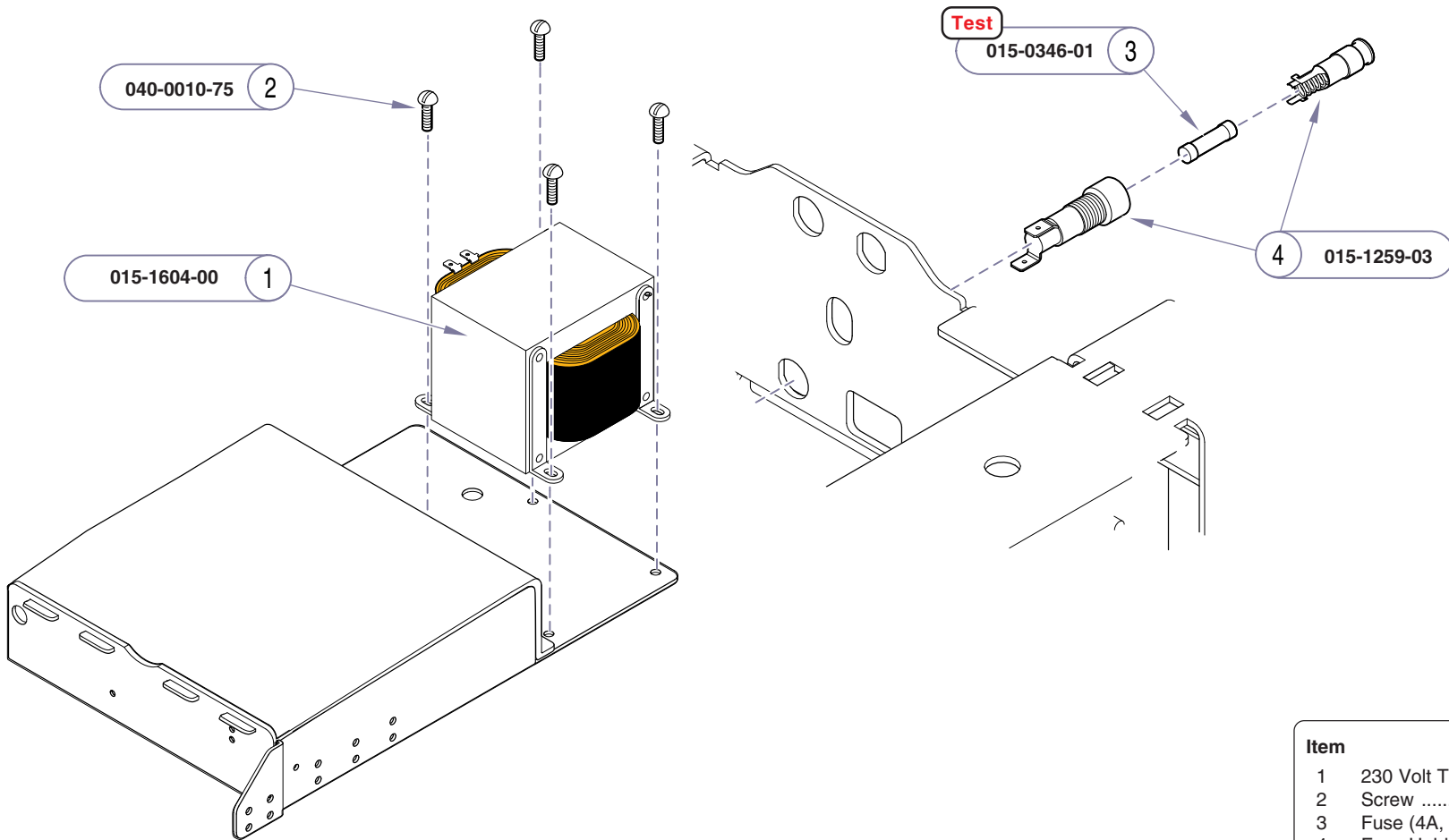

MA6821001

Item	Description	Qty.
1	230 Volt Transformer	1
2	Screw	4
3	Fuse (4A, 250V, Slo-Blo, 5 x 20 mm)	1
4	Fuse Holder	2

Always Specify Model & Serial Number

Models:	222 (-009 /-010 /-017)	223 (-009 & -010)	622 (-003 & -004)	623 (-003 /-004 /-009 / -010)
Serial Numbers:	All	All	All	All

230 Volt Electrical System

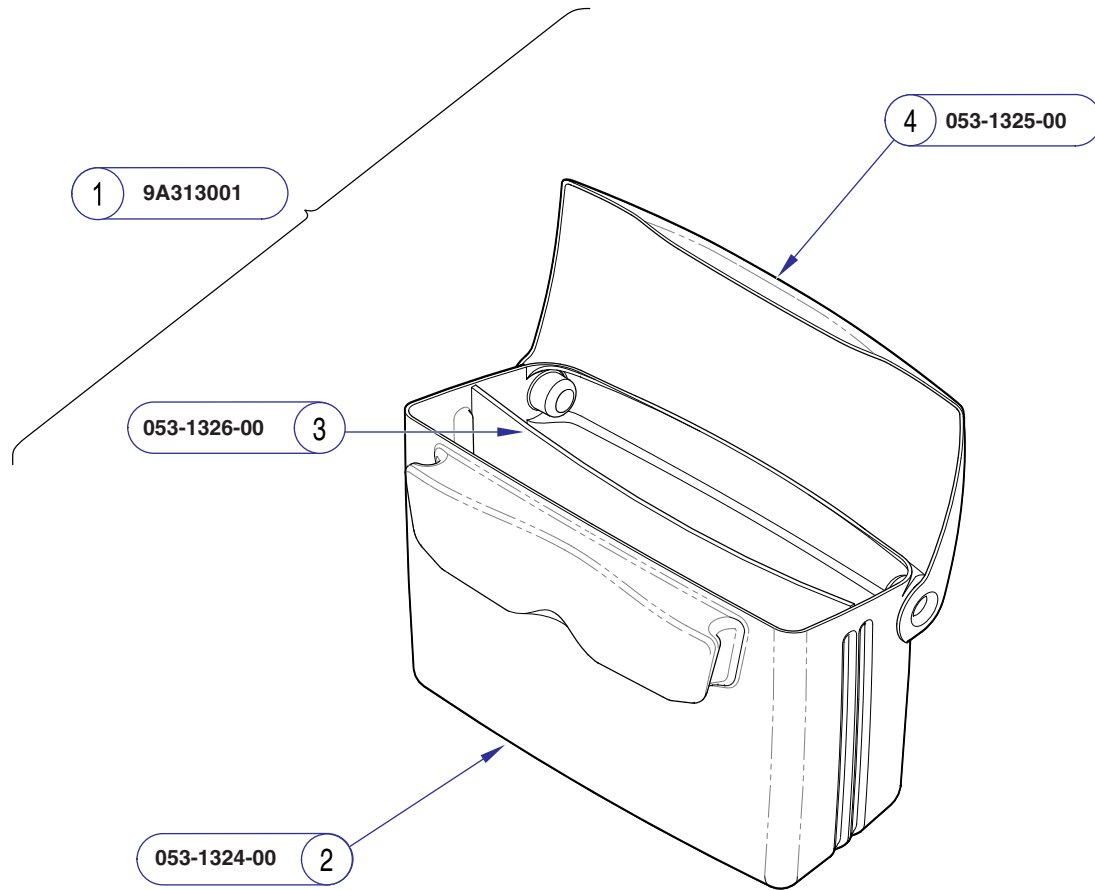

Item	Description	Qty.
1	Storage Pod Assembly	1
	<i>(includes items 2 thru 4)</i>	
2	• Storage Container	1
3	• Storage Divider	1
4	• Storage Container Lid	1

Always Specify Model & Serial Number

MA612900i

Storage Pod

Models:	622 (all)	623 (all)
Serial Numbers:	<i>All</i>	<i>All</i>

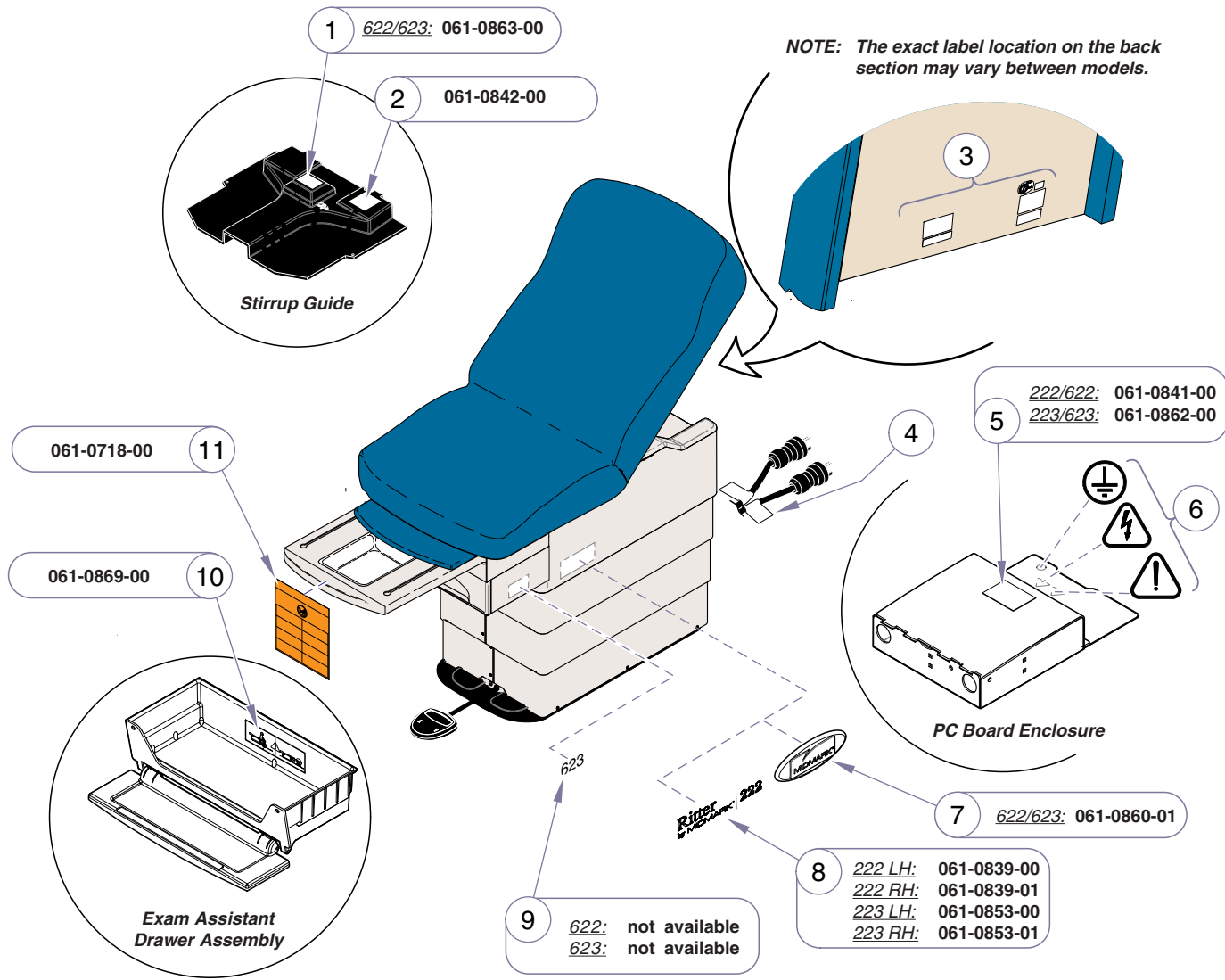

Item	Description	Qty.
1	Fuse Label (<i>Uph. Htr. PC Board</i>)	1
2	Fuse Label (<i>Distribution Board</i>)	1
3	Regulatory Certification Label	1
	Duty Cycle Label	1
	Danger Label (<i>w/Table Receptacle only</i>)	1
	Patent Pending Label	1
	Model / Serial Number Label	1
	Patent Number Label	1
4	Power Cord Label	2
5	Fuse Label (<i>Main PC Board</i>)	1
6	Ground Label	1
	Dangerous Voltage Label	1
	Caution Label	1
7	Midmark Nameplate	2
8	Ritter Model Label (<i>LH shown</i>)	2
9	Midmark Model Label (<i>early models only</i>) ...	2
10	Exam Assistant Drawer Label	1
11	Stirrup Lifting Caution Label	1

Always Specify Model & Serial Number

MA730900i

Models: All
Serial Numbers: All

Label Location

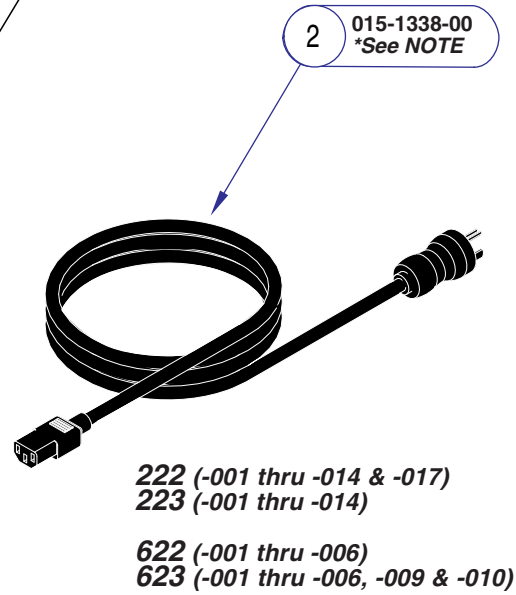
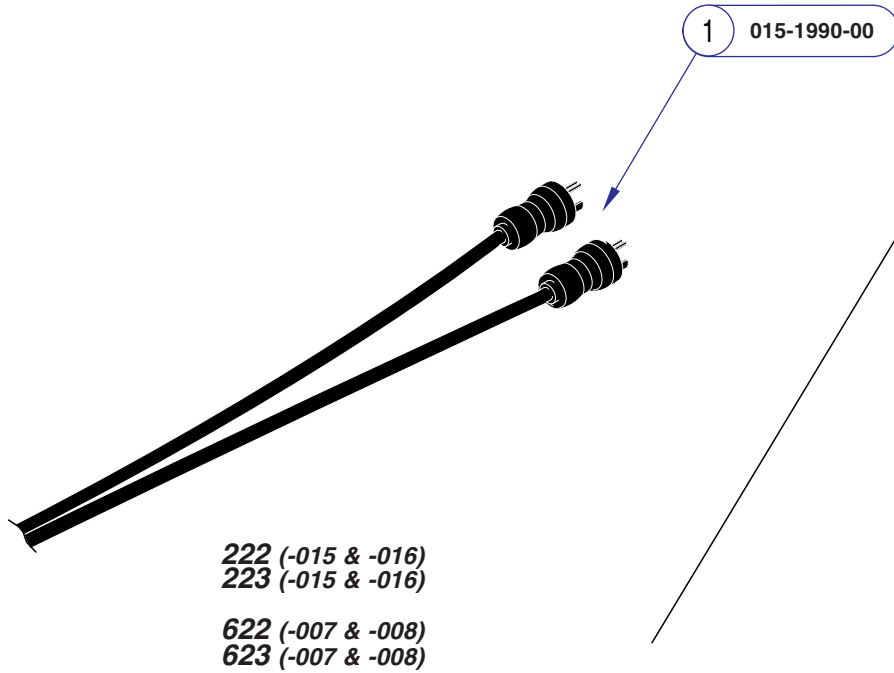

MA8375I

Item	Description	Qty.
1	Power Cord, Conjoined	1
2	Power Cord	1
*NOTE: Export models, 622/623 (-003 /-004) require 9A152 International Cordsets.		
Always Specify Model & Serial Number		

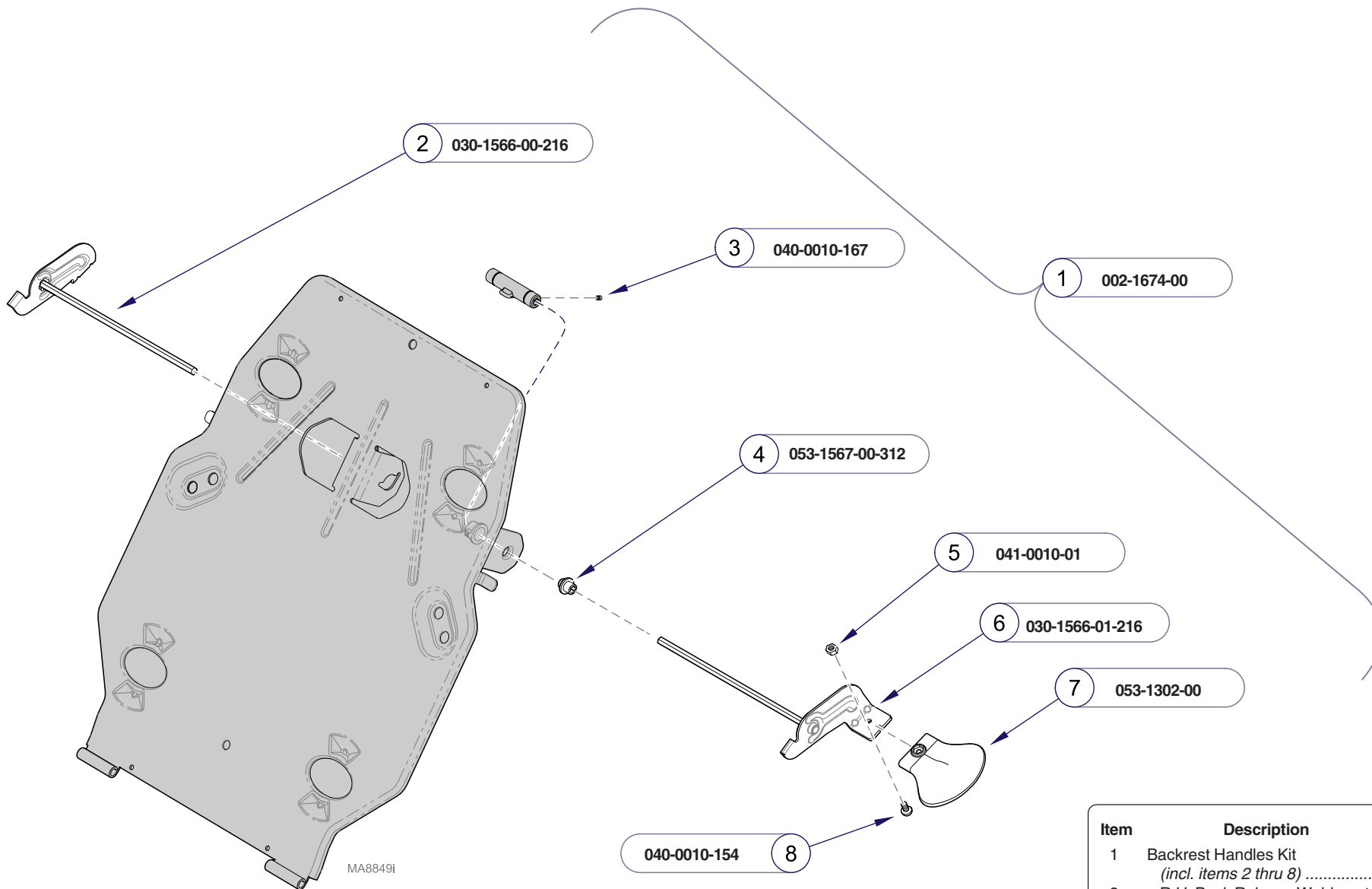

Item	Description	Qty.
1	Backrest Handles Kit <i>(incl. items 2 thru 8)</i>	1
2	• R.H. Back Release Weldment	1
3	• Set Screw	2
4	• Release Rod Bushing	2
5	• Nut (#10-32)	2
6	• L.H. Back Release Weldment	1
7	• Actuator Release Handle	2
8	• Screw (#10-32 X 7/16 flat head phillips)	2

Always Specify Model & Serial Number

Models: | **222 (-015 thru -017)** | **622 (-007 & -008)**
 Serial Numbers: | V216996 thru present | V216996 thru present

Backrest Handles

Midmark Corporation
60 Vista Drive
P.O. Box 286
Versailles, OH 45380-0286
937-526-3662
Fax 937-526-5542
www.midmark.com



Because we care.