

# 413

-001 thru -004

Power Female Procedure  
Examination Chair



## Service and Parts Manual

Serial Number Prefixes:  
BK, V, DT & FH

**NO LONGER IN  
PRODUCTION**  
Some service parts may not  
be available for this product!



**413** -001  
thru  
-004

FOR USE BY MIDMARK TRAINED TECHNICIANS ONLY



# TABLE OF CONTENTS

Section/Paragraph	Page	Section/Paragraph	Page
<b>IMPORTANT INSTRUCTIONS</b>		<b>SECTION V SCHEMATICS AND DIAGRAMS</b>	
General Safety Instructions .....	ii	5.1 Electrical Schematics / Wiring Diagrams .....	5-1
Safety Alert Symbols .....	ii	<b>SECTION VI PARTS LIST</b>	
Warranty Instructions .....	ii	6.1 Introduction .....	6-1
<b>SECTION I GENERAL INFORMATION</b>		6.2 Description of Columns .....	6-1
1.1 Scope of Manual .....	1-1	6.3 Torque Specifications And Important Assembly Notes .....	6-1
1.2 How to Use Manual .....	1-1	Pictorial Index .....	6-2
1.3 Description of 413 Power Female Procedures Chair .....	1-1	Labels and Decals .....	6-3
1.4 Specifications .....	1-3	Upholstery .....	6-4
1.5 Parts Replacement Ordering .....	1-5	Main Frame Section .....	6-5.*
1.6 Special Tools .....	1-5	Stirrup Assembly .....	6-6
<b>SECTION II TESTING AND TROUBLESHOOTING</b>		Stirrups .....	6-7.*
2.1 Operational Test .....	2-1	Arm Rest Assembly .....	6-8.*
2.2 Troubleshooting Procedures .....	2-2	Cross Support .....	6-9.*
<b>SECTION III SCHEDULED MAINTENANCE</b>		Base Components .....	6-10.*
3.1 Scheduled Maintenance .....	3-1	Base Actuator .....	6-11.*
<b>SECTION IV MAINTENANCE/SERVICE INSTRUCTIONS</b>		Base And Panels .....	6-12.*
4.1 Introduction .....	4-1	Linkage Assembly .....	6-13.*
4.2 Seat Up Limit Switch Removal / Installation .....	4-1	Pan Assembly .....	6-14.*
4.3 Seat Actuator Removal / Installation .....	4-2	Footrest Assembly .....	6-15.*
4.4 Pan Safety Limit Switch Removal / Installation .....	4-4	Seat Components .....	6-16*
4.5 Gas Spring Removal / Installation .....	4-6	Seat Actuator .....	6-17.*
4.6 Base Actuator Removal / Installation .....	4-7	Footswitch .....	6-18
4.7 Typical Capacitor Removal / Installation .....	4-9	Back Panel .....	6-19.*
4.8 Typical Actuator Motor / Actuator Brake Removal / Installation .....	4-10	Wiring Locations .....	6-20
4.9 Base Down Limit Switch or Seat Down Limit Switch Removal / Installation .....	4-11	Export .....	6-21
4.10 Typical Foot Pedal Footswitch Removal / Installation .....	4-13	<b>COMMENTS</b> .....	
		<b>FAX ORDERING FORM</b> .....	
			7-1
			7-2

(\*) Indicates that there has been a serial number break for the illustration and that there are additional point page(s) following the original page.

# IMPORTANT INSTRUCTIONS

## General Safety Instructions

**Safety First:** The primary concern of Midmark Corporation is that this Power Female Procedures Chair is maintained with the safety of the patient and staff in mind. To assure that services and repairs are completed safely and correctly, proceed as follows:

- (1) Read this entire manual before performing any services or repairs on this chair.
- (2) Be sure you understand the instructions contained in this manual before attempting to service or repair this chair.

## Safety Alert Symbols

Throughout this manual are safety alert symbols that call attention to particular procedures. These items are used as follows:



### DANGER

A DANGER is used for an imminently hazardous operating procedure, practice, or condition which, if not correctly followed, will result in loss of life or serious personal injury.



### WARNING

A WARNING is used for a potentially hazardous operating procedure, practice, or condition which, if not correctly followed, could result in loss of life or serious personal injury.



### CAUTION

A CAUTION is used for a potentially hazardous operating procedure, practice, or condition which, if not correctly followed, could result in minor or moderate injury. It may also be used to alert against unsafe practices.



### EQUIPMENT ALERT

An EQUIPMENT ALERT is used for an imminently or potentially hazardous operating procedure, practice, or condition which, if not correctly followed, will or could result in serious, moderate, or minor damage to unit.

### NOTE

A NOTE is used to amplify an operating procedure, practice or condition.

## Warranty Instructions

Refer to the Midmark "Limited Warranty" printed on the back cover of the Installation and Operation Manual for warranty information. Failure to follow the guidelines listed below will void the warranty and / or render the 413 Power Female Procedures Chair unsafe for operation.

- In the event of a malfunction, do not attempt to operate the chair until necessary repairs have been made.
- Do not attempt to disassemble chair, replace malfunctioning or damaged components, or perform adjustments unless you are one of Midmark's authorized service technicians.
- Do not substitute parts of another manufacturer when replacing inoperative or damaged components. Use only Midmark replacement parts.

**SECTION I  
GENERAL INFORMATION**

**1.1 Scope of Manual**

This manual contains detailed troubleshooting, scheduled maintenance, maintenance, and service instructions for 413 Power Female Procedures Chair. This manual is intended to be used by Midmark's authorized service technicians.

**1.2 How to Use Manual**

- A. Manual Use When Performing Scheduled Maintenance.
  - (1) Perform inspections and services listed in Scheduled Maintenance Chart (Refer to para 3.1).
  - (2) If a component is discovered to be faulty or out of adjustment, replace or adjust component in accordance with maintenance / service instructions (Refer to para 4.1).
- B. Manual Use When Chair Is Malfunctioning And Cause Is Unknown.
  - (1) Perform an operational test on chair (Refer to para 2.1).
  - (2) Perform troubleshooting procedures listed in Troubleshooting Guide (Refer to para 2.2).
  - (3) If a component is discovered to be faulty or out of adjustment, replace or adjust component in accordance with maintenance / service instructions (Refer to para 4.1).
- C. Manual Use When Damaged Component Is Known.
  - (1) Replace or adjust component in accordance with maintenance / service instructions (Refer to para 4.1).

**1.3 Description Of 413 Power Female Procedures Chair**

**A. General Description (See Figure 1-1).**

The 413 Power Female Procedures Chair is an examination chair designed for performing female specific

examinations and procedures on female patients; especially Lithotomy procedures.

The major serviceable components of the chair are the seat actuator, seat capacitor, base actuator, base capacitor, gas spring, pan safety limit switch, seat up limit switch, seat down limit switch, base down limit switch, and the foot control which includes four foot switches.

**B. Theory of Operation** (See Figure 5-1, Sheets 1 and 2 for domestic wiring diagrams, Figure 5-2, Sheets 1 and 2 for export wiring diagrams, Figure 5-3 for domestic electrical schematic, and Figure 5-4 for export electrical schematic.)

Electrical Power:

Line voltage is supplied directly to the footswitches of the chair. Also, line voltage is always present at the receptacle (domestic units only).

Chair Operation:

Power is present at all four foot control footswitches. However, the BASE DOWN and SEAT UP switches receive their power thru the BASE UP and SEAT DOWN footswitches, respectively. So, if the BASE UP footswitch is depressed, power is removed from the BASE DOWN footswitch and if the SEAT DOWN footswitch is depressed, power is removed from the SEAT UP footswitch. This wiring setup prevents the operator from trying to run the actuator in an up and down direction simultaneously and causing damage to the actuator.

SEAT UP function:

When the operator depresses the SEAT UP footswitch, current is applied across the seat actuator motor windings thru the normally open (N.O.) pan safety limit switch and seat capacitor, causing the seat actuator to run. The pan safety limit switch is a N.O switch. When the pan assembly is in its stowed position, the pan safety limit switch is tripped, closing the circuit and allowing the seat actuator to run. If the pan assembly is not in its stowed position, the pan safety limit switch is not tripped, which opens the circuit and prevents the seat actuator from running. This prevents the operator

# SECTION I GENERAL INFORMATION

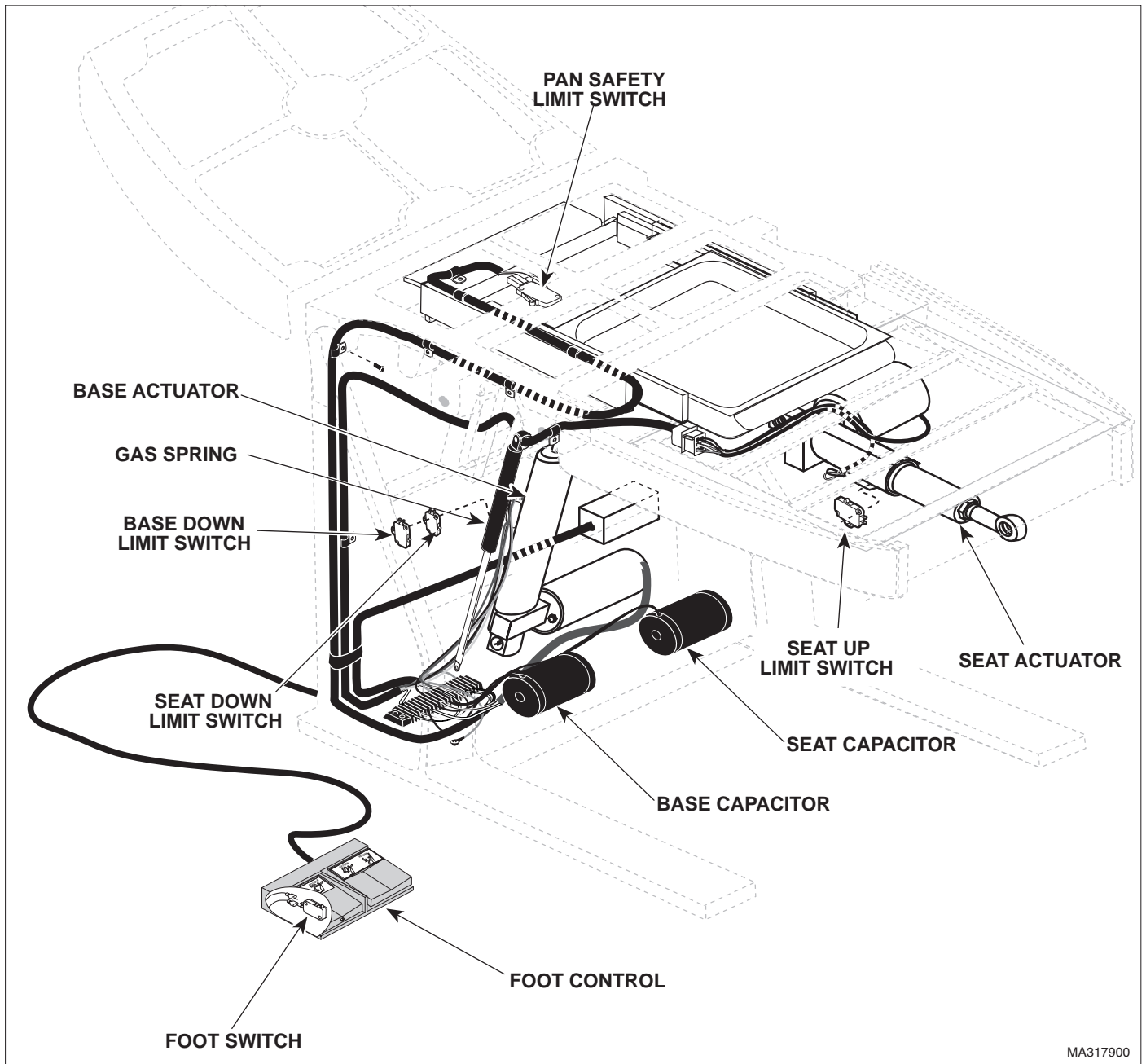

MA317900

**Figure 1-1. Major Components**

from running the foot section into the pan assembly and damaging it. The seat capacitor provides motor start and motor run power for the seat actuator.

**BASE DOWN function:**

When the BASE DOWN footswitch is depressed, current is applied across the base actuator motor coil thru either the seat up limit switch or the base down limit switch and base capacitor, causing the base

actuator to run. The seat up limit switch is a normally closed (N.C.) switch which is tripped when the seat function is in any position, but all the way up, resulting in an open circuit. This prevents the operator from running the BASE DOWN function (lower than the 2/3 up position - see base down limit switch operation) when the seat is in any position, but all the way up, preventing an accidental seat section collision with floor. When the seat function is raised all the way up, the seat up limit switch untrips, closing the circuit, and

# SECTION I GENERAL INFORMATION

allowing the BASE DOWN function to be operated to any position.

The base down limit switch is a N.C. switch which is tripped when the base function is between the all the way down position to approximately the 2/3 up position, resulting in an open circuit. This means that the switch is untripped only when the base function is in 2/3 up position to all the way up position, resulting in a closed circuit. This only allows the operator to lower the BASE DOWN function down to the 2/3 up position. Then the base down limit switch trips, opening the circuit, and preventing further downward movement of the base actuator. This prevents an accidental seat section collision with floor. The base capacitor provides motor start and motor run power for the base actuator.

So, if the seat up limit switch is tripped (seat function *is not* in all the way up position), the base down limit switch provides the base actuator with current; this allows you to lower table top only 1/3 of way down. But, if the seat up limit switch is untripped (seat function *is* in all the way up position), the seat up limit switch provides the base actuator with current; this allows you to lower table top all the way down.

### BASE UP function:

When the BASE UP footswitch is depressed, current is applied across the base actuator motor coil and base capacitor, causing the base actuator to run. The base capacitor provides motor start and motor run power for the base actuator.

### SEAT DOWN function

When the SEAT DOWN footswitch is depressed, current is applied across the seat actuator motor coil thru the seat down limit switch and seat capacitor. The seat down limit switch is a N.C. switch which is tripped when the base function is between the all the way down position to approximately the 2/3 up position, resulting in an open circuit. This means that the switch is untripped only when the base function is in the 2/3 up position to all the way up position, resulting in a closed circuit. This only allows the operator to lower the SEAT DOWN function if the base actuator is in 2/3 up position or higher. This prevents an accidental seat section collision with floor. The seat capacitor provides motor start and motor run power for the seat actuator.

## 1.4 Specifications

Factual data for the 413 Female Procedures Chair is provided in Table 1-1. Also, see Figure 1-2.

**Table 1-1. Specifications**

Description	Data
<b>Weight:</b>	
Without Shipping Carton .....	374 lb (169.6 kg)
With Shipping Carton .....	412 lb (186.9 kg)
Shipping Carton .....	55 in. "L" x 33 in. "W" x 44 in. "H" (139.7 cm x 83.8 cm x 111.7 cm)
<b>Dimensions (See Figure 1-2):</b>	
Table Top Length (w/o foot section extended) .....	55.5 in. (141.0 cm)
Table Top Length (w/ foot section fully extended) .....	72.7 in. (184.6 cm)
Table Top Width (w/ armrests) .....	28 in. (71.1 cm)
Maximum width of upholstery .....	22 in. (55.9 cm)
Overall Width .....	28 in. (71.1 cm)
<b>Chair Positioning:</b>	
Seat height in chair position .....	19 in. (48.3 cm)
Height in table position .....	34 in. (86.4 cm)
Maximum pelvic area height .....	36 in. (91.4 cm)
<b>Chair Speeds (@ 60 Hz.):</b>	
Base Up .....	9 ±1 seconds
Seat Up .....	9 ±1 seconds
Weight Capacity (Maximum) .....	300 lb. (136.0 kg)
<b>Electrical Requirements:</b>	
115 VAC Unit.....	110 - 120 VAC, 60 HZ, 6 amp, single phase
230 VAC Unit.....	220 - 240 VAC, 50/60 HZ, 5 amp, single phase
<b>Power Consumption:</b>	
115 VAC Unit .....	720 WATTS, 6 amps @ 120 VAC
230 VAC Unit.....	1200 WATTS, 5 amps @ 240 VAC
<b>Recommended Circuit:</b>	
A separate (dedicated) circuit is recommended for this chair. The chair <i>should not</i> be connected to an electrical circuit with other appliances or equipment unless the circuit is rated for the additional load.	

**SECTION I  
GENERAL INFORMATION**

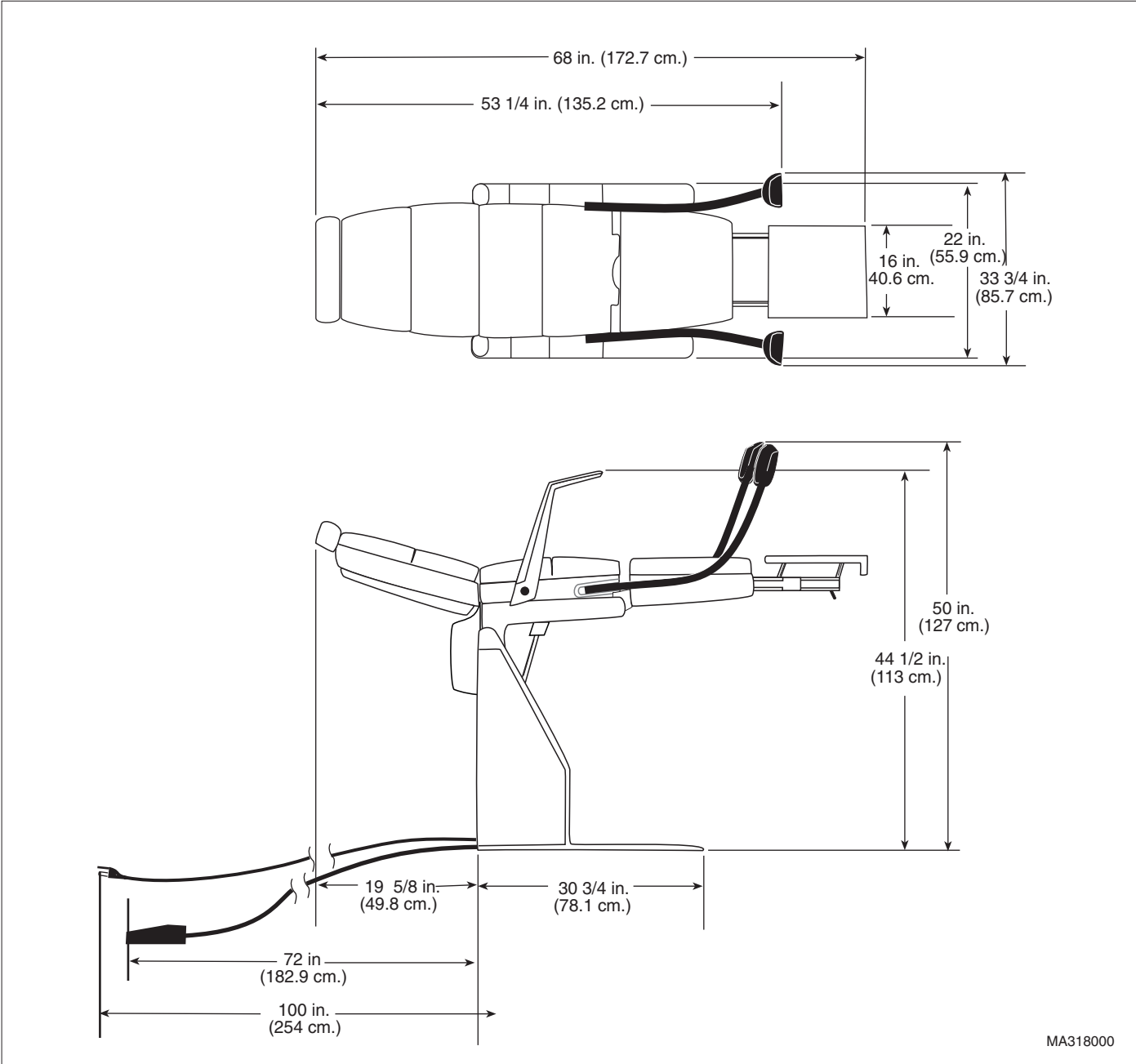

MA318000

**Figure 1-2. Chair Dimensions**



**1.5 Parts Replacement Ordering**

If a part replacement is required, order the part directly from the factory as follows:

- (1) Refer to Figure 1-3 to determine the location of the model number and serial number of the chair and record this data.
- (2) Refer to the Parts List to determine the item numbers of the parts, part numbers of the parts, descriptions of the parts, and quantities of parts needed and record this data (Refer to para 6.1).

**NOTE**

Ask the Purchasing Department of the company that owns the chair for this information. Otherwise, this information may be obtained from the dealer that sold the chair.

- (3) Determine the installation date of the chair and record this data.
- (4) Call Midmark with the recorded information and ask for the Medical Products Technical Services Department. See back cover of this manual for the phone number or use the Fax Order Form (See page 7-2 for Fax Order Form).

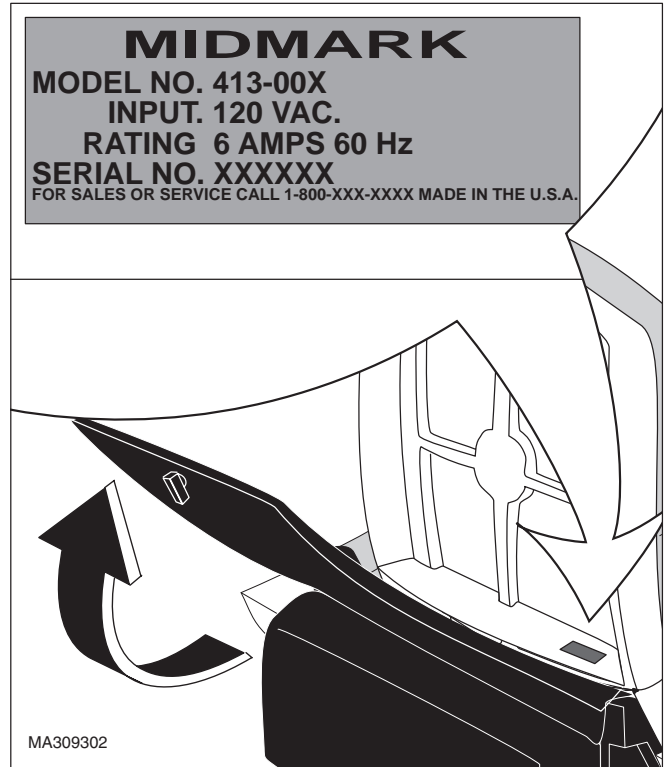

**Figure 1-3. Model Number / Serial Number Location**

**1.6 Special Tools**

Table 1-2 lists all of the special tools needed to repair the chair, how to obtain the special tools, and the purpose of each special tool.

**Table 1-2. Special Tool List**

Description of Special Tool	Manufacturer's Name / Address / Phone	Manufacturer's Part Number	Purpose of Special Tool
Multimeter	Commercially Available	Any Type	Used to perform continuity and voltage checks.
Torque Wrench	Commercially Available	Any Type	Used to tighten hardware to specified torque values.



**SECTION II  
TESTING AND TROUBLESHOOTING**

**2.1 Operational Test**

In order to effectively diagnose the malfunction of the chair, it may be necessary to perform an operational test as follows:



**DANGER**

Refer to the Operator Manual for complete instructions on operating the chair. Failure to do so could result in personal injury.

**NOTE**

The Operational Test, for the most part, only describes what should happen when the chair is operated. If the chair does something other than described, a problem has been discovered. Refer to the Troubleshooting Guide to determine the cause of the problem and its correction.

- (1) Plug the chair into a grounded, non-isolated, correctly polarized outlet, that has the proper voltage output for the chair.

**NOTE**

Pan holder assembly should be pushed in fully for the following step.

- (2) Depress BASE UP, SEAT DOWN, SEAT UP, and BASE DOWN footswitches in this order.
- (3) Observe. The table top should move in the direction corresponding to the footswitch which is being depressed and at the speeds listed below:  
Chair Speeds (@ 60 Hz.):  
Base Down to Base Up in 9 +/-1 seconds  
Seat Down to Seat Up in 9 +/-1 seconds  
The actuator assembly should not drift after the footswitch is released. The actuator assembly should not make excessive squealing noises.
- (4) Raise BASE UP function all the way up.
- (5) Depress SEAT DOWN footswitch and lower seat section halfway. Then raise SEAT UP function all the way up.
- (6) Observe. Seat actuator should run.

- (7) Depress BASE DOWN footswitch and lower table top all the way down; then depress SEAT DOWN footswitch.
- (8) Observe. After the BASE DOWN function is lowered all the way down, the seat actuator should not run when the SEAT DOWN footswitch is depressed.
- (9) Run BASE UP function all the way up and then run SEAT DOWN function all the way down.
- (10) Pull the pan holder assembly outward until pan safety limit switch is no longer tripped. Depress SEAT UP footswitch and then SEAT DOWN footswitch.
- (11) Observe. The seat section of table top *should not* move when the SEAT UP and SEAT DOWN footswitches are depressed.
- (12) Push pan holder assembly inward until pan safety limit switch is tripped. Depress SEAT UP and SEAT DOWN footswitches.
- (13) Observe. The seat section of table top *should* move when the SEAT UP and SEAT DOWN footswitches are depressed.
- (14) Lower the SEAT DOWN function all the way down.
- (15) Depress and hold the BASE DOWN footswitch.
- (16) Observe. The BASE DOWN function should lower approximately 1/3 of its travel and then stop.
- (17) Raise the SEAT UP function all the way up.
- (18) Depress the BASE DOWN footswitch.
- (19) Observe. The BASE DOWN function should lower all the way down.
- (20) Pull the release handle and extend the foot extension. Then, pull the release handle and push the foot extension back into foot section.

## SECTION II TESTING AND TROUBLESHOOTING

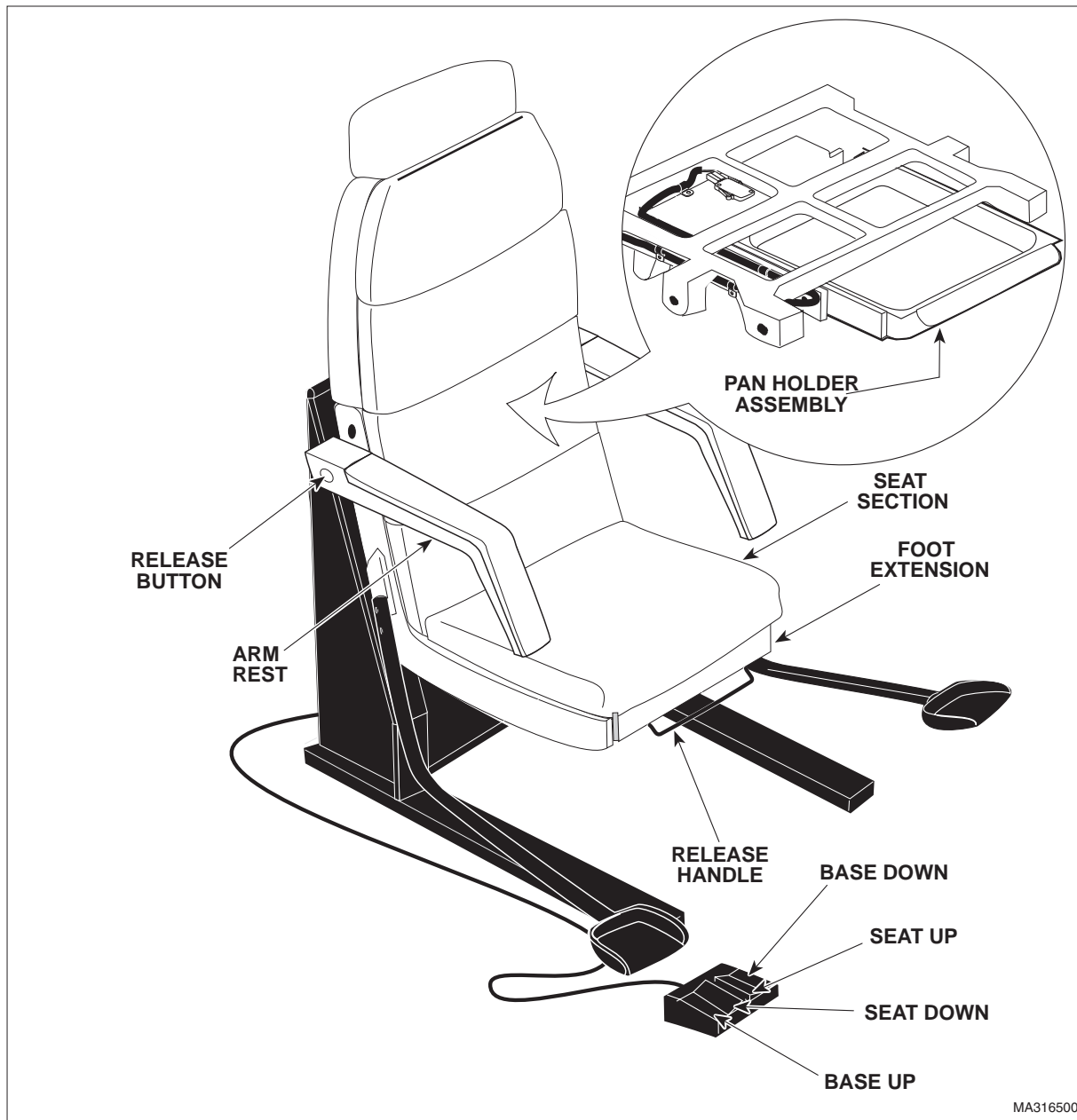

MA316500

**Figure 2-1. Operational Test**

- (21) Observe. The foot extension should slide out easily and quietly. The foot extension should automatically lock into a fully extended position. When the foot extension is pushed into the foot section, the foot extension should automatically lock into a stowed position.
- (22) Press the arm rest release button and lower the arm rest.
- (23) Observe. When the release button is pressed, the arm rest should be able to be lowered.
- (24) Raise arm rest upward and then release.
- (25) Observe. The arm rest should automatically lock into its normal position.

### 2.2 Troubleshooting Procedures

Table 2-1 is a Troubleshooting Guide which is used to determine the cause of the malfunction.

## SECTION II TESTING AND TROUBLESHOOTING

**Table 2-1. Troubleshooting Guide**

Problem	Symptom	Probable Cause	Check	Correction
Table will not operate when any of the Base or Seat up or down functions are selected.	When a foot control footswitch is depressed, its actuator motor does not run or hum.	Power cord is not plugged into facility wall outlet.	Check to see if power cord is plugged in.	Plug power cord into facility wall outlet.
		Facility circuit breaker providing power to chair is tripped.	Check to see if facility circuit breaker is tripped. One way of checking this is to plug a lamp into wall outlet that chair was plugged into.	If circuit breaker is tripped, determine what caused circuit breaker to trip, correct the problem, and then reset / replace circuit breaker.
		One or both fuses in AC connector receptacle is blown (export models only).	Refer to Figure 5-2, Sheets 1 or 2 for fuse information. Perform continuity check on fuse.	Replace any blown fuses.
		Wire connections loose.	Check all wiring connections from power cord to terminal block. Perform continuity check on wires. Use multimeter to check for proper voltage levels.	Clean any dirty connections. Tighten any loose connections. Replace any damaged connections.
SEAT UP function does not work, but SEAT DOWN function does.	When SEAT UP footswitch is depressed, nothing happens.	SEAT UP footswitch is malfunctioning.	Perform continuity check on SEAT UP footswitch. When footswitch is activated, there should be continuity between COM. and N.O. terminals of footswitch.	Replace SEAT UP footswitch. Refer to para 4.10.
		SEAT DOWN footswitch is sticking open.	Perform continuity check on SEAT DOWN footswitch. When footswitch is not activated, there should be continuity between COM. and N.C. terminals of footswitch.	Replace SEAT DOWN footswitch. Refer to para 4.10.
SEAT DOWN function does not work, but SEAT UP function does.	When SEAT DOWN footswitch is depressed, nothing happens.	SEAT DOWN footswitch is malfunctioning.	Perform continuity check on SEAT DOWN footswitch. When footswitch is activated, there should be continuity between COM. and N.O. terminals of footswitch.	Replace SEAT DOWN footswitch. Refer to para 4.10.
		Seat down limit switch is tripped.	Check if seat down limit switch is tripped. Seat down limit switch should be tripped when base actuator is in all the way down position to 2/3 up position. This prevents operator from accidentally colliding seat section with floor.	Raise BASE UP function until it is at least 2/3 of the way up in its travel. Then SEAT DOWN function will work. Inform operator of the seat down limit switch function.
		Seat down limit switch is malfunctioning.	Perform continuity check on N.C. seat down limit switch. Switch tripped = open circuit. Seat down	Replace seat down limit switch. Refer to para 4.9.

## SECTION II TESTING AND TROUBLESHOOTING

Table 2-1. Troubleshooting Guide - Continued

Problem	Symptom	Probable Cause	Check	Correction
SEAT UP and SEAT DOWN functions do not work.	When SEAT DOWN or SEAT UP footswitch is depressed, nothing happens.	Wire connections loose.	Check all wiring connections from SEAT DOWN footswitch to terminal block. Perform continuity check on wires. Use multimeter to check for proper voltage levels.	Clean any dirty connections. Tighten any loose connections. Replace any damaged connections.
		Treatment pan assembly is not pushed in all the way.	Check if treatment pan assembly is pushed all the way in to its stowed position.	Push treatment pan assembly all the way in. Inform operator on how this function works.
		Pan safety limit switch is malfunctioning.	Perform continuity check on pan safety limit switch. Switch tripped = closed circuit or continuity.	Replace pan safety limit switch. Refer to para 4.4.
		Seat capacitor is weak or blown.	Replace suspect seat capacitor with known working seat capacitor.	Replace seat capacitor. Refer to para 4.7.
		Thermal overload switch in seat actuator motor is activated.	—	Wait 10 to 20 minutes to allow seat actuator motor to cool.
		Seat actuator assembly is malfunctioning.	Replace suspect seat actuator assembly with known working seat actuator assembly.	Replace seat actuator assembly. Refer to para 4.3.
BASE DOWN function does not work, but BASE UP function does.	When BASE DOWN footswitch is depressed, nothing happens.	BASE DOWN footswitch is malfunctioning.	Perform continuity check on BASE DOWN footswitch. When footswitch is activated, there should be continuity between COM. and N.O. terminals of footswitch.	Replace BASE DOWN footswitch. Refer to para 4.10.
		BASE UP footswitch is sticking open.	Perform continuity check on BASE UP footswitch. When footswitch is not activated, there should be continuity between COM. and N.C. terminals of footswitch.	Replace BASE UP footswitch. Refer to para 4.10.
		Base down limit switch is tripped.	Check if base down limit switch is tripped. Base down limit switch will be tripped when base actuator is lowered below the 2/3 up position. This removes current from base actuator if N.C seat up limit switch is also tripped. This prevents operator from accidentally colliding seat section with floor.	Raise SEAT UP function all the way up to untrip seat up limit switch. Then BASE DOWN function can be lowered all the way down. Inform the operator how this function works.

## SECTION II TESTING AND TROUBLESHOOTING

**Table 2-1. Troubleshooting Guide - Continued**

Problem	Symptom	Probable Cause	Check	Correction
BASE DOWN function does not work, but BASE UP function does - Continued.	When BASE DOWN footswitch is depressed, nothing happens - Continued.	Base down limit switch is malfunctioning.	Perform continuity check on N.C. base down limit switch. Switch tripped = open circuit. Base down limit switch is tripped when base actuator is in all the way down position to 2/3 up position.	Replace base down limit switch. Refer to para 4.9.
		Seat up limit switch is malfunctioning.	Perform continuity check on N.C. seat up limit switch. Switch tripped = open circuit. Seat up limit switch is untripped only when seat section is all the way up.	Replace seat up limit switch. Refer to para 4.2.
BASE UP function does not work, but BASE DOWN function does.	When BASE UP footswitch is depressed, nothing happens.	BASE UP footswitch is malfunctioning.	Perform continuity check on BASE UP footswitch. When footswitch is activated, there should be continuity between COM. and N.O. terminals of footswitch.	Replace BASE UP footswitch. Refer to para 4.10.
		Gas spring is malfunctioning.	Replace suspect gas spring with known working gas spring.	Replace gas spring. Refer to para 4.5.
BASE UP and BASE DOWN functions do not work.	When BASE UP or BASE DOWN footswitch is depressed, nothing happens.	Wire connections loose.	Check all wiring connections from BASE UP footswitch to terminal block. Perform continuity check on wires. Use multimeter to check for proper voltage levels.	Clean any dirty connections. Tighten any loose connections. Replace any damaged connections.
		Base capacitor is weak or blown.	Replace suspect base capacitor with known working base capacitor.	Replace base capacitor. Refer to para 4.7.
		Thermal overload switch in base actuator motor is activated.	-	Wait 10 to 20 minutes to allow base actuator motor to cool.
		Base actuator assembly is malfunctioning.	Replace suspect base actuator assembly with known working base actuator assembly.	Replace base actuator assembly. Refer to para 4.6.

## SECTION II TESTING AND TROUBLESHOOTING

Table 2-1. Troubleshooting Guide - Continued

Problem	Symptom	Probable Cause	Check	Correction
Chair moves fine for light patient, but will not move or moves slowly for very heavy patient.	Heavy patients cause table to malfunction.	Low voltage is being supplied to chair.	Check voltage at wall receptacle - should be 115 +/- 5 VAC for domestic units and 230 +/- 10 VAC for export units.	Correct low voltage situation at wall receptacle.
		Table overloaded with too heavy of a patient.	Maximum weight capacity of table is 300 lbs (136.0 kg).	Inform chair operator of weight limitation.
		Capacitor for suspect function is weak.	Replace suspect capacitor with known working capacitor.	Replace capacitor. Refer to para 4.7.
Whirling or squeaking noise is heard when an actuator assembly is being run.	Noisy actuator.	Foreign matter on ball screw threads and / or lack of lubricant.	Check for foreign matter on ball screw threads. Check for lack of lubricant on ball screw threads.	Clean all foreign matter off of ball screw threads. Coat ball screw threads with STP treatment oil or equivalent. If actuator assembly is still noisy, replace. Refer to para 4.3 or 4.6.
Foot extension locking mechanism is malfunctioning.	Foot extension does not lock into stowed position or extended position automatically.	Foot extension lock / unlock mechanism is malfunctioning.	Check to see if return spring is present. Check to see if linking rod is present.	Lubricate mechanism with a silicone based lubricant. Replace missing, worn, or broken return spring or linking rod.



**SECTION III  
SCHEDULED MAINTENANCE**

**3.1 Scheduled Maintenance**

periodically on the chair. These inspections and services should be performed as often as indicated in the chart.

Table 3-1 is a Scheduled Maintenance Chart which lists the inspections and services that should be performed

**Table 3-1. Scheduled Maintenance Chart**

Interval	Inspection or Service	What to Do
Semi-annually	Obvious damage	Visually check condition of chair for obvious damage such as: cracks in components, missing components, dents in components, or any other visible damage which would cause chair to be unsafe to operate or would compromise its performance. Repair chair as necessary.
	Fasteners/hardware	Check chair for missing or loose fasteners / hardware. Replace any missing hardware and tighten any loose hardware as necessary.
	Warning and instructional decals	Check for missing or illegible decals. Replace decals as necessary.
	Pivot points / moving parts / accessories	Lubricate all exposed pivot points, moving parts, and accessories with silicone based lubricant.
	Foot control	Check that foot control works correctly. Make sure all footswitches operate properly. Replace any malfunctioning footswitches. Refer to para 4.10.
	Ball screws of actuator assemblies	Extend each actuator assembly and wipe ball screw threads down with a rag to remove foreign matter. Coat as much of the ball screw threads as possible with STP treatment oil or equivalent. Run each actuator assembly to both ends of its travel a couple of times to spread the oil evenly over all of the ball screw threads and then remove excess oil. If oil does not correct a squealing actuator assembly, replace actuator assembly. Refer to para 4.3 or 4.6.
	Inner tube of base actuator	Lubricate inner tube of base actuator with vaseline.
	Drifting of actuator assemblies	Check each actuator assembly for drift. Replace actuator assembly brake components as necessary. Refer to para 4.8.
	Foot extension	Check that foot extension automatically locks into stowed and extended positions. Lubricate linkages with a silicone based lubricant.
	Pan safety limit switch	Check that pan safety limit switch is tripped when pan assembly is in fully stowed position. Adjust or replace pan safety limit switch if necessary. Refer to para 4.4.
	Electrical receptacle (domestic units only)	Check that the electrical receptacle is functioning properly. Replace receptacle as necessary.
	Upholstery	Check all upholstery for rips, tears, or excessive wear. Replace cushions as necessary.
	Accessories	Check that all accessories have all of their components and that they function properly. If necessary, repair or replace the accessory.
Operational Test	Perform an Operational Test to determine if the chair is operating within its specifications (Refer to para 3.1). Replace or adjust any malfunctioning components.	



**SECTION IV  
MAINTENANCE / SERVICE INSTRUCTIONS**

**4.1 Introduction**

**DANGER**  
Refer to the Operator Manual for complete instructions on operating the chair. Failure to do so could result in personal injury.

**NOTE**  
Perform an operational test on the chair after the repair is completed to confirm the repair was properly made and that *all* malfunctions were repaired.

The following paragraphs contain removal, installation, repair, and adjustment procedures for the chair.

**4.2 Seat Up Limit Switch Removal / Installation**

**A. Removal**

- (1) Raise TABLE UP and SEAT UP functions all the way up.

**DANGER**  
Always disconnect the power cord from the wall outlet before removing any of the chair's covers/shrouds or making any repairs to prevent the possibility of electrical shock. Failure to comply with these instructions could result in severe personal injury or death.

- (2) Unplug chair power cord from wall outlet.
- (3) Cut two cable ties and remove actuator sleeve (1, Figure 4-1) from shaft of seat actuator (2).
- (4) On early units, tag and disconnect two wires (3A) from terminals of seat up limit switch (4). On later units, disconnect wire harness (3B) from seat up limit switch (4).
- (5) Remove two nuts (5), screws (6), and seat up limit switch (4) from switch bracket (7).

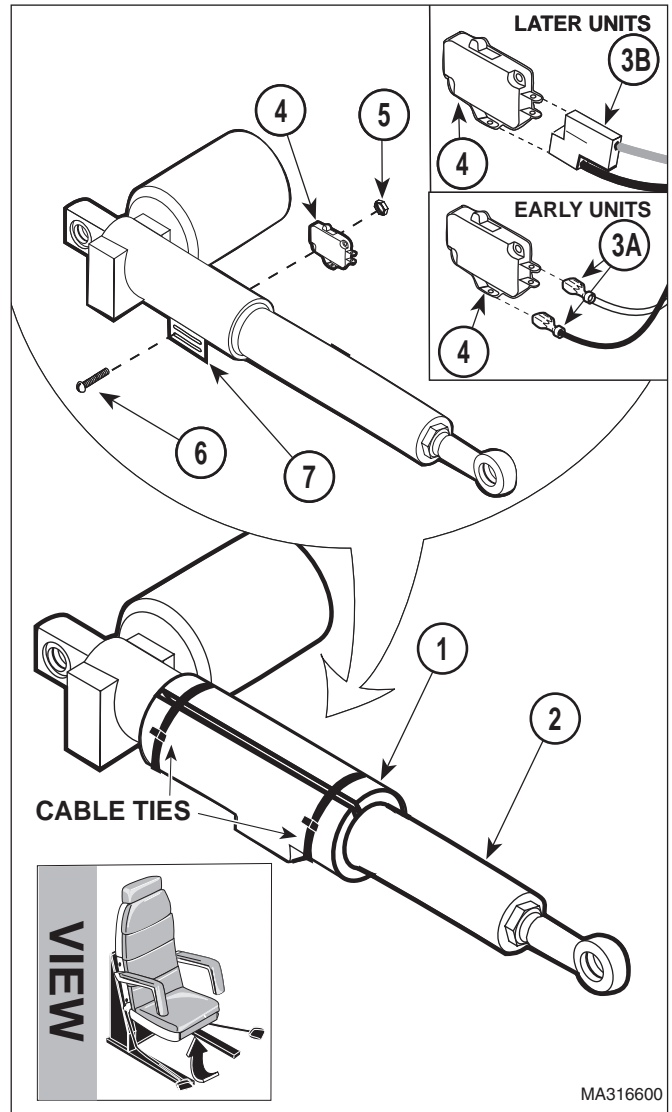

**Figure 4-1. Seat Up Limit Switch Removal / Installation**

**B. Installation**

**NOTE**  
With SEAT UP function all the way up, seat up limit switch should be untripped. Make sure seat up limit switch is installed to meet this condition.

- (1) Install seat up limit switch (4) on switch bracket (7) and secure with two screws (6) and nuts (5), making sure trip arm of switch is in cutout of seat actuator shaft (2).

## SECTION IV MAINTENANCE / SERVICE

- (2) On early units, connect two wires (3A) to terminals of seat up limit switch (4).  
On later units, connect wire harness (3B) to seat up limit switch (4).
- (3) Install actuator sleeve (1) on shaft of seat actuator (2) and secure with two cable ties.
- (4) Plug chair power cord into wall outlet.

### 4.3 Seat Actuator Removal / Installation

#### A. Removal

- (1) If possible, raise SEAT UP function all the way up.



#### **DANGER**

**Always disconnect the power cord from the wall outlet before removing any of the chair's covers/shrouds or making any repairs to prevent the possibility of electrical shock. Failure to comply with these instructions could result in severe personal injury or death.**

- (2) Unplug chair power cord from wall outlet.
- (3) Remove two cable ties and remove actuator sleeve (1, Figure 4-2) from shaft of seat actuator (2).
- (4) On early units, tag and disconnect two wires (3A) from terminals of seat up limit switch (4).  
On later units, disconnect wire harness (3B) from seat up limit switch (4).
- (5) Remove two screws (5), lockwashers (6), and seat up limit switch assembly (4) from shaft of seat actuator (2).

#### **NOTE**

Early units are units with Serial Numbers BK-1000 thru BK1271 and V-1000 thru V-1575. Later units are units with Serial Numbers BK-1272, V-1576, and FH-1000 thru Present.

- (6) On early units, tag and disconnect three wires (7A) from three actuator wires (8A).  
On later units, disconnect wire harness (7B) from connector receptacle (8B).

#### **NOTE**

The following step applies to later units only.

- (7) On later units, remove two screws (9) and partially separate receptacle bracket (10) from pivot frame (11).
- (8) Cut any cable ties securing wire / wire harnesses to seat actuator (2).
- (9) While supporting seat section (1, Figure 4-3), remove two e-rings (2), clevis pin (3), and base of seat actuator (4) from bracket (5).
- (10) While supporting seat section (1), remove two e-rings (6), spacers (7), clevis pin (8), and seat actuator (4) from bracket (9). Remove seat actuator from chair.

#### B. Installation

#### **NOTE**

This jam nut has left hand threads.

- (1) Loosen jam nut (10, Figure 4-3); then remove swivel joint (11) from shaft of new seat actuator (4).
- (2) Coat threads of swivel joint (11) with permanent threadlocking adhesive (Loctite 262).
- (3) Screw swivel joint (11) into shaft of seat actuator (4).
- (4) While supporting seat section (1), install base of seat actuator (4) on bracket (5) and secure with clevis pin (3) and two e-rings (2).
- (5) While supporting seat section (1), install shaft end of seat actuator (4) on bracket (9) and secure temporarily with clevis pin (8).

#### **NOTE**

The following step applies to later units only.

- (6) On later units, install receptacle bracket (10, Figure 4-2) on pivot frame (11) and secure with two screws (9).

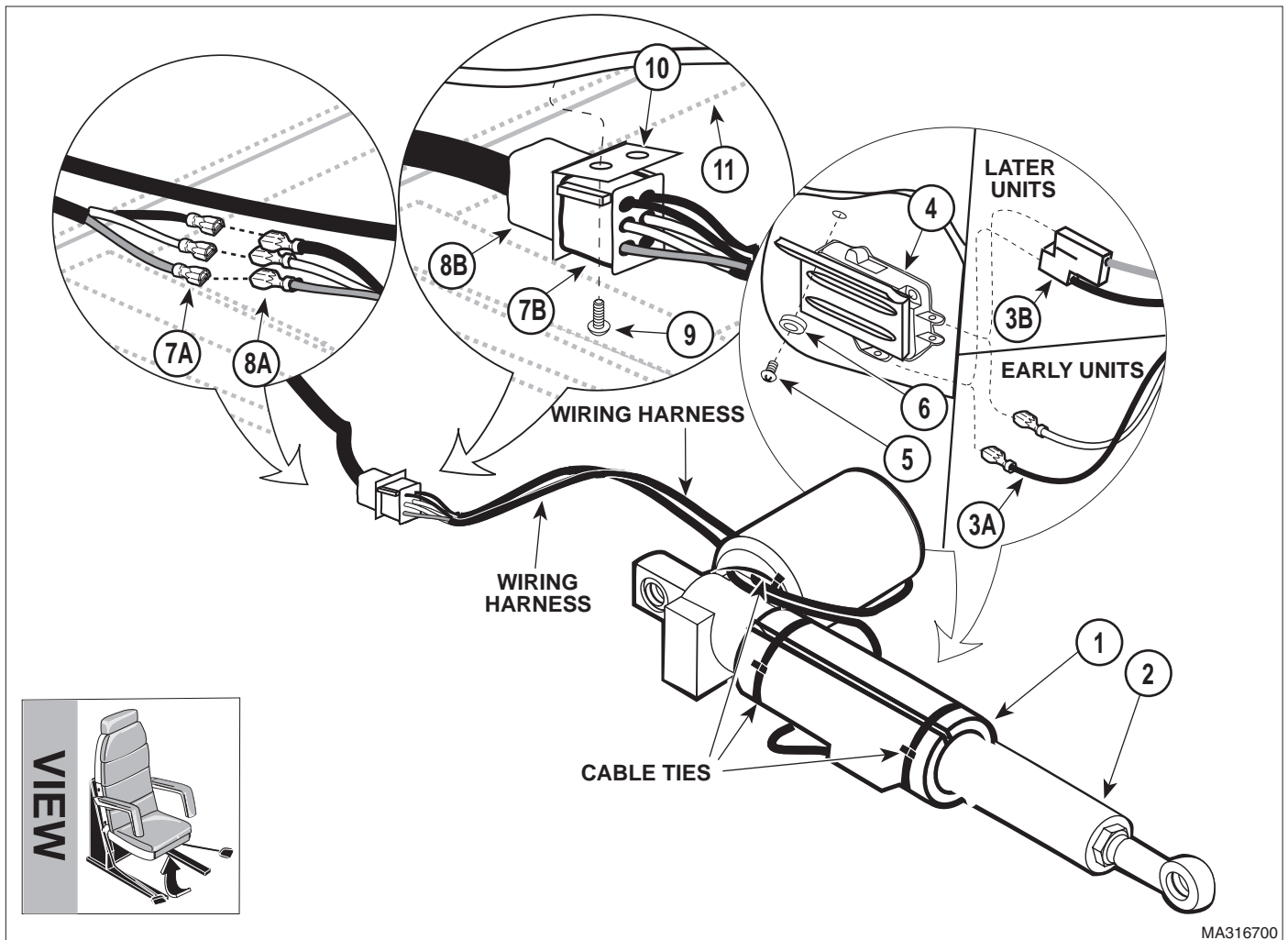

MA316700

**Figure 4-2. Seat Actuator Wires Disconnection / Connection**

- (7) On early units, connect three wires (7A) to three actuator wires (8A).  
On later units, connect wire harness (7B) to connector receptacle (8B).
- (8) Install switch bracket assembly (4) on shaft of seat actuator (2) and secure with two lockwashers (6) and screws (5).
- (9) On early units, connect two wires (3A) to terminals of seat up limit switch (4).  
On later units, connect wire harness (3B) to seat up limit switch (4).
- (10) Secure wires / wire harnesses to seat actuator (2) with a cable tie.
- (11) Install actuator sleeve (1) on shaft of seat actuator (2) and secure with two cable ties.
- (12) Run SEAT UP function all the way up and then run TABLE DOWN function all the way down.
- (13) If seat section (1, Figure 4-3) *is* level with floor, go to step 18. If seat section (1) *is not* level with floor, go to step 14.
- (14) While supporting seat section (1), remove clevis pin (8) securing swivel joint (11) of seat actuator (4) to bracket (9).
- (15) Screw swivel joint (11) in or out as determined necessary in step 13.

## SECTION IV MAINTENANCE / SERVICE

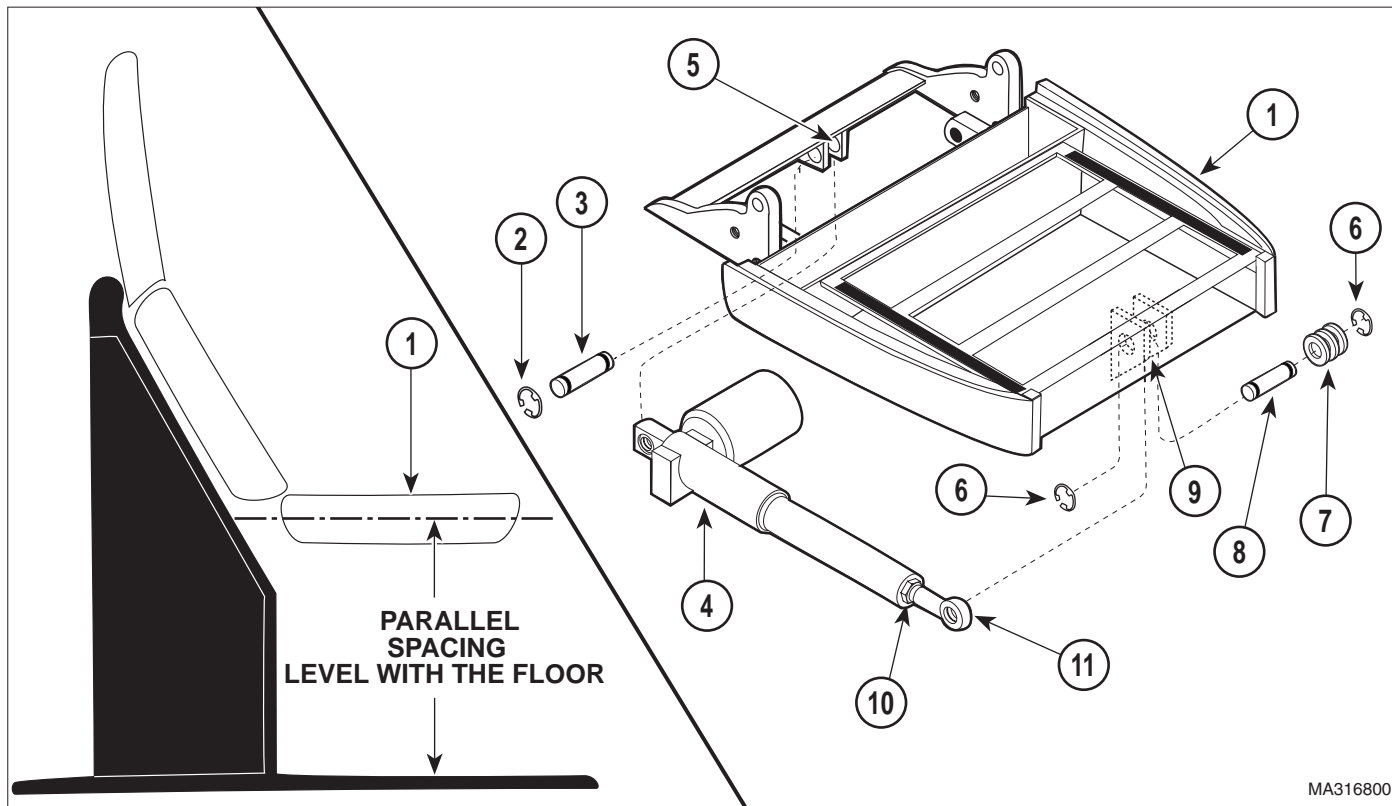

Figure 4-3. Seat Actuator Removal / Installation

MA316800

- (16) Connect swivel joint (11) of seat actuator (4) to bracket (9) and secure with clevis pin (8).
- (17) Repeat steps 12 thru 16 until seat section (1) is level with floor.
- (18) Install spacers (7) and two e-rings (6) on clevis pin (8).
- (19) Tighten jam nut (10).
- (20) Plug chair power cord into wall outlet.

### 4.4 Pan Safety Limit Switch Removal / Installation

#### A. Removal

- (1) If possible, run seat section all the way down.



#### DANGER

Always disconnect the power cord from the wall outlet before removing any of the chair's covers/shrouds or making any repairs to prevent the possibility of electrical shock. Failure to comply with these instructions could result in severe personal injury or death.

- (2) Unplug chair power cord from wall outlet.

#### NOTE

The upholstered lower back section is held onto the lower back casting with velcro.

- (3) Remove upholstered lower back section (1, Figure 4-4) from lower back casting (2).
- (4) Pull pan holder assembly (3) out as far as possible.

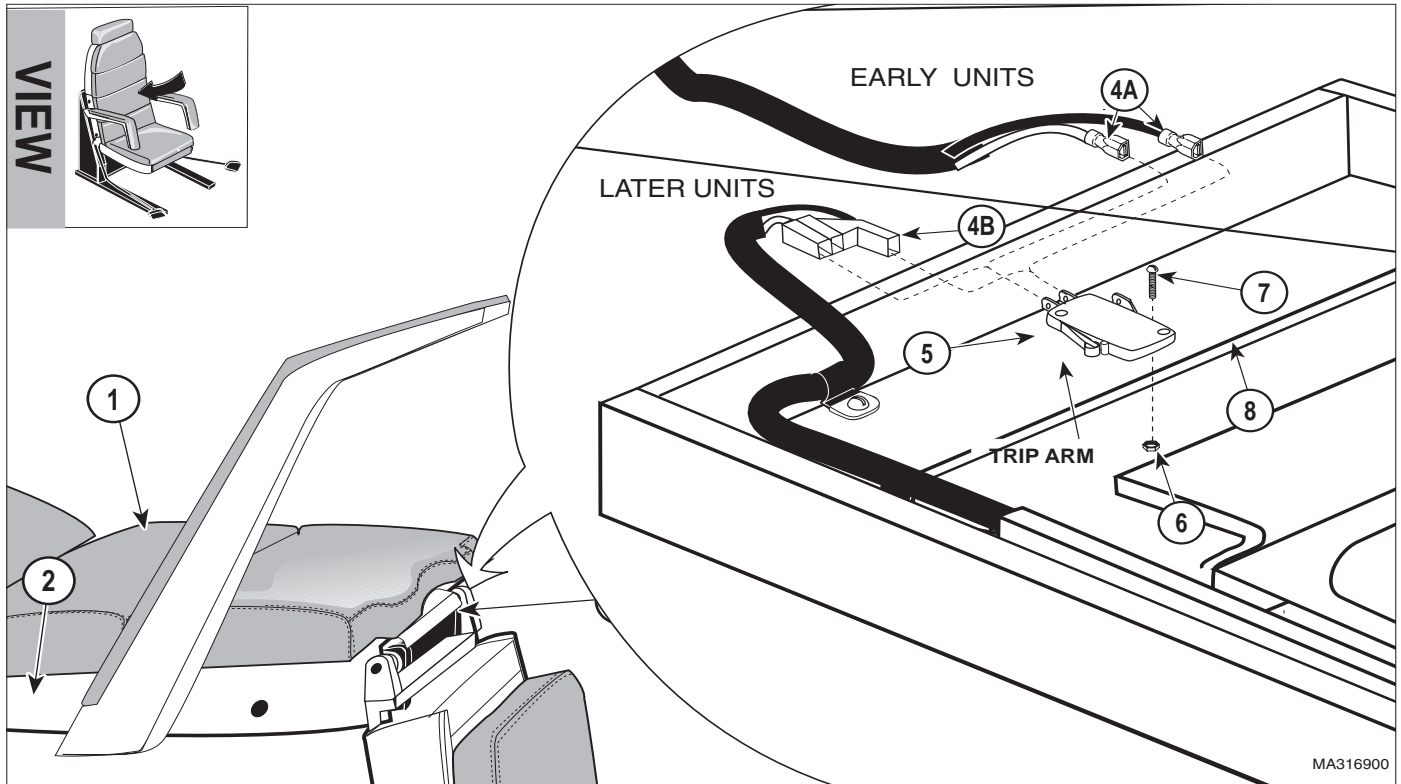

**Figure 4-4. Pan Safety Limit Switch Removal / Installation**

**NOTE**

Early units are units with Serial Numbers BK-1000 thru BK1271 and V-1000 thru V-1575. Later units are units with Serial Numbers BK-1272, V-1576, and FH-1000 thru Present.

- (5) On early units, tag and disconnect two wires (4A) from pan safety limit switch (5).  
On later units, disconnect wire harness (4B) from pan safety limit switch (5).
  - (6) Remove two nuts (6), screws (7), and pan safety limit switch (5) from pan frame (8).
- B. Installation**
- (1) Install pan safety limit switch (5) on pan frame (8) and secure with two screws (7) and nuts (6). Do not tighten nuts at this time.
  - (2) On early units, connect one wire (4A) to N.O. terminal and other wire (4A) to COM. terminal of pan safety limit switch (5).  
On later units, connect wire harness (4B) to pan safety limit switch (5).
  - (3) Push pan holder assembly (3) all the way in until it locks into its fully stowed position, while observing, from under lower back casting (2), how the pan safety limit switch (5) is being tripped.
  - (4) Slide pan safety limit switch (5) inward or outward as determined necessary, so that the trip arm of pan safety limit switch is tripped just before the pan holder assembly (3) locks into its fully stowed position.
  - (5) Repeat steps 3 and 4 until the pan safety limit switch (5) is positioned properly. Then secure the pan safety limit switch (5) in position by tightening two nuts (6).
  - (6) Install upholstered lower back section (1) on lower back casting (2).
  - (7) Plug chair power cord into wall outlet.

## SECTION IV MAINTENANCE / SERVICE

### 4.5 Gas Spring Removal / Installation

#### A. Removal

- (1) If possible, raise TABLE UP and SEAT UP functions all the way up.



#### WARNING

Always disconnect the power cord from the wall outlet before removing any of the table's covers / shrouds or making any repairs to prevent the possibility of electrical shock. Failure to comply with these instructions could result in severe personal injury or death.

- (2) Unplug chair power cord from wall outlet.
- (3) Remove seven screws (1, Figure 4-5), outer shroud (2), and inner shroud (3) from base casting (4).



#### WARNING

If TABLE UP function is not all the way up, the gas spring will be under extreme pressure. Raise table all the way up before removing gas spring mounting hardware. Failure to do so could result in serious personal injury or death.

- (4) Remove two screws (5), four washers (6), and gas spring (7) from brackets (8).

#### B. Installation

- (1) Coat threads of two screws (5) with removable threadlocking adhesive (Loctite 242).
- (2) Install gas spring (7) on brackets (8) and secure with four washers (6) and two screws (5).
- (3) Install inner shroud (3) and outer shroud (2) on base casting (4) and secure with seven screws (1).
- (4) Plug chair power cord into wall outlet.

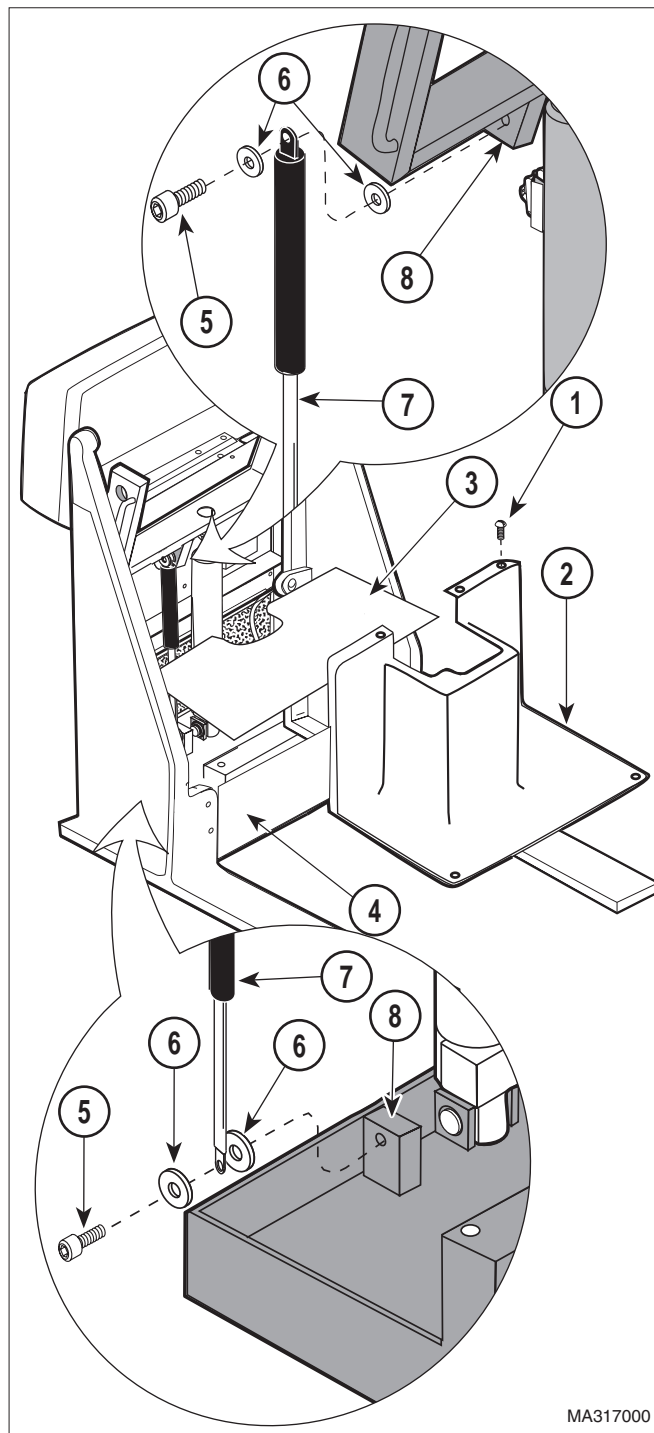



Figure 4-5. Gas Spring Removal / Installation



**4.6 Base Actuator Removal / Installation**

**A. Removal**

- (1) Remove gas spring (Refer to para 4.5).
- (2) Remove stirrup from patient's right side of chair.

**WARNING**  

**Chair is heavy. Use proper lifting techniques (and an assistant if necessary) to raise and lower chair. Failure to do so could result in back injury.**

- (3) Lay chair onto its right side (patients).
- (4) Remove two screws (1, Figure 4-6) and gas spring base mounting bracket (2) from base casting (3).
- (5) Remove two screws (4), lockwashers (5), and switch bracket assembly (6) from shaft of base actuator (7).
- (6) Cut cable ties securing wires to base actuator (7).
- (7) Remove screw (8) and two cable clamps (9) from base casting (3). Remove cable clamp (9) off of base actuator cable (10).
- (8) Tag three actuator wires (11); then loosen three terminal screws (12) and disconnect three actuator wires (11) from terminal block (13).

**NOTE**  
 Access to jam nut (1) may only be possible with a "homemade" ground down 1-1/8 in. open end wrench.

- (9) Loosen jam nut (1, Figure 4-7).

**NOTE**  
 Setscrews are only on later units. Open rear access door to gain access to the rear setscrew.

- (10) If present, loosen two setscrews (2).

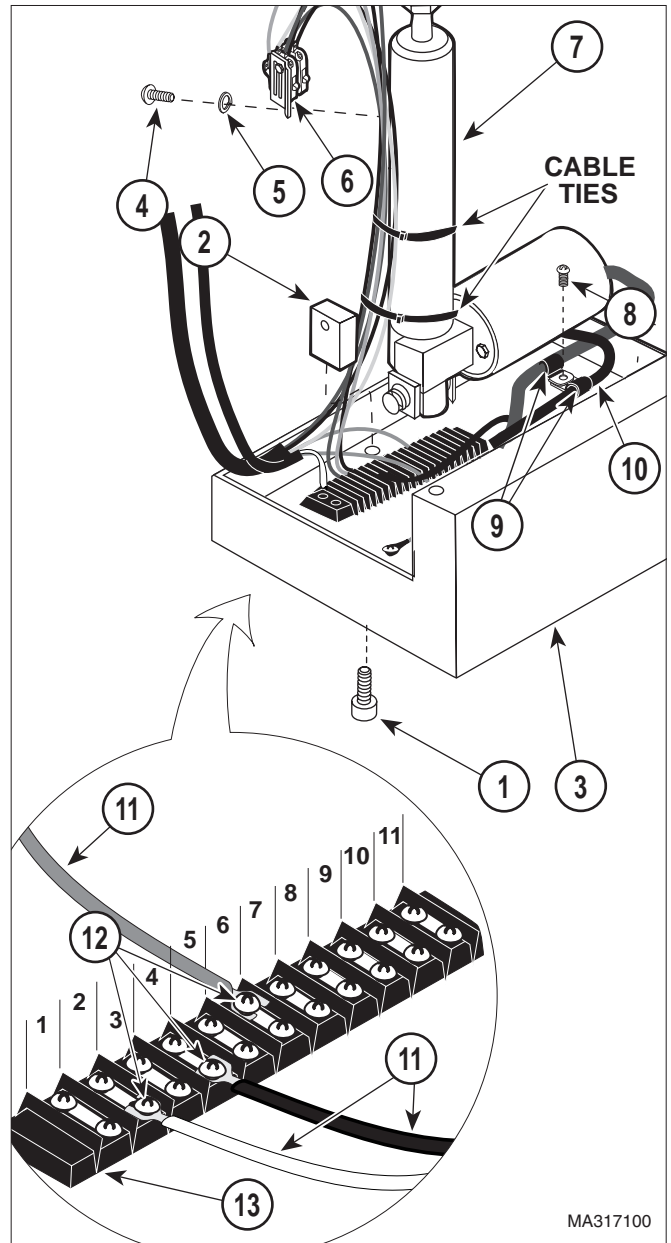

**Figure 4-6. Wires Disconnection / Connection**

- (11) Remove screw (3), six screws (4), and back cover (5) from side uprights (6).
- (12) While supporting seat section (7), remove two e-rings (8) and clevis pin (9) securing base of base actuator (10) to bracket (11).

## SECTION IV MAINTENANCE / SERVICE

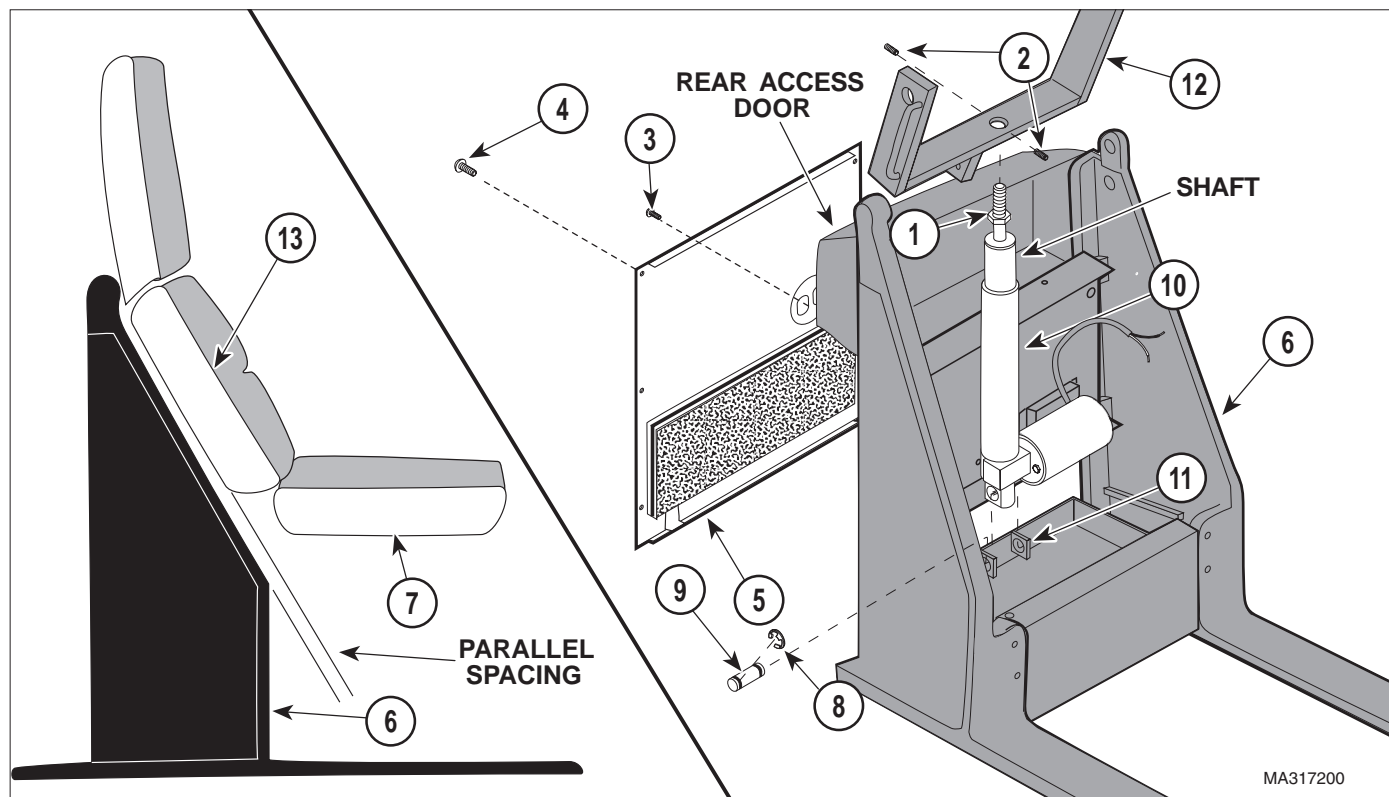

Figure 4-7. Base Actuator Removal / Installation

### NOTE

Note how far threads of base actuator are screwed into chair yoke frame.

- (13) While supporting seat section (7), use strap wrench or channel lock pliers with a soft cloth to unscrew shaft of base actuator (10) from chair yoke frame (12).

### B. Installation

- (1) Screw jam nut (1, Figure 4-7) onto threads of base actuator (10) fully.
- (2) If unit does not have two setscrews (2), apply permanent threadlocking adhesive (Loctite 262) to threads of base actuator (10).
- (3) While supporting seat section (7), screw new base actuator (10) into chair yoke frame (12) approximately the same distance as old base actuator used to be.
- (4) While supporting seat section (7), connect base actuator (10) to bracket (11) with clevis pin (9) and two e-rings (8).
- (5) Connect three actuator wires (11, Figure 4-6) to terminal block (13) and secure by tightening three terminal screws (12).
- (6) Install one cable clamp (9) onto base actuator cable (10); then secure both cable clamps (9) to base casting (3) with screw (8).
- (7) Install switch bracket (6) on shaft of base actuator (7) and secure with two lockwashers (5) and screws (4).
- (8) Secure wires to base actuator (7) with three cable ties.
- (9) Raise chair to upright position.

- (10) Plug chair power cord into wall outlet.
- (11) Run SEAT UP function all the way up and TABLE DOWN function all the way down.
- (12) If lower back casting (13, Figure 4-7) *is* parallel with angled surface of side upright (6), go to step 16.  
If lower back casting (13) *is not* parallel with angled surface of side upright (6), go to step 13.
- (13) Using strap wrench or channel lock pliers with a soft cloth, screw shaft of base actuator (10) in or out of chair yoke frame (12) as determined necessary in step 12.
- (14) Repeat steps 11 thru 13 until lower back casting (13) *is* parallel with angled surface of side upright (6) when chair is in full TABLE DOWN position.
- (15) Tighten jam nut (1).

**NOTE**

Setscrews are only on later units. Open rear access door to gain access to the rear setscrew.

- (16) If present, tighten two setscrews (2).
- (17) Install back cover (5) on side uprights (6) and secure with six screws (4) and one screw (3).



**WARNING**

**Chair is heavy. Use proper lifting techniques (and an assistant if necessary) to raise and lower chair. Failure to do so could result in back injury.**

- (18) Lay chair onto its side.
- (19) Install gas spring base mounting bracket (2, Figure 4-6) on base casting (3) and secure with two screws (1).
- (20) Raise chair to upright position.
- (21) Install gas spring (Refer to para 4.5).
- (22) Install stirrup.

## 4.7 Typical Capacitor Removal / Installation

### A. Removal

- (1) If possible, raise TABLE UP and SEAT UP function all the way up.



**WARNING**

**Always disconnect the power cord from the wall outlet before removing any of the table's covers / shrouds or making any repairs to prevent the possibility of electrical shock. Failure to comply with these instructions could result in severe personal injury or death.**

- (2) Unplug chair power cord from wall outlet.
- (3) Remove seven screws (1, Figure 4-8), outer shroud (2), and inner shroud (3) from base casting (4).
- (4) Using a screwdriver, pry tab of capacitor mounting bracket (5) outward and remove capacitor (6) from capacitor mounting bracket.
- (5) Remove capacitor cap (7) from capacitor (6).



**WARNING**

**A capacitor contains stored electricity. Never touch terminals of a capacitor, even if power has been shut off or disconnected. Always discharge capacitor before touching capacitor terminals or wires. Failure to comply with these instruction could result in serious personal injury or death.**

- (6) Discharge capacitor (6).
- (7) Disconnect two wires (8) from terminals of capacitor (6).

### B. Installation

- (1) Connect two wires (8) to terminals of capacitor (6).
- (2) Install capacitor cap (7) on capacitor (6).

## SECTION IV MAINTENANCE / SERVICE

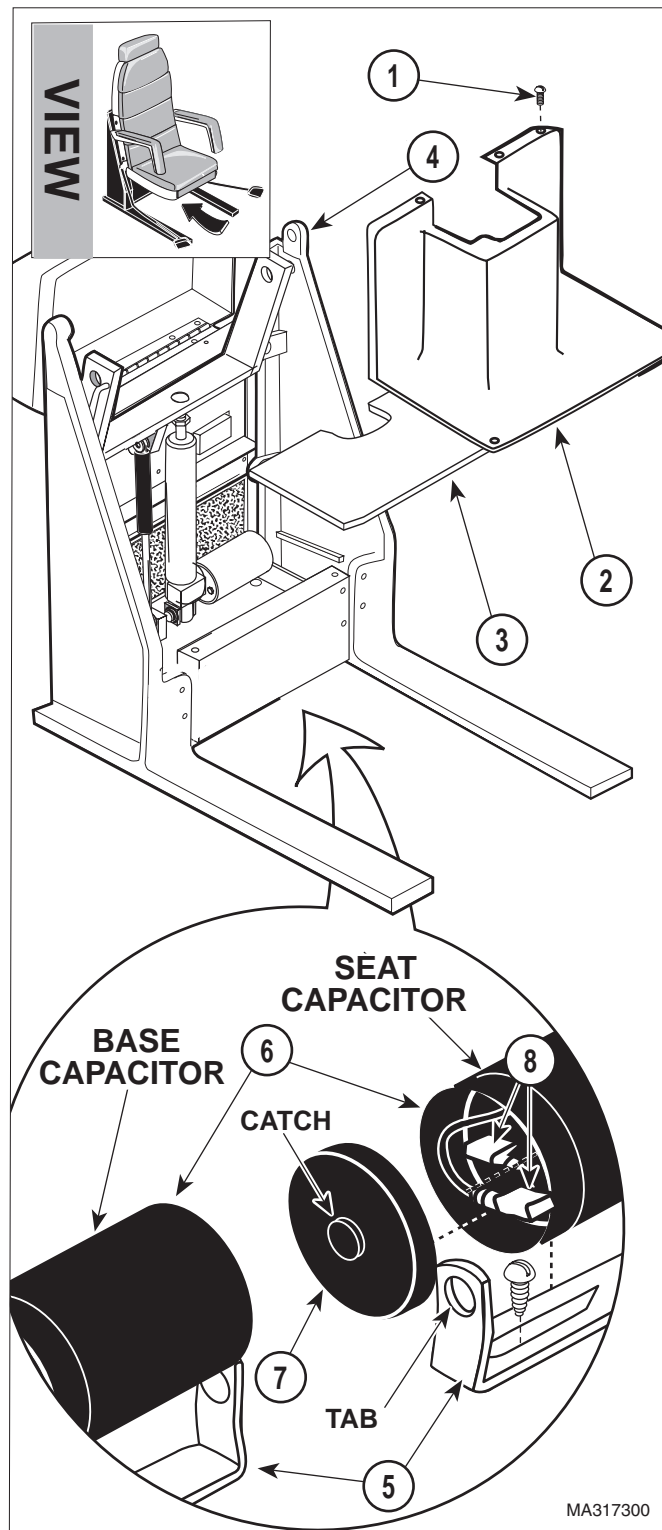

Figure 4-8. Typical Capacitor Removal / Installation

- (3) Position bottom of capacitor (6) on capacitor mounting bracket (5) and then push the top of the capacitor in. Using a screwdriver, force tab of capacitor mounting bracket (5) down over catch.
- (4) Install inner shroud (3) and outer shroud (2) on base casting (4) and secure with seven screws (1).
- (5) Plug chair power cord into wall outlet.

### 4.8 Typical Actuator Motor / Actuator Brake Removal / Installation

#### A. Removal

- (1) Remove malfunctioning actuator assembly: Seat actuator assembly (Refer to para 4.3). Base actuator assembly (Refer to para 4.6).
- (2) Remove two nuts (1, Figure 4-9) and actuator motor (2) from actuator mechanism (3).
- (3) Remove two shoulder washers (4) from actuator mechanism (3).
- (4) Remove spacer (5) and motor coupler (6) from shaft of actuator motor (2).

#### NOTE

A needle nose pliers should be used to extract the actuator brake from the actuator mechanism. Grasp the raised round plate of the actuator brake with the pliers and pull.

- (5) Remove actuator brake (7) and rubber damper (8) from shaft of actuator mechanism (3).

#### B. Installation

#### NOTE

The rubber damper must be installed so its flat side faces the inside of the actuator mechanism. The actuator brake must be installed so its flattest side faces outward. The shaft of the actuator mechanism may be turned with a screwdriver to help align the keys of the actuator mechanism shaft with the key slots in actuator brake.

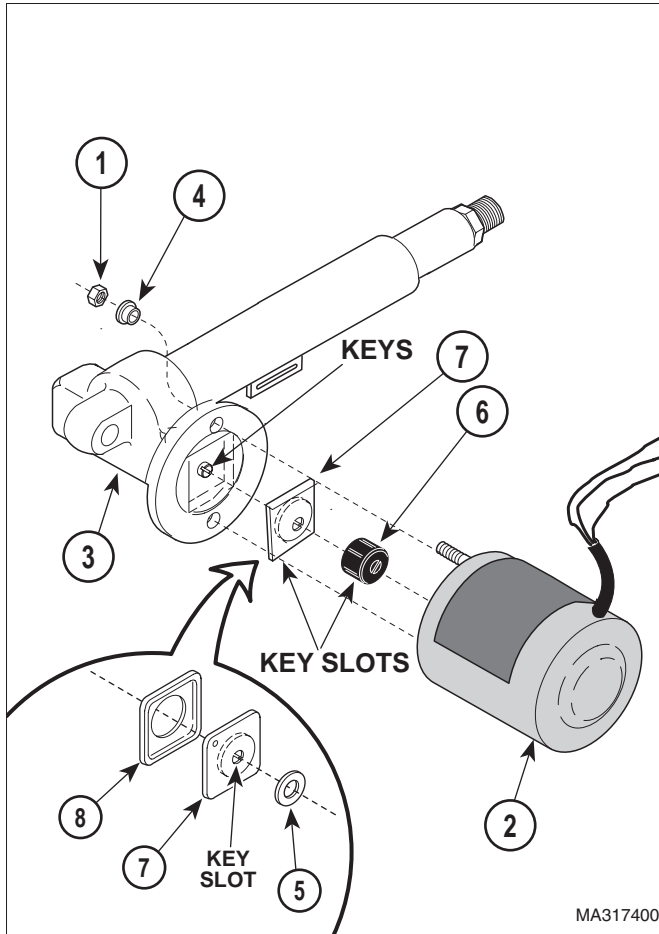

**Figure 4-9. Typical Actuator Motor / Actuator Brake Removal / Installation**

- (1) Install rubber damper (8), actuator brake (7), and spacer (5) in actuator mechanism (3).
- (2) Install motor coupler (6) on shaft of actuator motor (2).
- (3) Install two shoulder washers (4) in actuator mechanism (3).
- (4) Align keys of actuator mechanism (3) shaft with key slots of motor coupler (6) and then install actuator motor (2) on actuator mechanism (3) and secure with two nuts (1).
- (5) Install actuator assembly:  
Base actuator assembly (Refer to para 4.6).  
Seat actuator assembly (Refer to para 4.3).

- (6) Check actuator assembly for proper operation. The actuator assembly should run normally and should not make a grinding noise. A grinding noise indicates that key slots of motor coupler were not aligned properly with keys of actuator mechanism (a grinding noise also indicates that the motor coupler is being damaged). The actuator assembly should brake properly.

#### **4.9 Base Down Limit Switch or Seat Down Limit Switch Removal / Installation**

##### **A. Removal**

- (1) If possible, raise TABLE UP and SEAT UP functions all the way up.



#### **WARNING**

**Always disconnect the power cord from the wall outlet before removing any of the table's covers / shrouds or making any repairs to prevent the possibility of electrical shock. Failure to comply with these instructions could result in severe personal injury or death.**

- (2) Unplug chair power cord from wall outlet.
- (3) Remove seven screws (1, Figure 4-10), outer shroud (2), and inner shroud (3) from base casting (4).
- (4) Remove two screws (5), lockwashers (6), and switch bracket (7) from shaft of base actuator (8).
- (5) Tag and disconnect two wires (1, Figure 4-11) from base down limit switch (2).
- (6) Tag and disconnect two wires (3) from seat down limit switch (4).

#### **NOTE**

Note or mark the approximate position of the limit switches on the switch bracket. This will help during installation.

- (7) Remove two nuts (5), lockwashers (6), screws (7), and limit switches (2 and 4) from switch bracket (8).

## SECTION IV MAINTENANCE / SERVICE

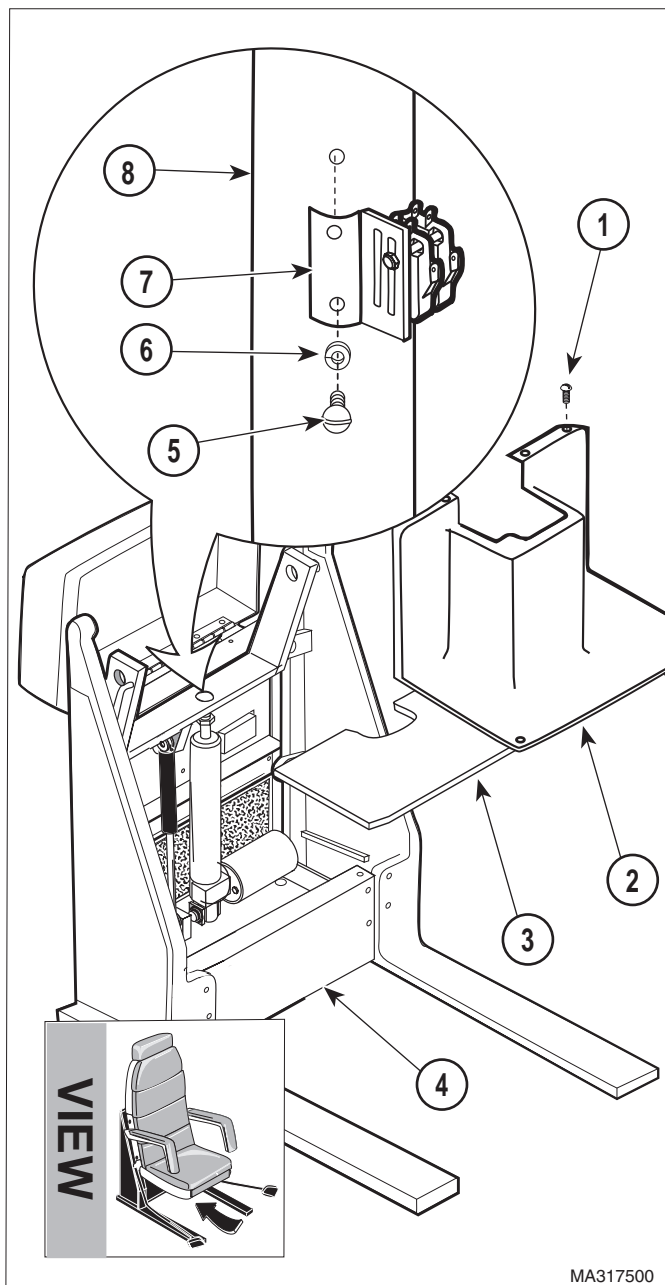

**Figure 4-10. Base Down Limit Switch or Seat Down Limit Switch Removal / Installation**

### B. Installation

- (1) Install limit switches (2 and 4, Figure 4-11) on switch bracket (8) and secure with two screws (7), lockwashers (6), and nuts (5), making sure to position the limit switches in approximately same position as they were removed.

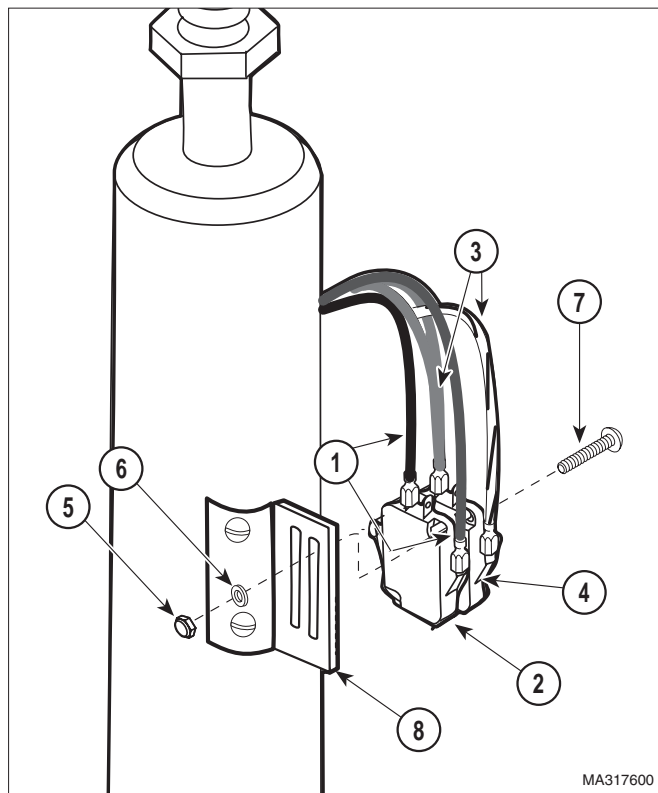

**Figure 4-11. Wires Disconnection / Connection**

- (2) Connect one wire (3) to N.C. terminal and the other wire (3) to COM. terminal of seat down limit switch (4).
- (3) Connect one wire (1) to N.C. terminal and the other wire (1) to COM. terminal of base down limit switch (2).
- (4) Install switch bracket (7, Figure 4-10) on shaft of base actuator (8) and secure with two lockwashers (6) and screws (5).
- (5) Install inner shroud (3) and outer shroud (2) on base casting (4) and secure with seven screws (1).
- (6) Plug chair power cord into wall outlet.

### NOTE

The trip arms of the limit switches should be tripped when the base up function is at 2/3 of it total height.

- (7) Run TABLE UP function up until the table top is at 2/3 of its total height.
- (8) If limit switches trip too early, loosen two screws (7, Figure 4-11) and slide limit switches (2 and 4) downward slightly; then tighten two screws (7).

If limit switches trip too late, loosen two screws (7) and slide limit switches (2 and 4) upward slightly; then tighten two screws (7).

- (9) Repeat steps 7 and 8 until limit switches are adjusted so they trip when table top reaches 2/3 of its total height.

#### 4.10 Typical Foot Pedal Footswitch Removal / Installation

##### A. Removal



#### WARNING

Always disconnect the power cord from the wall outlet before removing any of the table's covers / shrouds or making any repairs to prevent the possibility of electrical shock. Failure to comply with these instructions could result in severe personal injury or death.

- (1) Unplug chair power cord from wall outlet.
- (2) Remove screw (1, Figure 4-12), lockwasher (2), and pedal (3) from foot switch bracket (4).
- (3) Remove two locknuts (5), screws (6), two insulators (7), and footswitch (8) from footswitch bracket (4).
- (4) Tag and disconnect two or three wires (9) from terminals of footswitch (8). Remove footswitch.

##### B. Installation

- (1) Connect two or three wires (9) to terminals of footswitch (8).
- (2) Install footswitch (8) on foot switch bracket (4) and secure with two insulators (7), screws (6), and locknuts (5).

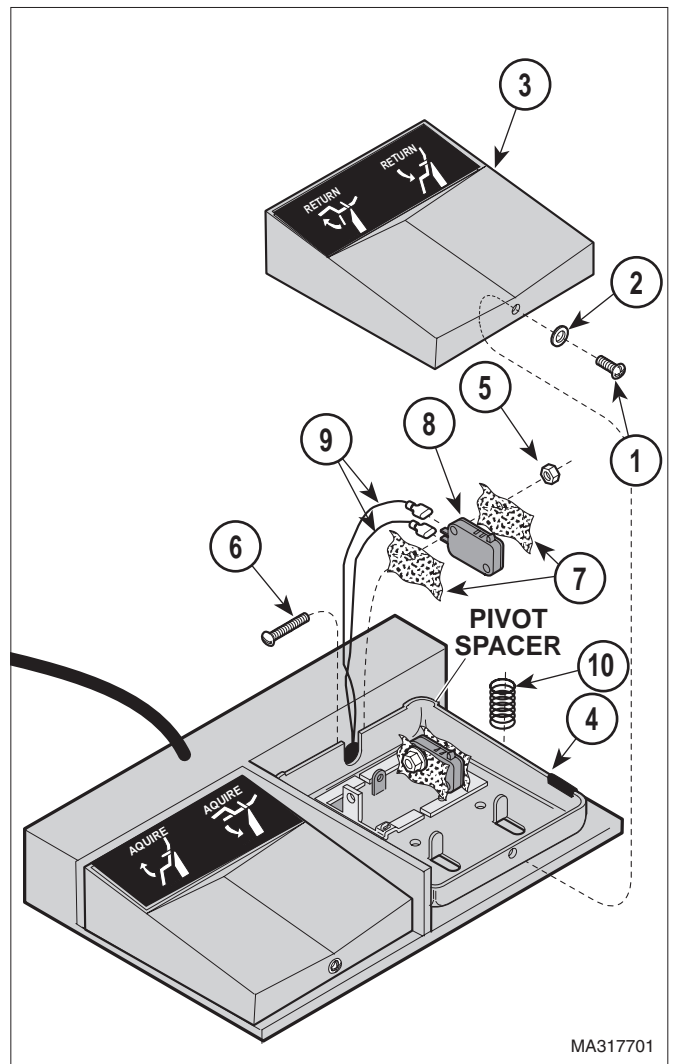

**Figure 4-12. Typical Foot Pedal Footswitch Removal / Installation**

- (3) Ensure springs (10) are in position and have not fallen off.
- (4) Install pedal (3) on foot switch bracket (4) and secure with lockwasher (2) and screw (1), making sure pedal is mounted on pivot spacer.
- (5) Plug chair power cord into wall outlet.





**SECTION V  
SCHEMATICS AND DIAGRAMS**

**5.1 Electrical Schematics / Wiring Diagrams**

between the electrical components in the chair. Figures 5-3 and 5-4 illustrate the logic/current flow between the electrical components in the chair.

Figures 5-1 and 5-2 illustrate the wiring connections

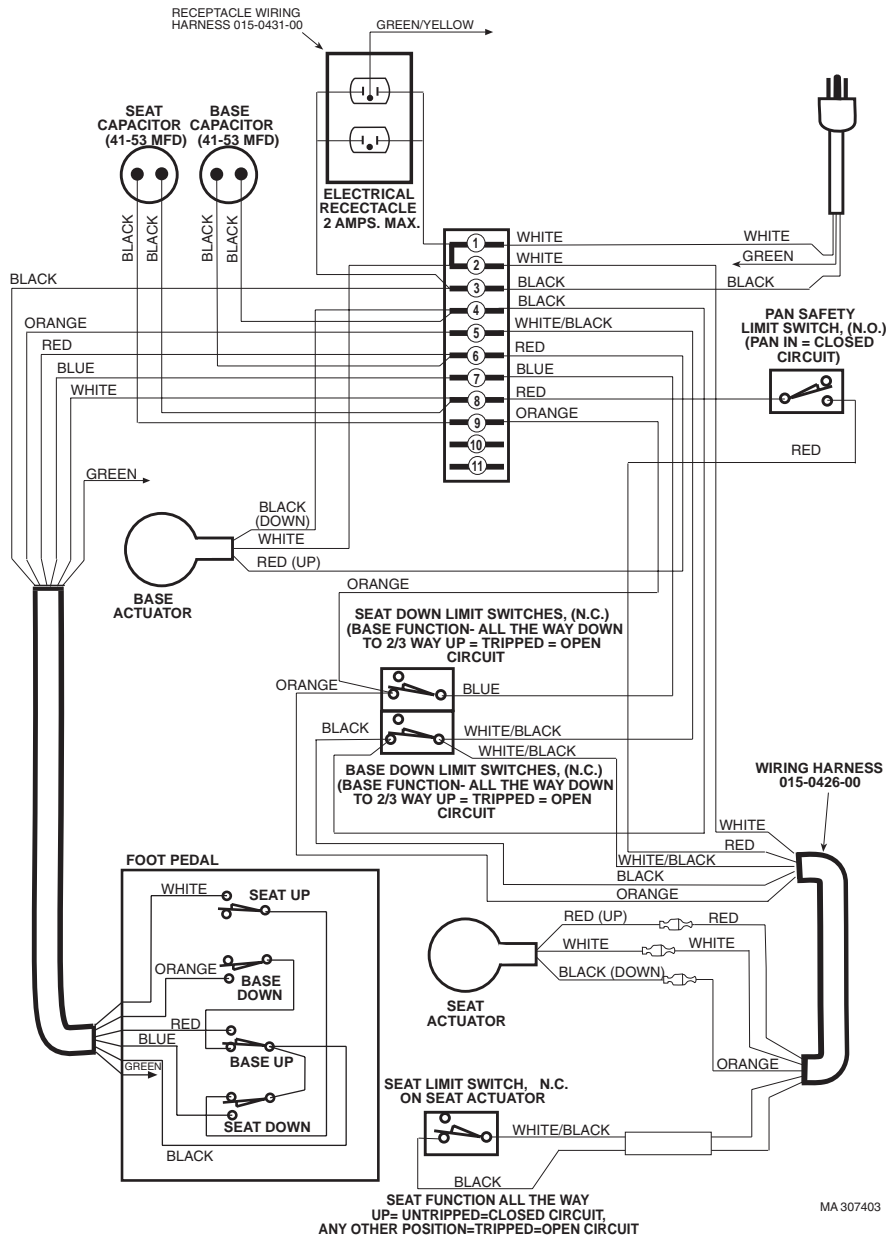

**Figure 5-1 Wiring Diagram (Used on Domestic Units with Serial Numbers: BK1000 Thru BK1271)**

**Figure 5-1 (Sheet 1 of 2). Wiring Diagram (Applies To 115 VAC Domestic Units With Serial Numbers BK-1000 Thru BK-1271)**

# SECTION V SCHEMATICS AND DIAGRAMS

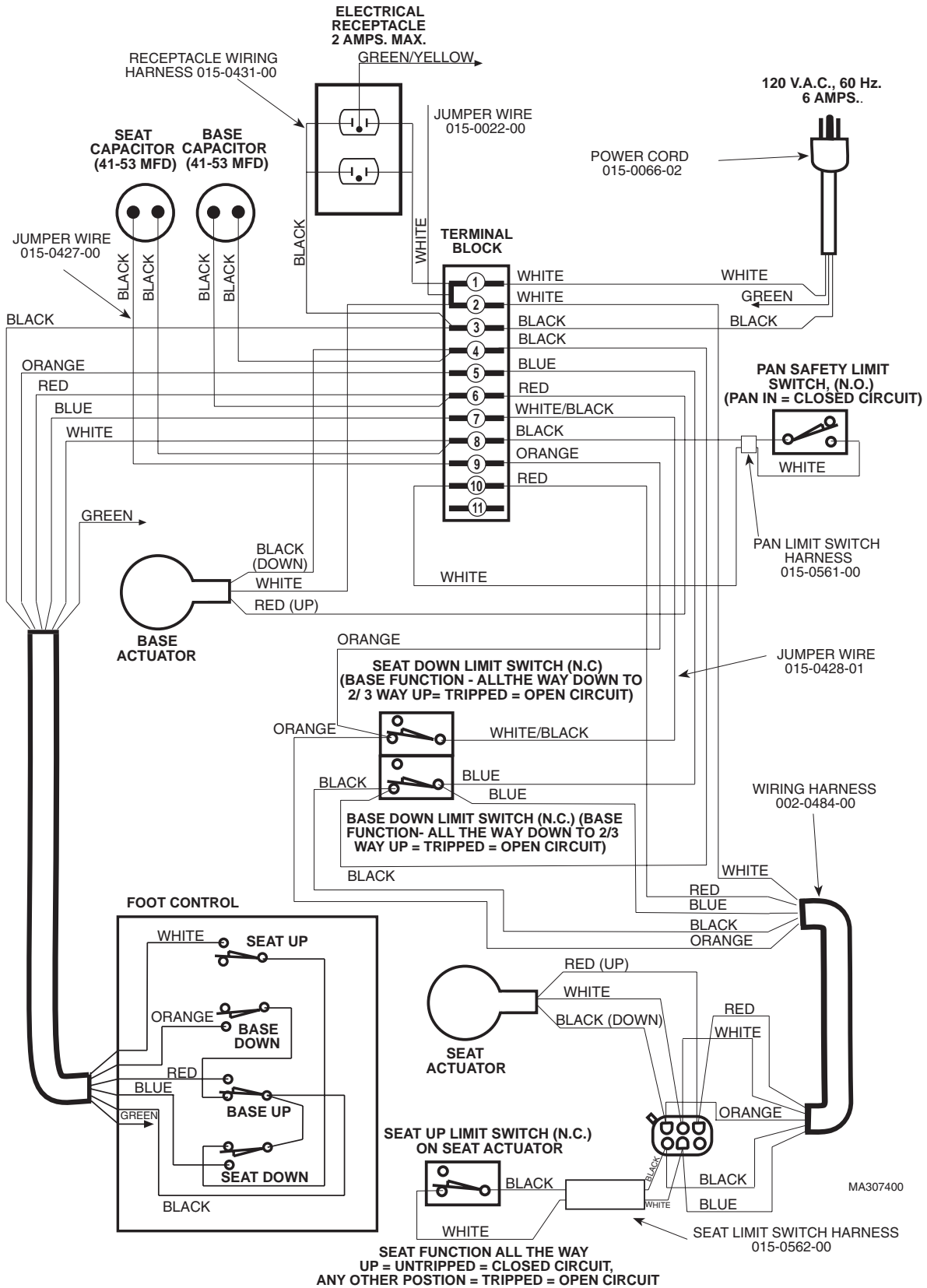

**Figure 5-1 (Sheet 2 of 2). Wiring Diagram**  
(Applies To 115 VAC Domestic Units With Serial Numbers BK-1272 and FH-1000 Thru Present)

# SECTION V SCHEMATICS AND DIAGRAMS

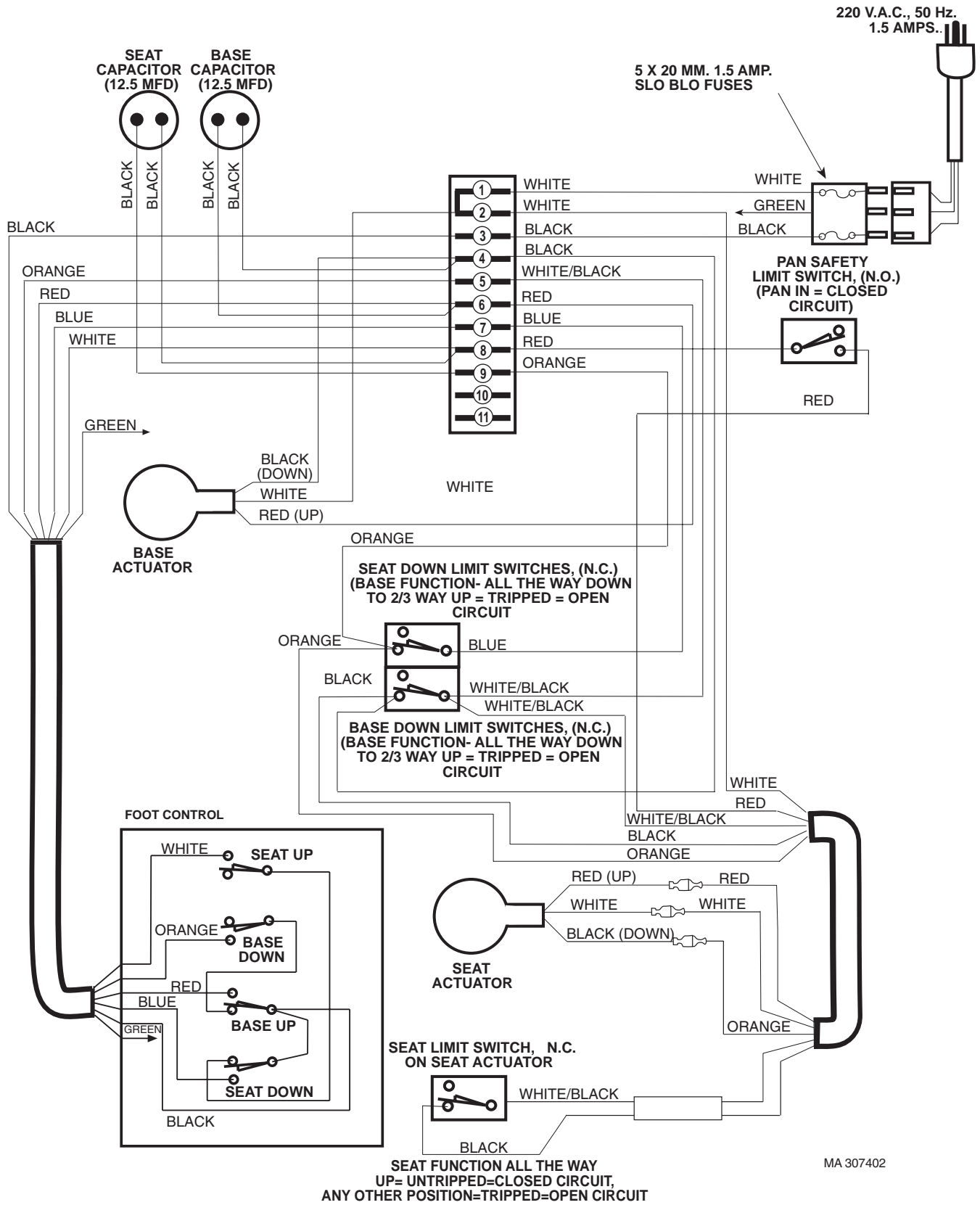

MA 307402

**Figure 5-2 (Sheet 1 of 2). Wiring Diagram  
(Applies To 220 VAC Export Units With Serial Numbers V-1000 Thru V-1575)**

# SECTION V SCHEMATICS AND DIAGRAMS

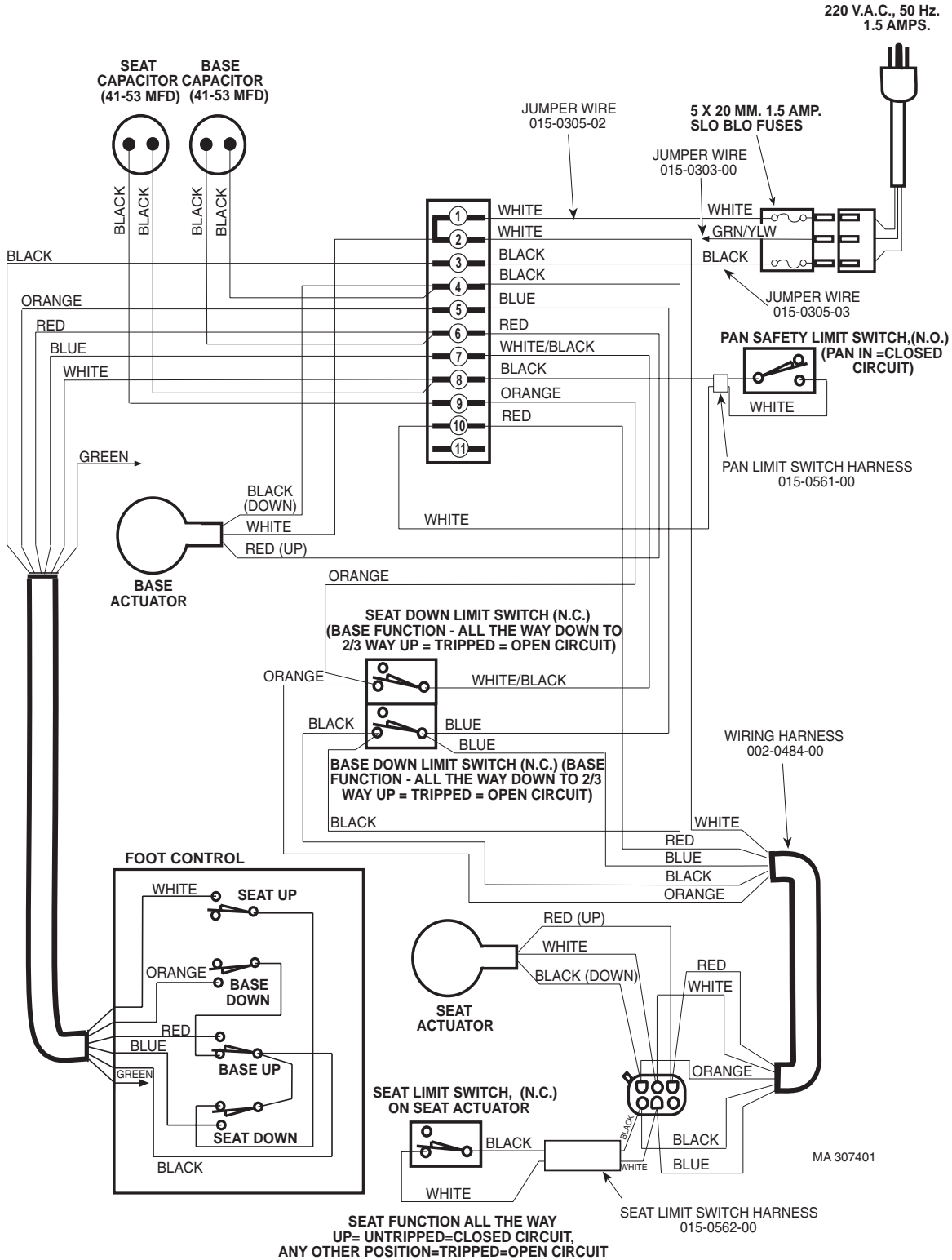

**Figure 5-2 Wiring Diagram (Used on Export Units with Serial Numbers: V 1576 Thru Present)**

**Figure 5-2 (Sheet 2 of 2). Wiring Diagram (Applies To 220 VAC Export Units With Serial Numbers V-1576 Thru Present)**

# SECTION V SCHEMATICS AND DIAGRAMS



**Positions:**

- Pan Switch - CLOSED
- Seat Down Switch- OPEN
- Base Down Switch - OPEN
- Seat Up Switch - CLOSED

**Conclusions:**

- Base can power either direction.
- Seat can power up only!

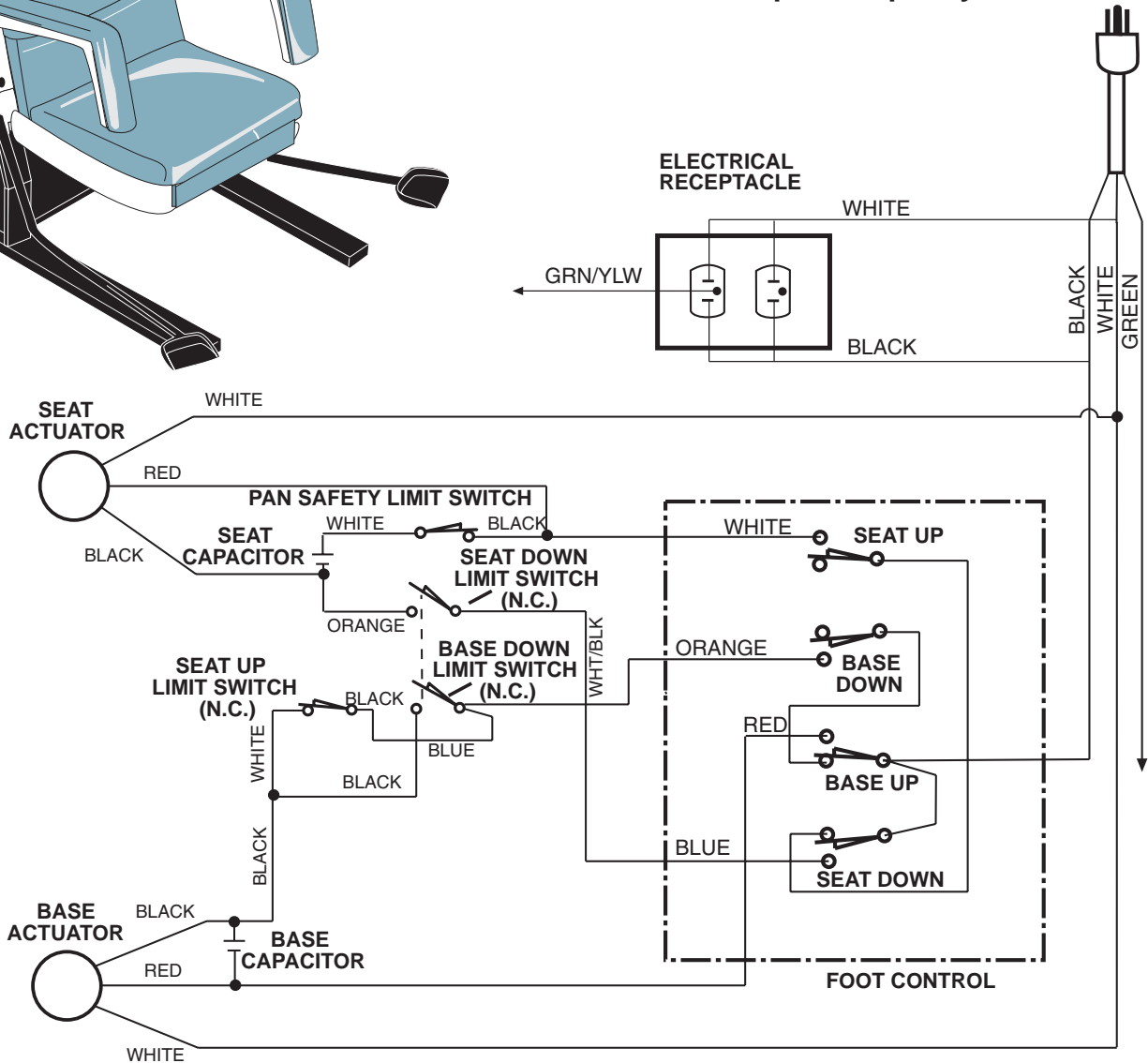

MA318101

**Figure 5-3. Electrical Schematic (Applies To 115 VAC Domestic Units)**

# SECTION V SCHEMATICS AND DIAGRAMS

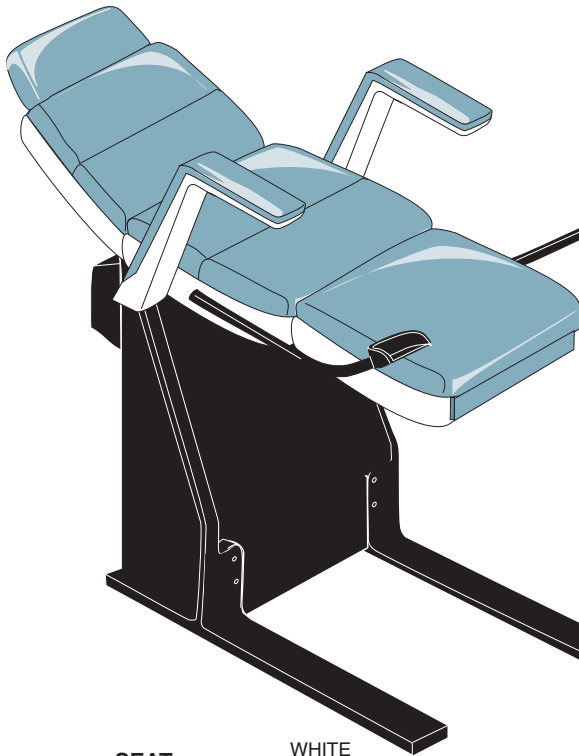

**Positions:**

- Pan Switch -
- Seat Down Switch-
- Base Down Switch -
- Seat Up Switch -

CLOSED  
CLOSED  
CLOSED  
CLOSED

**Conclusions:**

- Base can power both up and down.
- Seat can power both up and down.

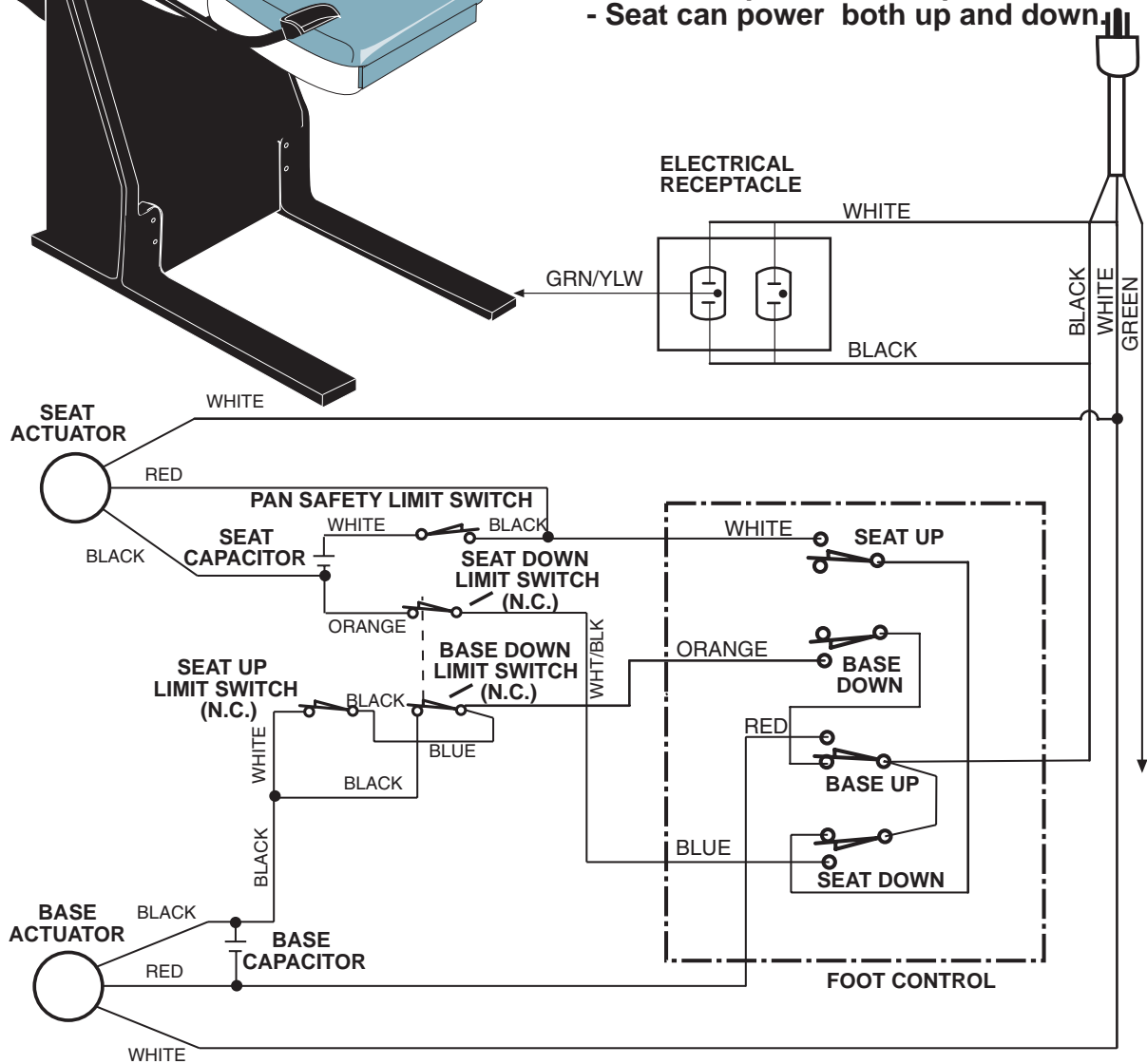

MA318102

Figure 5-3. Electrical Schematic (Applies To 115 VAC Domestic Units)

# SECTION V SCHEMATICS AND DIAGRAMS

**Positions:**

- Pan Switch -
- Seat Down Switch-
- Base Down Switch -
- Seat Up Switch -

CLOSED  
CLOSED  
CLOSED  
OPEN

**Conclusions:**

- Base can go down only until limit switches are contacted (2/3).
- Seat can go either direction.

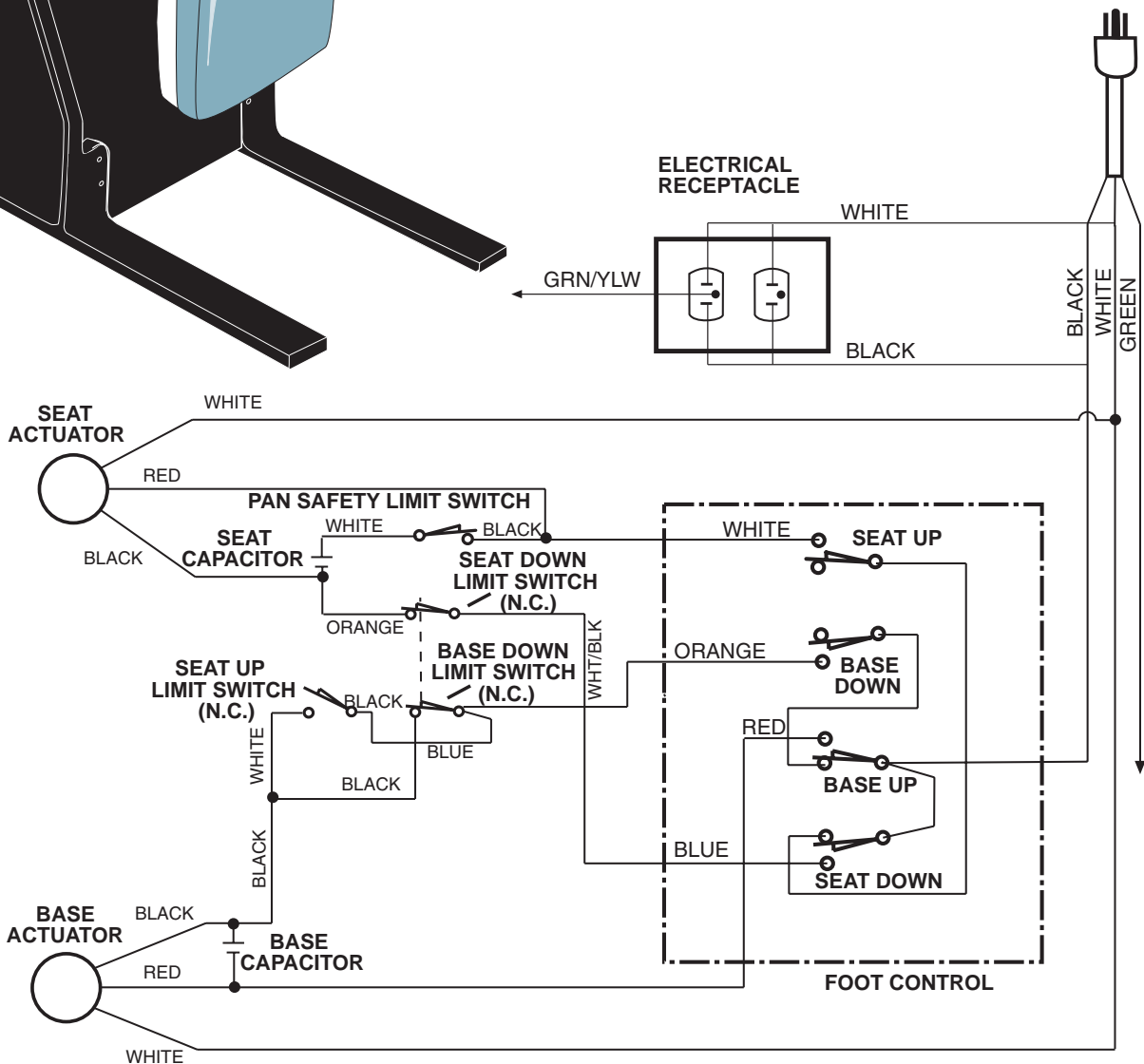
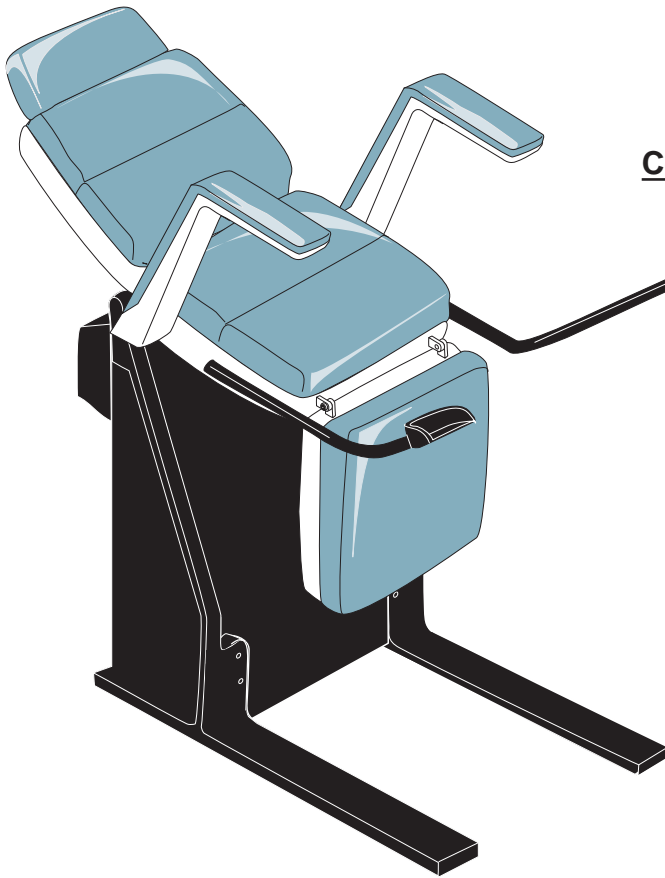

Figure 5-3. Electrical Schematic (Applies To 115 VAC Domestic Units)

MA318103

# SECTION V SCHEMATICS AND DIAGRAMS



**Positions:**

- Pan Switch - CLOSED
- Seat Down Switch- OPEN
- Base Down Switch - OPEN
- Seat Up Switch - CLOSED

**Conclusions:**

- Base can power either direction.
- Seat can power up only!

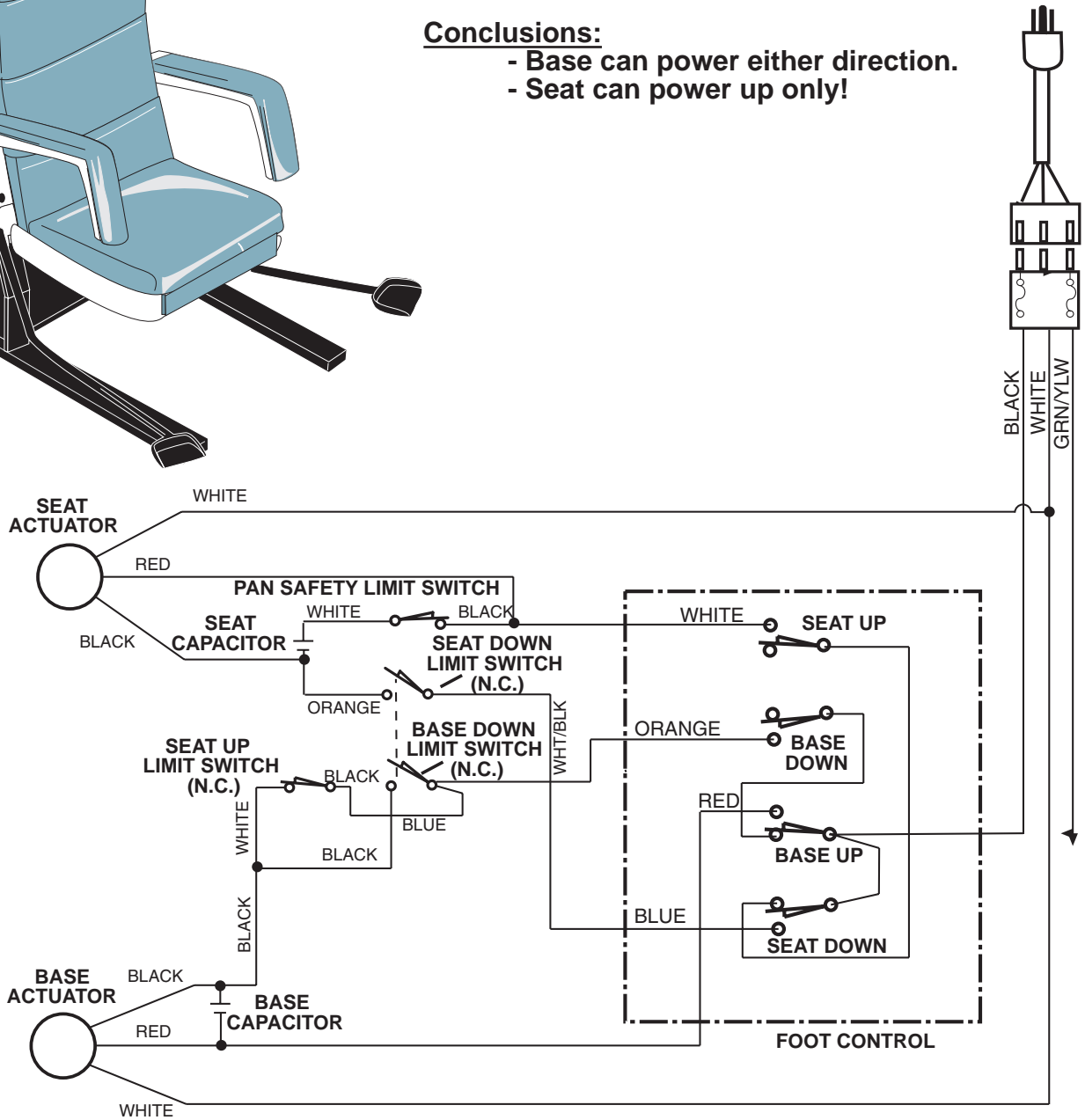

MA318201

**Figure 5-4. Electrical Schematic (Applies To 220 VAC Export Units)**



# SECTION V SCHEMATICS AND DIAGRAMS

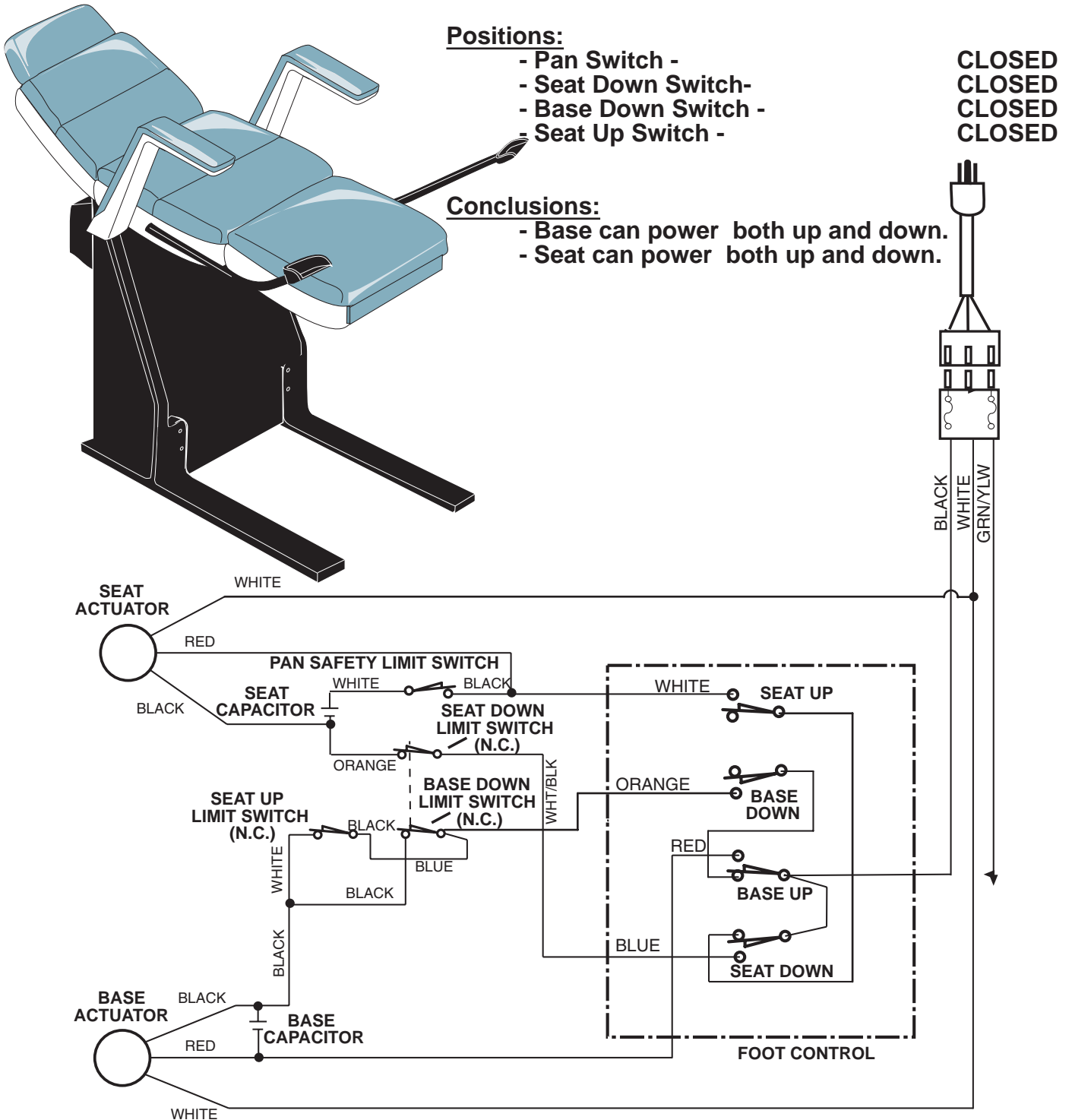

MA318202

Figure 5-4. Electrical Schematic (Applies To 220 VAC Export Units)

# SECTION V SCHEMATICS AND DIAGRAMS

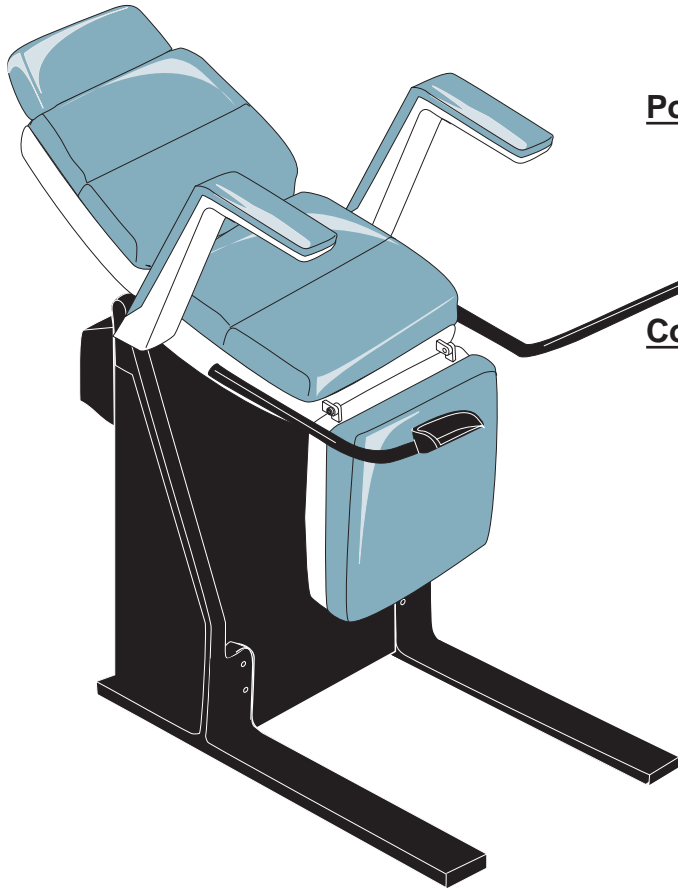

**Positions:**

- Pan Switch -
- Seat Down Switch -
- Base Down Switch -
- Seat Up Switch -

CLOSED  
CLOSED  
CLOSED  
OPEN

**Conclusions:**

- Base can go down only until limit switches are contacted (2/3).
- Seat can go either direction.

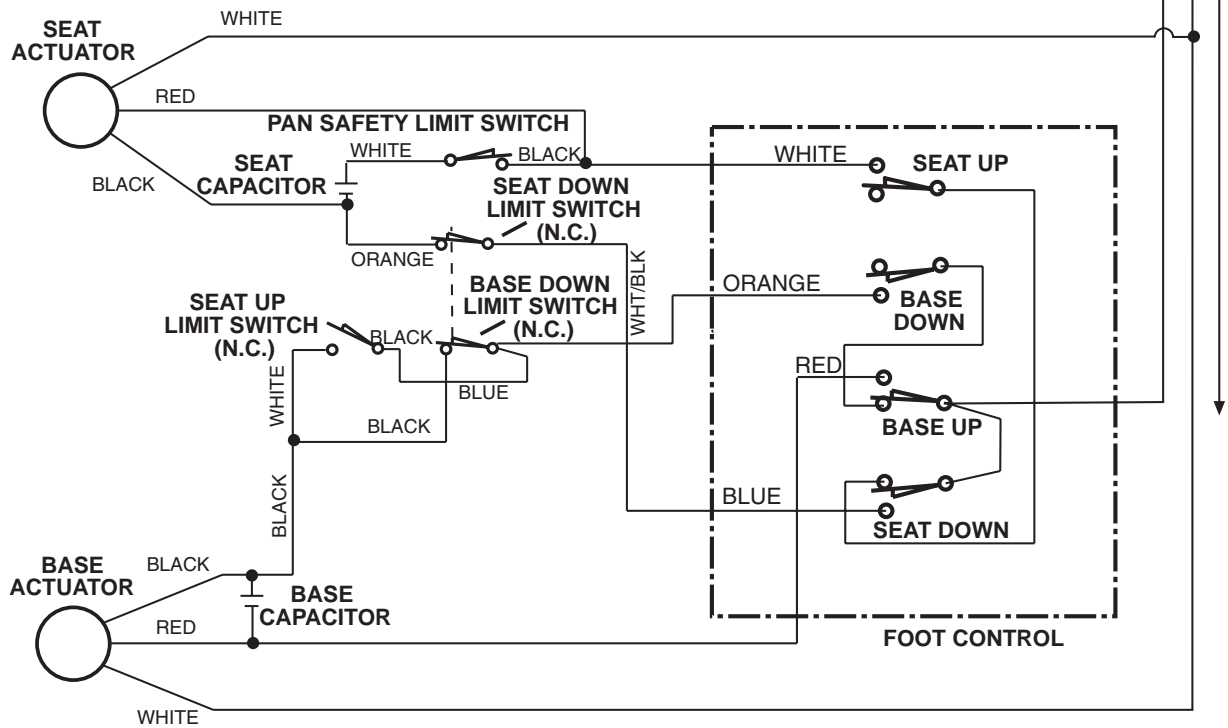

MA318203

Figure 5-4. Electrical Schematic (Applies To 220 VAC Export Units)

## **SECTION VI PARTS LIST**

### **6.1 Introduction**

The illustrated parts list provides information for identifying and ordering the parts necessary to maintain the unit in peak operating condition. Refer to paragraph 1.5 for parts ordering information.

The parts list also illustrates disassembly and assembly relationships of parts.

### **6.2 Description of Columns**

The *Item* column of the parts list gives a component its own unique number. The same number is given to the component in the parts illustration. This allows a part number of a component to be found if the technician can visually spot the part on the illustration. The technician simply finds the component in question on the illustration and notes the item number of that component. Then, he finds that item number in the parts list. The row corresponding to the item number gives the technician the part number, a description of the component, and quantity of parts per subassembly. Also, if a part number is known, the location of that component can be determined by looking for the item number of the component on the illustration.

The *Part No.* column lists the MIDMARK part number for that component.

The *Description* column provides a physical description of the component.

The *Qty.* column lists the number of units of a particular component that is required for the subassembly. The letters "AR" denote "as required" when quantities of a particular component cannot be determined, such as: adhesive.

Bullets [ • ] in the *Part No.* column and the *Description* column show the indenture level of a component. If a component does not have a bullet, it is a main component of that illustration. If a component has a bullet, it is a subcomponent of the next component listed higher in the parts list than itself that does not have a bullet. Likewise, if a component has two bullets, it is a subcomponent of the next component listed higher in the parts list than itself that has only one bullet.

### **6.3 Torque Specifications and Important Assembly Notes**

When specific assembly torque specifications, measurements, or procedures have been identified, by our engineering department, as required to assure proper function of the unit, those torque specifications measurements, and procedures will be noted on the parts illustrations. Adherence to these requirements is essential.

# Pictorial Index

## SECTION VI PARTS LIST



MA307603i

Item	Part No.	Description	Page	Item	Part No.	Description	Page
1	•	413 Lithotomy Table		10	•	• Base and Panels .....	6-12
2	•	• Labels and Decals .....	6-3	11	•	• Linkage Assembly .....	6-13
3	•	• Upholstery .....	6-4	12	•	• Pan Assembly .....	6-14
4	•	• Main Frame .....	6-5	13	•	• Footrest Assembly .....	6-15
5	•	• Stirrup Assembly .....	6-6	14	•	• Seat Component .....	6-16
6	•	• Stirrup .....	6-7	15	•	• Seat Actuator .....	6-17
7	•	• Armrest Assembly .....	6-8	16	•	• Footswitch .....	6-18
8	•	• Cross Support .....	6-9	17	•	• Back Panel .....	6-19
9	•	• Base Components .....	6-10	18	•	• Wiring Locations .....	6-20
		• Base Actuator .....	6-11	19	•	• Export .....	6-21

Always Specify Model & Serial Number

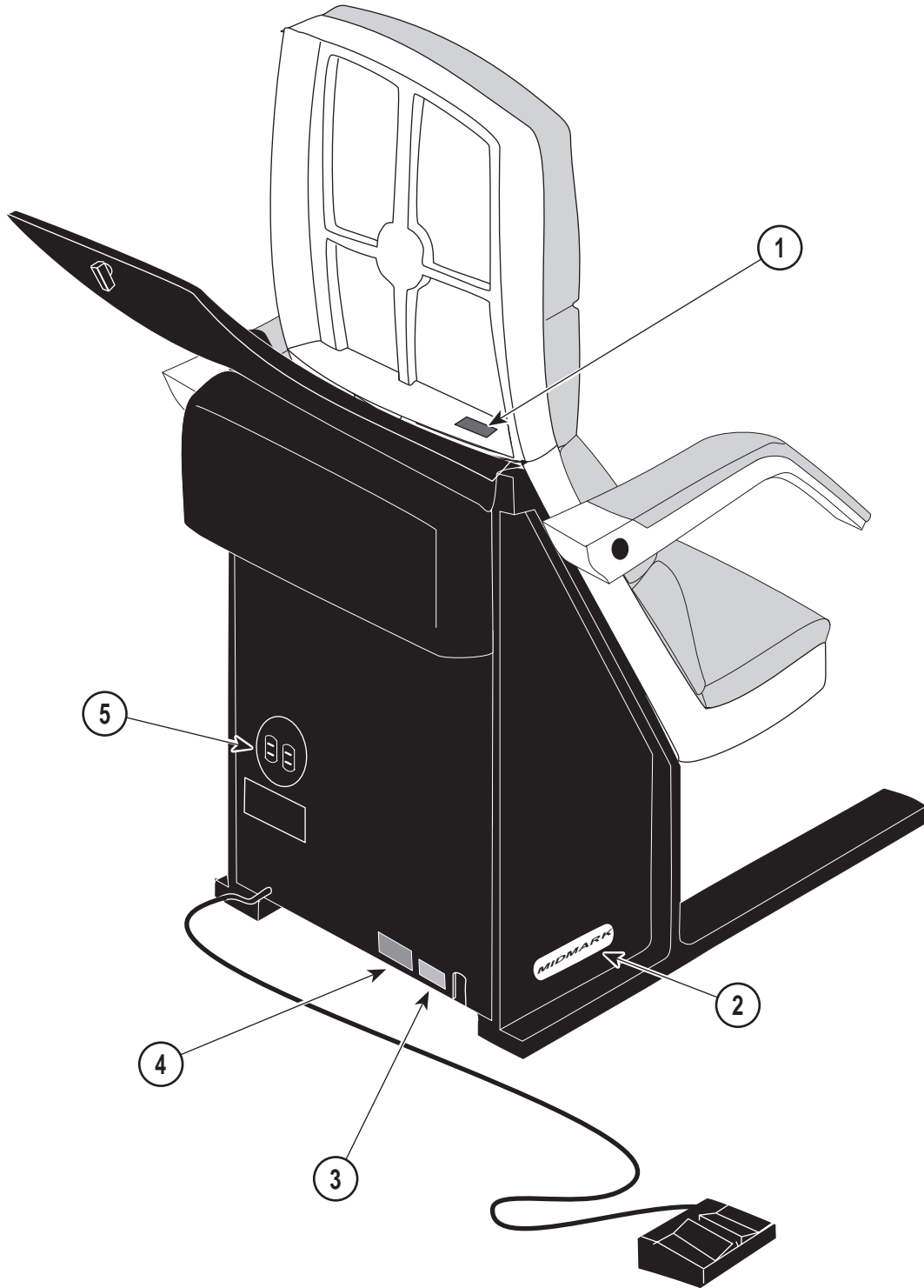

MA309300

Item	Part No.	Description	Page	Item	Part No.	Description	Page
1	•	Serial Number .....	1	4	061-0293-00	Caution Label .....	1
2	053-0297-13	Nameplate 413 .....	1	5	061-0174-00	Receptacle Label .....	1
3	061-0295-00	Cord Tag .....	1				

**Always Specify Model & Serial Number**

# Upholstery

## SECTION VI PARTS LIST

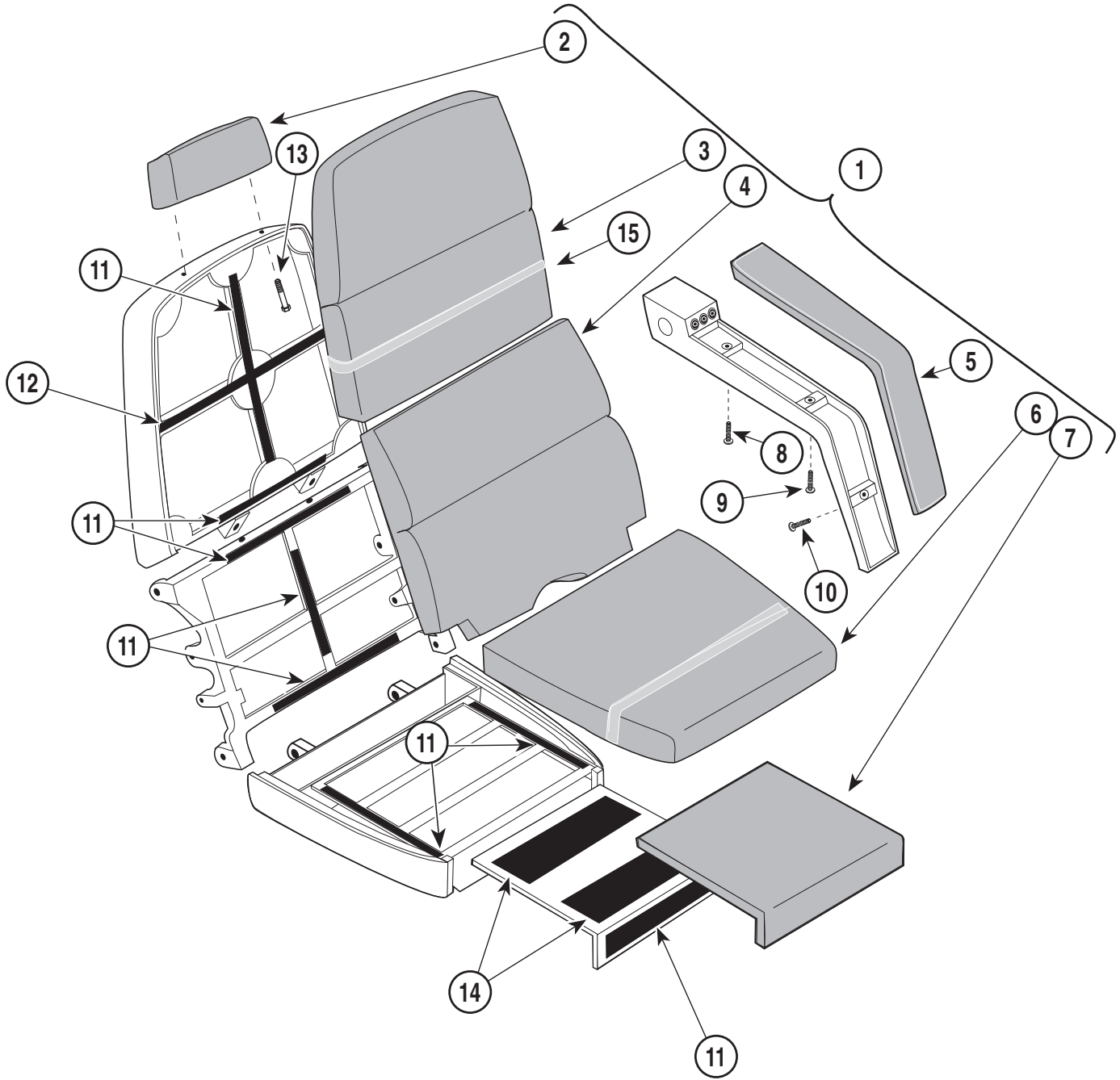

MA305600

Item	Part No.	Description	Qty.	Item	Part No.	Description	Qty.
1	002-0439-00	Upholstery Kit (Includes Items 2 thru 7) ..	1	7	•• <del>028-0181-XX</del>	Upholstered Foot Rest (*Specify Color) ..	1
	• <del>029-1111-00</del>	Upholstery Set (Includes Items 2 & 5) .....	1	8	042-0059-03	Joint Connector Bolt .....	2
	• <del>029-0647-XX</del>	Upholstery Set (Includes Items 3, 4, 6 & 7) .....	1	9	042-0059-05	Joint Connector Bolt .....	2
2	•• <del>028-0182-XX</del>	Upholstered Headrest (*Specify Color) ...	1	10	042-0059-02	Joint Connector Bolt .....	2
3	•• <del>028-0105-XX</del>	Upholstered Upper Back (*Specify Color)	1	11	053-0131-07	Velcro Tape 3/4"x 12 .....	8
4	•• <del>028-0153-XX</del>	Upholstered Lower Back (*Specify Color)	1	12	053-0131-05	Velcro Tape 5/8"x 15 (Item #12 must be cut in two pieces) .....	1
5	•• <del>028-0180-XX</del>	Upholstered Armrest (*Specify Color) .....	2	13	040-0312-19	Bolt .....	2
6	•• <del>028-0179-XX</del>	Upholstered Seat (*Specify Color) .....	1	14	053-0131-02	Velcro Tape 2"x 12 .....	2
				15	029-0452-00	Paper Tear Strip .....	2

\* Click on the Color Selector link above to see available colors.

**Always Specify Model & Serial Number**

# Main Frame Section

## SECTION VI PARTS LIST

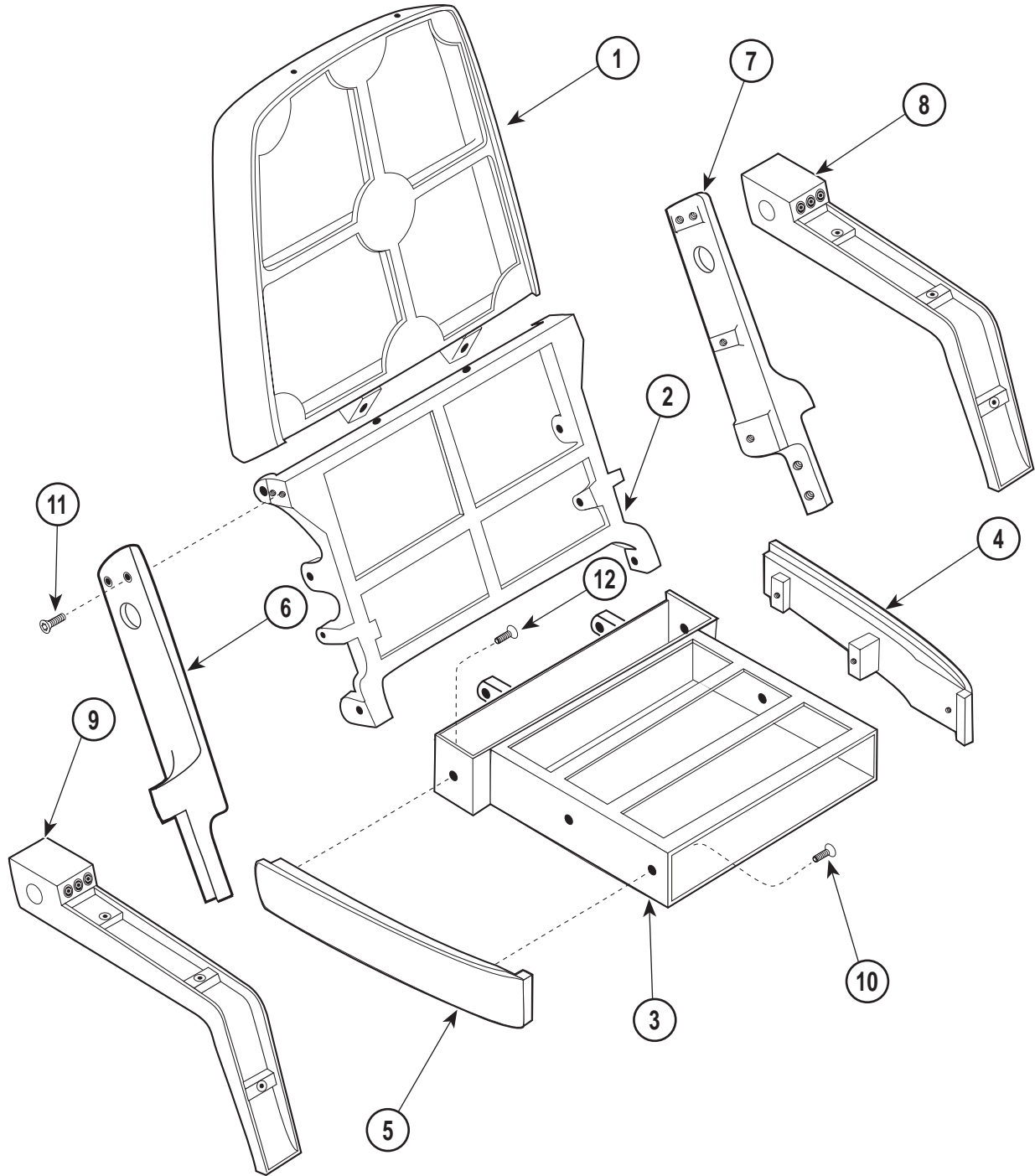

MA305700

**Used on units with Serial Number  
BK1000 thru BK1271 and V1000 thru V1575**

Item	Part No.	Description	Qty.	Item	Part No.	Description	Qty.
1	020-0039-03	Upper Back Casting .....	1	7	020-0056-01	L.H. Side Casting .....	1
2	020-0060-00	Lower Back Casting .....	1	8	020-0058-01	L.H. Arm Casting .....	1
3	030-0496-00	Seat Weldment .....	1	9	020-0058-00	R.H. Arm Casting .....	1
4	020-0057-01	L.H. Seat Casting .....	1	10	040-0250-66	Bolt .....	2
5	020-0057-00	R.H. Seat Casting .....	1	11	040-0250-33	Bolt .....	6
6	020-0056-00	R.H. Side Casting .....	1	12	040-0250-65	Bolt .....	4

**Always Specify Model & Serial Number**

# Main Frame Section

## SECTION VI PARTS LIST

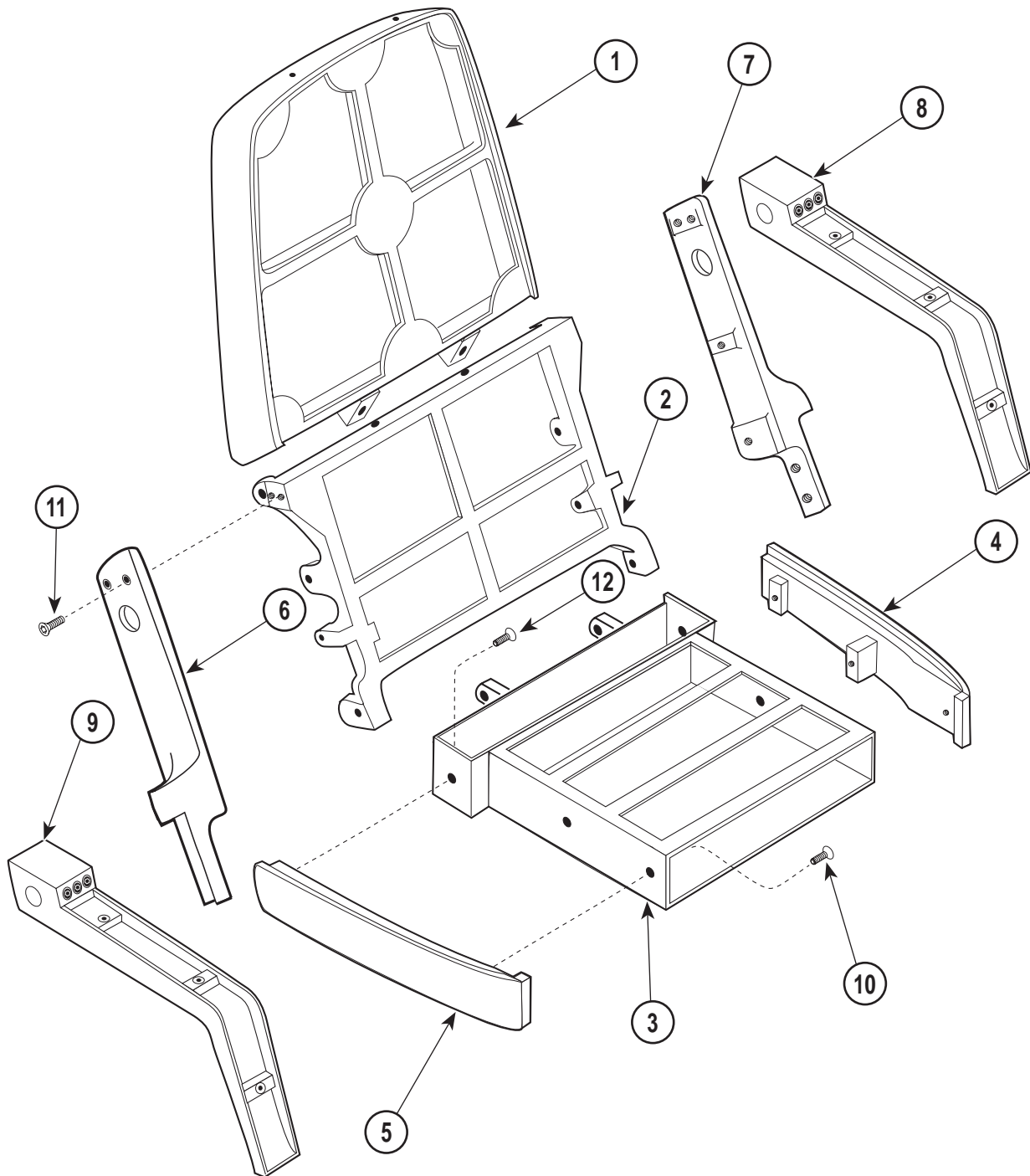

MA305700

**Used on 413 Units with Serial Numbers:  
BK 1272 Thru BK 2403      V 1576 Thru V 1789**

Item	Part No.	Description	Qty.	Item	Part No.	Description	Qty.
1	020-0039-03	Upper Back Casting .....	1	7	020-0056-01	L.H. Side Casting .....	1
2	020-0060-00	Lower Back Casting .....	1	8	020-0058-01	L.H. Arm Casting .....	1
3	030-0611-00	Seat Weldment .....	1	9	020-0058-00	R.H. Arm Casting .....	1
4	020-0057-01	L.H. Seat Casting .....	1	10	040-0250-66	Bolt .....	2
5	020-0057-00	R.H. Seat Casting .....	1	11	040-0250-33	Bolt .....	6
6	020-0056-00	R.H. Side Casting .....	1	12	040-0250-65	Bolt .....	4

**Always Specify Model & Serial Number**



# Main Frame Section

## SECTION VI PARTS LIST

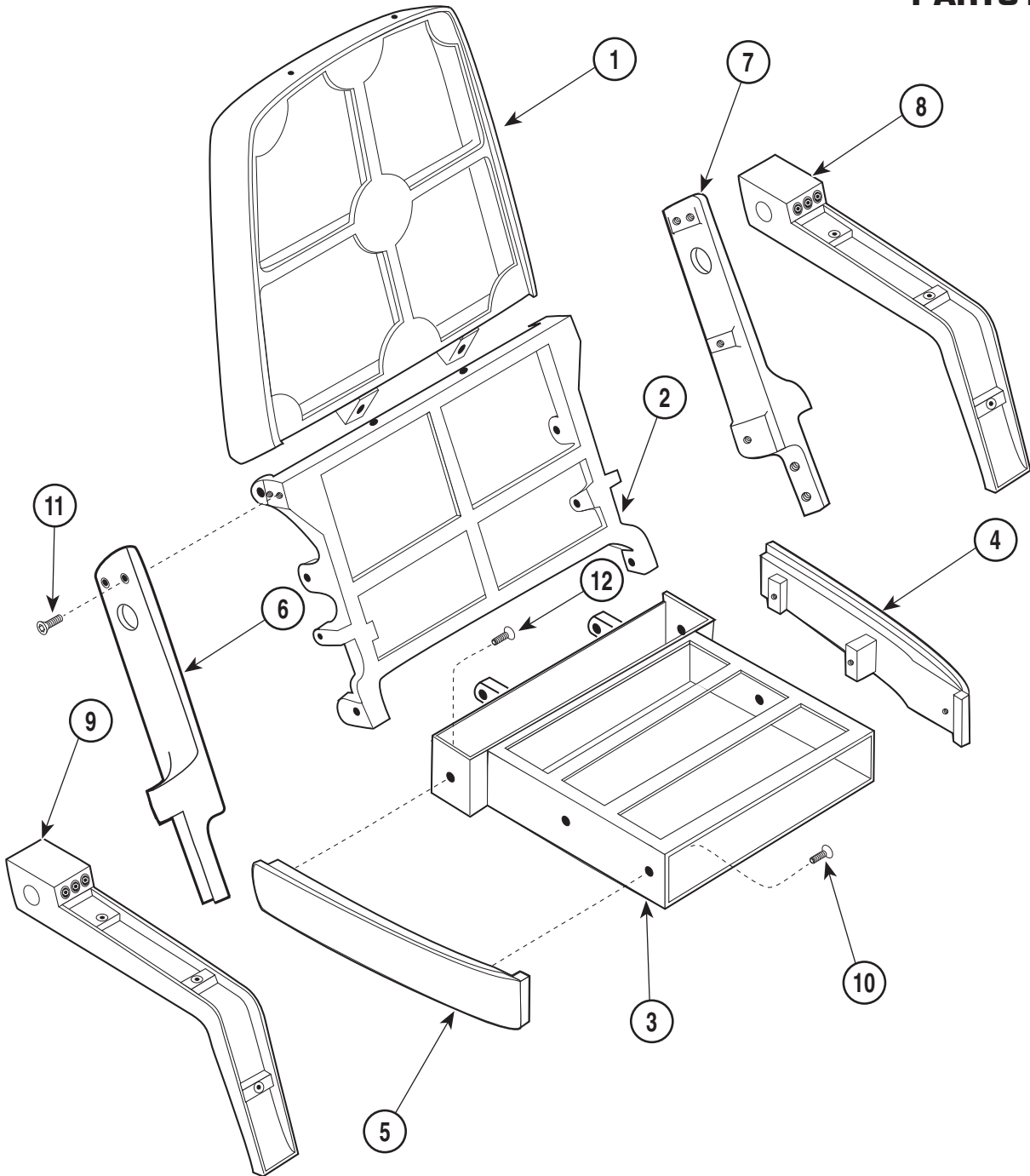

MA305700

**Used on 413 Units with Serial Numbers:  
BK 2404 Thru Present    V 1790 Thru Present  
FH 1000 Thru Present**

Item	Part No.	Description	Qty.	Item	Part No.	Description	Qty.
1	020-0039-04	Upper Back Casting .....	1	7	020-0056-05	L.H. Side Casting (Bolt-on Stirrups) .....	1
2	020-0060-01	Lower Back Casting .....	1	8	<del>020-0164-00</del>	R.H. Side Casting (Detachable Stirrups) .	1
3	030-0611-00	Seat Weldment .....	1	9	<del>020-0058-04</del>	L.H. Arm Casting .....	1
4	020-0057-05	L.H. Seat Casting .....	1	10	<del>020-0058-03</del>	R.H. Arm Casting .....	1
5	<del>020-0057-04</del>	R.H. Seat Casting .....	1	11	040-0250-66	Bolt .....	2
6	020-0056-04	R.H. Side Casting (Bolt-on Stirrups) .....	1	12	040-0250-51	Bolt .....	6
	<del>020-0164-00</del>	R.H. Side Casting (Detachable Stirrups) .	1		040-0250-65	Bolt .....	4

**Always Specify Model & Serial Number**

# Stirrup Assembly

## SECTION VI PARTS LIST

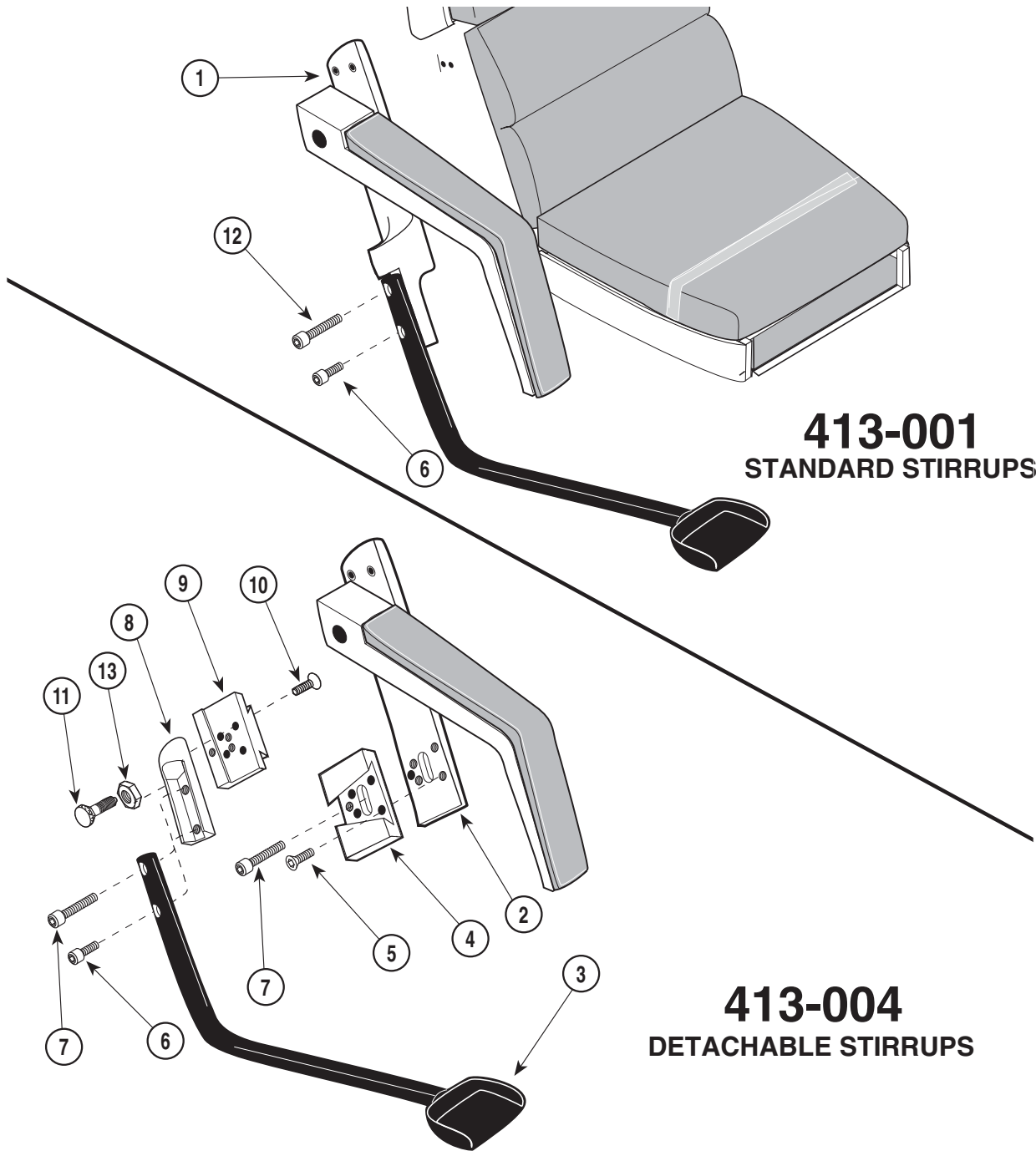

**413-001**  
**STANDARD STIRRUPS**

**413-004**  
**DETACHABLE STIRRUPS**

MA305800

Item	Part No.	Description	Qty.	Item	Part No.	Description	Qty.
1		R.H. Arm Assy. (Refer to "Arm Rest Assembly" Elsewhere) .....	Ref.	4	050-3478-00	Sideplate Interlock Assy. ....	2
		L.H. Arm Assy. (Refer to "Arm Rest Assembly" Elsewhere) .....	Ref.	5	040-0250-120	Bolts .....	8
2		R.H. Arm Assy. (Refer to "Arm Rest Assembly" Elsewhere) .....	Ref.	6	040-0375-31	Bolt .....	2
		L.H. Arm Assy. (Refer to "Arm Rest Assembly" Elsewhere) .....	Ref.	7	040-0375-61	Bolt .....	2
3		R.H. Stirrup Leg Assy. (Refer to "Stirrups" Elsewhere) .....	1	8	020-0165-00	R.H. Stirrup Leg Block .....	1
		L.H. Stirrup Leg Assy. (Refer To "Stirrups" Elsewhere) .....	1		020-0165-01	L.H. Stirrup Leg Block .....	1
				9	050-3479-00	Stirrup Interlock Block .....	2
				10	040-0250-120	Screw .....	8
				11	016-0649-00	QuickRelease Plunger .....	2
				12	040-0375-32	Bolt .....	2
				13	041-0500-00	Jam Nut .....	2

Always Specify Model & Serial Number

# Stirrups

## SECTION VI PARTS LIST

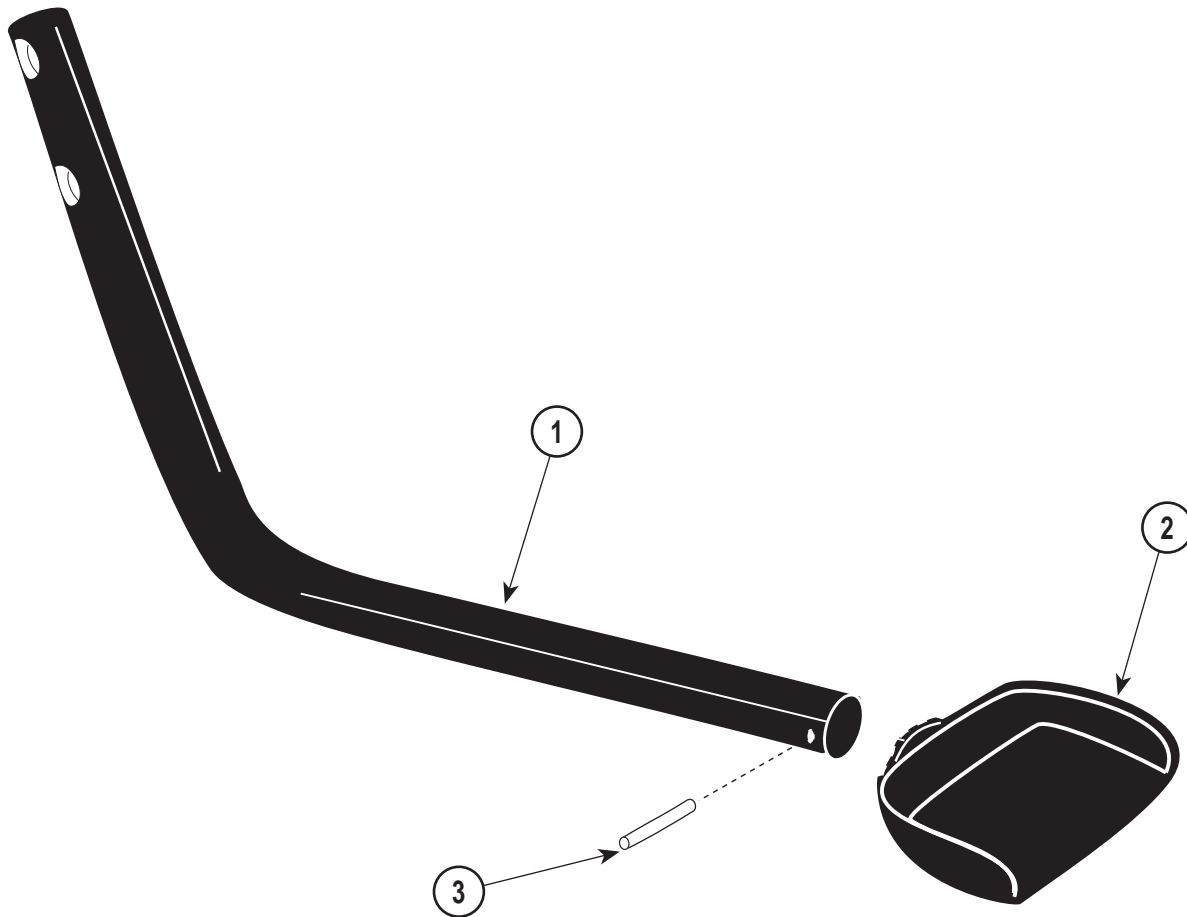

MA308600

**Used on 413 Units with Serial Numbers:  
BK 1000 Thru BK 3050    V 1000 Thru V 1897**

Item	Part No.	Description	Qty.	Item	Part No.	Description	Qty.
	029-0648-00	R.H. Stirrup Assembly .....	1	2	•020-0055-04	•Stirrup Casting (R.H. Hand) .....	1
	029-0648-01	L.H. Stirrup Assembly .....	1		•020-0055-05	•Stirrup Casting (L.H. Hand) .....	1
1	•057-0240-00	•Stirrup Leg (R. H. Side) .....	1	3	•042-0009-03	•Groove Pin .....	1
	•057-0240-01	•Stirrup Leg (L.H. Side) .....	1				

**Always Specify Model & Serial Number**

# Stirrups

## SECTION VI PARTS LIST

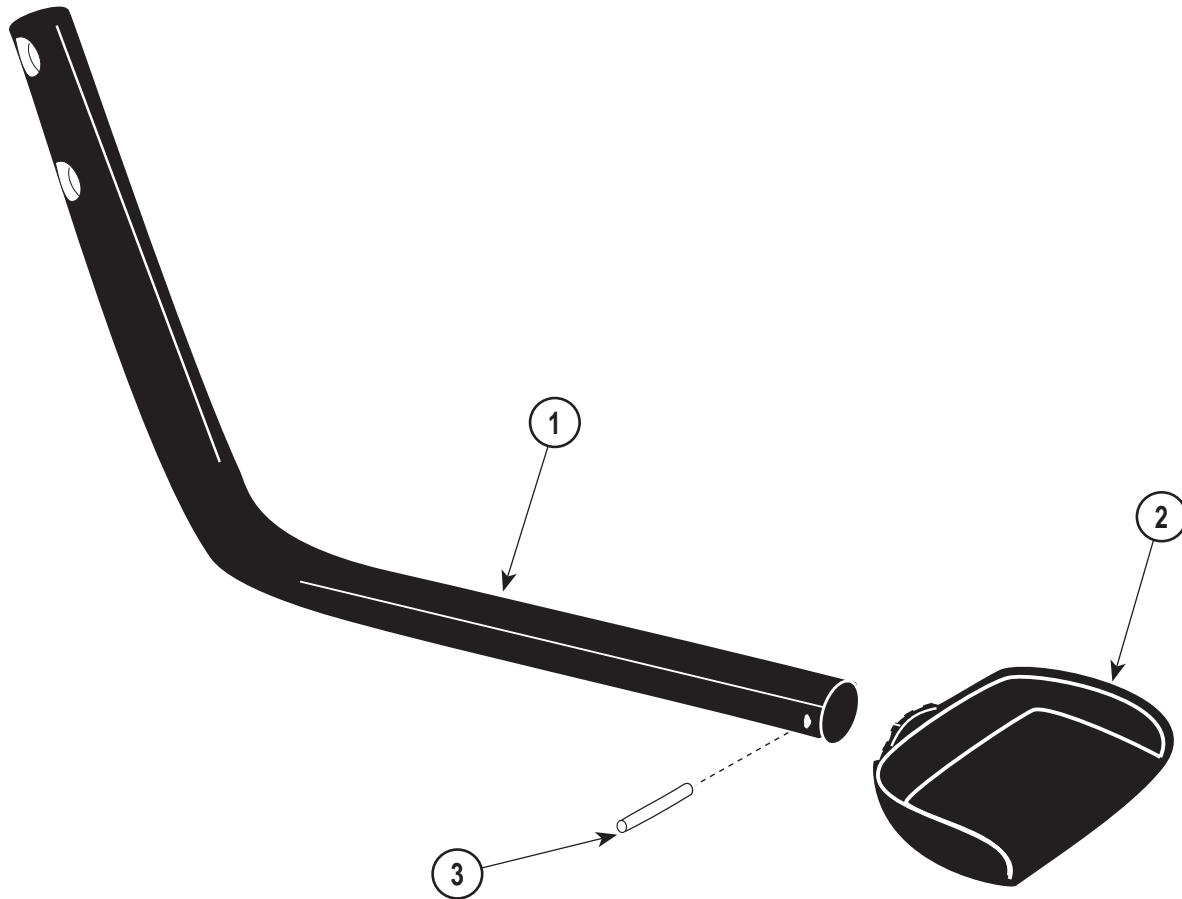

MA308600

**Used on 413 Units with Serial Numbers:  
BK 3051 Thru Present V 1898 Thru Present  
FH 1000 Thru Present**

Item	Part No.	Description	Qty.	Item	Part No.	Description	Qty.
	029-1892-00	R.H. Stirrup Assembly .....	1	2	•020-0055-04	•Stirrup Casting (R.H. Hand) .....	1
	029-1892-01	L.H. Stirrup Assembly .....	1		•020-0055-05	•Stirrup Casting (L.H. Hand) .....	1
1	•057-0527-00	•Stirrup Leg .....	1	3	•042-0009-03	•Groove Pin .....	1

**Always Specify Model & Serial Number**

# Arm Rest Assembly

## SECTION VI PARTS LIST

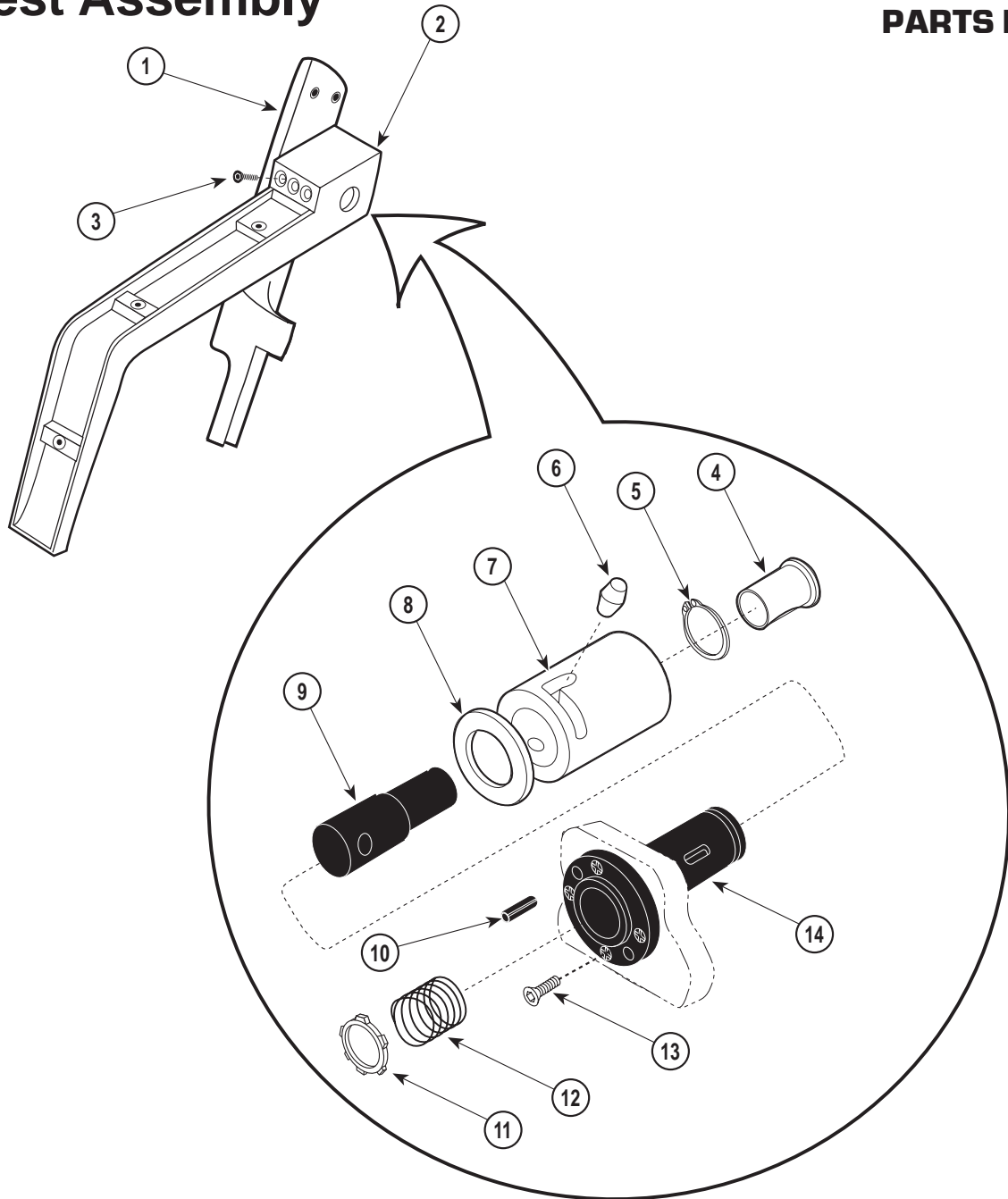

MA305902

**Used on 413 Units with Serial Numbers:  
BK 1000 Thru BK 2403      V 1000 Thru V 1789**

Item	Part No.	Description	Qty.	Item	Part No.	Description	Qty.
1	029-0649-00	R.H. Arm Rest Assembly ( With Bolt-on Stirrups, Refer to "Main Frame Section" for Side Casting (Includes Items 2 thru 14) )	1	6	• 042-0046-01	• Groove Pin .....	1
	029-0649-01	L.H. Arm Rest Assembly ( With Bolt-on Stirrups, Refer to "Main Frame Section" for Side Casting (Includes Items 2 thru 14) )	1	7	• 029-0692-00	• R.H. Latch Tube Assy. ....	1
2		• Arm Casting (Refer to "Main Frame Section" Elsewhere) .....	Ref.		• 029-0693-00	• L.H. Latch Tube Assy. ....	1
3	• 040-0250-52	• Bolt .....	4	8	• 045-0007-00	• Nylon Washer .....	1
4	• 053-0184-00	• Flanged Bearing .....	1	9	• 057-0146-00	• Push Button .....	1
5	• 042-0054-00	• Retaining Ring .....	1	10	• 042-0011-06	• Spirol Pin .....	2
				11	• 042-0055-00	• Internal Retaining Ring .....	1
				12	• 025-0029-00	• Compression Spring .....	1
				13	• 040-0250-33	• Bolt .....	4
				14	• 030-0651-00	• Arm Post .....	1

**Always Specify Model & Serial Number**

# Arm Rest Assembly

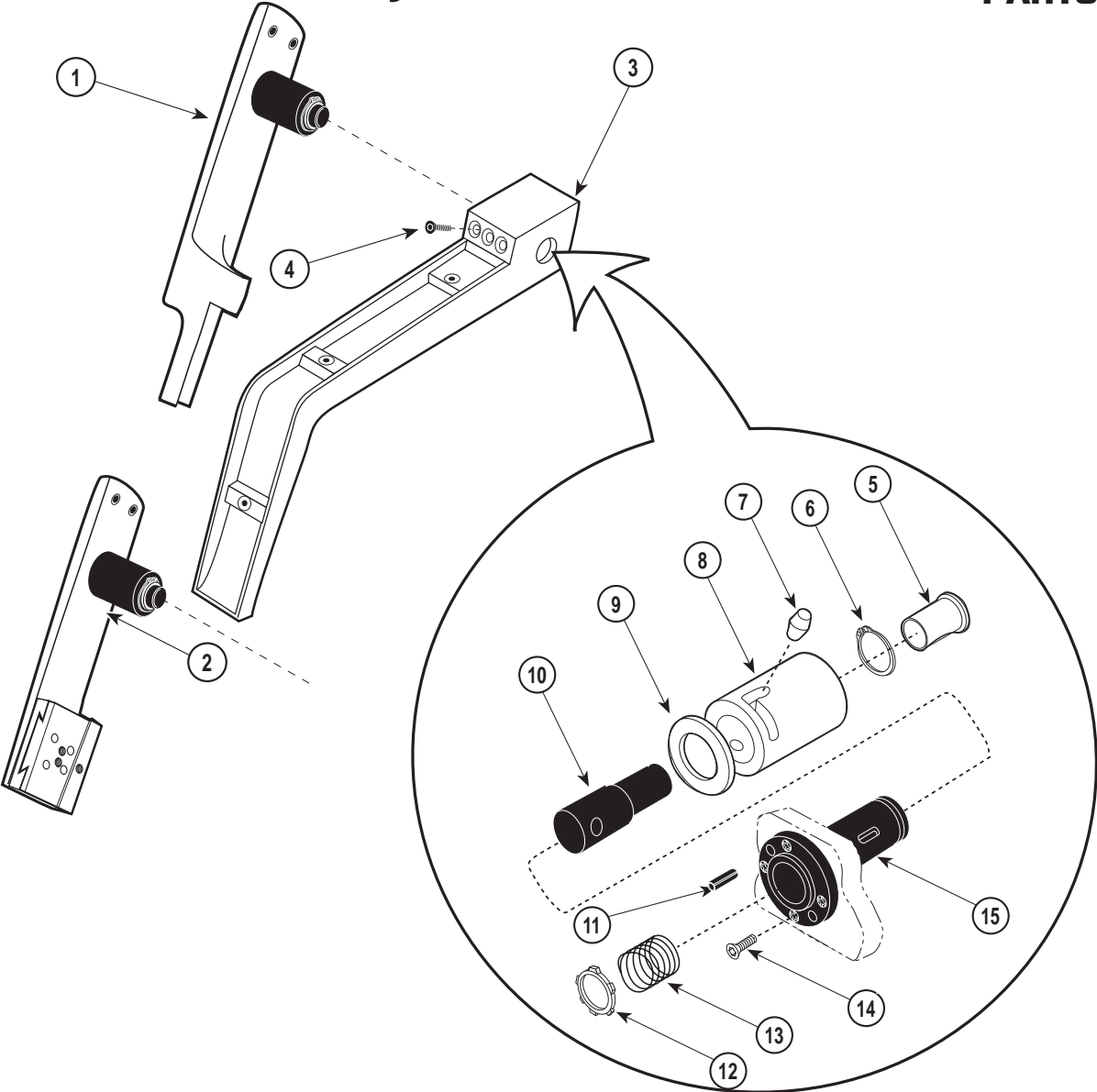

MA305900

**Used on 413 Units with Serial Numbers:  
BK 2404 Thru Present    V 1790 Thru Present  
FH 1000 Thru Present**

Item	Part No.	Description	Qty.	Item	Part No.	Description	Qty.
1	029-0649-02	R.H. Arm Rest Assembly ( With Bolt-on Stirrups, Refer to "Main Frame Section for Side Casting (Includes Items 3 thru 15) )	1	4	• 040-0250-52	• Bolt .....	4
	029-0649-03	L.H. Arm Rest Assembly ( With Bolt-on Stirrups, Refer to "Main Frame Section for Side Casting (Includes Items 3 thru 15) )	1	5	• 053-0184-00	• Flanged Bearing .....	1
2	029-1890-00	R.H. Arm Rest Assembly (With Detachable Stirrups, Refer to "Main Frame Section for Side Casting (Includes Items 3 thru 15) )	1	6	• 042-0054-00	• Retaining Ring .....	1
	029-1890-01	L.H. Arm Rest Assembly (With Detachable Stirrups, Refer to "Main Frame Section for Side Casting (Includes Items 3 thru 15) )	1	7	• 042-0046-01	• Groove Pin .....	1
3		• Arm Casting (Refer to "Main Frame Section" Elsewhere) .....	Ref.	8	029-0692-00	• R.H. Latch Tube Assy. ....	1
				9	• 029-0693-00	• L.H. Latch Tube Assy. ....	1
				10	• 045-0007-00	• Nylon Washer .....	1
				11	• 057-0146-00	• Push Button .....	1
				12	• 042-0011-06	• Spirol Pin .....	2
				13	• 042-0055-00	• Internal Retaining Ring .....	1
				14	• 025-0029-00	• Compression Spring .....	1
				15	• 040-0250-33	• Bolt .....	4
					• 030-0651-00	• Arm Post .....	1

**Always Specify Model & Serial Number**

# Cross Support

## SECTION VI PARTS LIST

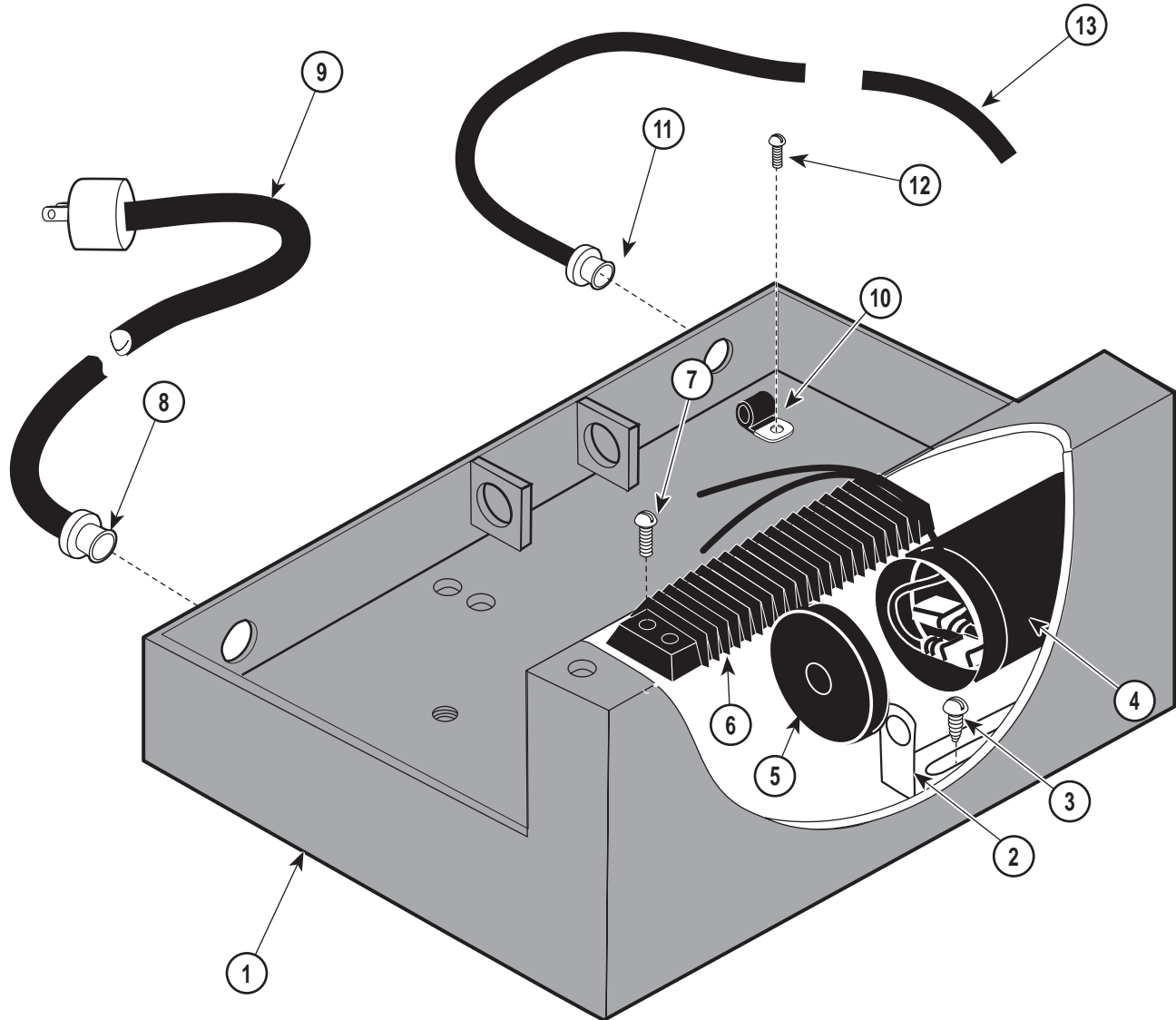

MA306100

**Used on 413 Units with Serial Numbers:  
BK 1000 Thru BK 2512    V 1000 Thru V 1804**

Item	Part No.	Description	Qty.	Item	Part No.	Description	Qty.
1	030-0359-00	Cross Support .....	1	9	040-0006-33	Screw .....	2
2	015-0412-00	Mounting Bracket .....	2	10	015-0002-01	Strain Relief .....	1
3	040-0010-62	Screw .....	4	11	015-0066-02	Power Cord .....	1
4	015-0437-03	Capacitor .....	2	12	015-0002-02	Strain Relief .....	1
5	015-0413-01	Capacitor Cap .....	2	13	015-0001-00	Wire Clamp .....	2
6	015-0009-01	Terminal Board .....	1	14	040-0010-12	Screw .....	1
7	040-0010-47	Screw .....	1	15	•	•Footswitch (Refer to "Footswitch Com- ponents" Elsewhere) .....	Ref.
8	045-0001-31	Lock Washer .....	1				

**Always Specify Model & Serial Number**

# Cross Support

## SECTION VI PARTS LIST

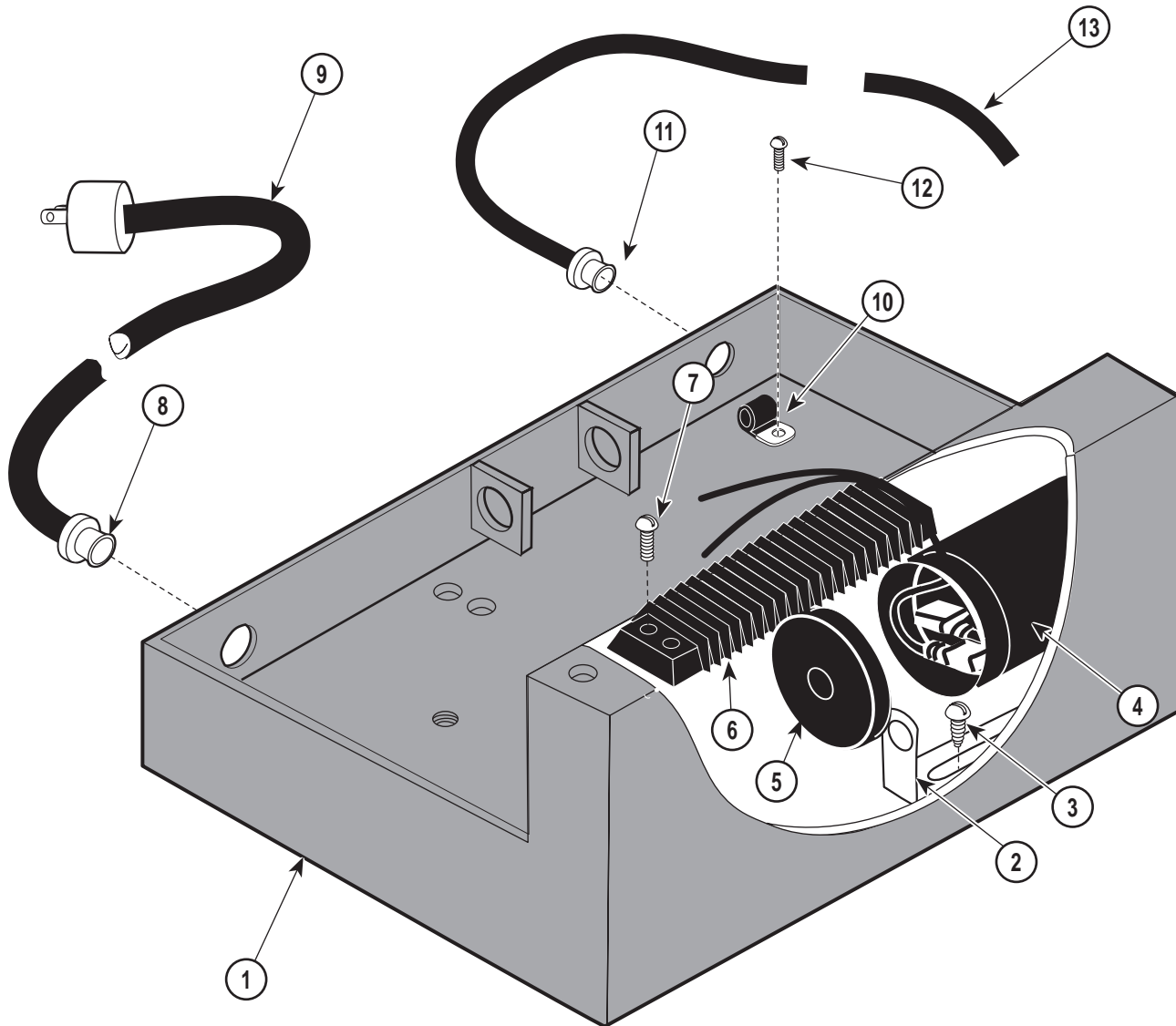

MA306100

**Used on 413 Units with Serial Numbers:  
BK 2513 Thru BK3407    V 1805 Thru V1955  
FH1000 Thru 1003**

Item	Part No.	Description	Qty.	Item	Part No.	Description	Qty.
1	030-0863-01	Cross Support .....	1	9	040-0006-33	Screw .....	2
2	015-0412-00	Mounting Bracket .....	2	10	015-0002-01	Strain Relief .....	1
3	040-0010-62	Screw .....	4	11	015-0066-02	Power Cord .....	1
4	015-0437-03	Capacitor .....	2	12	015-0002-02	Strain Relief .....	1
5	015-0413-01	Capacitor Cap .....	2	13	015-0001-00	Wire Clamp .....	2
6	015-0009-01	Terminal Board .....	1	14	040-0010-12	Screw .....	1
7	040-0010-47	Screw .....	1	15	•	•Footswitch (Refer to "Footswitch Com- ponents" Elsewhere) .....	Ref.
8	045-0001-31	Lock Washer .....	1				

**Always Specify Model & Serial Number**



# Cross Support

## SECTION VI PARTS LIST

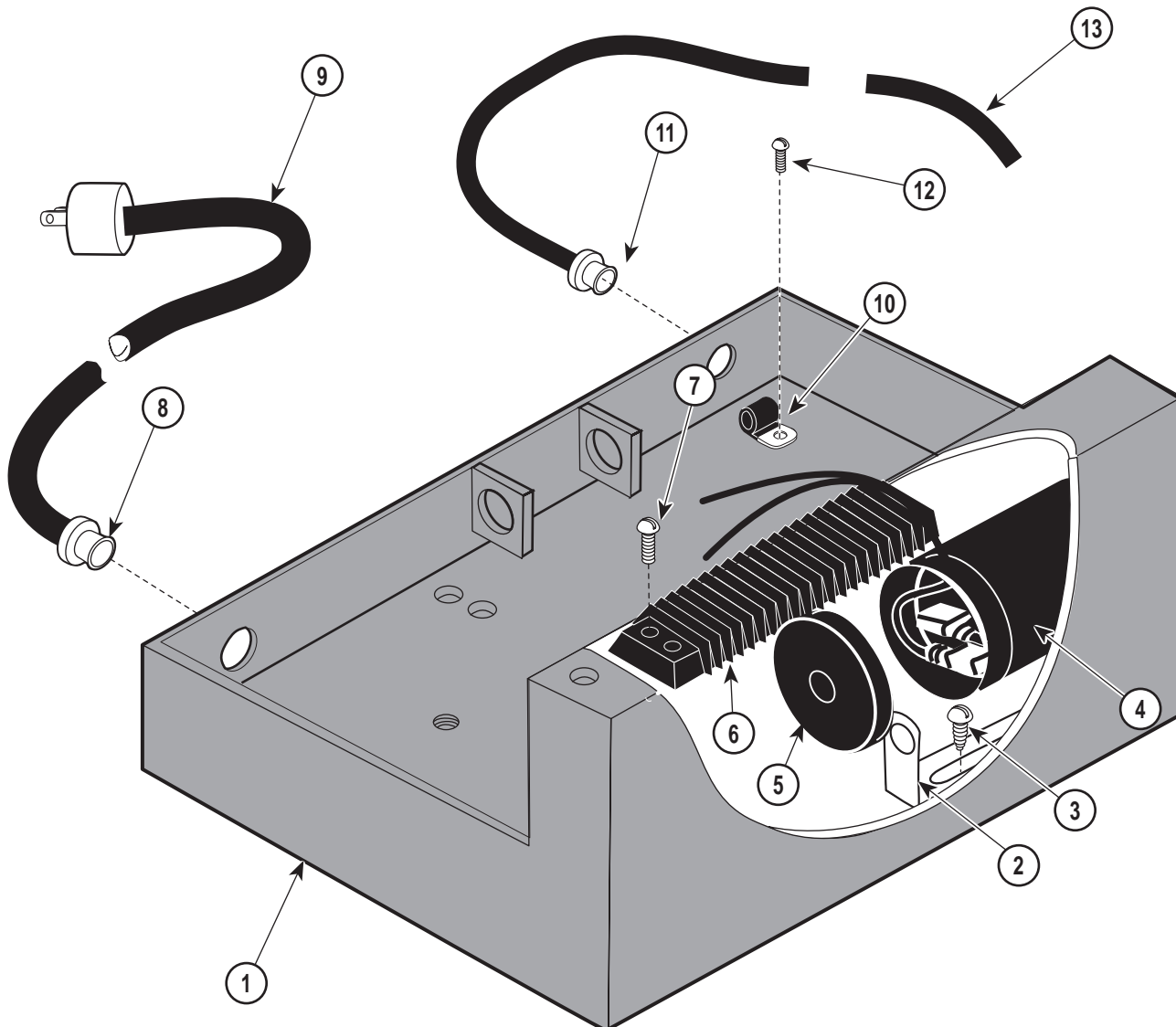

MA306100

**Used on 413 Units with Serial Numbers:**  
**BK 3408 Thru Present      V 1956 Thru Present**  
**FH1004 Thru Present      DT1000 Thru Present**

Item	Part No.	Description	Qty.	Item	Part No.	Description	Qty.
1	050-4020-00	Cross Support .....	1	9	040-0006-33	Screw .....	2
2	015-0412-00	Mounting Bracket .....	2	10	015-0002-01	Strain Relief .....	1
3	040-0010-62	Screw .....	4	11	015-0066-02	Power Cord .....	1
4	015-0437-03	Capacitor .....	2	12	015-0002-02	Strain Relief .....	1
5	015-0413-01	Capacitor Cap .....	2	13	015-0001-00	Wire Clamp .....	2
6	015-0009-01	Terminal Board .....	1	14	040-0010-12	Screw .....	1
7	040-0010-47	Screw .....	1	15	•	•Footswitch (Refer to "Footswitch Com- ponents" Elsewhere) .....	Ref.
8	045-0001-31	Lock Washer .....	1				

Always Specify Model & Serial Number

# Base Components

# SECTION VI PARTS LIST

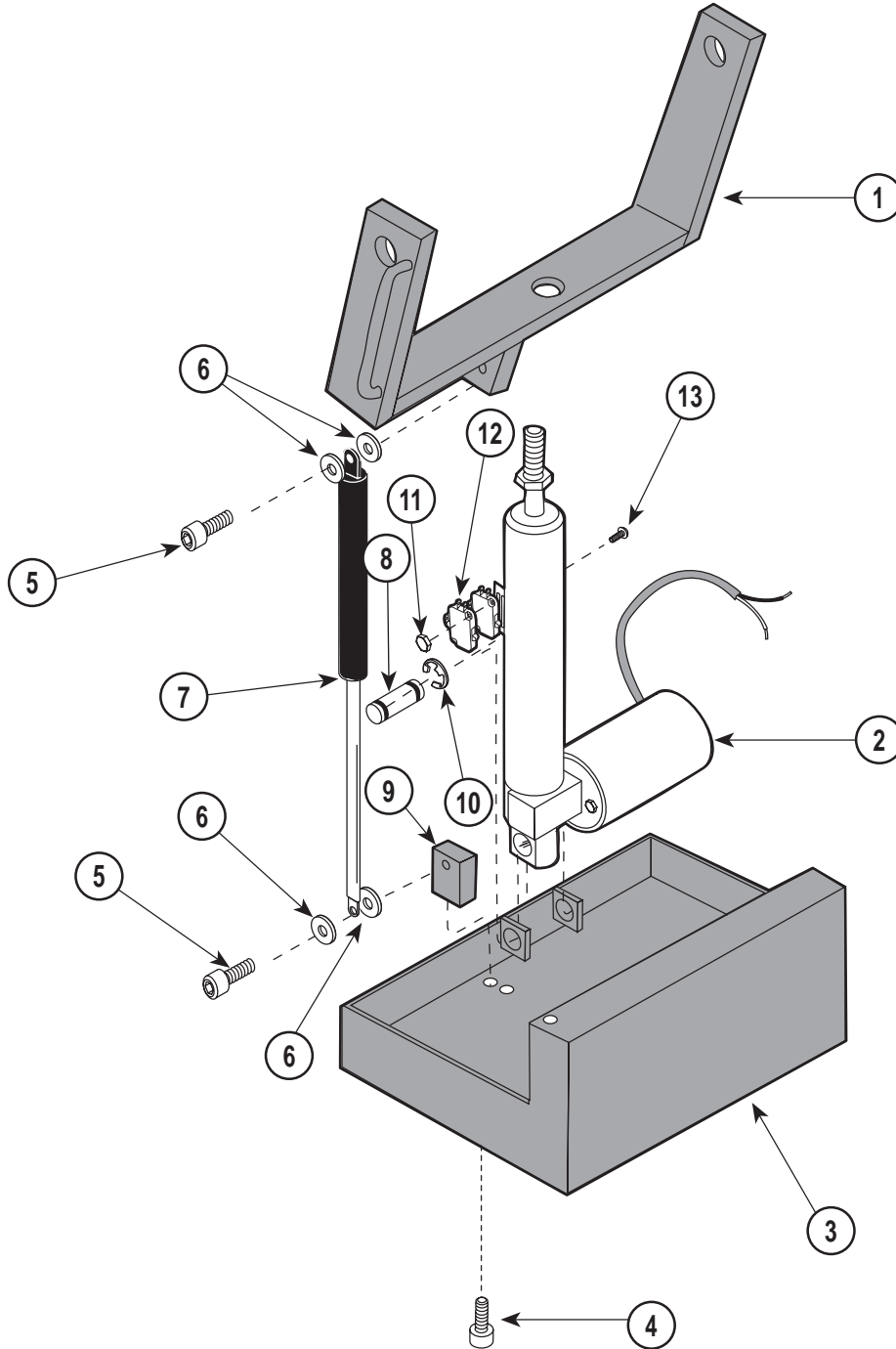

MA306201

**Used on 413 Units with Serial Numbers:  
BK 1000 Thru BK 1271      V 1000 Thru V 1575**

Item	Part No.	Description	Qty.	Item	Part No.	Description	Qty.
1	030-0365-01	Yoke Weldment (Loctite 262) .....	1	7	016-0236-00	Gas Cylinder (1000 N.) .....	1
2		Actuator (Refer to "Actuator Components" Elsewhere) .....	Ref.	8	042-0048-00	Clevis Pin .....	1
3		Cross Support (Refer to "Cross Support" Elsewhere) .....	Ref.	9	051-0449-00	Bottom Spring Mount .....	1
4	040-0312-25	Bolt (Whizlock) .....	1	10	042-0007-02	E-Ring .....	2
5	042-0014-06	Shoulder Bolt .....	2	11	041-0004-01	Nut .....	2
6	045-0001-49	Washer .....	4	12	015-0430-00	Switch .....	2
				13	040-0004-07	Screw .....	2

**Always Specify Model & Serial Number**

# Base Components

# SECTION VI PARTS LIST

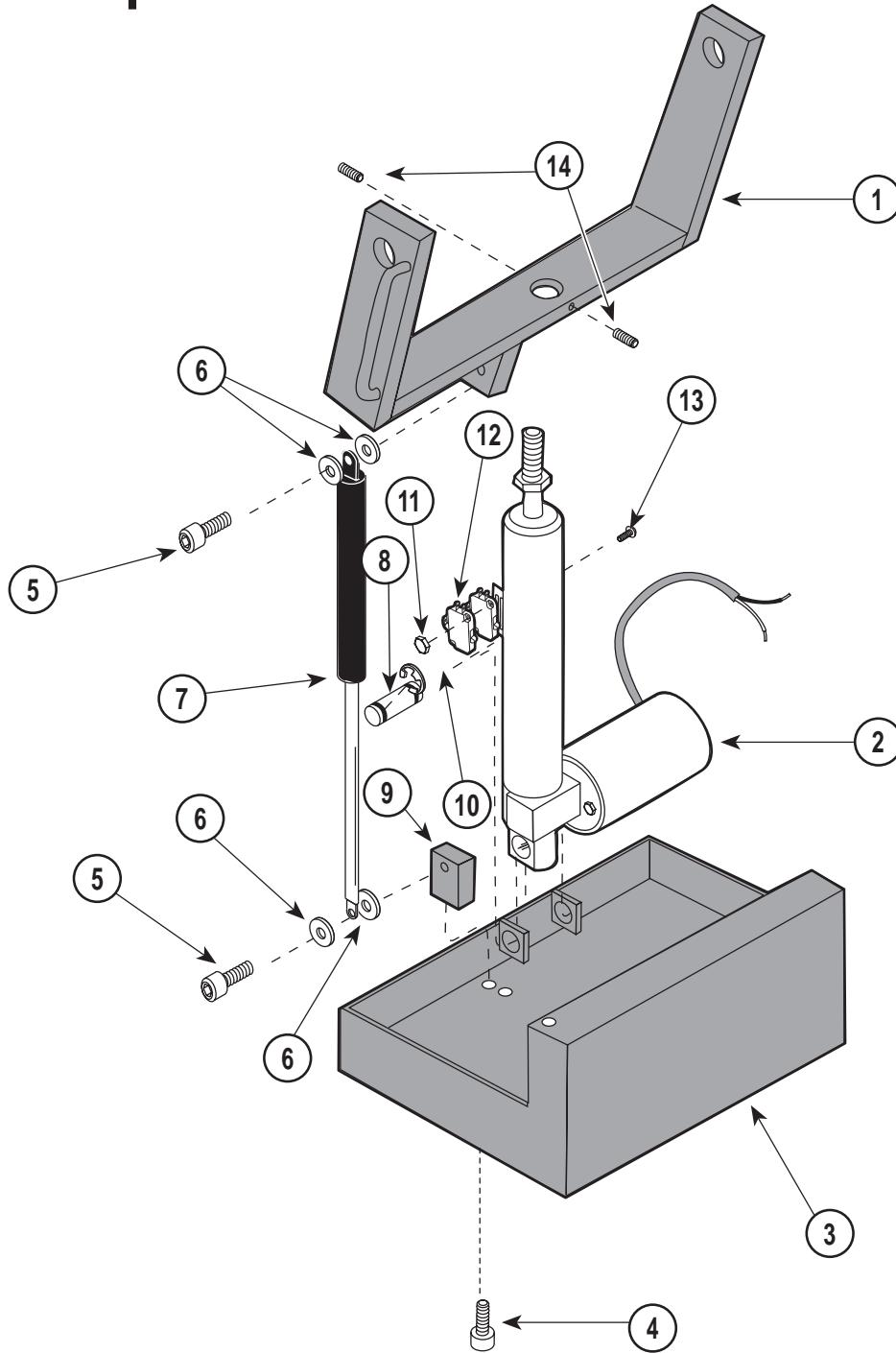

MA306200

**Used on 413 Units with Serial Numbers:  
BK 1272 Thru BK 2512      V 1576 Thru V 1804**

Item	Part No.	Description	Qty.	Item	Part No.	Description	Qty.
1	030-0591-00	Yoke Weldment .....	1	7	016-0236-00	Gas Cylinder (1000 N.) .....	1
2		Actuator (Refer to "Actuator Components" Elsewhere) .....	Ref.	8	042-0048-00	Clevis Pin .....	1
3		Cross Support (Refer to "Cross Support" Elsewhere) .....	Ref.	9	051-0449-00	Bottom Spring Mount .....	1
4	040-0312-25	Bolt (Whizlock) .....	1	10	042-0007-02	E-Ring .....	2
5	042-0014-06	Shoulder Bolt .....	2	11	041-0004-01	Nut .....	2
6	045-0001-49	Washer .....	4	12	015-0430-00	Switch .....	2
				13	040-0004-07	Screw .....	2
				14	040-0250-60	Set Screw .....	2

**Always Specify Model & Serial Number**

# Base Components

# SECTION VI PARTS LIST

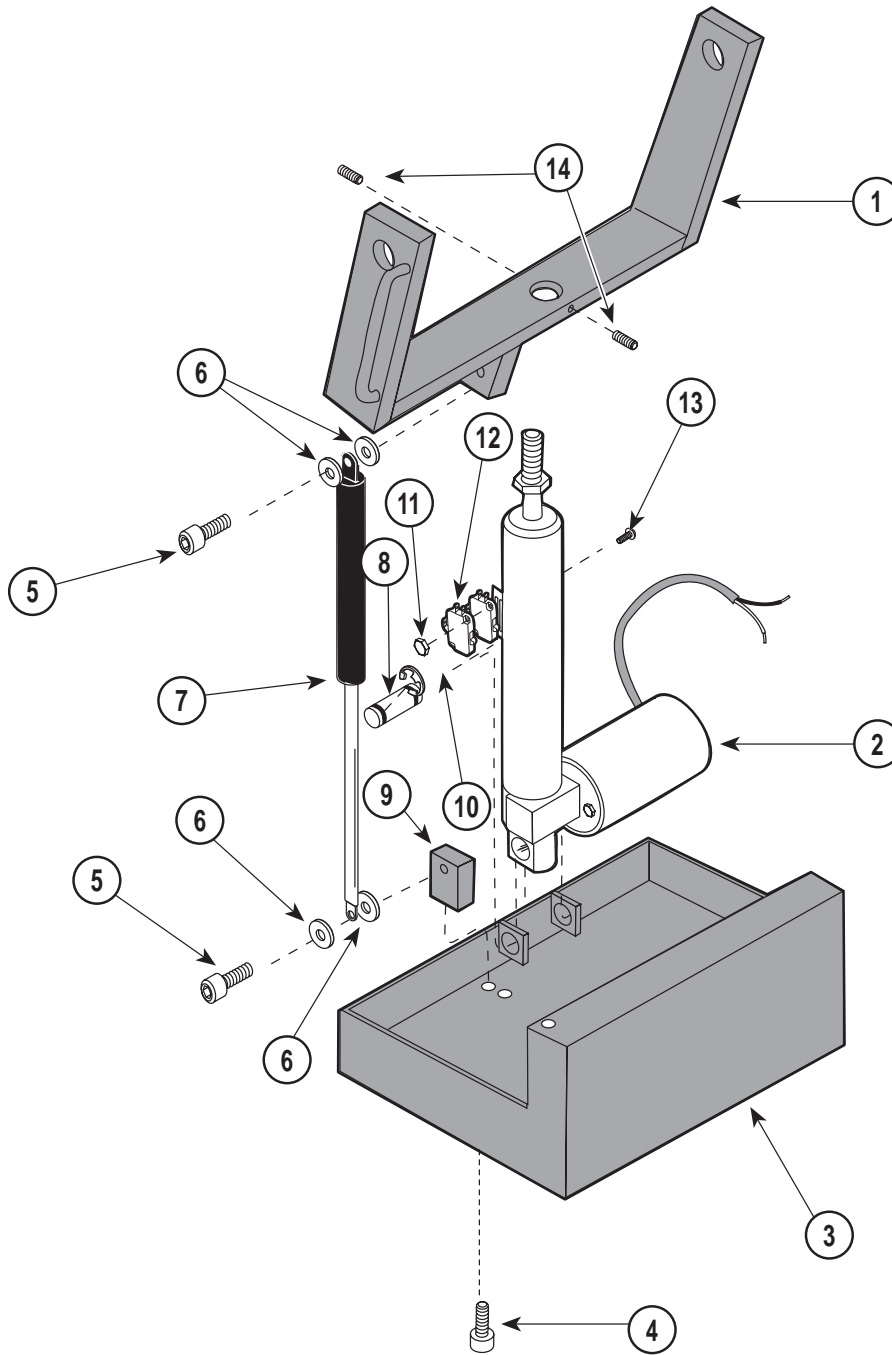

MA306200

**Used on Units with Serial Numbers BK1272 thru BK3547,  
V1576 thru V1991 and FH1000 thru FH1011**

Item	Part No.	Description	Qty.	Item	Part No.	Description	Qty.
1	030-0591-01	Yoke Weldment .....	1	7	016-0236-00	Gas Cylinder (1000 N.) .....	1
2		Actuator (Refer to "Actuator Components" Elsewhere) .....	Ref.	8	042-0048-00	Clevis Pin .....	1
3		Cross Support (Refer to "Cross Support" Elsewhere) .....	Ref.	9	051-0449-00	Bottom Spring Mount .....	1
4	040-0312-25	Bolt (Whizlock) .....	1	10	042-0007-02	E-Ring .....	2
5	042-0014-06	Shoulder Bolt .....	2	11	041-0004-01	Nut .....	2
6	045-0001-49	Washer .....	4	12	015-0430-00	Switch .....	2
				13	040-0004-07	Screw .....	2
				14	040-0250-60	Set Screw .....	2

**Always Specify Model & Serial Number**

# Base Components

# SECTION VI PARTS LIST

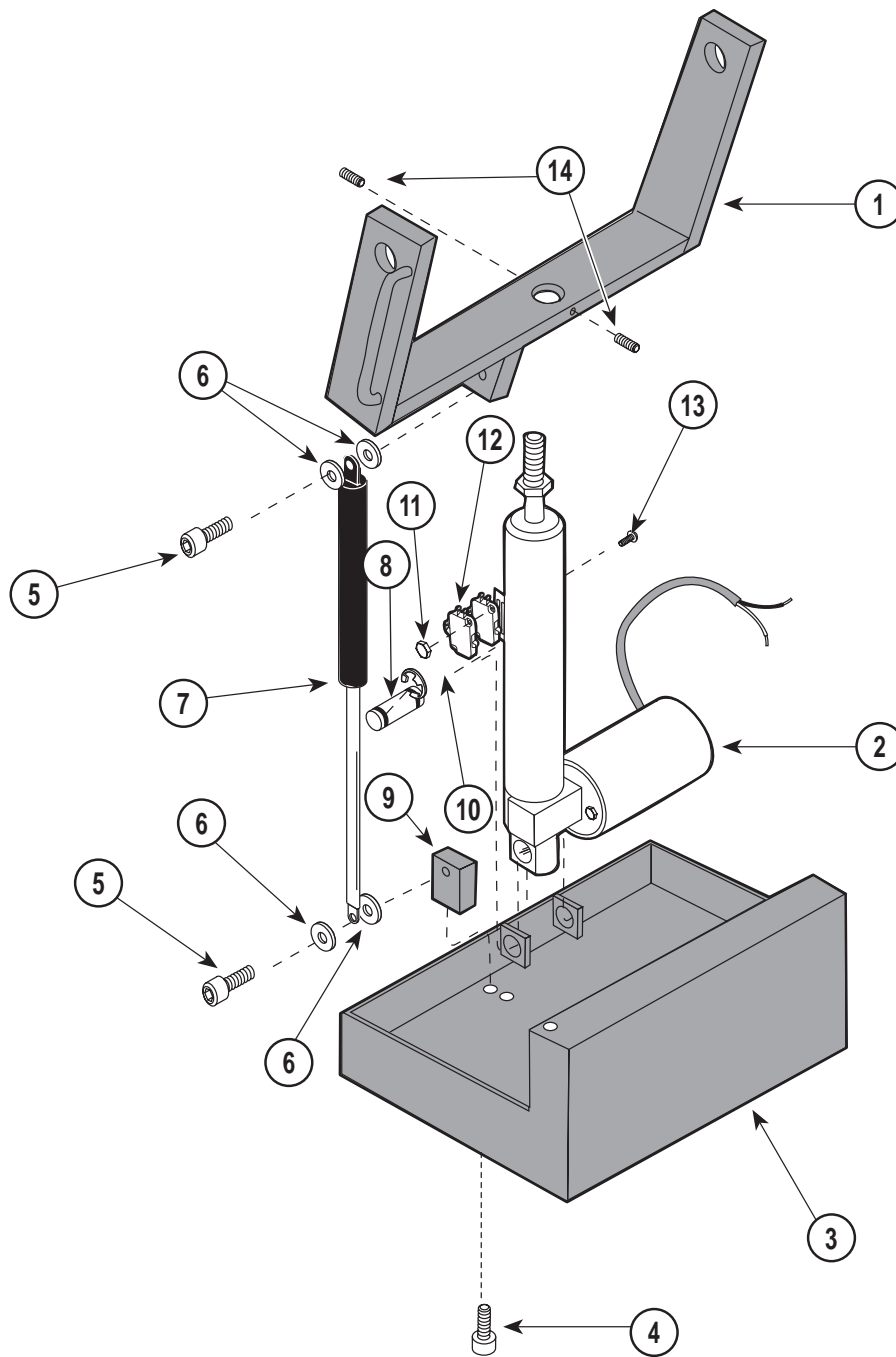

MA306200

**Used on Units with Serial Numbers BK3548, V1992, DT1000  
and FH1012 thru Present**

Item	Part No.	Description	Qty.	Item	Part No.	Description	Qty.
1	030-0591-01	Yoke Weldment .....	1	7	016-0236-00	Gas Cylinder (1000 N.) .....	1
2		Actuator (Refer to "Actuator Components Elsewhere) .....	Ref.	8	042-0048-00	Clevis Pin .....	1
3		Cross Support (Refer to "Cross Support" Elsewhere) .....	Ref.	9	051-0449-00	Bottom Spring Mount .....	1
4	040-0312-25	Bolt (Whizlock) .....	1	10	042-0007-02	E-Ring .....	2
5	042-0014-06	Shoulder Bolt .....	2	11	041-0004-01	Nut .....	2
6	045-0001-49	Washer .....	4	12	015-0430-00	Switch .....	2
				13	040-0004-07	Screw .....	2
				14	040-0250-60	Set Screw .....	2

**Always Specify Model & Serial Number**

# Base Actuator

## SECTION VI PARTS LIST

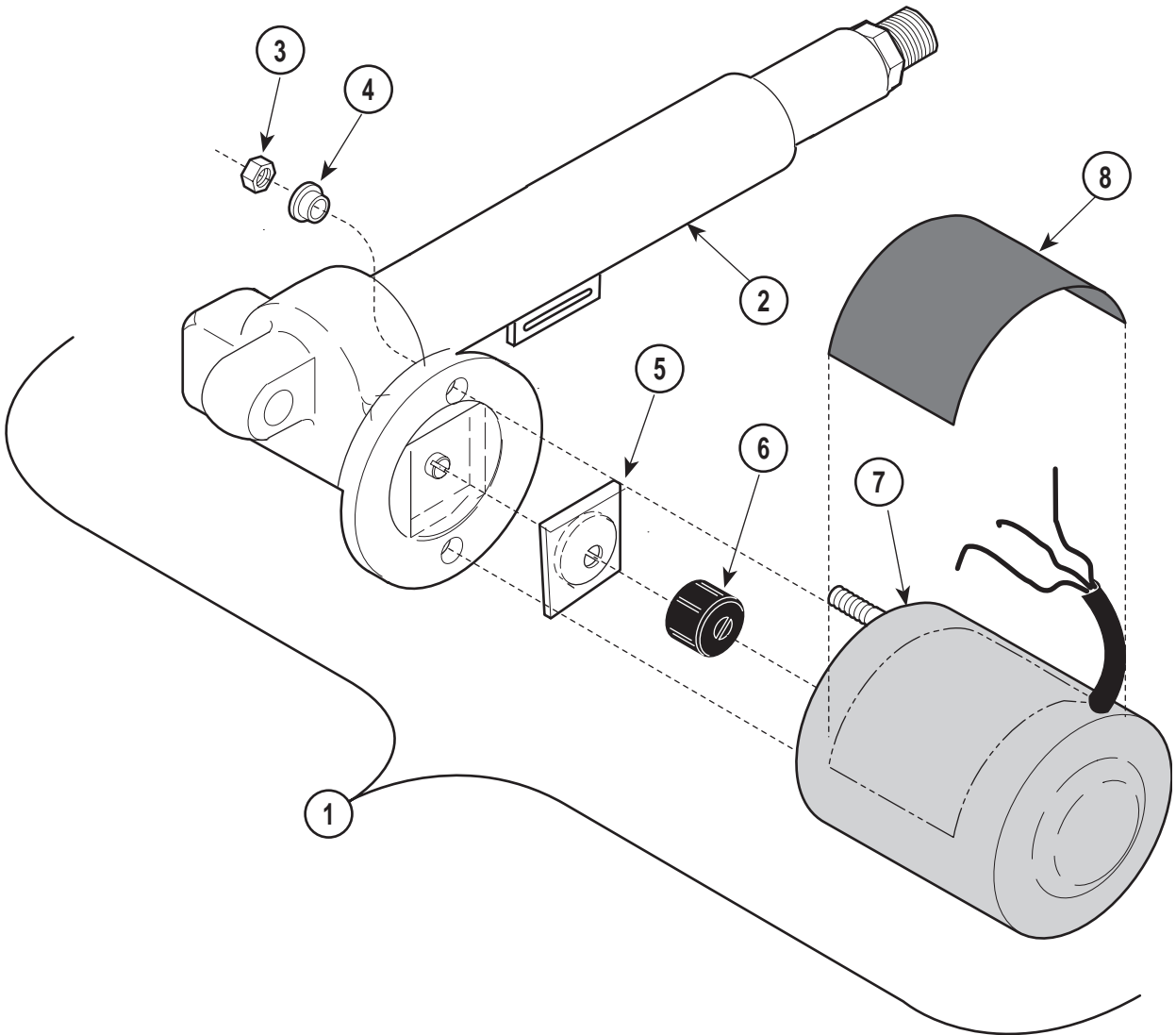

MA306601

**Used on 413 Units with Serial Numbers:  
BK 1000 Thru BK1271      V 1000 Thru V 1575**

Item	Part No.	Description	Qty.	Item	Part No.	Description	Qty.
1	016-0214-00	Base Actuator Assembly - Domestic .....	1	4	•053-0198-00	•Shoulder Washer .....	2
		( Includes Items 2 - 8) .....	1	5	•016-0237-00	•Actuator Brake .....	1
	016-0214-01	Base Actuator Assembly - Export .....	1	6	•016-0509-00	•Motor Coupler .....	1
		(Includes Items 2 - 8) .....	1	7	•002-0574-00	•Actuator Motor (Domestic) .....	1
2	•016-0214-04	•Base Actuator-(Less Motor) .....	1		•002-0574-01	•Actuator Motor (Export) .....	1
3	•	•Nut .....	2	8	061-0135-00	Caution Label .....	1

**Always Specify Model & Serial Number**

# Base Actuator

## SECTION VI PARTS LIST

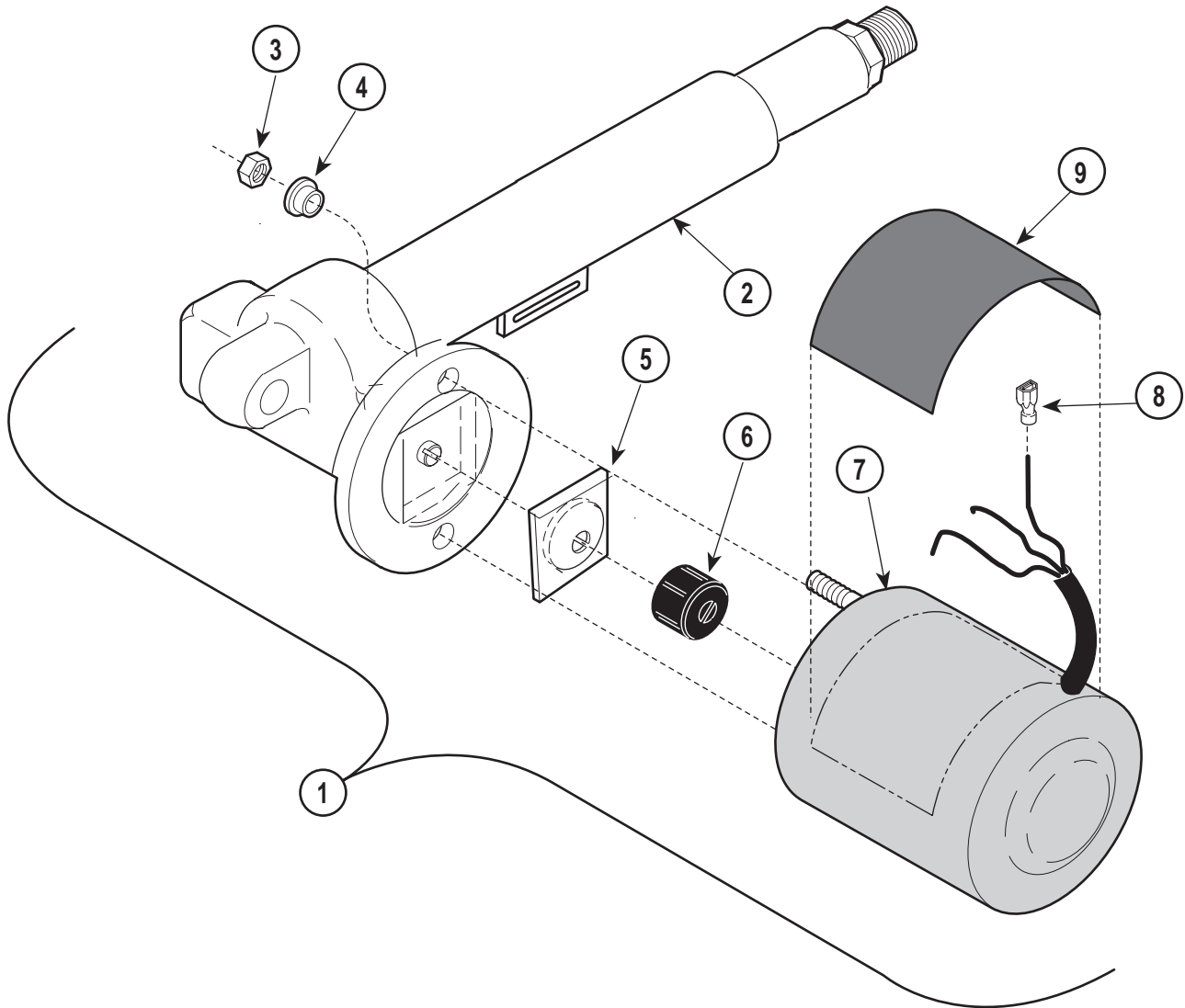

MA306600

**Used on Units with Serial Numbers BK1272 thru BK3547,  
V1576 thru V1991 and FH1000 thru FH1011**

Item	Part No.	Description	Qty.	Item	Part No.	Description	Qty.
1	002-0437-00	Base Actuator Assembly Kit - Domestic ...	1	4	• 053-0198-00	• Shoulder Washer .....	2
		( Includes Items 2 - 9) .....	1	5	• 016-0237-00	• Actuator Brake .....	1
	002-0438-00	Base Actuator Assembly Kit- Export .....	1	6	• 016-0509-00	• Motor Coupler .....	1
		( Includes Items 2 - 9) .....	1	7	• 002-0574-00	• Actuator Motor (Domestic) .....	1
2	• 016-0347-02	• Base Actuator-Domestic (Less Motor) .	1		• 002-0574-01	• Actuator Motor (Export) .....	1
	• 016-0347-01	• Base Actuator-Export (Less Motor) .....	1	8	• 015-0018-03	• Terminal .....	3
3	•	• Nut .....	2	9	061-0135-00	Caution Label .....	1

**Always Specify Model & Serial Number**

# Base Actuator

## SECTION VI PARTS LIST

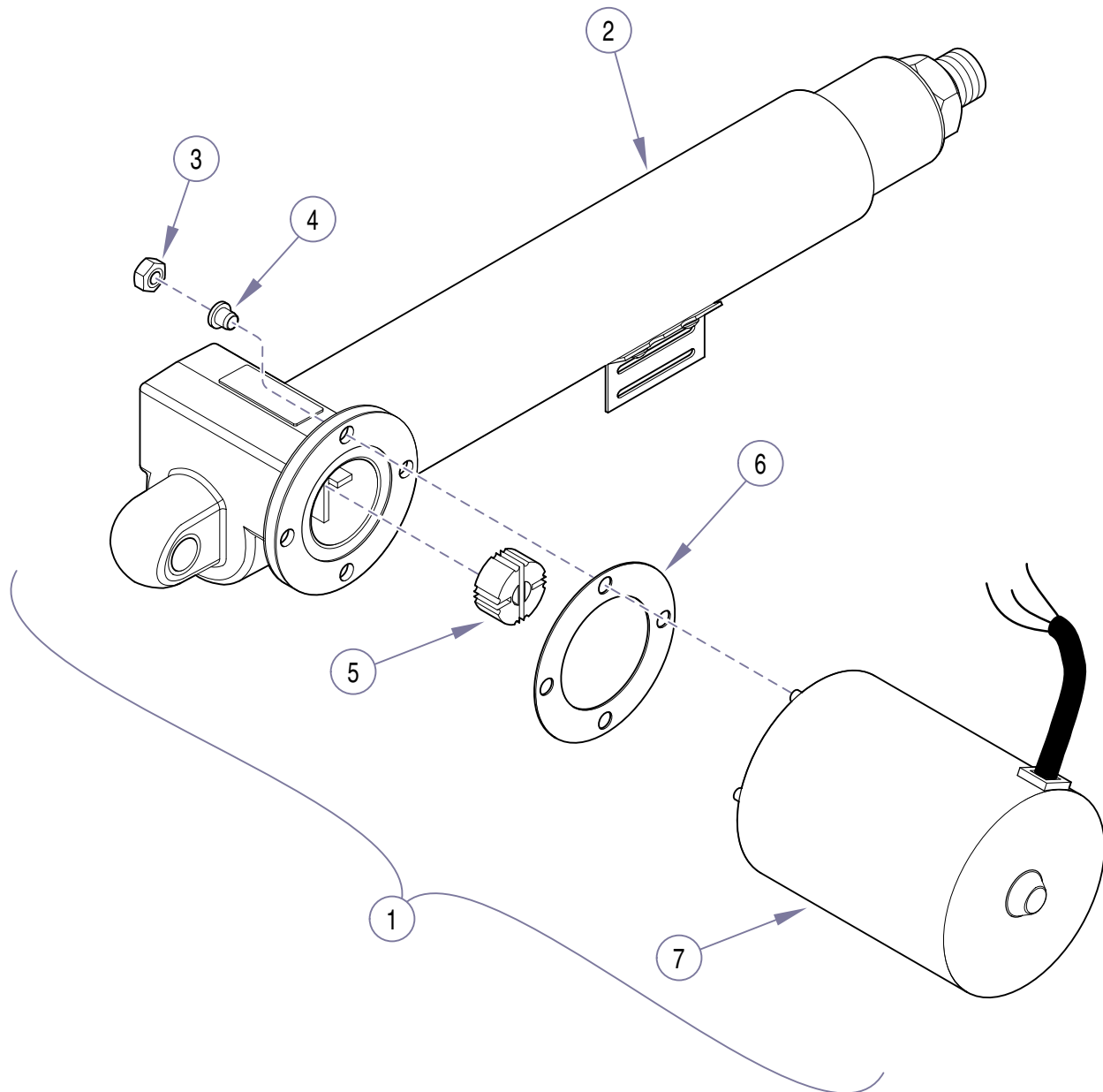

MA6039001

**Used on Units with Serial Numbers BK3548, V1992, DT1000  
and FH1012 thru Present**

Item	Part No.	Description	Qty.	Item	Part No.	Description	Qty.
1	002-0437-00	Base Actuator Assembly Kit - Domestic ... ( Includes Items 2 - 7 ) .....	1	4	• 053-0198-00	• Shoulder Washer .....	3
	002-0438-00	Base Actuator Assembly Kit- Export .....	1	5	• 016-0662-00	• Motor Coupler .....	1
		( Includes Items 2 - 7 ) .....	1	6	• 053-0834-00	• Isolation Washer .....	1
2	•	• Base Actuator-(Less Motor)(Not Available) .....	Ref.	7	• 015-1085-00	• Actuator Motor (Domestic) .....	1
3	• 041-0010-10	• Nut .....	3		• 015-1085-01	• Actuator Motor (Export) .....	1

**Always Specify Model & Serial Number**



# Base and Panels

# SECTION VI PARTS LIST

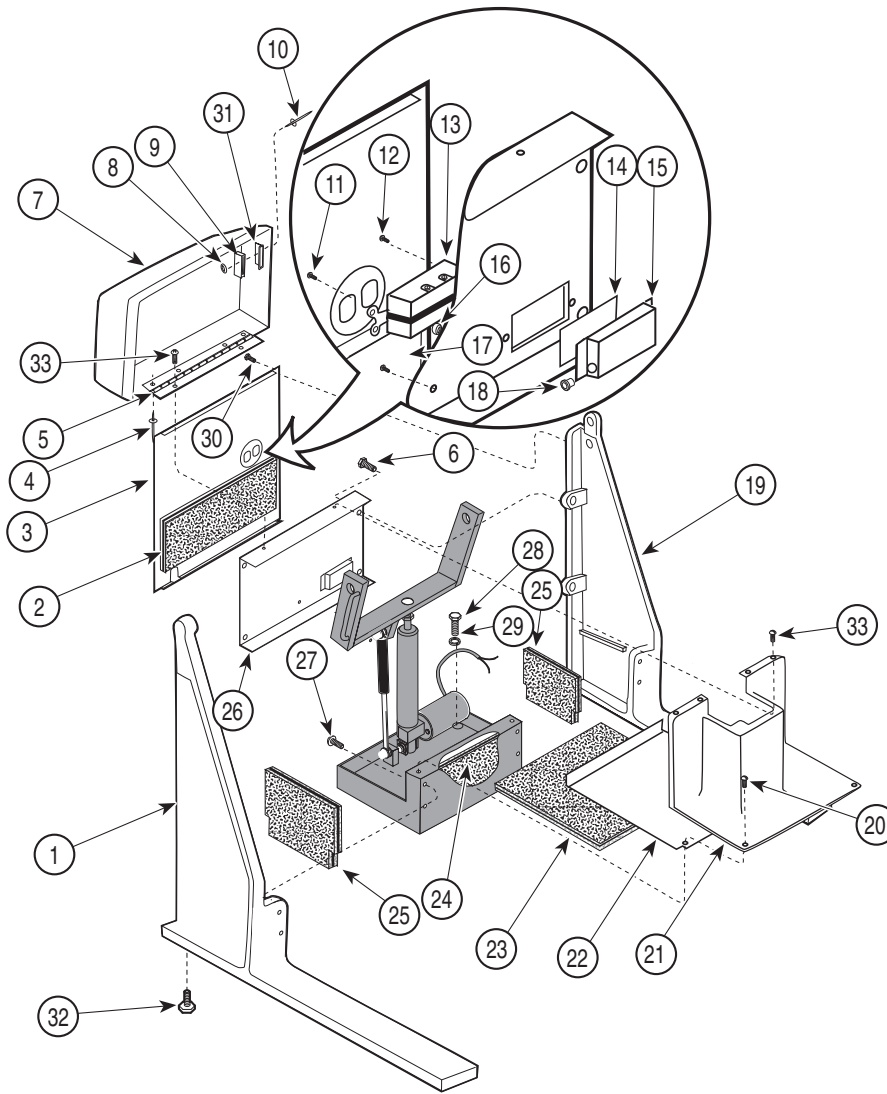

MA306304

**Used on 413 Units with Serial Numbers:  
BK 1000 thru BK 2512 V 1000 thru V 1804**

Item	Part No.	Description	Qty.	Item	Part No.	Description	Qty.
1	020-0036-00	R.H. Side Upright .....	1	17	040-0010-47	Screw .....	2
2	054-0087-00	Sound Damp Back .....	1	18	053-0068-00	Snap Bushing .....	1
3	050-1053-01	Back Shroud w/Receptacle .....	1	19	020-0036-01	L.H. Side Upright .....	1
4	042-0010-02	Pop Rivet .....	3	20	040-0006-33	Screw .....	2
5	N.L.A.	Hinge .....	1	21	053-0280-00	Base Cover .....	1
6	040-0375-00	Bolt .....	4	22	050-1372-00	Inner Shroud .....	1
7	053-0183-01	Pan Cover .....	1	23	054-0086-00	Sound Damp Top .....	1
8	045-0001-50	Washer (newer units only) .....	4	24	054-0085-00	Sound Damp Front .....	1
9	016-0092-00	Magnet (attached w/adhesive on older units) .....	2	25	054-0088-00	Sound Damp Sides .....	2
10	042-0010-01	Pop Rivet (newer units only) .....	4	26	050-1042-00	Channel Back .....	1
11	040-0006-23	Screw .....	1	27	040-0250-88	Screw w/whizlock .....	4
12	040-0006-34	Screw .....	2	28	040-0500-00	Bolt .....	6
13	015-0083-01	Receptacle .....	1	29	045-0001-33	Washer .....	6
14	053-0092-00	Insulator .....	1	30	040-0008-06	Screw .....	16
15	050-1068-00	Wire Cover .....	1	31	016-0363-00	Mounting Bracket (newer units only) .....	2
16	015-0718-00	Spacer .....	2	32	016-0001-00	Leveling Screw .....	4
				33	040-0008-06	Screw .....	6

N.L.A. Denotes "No Longer Available"  
Always Specify Model & Serial Number

# Base and Panels

# SECTION VI PARTS LIST

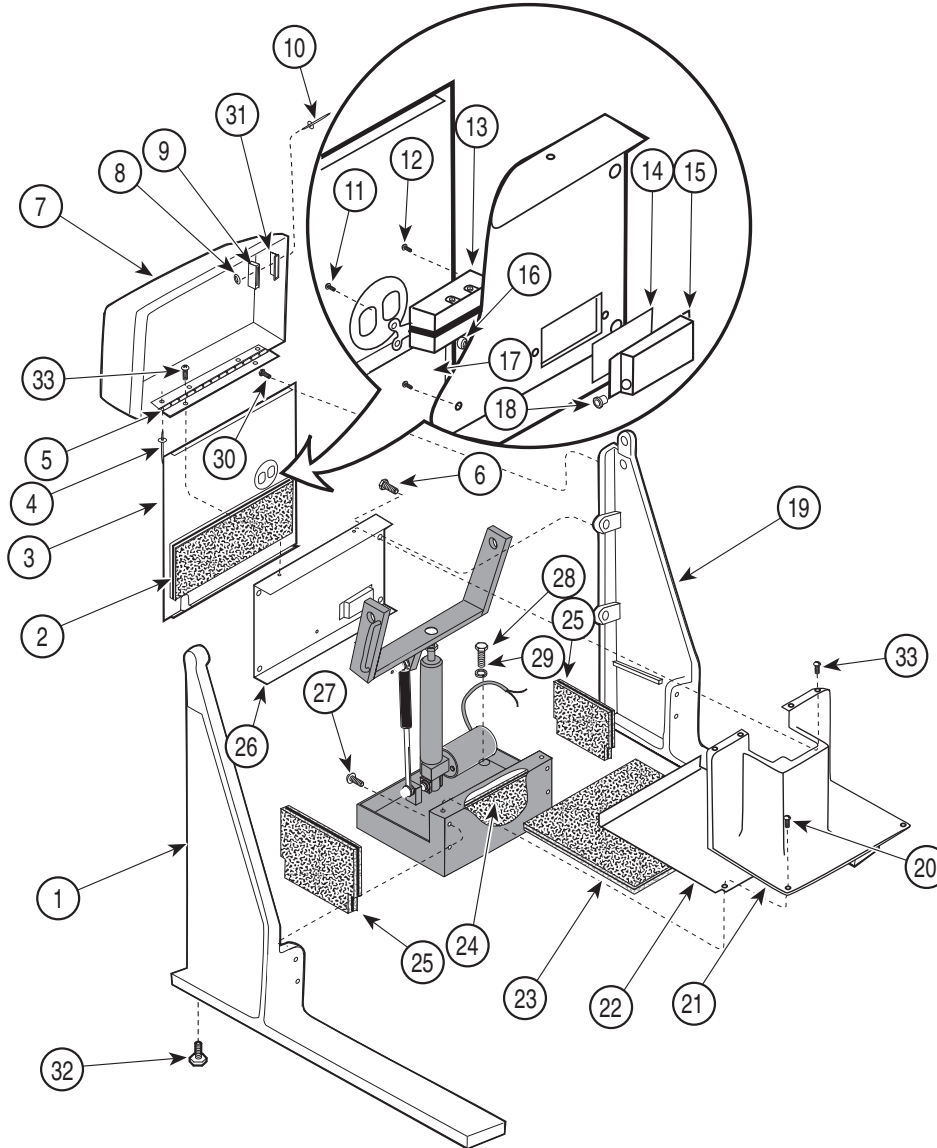

MA306304i

**Used on 413 Units with Serial Numbers:  
BK2513 Thru BK3219      V 1805 Thru 1935  
FH 1000 Thru FH1001**

Item	Part No.	Description	Qty.	Item	Part No.	Description	Qty.
1	020-0036-06	R.H. Side Upright .....	1	18	053-0068-00	Snap Bushing .....	1
2	054-0087-00	Sound Damp Back .....	1	19	020-0036-07	L.H. Side Upright .....	1
3	050-1053-02	Back Shroud w/Receptacle .....	1	20	040-0006-33	Screw .....	2
4	042-0010-02	Pop Rivet .....	3	21	053-0280-00	Base Cover .....	1
5	N.L.A.	Hinge .....	1	22	050-1372-00	Inner Shroud .....	1
6	040-0375-00	Bolt .....	4	23	054-0086-00	Sound Damp Top .....	1
7	053-0183-01	Pan Cover .....	1	24	054-0085-00	Sound Damp Front .....	1
8	045-0001-50	Washer .....	4	25	054-0088-00	Sound Damp Sides .....	2
9	016-0092-00	Magnet .....	2	26	050-1042-00	Channel Back .....	1
10	042-0010-01	Pop Rivet .....	4	27	040-0250-88	Screw w/whizlock .....	4
11	040-0006-23	Screw .....	1	28	040-0500-00	Bolt .....	6
12	040-0006-34	Screw .....	2	29	045-0001-33	Washer .....	6
13	015-0083-01	Receptacle .....	1	30	040-0008-06	Screw .....	16
14	053-0092-00	Insulator .....	1	31	016-0363-00	Magnet Mounting Bracket .....	2
15	050-1068-00	Wire Cover .....	1	32	016-0001-00	Leveling Screw .....	4
16	015-0718-00	Spacer .....	2	33	040-0008-06	Screw .....	4
17	040-0010-47	Screw .....	2				

N.L.A. Denotes "No Longer Available"  
Always Specify Model & Serial Number

# Base and Panels

# SECTION VI PARTS LIST

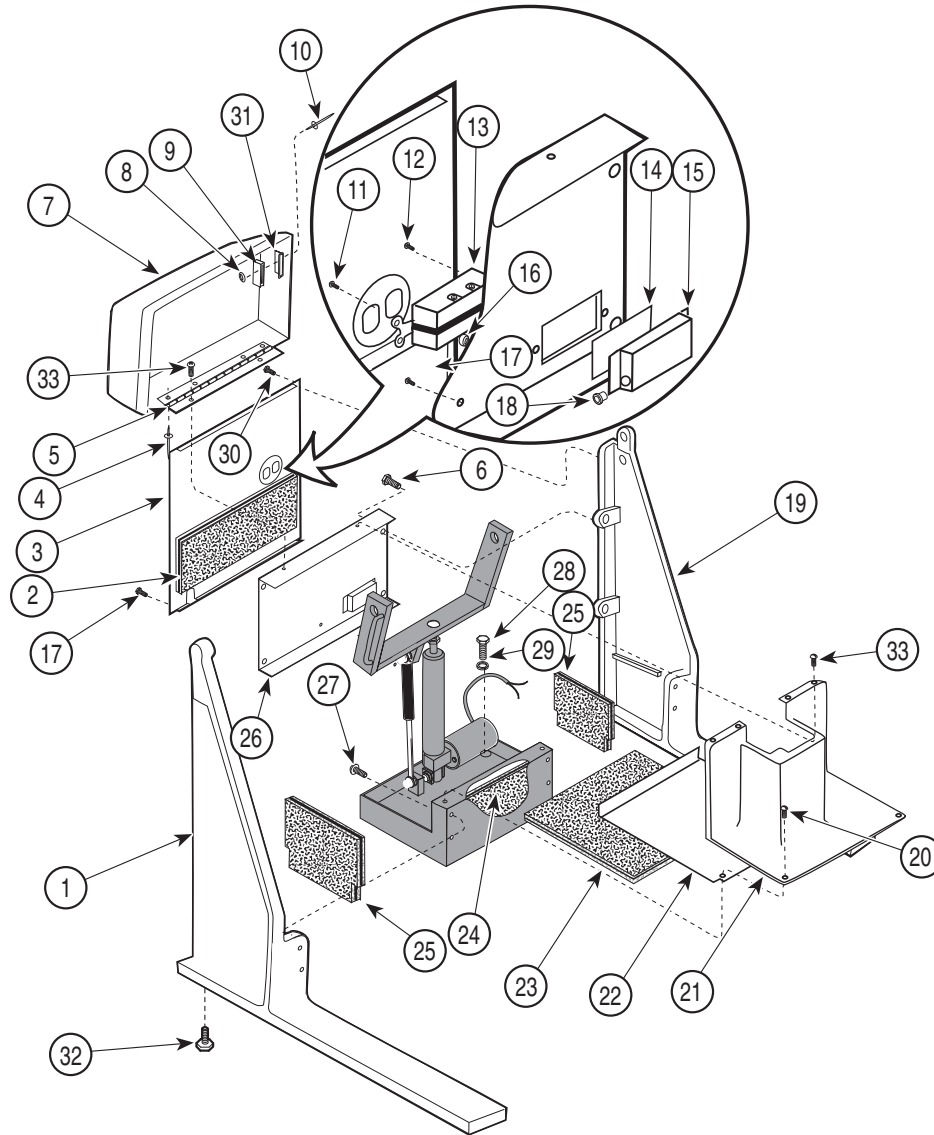

MA306305i

**Used on 413 Units with Serial Numbers:**  
**BK 3220 Thru Present      V 1936 Thru Present**  
**FH 1002 Thru Present      DT 1000 Thru Present**

Item	Part No.	Description	Qty.	Item	Part No.	Description	Qty.
1	020-0036-08	R.H. Side Upright .....	1	18	053-0068-00	Snap Bushing .....	1
2	054-0087-00	Sound Damp Back .....	1	19	020-0036-09	L.H. Side Upright .....	1
3	050-3784-00	Back Shroud w/Receptacle .....	1	20	040-0006-33	Screw .....	2
4	042-0010-02	Pop Rivet .....	3	21	053-0280-00	Base Cover .....	1
5	N.L.A.	Hinge .....	1	22	050-1372-00	Inner Shroud .....	1
6	040-0375-00	Bolt .....	4	23	054-0086-00	Sound Damp Top .....	1
7	053-0183-01	Pan Cover .....	1	24	054-0085-00	Sound Damp Front .....	1
8	045-0001-50	Washer .....	4	25	054-0088-00	Sound Damp Sides .....	2
9	016-0092-00	Magnet .....	2	26	050-1042-00	Channel Back .....	1
10	042-0010-01	Pop Rivet .....	4	27	040-0250-88	Screw w/whizlock .....	4
11	040-0006-23	Screw .....	1	28	040-0500-00	Bolt .....	6
12	040-0006-34	Screw .....	2	29	045-0001-33	Washer .....	6
13	015-0083-01	Receptacle .....	1	30	040-0008-06	Screw .....	10
14	053-0092-00	Insulator .....	1	31	016-0363-00	Magnet Mounting Bracket .....	2
15	050-1068-00	Wire Cover .....	1	32	016-0001-00	Leveling Screw .....	4
16	015-0718-00	Spacer .....	2	33	040-0008-06	Screw .....	4
17	040-0010-47	Screw .....	22				

N.L.A. Denotes "No Longer Available"  
**Always Specify Model & Serial Number**

# Linkage Assembly

## SECTION VI PARTS LIST

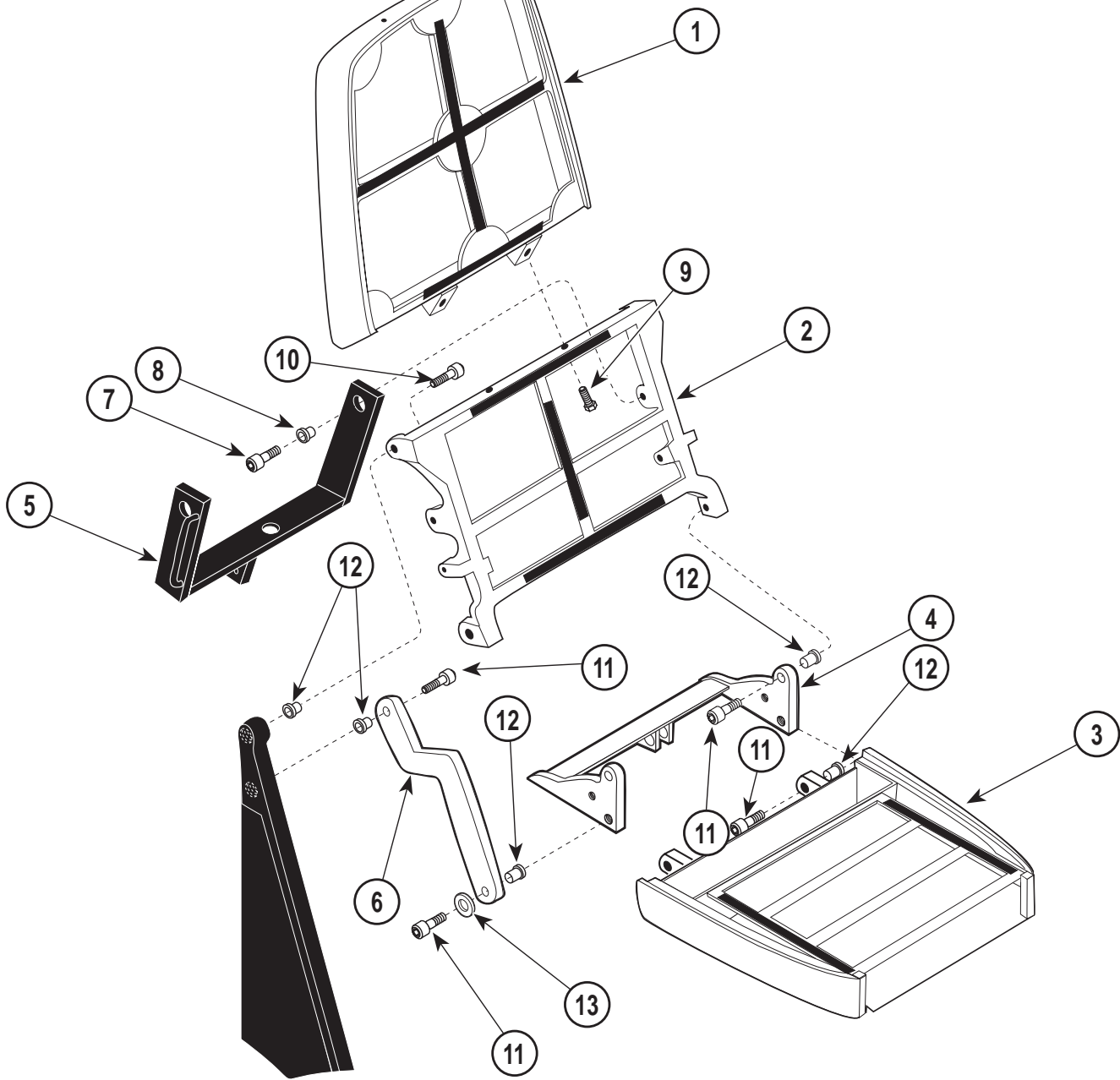

MA306501

**Used on 413 Units with Serial Numbers:  
BK 1000 Thru BK 1271    V 1000 Thru V 1575**

Item	Part No.	Description	Qty.	Item	Part No.	Description	Qty.
1		Upper Back (Refer to "Main Frame Section" Elsewhere) .....	Ref.	6	050-1054-00	Link .....	2
2		Lower Back (Refer to "Main Frame Section" Elsewhere) .....	Ref.	7	042-0014-00	Shoulder Bolt .....	2
3		Seat Assembly (Refer to "Main Frame Section" Elsewhere) .....	Ref.	8	016-0076-00	Bushing .....	2
4	030-0364-00	Pivot Frame .....	1	9	040-0500-01	Bolt .....	2
5		Yoke Weldment (Refer to "Base Components" Elsewhere) .....	Ref.f	10	042-0014-11	Shoulder Bolt .....	2
				11	042-0014-05	Shoulder Bolt .....	8
				12	016-0131-04	Flanged Bearing .....	10
				13	045-0001-37	Washer .....	2

**Always Specify Model & Serial Number**

# Linkage Assembly

## SECTION VI PARTS LIST

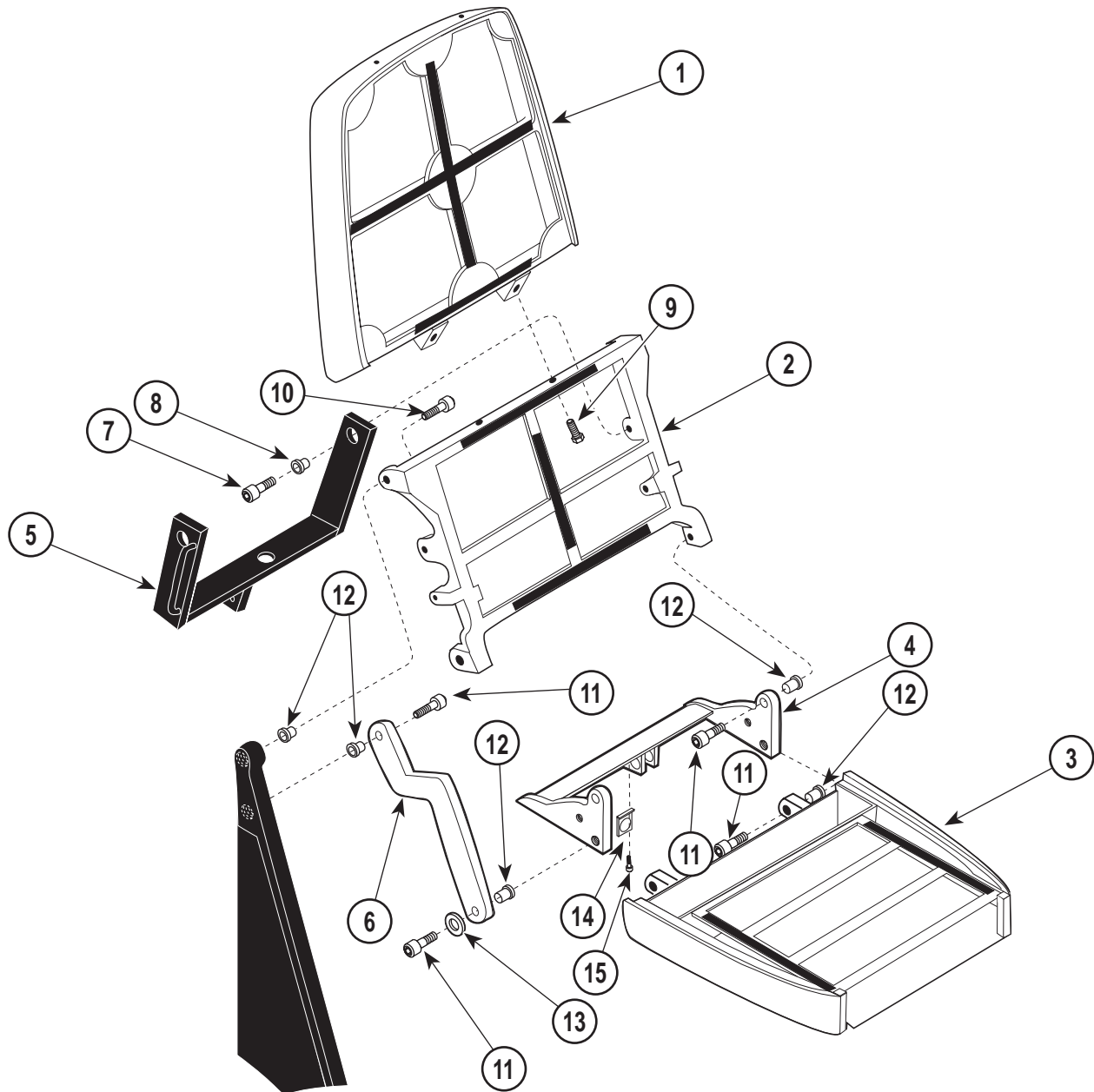

MA306500

**Used on 413 Units with Serial Numbers:  
BK 1272 Thru BK 2512    V 1576 Thru V 1804**

Item	Part No.	Description	Qty.	Item	Part No.	Description	Qty.
1		Upper Back (Refer to "Main Frame Section" Elsewhere) .....	Ref.	7	042-0014-00	Shoulder Bolt .....	2
2		Lower Back (Refer to "Main Frame Section" Elsewhere) .....	Ref.	8	016-0076-00	Bushing .....	2
3		Seat Assembly (Refer to "Main Frame Section" Elsewhere) .....	Ref.	9	040-0500-01	Bolt .....	2
4	030-0585-00	Pivot Frame .....	1	10	042-0014-11	Shoulder Bolt .....	2
5		Yoke Weldment (Refer to "Base Components" Elsewhere) .....	Ref.f	11	042-0014-05	Shoulder Bolt .....	8
6	050-1054-01	Link .....	2	12	016-0131-04	Flanged Bearing .....	10
				13	045-0001-37	Washer .....	2
				14	050-1513-00	Connector Mount .....	1
				15	042-0014-11	Shoulder Bolt .....	2

**Always Specify Model & Serial Number**

# Linkage Assembly

## SECTION VI PARTS LIST

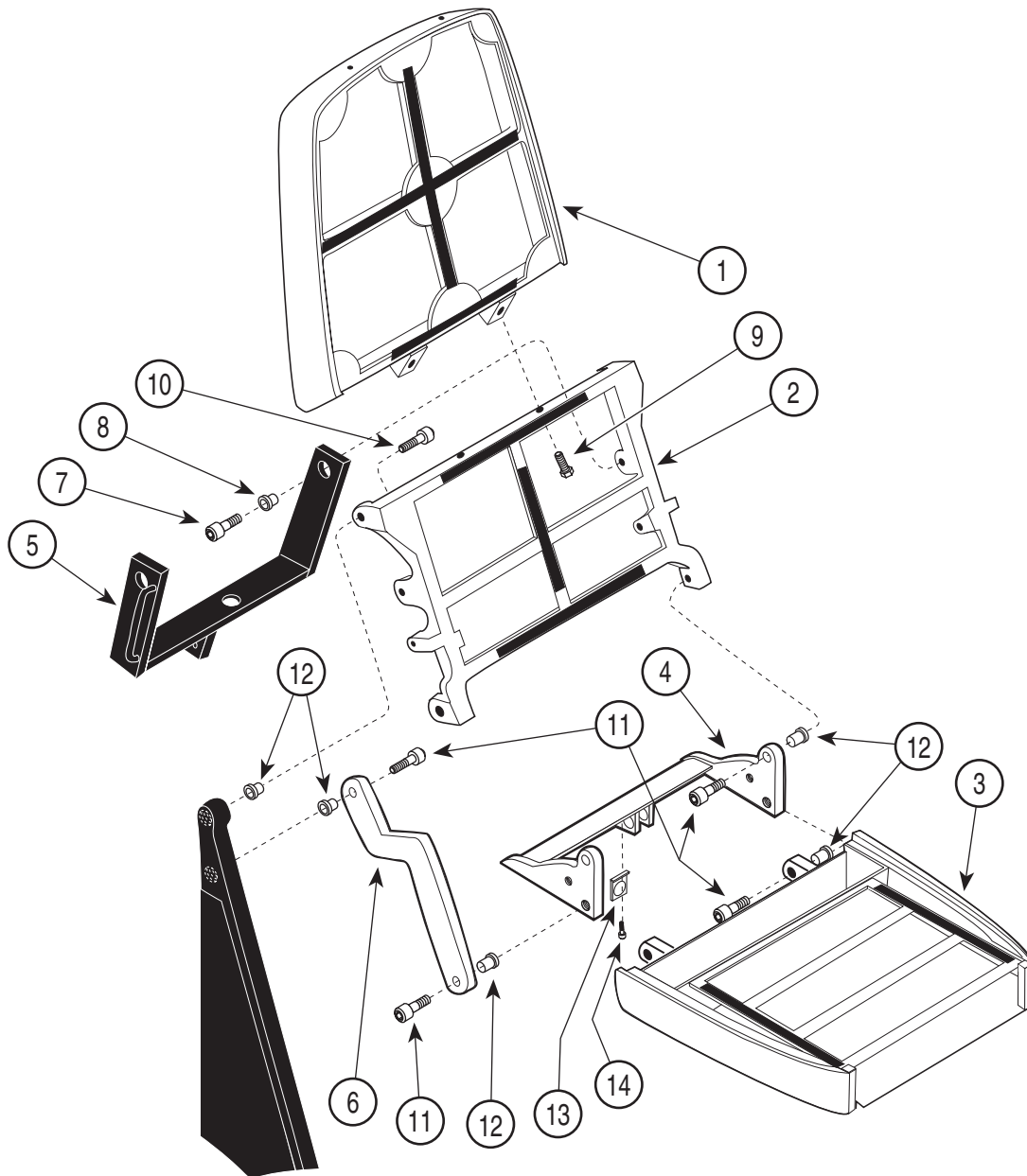

MA481500

**Used on 413 Units with Serial Numbers:  
BK 2513 Thru Present V 1805 Thru Present  
FH 1000 Thru Present**

Item	Part No.	Description	Qty.	Item	Part No.	Description	Qty.
1		Upper Back (Refer to "Main Frame Section" Elsewhere) .....	Ref.	6	050-1054-01	Link .....	2
2		Lower Back (Refer to "Main Frame Section" Elsewhere) .....	Ref.	7	042-0014-00	Shoulder Bolt .....	2
3		Seat Assembly (Refer to "Main Frame Section" Elsewhere) .....	Ref.	8	016-0076-00	Bushing .....	2
4	030-0585-01	Pivot Frame .....	1	9	040-0500-01	Bolt .....	2
5		Yoke Weldment (Refer to "Base Components" Elsewhere) .....	1	10	042-0014-11	Shoulder Bolt .....	2
				11	042-0014-05	Shoulder Bolt .....	8
				12	016-0131-04	Flanged Bearing .....	10
				13	050-1513-00	Connector Mount .....	1
				14	042-0014-11	Shoulder Bolt .....	2

**Always Specify Model & Serial Number**

# Pan Assembly

## SECTION VI PARTS LIST

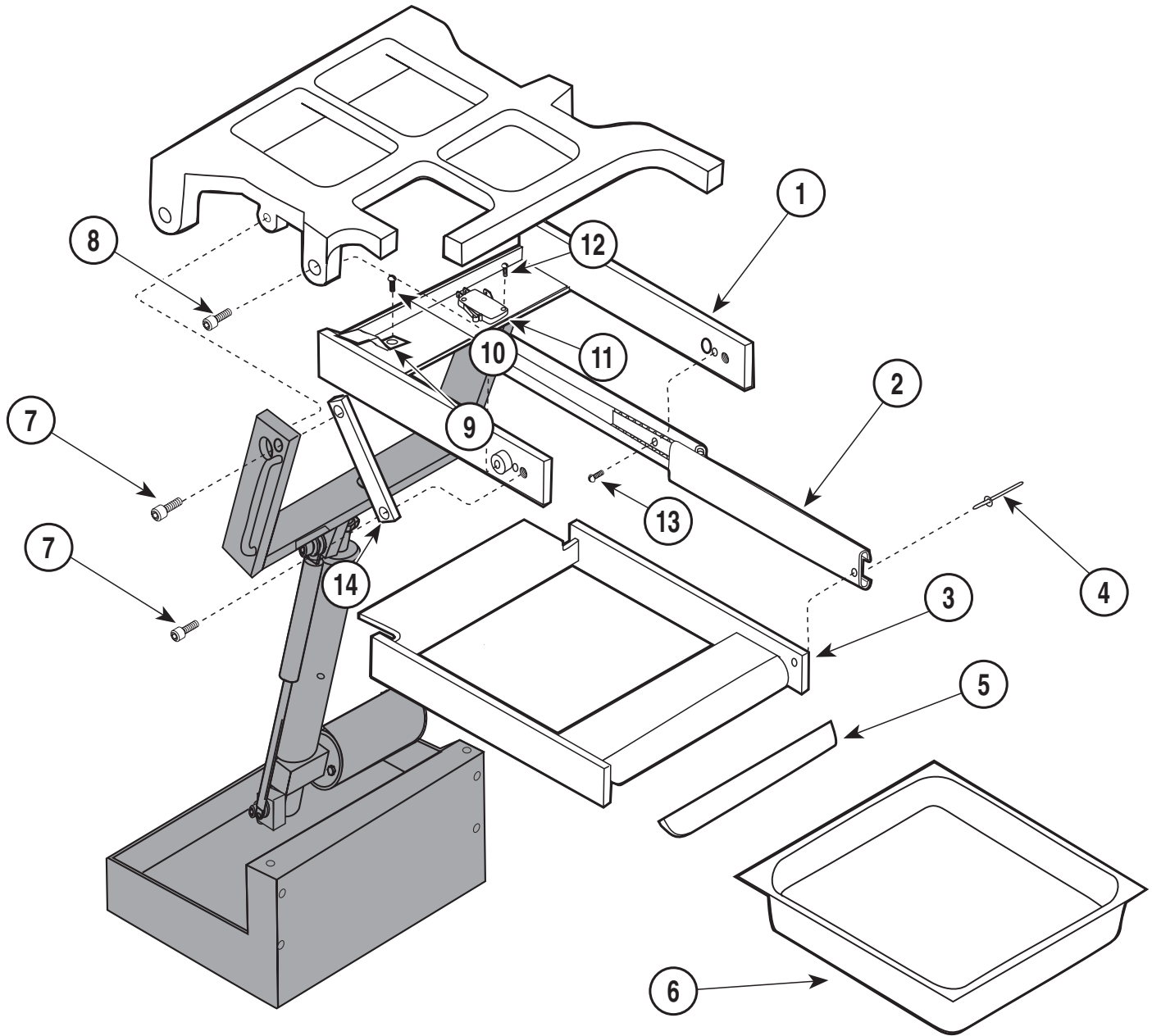

MA306400

**Used on 413 Units with Serial Numbers:  
BK 1000 Thru BK 2512    V 1000 Thru V 1804**

Item	Part No.	Description	Qty.	Item	Part No.	Description	Qty.
	029-0450-00	Pan Assembly .....	1	8	•042-0014-06	Shoulder Bolt .....	2
1	•030-0368-00	Pan Mount Weldment .....	1	9	•050-1514-00	Wire Guard .....	1
2	•016-0269-00	Pan Slides .....	2	10	•040-0010-47	Screw .....	1
3	•030-0716-00	Pan Holder Weldment .....	1	11	•015-0430-00	Switch .....	1
4	•042-0010-03	Pop Rivet .....	4	12	•040-0004-09	Screw .....	2
5	•053-0349-01	Cover Handle .....	1	13	•040-0008-29	Screw .....	6
6	•016-0222-00	Pan 1 .....		14	051-0349-00	Pivot Link .....	2
7	•042-0014-12	Shoulder Bolt .....	4				

Always Specify Model & Serial Number

# Pan Assembly

## SECTION VI PARTS LIST

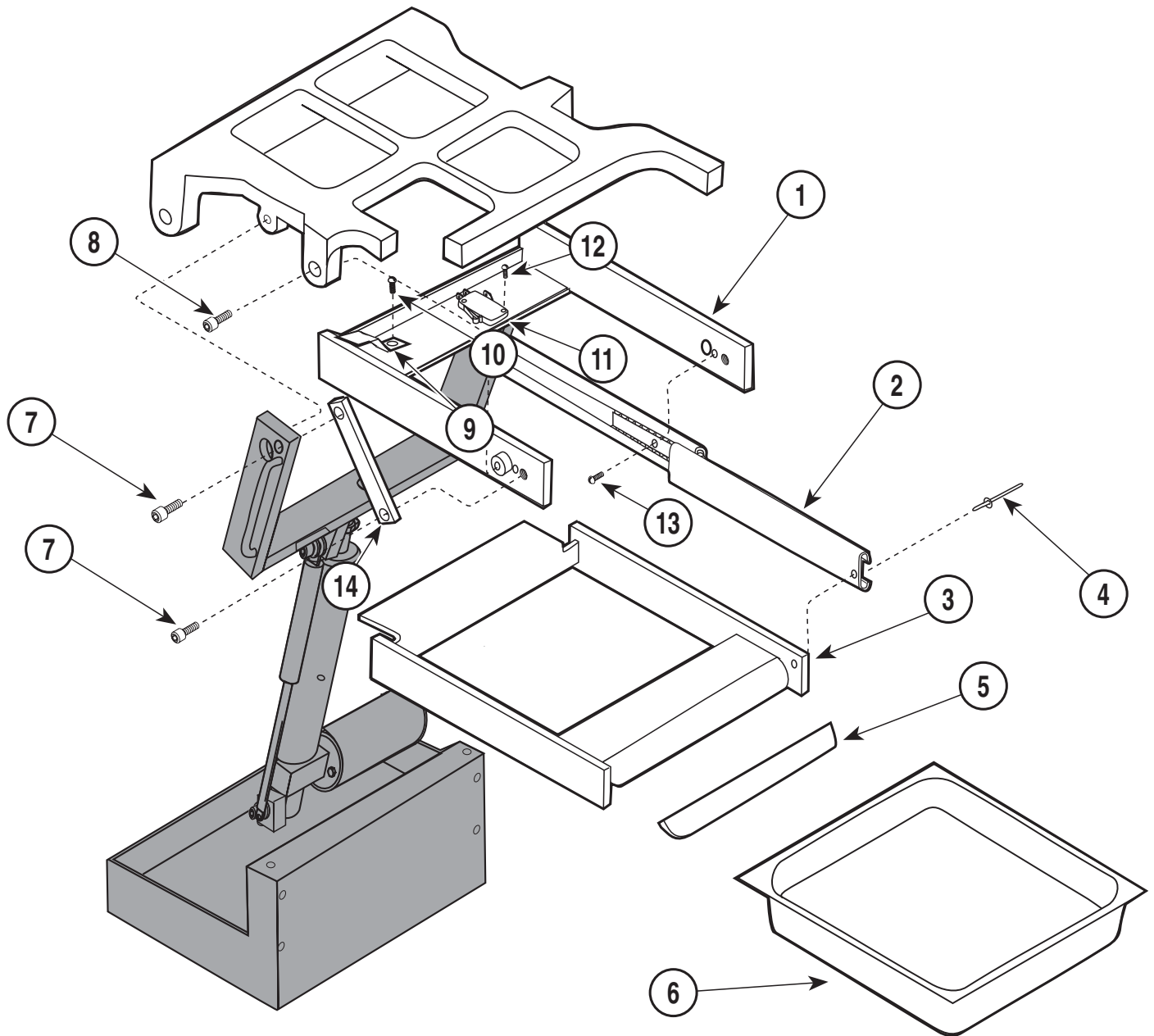

MA306400

**Used on 413 Units with Serial Numbers:  
BK 2513 Thru Present V 1805 Thru Present  
FH 1000 Thru Present**

Item	Part No.	Description	Qty.	Item	Part No.	Description	Qty.
	029-0450-00	Pan Assembly .....	1	8	•042-0014-06	Shoulder Bolt .....	2
1	•030-0368-01	Pan Mount Weldment .....	1	9	•050-1514-00	Wire Guard .....	1
2	•016-0269-00	Pan Slides .....	2	10	•040-0010-47	Screw .....	1
3	•030-0716-01	Pan Holder Weldment .....	1	11	•015-0430-00	Switch .....	1
4	•042-0010-03	Pop Rivet .....	4	12	•040-0004-09	Screw .....	2
5	•053-0349-01	Cover Handle .....	1	13	•040-0008-29	Screw .....	6
6	•016-0222-00	Pan 1 .....	1	14	051-0349-00	Pivot Link .....	2
7	•042-0014-12	Shoulder Bolt .....	4				

Always Specify Model & Serial Number



# Footrest Assembly

## SECTION VI PARTS LIST

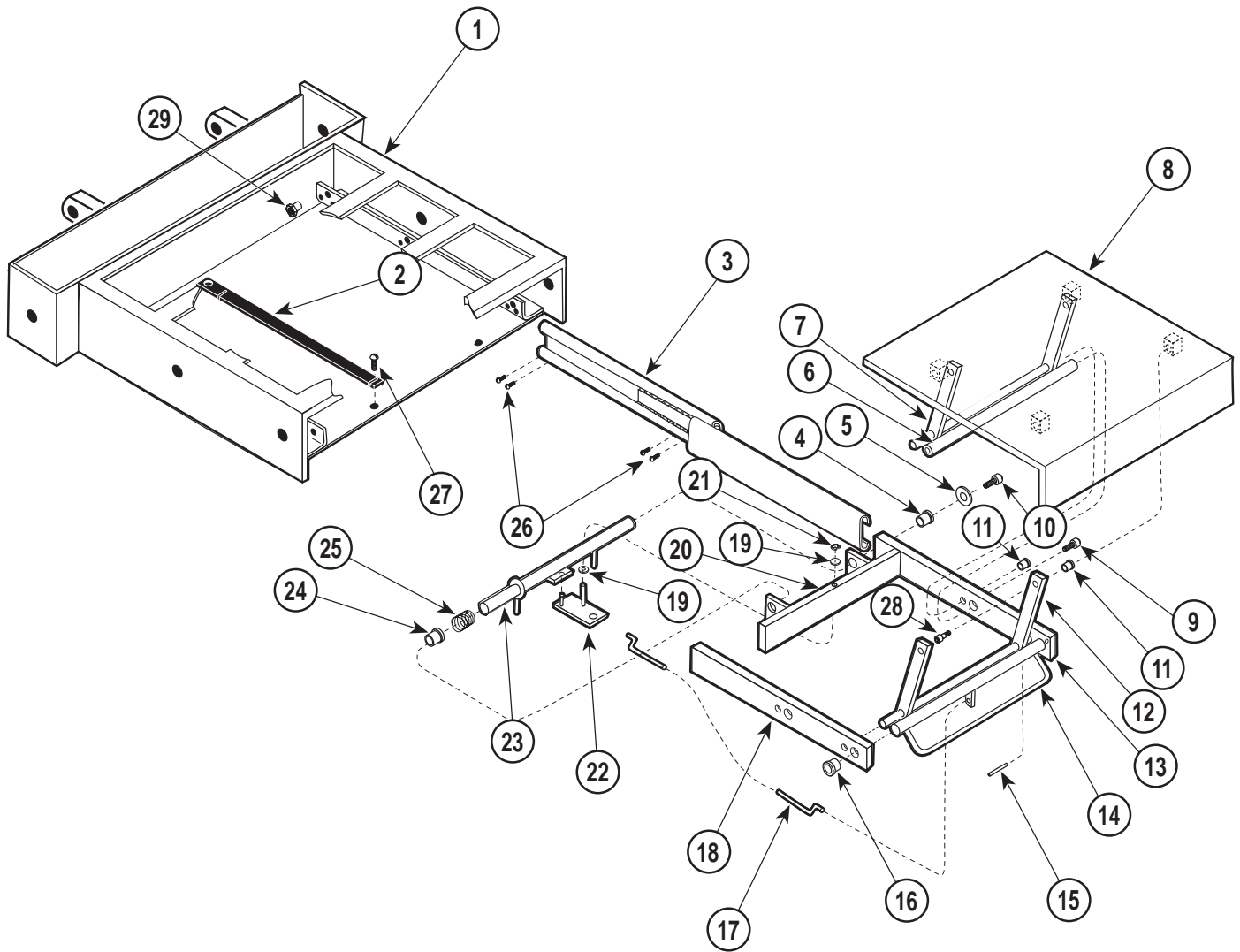

MA306700

**Used on 413 Units with Serial Numbers:  
BK 1000 Thru BK 1271      V 1000 Thru V 1575**

Item	Part No.	Description	Qty.	Item	Part No.	Description	Qty.
1		Seat Weldment (Refer to "Main Frame Section" Elsewhere) .....	1	15	042-0009-05	Groove Pin .....	2
2	030-1132-00	Stop Bar .....	2	16	053-0114-00	Nylon Bearing .....	2
3	016-0215-01	Pan Slide .....	2	17	057-0214-00	Release Wire .....	1
4	053-0226-03	Nylon Bearing .....	1	18	051-0466-00	R.H. Foot Frame .....	1
5	045-0001-55	Washer .....	1	19	045-0007-03	Bearing Washer .....	2
6	057-0215-00	Tie Rod .....	1	20	030-0501-00	Brace .....	1
7	030-0499-00	Rear Torsion Link .....	1	21	042-0007-04	E-Ring .....	1
8	030-0504-00	Foot Section .....	1	22	030-0502-00	Pivot Bar .....	1
9	040-0010-71	Screw .....	6	23	030-0500-00	Transfer Rod .....	1
10	040-0250-39	Screw .....	1	24	053-0114-03	Nylon Bearing .....	1
11	053-0114-02	Nylon Bearing .....	6	25	025-0039-00	Compression Spring .....	1
12	030-0498-00	Front Torsion Link .....	1	26	040-0008-29	Screw .....	16
13	051-0466-01	L.H. Foot Frame .....	1	27	040-0010-50	Screw .....	4
14	030-0503-00	Bail Release .....	1	28	042-0014-22	Shoulder Bolt .....	4
				29	042-0045-02	Nutsert .....	8

**Always Specify Model & Serial Number**

# Footrest Assembly

## SECTION VI PARTS LIST

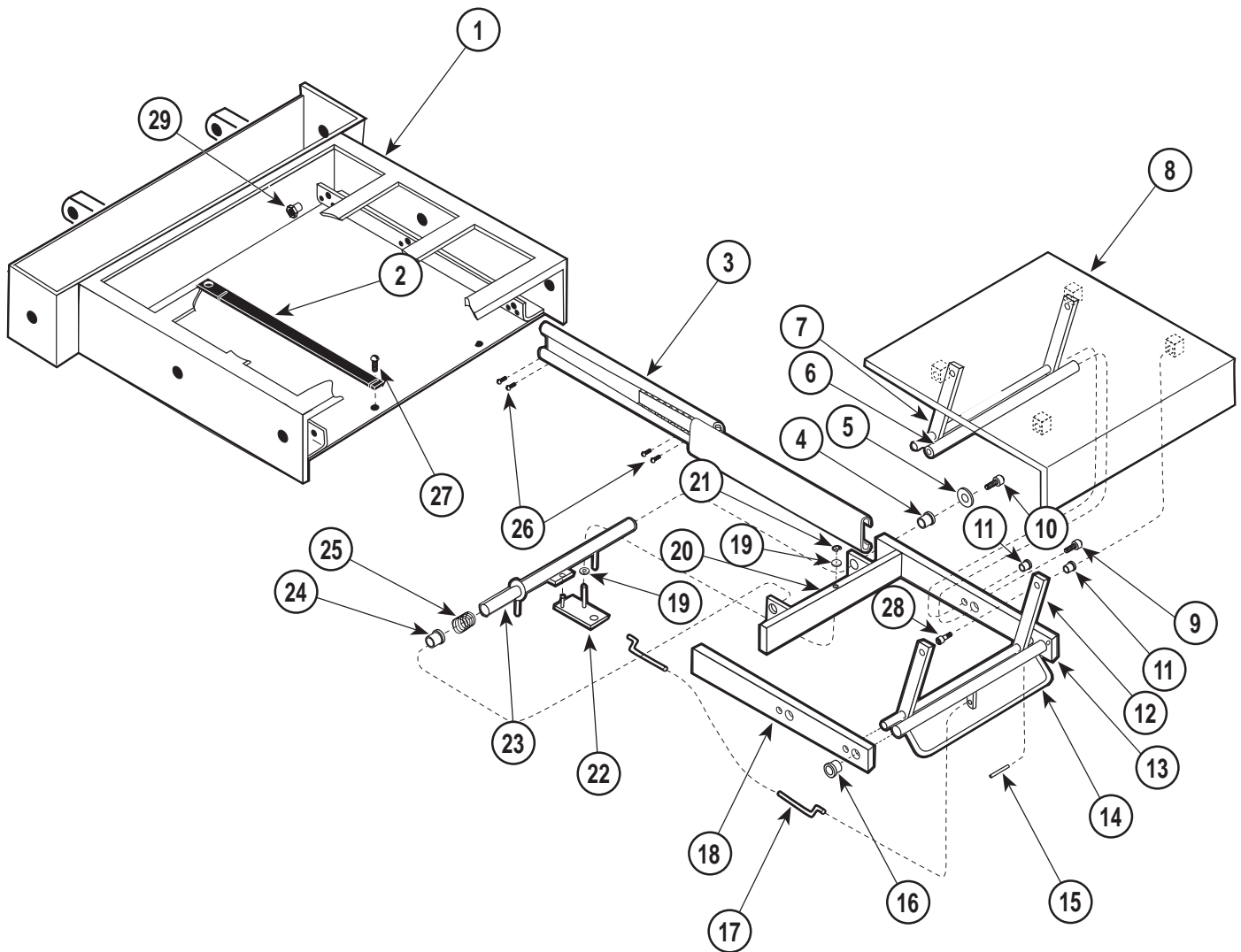

MA306700

**Used on 413 Units with Serial Numbers:  
BK 1272 Thru Present      V 1576 Thru Present  
FH 1000 Thru Present**

Item	Part No.	Description	Qty.	Item	Part No.	Description	Qty.
1		Seat Weldment (Refer to "Main Frame Section" Elsewhere) .....	1	15	042-0009-05	Groove Pin .....	2
2	030-1132-00	Stop Bar .....	2	16	053-0114-00	Nylon Bearing .....	2
3	016-0215-01	Pan Slide .....	2	17	057-0214-00	Release Wire .....	1
4	053-0226-03	Nylon Bearing .....	1	18	051-0466-00	R.H. Foot Frame .....	1
5	045-0001-55	Washer .....	1	19	045-0007-03	Bearing Washer .....	2
6	057-0215-00	Tie Rod .....	1	20	030-0501-00	Brace .....	1
7	030-0499-00	Rear Torsion Link .....	1	21	042-0007-04	E-Ring .....	1
8	030-0504-00	Foot Section .....	1	22	030-0502-00	Pivot Bar .....	1
9	040-0010-71	Screw .....	6	23	030-0500-00	Transfer Rod .....	1
10	040-0250-39	Screw .....	1	24	053-0114-03	Nylon Bearing .....	1
11	053-0114-02	Nylon Bearing .....	6	25	025-0039-00	Compression Spring .....	1
12	030-0498-00	Front Torsion Link .....	1	26	040-0008-29	Screw .....	16
13	051-0466-01	L.H. Foot Frame .....	1	27	040-0010-04	Screw .....	4
14	030-0503-00	Bail Release .....	1	28	042-0014-22	Shoulder Bolt .....	4
				29	042-0045-02	Nutsert .....	8

**Always Specify Model & Serial Number**

# Seat Components

## SECTION VI PARTS LIST

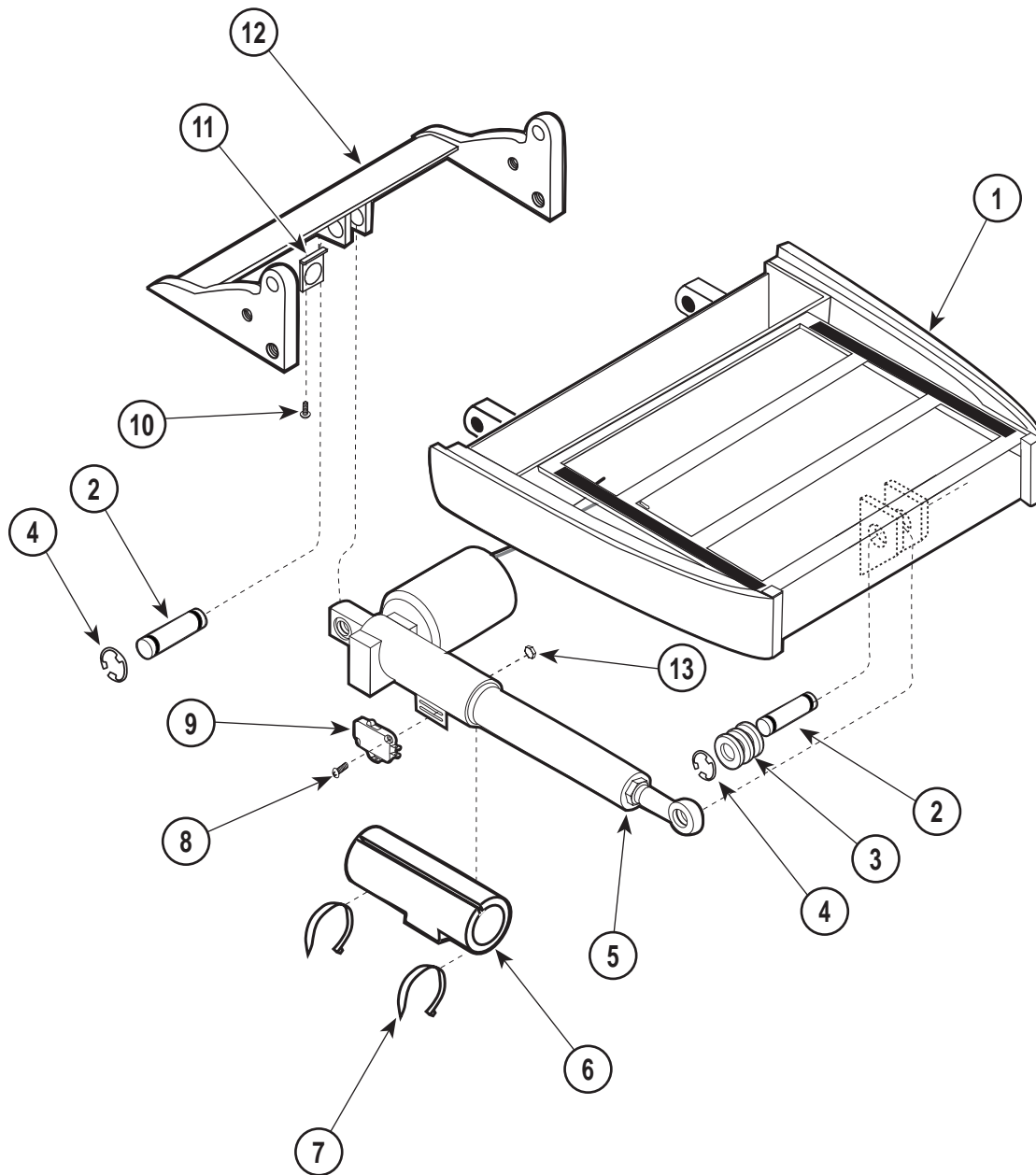

MA306800

### Used on Units with Serial Numbers BK1000 thru BK3576, V1000 thru V1991 and FH1000 thru FH1011

Item	Part No.	Description	Qty.	Item	Part No.	Description	Qty.
1		Seat Weldment (Refer to "Main Frame Section" Elsewhere) .....	Ref.	7	015-0016-00	Cable Tie .....	2
2	040-0048-00	Clevis Pin .....	2	8	040-0004-09	Screw .....	2
3	045-0004-00	Washer .....	6	9	015-0430-00	Switch .....	1
4	042-0007-02	E-Ring .....	4	10	040-0010-47	Screw .....	2
5		Seat Actuator ( Refer to " Seat Actuator" Elsewhere) .....	Ref.	11	050-1513-00	Connector Mount .....	1
6	•053-0186-00	•Actuator Sleeve .....	1	12		Pivot Frame (Refer to "Likage Assembly" Elsewhere) .....	1
				13	041-0004-01	Nut .....	2

Always Specify Model & Serial Number

# Seat Components

## SECTION VI PARTS LIST

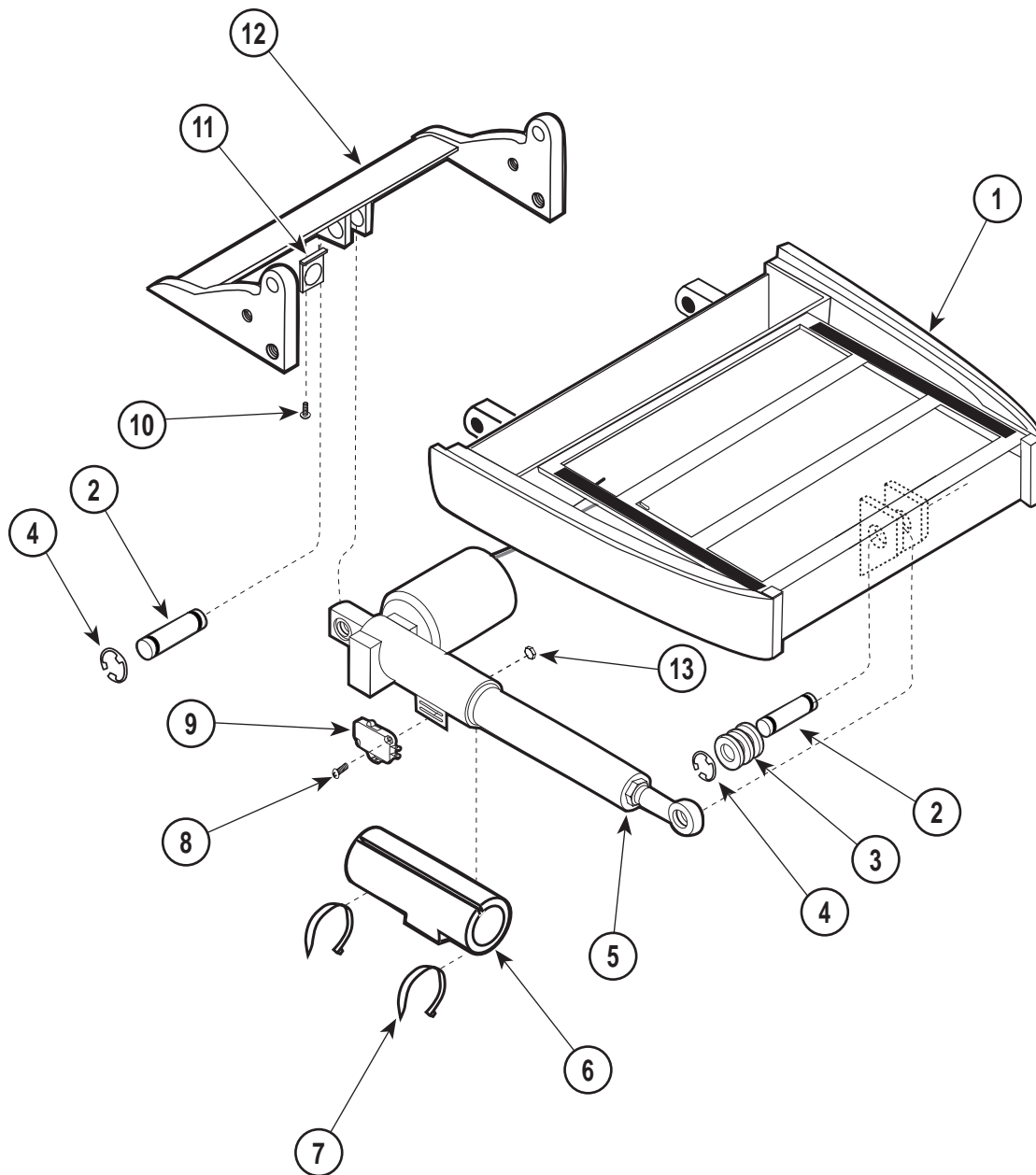

MA306800

### Used on Units with Serial Numbers BK3577, V1992, DT1000 and FH1012 thru Present

Item	Part No.	Description	Qty.	Item	Part No.	Description	Qty.
1		Seat Weldment (Refer to "Main Frame Section" Elsewhere) .....	Ref.	7	015-0016-00	Cable Tie .....	2
2	040-0048-00	Clevis Pin .....	2	8	040-0004-09	Screw .....	2
3	045-0004-00	Washer .....	6	9	015-0430-00	Switch .....	1
4	042-0007-02	E-Ring .....	4	10	040-0010-47	Screw .....	2
5		Seat Actuator ( Refer to " Seat Actuator" Elsewhere) .....	Ref.	11	050-1513-00	Connector Mount .....	1
6	•053-0186-00	•Actuator Sleeve .....	1	12		Pivot Frame (Refer to "Likage Assembly" Elsewhere) .....	1
				13	041-0004-01	Nut .....	2

Always Specify Model & Serial Number

# Seat Actuator

## SECTION VI PARTS LIST

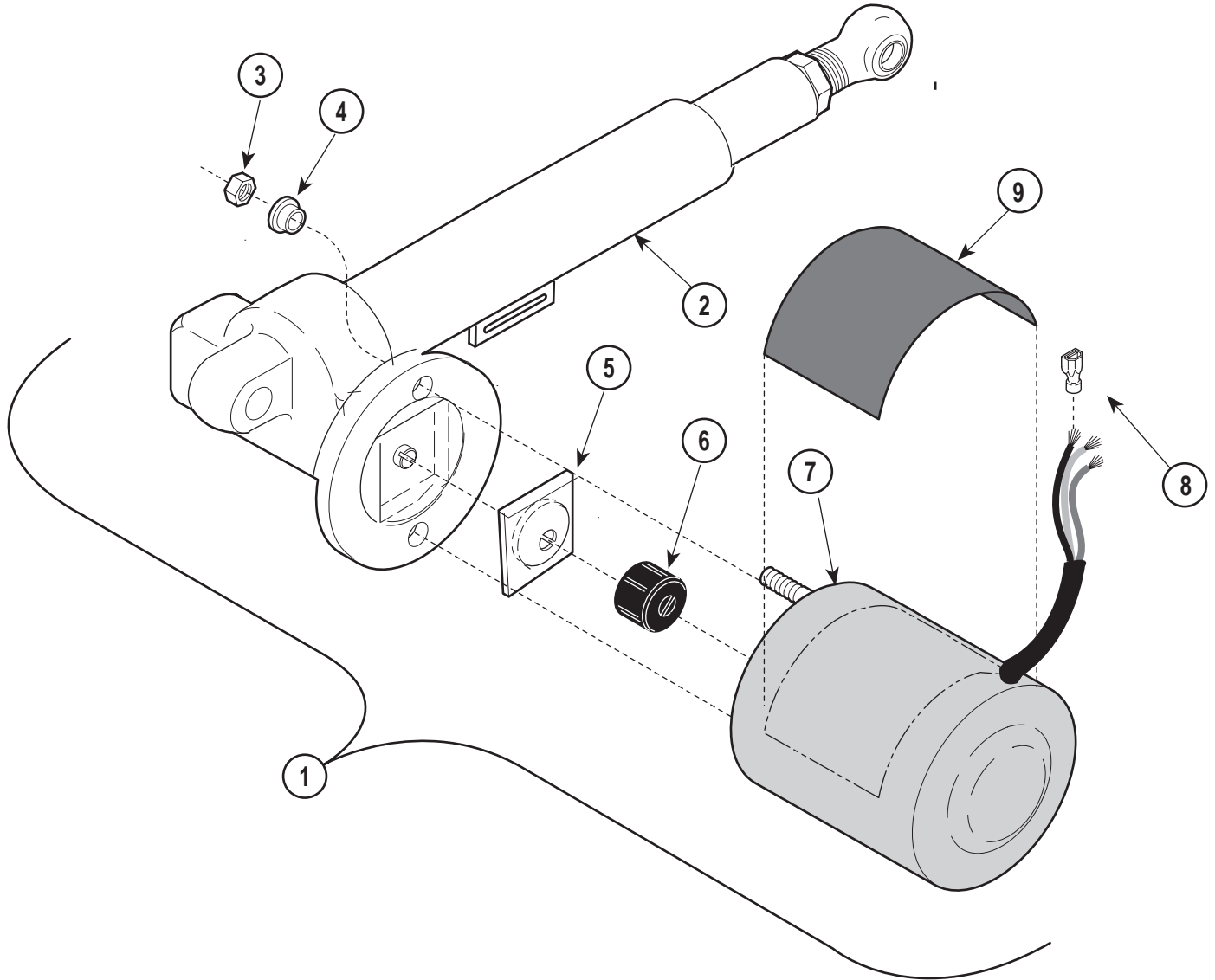

MA306900

**Used on 413 Units with Serial Numbers:  
BK 1000 Thru BK 1271      V 1000 Thru V 1575**

Item	Part No.	Description	Qty.	Item	Part No.	Description	Qty.
1	016-0213-00	Seat Actuator Assembly - Domestic .....	1	5	• 016-0237-00	• Actuator Brake .....	1
		( Includes Items 2 - 8) .....	1	6	• 016-0509-00	• Motor Coupler .....	1
	016-0213-01	Seat Actuator Assembly - Export .....	1	7	• 002-0574-00	• Actuator Motor (Domestic) .....	1
		( Includes Items 2 - 8) .....	1		• 002-0574-01	• Actuator Motor (Export) .....	1
2	• 016-0213-04	• Seat Actuator (Less Motor) .....	1	8	• 015-0018-03	• Terminal .....	3
3	•	• Nut .....	2	9	061-0135-00	Caution Label .....	1
4	• 053-0198-00	• Shoulder Washer .....	2				

**Always Specify Model & Serial Number**

# Seat Actuator

## SECTION VI PARTS LIST

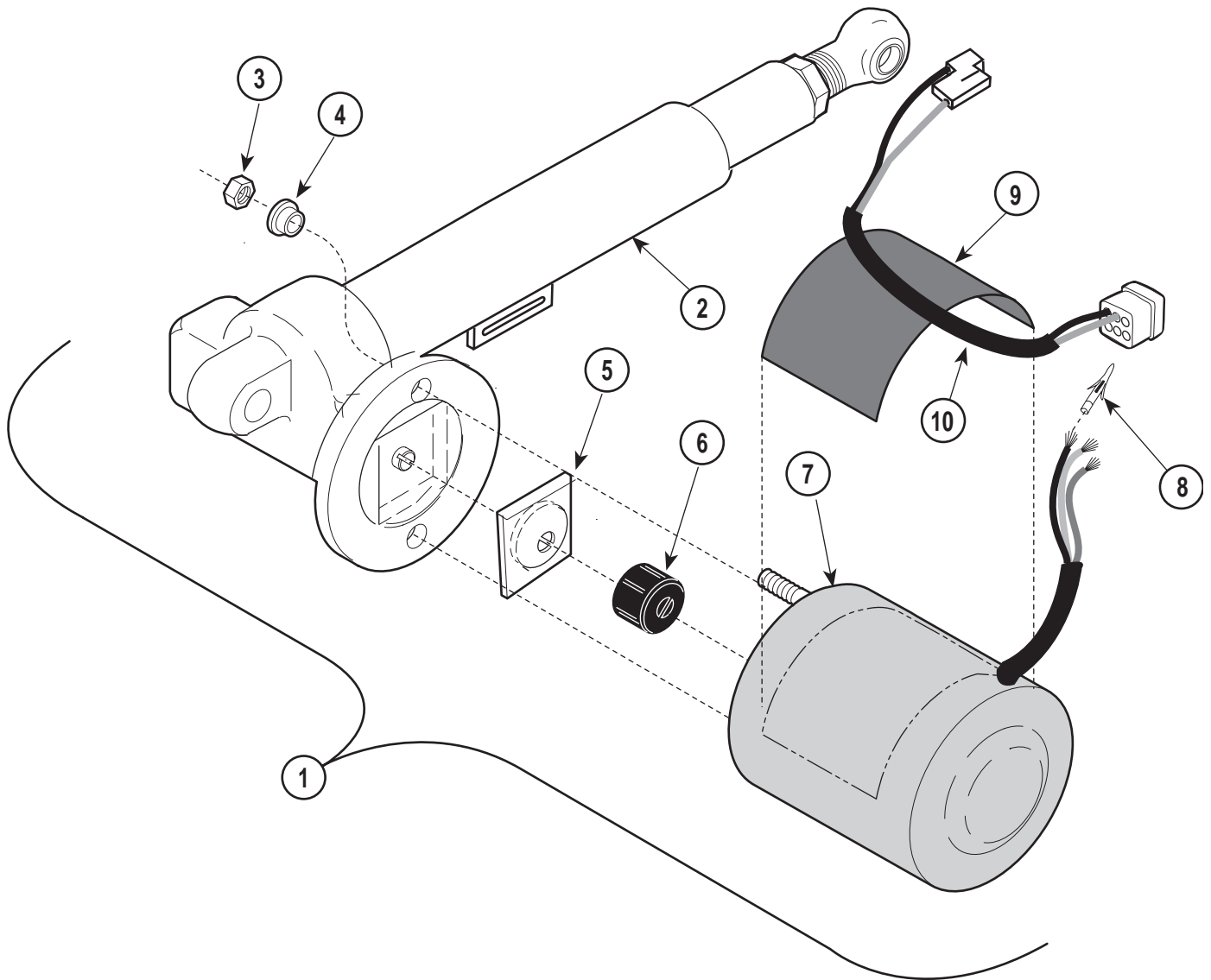

MA306901

### Used on Units with Serial Numbers BK1272 thru BK3547, V1576 thru V1991 and FH1000 thru FH1011

Item	Part No.	Description	Qty.	Item	Part No.	Description	Qty.
1	002-0435-00	Seat Actuator Assembly Kit - Domestic	1	3	•	• Nut	2
	002-0436-00	Seat Actuator Assembly Kit - Export	1	4	• 053-0198-00	• Shoulder Washer	2
	• 016-0213-00	• Seat Actuator-Domestic	1	5	• 016-0237-00	• Actuator Brake	1
	• 016-0213-01	• Seat Actuator-Export	1	6	• 016-0509-00	• Motor Coupler	1
		(Includes Items 2 - 7)	1	7	• 002-0574-00	• Actuator Motor (Domestic)	1
			1		• 002-0574-01	• Actuator Motor (Export)	1
2	• 016-0213-04	• Seat Actuator (Less Motor)	1	8	• 015-0395-04	• Terminal	3
			1	9	061-0135-00	Caution Label	1
			1	10	015-0562-00	Seat Limit Switch Harness	1

Always Specify Model & Serial Number

# Seat Actuator

## SECTION VI PARTS LIST

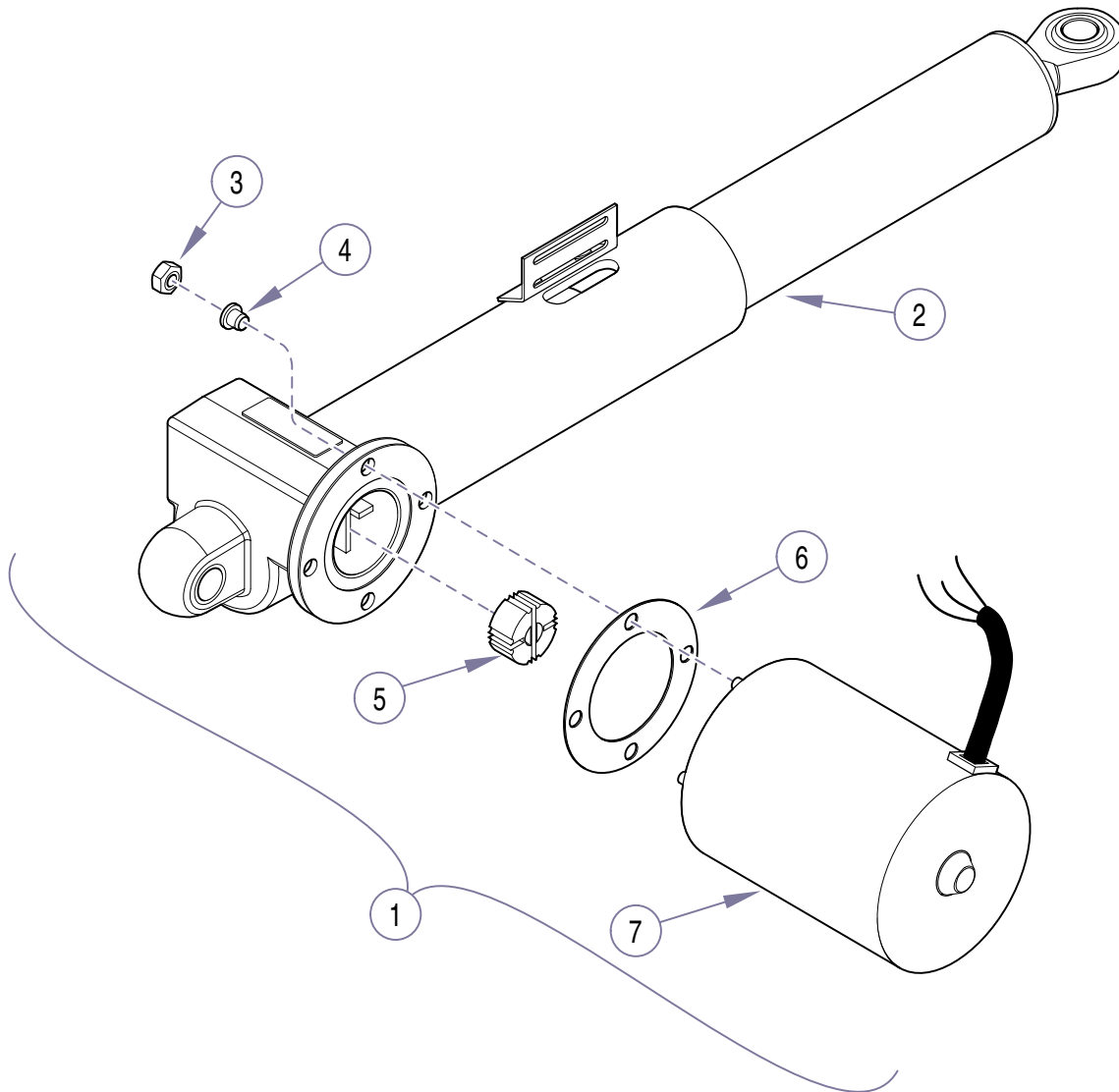

MA604000i

### Used on Units with Serial Numbers BK3577, V1992, DT1000 and FH1012 thru Present

Item	Part No.	Description	Qty.	Item	Part No.	Description	Qty.
1	002-0435-00	Seat Actuator Assembly Kit - Domestic	1	3	• 041-0010-10	• Nut	3
		(Includes Items 2 - 10)	1	4	• 053-0198-00	• Shoulder Washer	3
	002-0436-00	Seat Actuator Assembly Kit - Export	1	5	• 016-0662-00	• Motor Coupler	1
		(Includes Items 2 - 10)	1	6	• 053-0834-00	• Isolation Washer	1
2	•	• Base Actuator-(Less Motor)(Not Available)	Ref.	7	• 015-1085-00	• Actuator Motor (Domestic)	1
					• 015-1085-01	• Actuator Motor (Export)	1

Always Specify Model & Serial Number

# Footswitch

## SECTION VI PARTS LIST

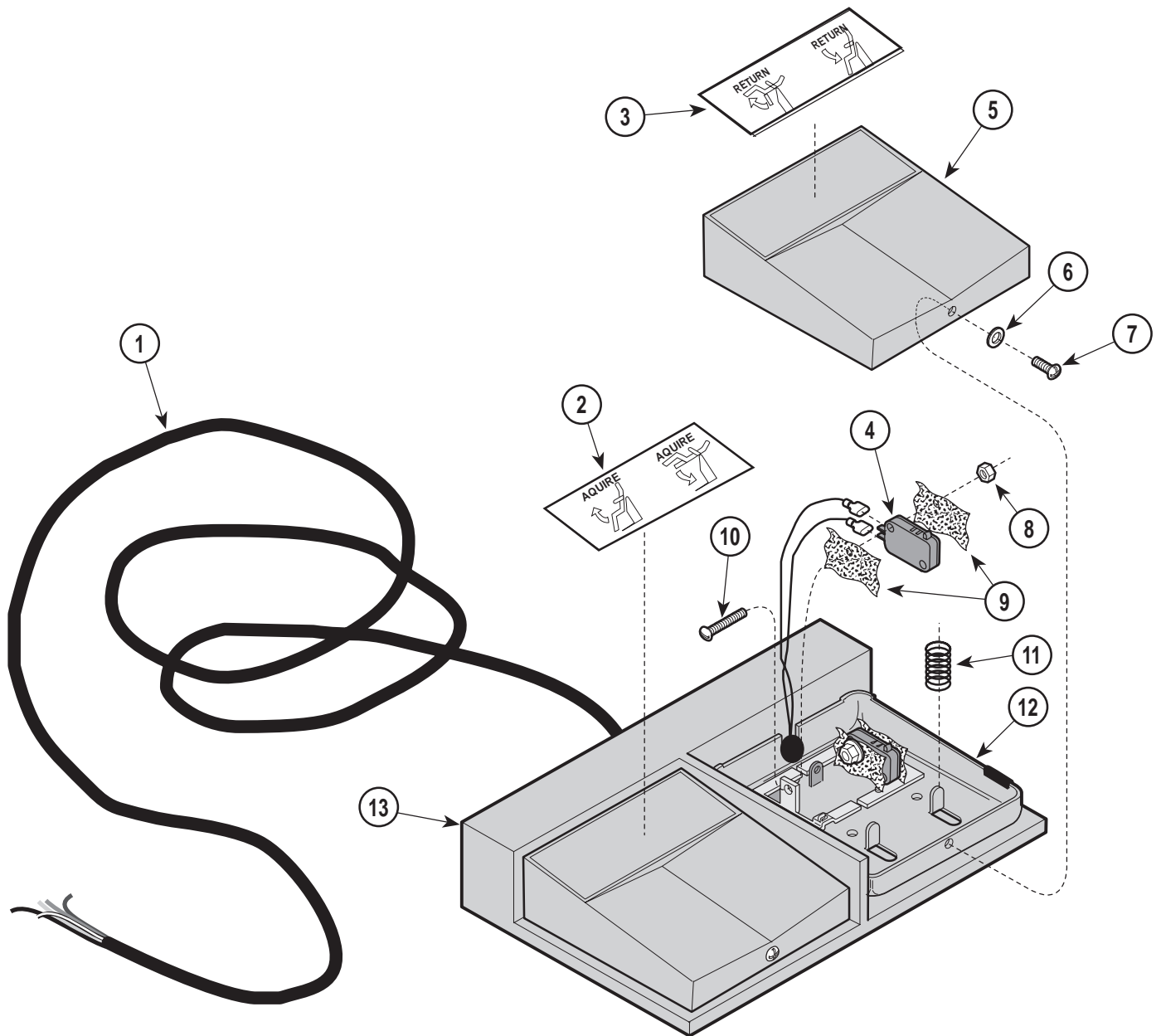

MA201001

Item	Part No.	Description	Qty.	Item	Part No.	Description	Qty.
1	015-0423-00	Footswitch .....	1	7	•	•Screw .....	2
2	•	Cord .....	1	8	•	•Nut .....	4
3	•061-0165-00	•Acquire Label .....	1	9	•	•Insulators .....	4
4	•061-0166-00	•Return Label .....	1	10	•	•Screw .....	4
5	•002-0101-00	•Foot Control Switch .....	4	11	•	•Spring .....	4
6	•	•Footswitch Pedal .....	2	12	•	•Switch Mount .....	2
		•Lockwasher .....	2	13	•	•Base .....	1

Always Specify Model & Serial Number



# Back Panel

## SECTION VI PARTS LIST

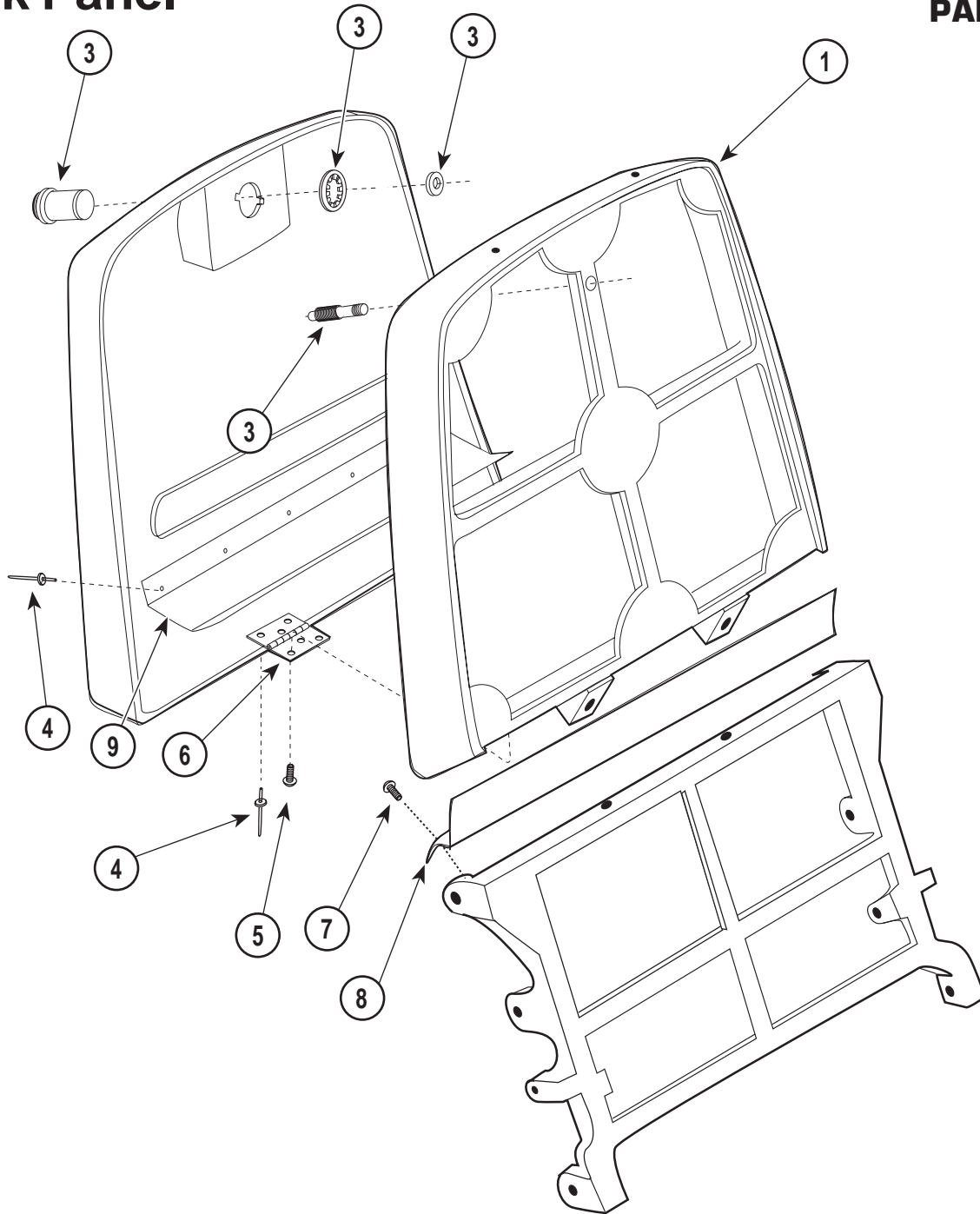

MA307101

### Used on 413 Units with Serial Numbers: BK 1000 Thru BK 1112

Item	Part No.	Description	Qty.	Item	Part No.	Description	Qty.
1		Upper Back (Refer to "Main Frame Section" Elsewhere) .....	Ref.	5	040-0010-04	Screw .....	4
2	053-0182-00	Back Cover .....	1	6	016-0218-00	Hinge .....	2
3	029-0451-00	Push Button Latch Assy. ....	1	7	040-0010-47	Screw .....	5
4	042-0010-02	Pop Rivet .....	9	8	050-1056-00	Cover .....	1
				9	050-1062-00	Paper Roll .....	1

Always Specify Model & Serial Number

# Back Panel

# SECTION VI PARTS LIST

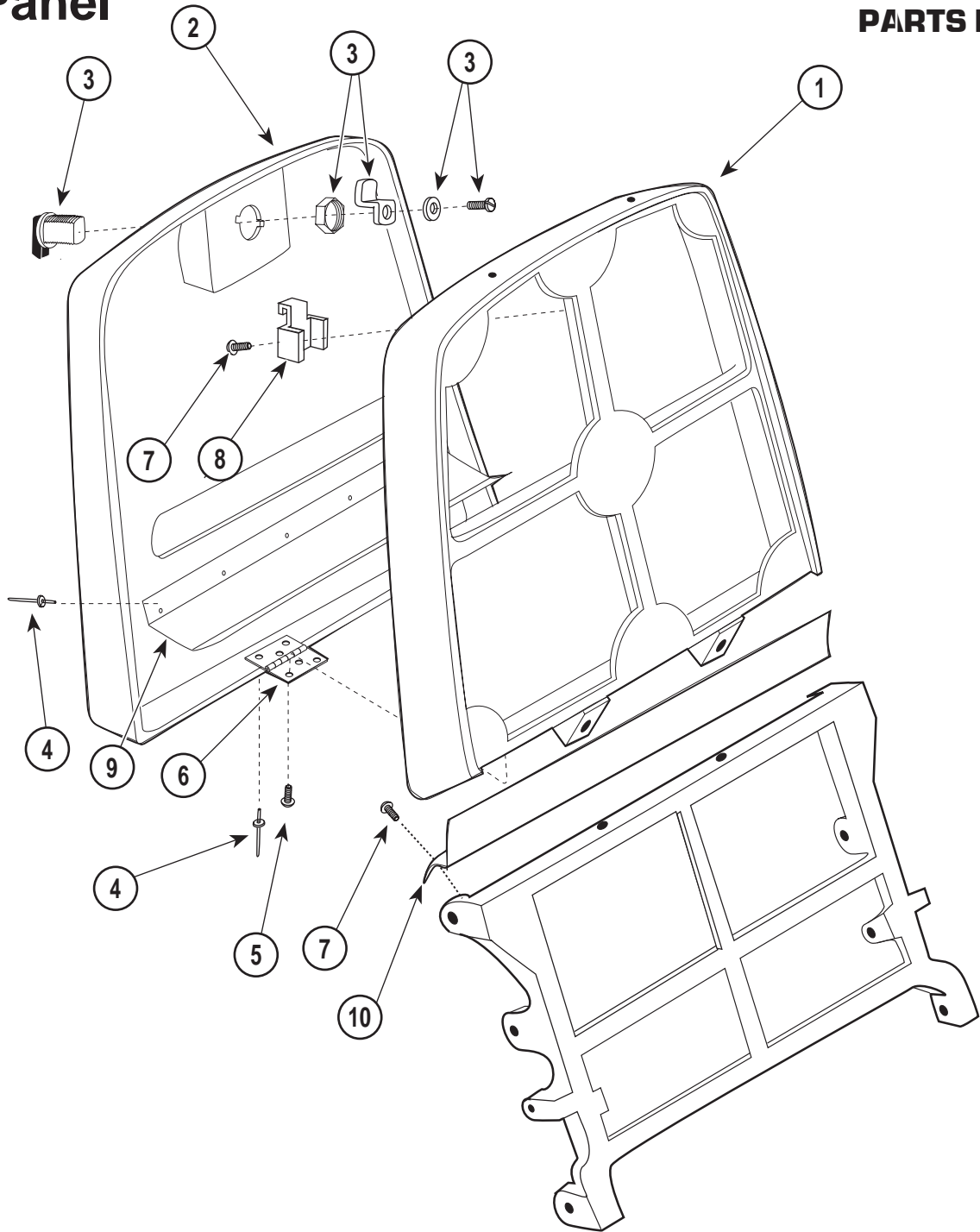

MA307100

**Used on 413 Units with Serial Numbers:  
BK 1113 Thru BK 2512      V 1000 Thru V 1804**

Item	Part No.	Description	Qty.	Item	Part No.	Description	Qty.
1		Upper Back (Refer to "Main Frame Section" Elsewhere) .....	Ref.	6	016-0218-00	Hinge .....	2
2	053-0315-00	Back Cover .....	1	7	040-0010-47	Screw .....	5
3	016-0341-00	1/4 Turn Latch .....	1	8	050-1481-00	Catch .....	1
4	042-0010-02	Pop Rivet .....	9	9	050-1062-00	Paper Roll .....	1
5	040-0010-04	Screw .....	4	10	050-1056-00	Cover .....	1

**Always Specify Model & Serial Number**

# Back Panel

## SECTION VI PARTS LIST

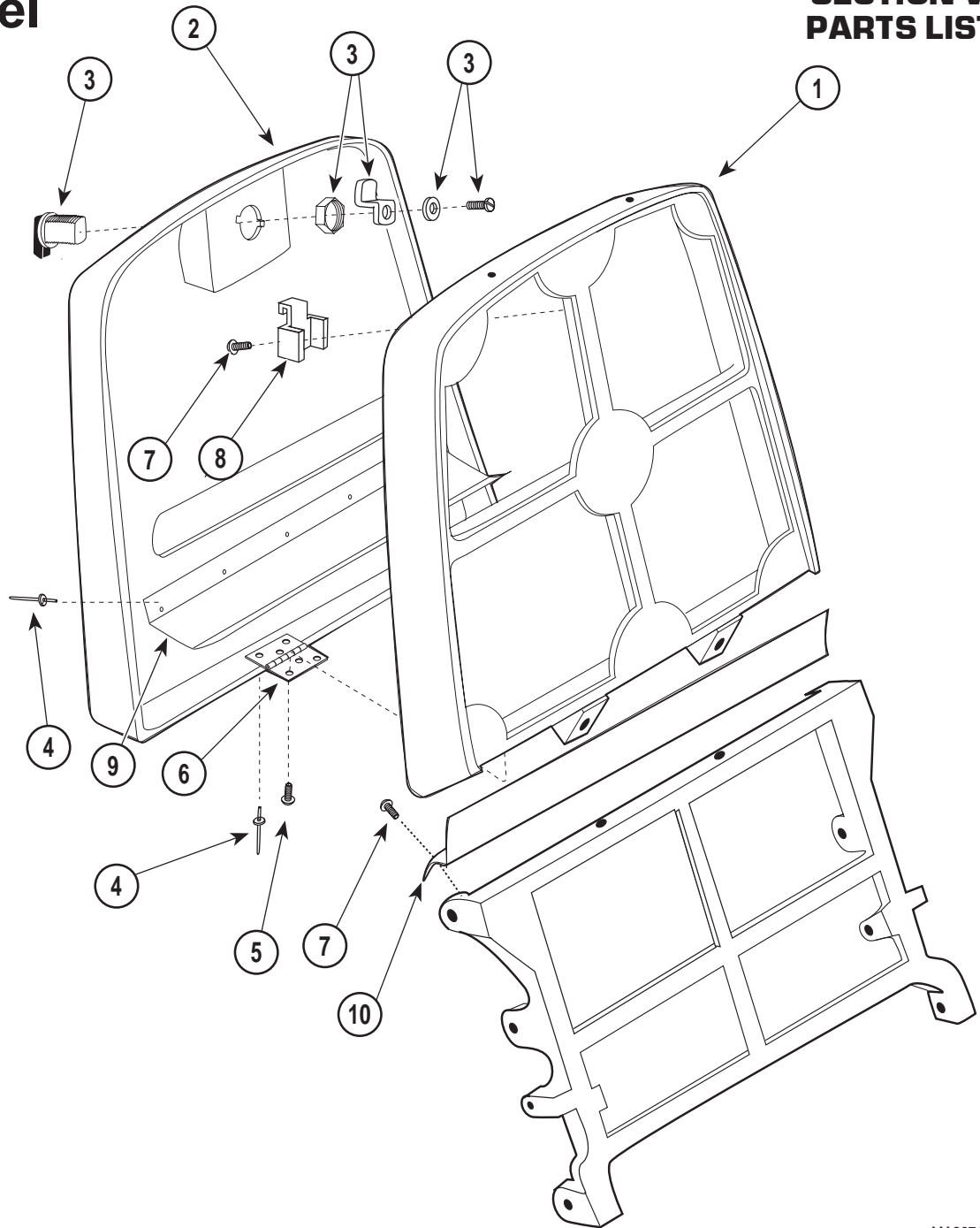

MA307100

**Used on 413 Units with Serial Numbers:  
BK 2513 Thru Present      V 1805 Thru Present  
FH 1000 Thru Present**

Item	Part No.	Description	Qty.	Item	Part No.	Description	Qty.
1		Upper Back (Refer to "Main Frame Section" Elsewhere) .....	Ref.	6	016-0218-00	Hinge .....	2
2	053-0315-00	Back Cover .....	1	7	040-0010-47	Screw .....	5
3	016-0341-00	1/4 Turn Latch .....	1	8	050-1481-00	Catch .....	1
4	042-0010-02	Pop Rivet .....	9	9	050-1062-00	Paper Roll .....	1
5	040-0010-04	Screw .....	4	10	050-1056-01	Cover .....	1

**Always Specify Model & Serial Number**

# Wiring Locations

## SECTION VI PARTS LIST

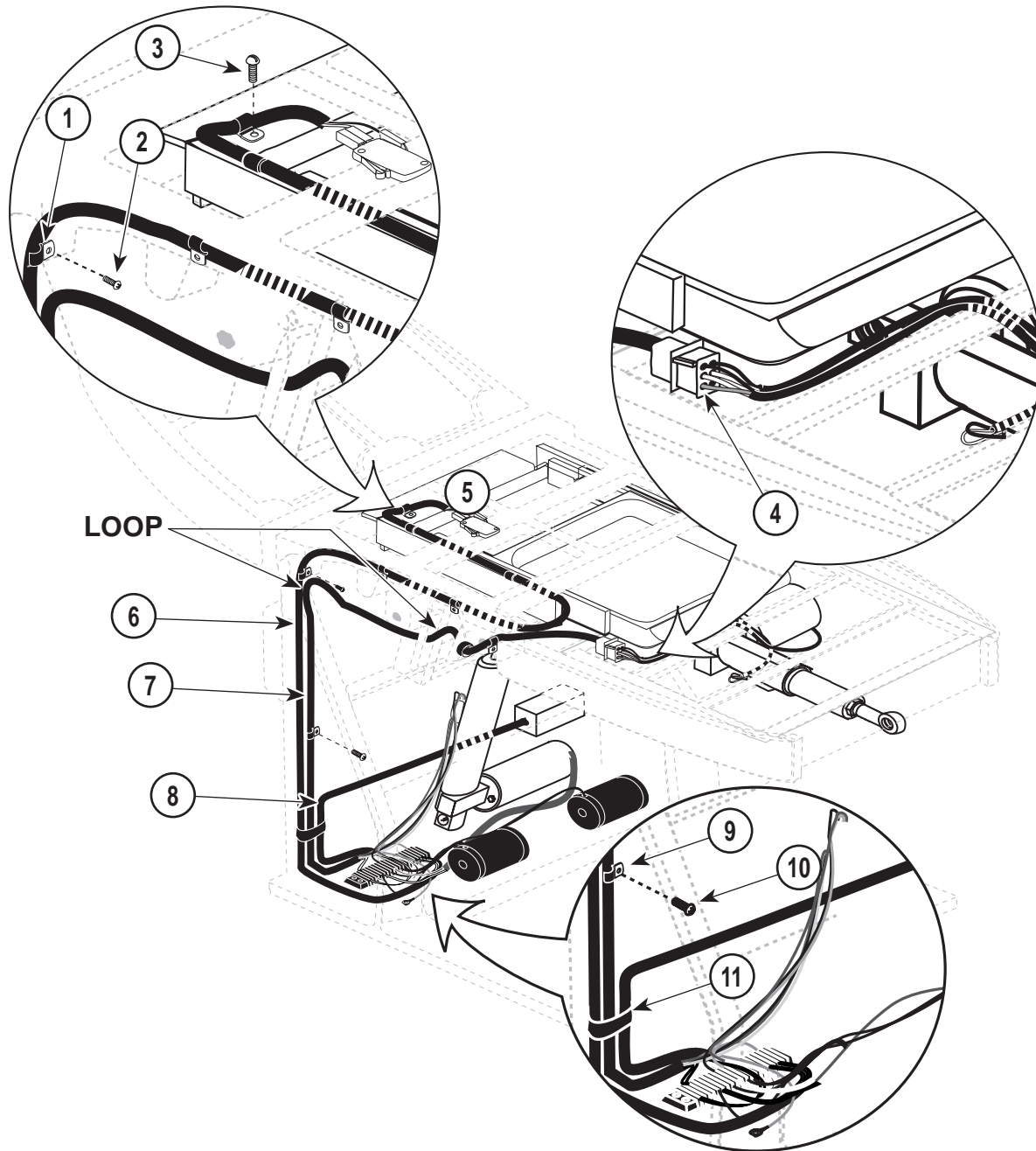

MA307301

Item	Part No.	Description	Qty.	Item	Part No.	Description	Qty.
1	015-0014-02	Cable Clamp 1/4" .....	7	7		Wiring Harness - Seat Actuator (Refer to "Wiring Schematic" Section 5) .....	Ref.
2	040-0010-47	Screw .....	5	8		Wiring Harness - Receptacle (Refer to "Wiring Schematic" Section 5) .....	Ref.
3	040-0008-29	Screw .....	3	9	015-0371-00	Cable Clamp 5/16" .....	2
4	015-0541-00	6 - Circuit Plug .....	1	10	040-0010-47	Screw .....	1
5	053-0068-08	Snap Bushing		11	015-0013-02	Cable Tie .....	5
6		Wiring Harness - Pan Limit Switch (Refer to "Wiring Schematic" Section 5) .....	Ref.				

Always Specify Model & Serial Number

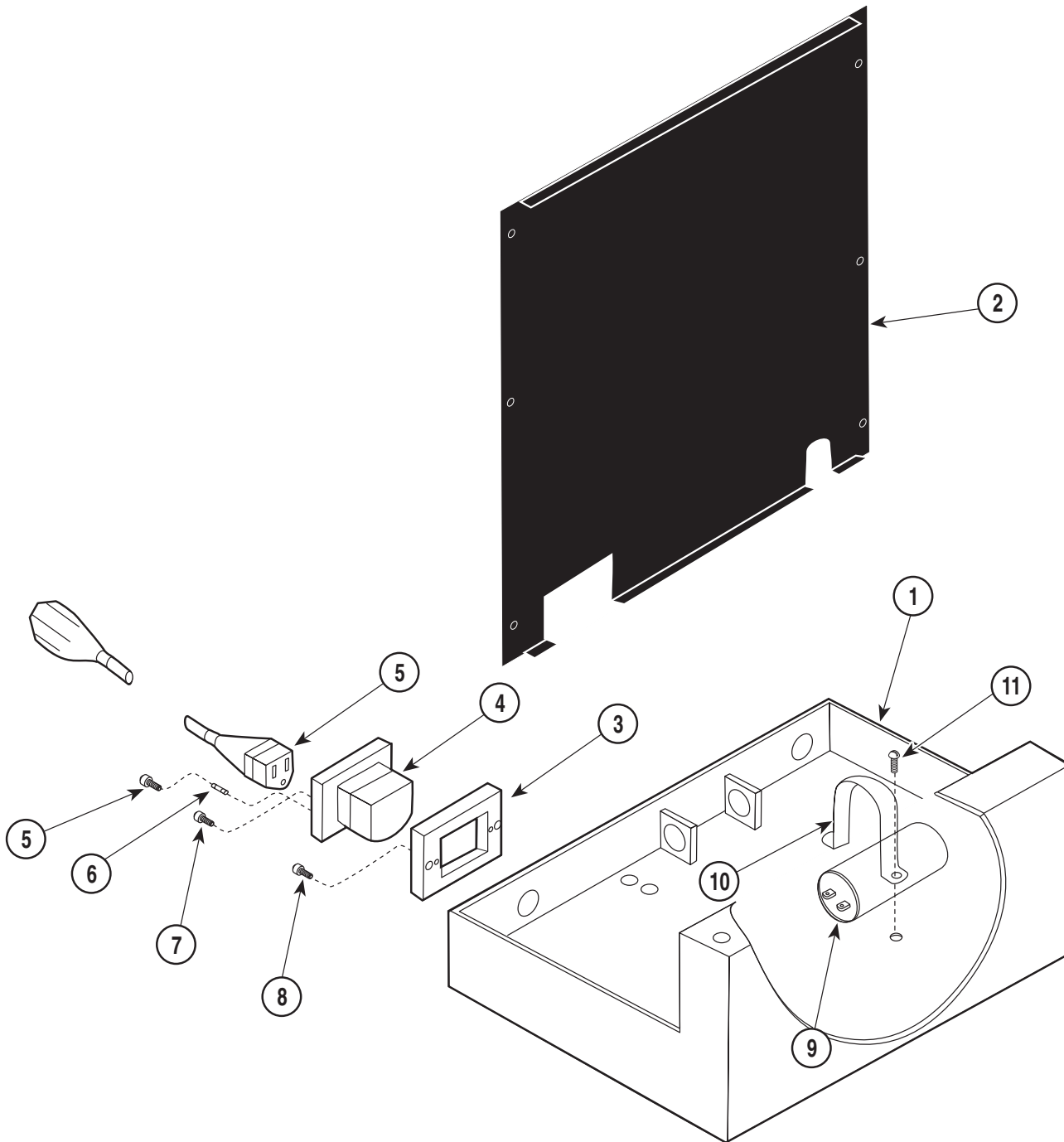

MA307500

**Used on 413 Units with Serial Numbers:  
BK 1000 Thru BK 3219 V 1000 Thru V 1935  
FH 1000 Thru FH 1001**

Item	Part No.	Description	Qty.	Item	Part No.	Description	Qty.
1		Cross Support (Refer to "Cross Support" Elsewhere) .....	Ref.	6	015-0348-01	Fuse .....	2
2	050-1069-01	Back Shroud .....	1	7	040-0004-11	Screw .....	2
3	051-0351-02	Cord Inlet .....	1	8	040-0010-52	Screw .....	2
4	N.L.A.	Appliance Inlet .....	1	9	015-0438-04	Capacitor .....	2
5	015-0363-00	Cord Set .....	1	10	015-0693-00	Capacitor Clamp .....	2
				11	040-0010-47	Screw .....	4

*N.L.A. Denotes "No Longer Available"*  
**Always Specify Model & Serial Number**

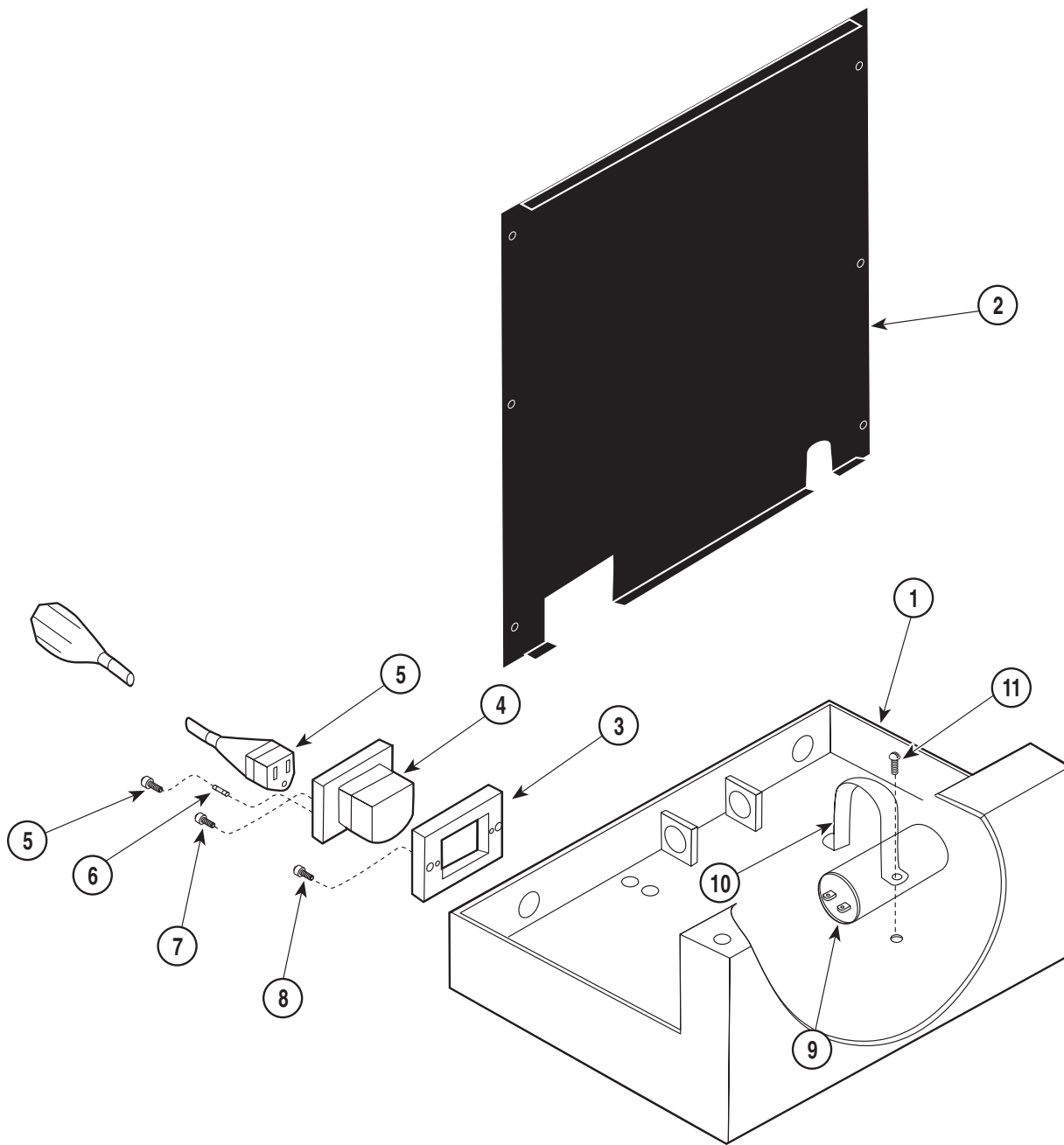

MA307500

**Used on 413 Units with Serial Numbers:**  
**BK 3220 Thru Present      V 1636 Thru Present**  
**FH 1002 Thru Present      DT 1000 Thru Present**

Item	Part No.	Description	Qty.	Item	Part No.	Description	Qty.
1		Cross Support (Refer to "Cross Support" Elsewhere) .....	Ref.	5	015-0363-00	Cord Set	
2	050-3787-00	Back Shroud .....	1	6	015-0348-01	Fuse .....	2
3	051-0351-02	Cord Inlet .....	1	7	040-0004-11	Screw .....	2
4	N.L.A.	A. C. Connector Recepticle (Complete)		8	040-0010-52	Screw .....	2
	• N.L.A.	• Fuse .....	2	9	015-0438-04	Capacitor .....	2
	• N.L.A.	• Inlet Housing .....	1	10	015-0693-00	Capacitor Clamp .....	2
	• N.L.A.	• Fuse Holder .....	2	11	040-0010-47	Screw .....	4

*N.L.A. Denotes "No Longer Available"*  
**Always Specify Model & Serial Number**

## COMMENTS

The Technical Publications Department of Midmark Corporation takes pride in its publications. We are sure that our manuals will fill all of your needs when you are performing scheduled maintenance, servicing, or repairs on a Midmark product.

However, if you find any errors or feel that there should be a change, addition, or deletion to a manual, please let us know!

**Page(s) and Paragraph(s) Needing Changed:**

**Description of Error or Desired Change:**

Please fax or mail a copy of this completed comment sheet to:

Midmark Corporation  
ATTN: Technical Publications Department  
60 Vista Drive  
Versailles, Ohio 45380  
Fax: (937) 526-5542

# FAX ORDERING FORM

(SERVICE PARTS ONLY)

**NOTES:**

- ALL **BLOCKED** AREAS MUST BE COMPLETED.
- USE FOR NON-WARRANTY FAX ORDERS ONLY. WARRANTY ORDERS MUST BE TELEPHONED IN (1-800-MIDMARK).

ATTENTION: SERVICE DEPARTMENT FAX#: 877-249-1793				
ACCT #: _____		P.O. #: _____		DATE: _____
NAME: _____		SHIP TO: _____		
ADDRESS: _____		_____		
CITY, ST.: _____		_____		
CONTACT: _____		_____		
PHONE: _____		_____		
<input type="checkbox"/> NON-EMERGENCY ORDER - TO SHIP WITHIN 72 HOURS IF PART(S) IN STOCK.		METHOD OF SHIPMENT <span style="float: right;"><u>OTHER</u> _____</span>		
<input type="checkbox"/> EMERGENCY ORDER - TO SHIP WITHIN 24 HOURS IF PART(S) IN STOCK (IF ORDER IS RECEIVED BEFORE 1:00 P.M. E.S.T).		UPS <span style="margin-left: 100px;">FED EX</span>		
SEND NOTIFICATION IF PARTS ARE NOT AVAILABLE TO SHIP WITHIN 24 HOURS VIA E-MAIL OR FAX TO: _____		<input type="checkbox"/> NEXT DAY A.M. <input type="checkbox"/> NEXT DAY A.M. <input type="checkbox"/> NEXT DAY P.M. <input type="checkbox"/> NEXT DAY P.M. <input type="checkbox"/> 2ND DAY <input type="checkbox"/> 2ND DAY <input type="checkbox"/> GROUND <input type="checkbox"/> ECONOMY		
QTY.	PART #	DESCRIPTION (SPECIFY COLOR OF ITEM IF APPLICABLE)	COLOR CODE	PRICE/PER
TOTAL COST: \$				





Midmark Corporation  
60 Vista Drive  
P.O. Box 286  
Versailles, Ohio 45380-0286  
937-526-3662  
Fax 937-526-5542  
midmark.com



Because we care.

Subject to change without notice.  
Refer to [www.Documark.com](http://www.Documark.com) for latest revision.