

112/113⁻⁰⁰¹

Ritter®

by MIDMARK

Special
Procedure
Table

Serial Number Prefix:
AF (112) & AG (113)

Service and Parts Manual

**NO LONGER IN
PRODUCTION**
Some service parts may not
be available for this product!

112
113

FOR USE BY MIDMARK
TRAINED TECHNICIANS ONLY

TABLE OF CONTENTS

| Subject | Page |
|---|------------|
| Important Instructions | 2 |
| Introduction | . |
| Parts Replacement | 3 |
| Headlock Adjustment | . |
| Removal & Replacement of Upholstered Sections | 4 |
| Removal & Replacement of Table Panels | 6 |
| Removal & Replacement of Motor Cover, Control Box Cover & Shrouds. | 7 |
| Removal & Replacement of Rubberized Tread | 9 |
| Power System Operation & Maintenance | 9 |
| Hydraulic System | |
| Adding Oil | 9 |
| Oil Leaks | 10 |
| Cylinder Leaks | 10 |
| Hose Line Leaks | 10 |
| Hose Identification | 11, 12, 13 |
| Removal & Replacement of Hydraulic Cylinders | |
| Back Cylinder | 14 |
| Tilt Cylinder | 15 |
| Foot Cylinder | 16 |
| Base Cylinder | 17 |
| Lift and Stabilizing Chain Adjustment | 18 |
| Removal & Replacement of Power System Parts | |
| Power Cord | 19 |
| Motor Capacitors | 19 |
| Anticavitation Solenoid Valve | 19 |
| Time Delay Relay | 20 |
| Motor/Pump | 20 |
| Auto Return Operation . Maintenance | |
| Removal and Replacement of Auto Return and Stop Switches | 21 |
| Removal and Replacement of Base Limit Switch. | 21 |
| Removal and Replacement of Auto Return Relay | 22 |
| Footswitch | |
| Removal and Replacement of Footswitch | 22 |
| Removal and Replacement of Foot Control Module | 22 |
| Removal and Replacement of Foot Control Switches | 23 |
| Removal and Replacement of Footswitch Cord | 23 |
| Adjustment of Flow Controls | 23 |
| Adjustment of Needle Valve Model 112 and 113 | 24 |
| Special Tools | 24 |
| Troubleshooting Guide | 25 |
| Hydraulic Flow Diagram. .. | 29 |
| 111, 112, 114 Wiring Diagram | 31 |
| 113 Wiring Diagram | 32 |

IMPORTANT INSTRUCTIONS

Safety First

Throughout this manual are "Notes", "CAUTIONS", and "**DANGER**" warnings that call attention to particular procedures. The items are used as follows:

Note: A note is used to amplify an operating procedure, practice or condition.

CAUTION: A CAUTION IS USED FOR AN OPERATING PROCEDURE, PRACTICE, OR CONDITION WHICH, IF NOT CORRECTLY FOLLOWED, COULD RESULT IN EQUIPMENT DAMAGE.

DANGER: A DANGER IS USED FOR AN OPERATING PROCEDURE, PRACTICE, OR CONDITION WHICH, IF NOT CORRECTLY FOLLOWED, COULD RESULT IN PERSONAL INJURY.

For your personal safety all DANGER warnings are repeated here. Become thoroughly familiar with them and observe them at all times.

1. **KEEP HANDS, FINGERS AND ALL OTHER PARTS OF THE BODY AWAY FROM AND FREE OF MOVING PARTS. FAILURE TO FOLLOW THIS COULD RESULT IN PERSONAL INJURY.**
2. **ALWAYS DISCONNECT THE TABLE POWER CORD FROM THE WALL RECEPTACLE BEFORE ATTEMPTING ANY SERVICE OR MAINTENANCE OF THE EQUIPMENT. FAILURE TO DISCONNECT POWER CORD COULD RESULT IN PERSONAL INJURY OR EQUIPMENT DAMAGE.**
3. **DO NOT ATTEMPT TO REMOVE THE LEVER MECHANISM FROM THE UNDERSIDE OF THE FOOTREST. REMOVING THE LEVER MECHANISM COULD RESULT IN PERSONAL INJURY.**
4. **FAILURE TO LOCK THE FOOTREST SECTION INTO POSITION COULD RESULT IN PERSONAL INJURY OR EQUIPMENT DAMAGE.**
5. **DISCONNECT POWER CORD FROM WALL RECEPTACLE. FAILURE TO DISCONNECT POWER CORD COULD RESULT IN PERSONAL INJURY.**
6. **WHEN REPLACING THE WIRE RACEWAY, BE SURE ALL WIRES ARE CONFINED WITHIN RACEWAY. FAILURE TO CONTAIN WIRES COULD RESULT IN PERSONAL INJURY OR EQUIPMENT DAMAGE.**
7. **WHEN REPLACING THE MOTOR COVER, BE SURE ALL WIRES AND HOSES ARE INSIDE OF COVER. FAILURE TO DO THIS COULD RESULT IN ELECTRICAL SHOCK OR EQUIPMENT DAMAGE.**
6. **DISCONNECT POWER CORD FROM WALL RECEPTACLE BEFORE REMOVING OR REPLACING MOTOR COVER AND SHROUDS. FAILURE TO DISCONNECT POWER CORD COULD RESULT IN PERSONAL INJURY.**
9. **WHEN CHANGING A CYLINDER, NOTE HOW THE WIRES, HOSES, HOSE FITTINGS, AND NYLON TIES ARE POSITIONED SO THAT THEY MAY BE REPLACED EXACTLY THE SAME WAY OR DAMAGE TO THE WIRES AND HOSES MAY OCCUR RESULTING IN ELECTRICAL SHOCK OR EQUIPMENT DAMAGE.**
10. **BACK SECTION MUST BE SUPPORTED UNTIL NEW CYLINDER IS INSTALLED. FAILURE TO SUPPORT BACK SECTION COULD RESULT IN PERSONAL INJURY OR EQUIPMENT DAMAGE.**
11. **BE SURE POWER CORD IS DISCONNECTED FROM WALL RECEPTACLE. FAILURE TO DISCONNECT POWER CORD COULD RESULT IN ELECTRICAL SHOCK.**
12. **TABLE TOP MUST BE SUPPORTED UNTIL NEW CYLINDER IS INSTALLED. FAILURE TO SUPPORT TABLE TOP COULD RESULT IN PERSONAL INJURY OR EQUIPMENT DAMAGE.**
13. **THREE PERSONS ARE REQUIRED TO CHANGE A BASE CYLINDER. TWO PERSONS MUST SUPPORT THE TABLE TOP AS THE THIRD PERSON REMOVES THE CYLINDER. FAILURE TO USE THREE PERSONS COULD RESULT IN PERSONAL INJURY OR EQUIPMENT DAMAGE.**
14. **WHEN REMOVING THE CLEVIS PINS FROM THE BASE CYLINDER, THE TWO ASSISTANTS MUST SUPPORT THE TABLE TOP. KEEP HANDS AWAY FROM THE TOP OF THE SLIDES, POINT A, FIG. 31 AND FROM BENEATH THE BASE SLIDING MEMBER. AFTER REMOVING THE CYLINDER, STAND CLEAR OF THE TABLE AS THE TWO ASSISTANTS LOWER THE TABLE TOP. FAILURE TO DO THIS COULD RESULT IN SERIOUS PERSONAL INJURY.**
15. **HYDRAULIC OIL IN THIS EQUIPMENT IS UNDER HIGH PRESSURE WHEN EQUIPMENT IS IN OPERATION. NEVER CHECK OR ATTEMPT TO REPAIR ANY OIL LINE WITHOUT FIRST SHUTTING OFF THIS EQUIPMENT AND UNPLUGGING THE POWER CORD.**
16. **BEFORE ATTEMPTING TO REMOVE AND REPLACE A POWER SYSTEM PART, DISCONNECT POWER CORD FROM WALL RECEPTACLE. FAILURE TO DISCONNECT POWER CORD COULD RESULT IN PERSONAL INJURY.**
17. **THE LOCATOR PIN ON THE BACK OF THE TIME DELAY RELAY MUST BE IN THE HOLE ON THE CONTROL PANEL. FAILURE TO DO THIS COULD RESULT IN ELECTRICAL SHOCK.**
16. **DO NOT ATTEMPT ELECTRICAL CONTINUITY CHECKS OR ANY WIRING TESTS WITH THE TABLE PLUGGED INTO THE WALL OUTLET. FAILURE TO DISCONNECT POWER CORD COULD RESULT IN ELECTRICAL SHOCK.**

19. WHEN CHANGING TABLE PANEL OR SWITCHES NOTE HOW WIRES ARE POSITIONED SO THAT THEY MAY BE REPLACED EXACTLY THE SAME WAY OR DAMAGE TO THE WIRES MAY OCCUR RESULTING IN ELECTRICAL SHOCK OR EQUIPMENT DAMAGE.
20. WHEN CHANGING A HOSE NOTE HOW THE WIRES, HOSES, HOSE FITTINGS, AND NYLON TIES ARE POSITIONED SO THAT THEY MAY BE REPLACED EXACTLY THE SAME WAY OR DAMAGE TO THE WIRES AND HOSES MAY OCCUR RESULTING IN ELECTRICAL SHOCK OR EQUIPMENT DAMAGE.
21. MOTOR PUMP AND BRACKET ARE ISOLATED FROM THE GROUNDING CONDUCTOR OF THE SUPPLY CORD. WHEN SERVICING USE ONLY IDENTICAL REPLACEMENT PARTS.

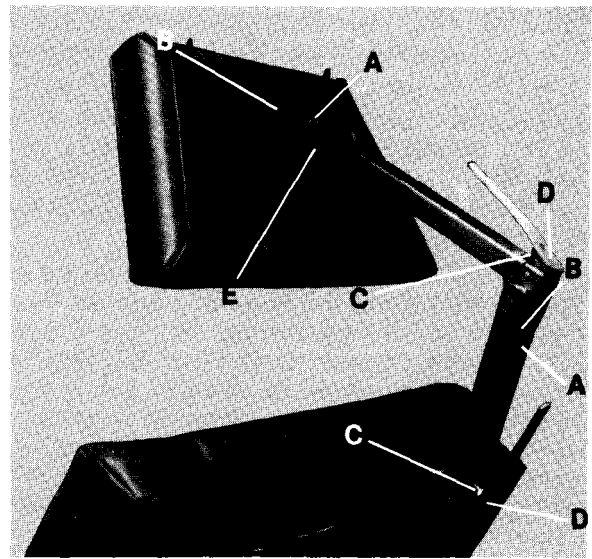

Fig. 1

Note: Light oil on the pivot points of the handle will help to a great degree the ease of operation of the handle.

In some rare cases, it may be necessary to adjust the handle stop to insure good holding power with ease of handle operation or to prevent the handle from springing loose under shock loads.

For proper action the handle stop must be adjusted so that when the handle is pushed down for locking action, the handle reaches a point where it wants to lock itself by suddenly going over center. The proper position of the stop is just a fraction over center. The stop is adjusted by loosening the lock nut Item C, Fig. 1 and turning the set screw stop Item D, Fig. 1 with a 1/8" allen wrench. After adjustment, lock the stop screw with the lock nut.

Model 112: To adjust the holding action of the headlock, release the lock handle and loosen the lock screw Item A, Fig. 2 using a 3/32" allen wrench. With a 3/16" allen wrench, tighten the adjusting screw Item B, Fig. 2 to obtain the greatest possible holding power without making the handle operation too difficult. Then with the handle in the locked position, tighten the lock screw.

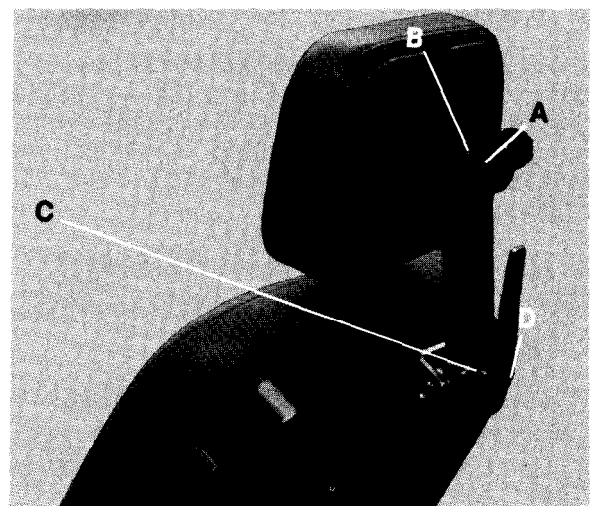

Fig. 2

INTRODUCTION

This manual covers complete instructions for the service and maintenance of the Model 111 Medical Examination Table, Model 112 Special Procedures Table, Model 113 Special Procedures Chair, and Model 114 Power Podiatry Chair.

All models are similar in operation. All subjects covered pertain to all models unless otherwise specified. For the purpose of this manual, the word **table** is synonymous with the word **chair**.

PARTS REPLACEMENT

The Model 111, 112, 113, and 114 examination tables have been designed so that mechanical and electrical components can easily be repaired and/or replaced in the field if they should become defective for any reason.

If a part replacement should be required, the part must be ordered direct from the factory. When any part is ordered, a complete description or part number is required, along with Serial Number and date of installation of the table must be supplied. For details of the exchange plan, write the plant. (For location of serial number tags for Model 111 & 114 see Item B, Fig. 4, and for Models 112 & 113 see Item B, Fig. 4A).

HEADLOCK ADJUSTMENT

Model 111: To adjust the holding action of the headlock, release the lock handle and loosen the lock screw Item A, Fig. 1, using a 3/32" allen wrench. With a 3/16" allen wrench or a 1/2" wrench, tighten the adjusting screw, Item B, Fig. 1, to obtain the greatest possible holding power without making the handle operation too difficult. Then with the handle in locked position, tighten the lock screw.

Note: Light oil on the pivot points of the handle will help to a great degree the ease of operation of the handle.

In some rare cases, it may be necessary to adjust the handle stop to insure good holding power with ease of handle operation or to prevent the handle from springing loose under shock loads.

For proper action the handle stop must be adjusted so that when the handle is pushed down for locking action, the handle reaches a point where it wants to lock itself by suddenly going over center. The proper position of the stop is just a fraction over center. The stop is adjusted by loosening the lock nut Item C, Fig. 2 and turning the set screw stop Item D, Fig. 2 with a 1/8" allen wrench. After adjustment, lock the stop screw with the lock nut.

Articulating Headrest With Quick Change Pin: The articulating headrest is equipped with a quick change pin to allow **interchangability** with any **Midmark** optional headrest. To remove the headrest pull downward on handle, Fig.3 Item A. Grasping pin by knob, press inward. Turn knob 90° to disengage from locking slot. Pull pin from headlock & headrest. Remove headrest and substitute desired option, reverse procedure to install.

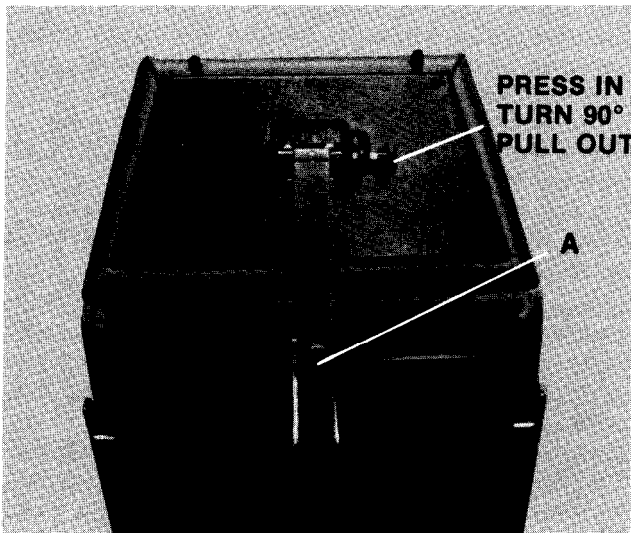

Fig. 3

If quick change pin will not pull out of headlock, loosen lockscrew, Item A, Fig. 1 & 2, and loosen adjusting screw, Item B, Fig. 1 & 2, until pin will slide out. Readjust adjusting screw so that headlock will hold when locked but pin will slide out when unlocked.

REMOVAL AND REPLACEMENT OF UPHOLSTERED SECTIONS

Model 111,114

Removal of Headrest Upholstery Section

- 1) Remove the (4) screws, Item E, Fig. 1, which mount the headrest to the brackets of the headlock.

Replacement of Headrest Upholstery Section

- 1) Install the (4) # 10-24 x 5/8" screws through the metal brackets of the headlock and into the headrest. Tighten screws semi tight.
- 2) Align headrest square with back section and tighten screws securely.

Removal of Seat & Back Upholstery Section

- 1) Remove the metal panel from the metal back frame by removing (4) small screws. Item A, Fig. 4.

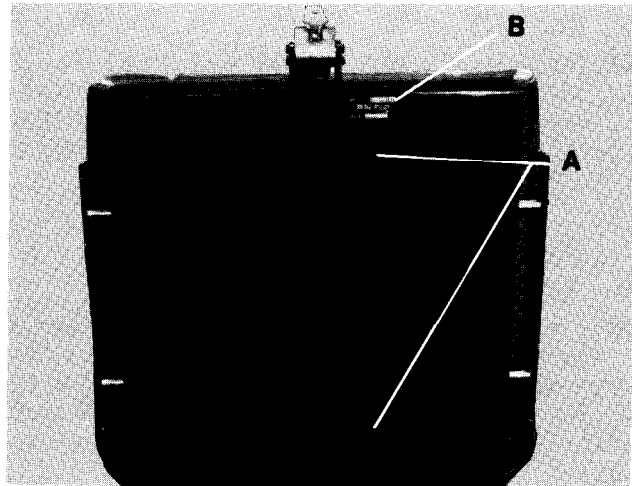

Fig. 4

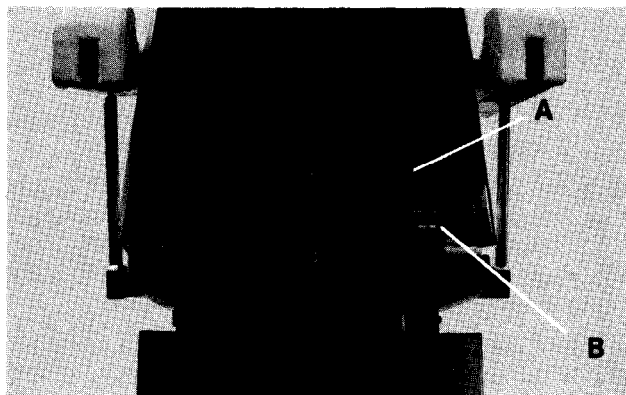

Fig. 4A

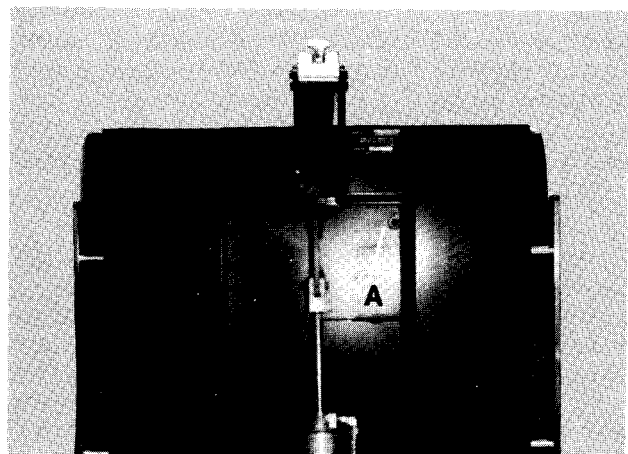

Fig. 5

- 2) Remove the (4) screws located inside the recessed area of the metal back frame. (Item A, Fig. 5)
- 3) Remove the (2) screws located at the front edge of the seat section. (Item A, Fig. 6) It is easiest to do this with the leg extension raised up.
- 4) Remove the (2) screws located under the seat section, near the hinge, by inserting a screwdriver through access hole, item B, Fig. 6.
- 5) On the 114 Only, remove the (4) wood screws located under the front outer edge of the seat section. Item A, Fig. 7.
- 6) With an assistant, lift the entire seat and back section.

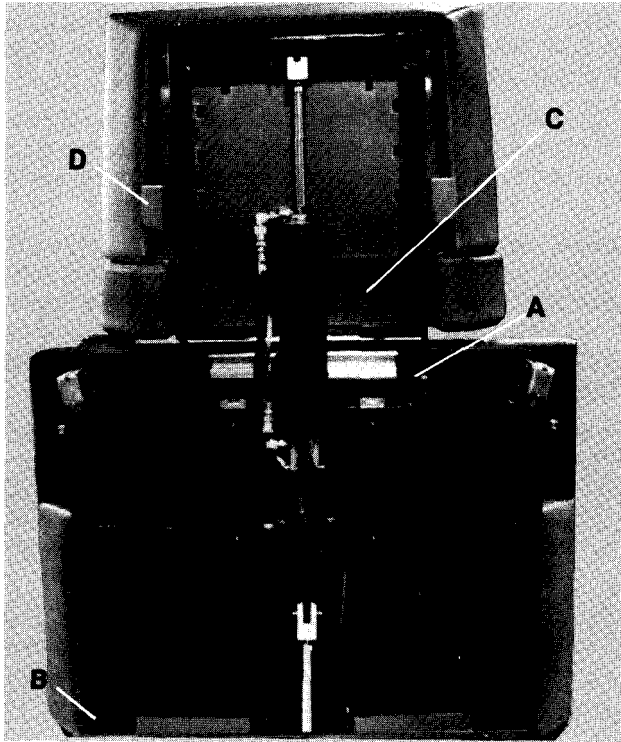

Fig. 6

Replacement of Seat and Back Upholstery Section

- 1) With an assistant, place the seat and back upholstery section on the metal frame.
- 2) Align front holes under seat section, Item A, Fig. 6 and install (2) # 10-24 x 5/8" screws. It is easiest to do this with leg extension raised up.
- 3) With a magnetic screwdriver, install (2) # 10-24 x 5/8" screws through the access holes. item B, Fig. 6.
- 4) Align holes on back section and install (4) # 10-24 x 5/8" screws. Item A, Fig. 5.
- 5) On the 114 Only, install (4) wood screws under outer front edge of seat section, Item A, Fig. 7

Removal of Legrest Upholstered Section (111 Only)

- 1) Raise foot extension up, remove (2) # 10-24 x

7/8" screws under the legrest frame, Item C, Fig. 6.

- 2) Lift off unholstered legrest.

Replacement of Legrest Upholstered Section (111 Only)

- 1) With legrest extension raised up, place legrest upholstered section on the legrest frame.
- 2) Align holes and install (2) # 10-24 x 7/8" screws under the legrest frame, Item C, Fig. 6.

Removal of Footrest Upholstered Section (111 Only)

- 1) Remove footrest from table by lifting lever, Item D., Fig. 6 and pulling footrest toward you.

DANGER: DO NOT ATTEMPT TO REMOVE THE LEVER MECHANISM FROM THE UNDERSIDE OF THE FOOTREST. REMOVING THE LEVER MECHANISM COULD RESULT IN PERSONAL INJURY.

- 2) Return entire footrest to factory for replacement of upholstery.

Replacement of Footrest Upholstered Section (111 Only)

- 1) When placing the footrest section in the position shown in Fig. 6, the metal guides should be inserted into the slots until you hear the mechanical locking device engage.

DANGER: FAILURE TO LOCK THE FOOTREST SECTION INTO POSITION COULD RESULT IN PERSONAL INJURY OR EQUIPMENT DAMAGE.

Removal of Footrest Upholstered Section (114 Only)

- 1) Remove screw Item B, Fig. 7, from lateral locking mechanism to expose (4) mounting screws.
- 2) Remove (4) mounting screws from each side of frame, Item C, Fig. 7.
- 3) Pull upholstered section to its full extended position and lift.
- 4) Remove (4) # 10-24 x 5/8" screws from upholstered foot section.

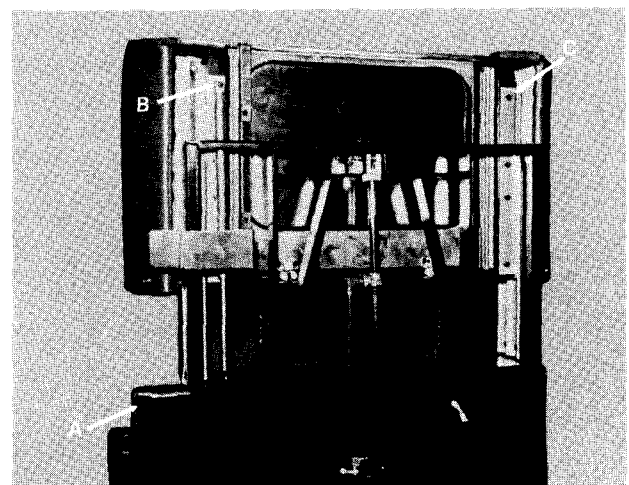

Fig. 7

Replacement of the Footrest Upholstered Section (114 Only)

- 1) Place footrest upholstered section on frame and align holes and install (4) # 10-24 x 5/8" screws in footrest upholstered section.
- 2) Install (4) mounting screws on each side of frame, Item C, Fig. 7.
- 3) Install screw, Item B, Fig. 7 in lateral locking mechanism.

Removal of Upholstering on Model 112 & 113

- 1) With the exception of the Model 113 Chair Arms, all upholstery is secured with Velcro patches. To remove an upholstery section, grasp at the extreme end of part and lift slowly. Fig. 8.

Replacement of Upholstering on Model 112 & 113

- 1) To replace upholstery, position table in horizontal position. Locate upholstery over corresponding table section and press into place. Cycle table to check for proper fit at pivot points.

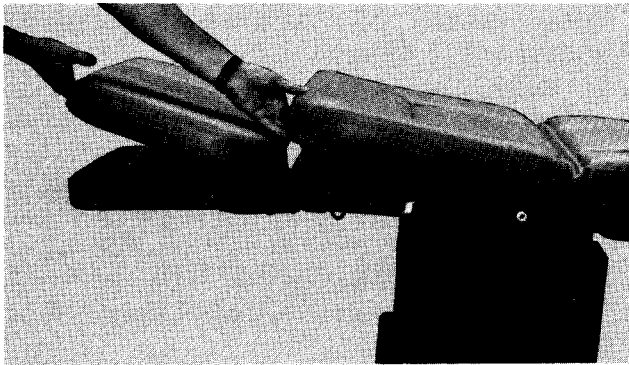

Fig. 8

Removal of Upholstering on Model 113 Chair Arms

- 1) To remove chair arm upholstery, position arm to allow convenient access to Phillips screws on bottom cover. Remove (2) # 6 Self Tapping Phillips screws from metal cover on bottom of arm, Item A, Fig. 9. Remove bottom cover.
- 2) Remove (2) # 10-24 x 1/2 Phillips Machine Screws, Item B, Fig. 9. Lift upholstery from chair arm.

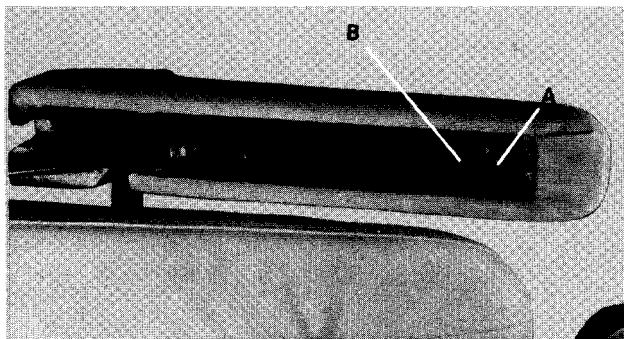

Fig. 9

Replacement of Upholstering on Model 113 Chair Arms

- 1) To replace chair arm upholstery, position upholstery over metal arm. Align upholstery over two holes in metal arm. Install (2) # 10-24 x 1/2 Machine Screws. Item B, Fig. 9.
- 2) Position bottom cover under upholstery. Secure to metal arm with (2) # 6 Self Tapping Phillips Screws. Item A, Fig. 9.

REMOVAL AND REPLACEMENT OF TABLE PANELS

- 1) Raise to its highest position.

DANGER: DISCONNECT POWER CORD FROM WALL RECEPTACLE. FAILURE TO DISCONNECT POWER CORD COULD RESULT IN PERSONAL INJURY.

- 2) Remove motor cover, rear outer shroud (motor end), and front outer shroud (foot end). See Motor Cover and Shroud Removal on Page 7.

DANGER: WHEN CHANGING TABLE PANEL OR SWITCHES NOTE HOW WIRES ARE POSITIONED SO THAT THEY MAY BE REPLACED EXACTLY THE SAME WAY OR DAMAGE TO THE WIRES MAY OCCUR RESULTING IN ELECTRICAL SHOCK OR EQUIPMENT DAMAGE.

Removal of Panel Assembly From Table and Panel From Shrouds

- 3) Pull panel away from table and remove (3) # 10 Phillips screws, Item A, Fig. 10, located on bottom flange. Lay panel down flat next to table.
- 4) Remove back cover from receptable and switches by removing (4) # 6 Phillips Screws. Item A, Fig. 11. Remove wire raceway by removing (6) Phillips Screws. item B, Fig. 11.
- 5) Remove (3) # 6 Phillips Screws from corners of wood panel. Item C, Fig. 11.

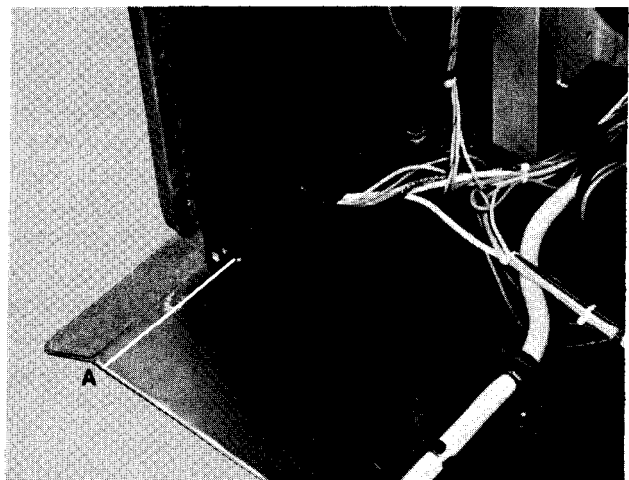

Fig. 10

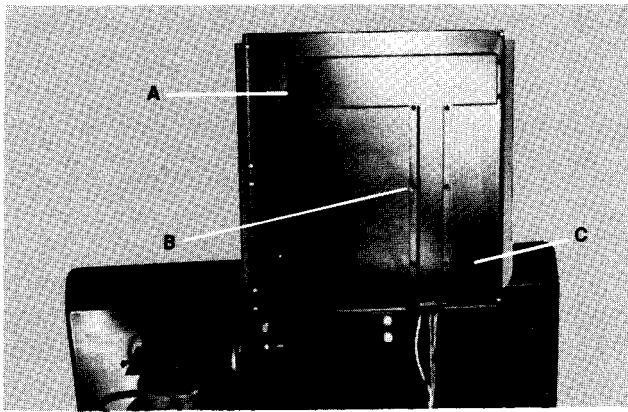

Fig. 11

Removal of Auto Return and Stop Switches

- 6) Remove panel assembly and shroud as described in steps 1 through 4.
- 7) Remove wiring from switch by pulling wire quick disconnect terminal from switch back terminals.
- 8) Squeeze switch mounting clips together and work switch out by alternately pushing each side of the switch. A flat screwdriver can be used to help push the switch out. See Item A, Fig. 12.

Removal of Receptacle

- 9) Remove panel assembly and shrouds as described in steps 1 through 4.

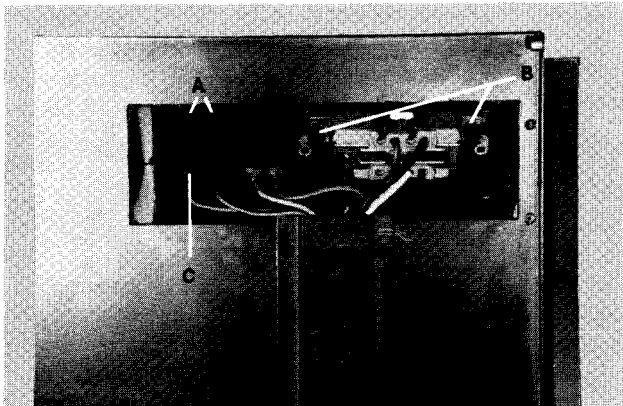

Fig. 12

- 10) Remove (2) # 8 lock nuts, Item B, Fig. 12 using a 11132 nut driver.
- 11) Remove (1) # 6 flat head screw from front of panel.
- 12) Pull receptacle out of panel and remove wiring.

Removal of Nameplate

- 13) Remove shrouds, switches, and receptacle as described in steps 1 through 12.
- 14) Pry nameplate from panel using a putty knife or other flat tool.
- 15) Clean panel surface using solvent such as alcohol or paint thinner.

Replacement of Auto Return or Stop Switches

- 16) Push switch into panel with switch terminals

located at bottom of switch. See Item C, Fig. 12. Push switch in until chrome bezel touches nameplate.

- 17) Reconnect wiring by pushing quick disconnect wire terminals onto switch terminals. Do not bend switch terminals. For wire location, see wiring diagram, Pg. 31.
- 18) Test switch operation to make sure it moves freely in and out.

Replacement of Receptacle

- 19) Position receptacle on (2) # 8 weld studs.
- 20) Reconnect wiring by inserting ends of wires into holes in back of receptacle. For wire location, see wiring diagram, Pg. 31.
- 21) Push receptacle onto weld studs so it is sticking through nameplate.
- 22) Replace (2) # 8 lock nuts onto weld studs using a 11132 nut driver. See Item B, Fig. 12.
- 23) Replace (1) # 6 flathead Phillips screw in front of panel through nameplate into receptacle.

Replacement of Shrouds to Panel and Panel Assembly to Table

- 24) Replace auto return and stop switches, and receptacle per steps 16 through 23. Check wire connection locations and route wires so they do not touch switches.
- 25) Replace shroud to panel. Align holes and install (3) # 6 Phillips screws, Item C, Fig. 16.
- 26) Replace wire raceway. Align wires so none are pinched and install (6) # 6 Phillips screws. Item B, Fig. 11.

DANGER: WHEN REPLACING THE WIRE RACEWAY, BE SURE ALL WIRES ARE CONFINED WITHIN RACEWAY. FAILURE TO CONTAIN WIRES COULD RESULT IN PERSONAL INJURY OR EQUIPMENT DAMAGE.

- 27) Replace back cover on switches and receptacle. Check wire routing so that no wires interfere with switch mounting and terminals. Install (4) # 6 Phillips screws, Item A, Fig. 11.
- 28) Check operation of switches to make sure they move freely in and out.
- 29) Place panel assembly on table base, align holes, and install (3) # 10 Phillips screws. Item A, Fig. 10.

REMOVAL AND REPLACEMENT OR MOTOR COVER, CONTROL BOX COVER AND SHROUDS

DANGER: DISCONNECT POWER CORD FROM WALL RECEPTACLE BEFORE REMOVING OR REPLACING MOTOR COVER AND SHROUDS. FAILURE TO DISCONNECT POWER CORD COULD RESULT IN PERSONAL INJURY.

Motor Cover

- 1) Remove motor cover by removing (6) screws, Item A, Fig. 13, and pulling bottom of cover out until top of cover disengages from retaining channel.

- 2) Replace motor cover by inserting top of cover into retaining channel, Item B, Fig 13, and pushing bottom of cover in until top is fully engaged in channel. Align holes and install (6) # 10 x 3/8" screws, Item A, Fig. 13.

DANGER: WHEN REPLACING THE MOTOR COVER, BE SURE ALL WIRES AND HOSES ARE INSIDE OF COVER. FAILURE TO DO THIS COULD RESULT IN ELECTRICAL SHOCK OR EQUIPMENT DAMAGE.

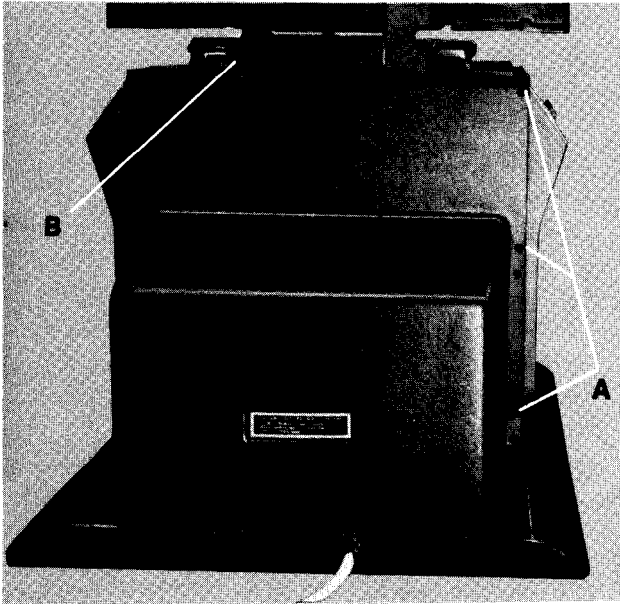

Fig. 13

**Rear Outer Shroud
(Motor End)**

- 1) Remove rear outer shroud by removing (4) screws, Item A, Fig. 14.
- 2) Replace rear outer shroud by placing shroud in position as shown in Fig. 14, aligning holes, and installing (4) # 6 x 3/8" screws, Item A, Fig. 14.

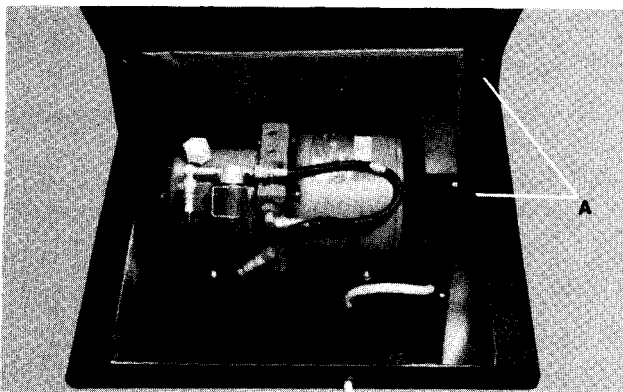

Fig. 14

**Rear Inner Shroud
(Motor End)**

- 1) Remove rear inner shroud by removing (8) screws, Item A, Fig. 15.
- 2) Replace rear inner shroud by placing shroud in position as shown in Fig. 15, aligning holes, and installing (8) # 6 x 3/8" screws, Item A, Fig. 15.

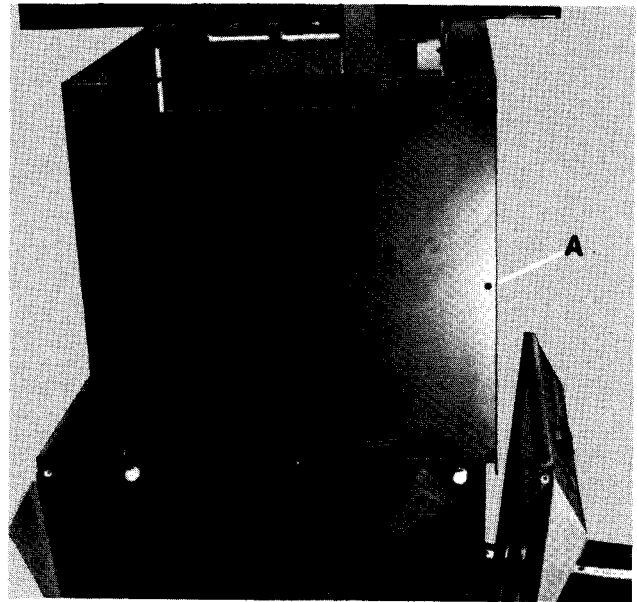

Fig. 15

**Front Outer Shroud
(Foot End)**

- 1) Remove front outer shroud by removing (4) # 6 32 x 3/8" screws, Item A, Fig. 16. Lift shroud from foot switch cord.
- 2) Replace front outer shroud by placing shroud in position as shown in Fig. 16, aligning holes and installing (4) # 6-32 x 3/8" screws, Item A, Fig. 16.

Note: Footswitch cord is to be routed through slot in front outer shroud. Split bushing on cord should be pressed into place after shroud installation.

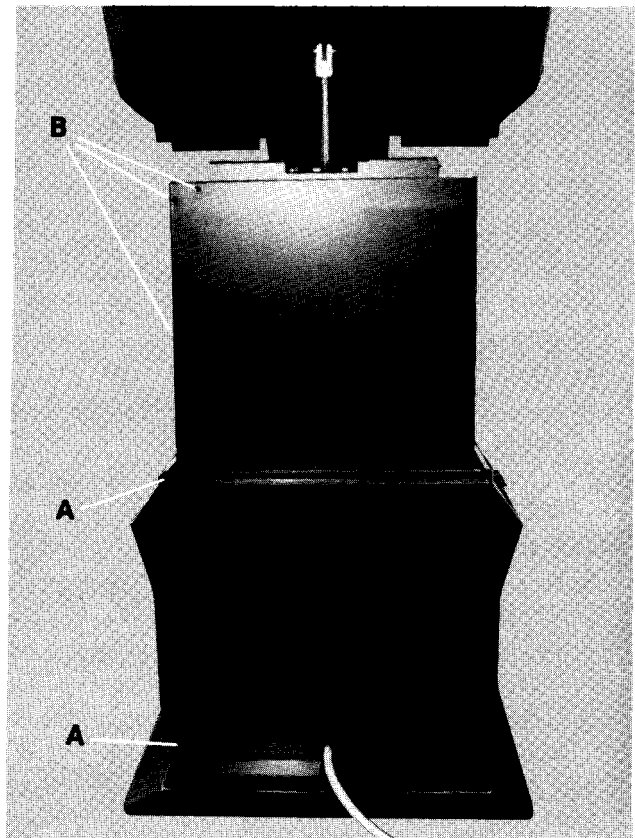

Fig. 16

Front Inner Shroud (Foot End)

- 1) Remove front inner shroud by removing (8) screws, Item B, Fig. 16.
- 2) Replace front inner shroud by placing shroud in position as shown in Fig. 16, aligning holes, and installing (8) # 6 x 3/8" screws, Item B, Fig. 16.

CONTROL BOX COVER

The control box cover is located under the motor cover at the rear of the table. See removal and replacement of Motor Cover on page 7. The enclosure covers all major electrical connections on the table.

- 1) Remove the control box cover by removing (4) # 6-32 x 3/8" screws, Item A, Fig. 17, and (2) # 10-24 x 3/8" Self Tapping Screws, Item B, Fig. 17. Lift the Control Box Cover from the Control Box.
- 2) Replace the Control Box cover by placing the cover in position as shown in Fig. 17, aligning holes and installing (4) # 6-32 screws, Item A, Fig. 17, and (2) # 10-24 x 3/8" Self Tapping Screws, Item B, Fig. 17.

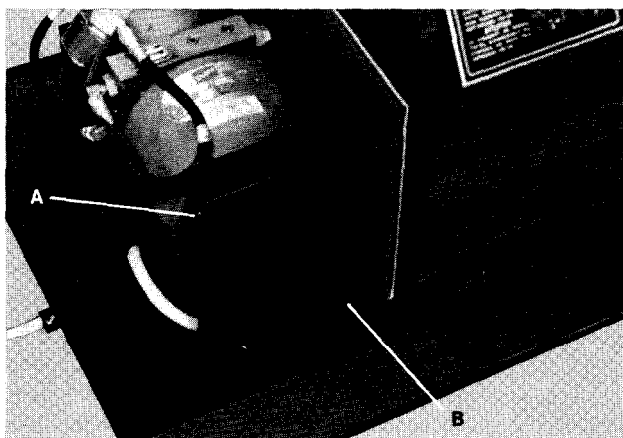

Fig. 17

REMOVAL AND REPLACEMENT OF RUBBERIZED TREAD

The rubberized tread on the tapered sides of the table base may be replaced by:

- 1) Remove tread by grasping end of tread and peeling off of table base.
- 2) Remove all foreign material from base where tread is to be applied.
- 3) Peel off paper backing on new tread, place tread in position, and firmly press on tread making sure all edges adhere to the base.

Note: Base surface must be clean and dry before application of new tread.

POWER SYSTEM OPERATION AND MAINTENANCE

The power system consists of three basic sub

assemblies:

- 1) An electric motor coupled to a hydraulic pump with an attached oil reservoir.
- 2) Four hydraulic cylinders with built-in electric solenoid valves. (Three hydraulic cylinders on Model 113)
- 3) A foot control footswitch assembly.

When the control switch, either Table Up, Back Up, Tilt Up, or Foot Up is depressed, it opens a solenoid valve in the cylinder and simultaneously energizes the motor which pumps oil from the reservoir into the bottom of the respective cylinder. This extends the pistons of the cylinder to the desired length. When the control switch is released, the motor stops and the solenoid valve closes automatically locking the cylinder piston in that position. When the control switch, either Table Down, Back Down, Tilt Down, or Foot Down is depressed, the solenoid valve is again opened and simultaneously the motor reverses which pumps oil from the reservoir into the top of the cylinder and retracts the piston to the desired length. When the control switch is released, the motor stops and the solenoid valve closes automatically locking the cylinder piston in that position.

The solenoid valves are built into the cylinders, eliminating the high pressure condition in the hoses when the motor is not running. This feature reduces the number of components subjected to high pressure when the motor is not running.

The motor, pump and reservoir of the power system are enclosed in a sounddeadened housing located on the base plate.

HYDRAULIC SYSTEM

The hydraulic oil used in the Model 111, 112, 113, & 114 power system is a colorless, odorless, nonstaining LIGHT GRADE mineral oil. This is the same grade of mineral oil as available from any hospital stockroom or pharmacy.

The unit is filled at the factory and should never need refilling unless fluid is lost through an external leak. No bleeding or purging of the hydraulic hoses is required. Any air that may reach the cylinder during shipment or during repairs will return to the reservoir after a short period of operation.

Adding Oil to Hydraulic System

DANGER: DISCONNECT POWER CORD FROM WALL RECEPTACLE. FAILURE TO DISCONNECT POWER CORD COULD RESULT IN PERSONAL INJURY.

- 1) Remove motor cover. See Motor Cover Removal on Page 7.
- 2) Remove plastic filler cap, Item A, Fig. 18, on top of tank.
- 3) Remove small screw, Item B, Fig. 18, from end of tank and place a rag under this screw hole.
- 4) Fill tank with a **LIGHT GRADE** of mineral oil until oil starts to run out of small screw hole.

- 5) Replace small screw, Item B, Fig. 18, in end of tank.
- 6) Replace plastic filler cap, Item A, Fig. 18.
- 7) Replace motor cover. See Replacement of Motor Cover on Page 7.

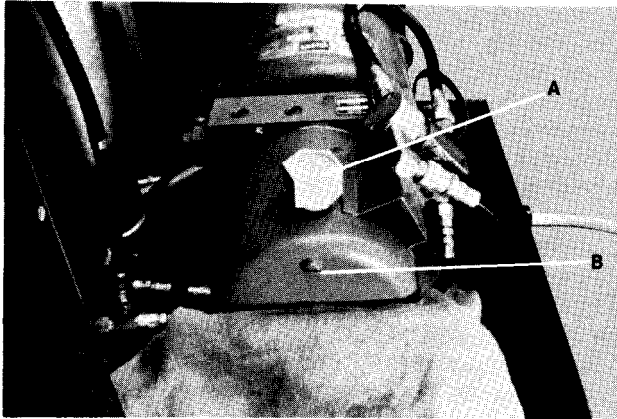

Fig. 18

Oil Leaks

DANGER: HYDRAULIC OIL IN THIS EQUIPMENT IS UNDER HIGH PRESSURE WHEN EQUIPMENT IS IN OPERATION. NEVER CHECK OR ATTEMPT TO REPAIR ANY OIL LINE WITHOUT FIRST SHUTTING OFF THIS EQUIPMENT AND UNPLUGGING THE POWER CORD.

Oil leaks can be caused by defective or damaged hose lines, hose or pipe fittings, "O" rings, or cylinder rod seals. If an oil leak appears in any area, determine exact location of leak.

- 1) If a leak is located at a pipe fitting, tighten the fitting a turn or two. If this does not eliminate the leak, back the fitting out and use pipe sealer on the threads. If the threads are damaged, replace the fitting.
- 2) If a leak is located at a pipe fitting in a cylinder, try tightening the fitting. If this does not eliminate the leak, replace the "O" ring.
To replace the "O" ring, remove the hose fitting from the cylinder and remove the defective "O" ring. Place a new "O" ring in position, install the hose fitting, and tighten fitting securely.
- 3) If a leak is located at a hose fitting, try tightening the fitting. If this does not eliminate the leak, remove the fitting and check the flare on the fitting. If the flare is good on the hose check the pipe fitting. Replace defective part.

Cylinder Leaks

If a cylinder is leaking, replace the cylinder. See Removal and Replacement of Hydraulic Cylinders on pages 14 through 18.

Hose Line Leaks

If a hose line is leaking, remove and replace that hose section. No longer must the total assembly be replaced.

DANGER: DISCONNECT POWER CORD FROM WALL RECEPTACLE. FAILURE TO DISCONNECT POWER CORD COULD RESULT IN PERSONAL INJURY.

DANGER: WHEN CHANGING A HOSE, NOTE HOW THE WIRES, HOSES, HOSE FITTINGS, AND NYLON TIES ARE POSITIONED SO THAT THEY MAY BE REPLACED EXACTLY THE SAME WAY OR DAMAGE TO THE WIRES AND HOSES MAY OCCUR RESULTING IN ELECTRICAL SHOCK OR EQUIPMENT DAMAGE.

- 1) Remove covers from suspected area of leak.
 - a. Removal of motor cover and shrouds on Page 7.
 - b. Removal of back cover. Remove (4) screws, Item A, Fig. 4 or 4A.
 - c. Removal of base brace. Remove (4) 3/8"-16 x 7/8" Hex Bolts and (4) 3/8" Lockwashers.
- 2) Examine hoses to find location of leak. If excessive oil on hose lines make leak source difficult to locate, clean all surfaces with rag, cycle table once. Examine hose lines for leak.
- 3) After determining source of leak, place new hose along side of damaged hose before removing defective hose. (See identification of hoses following this section.)
- 4) Remove fittings, using 7/16" and 9/16" wrenches, and nylon ties of defective hose, one at a time, replacing with fittings of new hose and nylon ties.
- 5) After installation of new hose, check to see that all cords and hoses work freely and are clear of obstructions and that all fittings are tight.
- 6) Temporarily plug the power cord into an electrical outlet and extend and retract each cylinder several times to purge the system of air.

DANGER: DISCONNECT POWER CORD FROM WALL RECEPTACLE. FAILURE TO DISCONNECT POWER CORD COULD RESULT IN PERSONAL INJURY.

- 7) If loss of hydraulic fluid was excessive during repair, oil must be added to the system. Oil level should be checked and oil replenished if required. See Adding Oil to Hydraulic System on Page 9.
- 8) Replace any shrouds or covers removed for access to leaking hose.

HOSE IDENTIFICATION

002-0125-00
POWER HOSE KIT
(Tilt to Back)

002-0126-00
RETURN HOSE KIT
(lift to Back)

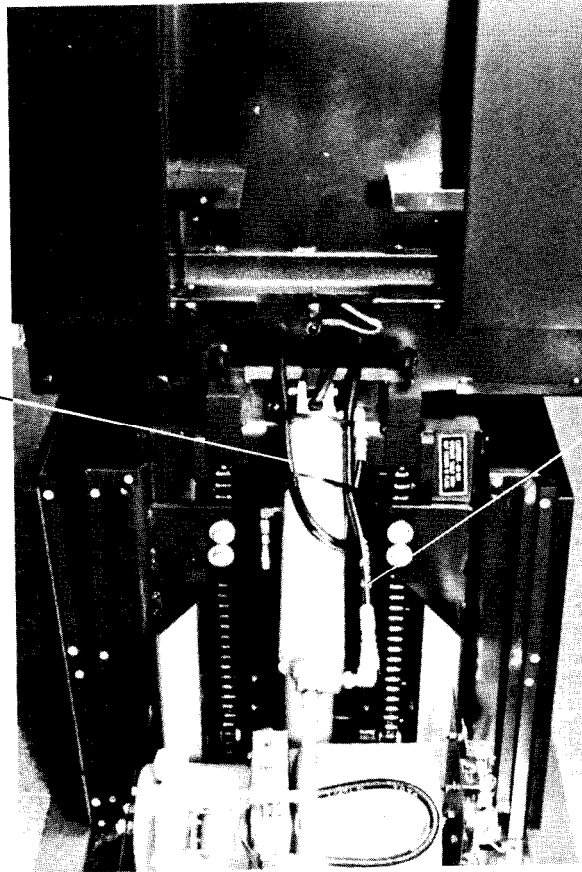

Fig. 19

002-0120-00
RETURN HOSE KIT
(Base Cylinder)

002-0118-00
RETURN HOSE KIT
(Pump to Base)

002-0119-00
POWER HOSE KIT
(Pump to Base)

002-0117-00
PUMP HOSE KIT

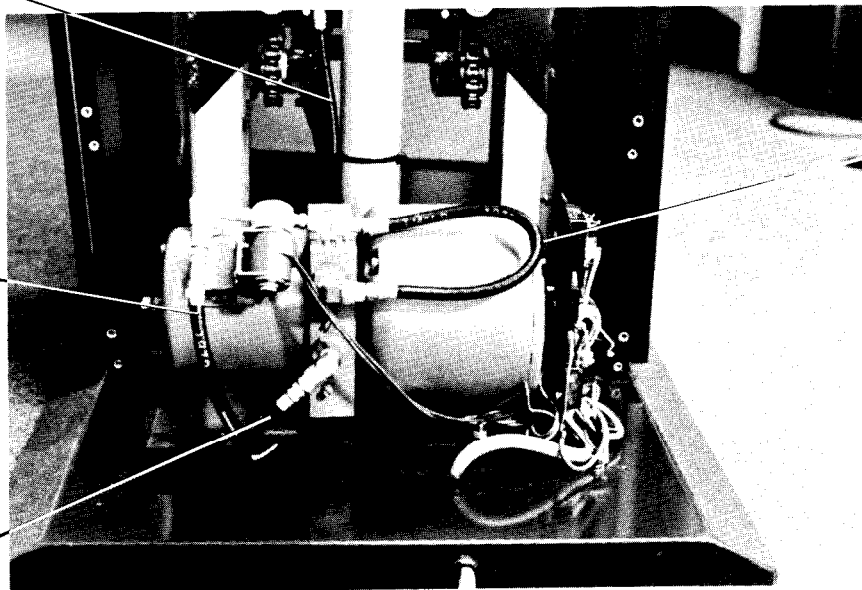
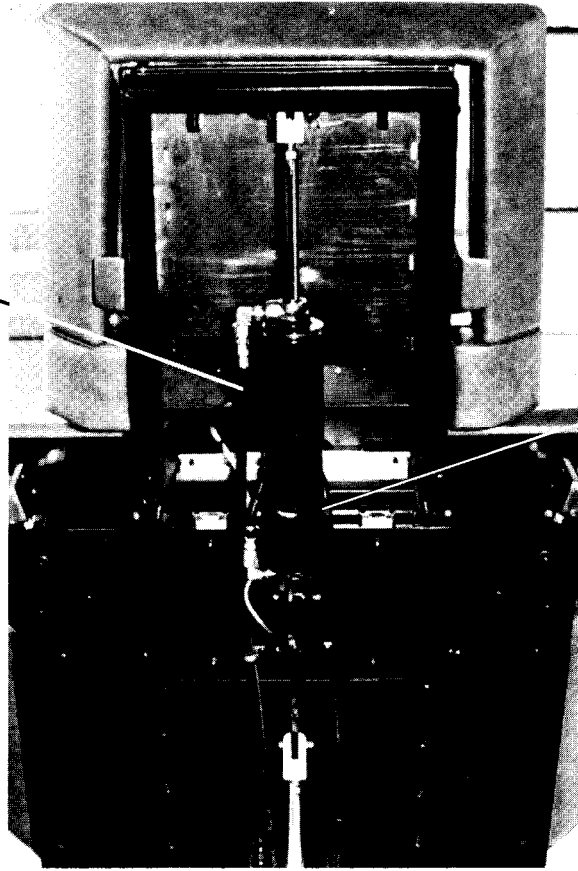

Fig. 20

HOSE IDENTIFICATION

002-0124-00
RETURN HOSE KIT
(*Tilt to Foot)



002-0123-00
POWER HOSE KIT
(Tilt to Foot)

Fig. 21

002-0126-00
RETURN HOSE KIT
(Tilt to Back)

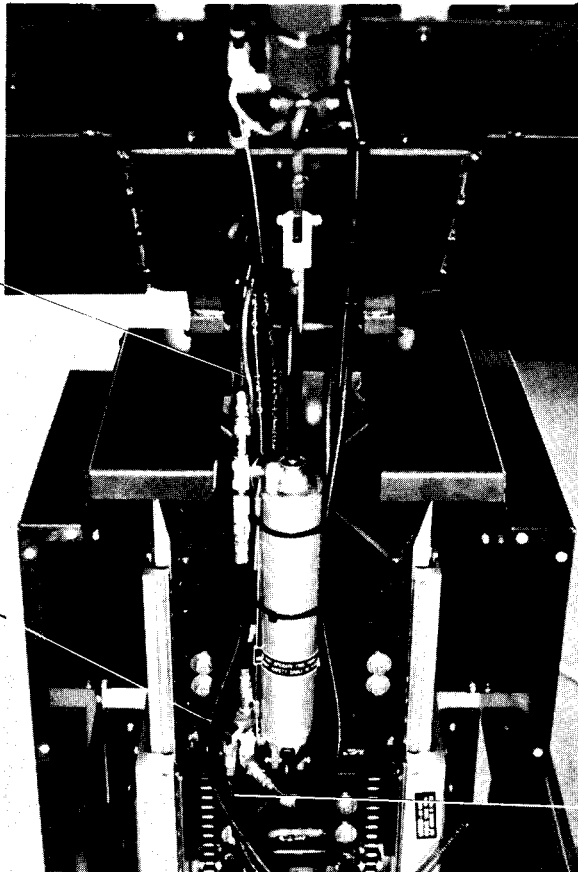

002-0122-00
RETURN HOSE KIT
(Base to Tilt)

002-0121-00
POWER HOSE KIT
(Base to Tilt)

Fig. 22

HOSE IDENTIFICATION

CAPACITOR

002-0121-00
POWER HOSE KIT
(Base to Tilt)

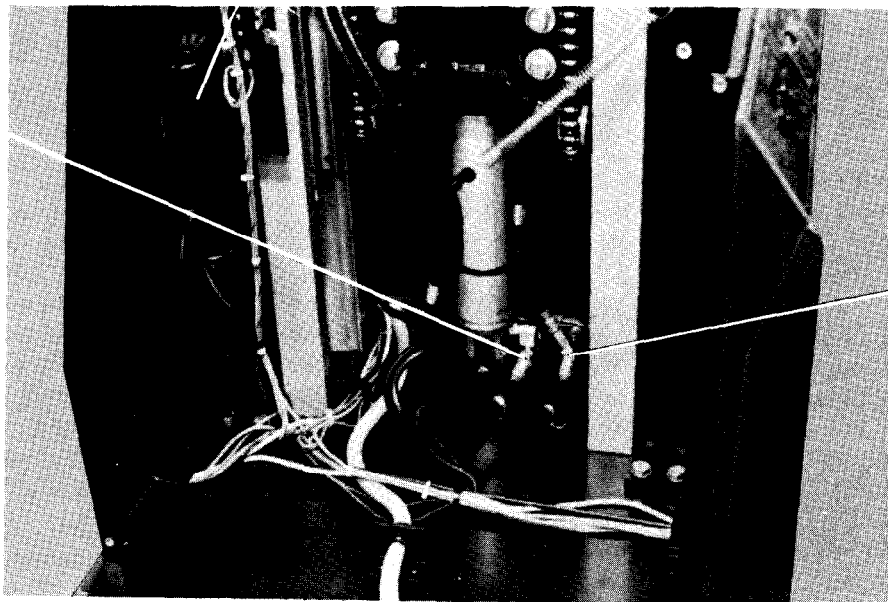

002-0122-00
RETURN HOSE KIT
(Base to Tilt)

Fig. 23

All hoses have part numbers marked on a silver band wrapped around the hose body. These numbers can be used to further identify each assembly.

| Kit Number | contains | Hose Assembly |
|------------------------|----------|------------------------|
| 002-0118-00 | | 014-0104-03 |
| 022-0119-00 | | 014-0104-05 |
| 002-0120-00 | | 014-0104-00 |
| 002-0121-00 | | 014-0104-06 |
| 002-0122-00 | | 014-0104-02 |
| 002-0123-00 | | 014-0104-07 |
| 002-0124-00 | | 014-0104-04 |
| 002-0125-00 | | 014-0104-02 |
| 002-0126-00 | | 014-0104-01 |

REMOVAL AND REPLACEMENT OF HYDRAULIC CYLINDERS

BACK CYLINDER

DANGER: WHEN CHANGING A CYLINDER, NOTE HOW THE WIRES, HOSES, HOSE FITTINGS, AND NYLON TIES ARE POSITIONED SO THAT THEY MAY BE REPLACED EXACTLY THE SAME WAY OR DAMAGE TO THE WIRES AND HOSES MAY OCCUR RESULTING IN ELECTRICAL SHOCK OR EQUIPMENT DAMAGE.

- 1) Remove Motor Cover, Control Box Cover, Front Outer Shroud (Foot End), and Front Inner Shroud (Foot End). See "Motor Cover and Shroud Removal" on page 7.
- 2) Remove Back Cover Shroud from Back Section by removing (4) screws, Item "A", Fig. 4 or 4A, Model 111, 114 & Item A, Fig. 4A, Model 112 & 113.
- 3) With an assistant supporting the Back Section, remove the "E" Ring and Clevis Pin, Item "A", Fig. 24. Let Cylinder hang by clevis.

DANGER: BACK SECTION MUST BE SUPPORTED UNTIL NEW CYLINDER IS INSTALLED. FAILURE TO SUPPORT BACK SECTION COULD RESULT IN PERSONAL INJURY OR EQUIPMENT DAMAGE.

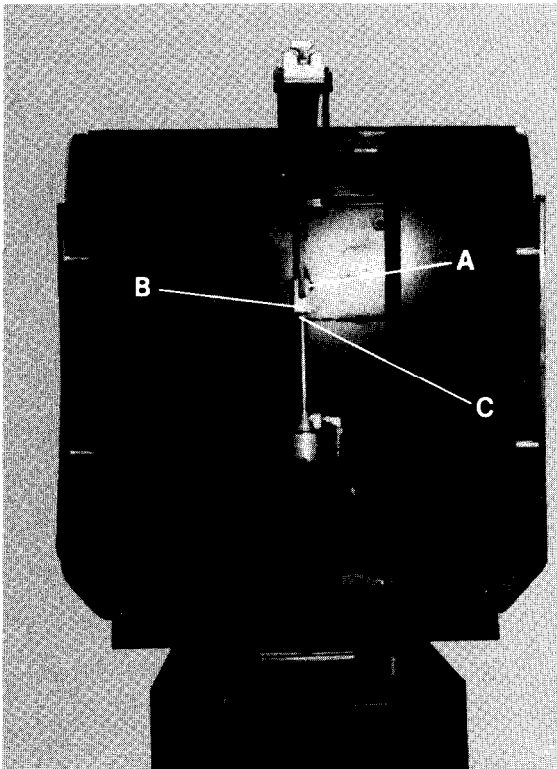

Fig. 24 Model 111 and 114 Shown

- 4) Remove (2) large nylon ties from cylinder, Item "A", Fig. 25.

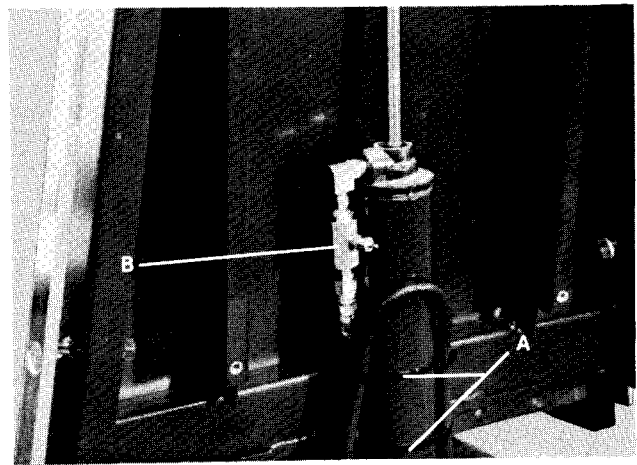

Fig. 25 Model 112 Shown

- 5) Remove the (2) Hose Fittings from the defective cylinder using 9/16" and 7/16" wrenches. On Models 112 & 113 only, a 9116" wrench should be used to remove the needle valve assembly from the rod end port of the defective cylinder, Item B, Fig. 25.

DANGER: BE SURE POWER CORD IS DISCONNECTED FROM WALL RECEPTACLE. FAILURE TO DISCONNECT POWER CORD COULD RESULT IN ELECTRICAL SHOCK.

- 6) Remove "E" ring and clevis pin from valve end of cylinder to remove cylinder from table. Remove elbow from cylinder port and install in new cylinder.
- 7) Allow defective cylinder to hang by cord.
- 8) Place new cylinder in position and install clevis pin and "E" ring at valve end of cylinder.
- 9) Connect hose fittings tightly to new cylinder. (On Models 112 & 113 install needle valve in port on rod end of cylinder, Item B, Fig. 25. Position valve parallel with cylinder body. (Valve stem should point away from table back.) Lay solenoid electric cord along side of hoses.
- 10) Install (2) Nylon Ties, Item "A", Fig. 25 on the cylinder.
- 11) Follow defective cylinder solenoid cord from cylinder to terminal board, noting the placement of nylon ties and clamps.
- 12) Lay new cylinder solenoid cord along side of defective cylinder solenoid cord, replacing ties and clamps-as you remove the defective cylinder cord and replace with new cylinder cord.

DANGER: BE SURE POWER CORD IS DISCONNECTED FROM WALL RECEPTACLE. FAILURE TO DISCONNECT POWER CORD COULD RESULT IN ELECTRICAL SHOCK.

- 13) Remove defective cylinder cord from terminal board and replace with new cylinder cord. See Wiring Diagram on Page 31.

- 14) Temporarily plug the power cord into an electrical outlet and fully extend the back cylinder rod by depressing the "Back Up" footswitch pedal.
- 15) Position the back section and back cylinder as shown in Fig. 24 and install clevis pin and "E" ring, Item A, Fig. 24.
- 16) After installation of new cylinder, check to see that all cords and hoses work freely and are clear of obstructions.
- 17) Position the table as shown in Fig. 26. The table top should be level. If the back section tilts down, then adjust the clevis, Item B, Fig. 24 out. If the back section tilts up, then adjust the clevis, Item "B", Fig. 24 in. To adjust the clevis, turn the cylinder rod using a 3/8" open end wrench. The rod will turn easiest when it is extended about half of its total extension.

DANGER: DISCONNECT POWER CORD FROM WALL RECEPTACLE. FAILURE TO DISCONNECT POWER CORD COULD RESULT IN PERSONAL INJURY.

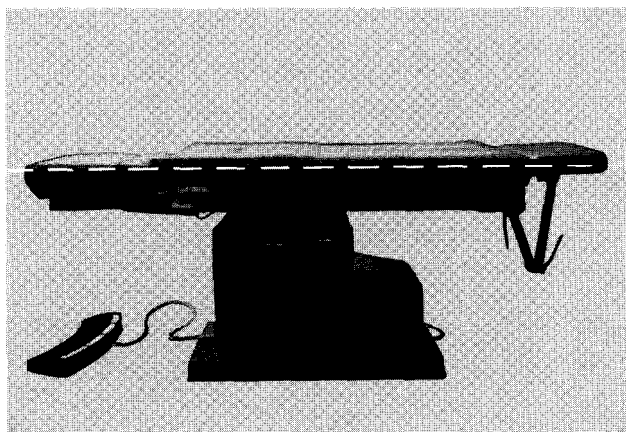

Fig. 26

- 18) If loss of hydraulic fluid was excessive during repair, oil must be added to the system. Oil level should be checked and oil replenished if required. See Adding Oil to Hydraulic System on page 9. Model 112 & 113 tables should take from 9-13 seconds to cycle from horizontal to vertical position. If speed is not to this specification, adjust needle valve. See Adjustment of Needle Valve on page 24.
- 19) Place back cover shroud in position, align holes and install (4) # 6 x 1/4" screws, Item A, Fig. 4, Model 111 & 114, and Items A & B, Fig. 4A, Model 112 & 113.
- 20) Replace shrouds and motor cover. See Replacement of Motor Cover & Shrouds on Page 7.

TILT CYLINDER

DANGER: WHEN CHANGING A CYLINDER, NOTE HOW THE WIRES, HOSES, HOSE FITTINGS, AND NYLON TIES ARE POSITIONED SO THAT THEY MAY BE REPLACED EXACTLY THE SAME WAY OR DAMAGE TO THE WIRES AND HOSES MAY OCCUR RESULTING IN ELEC-

TRICAL SHOCK OR EQUIPMENT DAMAGE. See Fig. 27

DANGER: DISCONNECT POWER CORD FROM WALL RECEPTACLE. FAILURE TO DISCONNECT POWER CORD COULD RESULT IN PERSONAL INJURY.

- 1) Remove motor cover, control box cover, front outer shroud (foot end), and front inner shroud (foot end). See Motor Cover & Shroud Removal on Page 7.
- 2) With an assistant supporting the table top, remove the "E" ring and clevis pin, Item A, Fig. 27.

DANGER: TABLE TOP MUST BE SUPPORTED UNTIL NEW CYLINDER IS INSTALLED. FAILURE TO SUPPORT TABLE TOP COULD RESULT IN PERSONAL INJURY OR EQUIPMENT DAMAGE.

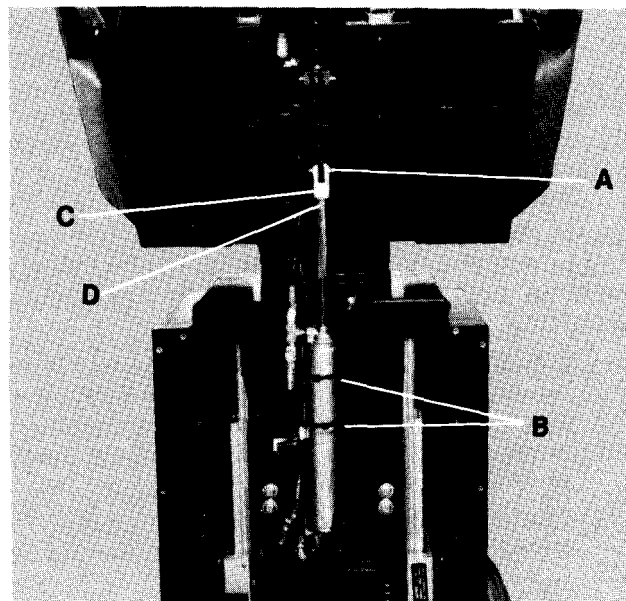

Fig. 27

- 3) Remove the (2) large nylon ties, Item B, Fig. 27, from the cylinder.

DANGER: BE SURE POWER CORD IS DISCONNECTED FROM WALL RECEPTACLE. FAILURE TO DISCONNECT POWER CORD COULD RESULT IN ELECTRICAL SHOCK.

- 4) While supporting the defective cylinder, remove (4) hose fittings from the cylinder using 9/16" and 7/16" wrenches. Remove the "E" ring and clevis pin from valve end of cylinder to remove from the table. Remove fittings from cylinder ports and install in new cylinder making sure safety cable is reinstalled.
- 5) Allow defective cylinder to hang by cord.
- 6) Place new cylinder in position. Install clevis pin and "E" ring at valve end of cylinder and connect hose fittings tightly.
- 7) Install nylon ties, Item B, Fig. 27 on the cylinder.
- 8) Follow defective cylinder solenoid cord from cylinder to terminal board, noting the placement of nylon ties and clamps.
- 9) Lay new cylinder solenoid cord along side of

defective cylinder solenoid cord, replacing ties and clamps as you remove the defective cylinder cord and replace with new cylinder cord.

- 10) Remove defective cylinder cord from terminal board and replace with new cylinder cord. See Wiring Diagram on Page 31.
- 11) Temporarily plug the power cord into an electrical outlet and extend the tilt cylinder rod by depressing the "Tilt Up" footswitch pedal.
- 12) Position the table top and tilt cylinder as shown in Fig. 27 and install clevis pin and "E" ring, Item A, Fig. 27.
- 13) After installation of new cylinder, check to see that all cords and hoses work freely and are clear of obstructions.
- 14) Position the table as shown in Fig. 26. The table top should be level. If the top is not level, the clevis, Item C, Fig. 27, must be adjusted in or out accordingly. To adjust the clevis, turn the cylinder rod using a 3/8" open end wrench on the wrenching flats, Item D, Fig. 27. The rod will turn easiest when it is extended about half of its total extension.

DANGER: DISCONNECT POWER CORD FROM WALL RECEPTACLE. FAILURE TO DISCONNECT POWER CORD COULD RESULT IN PERSONAL INJURY.

- 15) If loss of hydraulic fluid was excessive during repair, oil must be added to the system. Oil level should be checked and oil replenished if required. See Adding Oil to Hydraulic System on Page 9.
- 16) Replace shrouds and motor cover. See Replacements of Motor Cover & Shrouds on page 7.

FOOT CYLINDER (Model 111,112, & 114)

DANGER: WHEN CHANGING THE CYLINDER, NOTE HOW THE WIRES, HOSES, HOSE FITTINGS, AND NYLON TIES ARE POSITIONED SO THAT THEY MAY BE REPLACED EXACTLY THE SAME WAY OR DAMAGE TO THE WIRES AND HOSES MAY OCCUR RESULTING IN ELECTRICAL SHOCK OR EQUIPMENT DAMAGE.

- 1) Position the table as shown in Fig. 28 or 28A by running tilt and foot up.

DANGER: DISCONNECT POWER CORD FROM WALL RECEPTACLE. FAILURE TO DISCONNECT POWER CORD COULD RESULT IN PERSONAL INJURY.

- 2) Remove motor cover, control box cover, front outer shroud (foot end), and front inner shroud (foot end). See Motor Cover & Shroud Removal on Page 7.
- 3) Loosen hose clamps, Item A, Fig. 28 or 28A.

DANGER: BE SURE POWER CORD IS DISCONNECTED FROM WALL RECEPTACLE. FAILURE TO DISCONNECT POWER CORD COULD RESULT IN PERSONAL INJURY.

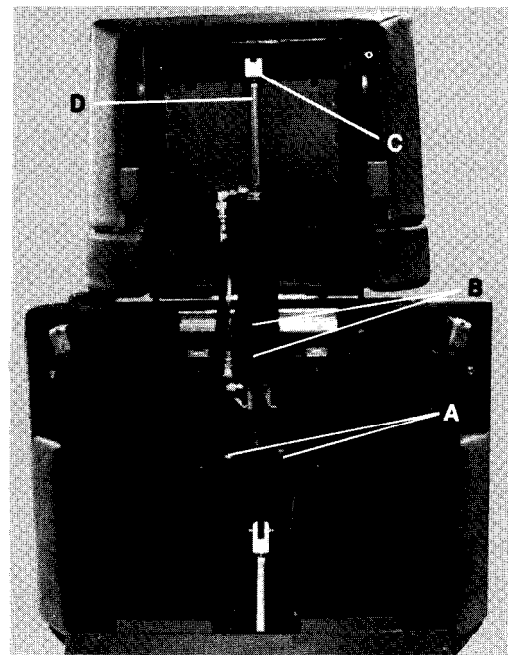

Fig. 28 Model 111 & 114

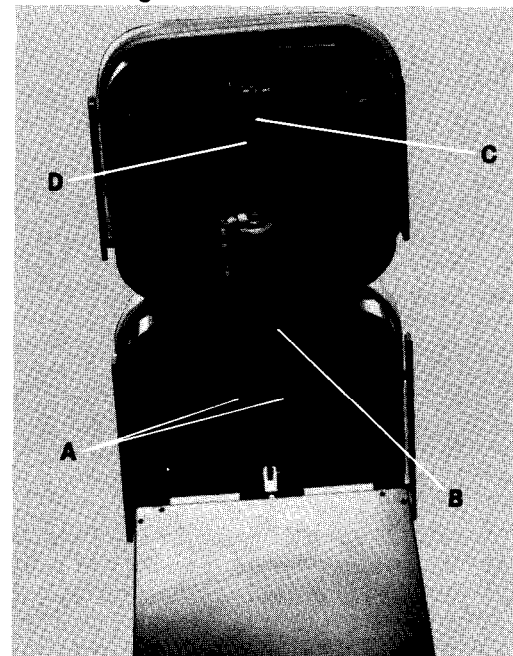

Fig. 28A, Model 112

- 4) Remove (2) cable ties from cylinder, Item B, Fig. 28 or 28A.
- 5) Remove the (2) hose fittings from the defective cylinder using 7/16" and 9/16" wrenches.
- 6) With an assistant supporting the footrest frame, remove the defective cylinder by removing the cotter pin and clevis pin from the rod end of the cylinder and the "E" ring and clevis pin from the valve end of the cylinder. Remove fittings from cylinder port and install in new cylinder.
- 7) Place the new cylinder in position and install the clevis pin and "E" ring at the valve end of the cylinder and the clevis pin and cotter pin at the rod end of the cylinder.
- 8) Connect the hose fittings tightly to new cylinder.
- 9) Follow defective cylinder solenoid cord from

cylinder to terminal board, noting the placement of nylon ties and clamps.

- 10) Lay new cylinder solenoid cord along side of defective cylinder solenoid cord, replacing ties and clamps as you remove the defective cylinder cord and replace with the new cylinder cord.

DANGER: BE SURE POWER CORD IS DISCONNECTED FROM WALL RECEPTACLE. FAILURE TO DISCONNECT POWER CORD COULD RESULT IN ELECTRICAL SHOCK.

- 11) Remove defective cylinder cord from terminal board and replace with new cylinder cord. See Wiring Diagram on Page 31.
- 12) After installation of new cylinder, check to see that all cords and hoses work freely and are clear of obstructions.
- 13) Temporarily plug the power cord into an electrical outlet and position the table as shown in Fig. 26. The table top should be level. If the top is not level, the clevis, Item C, Fig. 28 or 28A, must be adjusted in or out accordingly. To adjust the clevis, turn the cylinder rod using a 3/8" open end wrench on the wrenching flats, Item D, Fig. 28 or 28A. The rod will turn easiest when it is extended about half of its total extension.

DANGER: DISCONNECT POWER CORD FROM WALL RECEPTACLE. FAILURE TO DISCONNECT POWER CORD COULD RESULT IN PERSONAL INJURY.

- 14) If loss of hydraulic fluid was excessive during repair, oil must be added to the system. Oil level should be checked and oil replenished if required. See Adding Oil to Hydraulic System on Page 9.
- 15) Replace shroud and motor cover. See Replacement of Motor Cover & Shrouds on Page 7.

BASE CYLINDER

DANGER: THREE PERSONS ARE REQUIRED TO CHANGE A BASE CYLINDER. TWO PERSONS MUST SUPPORT THE TABLE TOP AS THE THIRD PERSON REMOVES THE CYLINDER. FAILURE TO USE THREE PERSONS COULD RESULT IN PERSONAL INJURY OR EQUIPMENT DAMAGE.

DANGER: WHEN CHANGING A CYLINDER, NOTE HOW THE WIRES, HOSES, HOSE FITTINGS, AND NYLON TIES ARE POSITIONED SO THAT THEY MAY BE REPLACED EXACTLY THE SAME WAY OR DAMAGE TO THE WIRES AND HOSES MAY OCCUR RESULTING IN ELECTRICAL SHOCK OR EQUIPMENT DAMAGE. See Fig. 23 & 29.

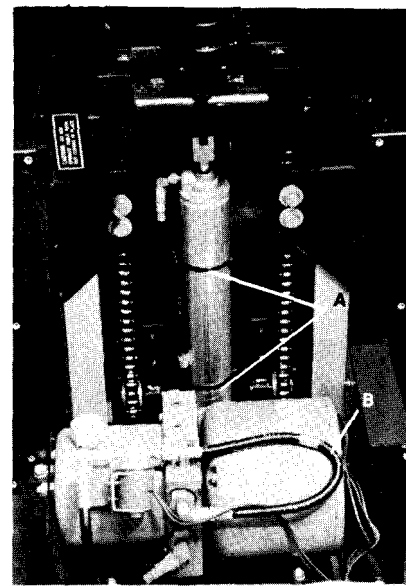

Fig. 29

DANGER: DISCONNECT POWER CORD FROM WALL RECEPTACLE. FAILURE TO DISCONNECT POWER CORD COULD RESULT IN PERSONAL INJURY.

- 1) Remove motor cover, control box cover, rear outer shroud (motor end), and rear inner shroud (motor end). See Motor Cover & Shroud Removal on Page 7.
- 2) Remove brace by removing (4) bolts with a 9/16" wrench.
- 3) Remove large nylon ties, Item A, fig. 29, from cylinder.

DANGER: BE SURE POWER CORD IS DISCONNECTED FROM WALL RECEPTACLE. FAILURE TO DISCONNECT POWER CORD COULD RESULT IN ELECTRICAL SHOCK.

- 4) Follow cylinder solenoid cord to terminal board and remove cord from terminal board.
- 5) With two assistants lifting on the table top at point A, Fig. 30, one assistant on each side of the table:
 - a. Remove the (3) hose fittings from the defective cylinder using 7/16" and 9/16" wrenches.
 - b. Remove cotter pins and clevis pins from each end of cylinder to remove cylinder from table.
 - c. After cylinder is removed from the table, have the assistants slowly lower the table top to its lowest height. Remove fittings from defective cylinder port and install on new cylinder.

DANGER: WHEN REMOVING THE CLEVIS PINS FROM THE BASE CYLINDER, THE TWO ASSISTANTS MUST SUPPORT THE TABLE TOP. KEEP HANDS AWAY FROM THE TOP OF THE SLIDES, POINT A, FIG. 31, AND FROM BENEATH THE BASE SLIDING MEMBER. AFTER REMOVING THE CYLINDER, STAND CLEAR OF THE TABLE AS THE TWO ASSISTANTS LOWER THE TABLE TOP. FAILURE TO DO THIS COULD RESULT IN

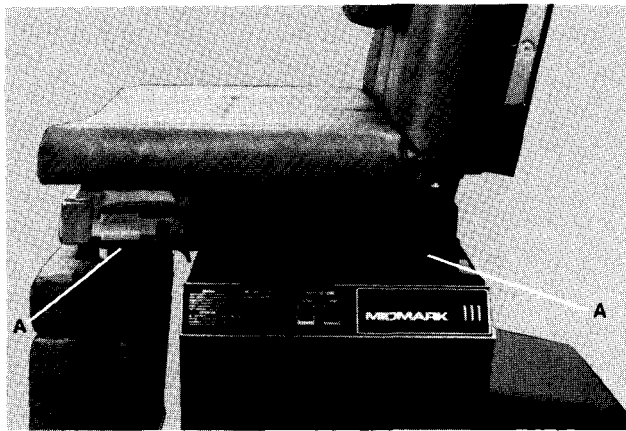

Fig. 30

- 6) Place new cylinder in position and install clevis pin and cotter pin at valve end of cylinder.
- 7) Connect the (3) hose fittings tightly to the new cylinder.
- 8) Have the two assistants lift on the table top enabling the clevis pin, Item B, Fig. 31, to be installed along with the cotter pin.

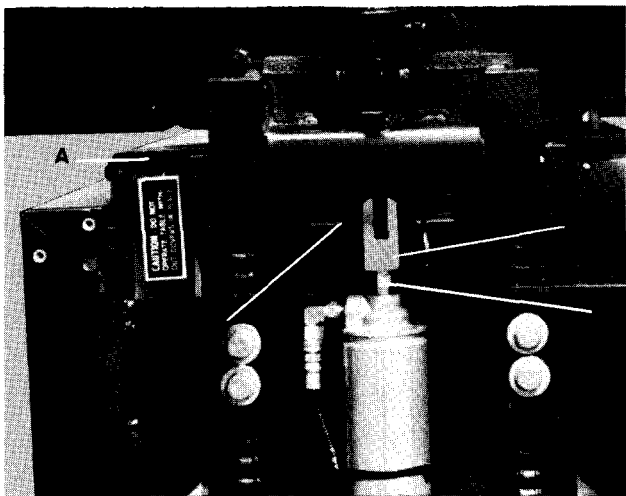

Fig. 31

- 9) Install the large nylon tie, Item A, Fig. 29, on the cylinder.
- 10) Install new cylinder solenoid cord on terminal board. See Wiring Diagram on Page 31.
- 11) Temporarily plug the power cord into an electrical outlet and extend and retract the base cylinder a few times by depressing the "Table Up & Down" footswitch pedals alternately.
- 12) Fully retract the base cylinder and adjust for a 1/16" to 1/8" gap "A", Fig. 31, above the slides. To adjust for this gap, the clevis (rod end) must be adjusted in or out accordingly. To adjust the clevis, turn the cylinder rod using a 3/8" open end wrench on the wrenching flats, Item D, Fig. 31. The rod will turn easiest when it is extended about half of its total ex-

tension.

CAUTION: FAILURE TO ADJUST FOR A 1/16" TO 1/8" GAP AND NO MORE THAN THIS COULD RESULT IN EQUIPMENT DAMAGE.

DANGER: DISCONNECT POWER CORD FROM WALL RECEPTACLE. FAILURE TO DISCONNECT POWER CORD COULD RESULT IN PERSONAL INJURY.

- 13) If loss of hydraulic fluid was excessive during repair, oil must be added to the system. Oil level should be checked and oil replenished if required. See Adding Oil to Hydraulic System on Page 9.
- 14) Replace brace, align holes, and install (4) 3/8" - 16 x 7/8" hex head bolts and (4) 3/8" lockwashers.
- 15) Replace shrouds and motor cover. See Replacement of Motor Cover & Shrouds on Page 7.

LIFT AND STABILIZING CHAIN ADJUSTMENT

Excessive sideways play of the table may be due to loose chains. Chains looseness will be noticed only on the lower portion of the chain loop near the idler sprockets (see Fig. 32). Adjustments may be done as follows:

- 1) Raise the table to the highest position by depressing the "Table Up" footswitch pedal until the table stops rising.

DANGER: DISCONNECT POWER CORD FROM WALL RECEPTACLE. FAILURE TO DISCONNECT POWER CORD COULD RESULT IN PERSONAL INJURY.

- 2) Remove front outer shroud (foot end) and front inner shroud (foot end). See Shroud Removal on Page 8.
- 3) Loosen the (4) bolts, Item A, Fig. 32, with a 9/16" wrench.
- 4) Insert a prybar or large screwdriver in the center of the slot, Item B, Fig. 32, and pry up firmly. While prying up, tighten the (4) bolts, Item A, Fig. 32. The chains should not be drum tight, but with a little spring back and there should be equal tension in both chains.
- 5) Replace front outer shroud and front inner shroud. See Shroud Replacement on Page 8.

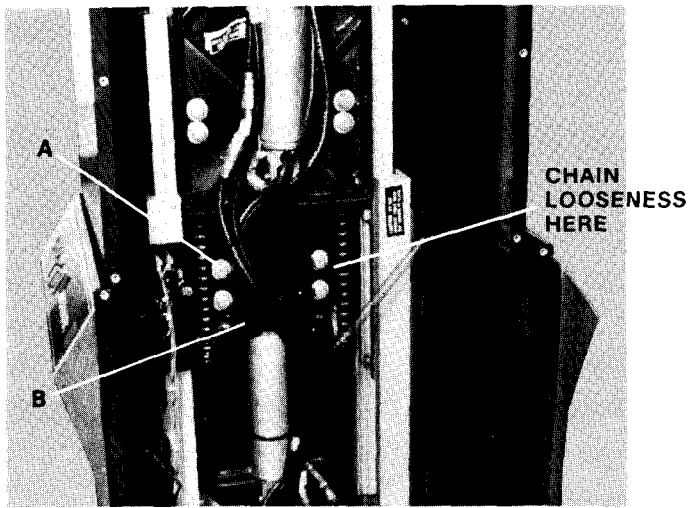

Fig. 32

REMOVAL AND REPLACEMENT OF POWER SYSTEM PARTS

DANGER: BEFORE ATTEMPTING TO REMOVE AND REPLACE A POWER SYSTEM PART, DISCONNECT POWER CORD FROM WALL RECEPTACLE. FAILURE TO DISCONNECT POWER CORD COULD RESULT IN PERSONAL INJURY.

Removal and Replacement of Power Cord

- 1) Remove Motor cover. See "Removal of Motor Cover" on Page 7. Remove control box cover. See "Removal of Control Box Cover" on page 9.
- 2) Remove Strain Relief Bushings, Item "A", Fig. 33, from cord by grasping bushing with hand pliers (See "Special Tools" on Page 24), squeezing tab on bushing, and pulling bushing out of hole in base.

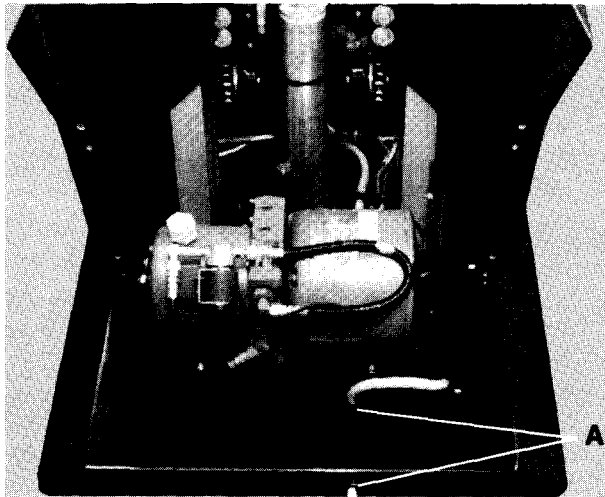

Fig. 33

- 3) Remove the black and white wire of old cord from terminal board, noting the position of the wires.
- 4) Remove (1) screw, securing the green ground wire to the base.

- 5) Before pulling the old cord through the base, bundle the wires together and secure them with a length of string. This string will act as a guide to reinstall the new cord.
- 6) Pull the old cord and string through the base. With the string still running through the base, untie the end securing the wires.
- 7) Bundle the leads of the new power cord together. Tie these ends together with the string running through the base. Gently pull the power cord through the base; disconnect the string.
- 8) Install new power cord by connecting black and white wire to terminal board and installing (1) #10-24 x 3/8 self-tapping screw, through the green grounding wire terminal to secure the ground wire to the table base.
- 9) Position Strain relief bushings on the cord, close the bushings, grasp bushings with hand pliers squeezing the tab, and push bushings into holes in base.
- 10) Replace Motor Cover. See "Replacement of Motor Cover" on Page 7. Replace Control Box Cover. See "Replacement of Control Box Cover" on Pg. 9.

Removal and Replacement of Motor Capacitors

- 1) Remove front outer shroud (foot end) and front inner shroud (foot end). See Removal of Shrouds on Page 8.
- 2) Remove defective capacitor from its bracket (See Fig. 23). Capacitor is held in place by the protusions on each end of the capacitor engaging in a corresponding slot in the bracket.
- 3) Remove cap from defective capacitor.
- 4) Remove the wires from the defective capacitor and install on the new capacitor.
- 5) Place cap on new capacitor and install capacitor in the bracket, making sure the protusions on each end of the capacitor is fully engaged in the slot in the bracket. See Fig. 23.
- 6) Replace shrouds. See Replacement of Shrouds on Page 8.

Removal and Replacement of Anticavitation Solenoid Valve

The anticavitation solenoid valve, Item A, Fig. 34, will prevent cylinder extension when the cylinder solenoid is unenergized.

To remove and replace the anticavitation solenoid valve.

- 1) Remove motor cover. See Removal of Motor Cover on Page 7.
- 2) Remove the solenoid wires from terminal board. See Wiring Diagram on Page 31. See "Removal of Control Box Cover" on Pg. 9.
- 3) Remove (2) hose fittings from the valve.
- 4) Remove anticavitation valve from table by removing (2) screws, Item B, Fig. 34.

- 5) Place new anticavitation valve in position, align holes, and install (2) # 8-32 x 3/8" screws, Item B, Fig. 34.
- 6) Install the (2) hose fittings on the new valve.
- 7) Install the solenoid wires on the terminal board. See Wiring Diagram on Page 31. Replace Control Box Cover. See "Replacement of Control Box Cover" on Page 9.
- 8) If loss of hydraulic fluid was excessive during repair, oil must be added to the system. Oil level should be checked and oil replenished if required. See Adding Oil to Hydraulic System on Page 9.
- 9) Replace motor cover. See Replacement of Motor Cover on Page 7.

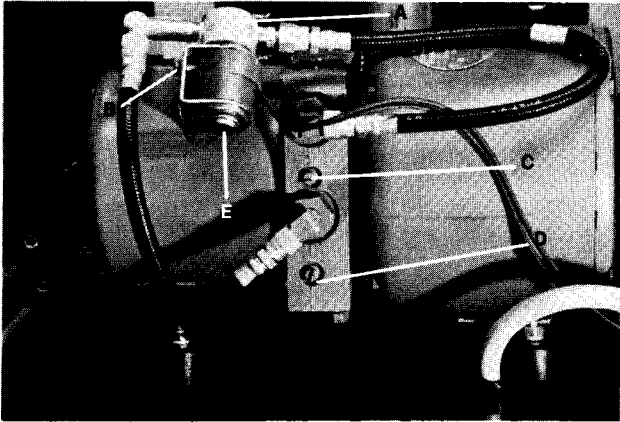

Fig. 34

Removal and Replacement of Time Delay Relay

The time delay relay, Item A, Fig. 35, delays the opening of the cylinder solenoids for 1/10 of a second to avoid momentary drop in up actuations.

To remove and replace the relay:

- 1) Remove motor cover. See Removal of Motor Cover on Page 7.
- 2) Remove control panel cover. See Removal of Control Panel Cover on Page 9.
- 3) Remove defective time delay relay by removing (1) nut and (1) screw, Item B, Fig. 35.
- 4) Place new time delay relay in position, align holes, and install (1) # 6-32 hex nut and (1) # 6-32 x 1" pan head screw, Item B, Fig. 35.

DANGER: THE LOCATOR PIN ON THE BACK OF THE TIME DELAY RELAY MUST BE IN THE HOLE ON THE MOTOR BASE. FAILURE TO DO THIS COULD RESULT IN ELECTRICAL SHOCK.

- 5) Remove wires from defective time delay relay and install on corresponding terminals on new time delay relay. See Wiring Diagram on Page 31.
- 6) Replace control panel cover. See Replacement of control panel cover on page 9.
- 7) Replace motor cover. See Replacement of Motor Cover on Page 7.

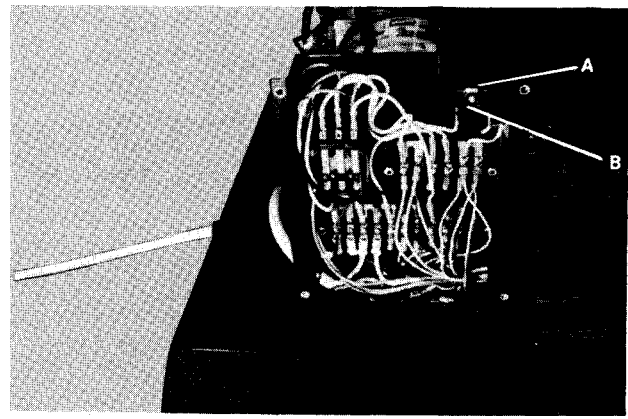

Fig. 35

Removal and Replacement of Motor/Pump

The motor/pump is an integral unit and may be removed and replaced as follows:

- 1) Remove motor cover, front outer shroud (foot end), control panel cover, and front inner shroud (foot end). See Removal of Motor Cover and Shrouds on Page 7.

DANGER: DISCONNECT POWER CORD FROM WALL RECEPTACLE. FAILURE TO DISCONNECT POWER CORD COULD RESULT IN PERSONAL INJURY.

DANGER: MOTOR PUMP AND BRACKET ARE ISOLATED FROM THE GROUNDING CONDUCTOR OF THE SUPPLY CORD. WHEN SERVICING USE ONLY IDENTICAL REPLACEMENT PARTS.

- 2) Remove the (3) motor leads T1, T2, and T3 from terminal board in Control Box. See Wiring Diagram on Page 31 and Removal of Control Box on page 9.
- 3) Remove the capacitors from the brackets and remove the wires from the capacitors. See Removal of Motor Capacitors on Page 19.
- 4) Loosen cable clamps and remove the capacitor leads from the clamps.
- 5) Remove the (4) hex nuts, Item A, Fig. 36, securing the motor base in place.
- 6) Tilt motor base and remove the (2) hex bolts securing the motor/pump to the motor base.
- 7) Loosen the hex nut on the end of the oil reservoir that secures the tank to the motor base.
- 8) Remove the anticavitation solenoid valve from the bracket on the pump. See Removal of Anticavitation Solenoid Valve on Page 19.
- 9) Remove the short pump hose, Item C, Fig. 36, from the pump by removing the fitting with 7/16" & 9/16" wrenches.
- 10) Remove the power hose, Item C, Fig. 36, from the pump by removing the fitting with 7/16" & 9/16" wrenches.
- 11) Lift motor/pump off of the motor base while pulling the motor leads and capacitor leads

through the bushing in the control box.

- 12) Insert motor leads and capacitor leads of new motor/pump through the bushing in the control box.
 - 13) Place new motor/pump on motor base, align holes on the underside and install (2) 1/2" lockwashers and (2) 11/2"-13 x 3/4 hex bolts.
- Note: Be sure the stud on the end of the oil reservoir is in the slot on the end of the motor base.
- 14) Tighten the hex nut on the end of the oil reservoir to secure the tank to the motor base.
 - 15) Replace power hose, Item C, Fig. 36, on pump, tightening the fitting securely with 7/16" and 9/16" wrenches.
 - 16) Replace short pump hose, Item B, Fig. 36, on pump, tightening the fitting securely with 7/16" and 9/16" wrenches.
 - 17) Replace anticavitation solenoid valve. See Replacement of Anticavitation Solenoid Valve on page 19.
 - 18) Place motor base on shock mounts, align holes, and install (4) 1/4" lockwashers and (4) 11/4"-20 hex nuts, Item A, Fig. 36
 - 19) Install cable clamps on capacitor leads and tighten clamps.
 - 20) Install capacitor leads on capacitors and install capacitors in brackets. See Wiring Diagram on Page 31 and Replacement of Capacitors on Page 19.
 - 21) Replace the (3) motor leads T1, T2, and T3 on the terminal board. See Wiring Diagram on Page 31.
 - 22) If loss of hydraulic fluid was excessive during repair, oil must be added to the system. Oil level should be checked and oil replenished if required. See Adding Oil to Hydraulic System on Page 9.
 - 23) Replace motor cover, shrouds, and control panel cover. See replacement of Motor Cover and Shrouds on Page 7.

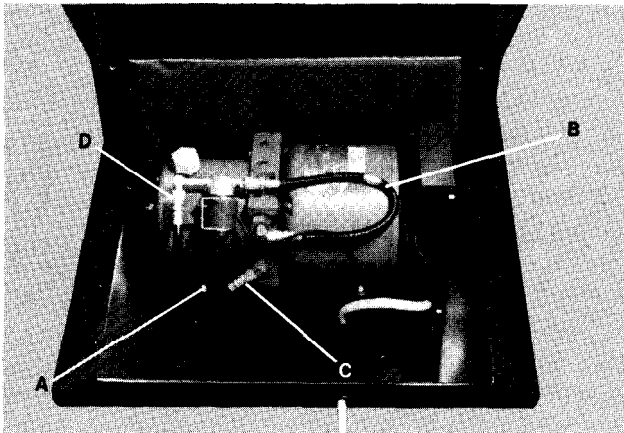

Fig. 36

Auto Return Operation And Maintenance

The auto return system consists of three basic parts.

- 1) The auto return and stop switches located on the table panels.
- 2) The base limit switch located on the table slide assembly.
- 3) The auto return relay located in the table control panel.

When the auto return switch is actuated it energizes the auto return relay. The relay then opens a solenoid valve in the base cylinder and simultaneously energizes the motor which pumps oil into the top of the base cylinder. This retracts the base cylinder and causes the table to lower. The table will continue to lower until it reaches the end of its travel or the auto return stop switch is depressed. When the table reaches the end of its stroke, the base limit switch will deenergize the auto return relay and the motor should stop running. If the auto return stop switch is depressed it will deenergize the auto return relay. This will stop the table at its immediate height by deenergizing the base cylinder solenoid and stopping the motor.

Little routine maintenance is required other than a periodic inspection of wiring.

Removal and Replacement of Auto Return and Stop Switches.

- 1) See step 5 through 7 and step 15 through 17 of removal and replacement of table panel Page 6.

REMOVAL AND REPLACEMENT OF BASE LIMIT SWITCH

Removal of Base Limit Switch

- 2) Raise table to its highest position.

DANGER: DISCONNECT POWER CORD FROM WALL RECEPTACLE. FAILURE TO DISCONNECT POWER CORD COULD RESULT IN ELECTRICAL SHOCK OR PERSONAL INJURY.

- 3) Remove front outer shroud (See Removal of Front Outer Shroud Page 8).
- 4) Remove front inner Shroud (See Removal of Front Inner Shroud, Page 8).
- 5) Remove wires from limit switch, Item A, Fig. 37.

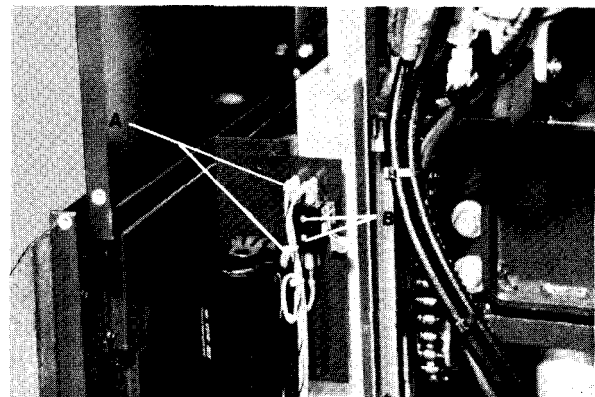

Fig. 37

- 6) Remove (2) # 4 slotted head screws and nuts, Item B, Fig. 37. The switch and actuator can then be removed.

Replacement of Base Limit Switch

- 7) Raise table to its highest position.

DANGER: DISCONNECT POWER CORD FROM WALL RECEPTACLE. FAILURE TO DISCONNECT POWER CORD COULD RESULT IN PERSONAL INJURY OR EQUIPMENT DAMAGE.

- 8) Place switch into actuator as shown in Fig. 37.
- 9) Insert (2) # 4 slotted head screws into switch and actuator and through switch bracket. Screw # 4 nuts on back of screws and tighten.
- 10) Reconnect wires and retie at capacitors. See wiring diagram on Page 31 for correct wiring.

Adjustment of Base Limit Switch

- 11) Remove front outer shroud (See Removal of Front Outer Shroud, Page 8).
- 12) Remove front inner shroud (See Removal of Front Inner Shroud, Page 8).
- 13) Run table to its lowest position.
- 14) Press auto return button so that motor runs.
- 15) Loosen (2) # 4 slotted head screw (Item B, Fig. 37) and slide switch toward the center of the table until motor stops running. Then retighten screws.

DANGER: SWITCH CONNECTIONS ARE ENERGIZED. DO NOT TOUCH OR ELECTRICAL SHOCK COULD OCCUR.

- 16) Raise table up six inches and then push auto return button. Table should go down to lowest position and then motor should stop. If motor doesn't stop redo step 15.
- 17) Replace front inner shroud (See page 8.)
- 18) Replace front outer shroud (See page 8.)

REMOVAL AND REPLACEMENT OF AUTO RETURN RELAY

The auto return relay actuates the base cylinder and motor pump to make the table retract to its lowest position.

To remove and replace the relay:

DANGER: DISCONNECT POWER CORD FROM WALL RECEPTACLE. FAILURE TO DISCONNECT POWER CORD COULD RESULT IN PERSONAL INJURY.

- 1) Remove motor cover. See Removal of Motor Cover Page 7.
- 2) Remove control panel cover. See Removal of Control Panel Cover Page 9.
- 3) Remove defective auto return relay by removing (2) # 6-32 hex nuts with a 5116" nutdriver.

DANGER: WHEN REMOVING THE WIRES FROM THE AUTO RETURN RELAY NOTE THE POSITION OF THE WIRES SO THAT THEY MAY BE REPLACED ON THE SAME TERMINALS. FAILURE TO DO THIS COULD RESULT IN EQUIPMENT DAMAGE OR PERSONAL INJURY.

- 4) Remove the (10) wires from the auto return relay and install on corresponding terminals on new auto return relay. See wiring diagram on Page 31.
- 5) Replace auto return relay into control box and install (2) # 6-32 hex nuts with a 5116" nutdriver.
- 6) Replace control panel cover. See Replacement of Control Panel Page 9.
- 7) Replace motor cover. See Replacement of Motor Cover Page 7.

FOOTSWITCH

Removal and Replacement of Footswitch

DANGER: DISCONNECT POWER CORD FROM WALL RECEPTACLE. FAILURE TO DISCONNECT POWER CORD COULD RESULT IN PERSONAL INJURY.

To remove the footswitch from the cord.

- 1) Remove cover from bottom of footswitch by removing (7) # 10 Phillips headscrews.
- 2) Disconnect cord by pulling apart (7) quick disconnect wire connectors, Item A, Fig. 38, and removing (2) # 10 taptite screws at the base of the cord bracket, Item B, Fig. 38.
- 3) Hold cord bracket and grasp strain relief bushing, Item C, Fig. 38, with hand pliers (See Special Tools on Page 24.) Squeeze tab on bushing and pull bushing from bracket.

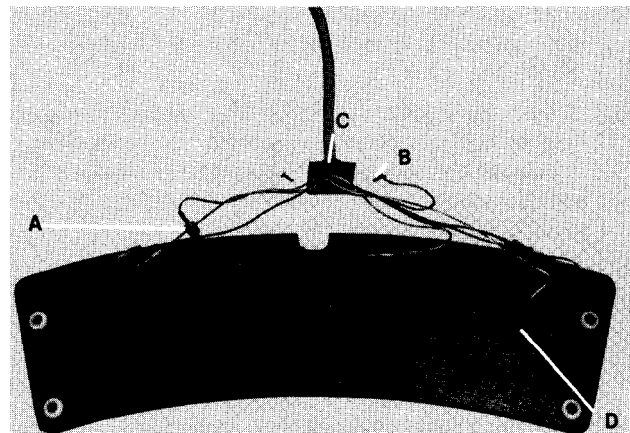

Fig. 38

To replace footswitch cord.

- 4) Position strain relief bushing on end of cord, close bushing, grasp bushing with hand pliers and push bushing into bracket.
- 5) Connect cord to footswitch wires by mating (7) quick connect wire connectors matching the wire colors on the cord wires and footswitch wires.
- 6) Install (1) # 10 Taptite self tapping screw through the green grounding terminal of the footswitch through an external tooth lockwasher, through the footswitch bracket and screw into the footswitch casting. Insert the other # 10 Taptite screw and lockwasher through the other hole in the bracket into the casting.

- 7) Place cover on footswitch, align holes, and install (7) # 10 Phillips headscrews.

REMOVAL AND REPLACEMENT OF FOOT CONTROL MODULE

Removal of Footswitch Module

DANGER: DISCONNECT POWER CORD FROM WALL RECEPTACLE. FAILURE TO DISCONNECT POWER CORD COULD RESULT IN PERSONAL INJURY.

- 1) Remove (2) # 10 Phillips flathead screws from back of footswitch which hold the module, Item D, Fig. 38.
- 2) Tip switch module out of footswitch casting and remove (1) # 10 Phillips panhead screw from end of foot pedal, Item A, Fig. 39.
- 3) Lift up end of pedal and slide forward to remove. This will expose the foot control switches and wiring.
- 4) Remove all wiring from foot control switches.
- 5) Remove split bushing from end of module where wires pass through.
- 6) Pull wires through hole in module. Remove module from casting.

Replacement of Foot Control Module

- 7) Place module into footswitch casting.
- 8) Rout wires through hole in module.
- 9) Insert split bushing into wire hole.
- 10) Connect wiring to foot control switches. See wiring diagram on Page 31 for correct Wire location.
- 11) Tip module out of casting and slip foot pedal cover onto pivot on front of switch bracket. Push down back of pedal, align holes, and insert (1) # 10 Phillips headscrew with pivot bushing, Item B Fig. 39, into hole and tighten.

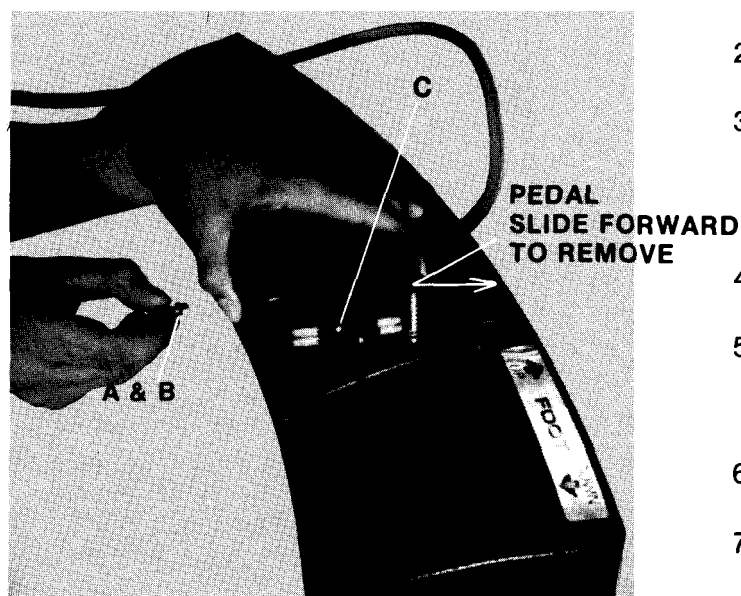

Fig. 39

- 12) Insert foot module ass'y into footswitch casting. Hold module and flip footswitch over.
- 13) Align two mounting holes and insert (2) # 10 Phillips flathead screws and tighten, Item D, Fig. 38.

Removal and Replacement of Foot Control Switches

DANGER: DISCONNECT POWER CORD FROM WALL RECEPTACLE. FAILURE TO DISCONNECT POWER CORD COULD RESULT IN PERSONAL INJURY.

- 1) Remove footswitch module on page 22, steps 1 through 3.
- 2) Remove wiring from damaged foot control switch.
- 3) Remove (2) # 3 slotted head screws and nuts from switch, Item C, Fig. 39. Pull switch from bracket.

Replacement of Foot Control Switch

- 4) Place switch into switch bracket and insert (2) # 3 slotted head screws into switch. Place (2) # 3 shakeproof lock washers and (2) # 3 nuts onto screws and tighten, Item C, Fig. 39.
- 5) Connect wiring to switch. See wiring diagram, page 31, for correct wire location.
- 6) Replace foot pedal onto switch bracket. See Replacement of Foot Control Module, Page 23, Step 12 through 14.

Removal and Replacement of Footswitch Cord

DANGER: DISCONNECT POWER CORD FROM WALL RECEPTACLE. FAILURE TO DISCONNECT POWER CORD COULD RESULT IN PERSONAL INJURY.

- 1) Remove motor cover, front outer shroud (foot end), and front inner shroud (foot end). See Removal of Motor Cover & Shrouds on Page 7. Remove Control Box Cover. See Removal of Control Box Cover on Page 9.
- 2) Remove footswitch from cord. See Removal of Footswitch on page 22.
- 3) Remove strain relief bushing, Item C, Fig. 38, from cord by grasping bushing with hand pliers (See Special Tools on Page 24), squeezing tab on bushing, and pulling bushing out of hole in bracket.
- 4) Lay new footswitch cord along side of defective cord.
- 5) Remove wires of defective cord from terminal board and replace with wires of new cord, removing and replacing one wire at a time. See Wiring Diagram on Page 31.
- 6) Follow defective cord, removing and replacing on new cord any nylon ties and cable clamps.
- 7) Insert new cord through bracket (See Fig. 38) and install strain relief bushing using the hand pliers, (See Special Tools on Page 24).
- 8) Install cord in footswitch. See Replacing Footswitch on Cord on Page 22.

- 9) Replace motor cover and shrouds. See Replacement of Motor Cover & Shrouds on Page 7. Replace Control Box Cover. See Replacement of Control Box Cover on Page 9.

ADJUSTMENT OF FLOW CONTROLS

There are two flow controls on the pump to regulate the time for cylinder extension and cylinder retraction. These flow controls are set and locked in place at the factory and should not need adjustment. Should it ever become necessary to adjust the speed of the table use the following procedure:

“Up” Flow Control (Item C, Fig. 34). The “up” Flow control is adjusted for a time of 13 seconds to raise the table to its highest position from its lowest position.

- 1) Loosen the locknut.
- 2) Turn set screw in a clockwise direction to decrease speed of table movement.
- 3) Turn setscrew in a counterclockwise direction to increase speed of table movement.
- 4) Adjust setscrew for an “up” time of 13 seconds.

“Down” Flow Control (Item D, Fig. 34). The “down” flow control is adjusted for a time of 12 seconds to lower the table from its highest position to its lower position.

- 1) Loosen the locknut.
- 2) Turn setscrew in a clockwise direction to decrease speed of table movement.
- 3) Turn setscrew in a counterclockwise direction to increase speed of table movement.
- 4) Adjust setscrew for a “down” time of 12 seconds.

ADJUSTMENT OF NEEDLE VALVE - MODEL 112 AND 113 ONLY

There is a needle valve on the rod end of the back cylinder to regulate extension and retraction speed of this function only, Item B, Fig. 25. This needle valve is set and locked into place at the factory and should not need adjustment. Should it ever become necessary to adjust the speed of the back cylinder, use the following procedure.

- 1) Loosen the locknut.
- 2) Turn set screw in a clockwise direction to decrease speed of back and counterclockwise to increase the speed of the back.
- 3) Adjust table back speed for a 9-13 second time for horizontal to full vertical position.

SPECIAL TOOLS

Hand Pliers (Fig. 38) is used to remove and install the strain relief bushings. These pliers are manufactured by Heyman Manufacturing Co. and are available through their sales office in Waukesha, Wisconsin. When ordering, specify No. 29 Hand Pliers, Heyco **Part# 0022**.

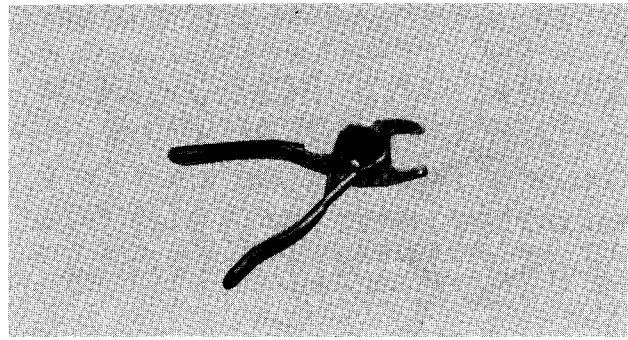

Fig. 40

TROUBLE SHOOTING GUIDE

Many service problems are due to minor problems in the electrical circuits or control switches. Therefore when testing inoperative units, always check switches and electrical wiring first.

A wiring diagram follows this troubleshooting guide and referral to it during troubleshooting will be helpful.

Conditions which could cause improper functioning of the power unit are listed below along with diagnosis and repair procedures.

DANGER: DO NOT ATTEMPT ELECTRICAL CONTINUITY CHECKS OR ANY WIRING TESTS WITH THE TABLE PLUGGED INTO THE WALL OUTLET. FAILURE TO DISCONNECT POWER COULD RESULT IN ELECTRICAL SHOCK.

| Problem | Symptom | Probable Cause | Check | Correction |
|---|---|--|---|--|
| When all up and down switches are depressed individually, table will not actuate into any up or down positions. | Motor does not run and no cylinder to solenoid actuation (audible click). | Unit not plugged in to wall receptacle. | Check. | Plug unit into wall receptacle. |
| | | Blown Fuse. | Check building fuse. | Replace building fuse if blown. |
| | Motor does not run and no cylinder solenoid actuation (audible click). | Black wire of foot-switch cord broken or disconnected or black wire within footswitch broken or disconnected or defective micro-switch in foot-switch control. | Check continuity of black wires. Check for continuity of micro-switch. | Replace footswitch cord if faulty. Replacy black jumper wires in foot-switch if faulty. Replace defective microswitch. |
| | Motor does not run but cylinder solenoids actuate (audible click). | Capacitor burned out or loose terminals. | Check terminals. | Replace defective capacitor and/or tighten connections. |
| | | Motor thermal overload switched on. | Allow motor to cool and recheck. | Do not run motor continuously. |
| | Motor does not run but motor hum is audible and cylinder solenoids actuate (audible click). | Motor and pump locked. Mechanical bind or defective motor. | Allow motor to cool and recheck. | Replace motor/pump if defective. |
| | Cylinder solenoids do not actuate but motor runs. | Defective time delay relay. | Unplug unit from wall receptacle and temporarily bypass time delay relay by disconnecting wire from #2 terminal and attaching it to #1 terminal. Check operation, if cylinders now actuate, relay is defective. | Replace time delay relay. |
| Motor and all electrical function properly. | Low on hyrauiic oil. | Check oil level. | Add oil if necessary. | |

| Problem | Symptom | Probable Cause | Check | Correction |
|---|---|--|--|---|
| When all up and down switches are depressed individually, the table will not function when base up, tilt up, back up or foot up switch is actuated. Base down, tilt down, back down and foot down functions properly. | Motor runs and cylinder solenoids actuate (audible click). | Defective pump. | Pressure should be apparent in power hose, Item B, Fig. 29, when any up footswitch pedal is depressed. | Replace motor/pump if no pressure is apparent. |
| | | Anticavitation solenoid valve solenoid burned out. | Pressure will be apparent in power hose, Item B, Fig. 29, when any up footswitch pedal is depressed. Check for slight magnetism at small cap, Point E, Fig. 34 on end of anticavitation solenoid valve when an up footswitch pedal is depressed. | Replace anticavitation solenoid valve if faulty. |
| | | "Up" flow control may be closed. | Loosen locknut, turn setscrew counter-clockwise, and recheck. | Set "up" time for 13 seconds. |
| | Motor does not run (up actuations only) but cylinder solenoids actuate (audible click). | Blue wire of footswitch cord broken or disconnected or blue wire within footswitch broken or disconnected. | Check continuity of blue wires. Check connectors. | Replace footswitch cord if faulty. Replace blue jumper wire in footswitch if faulty. |
| When all switches are depressed individually, table will not function when base down, tilt down, back down or foot down switch is depressed. Base up, tilt up, back up, and foot up function properly. | Motor runs and cylinder solenoids actuate (audible click). | Defective pump. | Pressure should be apparent in pump hose, Item B, Fig. 36, when any down footswitch pedal is depressed. | Replace motor/pump if no pressure is apparent. |
| | | Anticavitation solenoid valve. | Pressure will be apparent in pump hose, Item B, Fig. 36, and should be apparent in return hose, Item D, Fig. 36 when down footswitch pedal is depressed. | Replace anticavitation solenoid valve if no pressure is apparent in return hose. |
| | | "Down" flow control may be closed. | Loosen locknut, turn setscrew counter-clockwise, and recheck. | Set "down" time for 12 seconds. |
| | Motor does not run (down actuations only) but cylinder solenoids actuate (audible click). | Red wire of footswitch cord broken or disconnected or red wire within footswitch broken or disconnected. | Check continuity of red wires. Check connectors. | Replace footswitch cord if faulty. Replace red jumper wire in footswitch if faulty. |
| When all switches are depressed individually, base up and base down does not function. All other actions function. | Motor runs but base cylinder solenoid does not actuate (no audible click). | White wire of footswitch cord broken or disconnected or white wire within footswitch broken or disconnected. | Check continuity of white wire. Check connectors. | Replace footswitch cord if faulty. Replace white jumper wire in footswitch if faulty. |
| | | Cylinder solenoid burned out. | above checks O.K. | Replace base cylinder. |

| Problem | Symptom | Probable Cause | Check | Correction |
|--|--|---|---|---|
| Base up functions but not base down or and base down functions but not base up. All other actions function. | Motor does not run and no base solenoid actuation (no audible click). | Footswitch out of adjustment. | Depress footswitch pedal and listen for audible click of microswitch. | Adjust footswitch if no audible click. |
| | Motor may or may not run and cylinder solenoid may or may not actuate. | Defective micro switch in foot-switch control. | Check continuity of micro switch in on and off positions. See wiring diagram. | Replace micro switch if continuity does not conform to wiring diagram. |
| When all switches are depressed individually, tilt up and tilt down does not function. All other actions function. | Motor runs but tilt cylinder solenoid does not actuate (no audible click). | Orange wire of footswitch cord is broken or disconnected or orange wire within foot-switch broken or disconnected. | Check continuity of orange wire. Check connectors. | Replace footswitch cord if faulty. Replace orange jumper wire in footswitch if faulty. |
| | | Cylinder solenoid burned out. | If above checks O.K. | Replace tilt cylinder. |
| Tilt up functions but not tilt down or tilt down functions but not tilt up. All other actions function. | Motor does not run and no tilt solenoid actuation (no audible click). | Footswitch out of adjustment. | Depress footswitch pedal and listen for audible click of microswitch. | Adjust footswitch if no audible click. |
| | Motor may or may not run and cylinder solenoid may or may not actuate. | Defective micro switch in foot-switch control. | Check continuity of micro switch in on and off positions. See wiring diagram. | Replace micro switch if continuity does not conform to wiring diagram. |
| When all switches are depressed individually, back up and back down does not function. All other actions function. | Motor runs but back cylinder solenoid does not actuate (no audible click). | White/black wire of footswitch cord is broken or disconnected or white/black wire within footswitch broken or disconnected. | Check continuity of white/black wire. Check connectors. | Replace footswitch cord if faulty. Replace white/black jumper wire in footswitch if faulty. |
| | | Cylinder solenoid burned out. | If above checks O.K. | Replace back cylinder. |
| Back up functions but not back down or back down functions but not back up. All other actions function. | Motor does not run and no back solenoid actuation. (no audible click). | Footswitch out of adjustment. | Depress footswitch pedal and listen for audible click of microswitch. | Adjust footswitch if no audible click. |
| | Motor may or may not run and cylinder solenoid may or may not actuate. | Defective micro switch in foot-switch control. | Check continuity of micro switch in on and off positions. See wiring diagram. | Replace micro switch if continuity does not conform to wiring diagram. |
| When all switches are depressed individually, foot up and foot down does not function. All other actions function. | Motor runs but foot cylinder solenoid does not actuate (no audible click). | Red/black wire of footswitch cord is broken or disconnected or red/black wire within foot-switch broken or disconnected. | Check continuity of red/black wire. Check connectors. | Replace footswitch cord if faulty. Replace red/black jumper wire in foot-switch if faulty. |
| | | Cylinder solenoid burned out. | If above checks O.K. | Replace foot cylinder. |
| Foot up functions but not foot down or foot down functions but not foot up. All other actions function. | Motor does not run and no foot solenoid actuation. (no audible click). | Footswitch out of adjustment. | Depress footswitch pedal and listen for audible click of micro switch. | Adjust microswitch if no audible click. |
| | Motor may or may not run and cylinder solenoid may or may not actuate. | Defective micro switch in foot-switch control. | Check continuity of micro switch in on and off positions. See Wiring Diagram. | Replace micro switch if continuity does not conform to wiring diagram. |

| Problem | Symptom | Probable Cause | Check | Correction |
|---|--|---|--|---|
| Either base, tilt, back or foot cylinder will not hold position. May drift down slowly. | Motor and all electrical functions properly. | Faulty micro switch in foot-switch control. May be holding cylinder solenoid in energized position. | Check for current with test lamp at cylinder terminal with switch in off position. Check both up and down switches. See wiring diagram. | If there is current at cylinder terminal with switch in off position, replace micro switch. |
| | | Dirt particle in Foot cylinder solenoid valve or faulty cylinder solenoid. | Flush dirt particle to reservoir by running cylinder in and out about 10 times if this does not help, a replacement cylinder will be needed. | Replace cylinder. |
| Back may be lifted or tilt may drift up with weight on the back section. | Motor and all electrical functions properly. | Defective anticavitation solenoid valve. | Lift on back section, if it raises with hand pressure, anticavitation valve is defective. | Replace anticavitation solenoid valve. |
| Excessive sideways play of table base. | Excessive sideways play of table base. | Loose stabilizing chains. | Check chains for tightness. | Tighten chains. |
| Auto return will not activate. | Motor runs, table moves down only as long as green push button is activated. | Stopcircuit is broken. | Check "red" stop switch for sticking or damage. | Replace red stop switch. |
| | | | Check limit switch, Item A, Fig. 37, for damage. | Replace limit switch. |
| | Motor will not run, cylinder solenoid click, footswitch causes normal table operation. | no Auto return relay not being activated. | Broken "green" auto return switch. | Replace "green" auto return switch. |
| | | | Limit switch broken. | Replace limit switch. |
| Auto return will start but will not stop when table reaches lowest position. | Motor pump continues to run. | Limit switch failing. | Check adjustment of limit switch wrong. | Adjust limit switch. |
| | | | Damage to limit switch. | Replace limit switch. |
| Auto return will start but will not stop when red stop button is activated. | Motor runs, table moves completely down to its lowest position. | Auto return circuit is always activated. | Check "green" auto return switch for sticking or damage. | Replace "green" auto return switch. |

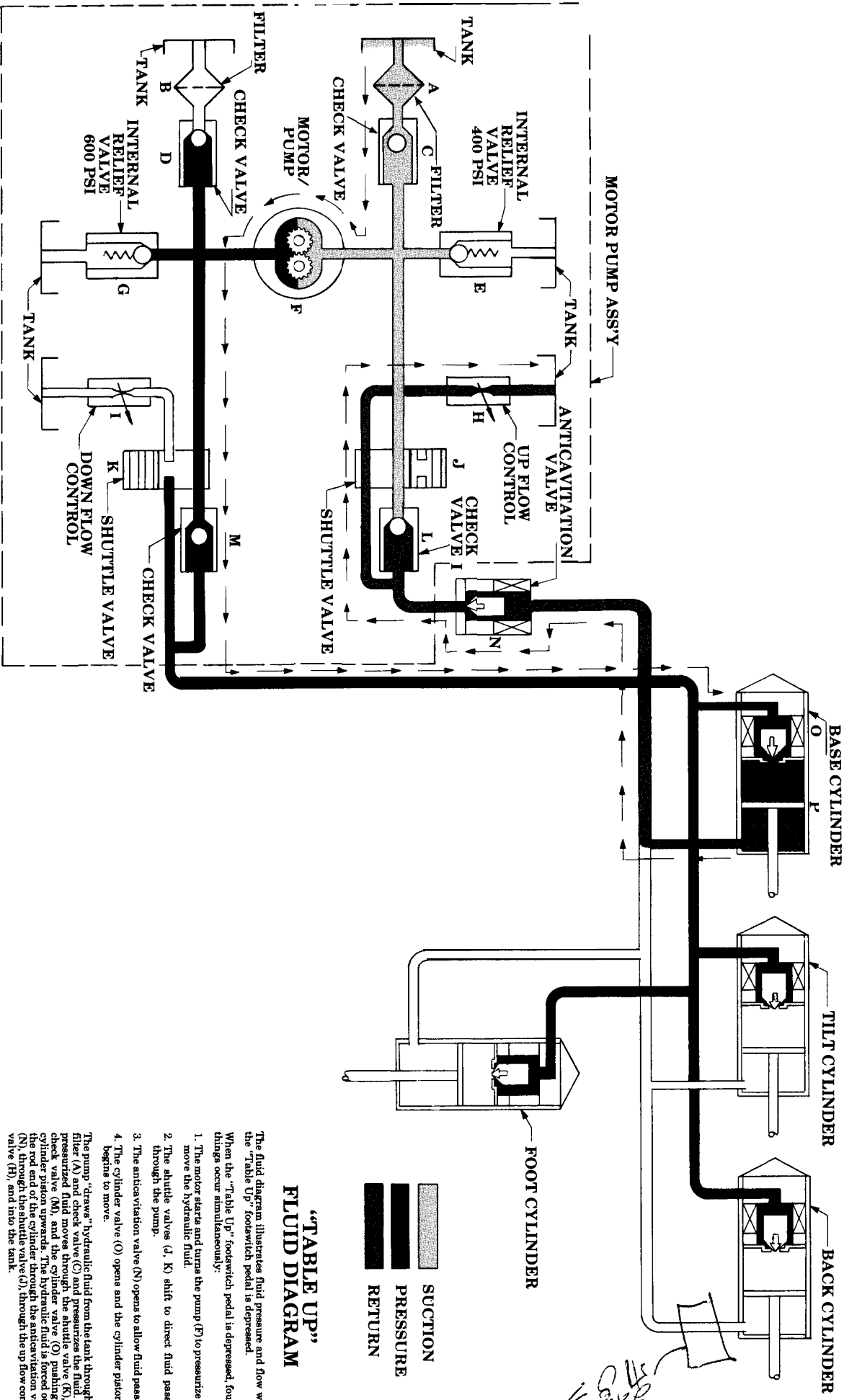

**"TABLE UP"
FLUID DIAGRAM**

- ▨ SUCTON
- ▬ PRESSURE
- - - RETURN

The fluid diagram illustrates fluid pressure and flow when the "Table Up" footswitch pedal is depressed, four things occur simultaneously:

1. The motor starts and turns the pump (F) to pressurize and move the hydraulic fluid.
2. The shuttle valves (J, K) shift to direct fluid passage through the pump.
3. The anticavitation valve (H) opens and the cylinder piston (P) begins to move.
4. The cylinder valve (O) opens and the cylinder piston (P) begins to move.

The pump "draws" hydraulic fluid from the tank through the filter (A) and check valve (C) and pressurizes the fluid. The pressurized fluid moves through the shuttle valve (K), the check valve (M), and the cylinder valve (O) pushing the cylinder piston upwards. The hydraulic fluid is forced out of the rod end of the cylinder through the anticavitation valve (N), through the shuttle valve (J), through the up flow control valve (H), and into the tank.

When the piston reaches the end of its stroke, the piston stops and the pressurized fluid returns to the tank through the internal relief valve (G).

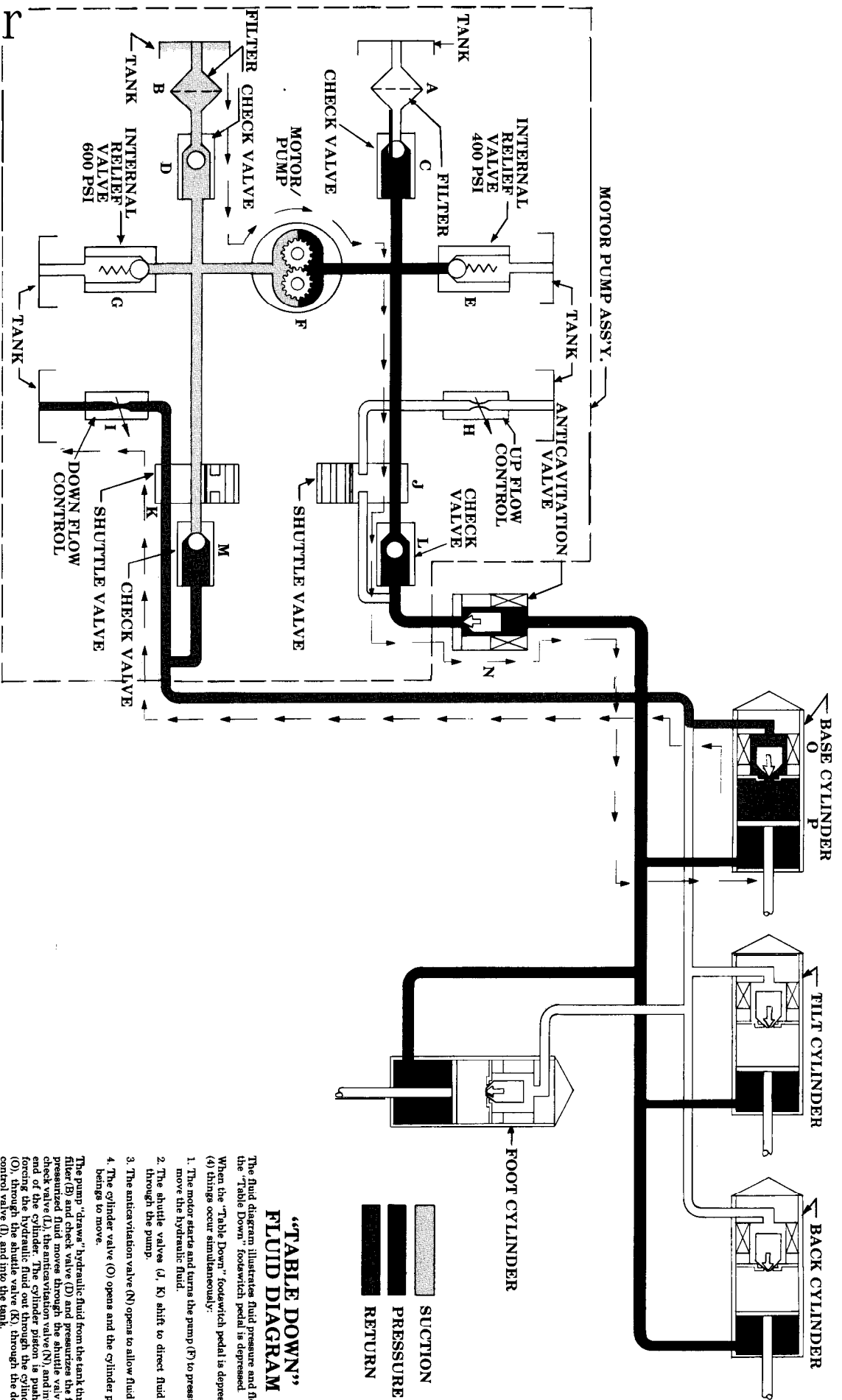

**“TABLE DOWN”
FLUID DIAGRAM**

Suction
 Pressure
 Return

1. The motor starts and turns the pump (F) to pressurize and move the hydraulic fluid.
 2. The shuttle valves (J, K) shift to direct fluid passage through the pump.
 3. The anticavitation valve (H) opens and the cylinder piston (P) begins to move.
 4. The cylinder valve (O) opens and the cylinder piston (P) draws hydraulic fluid from the tank through the filter (B) and check valve (D) and pressurizes the fluid. The pressurized fluid moves through the shuttle valve (J), the check valve (L), the anticavitation valve (H), and into the rod end of the cylinder. The cylinder piston is pushed down forcing the hydraulic fluid out through the cylinder valve (O), through the shuttle valve (K), through the down flow control valve (I), and into the tank.
- When the piston reaches the end of its stroke, the piston stops and the pressurized fluid returns to the tank through the internal relief valve (E).

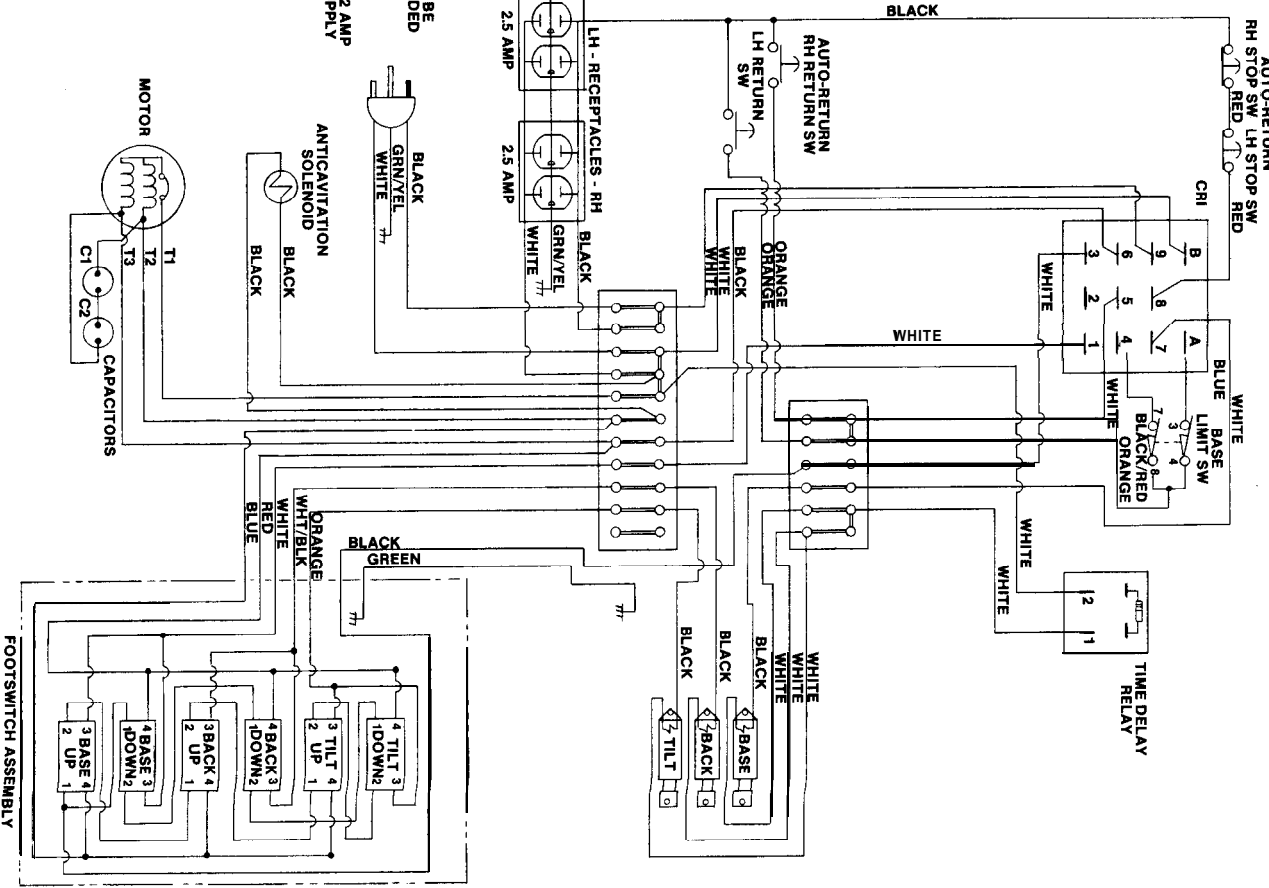
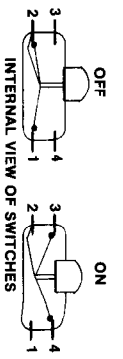

NOTE: IF AN UP SWITCH AND A DOWN SWITCH ARE ENERGIZED AT THE SAME TIME, THE CIRCUIT BECOMES INOPERATIVE.

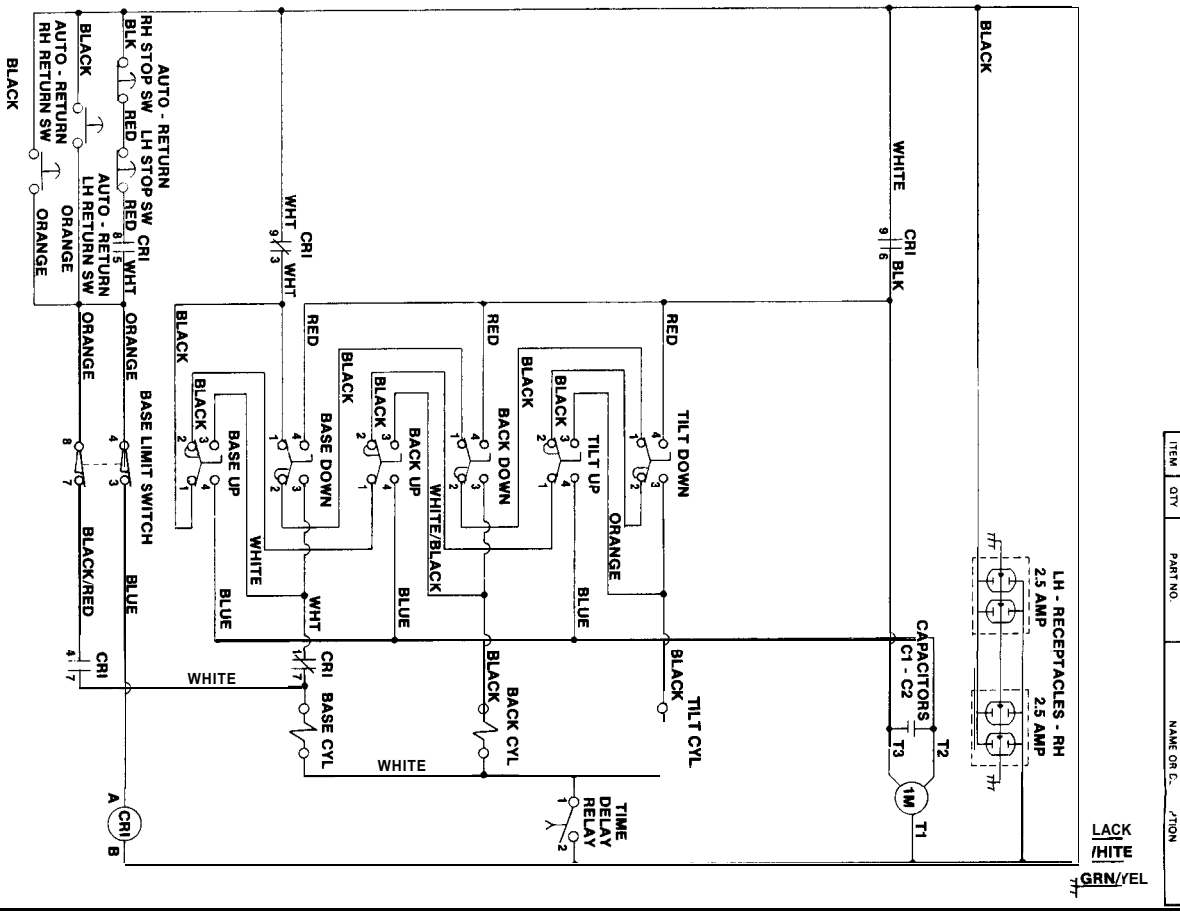

| | | | |
|---|-----|----------|------------------|
| ITEM | QTY | PART NO. | NAME OR LOCATION |
| <p>UNSPECIFIED GENERAL TOLERANCES FRACTIONAL ± SCALE DECIMAL XXX ± MAL CK BY DATE</p> <p>DATE 4/8/81</p> <p>WIRING DIAGRAM</p> <p>003-0277-00</p> | | | |
| <p>ECO NO. DATE CH BY CHANGE LTR</p> <p>THIS PRINT AND THE INFORMATION CONTAINED THEREIN ARE THE PROPERTY OF MIDMARK CORPORATION. IT IS LOANED TO THE INDICATED COMPANY IN CONFIDENCE AND IS NOT TO BE REPRODUCED, USED OR DISCLOSED TO OTHERS WITHOUT THE EXPRESS WRITTEN PERMISSION OF MIDMARK CORPORATION.</p> | | | |
| <p>MIDMARK</p> <p>MIDMARK CORPORATION, MEMBER OF QD 45885</p> | | | |

112 / 113 Service Parts

| Part No. | Description | Serial No. Range |
|------------------------|------------------------------|------------------------------|
| Upholstery | | |
| None Available | None Available | None Available |
| Panels | | |
| None Available | None Available | None Available |
| Hydraulics | | |
| 002-0001-00 | Base Cylinder | All |
| 002-0137-00 | Tilt Cylinder | All |
| 002-0003-00 | Back / Foot Cyl | All |
| 002-0117-00 | Pump Hose | All |
| 002-0118-00 | Return Hose (Pump to Base) | All |
| 002-0119-00 | Power Hose (Pump to Base) | All |
| 002-0120-00 | Return Hose (Base Cylinder) | All |
| 002-0121-00 | Power Hose (Base to Tilt) | All |
| 002-0122-00 | Return Hose (Base to Tilt) | All |
| 002-0123-00 | Power Hose (Tilt to Foot) | 112 Only |
| 002-0124-00 | Return Hose (Tilt to Foot) | 112 Only |
| 002-0125-00 | Power Hose (Tilt to Back) | All |
| 002-0126-00 | Return Hose (Tilt to Back) | All |
| 002-0178-00 | Return Hose (Tilt to Back) | All |
| 002-0038-00 | Anticavitation Valve | All |
| 014-0056-00 | Mineral Oil | All |
| 002-0127-00 | Motor Pump | Prior to AF1592 / All AG s/n |
| 002-0133-00 | Motor Pump | From AF1592 and up |
| 014-0168-00 | Shuttle Valve | All |
| 014-0169-00 | Shaft Seal - Motor Pump | All |
| 014-0125-00 | Needle Valve (back cylinder) | All |
| Hydraulics | | |
| 002-0041-00 | Time Delay Relay | All |
| 002-0040-00 | Power Cord | All |
| 002-0043-00 | Capacitor 64-77 MFP | |
| 002-0044-00 | Capacitor 124-149 MFP | |
| 002-0310-00 | Capacitor Retrofit Kit | |
| 002-0045-00 | Foot Control Switch | All |
| 002-0048-00 | Footswitch Cord | All |
| 015-0424-00 | Auto Return Switch-Green | |
| 015-0376-00 | Auto Return Switch - Red | |
| 015-0381-00 | Return Limit Switch | Prior to AF1167 / AG1046 |
| 015-0421-00 | Return Limit Switch | From AF1167 / AG1046 |
| 015-0374-00 | Auto Return Relay | |

COMMENTS

The Technical Publications Department of Midmark Corporation takes pride in its publications. We are sure that our manuals will fill all of your needs when you are performing scheduled maintenance, servicing, or repairs on a Midmark product.

However, if you find any errors or feel that there should be a change, addition, or deletion to a manual, please let us know!

Page(s) and Paragraph(s) Needing Changed:

Description of Error or Desired Change:

Please fax or mail a copy of this completed comment sheet to:

Midmark Corporation
ATTN: Technical Publications Department
60 Vista Drive
Versailles, Ohio 45380
Fax: (937) 526-5542

Midmark Corporation
60 Vista Drive
P.O. Box 286
Versailles, Ohio 45380-0286
937-526-3662
Fax 937-526-5542
midmark.com



Because we care.

Subject to change without notice.
Refer to www.Documark.com for latest revision.