

104 -001
thru
-015

Ritter[®]
by MIDMARK

Medical
Examination
Table

Serial Number Prefix:
E, F & V

Service and Parts Manual

**NO LONGER IN
PRODUCTION**
Some service parts may not
be available for this product!

104 -001
thru
-015

FOR USE BY MIDMARK
TRAINED TECHNICIANS ONLY

TABLE OF CONTENTS

Section/Paragraph	Page	Section/Paragraph	Page
IMPORTANT INSTRUCTIONS		SECTION VI PARTS LIST	
General Safety Instructions	ii	6.1 Introduction	6-1
Safety Alert Symbols	ii	6.2 Description of Columns	6-1
Warranty Instructions	ii	Base And Cabinet Assembly (With Side Doors)	6-2
SECTION I GENERAL INFORMATION		Base, Cabinet And Door Assembly (With Side Doors)	6-3
Not Applicable		Upper Wrap Assembly	6-4
SECTION II TESTING AND TROUBLESHOOTING		Seat And Headboard Upholstery Assembly	6-5.*
Not Applicable		Foot Rest Assembly	6-6
SECTION III SCHEDULED MAINTENANCE		Step Assembly	6-7
Not Applicable		Drawer Assembly	6-8.*
SECTION IV MAINTENANCE/SERVICE		Drawer Assembly (With Side Doors)	6-9
INSTRUCTIONS		Stirrup Assembly	6-10
Not Applicable		Wiring Diagram (Standard)	6-11
SECTION V SCHEMATICS AND DIAGRAMS		Wiring Diagram (Units w/ Heater)	6-12
Not Applicable		Pelvic Tilt Assembly (Optional)	6-13
		COMMENTS	7-1
		FAX ORDERING FORM	7-2

(*) Indicates that there has been a serial number break for the illustration and that there are additional point page(s) following the original page.

IMPORTANT INSTRUCTIONS

General Safety Instructions

Safety First: The primary concern of Midmark Corporation is that this table is maintained with the safety of the patient and staff in mind. To assure that services and repairs are completed safely and correctly, proceed as follows:

- (1) Read this entire manual before performing any services or repairs on this table.
- (2) Be sure you understand the instructions contained in this manual before attempting to service or repair this table.

Safety Alert Symbols

Throughout this manual are safety alert symbols that call attention to particular procedures. These items are used as follows:



DANGER

A DANGER is used for an imminently hazardous operating procedure, practice, or condition which, if not correctly followed, will result in loss of life or serious personal injury.



WARNING

A WARNING is used for a potentially hazardous operating procedure, practice, or condition which, if not correctly followed, could result in loss of life or serious personal injury.



CAUTION

A CAUTION is used for a potentially hazardous operating procedure, practice, or condition which, if not correctly followed, could result in minor or moderate injury. It may also be used to alert against unsafe practices.



EQUIPMENT ALERT

An EQUIPMENT ALERT is used for an imminently or potentially hazardous operating procedure, practice, or condition which, if not correctly followed, will or could result in serious, moderate, or minor damage to unit.

NOTE

A NOTE is used to amplify an operating procedure, practice or condition.

Warranty Instructions

Refer to the Midmark "Limited Warranty" printed in the Installation and Operation Manual for warranty information. Failure to follow the guidelines listed below will void the warranty and/or render the 102 Medical Examination Table unsafe for operation.

- In the event of a malfunction, do not attempt to operate the table until necessary repairs have been made.
- Do not attempt to disassemble table, replace malfunctioning or damaged components, or perform adjustments unless you are one of Midmark's authorized service technicians.
- Do not substitute parts of another manufacturer when replacing inoperative or damaged components. Use only Midmark replacement parts.

SECTION VI PARTSLIST

6.1 Introduction

The illustrated parts list provides information for identifying and ordering the parts necessary to maintain the unit in peak operating condition. Refer to paragraph 1.5 for parts ordering information.

The parts list also illustrates disassembly and assembly relationships of parts.

6.2 Description of Columns

The *Item* column of the parts list gives a component its own unique number. The same number is given to the component in the parts illustration. This allows a part number of a component to be found if the technician can visually spot the part on the illustration. The technician simply finds the component in question on the illustration and notes the item number of that component. Then, he finds that item number in the parts list. The row corresponding to the item number gives the technician the part number, a description of the component, and quantity of parts per subassembly. Also, if a part number is known, the location of that component can be determined by looking for the item number of the component on the illustration.

The *Part No.* column lists the MIDMARK part number for that component.

The *Description* column provides a physical description of the component.

The *Qty.* column lists the number of units of a particular component that is required for the subassembly. The letters "AR" denote "as required" when quantities of a particular component cannot be determined, such as: adhesive.

Bullets { • } in the *Part No.* column and the *Description* column show the indenture level of a component. If a component does not have a bullet, it is a main component of that illustration. If a component has a bullet, it is a subcomponent of the next component listed higher in the parts list than itself that does not have a bullet. Likewise, if a component has two bullets, it is a subcomponent of the next component listed higher in the parts list than itself that has only one bullet.

Base And Cabinet Assembly (With Side Drawers)

SECTION VI PARTS LIST

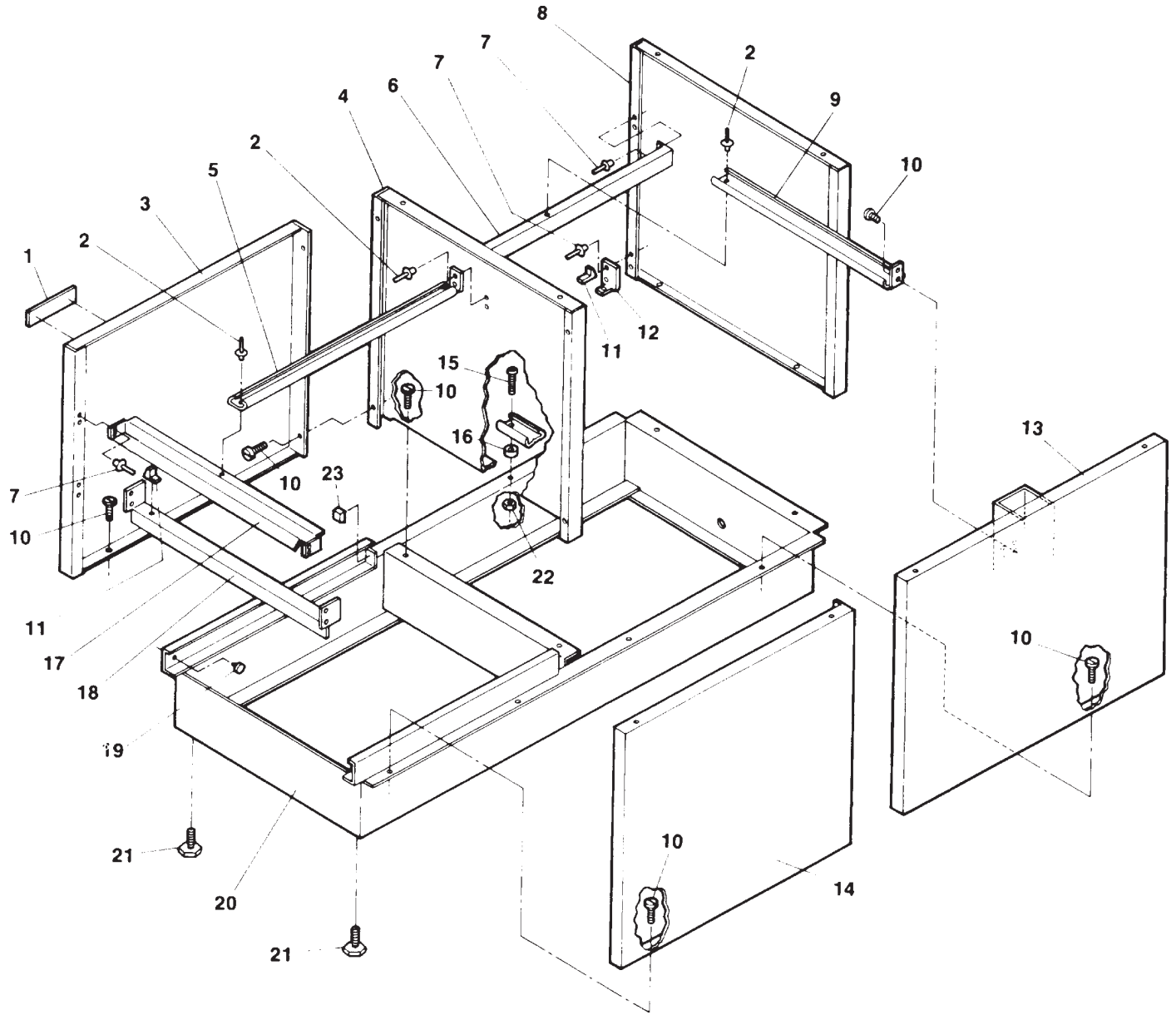

Item	Part No.	Description	Qty.	Item	Part No.	Description	Qty.
1	061-0215-02	104 Nameplate	1	12	050-0587-00	Bracket	1
2	042-0010-03	Pop Rivet	10	13	030-0293-00	Back Weldment	1
3	050-0183-01	L.H. Front Support	1	14	050-0183-00	R.H. Front Support	1
4	050-0606-02	Center Support	1	15	040-0008-10	Screw	1
5	016-0136-00	Slide Front (See Drawer Parts List)	2	16	052-0045-00	Spacer	1
6	050-0915-00	Mullion	2	17	050-0916-00	Mullion	1
7	042-0010-01	Pop Rivet	18	18	050-0824-00	Mullion	1
8	050-0187-00	End Panel	1	19	053-0001-00	Nylon Stem Bushing	2
9	N.L.A.	Slide Cabinet (See Drawer Parts List)	1	20	030-0192-00	Base Weldment	1
10	040-0010-00	Screw (On earlier models, pop rivets, item 2 were used in place of screws for mounting slides)	44	21	016-0001-00	Leveling Screw	4
11	053-0004-00	Glide	10	22	041-0008-02	Nut	2
				23	053-0014-00	Self Sticking Bumper	2

Always Specify Model & Serial Number

Base, Cabinet And Door Assembly (With Side Doors)

SECTION VI PARTS LIST

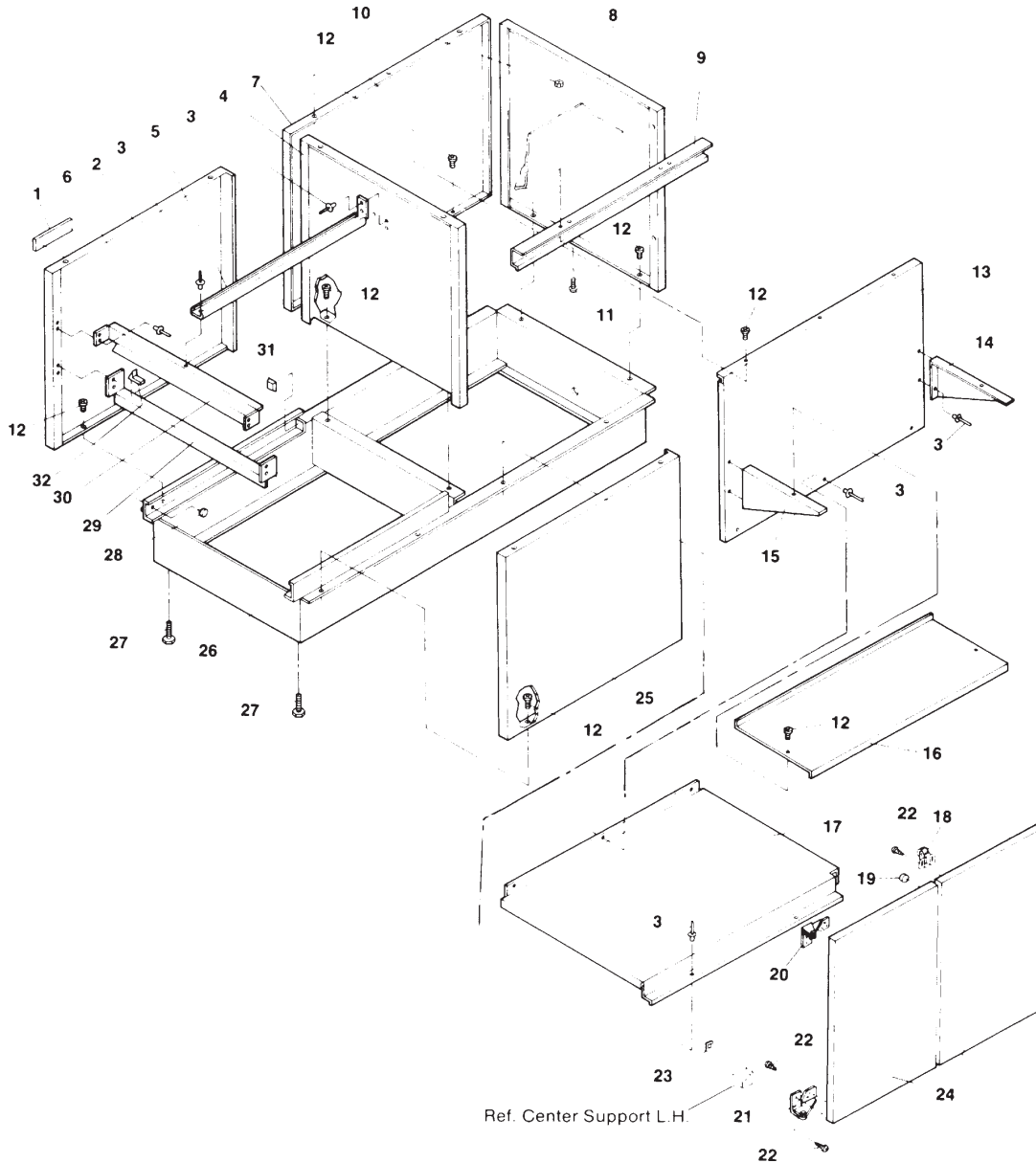

MA2704

Item	Part No.	Description	Qty.	Item	Part No.	Description	Qty.
1	061-0215-02	Name Plate	1	17	050-1124-01	L.H. Bottom Shelf	1
2	050-0183-01	L.H. Front Support	1	18	016-0004-00	Roller Catch	2
3	042-0010-03	Pop Rivet	13	19	053-0013-00	Self Sticking Bumper	8
4	050-0606-05	L.H. Center Support	1	20	016-0012-05	L.H. Hinge	2
5	016-0136-00	Front Slide	2	21	016-0012-04	R.H. Hinge	2
6	042-0010-01	Pop Rivet	8	22	040-0006-01	Screw	24
7	050-0185-00	Back	1	23	041-0007-00	Speed Nut	12
8	050-0187-05	L.H. End Panel	1	24	055-6100-01	Cabinet Door	2
9	050-1123-00	Mullion	1	25	050-0183-00	R.H. Front Support	1
10	041-0008-02	Nut	2	26	030-0192-00	Base Weldment	1
11	040-0008-18	Screw	2	27	016-0001-00	Leveling Screw	4
12	040-0010-00	Screw	43	28	053-0001-00	Nylon Stem Bushing	2
13	050-1125-00	Shelf Back	1	29	050-0824-00	Mullion	1
14	050-0167-00	R.H. Shelf Bracket	1	30	050-0916-00	Mullion	1
15	050-0167-01	L.H. Shelf Bracket	1	31	053-0014-00	Self Sticking Bumper	4
16	050-0166-02	Shelf	1	32	053-0004-00	Glide	4

Always Specify Model & Serial Number

Upper Wrap Assembly

SECTION VI PARTS LIST

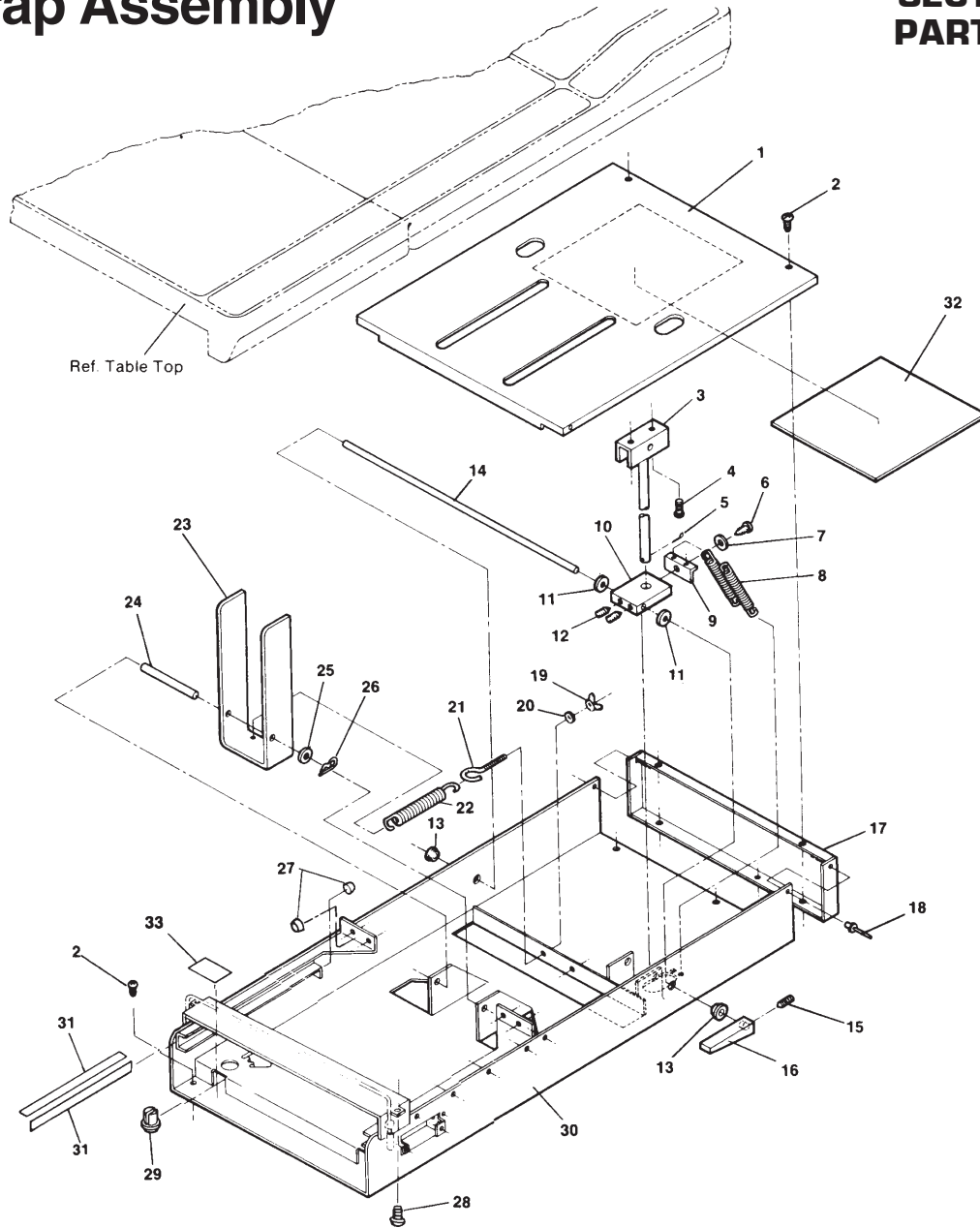

MA2694-01

Item	Part No.	Description	Qty.	Item	Part No.	Description	Qty.
1	029-0305-00	Top Cover Assembly (Includes Sound Damp, Item 32)	1	16	021-0001-01	Back Lock Lever	2
	050-0557-00	Top Cover (Sound Damp - Not Included)	1	17	050-0180-00	End Cap	1
2	040-0010-00	Screw	52	18	042-0010-03	Pop Rivet	2
3	029-0151-00	Back Support Rod Assembly	1	19	041-0250-05	Wing Nut	2
4	040-0010-01	Screw	2	20	045-0001-02	Flat Washer	2
5	042-0003-00	Cotter Pin	1	21	016-0008-00	Eye Bolt	2
6	040-0010-03	Screw	1	22	025-0003-00	Lift Spring	2
7	045-0001-04	Lockwasher	1	23	051-0132-00	Lift Lever	1
8	025-0008-00	Backlock Spring	2	24	057-004-00	Lift Support Rod	1
9	050-0101-00	Backlock Spring Retainer	1	25	045-0001-01	Flat Washer	4
10	051-0002-00	Backlock	1	26	042-0004-00	Hitch Pin	2
11	045-0001-01	Flat Washer	2	27	053-0014-00	Self Sticking Bumper	2
12	040-0250-00	Set Screw	2	28	061-0004-00	Stirrup Instruction Tag	1
13	053-0068-01	Snap Bushing	3	29	053-0082-00	Pivot Boss	2
14	057-0003-00	Back Lock Rod	1	30	030-0179-00	R.H. Upper Wrap	1
15	040-0250-05	Set Screw	2		030-0179-02	R.H. Upper Wrap (For Heater)	1
				31	053-0018-00	Nylon Tape (Listed In Inches)	46
				32	054-0067-00	Sound Damp	1

Always Specify Model & Serial Number

Seat and Headboard Upholstery Assembly

SECTION VI PARTS LIST

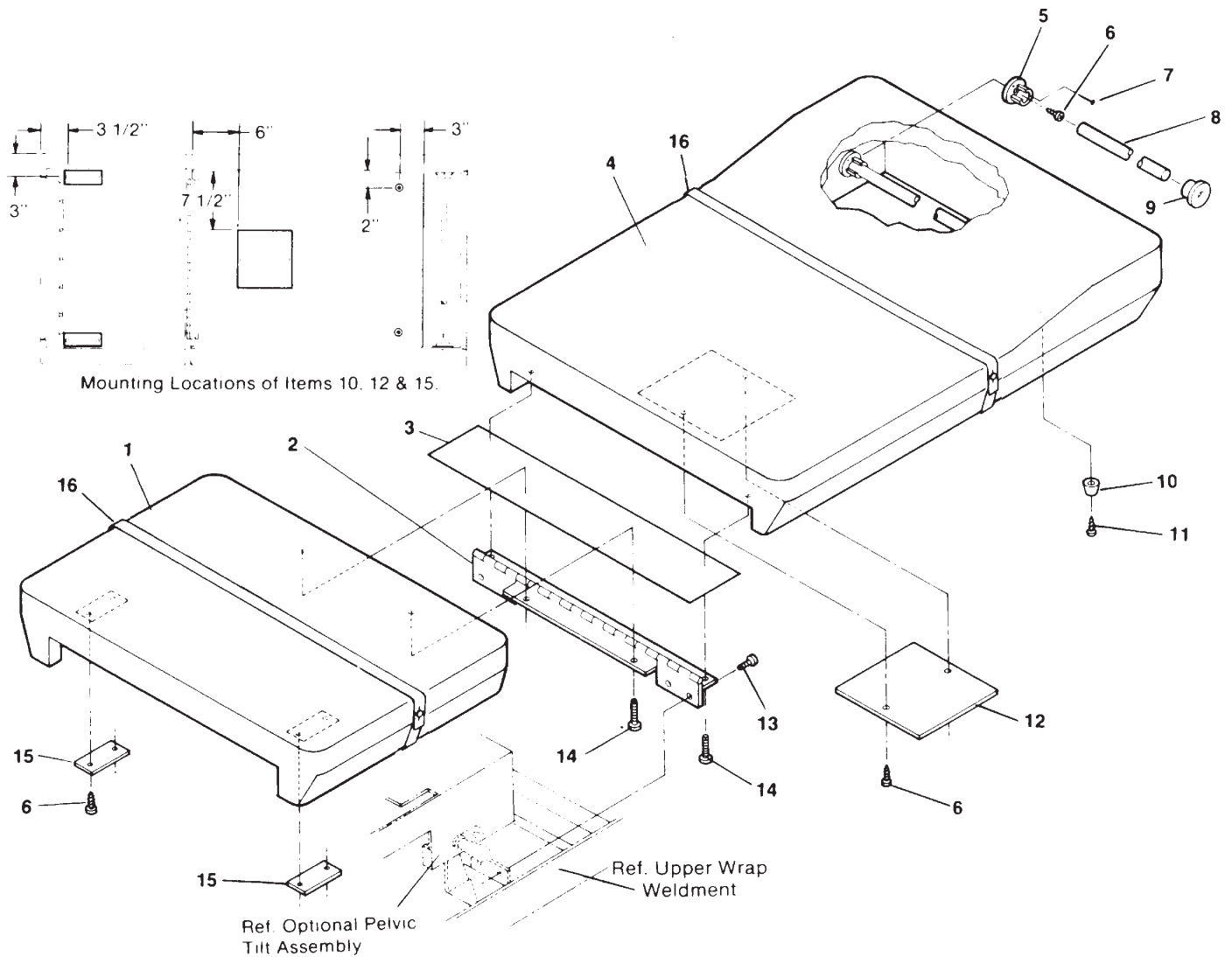

MA2706

Used On Units With Serial Numbers E1000 / F1000 Thru E15115 / F1822

Item	Part No.	Description	Qty.	Item	Part No.	Description	Qty.
1	002-0279-00	Upholstered Seat Without Pelvic Lift	1	8	055-0005-00	Wood Dowel	1
	002-0097-00	Upholstered Seatboard With Pelvic Lift	1	9	053-0043-01	R.H. Plastic Pole Socket	1
2	016-0009-01	Top Hinge	1	10	053-0024-00	Recess Bumper	2
3	056-0203-00	Vinyl Hinge Cover	1	11	040-0008-00	Screw	2
4	N.L.A.	Upholstered Headboard Assembly	1	12	050-0194-00	Plate	1
5	053-0043-02	L.H. Plastic Pole Socket	1	13	040-0010-04	Screw	4
6	040-0006-26	Screw	6	14	040-0010-01	Screw	7
7	042-0605-00	Wire Nail	1	15	050-0818-00	Scuff Plate	2
				16	002-0049-00	Paper Tear Strip Assembly	2

N.L.A. Denotes "No Longer Available"
Always Specify Model & Serial Number

Seat And Headboard Upholstery Assy.

SECTION VI PARTS LIST

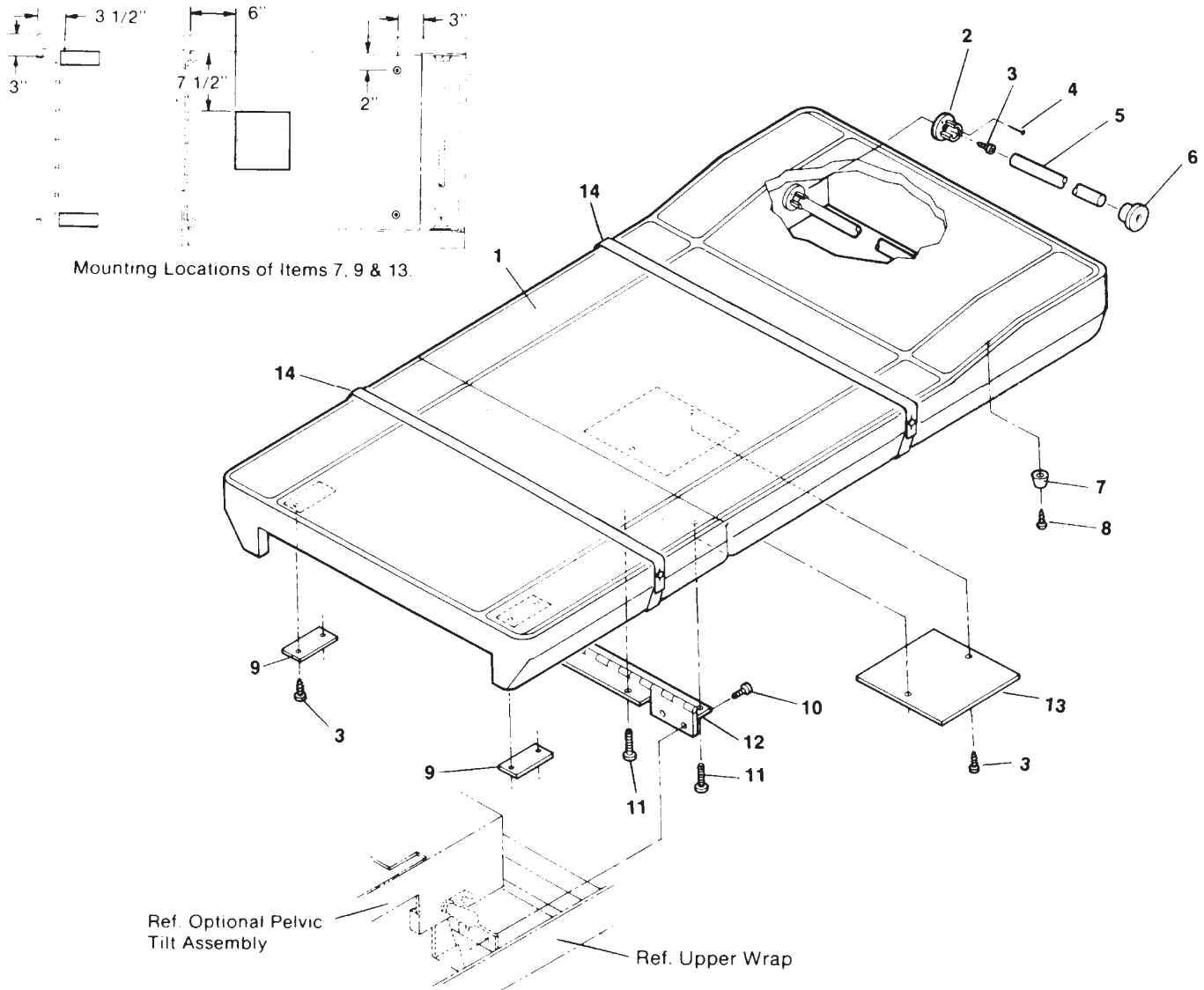

MA2707

Used On Units With Serial Numbers E15116 / F1823 Thru Present

Item	Part No.	Description	Qty.	Item	Part No.	Description	Qty.
1	002-0138-00	Upholstered Table Top (With Pelvic Lift)	1	7	053-0024-00	Recess Bumper	1
	002-0140-00	Upholstered Table Top (Without Pelvic Lift)	1	8	040-0008-00	Screw	2
2	053-0043-02	L.H. Plastic Pole Socket	1	9	050-0194-00	Scuff Plate	2
3	040-0006-26	Screw	6	10	040-0010-35	Screw	4
4	042-0605-00	Wire Nail	1	11	040-0010-01	Screw	7
5	055-0005-00	Wood Dowel	1	12	016-0009-01	Top Hinge	1
6	053-0043-01	R.H. Plastic Pole Socket	1	13	050-0194-00	Plate	1
				14	002-0049-00	Paper Tear Strip Assembly	2

Always Specify Model & Serial Number

Foot Rest Assembly

SECTION VI PARTS LIST

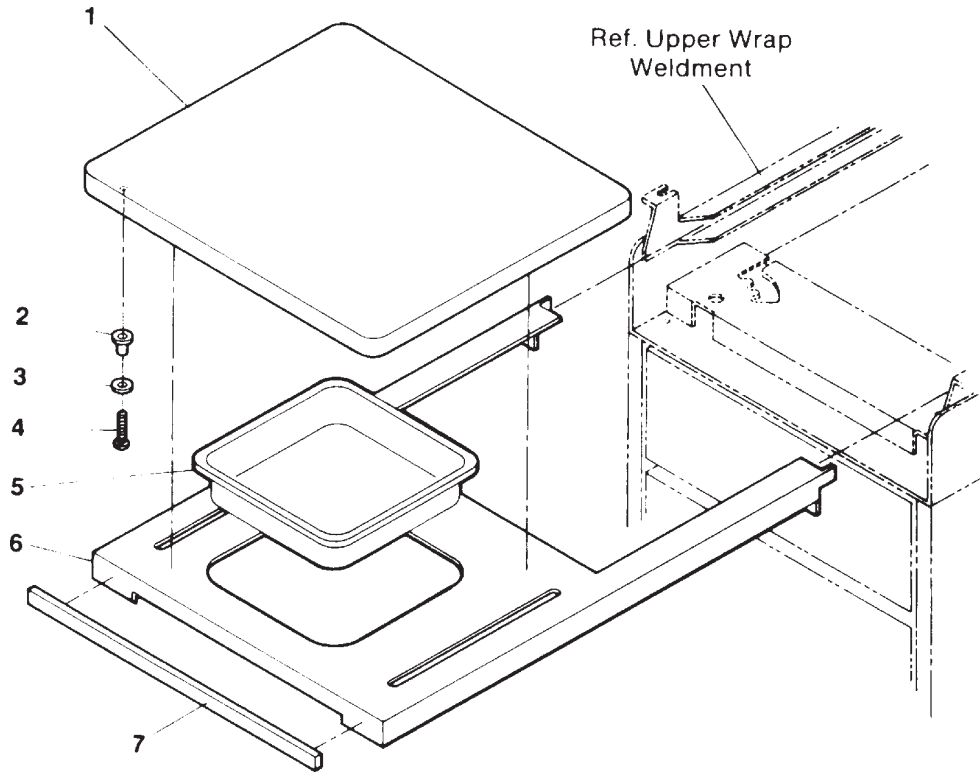

MA2708

Item	Part No.	Description	Qty.	Item	Part No.	Description	Qty.
1	002-0283-00	Upholstery Footrest Pad (Includes Item 1, 2, 3, and 4)	1	6	030-0024-01	Footrest (Used On Units With Serial Numbers 1000 Thru 26298)	1
2	053-0011-00	Nylon Bushing	4		030-0181-00	Footrest (Used On Units With Serial Numbers 26298 Thru E31541 / F3933)	1
3	053-0021-00	Rubber Washer	4		030-0360-00	Footrest (Used On Units With Serial Numbers E31542 / F3934 Thru Present)	1
4	040-0250-02	Screw	4	7	029-0159-00	Footrest Shelf Trim Assembly	1
5	053-0029-00	Treatment Pan (Used On Units With Serial Numbers E1000 / F1000 Thru E31541 / F3933)	1				
	053-0220-00	Treatment Pan (Used On Units With Serial Numbers E31542 / F3934 Thru Present)	1				

Always Specify Model & Serial Number

Step Assembly

SECTION VI PARTS LIST

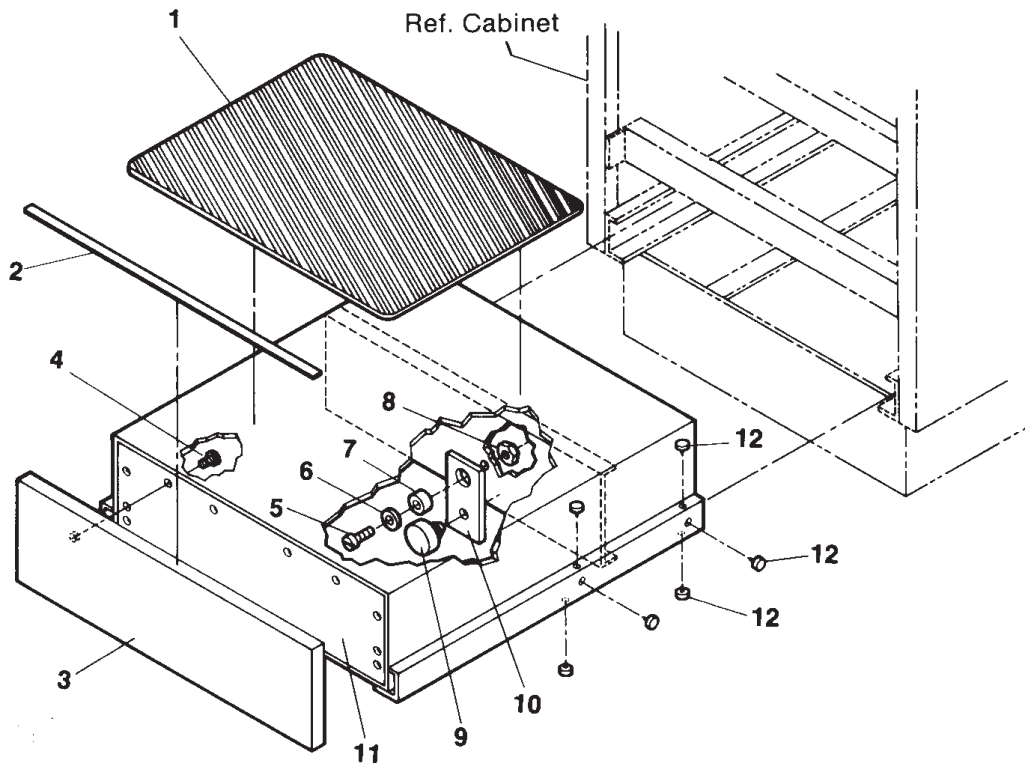

MA2709

Item	Part No.	Description	Qty.	Item	Part No.	Description	Qty.
	029-0162-00	Step Assembly - Complete	1	7	016-0138-09	Spacer	1
1	053-0048-00	Step Cover	1	8	041-0008-02	Nut	1
2	050-0379-00	Step Guard	1	9	053-0323-00	Button Bumper	1
3	055-1200-01	Step Front.....	1	10	051-0529-00	Step Stop Bar	1
4	040-0006-00	Screw	10	11	030-0587-00	Step Weldment	1
5	040-0008-06	Screw	1	12	053-0001-00	Nylon Stem Bumper	12
6	045-0001-39	Washer	1				

Always Specify Model & Serial Number

Drawer Assembly

SECTION VI PARTS LIST

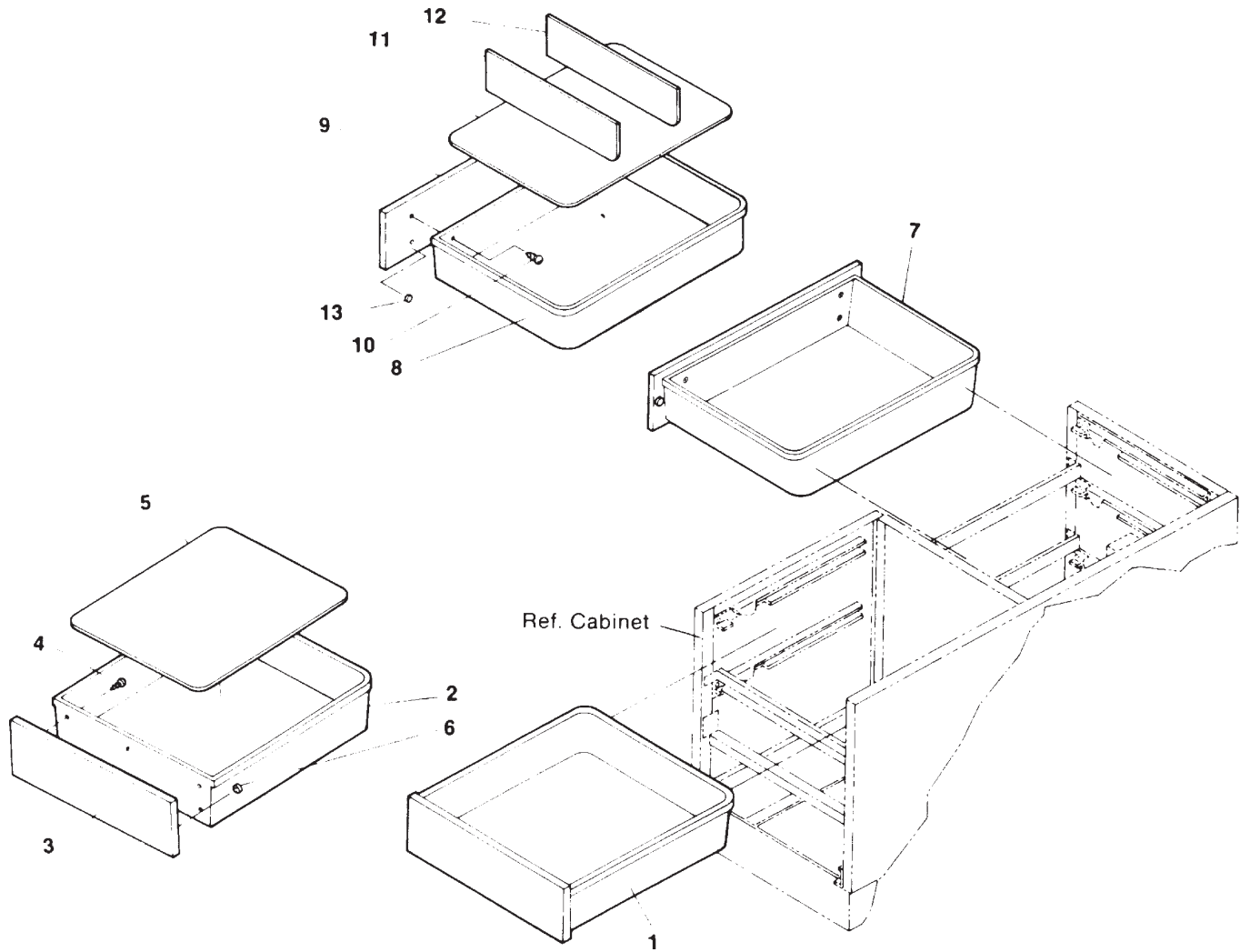

MA2710

Used On Units With Serial Numbers E1000 / F1000 Thru E15115 / F1822

Item	Part No.	Description	Qty.	Item	Part No.	Description	Qty.
1	029-0049-00	Front Drawer Assembly - Complete (Includes Items 2, 3, 4, and 6)	1	7	029-0023-00	Side Drawer Assembly - Complete (Includes Items 8, 9, 10, and 13)	1
2	• 053-0030-00	• Plastic Drawer	1	8	• 053-0032-00	• Plastic Drawer	1
3	• 055-1200-02	• Drawer Front	1	9	• 055-0500-01	• Drawer Front	1
4	• 040-0006-00	• Screw	5	10	• 040-0006-00	• Screw	4
5	• 060-0002-02	• Drawer Liner	1	11	• 060-0002-00	• Drawer Liner	1
6	• 053-0013-00	• Self-Sticking Bumper	2	12	• 053-0012-00	• Drawer Divider	3
				13	• 053-0013-00	• Self-Sticking Bumper	2

Always Specify Model & Serial Number

NOTE: Above quantities are for a one drawer unit.

Drawer Assembly

SECTION VI PARTS LIST

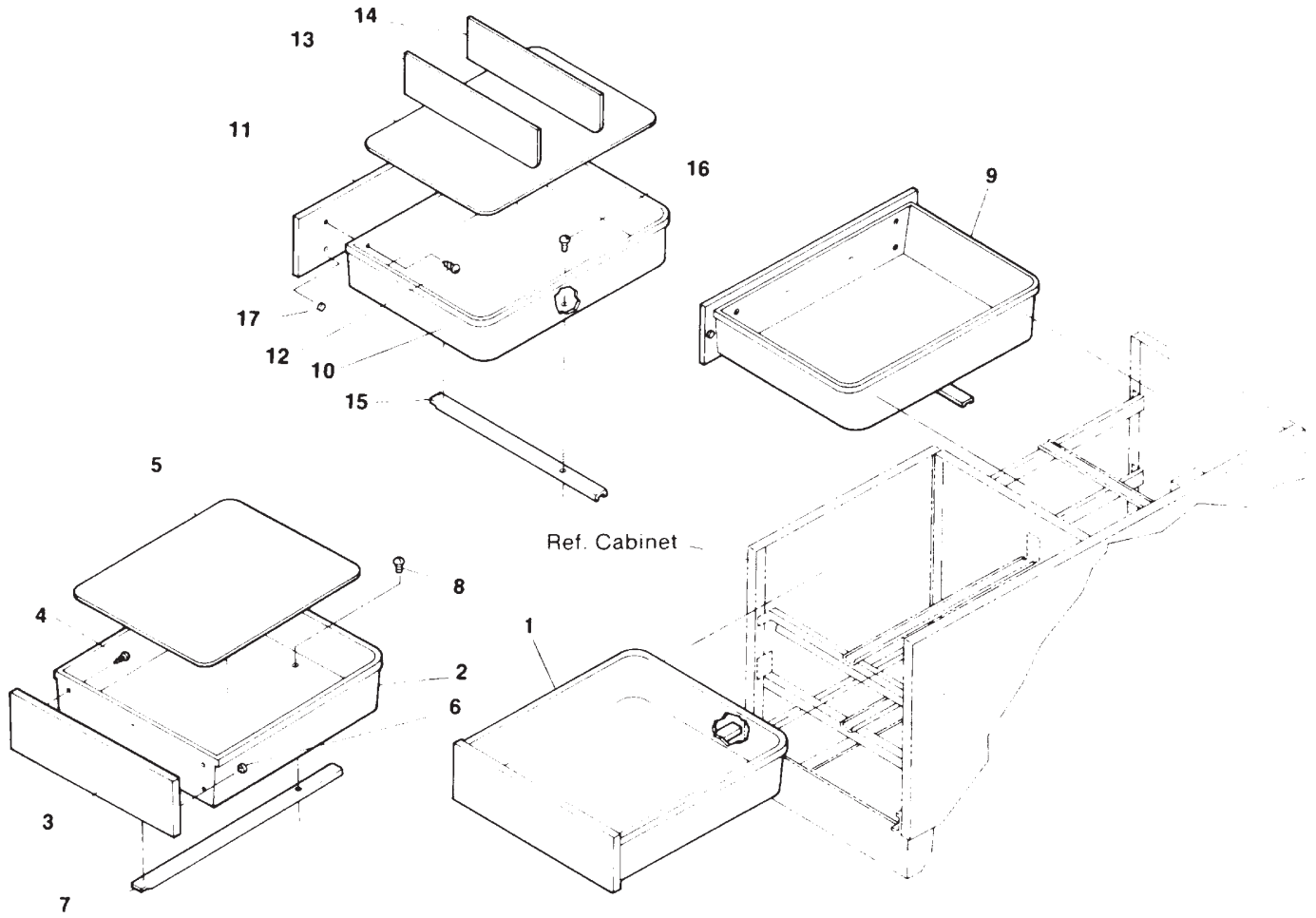

MA2711

Used On Units With Serial Numbers E15116 / F1823 Thru Present

Item	Part No.	Description	Qty.	Item	Part No.	Description	Qty.
1	029-0313-00	Front Drawer Assembly - Complete (Includes Items 2, 3, 4, 6, 7, and 8)	1	9	N.L.A.	Side Drawer Assembly - Complete (Includes Items 10, 11, 12, 15, 16, and 17)	1
2	• 053-0125-00	• Plastic Drawer	1	10	• 053-0124-00	• Plastic Drawer	1
3	• 055-1200-03	• Drawer Front	1	11	• 055-4700-00	• Drawer Front	3
4	• 040-0006-00	• Screw	6	12	• 040-0008-26	• Screw	6
5	• 060-0002-02	• Drawer Liner	1	13	• 060-0002-00	• Drawer Liner	1
6	• 053-0013-00	• Self-Sticking Bumper	2	14	• 053-0012-00	• Drawer Divider	1
7	• 016-0136-00	• Slide (Complete Inner & Outer)	1	15	• N.L.A.	• Slide (Complete Inner & Outer)	1
8	• 040-0008-26	• Screw	1	16	• 040-0008-26	• Screw	1
				17	• 053-0013-00	• Self-Sticking Bumper	2

Always Specify Model & Serial Number

NOTE: Above quantities are for a one drawer unit.

Drawer Assembly (With Side Doors)

SECTION VI PARTS LIST

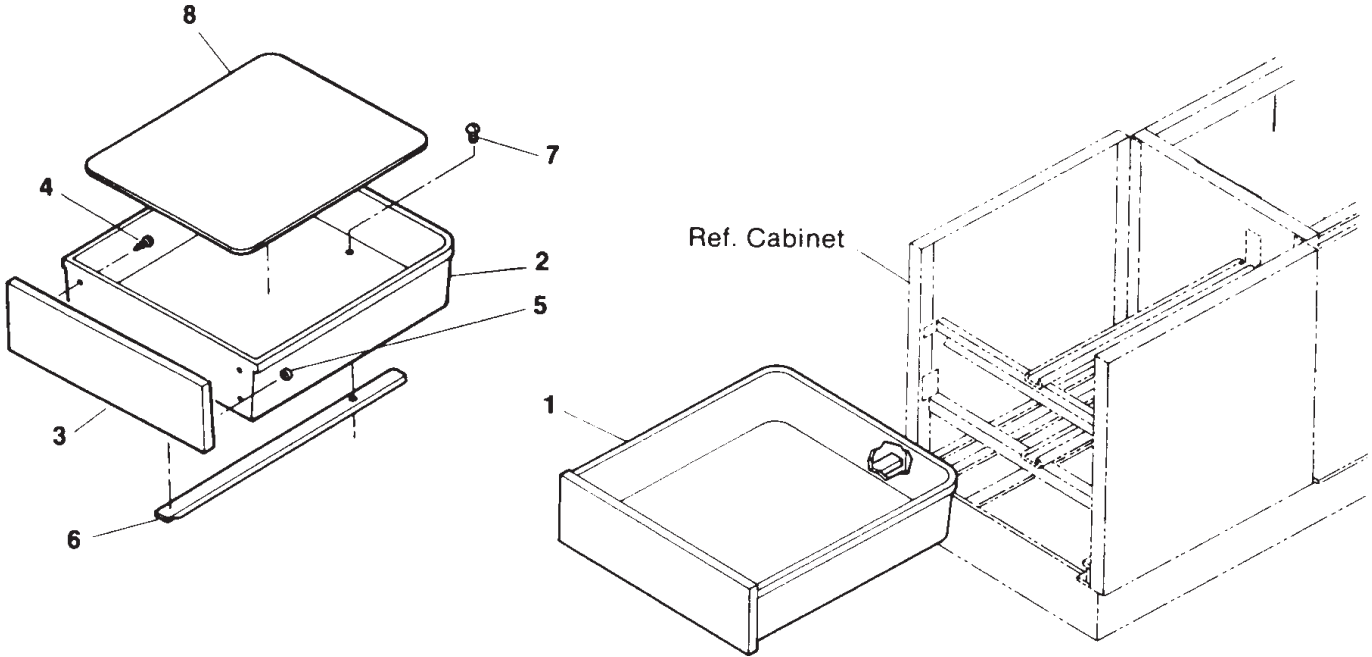

MA2712

Item	Part No.	Description	Qty.	Item	Part No.	Description	Qty.
1	029-0313-00	Drawer Assembly - Complete (Includes Items 2, 3, 4, 5, 6, and 7)	1	5	• 053-0013-00	• Self-Sticking Bumper	2
2	• 053-0125-00	• Plastic Drawer	1	6	• 016-0136-00	• Slide (Complete Inner & Outer)	1
3	• 055-1200-03	• Drawer Front	1	7	• 040-0008-26	• Screw	1
4	• 040-0006-00	• Screw	6	8	• 060-0002-02	• Drawer Liner	1

Always Specify Model & Serial Number

Stirrup Assembly

SECTION VI PARTS LIST

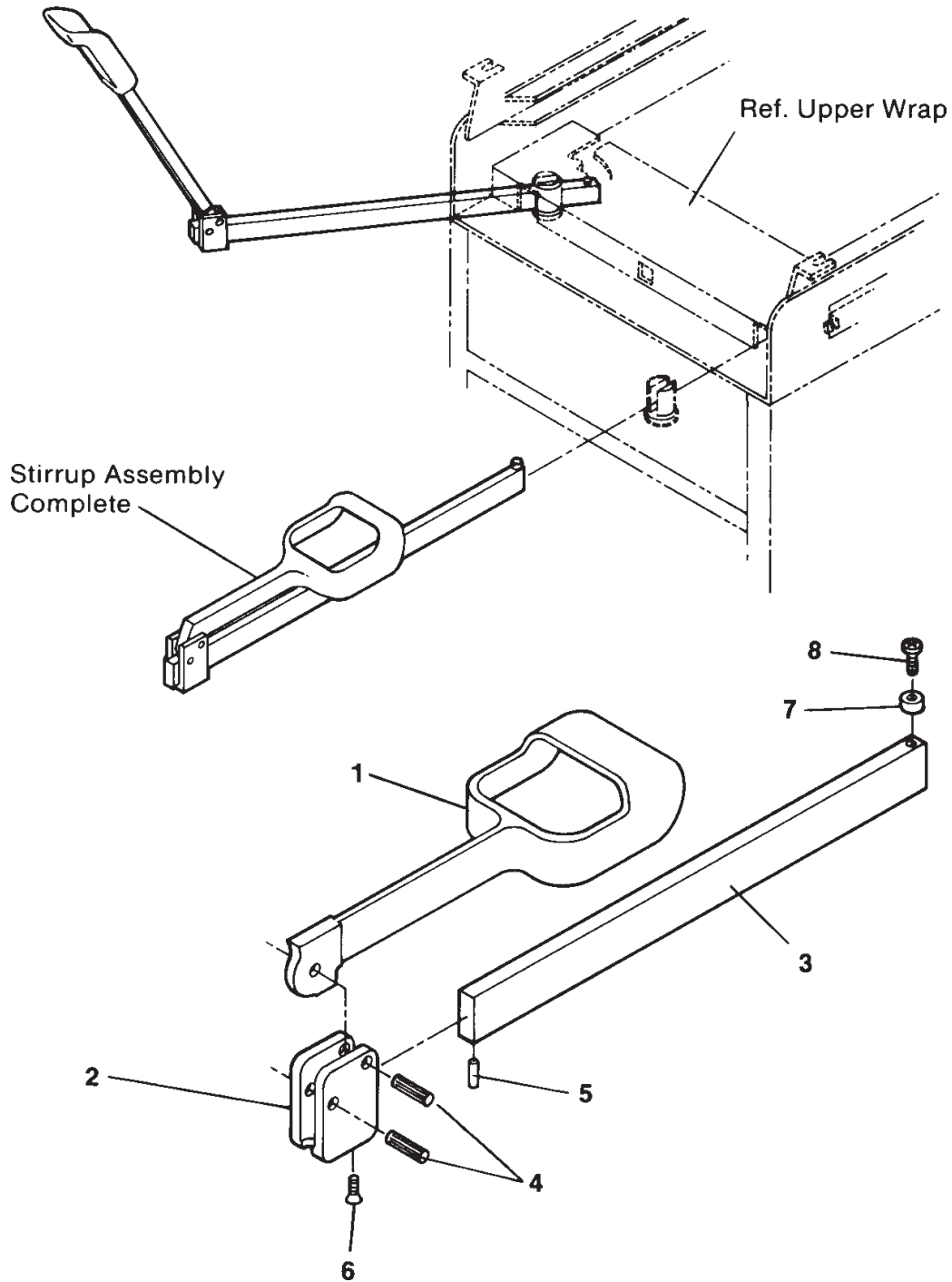

MA2652

Item	Part No.	Description	Qty.	Item	Part No.	Description	Qty.
	029-0152-00	Stirrup Assembly - Complete (Includes Items 1 thru 8)	1	4	042-0001-00	Roll Pin	2
1	020-0001-01	Vinyl Coated Stirrup	1	5	042-0001-02	Roll Pin	1
2	020-0012-00	Pivot Block	1	6	040-0250-15	Set Screw	1
3	051-0133-00	Horizontal Bar	1	7	053-0081-00	Nylon Bushing	1
				8	040-0250-01	Screw	1

Always Specify Model & Serial Number

Wiring Diagram (Standard)

SECTION VI PARTS LIST

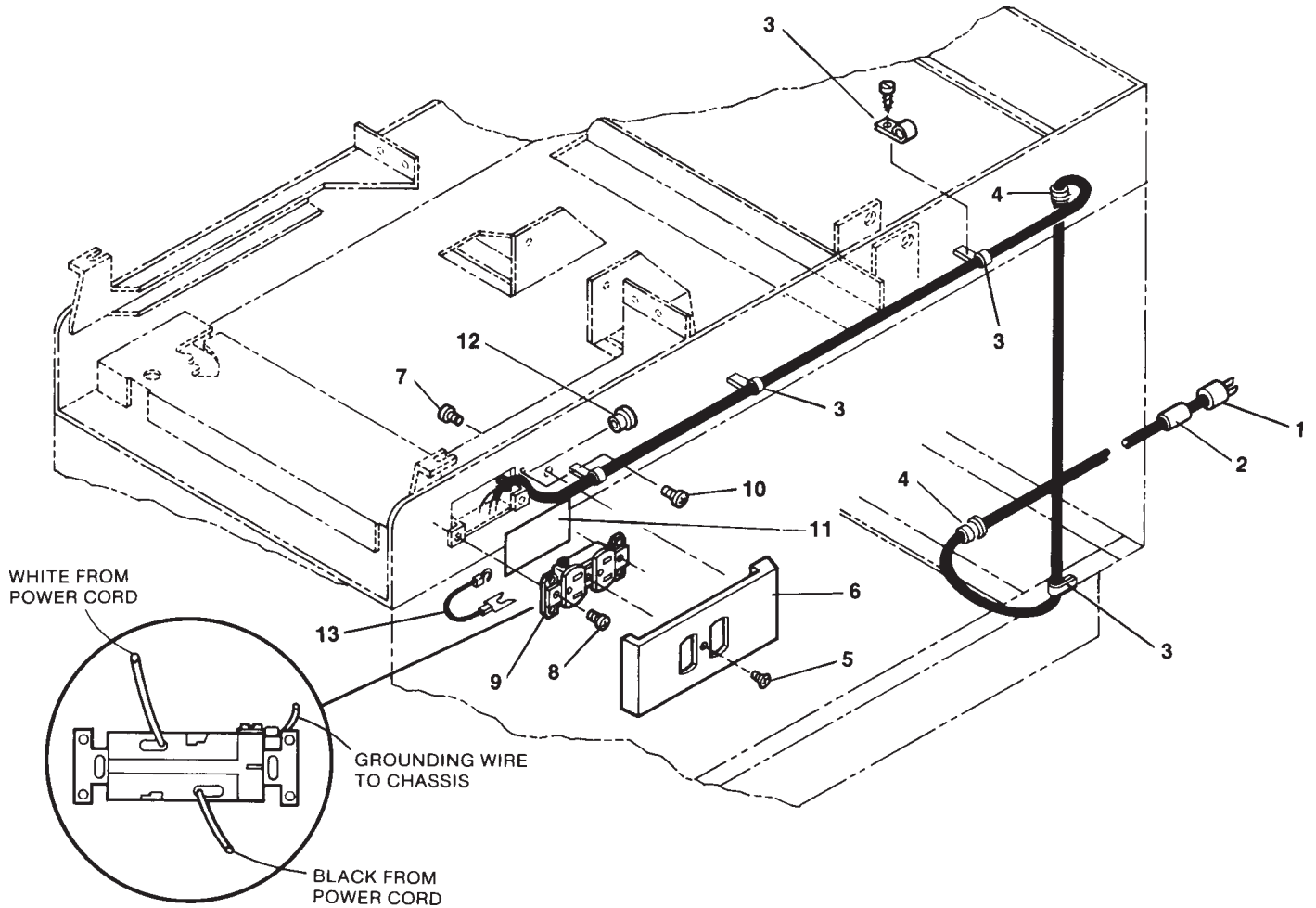

MA2653

Item	Part No.	Description	Qty.	Item	Part No.	Description	Qty.
1	015-0066-03	Cord Assembly	1	7	040-0010-04	Screw	1
2	061-0034-00	Cord Tag	1	8	040-0006-13	Screw	2
3	015-0007-02	Wire Clamp	4	9	015-0083-00	Duplex Receptacle	1
4	015-0002-01	Strain Relief Bushing	2	10	040-0010-47	Screw	2
5	040-0006-23	Screw	1	11	053-0092-00	Fishpaper Insulator	1
6	053-0134-00	Receptacle Cover	1	12	053-0068-07	Snap Bushing	1
				13	015-0141-00	Jumper Wire (To Chassis)	1

Always Specify Model & Serial Number

Wiring Diagram (Units w/ Heater)

SECTION VI PARTS LIST

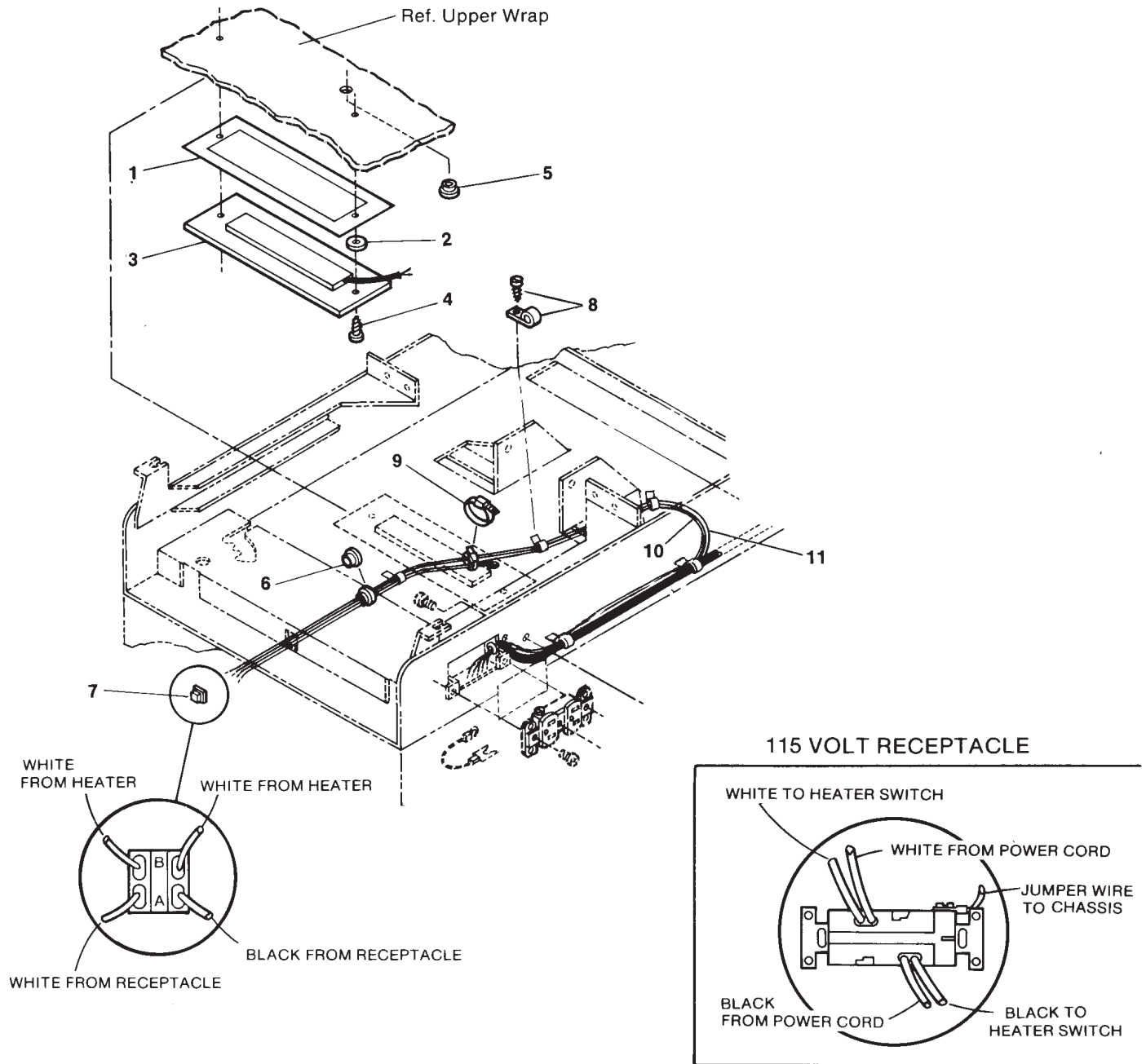

MA2654

Item	Part No.	Description	Qty.	Item	Part No.	Description	Qty.
1	053-0137-01	Heat Shield	1	7	015-0258-00	Heater Switch	1
2	016-0117-00	Roller	2	8	015-0007-03	Wire Clamp	3
3	029-0056-00	Heater Plate Assembly	1	9	015-0013-00	Cable Tie	3
4	040-0010-07	Screw	2	10	015-0064-03	Jumper Wire	1
5	053-0068-01	Snap Bushing	3	11	015-0064-02	Jumper Wire	1
6	053-0068-00	Snap Bushing	1				

Always Specify Model & Serial Number

Pelvic Tilt Assembly (Optional)

SECTION VI PARTS LIST

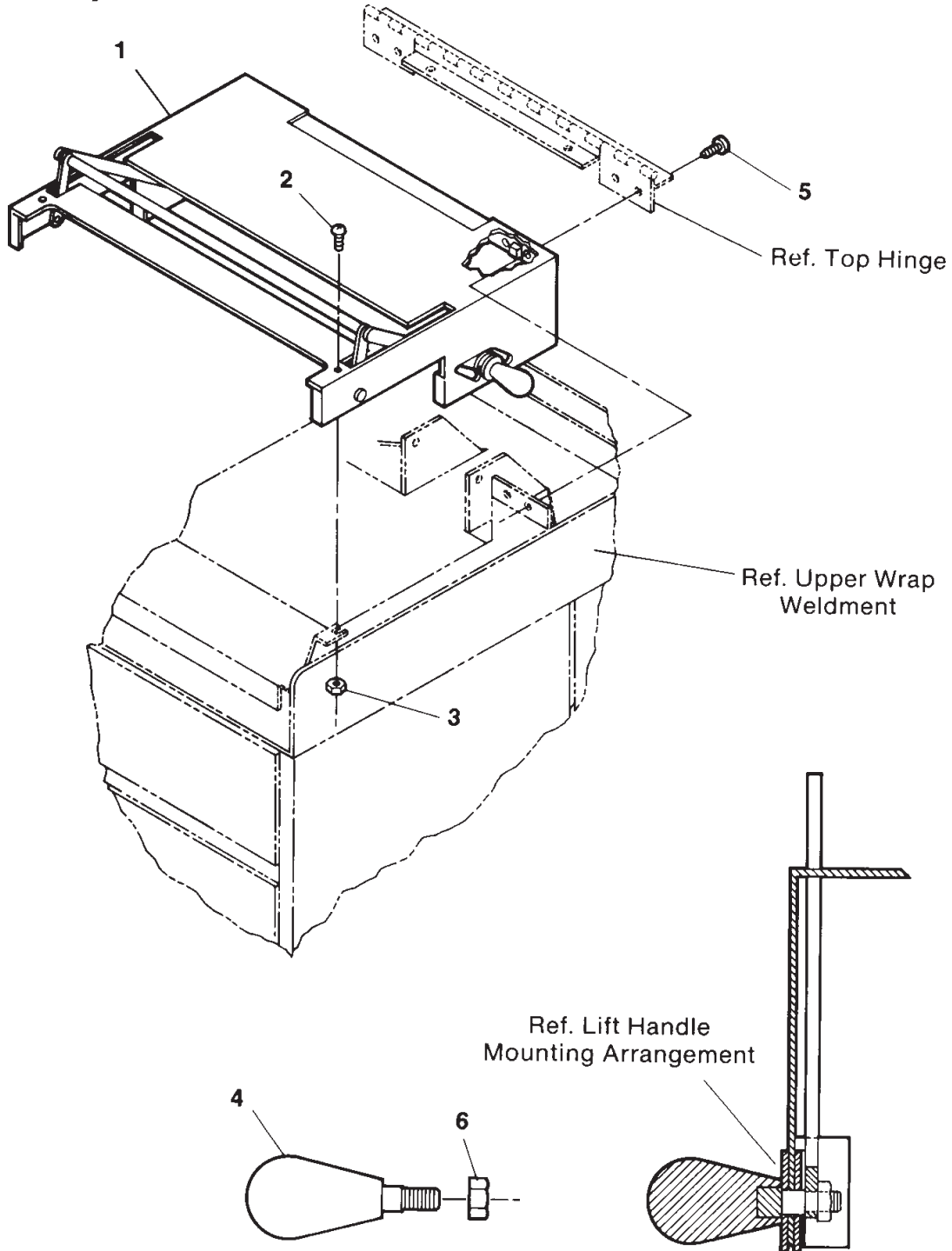

MA2655

Item	Part No.	Description	Qty.	Item	Part No.	Description	Qty.
1	029-0319-00	Pelvic Tilt Assembly - Complete (Includes Items 2, 3, 4, and 5)	1	4	•016-0184-00	• Lift Handle	2
2	•040-0010-23	• Screw	2	5	•040-0010-35	• Screw	4
3	•041-0010-02	• Nut	2	6	•041-0312-06	• Jam Nut	2

Always Specify Model & Serial Number

**SECTION VI
PARTS LIST**

COMMENTS

The Technical Publications Department of Midmark Corporation takes pride in its publications. We are sure that our manuals will fill all of your needs when you are performing scheduled maintenance, servicing, or repairs on a Midmark product.

However, if you find any errors or feel that there should be a change, addition, or deletion to a manual, please let us know!

Page(s) and Paragraph(s) Needing Changed:

Description of Error or Desired Change:

Please fax or mail a copy of this completed comment sheet to:

Midmark Corporation
ATTN: Technical Publications Department
60 Vista Drive
Versailles, Ohio 45380
Fax: (937) 526-5542

FAX ORDERING FORM

(SERVICE PARTS ONLY)

NOTES:

- ALL **BLOCKED** AREAS MUST BE COMPLETED.
- USE FOR NON-WARRANTY FAX ORDERS ONLY. WARRANTY ORDERS MUST BE TELEPHONED IN (1-800-MIDMARK).

ATTENTION: SERVICE DEPARTMENT FAX#: 877-249-1793				
ACCT #: _____		P.O. #: _____		DATE: _____
NAME: _____		SHIP TO: _____		
ADDRESS: _____		_____		
CITY, ST.: _____		_____		
CONTACT: _____		_____		
PHONE: _____		_____		
<input type="checkbox"/> NON-EMERGENCY ORDER - TO SHIP WITHIN 72 HOURS IF PART(S) IN STOCK.		METHOD OF SHIPMENT <u>OTHER</u> _____		
<input type="checkbox"/> EMERGENCY ORDER - TO SHIP WITHIN 24 HOURS IF PART(S) IN STOCK (IF ORDER IS RECEIVED BEFORE 1:00 P.M. E.S.T).		UPS FED EX		
SEND NOTIFICATION IF PARTS ARE NOT AVAILABLE TO SHIP WITHIN 24 HOURS VIA E-MAIL OR FAX TO: _____		<input type="checkbox"/> NEXT DAY A.M. <input type="checkbox"/> NEXT DAY A.M.		
		<input type="checkbox"/> NEXT DAY P.M. <input type="checkbox"/> NEXT DAY P.M.		
		<input type="checkbox"/> 2ND DAY <input type="checkbox"/> 2ND DAY		
		<input type="checkbox"/> GROUND <input type="checkbox"/> ECONOMY		
QTY.	PART #	DESCRIPTION (SPECIFY COLOR OF ITEM IF APPLICABLE)	COLOR CODE	PRICE/PER
			TOTAL COST: \$	

Midmark Corporation
60 Vista Drive
P.O. Box 286
Versailles, Ohio 45380-0286
937-526-3662
Fax 937-526-5542
midmark.com



Because we care.

Subject to change without notice.
Refer to www.Documark.com for latest revision.