

NOTE:
 * ALL BOLTS/FASTENERS NECESSARY TO ANCHOR LADDER BY OTHERS
 * PIPE HANDRAIL TO BE FIELD ASSEMBLED

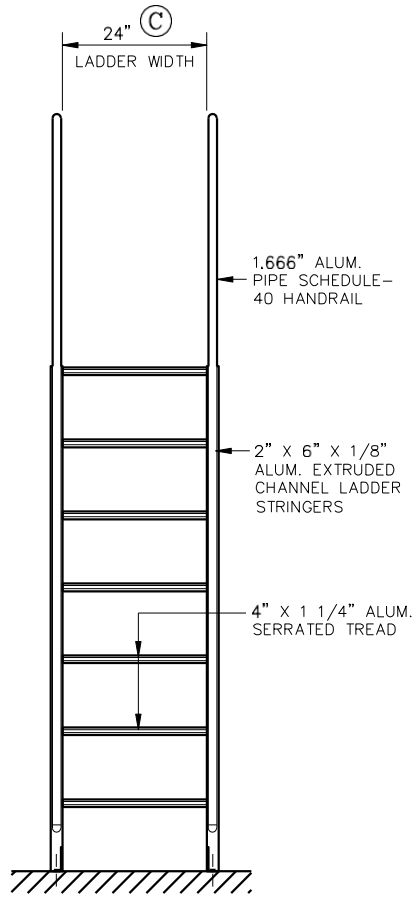

FRONT ELEVATION
N.T.S.

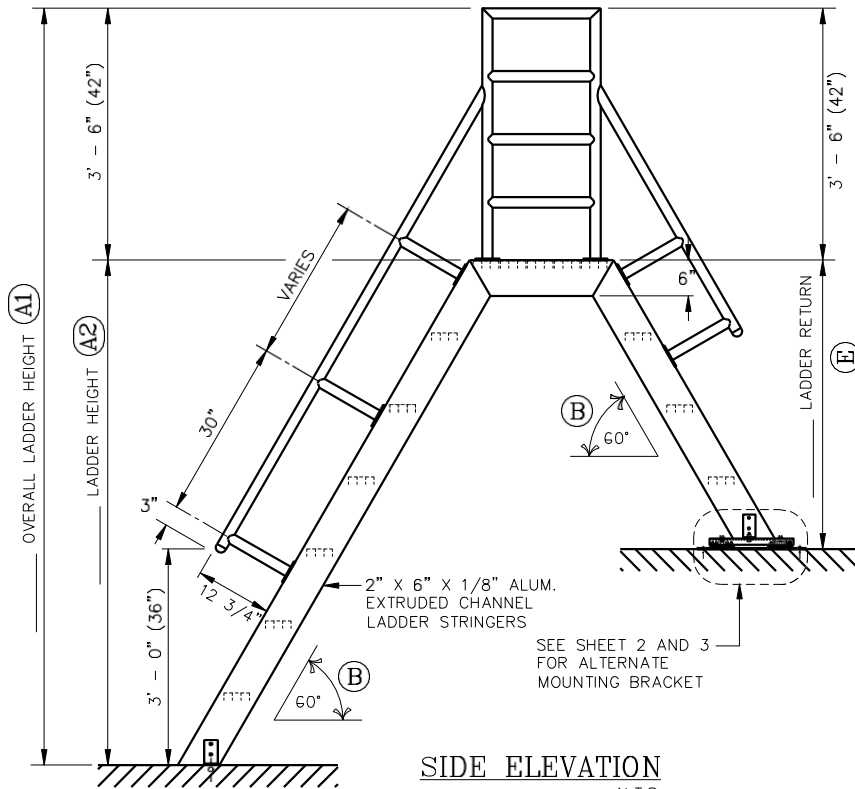

SIDE ELEVATION
N.T.S.

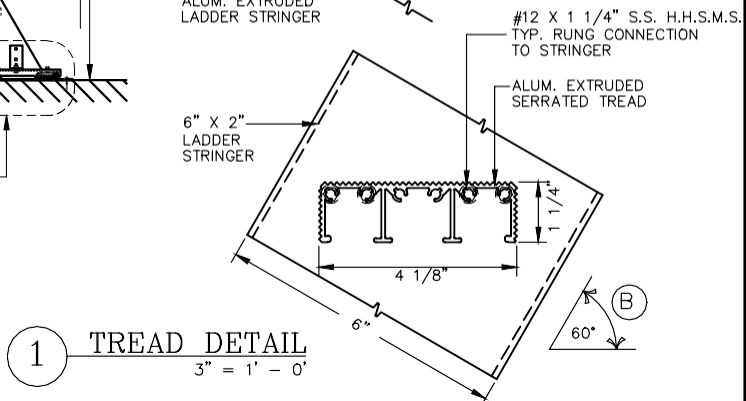
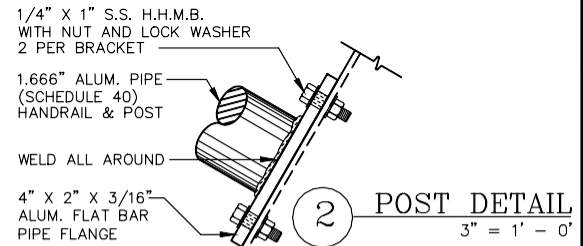
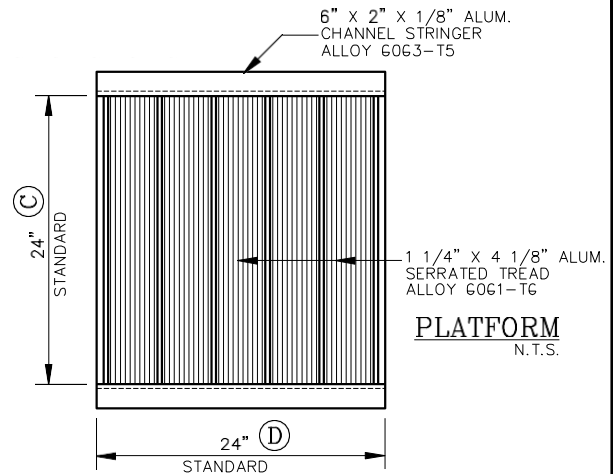

28 - 4120 Ridgeway Dr
 Mississauga, Ontario, L5L 5S9
 P 2899992334 - F 9052672777
 info@taimco.ca

**Aluminum Ship Ladder
 Model SL1488 & 60 Angle**

- _____ QUANTITY
- MILL FINISH
 - POWDER COATING
 - BRONZE ANODIZED
 - CLEAR ANODIZED

SALE NO.

DRAWN :

DATE :

SHEET : _____ OF _____