

Hexagon One Tier Steel Structure Park Gazebo
GAZH1T

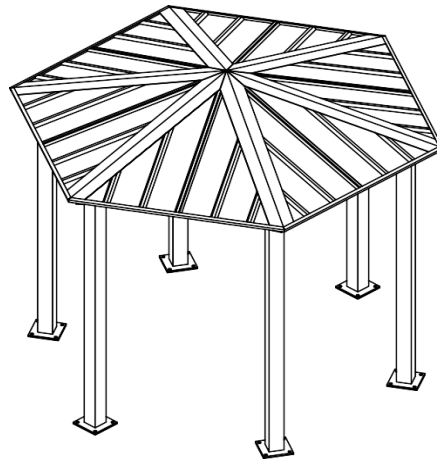

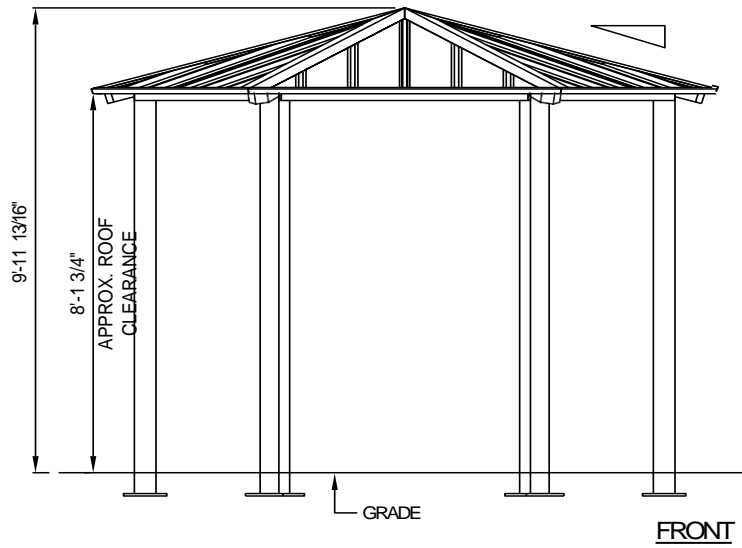

PLAN

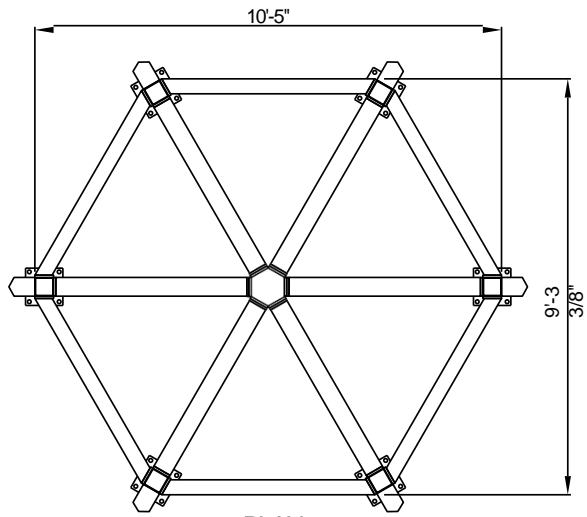
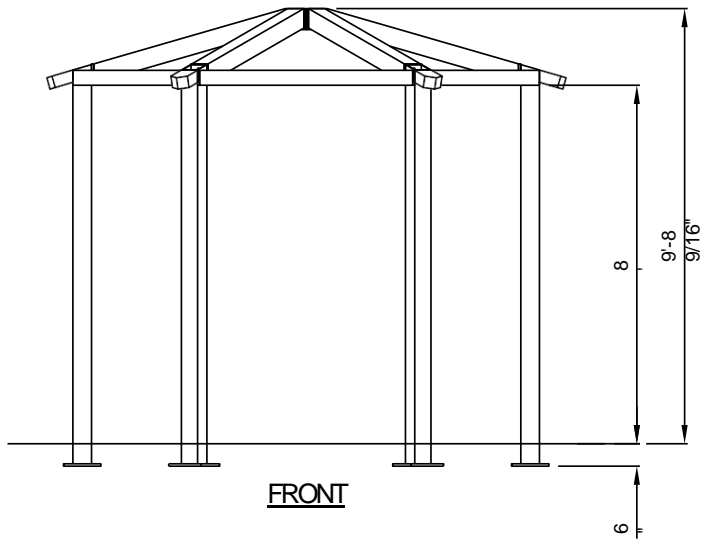
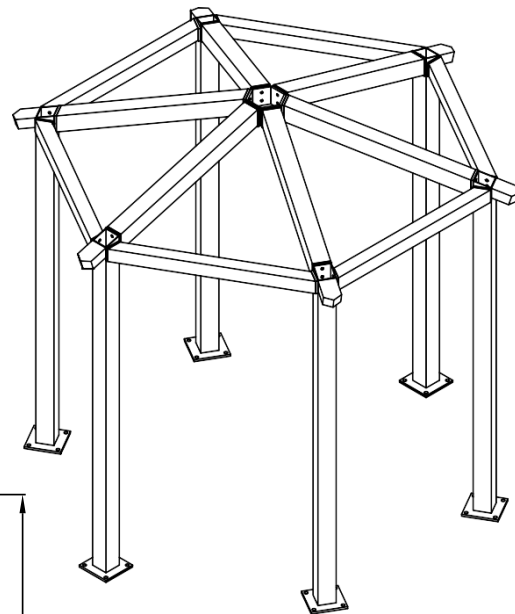

FRONT

ALL STRUCTURAL COMPONENTS WILL BE:
 TUBE: ASTM A500 GRADE B
 PLATE: ASTM A36
 BOLTS: ASTM A325
 NUTS: ASTM A563
 WELDING: GMAW

NOTE:
 COLUMN SIZE: HSS5X5X0.1875

FASTENERS

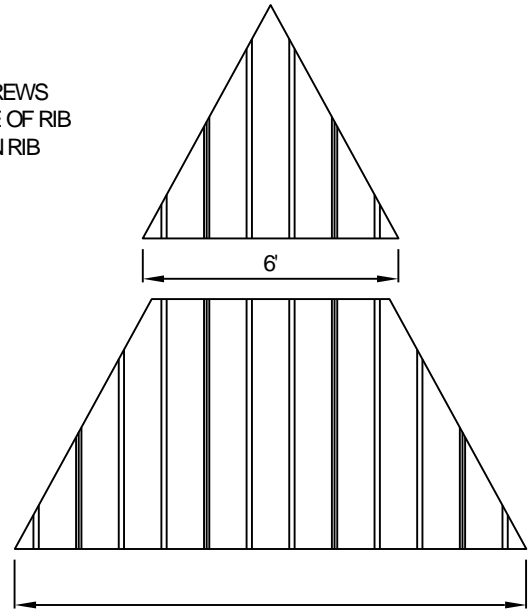
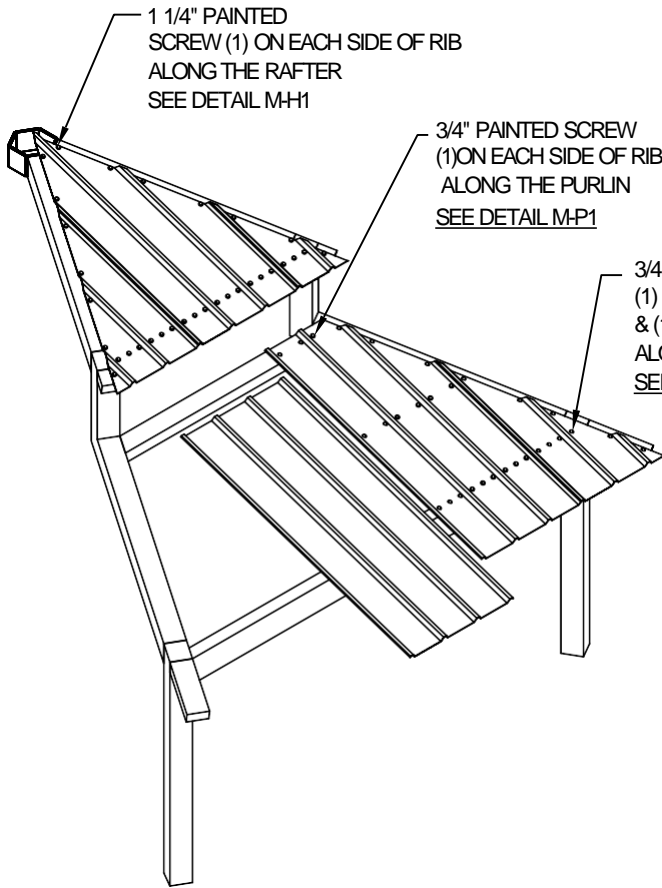
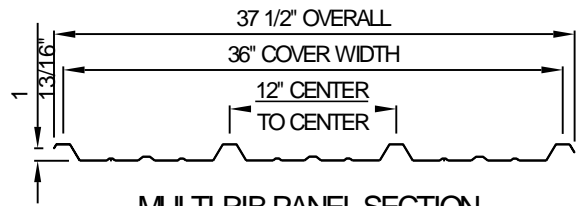
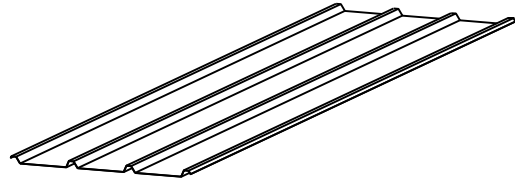
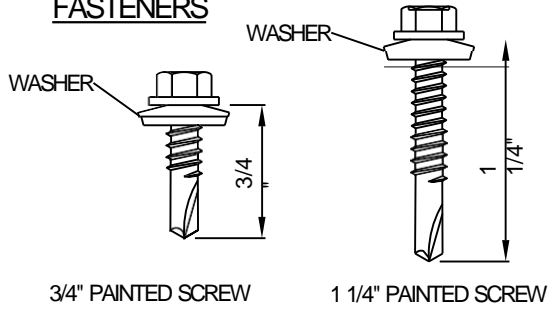

Z (INSIDE OF BUILDING)



LOADS TO FOUNDATION
(KIPS, IN-KIPS)

LOAD COMBINATION	FOUNDATION LOADS				
	AXIAL(X)	SHEAR(Y)	SHEAR(Z)	MOMENT(Y)	MOMENT(Z)
DL	0.69	0.00	0.00	-0.14	0.00
SL	2.30	0.00	0.00	-0.52	0.00
W-UPLIFT	-1.83	0.35	0.01	-0.33	37.78
W-FY	-1.83	0.35	0.01	-0.33	37.78
W-FZ	-1.76	0.18	-0.31	33.55	19.12
E-FY	0.00	0.46	0.00	0.00	49.29
E-Z	0.09	0.00	0.26	-49.34	0.00

THESE FOUNDATION LOADS ARE FOR ESTIMATING PURPOSE ONLY. THE ACTUAL LOADS WILL BE DETERMINED IN THE FINAL ENGINEERING

NOTES:

- TABLE SHOWS UNFACTORED SERVICE LOADS
- A FOUNDATION DESIGN HAS NOT BEEN PERFORMED BY ICON SHELTER SYSTEMS INC.
- A LICENSED ENGINEER FAMILIAR WITH SOIL CONDITIONS AT CONSTRUCTION SITE MUST PERFORM A FOUNDATION DESIGN.
- THE STRUCTURE HAS BEEN ENGINEERED AS AN OPEN STRUCTURE.
- CONSULT ICON SHELTER SYSTEMS INC. IF THE STRUCTURE IS TO BE ENCLOSED.
- COORDINATES ARE LOCAL TO THE COLUMN

DEFINITIONS:

DL = SERVICE LEVEL DEAD LOAD REACTION WITH THE GREATEST AXIAL LOAD SL = SERVICE LEVEL SNOW LOAD REACTION WITH THE GREATEST AXIAL LOAD
W-UL = SERVICE LEVEL WIND LOAD REACTION WITH THE GREATEST UPLIFT LOAD W-Y = SERVICE LEVEL WIND LOAD REACTION WITH THE GREATEST MAGNITUDE OF SHEAR IN THE LOCAL Y DIRECTION
W-Z = SERVICE LEVEL WIND LOAD REACTION WITH THE GREATEST SHEAR VALUE ACTING IN THE SAME DIRECTION AS THE DL SHEAR LOAD
E-Y = SERVICE LEVEL SEISMIC LOAD REACTION WITH THE GREATEST MAGNITUDE OF SHEAR IN THE LOCAL Y DIRECTION
E-Z = SERVICE LEVEL SEISMIC LOAD REACTION WITH THE GREATEST MAGNITUDE OF SHEAR IN THE LOCAL Z DIRECTION

