



# Maintenance Booklet

Tuba/Euphonium

# Introduction

Tubas and Euphoniums employ two types of valve systems, Rotary Valves and Piston Valves. Some instruments use both types. Piston and Rotary Valves operate at very close tolerances. All brass instruments have Adjustable Tuning Slides. All slides and valves require regular maintenance and lubrication, and the instruments should be cleaned regularly in order to continue working properly.

The procedures outlined here are designed to help you properly maintain your instrument. Some are very simple, and some are more complicated. Having a qualified repair technician show you how to properly execute the more complicated procedures the first time can make learning them easier. There is a list of tools and supplies needed at the beginning of each procedure. We recommend reading through each procedure completely before you begin. *Note: underlined terms in the procedures are shown in the diagrams and indicated by a letter.*

Please feel free to call or email us if you have questions.

## Table of Contents

<b>I. Lubricating Rotary Valves</b>	<b>Page 2</b>
<b>II. Cleaning and Lubricating Piston Valves</b>	<b>Page 3</b>
<b>III. Maintaining Adjustable Tuning Slides</b>	<b>Page 4</b>
<b>IV. Cleaning Interior and Exterior of the Instrument</b>	<b>Page 5</b>
<b>V. Valve Diagrams, Tuning Slide Diagram</b>	<b>Pages 8, 9, 10</b>

## **I. Lubricating Rotary Valves**—recommended to be done at least once a week.

Rotary valves use a rotor which turns in a casing to redirect the air column through additional tubing. Rotary valves *do not* need to be disassembled to be properly lubricated.

Rotary valves do need to be disassembled for cleaning, but require tools, time and care. We recommend having rotary valves disassembled by a qualified technician. If you prefer to do the job yourself, directions are available from The Tuba Exchange.

### Tool/Supply List:

Light Bearing/Linkage Oil

*Hetman #13 Light Bearing and Linkage Oil or, #13.5 Medium*

Lightweight Rotary Oil

*Hetman #11 Light Rotor or #12 Rotor Oil*

Soft Cloth

Toothbrush or Q-tip

Padded work surface

In order to properly lubricate a Rotary Valve, you need to get a high quality Light Bearing Oil to two Bearing Surfaces which are enclosed inside the Rotor Casing (Rotary Valve Diagram, letter F), and a lighter viscosity, high quality Rotor Oil to the Rotor Body, also enclosed within the Rotor Casing. (The Back and Front Bearings and Surfaces and Rotor Body are not shown in diagram, because they are enclosed.) Use the following procedures for oiling:

1. To lubricate the Back Bearing, lay the instrument on a padded surface with the levers down to access the Valve Cap (J). Unscrew the Valve Cap to remove it.
2. Make sure you keep the Valve Caps in the proper order so you can put the same Valve Cap back on its corresponding Rotor Casing. Some manufacturers mark the inside of each cap either with numbers, lines, or dots to allow it to be put back on its proper Rotor Casing.
3. Once you have removed the Valve Cap, you will see the Short Stem (G) in the center of the exposed Back Bearing Plate (H). Put one or two drops of high quality Bearing Oil on the Short Stem. Oil will seep into the enclosed Back Bearing.
4. Clean any debris from the Valve Cap threads with a soft cloth, Q-tip or toothbrush. Replace the Valve Cap so that it is finger tight. Be careful not to get the threads crossed when replacing the caps.
5. To lubricate the Front Bearing, turn the tuba over so that the finger levers are up.
6. Find where the Lever Linkage Arm (A) attaches to the valve at the

Stop Arm (B). Starting at the top of the Stop Arm where the Lever Linkage Arm is attached, look down the side of the Stop Arm until you see the small space (approx. 1/16th of an inch) between the bottom of the Stop Arm and the end of the Rotor Stem Sleeve (D). Apply a drop of high quality Bearing/Linkage Oil to the Rotor Stem (C) in that space. The oil will seep down to the Front Bearing Surface.

7. Use a light Rotor Oil for the inside of the Rotor Casing and Rotor Body. To access the inside of the Rotor Casing and Rotor Body, remove the Tuning Slide that allows most direct access to the inside of the Rotor Casing. Oil can be dropped into the open Slide Receiver Tube. If the instrument has a down pull Main Tuning Slide (as on most euphoniums and CC and F tubas), you can stand the horn on the bell, remove the Main Tuning Slide and drop oil into the Slide Receiver that is closest to the rotors. However you choose to deliver the oil, work the rotor levers as you apply oil to coat the rotors. The tubes used to get oil to the rotors should be kept clean to avoid running grease and dirt into the Rotor Casing (see section III for directions on cleaning tuning slides).

**II. Cleaning and Lubricating Piston Valves**—Lubricating only is recommended to be done at least three times a week—use procedure numbers 1,2,8,9 & 10. Cleaning and lubricating should be done once a week—use numbers 1–10.

Piston Valves use a piston which moves up and down in a cylindrical casing to redirect the air column through additional tubing. Piston valves are easily disassembled, with care, for cleaning and lubrication.

Note: Never force a piston into or out of its casing. Doing so could damage the piston, piston guide or casing, causing malfunction. If a piston cannot be removed from or replaced into its casing easily, take the instrument to a competent repair technician.

Tool/Supply List:

High Quality Piston Oil

*Hetman #1, 2 or 3 Piston Oil*

Cleaning Rod (Available at music dealers)

Lint Free Cloth

Toothbrush

Q-tips

1. Unscrew the Top Valve Cap (see Piston Valve Diagram, letter C) from the Piston Casing.
2. Carefully remove the Piston Body (H) by pulling it straight up and out of its casing. Look at the top of the Piston Body under the Top Valve Cap, to identify how the Piston Body is marked. The mark may be under the Felt (D) and/or Cork (E). Most pistons are numbered to correspond with the casing they belong in.

3. Unscrew the Bottom Valve Cap (L), and remove the Bottom Valve Cap and Valve Spring (K). Most tubas and euphoniums use a spring between the bottom cap and bottom of the piston. If the spring is tapered, notice which end of the taper is up and replace the spring the same way.
4. Insert a piece of soft lint free cloth through the small loop at the end of the cleaning rod. Wrap the cloth over the end of the rod and twist/wrap the cloth around the length of the rod. The wrap should be approximately the same diameter as the inside of the Valve Casing (J), and the metal rod end and shaft should be covered to avoid gouging the inside of the Casing. Holding the rod handle, and the end of the cloth, insert the rod into the Casing, working the rod in and out of the Casing to rub out any dirt and old oil (be careful of sharp edges on the Casing ends—they can be hard on the knuckles).
5. Clean debris and oil from inside the Bottom Cap with toothbrush or Q-tip. Re-install the Bottom Cap.
6. Drop the Valve Spring into the Casing. If there is a recessed or raised ring in the center of the inside of the Bottom Cap, make sure the Spring is seated in or around that center. If necessary, carefully move the Spring to its position with the end of the cleaning rod. Use care to avoid gouging the inside of the Casing.
7. Wipe oil and debris from the outside of the Piston Body with the cloth.
8. Apply one or two drops of high quality Piston Oil to the side of the Piston Body at the bottom end.
9. Carefully insert the Piston Body into its Piston Casing. Make sure the protruding tab on the piston Valve Guide (F) goes easily into the Valve Guide Track (G) on the inside of the Casing.
10. Clean any debris from inside the Top Valve Cap and thread it onto the top of the Valve Casing.

**III. Maintaining Adjustable Tuning Slides**—Lubricating recommended to be done monthly—use procedure numbers 1,4,5 & 6. Cleaning and lubricating should be done at least once every 2 to 3 months. Each slide should be moved daily. If the slides are not moving freely, lubricate at that time.

Moveable Tuning Slides are used on all brass instruments to adjust the intonation of the whole instrument and the individual valve tubing. In most cases, they are easily removed and require lubrication.

Tool/Supply List:

Cleaning Rod

Lint Free Cloth

Lubricant (use one of the following, or other high quality lubricant)

*Anhydrous Lanolin, Bearing Grease, Commercial Slide Grease, etc.*

1. Notice the location of each Tuning Slide (Tuning Slide Diagram, A). Some instruments have as many as 10 different tuning slides. On many instruments, some tuning slides will fit in more than one location. The slides should be returned to their original location. Slides are not usually marked. Either clean and lube slides one at a time, or lay the slides out in such a way that you are assured of getting the slides back in their correct receiver tubes.
2. Remove the Tuning Slide and wipe off the old grease from the Inner Slide Tubes (B) with a lint free cloth. (It is a good idea to get in the habit of always pressing the valve or key down before removing and replacing the tuning slide. This allows the slide to be removed or inserted without producing a strong vacuum in the slide tubes, which might cause damage to the instrument.)
3. Wrap the cleaning rod as described in section II, #4 above. Insert the rod into the Outer Slide Tube (C) and move in and out to remove old grease and dirt. Make sure that the metal of the cleaning rod is covered to avoid gouging the inside of the slide tubes.
4. Evenly coat the cleaned Inner Slide Tubes with a thin coating of high quality slide grease. Grease the Inner Slide Tubes by starting at the end of the tubes and working about half way up toward the Slide Crook (D). Do not put too much grease on the slides.
5. If possible, insert one of the two Inner Slide Tubes back into its Outer Slide Tube (in most cases, the Outer Slide Tube is the tube that is permanently attached to the instrument) and work it up and down (or in and out) to evenly distribute the grease. If the tube does not slide smoothly, remove the Tuning Slide and apply more grease by repeating steps 2 and 4. If slide continues to be difficult to move, try step 3, or inspect the tubing for damage. If there is damage, take the instrument to a competent repair technician for repair.
6. Insert both tubes of the Tuning Slide into the Outer Tubes and make sure they move smoothly.

**IV. Cleaning Interior and Exterior of the Instrument**—The following procedure details a light cleaning that should be done to both piston and rotary instruments every few months. If you are cleaning a rotary valve instrument, do not remove the rotors. In steps 8 and 9, do not use soapy water inside of rotary valve instruments—only use fresh water. It is OK to use soapy water in step 4.

Complete cleaning, including disassembly of rotors should be done every 1 to 2 years. We recommend that players have annual or biannual complete cleanings done by a qualified technician. If you would prefer to clean your own rotary valves, directions for disassembly and reassembly of rotary valves are available from The Tuba Exchange.

Tool/Supply List:

Dish Soap

Cleaning Rod

Cleaning Snake (flexible double ended brush)

Tube (or casing) Brush

Piston or Rotor Oil (see I and II)

Linkage oil (see I)

Slide Grease (see III)

Soft Cloths

Padded Work Surface

Drying Towels

Valve felts and corks as needed, if they are worn

1. Remove all piston valves from their casings (see section II, 1 and 2 above). Do not remove rotors from their casings for light cleaning.
2. Remove felts and corks from pistons by unscrewing the Finger Button (Piston Valve Diagram, A) or Valve Stem (B). Keep these parts in order so they can be reassembled with the piston they were removed from. Place pistons in warm soapy water to soak.
3. Remove all moveable tuning slides (see III above).
4. Wipe old grease from outside of tuning slides. Place all tuning slides in a container of warm soapy water to soak (do not use hot water—it can destroy some lacquer finishes).
5. Remove the tuning slides from the soapy water and wipe any remaining dirt or grease from the outside of the tuning slides (the parts that go into the outer slide tubes) with a soft cloth.
6. Clean the inside of the tuning slide tubes using a cleaning snake or tube brush. (The Tuba Exchange offers a cleaning snake with brushes on each end for this purpose). Rinse the tubes inside and out with clear warm water. Towel dry and set cleaned tuning slides aside, open end down to drain.
7. Remove pistons from soapy water and rinse with warm clear water (pistons are hollow—run water through holes in the ends of the pistons to rinse). Wipe dry to remove any dirt or residue. Make sure all deposits of dirt, grease and oil, etc. are removed from the inside of the passageways going through piston valves. Be very careful not to scratch the surface of the piston during this process. Wipe pistons dry and stand the cleaned pistons on end in a safe place to drain.
8. (If you are cleaning a rotary valve instrument, use clear water only for this step, no soap!) Fill the body of the instrument with warm (not hot) soapy water by pouring it down the bell. Get as much water into the instrument as possible. This can be done in a bathtub with a rubber mat underneath, or, outside on a grassy area, if available. Turn the instrument over as needed to work soapy water throughout the tubing.

9. (Rotary valve instruments, clear water only, no soap!) Pour warm soapy water down the outer tuning slide tubes and mouthpipe. These are the tubes that are permanently attached to the instrument. A small funnel helps to do this.
10. Push the cleaning snake (available at The Tuba Exchange) back and forth through the inside of the mouthpipe to remove debris. Clean the inside of the slide tubes that are permanently attached to the instrument with either a cleaning snake, bottle brush, or cloth wrapped cleaning rod (see II, #4). Do not use a screw driver or similar metal tool to push the cloth into the slide tubes. This could result in damaging the inside of the slide tubes by gouging the metal.
11. Clean the inside of piston casings with a soft, lint free cloth, applying the cloth with your fingers only, or by using a cloth wrapped cleaning rod (see II, #4)
12. Clean the inside of all rotor/piston valve caps (one cap for each rotor and two for each piston) using either a soft brush (an old toothbrush works well for this), or a soft cloth. Make sure all dirt and grease are removed from the threads of the valve caps. Rinse in clear warm water and set aside.
13. Silver plated instruments can be polished with a high quality silver polish to remove tarnish. Polish the instrument before reassembly, while it is wet, with a water soluble paste. Do small areas and rinse before the polish dries. This will avoid hard to remove build up of polish around sharp edges on the instrument. If you are polishing a rotary valve instrument without disassembling the rotors and lever linkage, be careful not to get polish into the workings of the rotors or lever linkages.
14. Rinse the entire instrument inside and out with warm water. Make sure all soapy water is removed from the inside of the instrument by rinsing it thoroughly before reassembly.
15. Drain as much water as possible from the inside of the instrument. Dry inside the bell and the outside of the instrument with a soft towel.
16. Reattach valve stems and/or finger buttons and felt pads and corks (if applicable) to their pistons.
17. See III, IV and V for proper lubrication and reassembly of valves and tuning slides.
18. If time allows, let the instrument sit for several hours before putting it in the case. This allows water droplets inside the larger tubes to pool together. Turn the instrument end over end and drain pooled water out through the bell. Wipe dry with a towel as needed.



# Rotary Valve Diagram

- A. Lever Linkage Arm
- B. Stop Arm
- C. Rotor Stem
- D. Rotor Stem Sleeve
- E. Bumper
- F. Rotor Casing
- G. Short Stem
- H. Back Bearing Plate
- J. Valve Cap

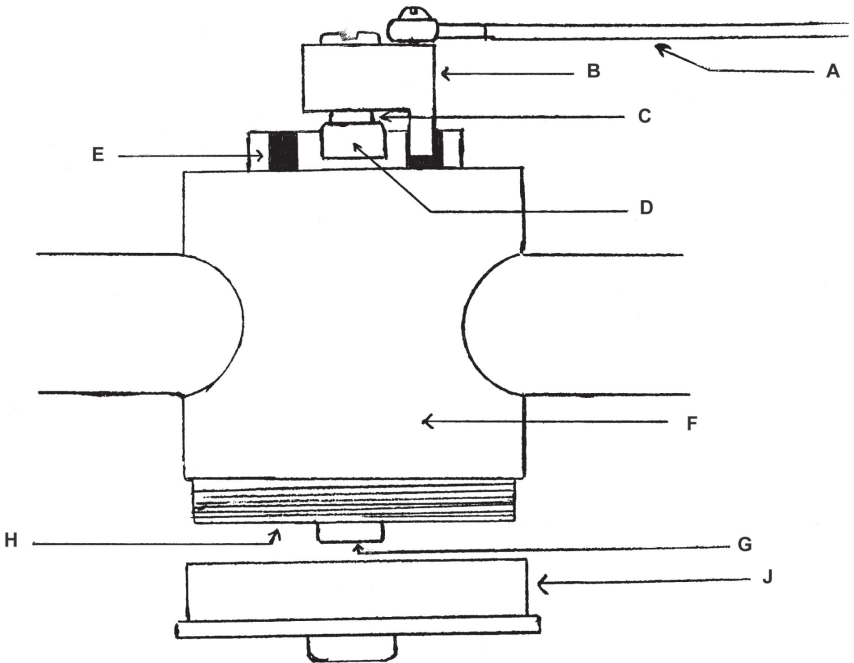

# Piston Valve Diagram

- A. Finger Button
- B. Valve Stem
- C. Top Valve Cap
- D. Felt
- E. Cork
- F. Valve Guide
- G. Valve Guide Track
- H. Piston Body
- J. Piston Casing
- K. Spiral Spring
- L. Bottom Valve Cap

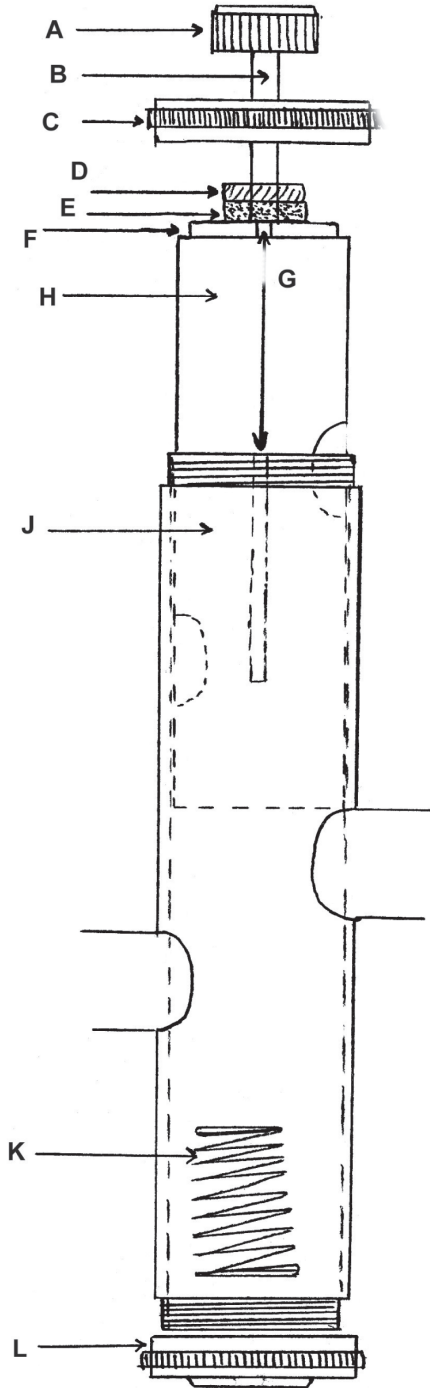

# Tuning Slide Diagram

- A. Tuning Slide
- B. Inner Slide Tubes
- C. Outer Slide Tubes
- D. Slide Crook

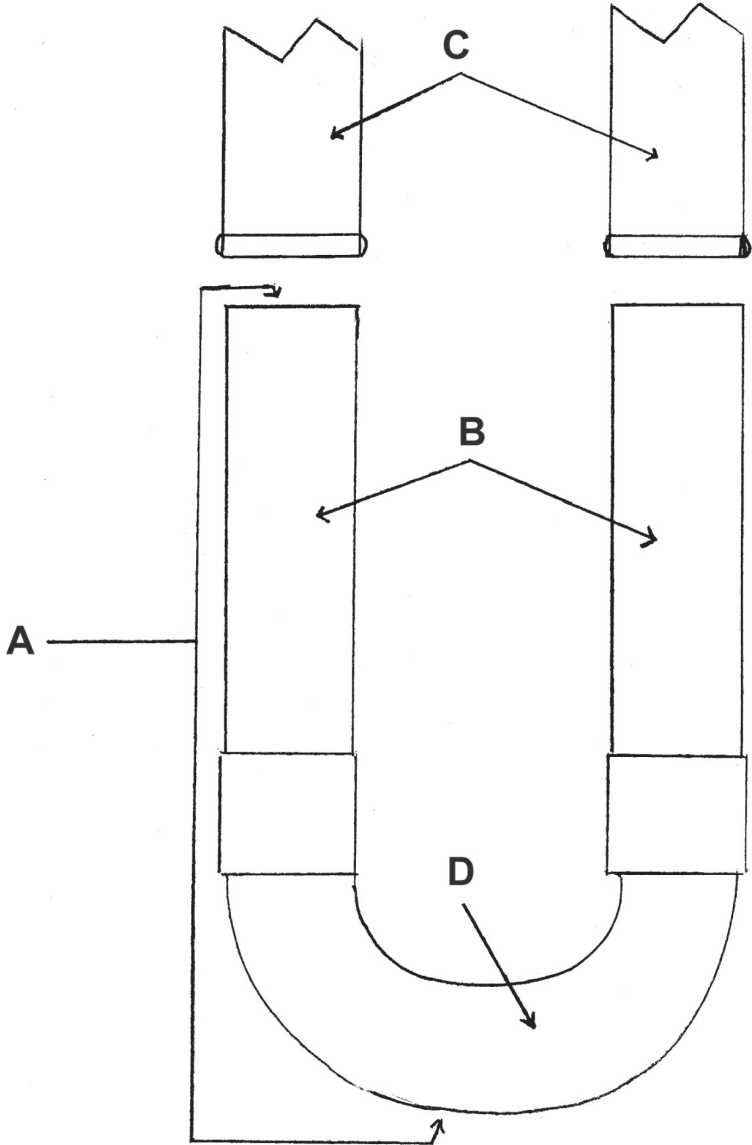



2411 S Alston Ave., Durham, NC 27713 • 1 (800) 869-8822 • Fax: 1 (919) 493-8822

[www.tubaexchange.com](http://www.tubaexchange.com)