

KICKASS[®]

DCDC CHARGER WITH MPPT SOLAR CONTROLLER USER MANUAL



**KADCDC40A-AND
KADCDC20A-AND**

WARNINGS

- To avoid injury or damage to your vehicle ensure the instructions are read carefully and understood.
- Batteries can produce harmful vapour and explosive gases when being charged.
- Ensure batteries are mounted and stored in an area with good ventilation.
- As this Charger has powerful output current, circuit protection such as fuses or circuit breakers must be installed as near as possible to the batteries - refer to wiring diagrams in this manual for correct fitting.

This manual will give you all of the essential information you need to own and operate your new KickAss 20/40A DCDC Charger with MPPT Solar Controller.

The purpose & features of the KickAss 20/40A DCDC Charger with MPPT Solar Controller:

- ▶ **Can charge multiple battery types:**
Compatible with GEL, AGM, WET, CALCIUM or Lithium LiFePO₄.
- ▶ **Prevent your auxiliary battery from draining your start battery:**
Built-in voltage sensing will ensure your start battery charges your auxiliary battery when the vehicle is running. It will then disconnect the start battery from the auxiliary battery when the vehicle is not running.
- ▶ **Ensure your auxiliary battery is being fully charged and maintained:**
Most modern vehicles (especially those manufactured after 2010) do not provide the correct voltages and charge control to safely and completely charge your auxiliary battery. The Charger overcomes this issue by boosting the charge voltage to an optimal output level while ensuring your auxiliary battery is safely charged via its multi-stage charge algorithm.
- ▶ **When your vehicle is not charging, charge from the built-in MPPT solar controller:**
Maximum power point tracking is the most efficient type of solar controller and allows you obtain the maximum amount of charge from your solar panels. When your vehicle is not doing the charging, the built-in MPPT solar controller will let your solar panels do the work.

Stay safe and protect your assets with these protective features:

▶ **Short circuit protection**

The Charger will not turn on unless the batteries are connected correctly.

▶ **Reverse polarity protection**

If you connect positive and negative the wrong way around the Charger will show a fault.

▶ **Over voltage protection**

If the Charger detects voltages connected to its inputs or outputs that are too high it will shut down.

▶ **Over temperature protection**

The Charger will lower its output current if it senses that the unit will overheat.

▶ **Temperature compensation:**

The included temperature sensor will measure the battery temperature and adjust current accordingly to prevent overcharging.

For more technical details, specifications & videos please visit kickassproducts.com.au

SPECIFICATIONS

Charger Model	KADCDC20A-AND	KADCDC40A-AND
OPERATING CONDITIONS		
Input Voltage Range	5-32V DC	
Alternator Input Voltage Range	9-32V DC	
Solar Input Voltage Range	10-32V DC	
Maximum Input Current	27A	47A
Maximum Continuous Charging Current	20A	40A
Maximum Output Power	300W	500W
Fuse Size	40A	60A
No Load Current Draw	<15 mA	
Efficiency	Approx. 93% when full load	
Ambient Operating Temperature	20 °C to +80 °C	
MECHANICAL		
Dimensions	154*120*44mm	192*120*44mm
Weights	870g	950g
IP Rating	IP66	
Certifications	PROP65  CE FC	
BATTERY CAPACITY GUIDE		
Lead Acid (WET,GEL,AGM,CAL)	80 – 200Ah	200 – 500Ah
LiFePO4	50 – 120Ah	120 – 500Ah

BATTERY					
Compatible Battery Type	GEL	WET	AGM	CAL	LiFePO4
Absorption Voltage	14.1V	14.4V	14.7V	15.3V	14.5V
Float Voltage	13.5V	13.4V		13.6V	
Minimum Auxiliary Battery Voltage	9V				0V

INTERGRATED ISOLATOR CONTROL					*30 SEC DELAY BEFORE THE CHARGER WILL CUT IN OR OUT
Input voltage	12V		24V		
Cut in / Cut out Voltage (Ignition override OFF)	CUT IN 13.2V	CUT OUT 12.6V	CUT IN 26.4V	CUT OUT 25.2V	
Cut in / Cut out Voltage (Ignition override ON)	CUT IN 12.2V	CUT OUT 10.5V	CUT IN 24.4V	CUT OUT 21.0V	

DIMENSIONS

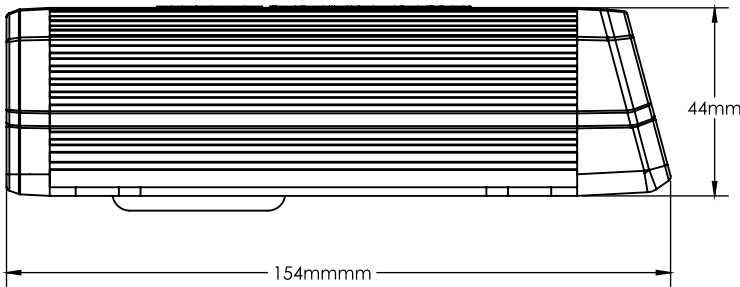
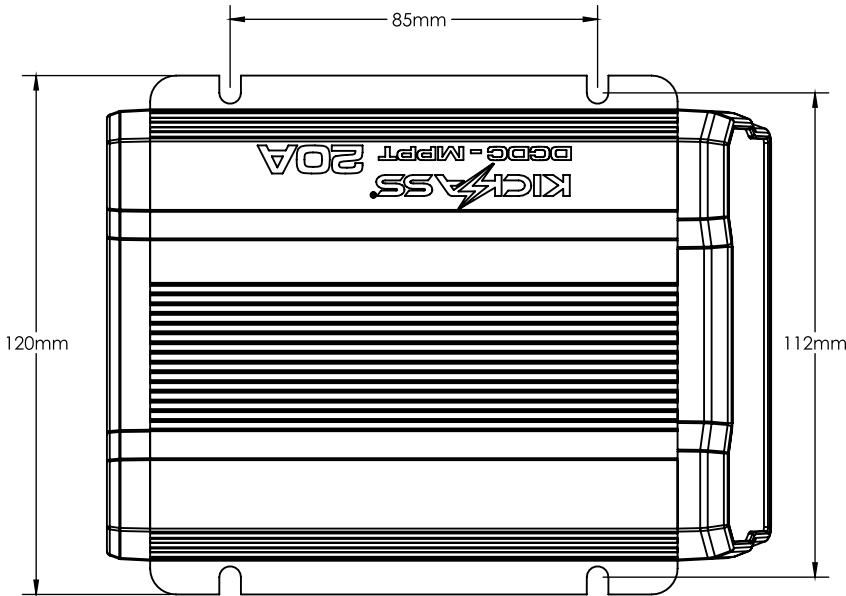

KADCDC20A-AND

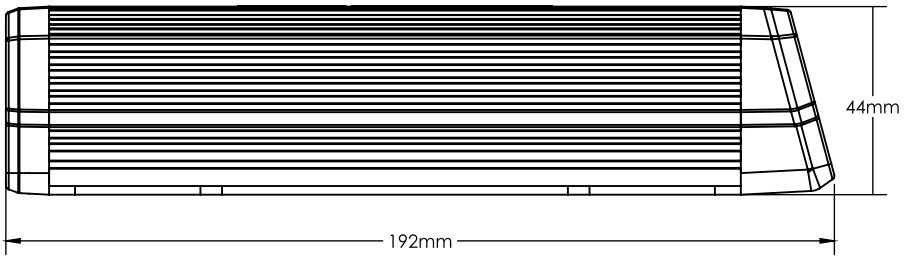
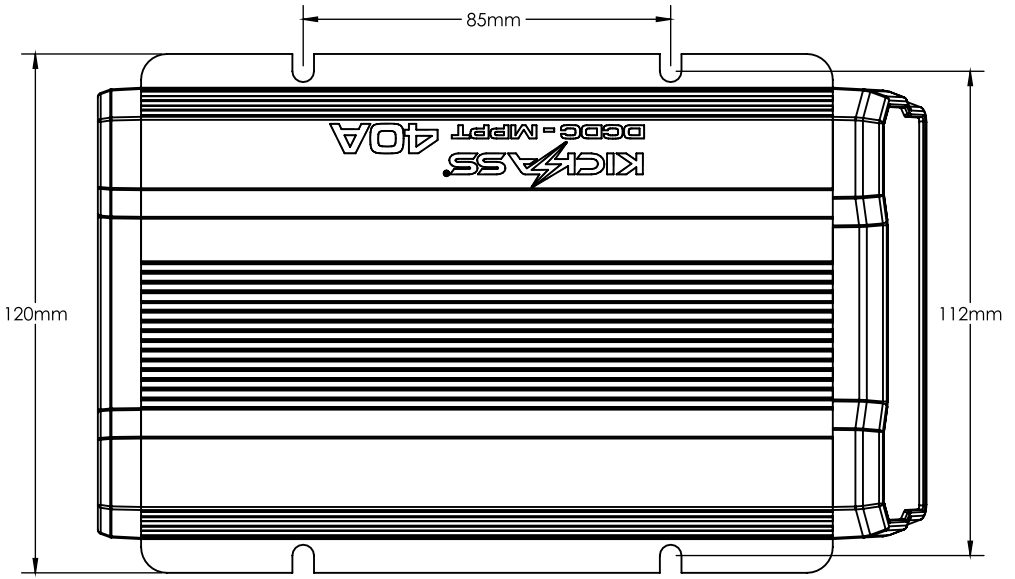

KADCDC40A-AND

PRODUCT OVERVIEW

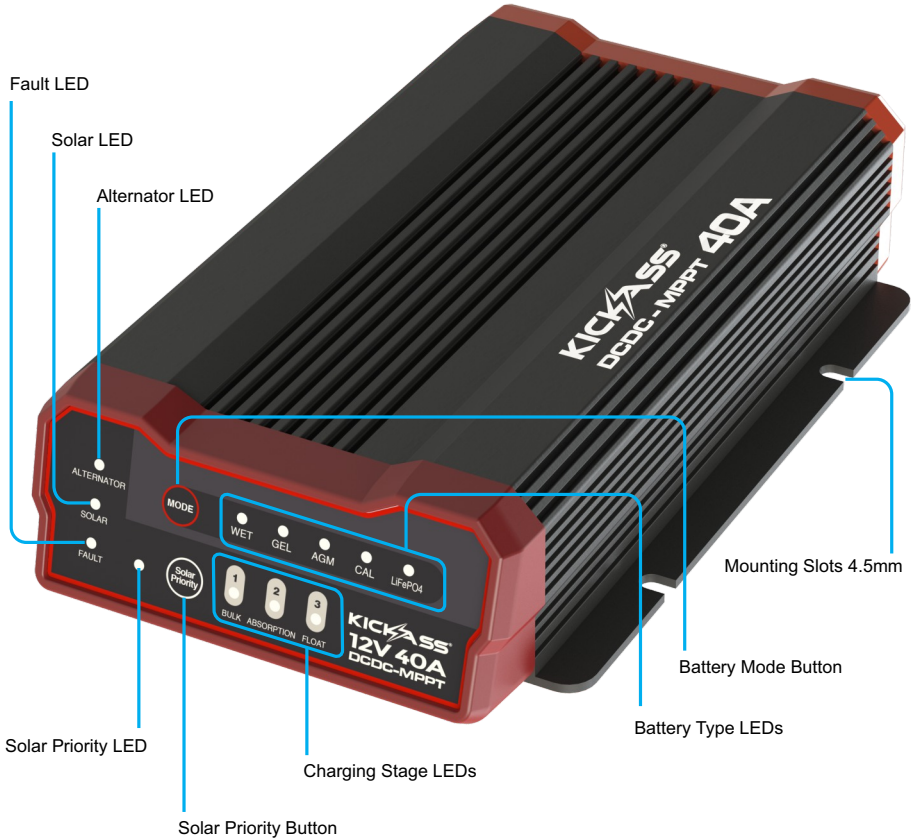

INSTALLATION GUIDE

SAFETY FIRST!

- ▶ The KickAss Charger has been engineered to charge 12 Volt GEL, AGM, WET, CALCIUM or Lithium LiFePO_4 only. Do not use this charger for any other purpose or with any other battery types.
- ▶ Do not attempt to charge known faulty, damaged, frozen or broken batteries.
- ▶ Ensure charger is close to battery, however never mount the charger directly on the battery.
- ▶ Ventilation is very important in battery charging, always ensure battery positioning is in a well ventilated area to allow charging gases to dissipate.
- ▶ Keep sparks or flames away from batteries being charged as they could emit explosive gases.
- ▶ Always check the batteries and charging system periodically to ensure no faults occur.
- ▶ Ensure all cabling is secure and cannot be cut, broken or short circuited.
- ▶ Battery acid is corrosive. If acid comes into contact with skin or eyes, please seek medical advice.
- ▶ Never connect this charger to mains supply.
- ▶ We recommend fitting a 50-75 amp fuse on both the input and output sides of the charger such as the SKU: KAMAXIFHAND or SKU: KAFUSECOVER-KIT to protect cables from short circuits etc.

MOUNTING

It is most important to mount your KickAss Charger as close as possible to your auxiliary battery and be sure to keep your charger away from sources of heat. eg. Turbos and exhaust pipes. This will ensure maximum performance out of your charger.

WIRING SIZE

To make sound electrical connections, the battery cable should be the correct size and the correct terminals should be crimped or soldered.

CABLE SIZING

The table below outlining the required cable size for a given install length.

Please refer to this table for Vehicle Input, Solar Input, Ground and Battery Output cable thickness requirements. Always choose a wire cross sectional area equal to or greater than what is specified below.

Part Number	Cable Install Length		Recommended Wire Cross Section (mm ²)	Closest (BAE, B&S, AWG)	Recommend KickAss Wiring Kit
	meter(m)	feet(ft)			
KADCDC20A-AND	1 - 6.5	3 - 21	7.71	8	KAPRDBWK8MMPP
	6.5 - 8	12 - 26	13.56	6	KAHDBWKPP80
KADCDC40A-AND	1 - 6.5	3 - 21	13.56	6	KAHDBWKPP65
	6.5 - 8	21 - 26	13.56	6	KAHDBWKPP80

Note:

- Always use a fuse in-line for all connections to the starter and aux battery!
- The input and output negative cables labeled Ground 3 and Ground 2 should be connected at the battery negative poles for improved performance.

For more information or assistance, see installation videos at kickassproducts.com.au

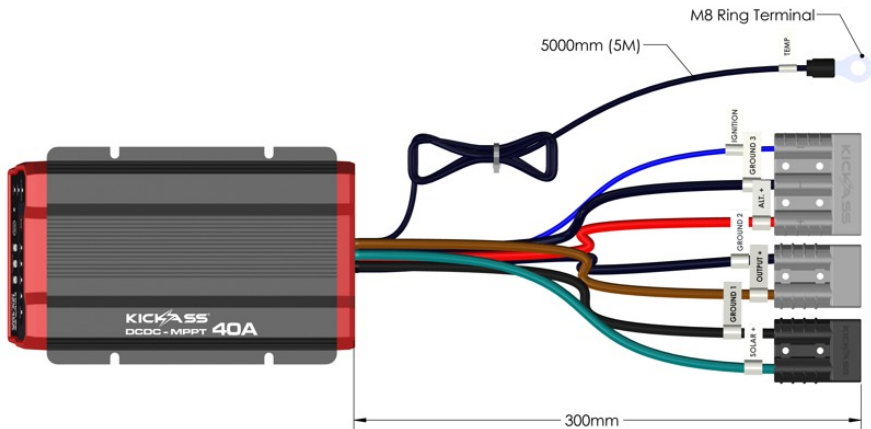

WIRING DIAGRAM



BLUE - IGNITION OVERRIDE 1.5mm²



FUSE BOX
 5A
 10A
 FUSE BOX SKU: KAHDDBWKP80
 PART NUMBER: KAHDDBWKP80

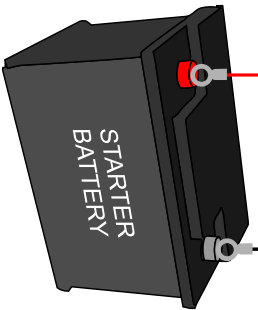

STARTER BATTERY



BOA

ALT IN

KICKASS

KICKASS



KICKASS HEAVY DUTY PLUG & PLAY WIRING KIT
 SKU: KAHDDBWKP85: 6.5M KIT
 SKU: KAHDDBWKP80: 8M KIT

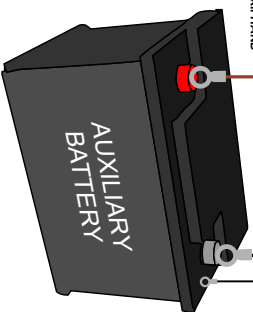

AUXILIARY BATTERY

KICKASS IN-LINE MAX FUSE - KAMKMHAND



BOA

BLACK - TEMPERATURE SENSOR



KickAss DCDC-40A

SOLAR

KICKASS 5M EXTENSION LEAD KAFVAND05

FUSEBREAKER (OPTIONAL)

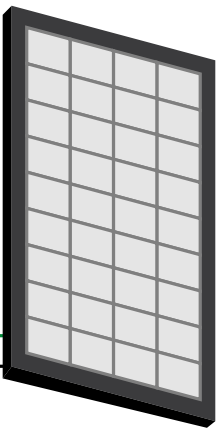

SOLAR PANEL

NOTE: DC-DC CHARGER AS CLOSE AS POSSIBLE TO THE AUXILIARY BATTERY

* NOTE: Ignition override used only if required.
 ⚠ CAUTION: Check model specification for solar input.
 ⚠ CAUTION: Always ensure fuses are installed.

WIRING DIAGRAM - SOLAR PANEL ONLY

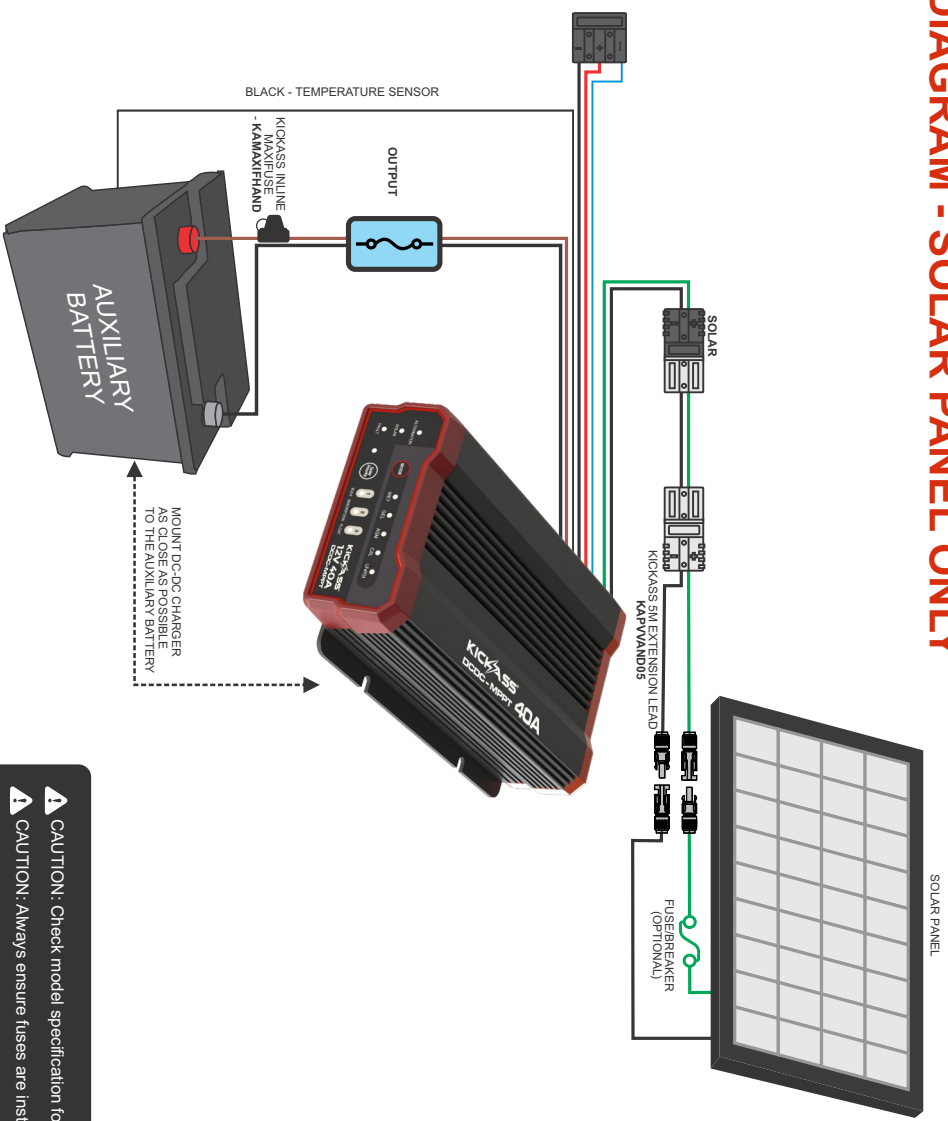

MOUNT DC-DC CHARGER AS CLOSE AS POSSIBLE TO THE AUXILIARY BATTERY

CAUTION: Check model specification for solar input
CAUTION: Always ensure fuses are installed

CHOOSING THE BATTERY TYPE

The battery type setting must be confirmed during device installation. When the auxiliary battery is connected, press and hold the Mode button for 2 ~ 4 seconds, upon releasing the button, the battery type LED will move to the next position. Repeat the steps until required battery type LED is selected. Battery type setting is now programmed. The selected battery type will be saved as the new default.

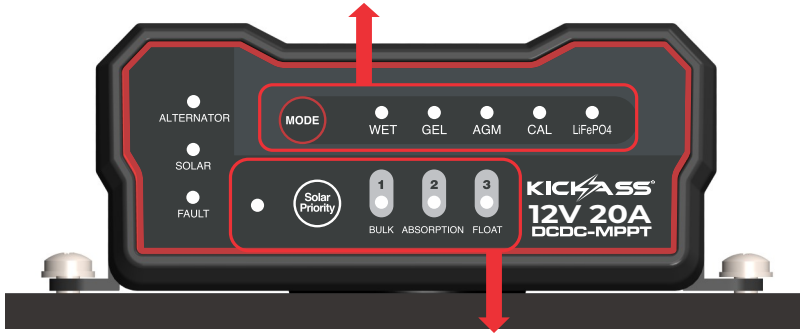

CHARGING STAGE PROFILE

STAGE	DESCRIPTION				
BULK	GEL 100% Current Until 14.1 V	AGM 100% Current Until 14.7 V	WET 100% Current Until 14.4 V	CALCIUM 100% Current Until 15.3 V	LifePO4 100% Current Until 14.5 V
ABSORPTION	Constant 14.1 V Until 2.6A	Constant 14.7 V Until 2.6A	Constant 14.4 V Until 2.6A	Constant 15.3 V Until 2.6A	Constant 14.5 V Until 2.6A
FLOAT	13.5V at 100% Current Max	13.4V at 100% Current Max	13.4V at 100% Current Max	13.6V at 100% Current Max	13.6V at 100% Current Max

NOTE:

When in FLOAT stage, the battery is fully charged. At float stage, when the battery voltage drops to 0.3V below the specified float voltage for the battery type connected, the charger will restart charging from the BULK stage.

UNDERSTANDING SOLAR, ALTERNATOR & CHARGING LIGHTS

Standby Mode

No inputs detected. Once the Aux battery has been connected and is within the detectable voltage range, the battery type LED will short flash to indicate the device is in standby mode and no input sources are detected



Battery type selection mode

Press and hold the Mode button for 2 ~ 4 seconds, upon releasing the button, the battery type LED will move to the next position. Repeat the steps until required battery type LED is selected. Battery type setting is now programmed and charger will return to Standby mode after a short time.



Standby Mode Alternator input detected

With no Solar connected or detected and the Alternator is the only available input source, the input LED will short flash to indicate input voltage is below the set cut-in voltage. Charger is still in Standby mode and has not begun to charge the battery.



Standby Mode Alternator and Solar inputs detected

Both input sources are detected but neither has reached the set cut in voltage range. By default Alternator input has priority and will provide power to charge the battery. Solar priority has not been selected and indicator LED is on.



Charging with Alternator or Solar only

Once the input source reaches the set cut-in voltage, charging will begin. The battery type LED will turn solid and the active charge stage LED will come on and remain solid, while the input source LED will continue to flash.

ALTERNATOR ONLY



SOLAR ONLY



Absorption Charge Stage

ALTERNATOR ONLY



SOLAR ONLY



Float stage

Input source LED will change to a long flash sequence when charging stage transfers to float. Battery is now fully charged.

ALTERNATOR ONLY



SOLAR ONLY



Charging with Alternator as priority (default)

Once the Alternator input voltage reaches the set cut-in voltage, charging can begin. The battery type LED will turn solid and the active charge stage LED will come on and remain solid, while the input source LED will continue to flash. Solar input LED will remain solid while source is available. The charger will transition through the different charging stages as previously shown, until the battery is full.



Charging with Solar as priority - Setting Solar Priority mode

The function of Solar Priority mode is to allow the charger to check for available solar input before choosing the alternator as the input source. To do this, the charger will assess the state of charge of the battery and decide if the available solar can effectively supply enough charge or choose the alternator as the best input source.

The Solar Priority function can be set at any time, once the Aux battery has been connected. To set Solar Priority, press and hold Solar Priority button for 2 ~ 4 seconds, then release the button, to change the priority. The Solar Priority indicator LED will start to flash.



Lithium BMS Sleep Mode & Recovery Feature:

Most lithium batteries are built with a Battery Management System (BMS) inside to protect the battery from over charging, over discharging and extreme temperature changes.

One of the key functions of the BMS is to protect your battery by internally disconnecting the load¹ when voltage drops below specific parameters, this will then result in the battery entering into a “sleep” mode.

¹ (Load includes any accessories and/or device/s drawing charge from the battery. Eg: fridges, pumps, food sealers, etc)

The KickAss DCDC MPPT Solar Battery Controller has a lithium battery recovery function. This function has been designed to recover lithium batteries from a sleep mode.

Lithium Battery Recovery Mode Procedure

First disconnect any load connected to the lithium battery. Secondly connect Alternator Input or Solar Input to the KickAss DCDC Charger with MPPT Solar Controller. Thirdly connect the output from the DCDC charger to the lithium battery. When the DCDC Charger with MPPT Solar Controller input charging voltage reaches the relevant cut in voltage, the DCDC Charger with MPPT Solar Controller will automatically try to activate the battery every minute. When DCDC Charger with MPPT Solar Controller attempts to activate the battery, if a open-circuit or short-circuit error is detected, the DCDC Charger with MPPT Solar Controller will enter standby mode until the next activation attempt. If the activation attempt is successful, DCDC Charger with MPPT Solar Controller will initiate the regular three stage charging sequence.

Once the DCDC Charger with MPPT Solar Controller indicates the battery has reach the FLOAT charge state, the battery has been fully recovered and loads reconnected.

FAULT CODES

If the fault light is flashing, please refer to the fault codes below for diagnostics.



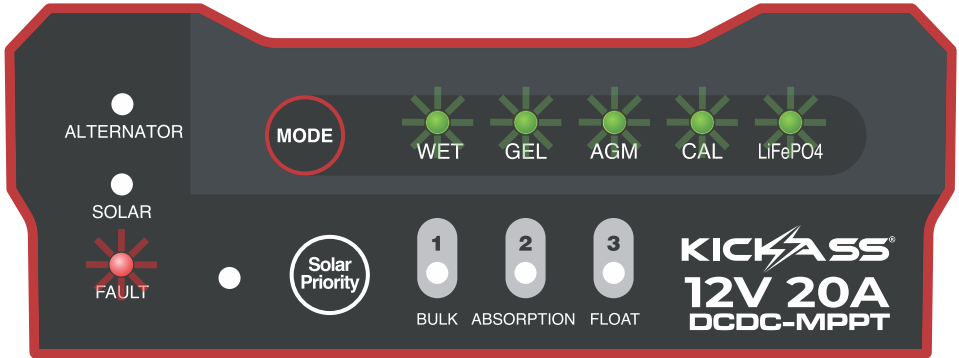





















Note: Only the selected battery type LED will flash when the device detects a fault condition.



Alternator (green)	Solar (green)	Battery Type (green)	Solar Priority (Green)	Fault (red)	Fault	Solution
					Over voltage detected at alternator input	Check alternator battery voltage
					Over voltage detected at solar input	Check solar panel open circuit voltage
					Over voltage detected at output	Check auxiliary battery voltage
					Over temperature	Let the unit cool down for some time or improve ventilation

TROUBLESHOOTING

The following table provides some additional fault finding advice should any potential issues arise with the system installation, or unexpected system behavior is identified after normal operation.

Alternator (green)	Solar (green)	Battery Type (green)	Solar Priority (Green)	Fault (red)	System Behavior	Recommended Troubleshooting Procedure
			 / 		No voltage detected at alternator and solar input	<ul style="list-style-type: none"> Check alternator and solar panel voltages. Check system wiring for potential connection issues.
			 / 		Low voltage detected at alternator input (Voltage is below cut-in range)	<ul style="list-style-type: none"> Check alternator battery voltage. Check system wiring for potential connection issues. Check alternator operation.
			 / 		Low voltage detected at solar input (Voltage is below cut-in range)	<ul style="list-style-type: none"> Check solar panel voltage. Check system wiring for potential issues.
			 / 		Low voltage detected at alternator or solar input (Voltage is below cut-in range)	<ul style="list-style-type: none"> Check alternator battery voltage. Check system wiring for potential connection issues. Check alternator operation. Check solar panel voltage. Check system wiring for potential issues.

FCC COMPLIANCE STATEMENT

This device complies with part 15 of the FCC Rules. Operation is subject to the following two conditions: (1) this device may not cause harmful interference, and (2) this device must accept any interference received, including interference that may cause undesired operation.

Note: This equipment has been tested and found to comply with the limits for a Class B digital device, pursuant to part 15 of the FCC Rules. These limits are designed to provide reasonable protection against harmful interference in a residential installation. This equipment generates, uses, and can radiate radio frequency energy and, if not installed and used in accordance with the instructions, may cause harmful interference to radio communications. However, there is no guarantee that interference will not occur in a particular installation.

If this equipment does cause harmful interference to radio or television reception, which can be determined by turning the equipment off and on, the user is encouraged to try to correct the interference by one or more of the following measures:

- Reorient or relocate the receiving antenna.
- Increase the separation between the equipment and receiver.
- Connect the equipment to an outlet on a circuit different from that to which the receiver is connected.
- Consult the dealer or an experienced radio/TV technician for help.

Changes or modifications to this product not authorized by KickAss could void the electromagnetic compatibility (EMC) and wireless compliance and negate your authority to operate the product.

This product has demonstrated EMC compliance under conditions that included the use of compliant peripheral devices and shielded cables between system components. It is important that you use compliant peripheral devices and shielded cables between system components to reduce the possibility of causing interference to radios, television sets, and other electronic devices.

Exposure to radio frequency energy. The radiated output power of this device meets the limits of FCC/IC radio frequency exposure limits. This device should be operated with a minimum separation distance of 20 cm (8 inches) between the equipment and a person's body.

NEED HELP?

KickAss constantly updates frequently asked questions, troubleshooting, videos and specifications, please visit: kickassproducts.com.au for the most up to date information.



THANK YOU FOR CHOOSING

KICKASS[®]

DC-DC CHARGERS



For more information please visit us at:
kickassproducts.com.au