

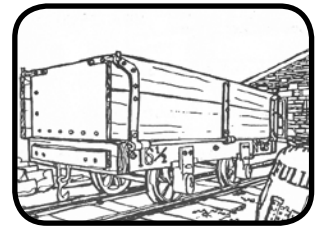

MPM8 • PENRHYN QUARRY RAILWAY FULLERSITE WAGON



The Penrhyn Quarry Railway (1879 - 1962) carried quarry output from Bethesda to Porth Penrhyn. After the First World War a by-product of slate quarrying was developed in finely graded slate powder, given the trade name 'Fullersite'. This was used as a filler for things such as road asphalt mixed with bitumen. The bagged product was conveyed from the quarry in a fleet of 4 wheeled wagons designed specifically. A total of approximately 90 wagons of 2 types were built in small batches of 20 or so at a time - lift out sides, with heavy timber staunchions and dropside. Our kit is of a wagon in the last batch, No. 85, with iron floor and ends and 2 plank drop sides. A similar wagon may be viewed at Penrhyn Castle Museum.

BUILDING NOTES

The exploded diagram shows the assembly in detail but the following notes may be useful. Remove parts from the 'sprue' **carefully**. Assemble one end and one side to floor, having dry fit first to check. Fit second end, ensuring squareness of ends to each other. Dry fit second side and fix, trapping wheel sets in the process.

'009' type couplings are supplied **but not** 'Bemo' loops, epoxy resin brass wire to locating pips on under side and trim to suit loop. Fluid cement (Mek Pak) is recommended for assembly of this kit.

PAINTING NOTES

Ex works

Black • Floor, ends, axleboxes, strapping and front face of 'buffing' strake

Natural wood • Sides, underframe, headstocks and 'buffing' strake

'Natural wood' - paint with pale cream or light oak and weather to taste with thin wash coats of light grey, in service these wagons presented an overall dusty appearance.

ABOUT MERIDIAN MODELS

Founded in 1973 and driven forward by the late Dave Brewer of the Greenwich & District Narrow Gauge Railway Society (G&DNRS), with Pete Wilson and other collaborators joining along the way, Meridian Models grew into a well-respected producer of detailed locomotive and rolling stock kits in 009.

Following Pete Wilson's decision to retire in 2015, Narrow Planet has taken on the production and distribution of the plastic rolling stock kits of the Meridian range. If you have any queries about the model or instructions please get in touch.

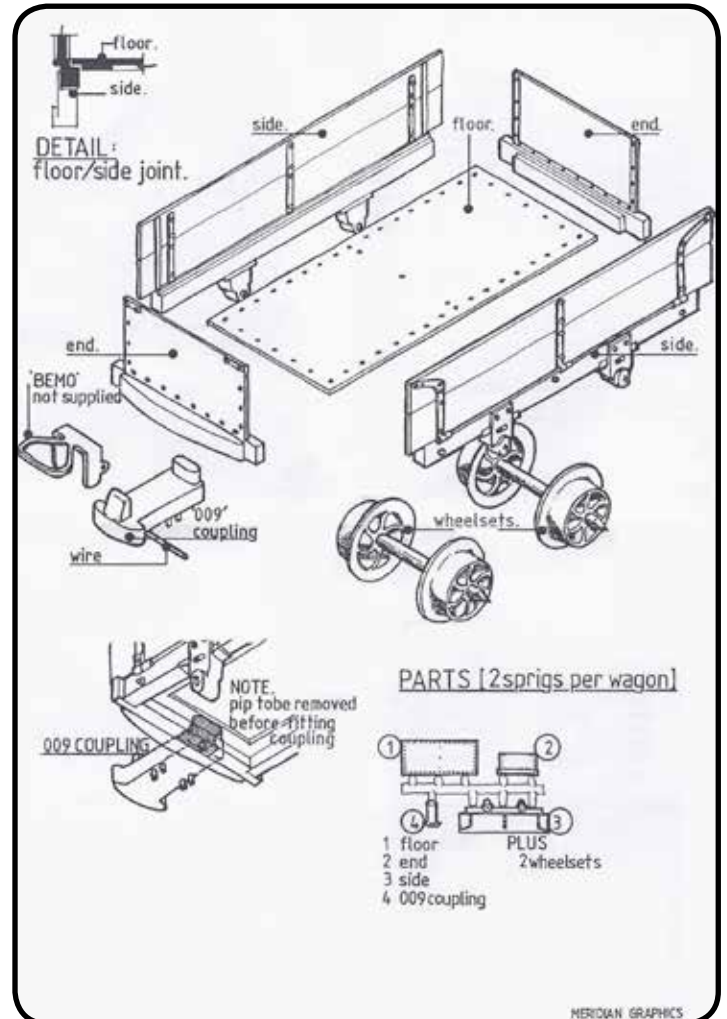

CONTACT DETAILS

www.narrowplanet.co.uk

info@narrowplanet.co.uk

Narrow Planet, PO Box 297,
Bexhill-on-Sea, TN40 9HF

MPM8 • first issue • February 2016