

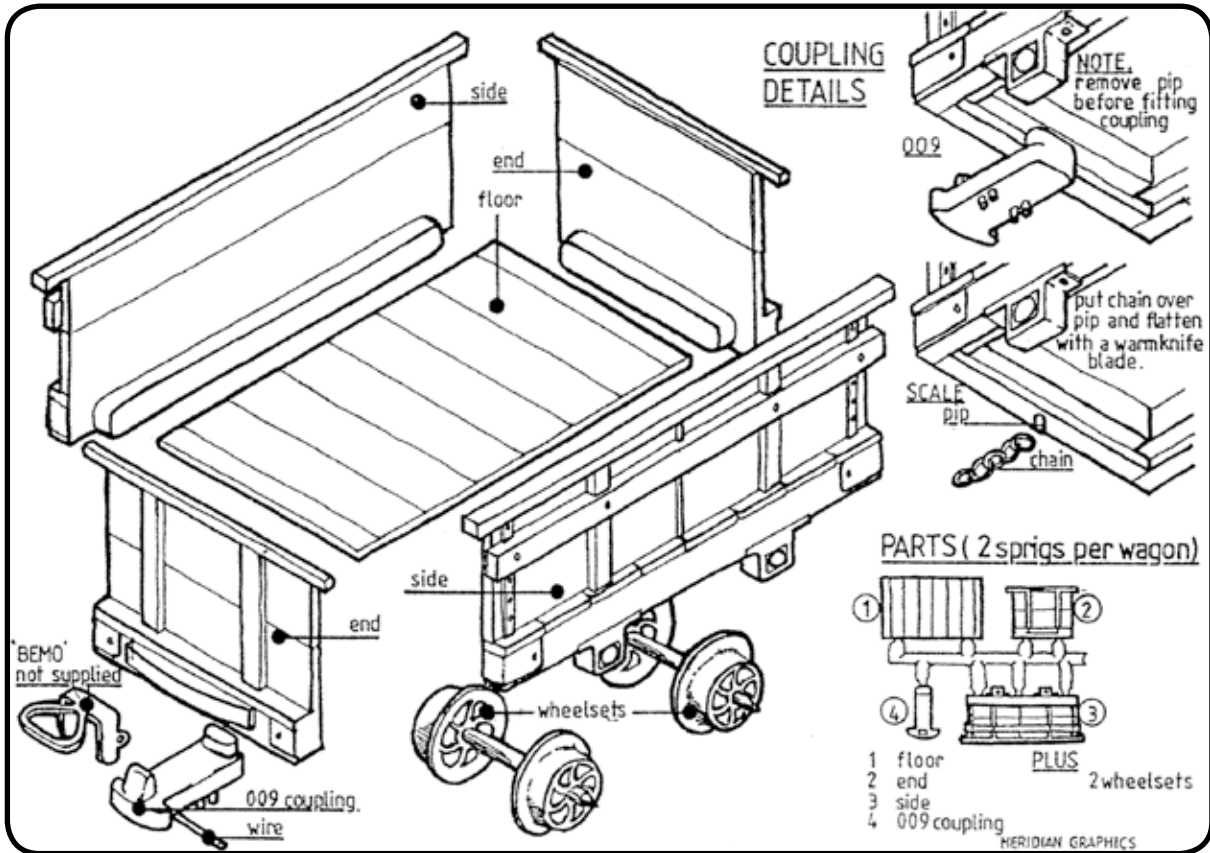

MPM10 • PENRHYN QUARRY RAILWAY WOODEN COAL WAGON (1880)

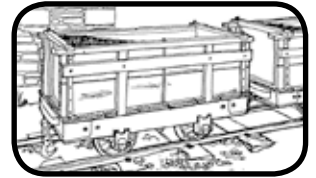

The Penrhyn Quarry Railway (1879 - 1962) carried quarry output from the workings at Bethesda to Porth Penrhyn. Coal was brought by sea to the port and was delivered by rail to the quarry and locations en route for a variety of uses: blacksmiths, pumping engines, domestic and office heating. The first wagons for this traffic were in use when the line was horse drawn, the Penrhyn Railroad (1801 - 1879), a batch built in 1856/7 form the subject of this kit. A feature of this design is the heavy timber 'rubbing strake', these kept open the level crossing gates whilst the train was in motion. The wagons were in use at the end of steam haulage, although other types of coal wagon were built. The last, of all metal, in 1956 with end doors. Examples of the wooden 1856 type have been preserved. No. 1A may be seen in Penrhyn Castle Museum.

BUILDING NOTES

The exploded diagram shows the assembly in detail but the following notes may be useful. Remove parts from the 'sprue' **carefully**, cut, do not break off. Assemble floor to one side and fit one end, dry fit first to check. Ends are inset and butt against to floor, the top rail of the end projects beyond the width and rests on the top of the sides (see header illustration) and is **NOT** flash! Dry fit second side, ensuring squareness in plan and side elevation and, trapping wheelsets in the process, fix in place.

'009' type couplings are supplied **but not** 'Bemo' loops, epoxy resin brass wire to locating pips on under side and trim to suit loop. Fluid cement (Mek Pak) is recommended for assembly of this kit.

PAINTING NOTES

Ex works

Red oxide or light grey • Body, underframe

Black • Axle boxes, ironwork and front face of 'buffing' strakes

Note: The Penrhyn Castle Museum has a black underframe and body interior.

ABOUT MERIDIAN MODELS

Founded in 1973 and driven forward by the late Dave Brewer of the Greenwich & District Narrow Gauge Railway Society (G&DNGRS), with Pete Wilson and other collaborators joining along the way, Meridian Models grew into a well-respected producer of detailed locomotive and rolling stock kits in 009.

Following Pete Wilson's decision to retire in 2015, Narrow Planet has taken on the production and distribution of the plastic rolling stock kits of the Meridian range. If you have any queries about the model or instructions please get in touch.

CONTACT DETAILS

www.narrowplanet.co.uk
info@narrowplanet.co.uk

Narrow Planet, PO Box 297,
Bexhill-on-Sea, TN40 9HF